

Algebra & Number Theory

Volume 17

2023

No. 3



Algebra & Number Theory

msp.org/ant

EDITORS

MANAGING EDITOR

Antoine Chambert-Loir
Université Paris-Diderot
France

EDITORIAL BOARD CHAIR

David Eisenbud
University of California
Berkeley, USA

BOARD OF EDITORS

Jason P. Bell	University of Waterloo, Canada	Philippe Michel	École Polytechnique Fédérale de Lausanne
Bhargav Bhatt	University of Michigan, USA	Martin Olsson	University of California, Berkeley, USA
Frank Calegari	University of Chicago, USA	Irena Peeva	Cornell University, USA
J-L. Colliot-Thélène	CNRS, Université Paris-Saclay, France	Jonathan Pila	University of Oxford, UK
Brian D. Conrad	Stanford University, USA	Anand Pillay	University of Notre Dame, USA
Samit Dasgupta	Duke University, USA	Bjorn Poonen	Massachusetts Institute of Technology, USA
Hélène Esnault	Freie Universität Berlin, Germany	Victor Reiner	University of Minnesota, USA
Gavril Farkas	Humboldt Universität zu Berlin, Germany	Peter Sarnak	Princeton University, USA
Sergey Fomin	University of Michigan, USA	Michael Singer	North Carolina State University, USA
Edward Frenkel	University of California, Berkeley, USA	Vasudevan Srinivas	Tata Inst. of Fund. Research, India
Wee Teck Gan	National University of Singapore	Shunsuke Takagi	University of Tokyo, Japan
Andrew Granville	Université de Montréal, Canada	Pham Huu Tiep	Rutgers University, USA
Ben J. Green	University of Oxford, UK	Ravi Vakil	Stanford University, USA
Christopher Hacon	University of Utah, USA	Akshay Venkatesh	Institute for Advanced Study, USA
Roger Heath-Brown	Oxford University, UK	Melanie Matchett Wood	Harvard University, USA
János Kollár	Princeton University, USA	Shou-Wu Zhang	Princeton University, USA
Michael J. Larsen	Indiana University Bloomington, USA		

PRODUCTION

production@msp.org

Silvio Levy, Scientific Editor

See inside back cover or msp.org/ant for submission instructions.

The subscription price for 2023 is US \$485/year for the electronic version, and \$705/year (+\$65, if shipping outside the US) for print and electronic. Subscriptions, requests for back issues and changes of subscriber address should be sent to MSP.

Algebra & Number Theory (ISSN 1944-7833 electronic, 1937-0652 printed) at Mathematical Sciences Publishers, 798 Evans Hall #3840, c/o University of California, Berkeley, CA 94720-3840 is published continuously online.

ANT peer review and production are managed by EditFLOW[®] from MSP.

PUBLISHED BY

 **mathematical sciences publishers**
nonprofit scientific publishing

<http://msp.org/>

© 2023 Mathematical Sciences Publishers

Quadratic relations between Bessel moments

Javier Fresán, Claude Sabbah and Jeng-Daw Yu

Motivated by the computation of some Feynman amplitudes, Broadhurst and Roberts recently conjectured and checked numerically to high precision a set of remarkable quadratic relations between the Bessel moments

$$\int_0^\infty I_0(t)^i K_0(t)^{k-i} t^{2j-1} dt \quad (i, j = 1, \dots, \lfloor (k-1)/2 \rfloor),$$

where $k \geq 1$ is a fixed integer and I_0 and K_0 denote the modified Bessel functions. We interpret these integrals and variants thereof as coefficients of the period pairing between middle de Rham cohomology and twisted homology of symmetric powers of the Kloosterman connection. Building on the general framework developed by Fresan, Sabbah and Yu (2020), this enables us to prove quadratic relations of the form suggested by Broadhurst and Roberts, which conjecturally comprise all algebraic relations between these numbers. We also make Deligne's conjecture explicit, thus explaining many evaluations of critical values of L -functions of symmetric power moments of Kloosterman sums in terms of determinants of Bessel moments.

1. Introduction	541
2. Pairings on the Kl_2 connection and its moments	545
3. de Rham pairing for $\text{Sym}^k \text{Kl}_2$	552
4. Betti intersection pairing for $\text{Sym}^k \text{Kl}_2$	560
5. Quadratic relations between periods and Bessel moments	565
6. The full period matrices	569
7. Comparison of period structures	575
8. L -functions of Kloosterman sums and Bessel moments	585
Appendix. Period realization of an exponential mixed Hodge structure, by Claude Sabbah	588
Acknowledgments	600
Added in proof	601
References	601

1. Introduction

Let $I_0(t)$ and $K_0(t)$ denote the modified Bessel functions of order zero, which are solutions to the ordinary differential equation $((t\partial_t)^2 - t^2)u = 0$. Since this equation has an irregular singularity at infinity, it does

This research was partly supported by the PICS project TWN 8094 from CNRS. The research of J.F. was also partly supported by the grant ANR-18-CE40-0017 of Agence Nationale de la Recherche.

MSC2020: 32G20, 34M35.

Keywords: Kloosterman connection, period pairing, quadratic relations, Bessel moments.

not come from geometry in the usual sense of encoding how periods vary in a family of algebraic varieties. However, certain integrals of monomials in $I_0(t)$ and $K_0(t)$ called *Bessel moments* are themselves periods, as shown for example by the identity (see [Vanhove 2014, (8.11)])

$$\int_0^\infty I_0(t)K_0(t)^{\ell+1}t \, dt = \frac{1}{2^\ell} \int_{x_i \geq 0} \frac{1}{(1 + \sum_{i=1}^\ell x_i)(1 + \sum_{i=1}^\ell 1/x_i) - 1} \prod_{i=1}^\ell \frac{dx_i}{x_i}.$$

In a series of papers and conference talks Broadhurst and Roberts [Broadhurst 2016; 2017a; 2017b; 2018; Broadhurst and Roberts 2019; Roberts 2017] put forward a program to understand the motivic origin of the Bessel moments

$$\int_0^\infty I_0(t)^a K_0(t)^b t^c \, dt. \tag{1.1}$$

An important insight of theirs was to look at counterparts of these integrals over finite fields, pursuing the analogy between the Bessel differential equation and the Kloosterman ℓ -adic sheaf. Roughly speaking, $I_0(t)$ and $K_0(t)$ correspond to the eigenvalues of Frobenius, and out of them one forms the k -th symmetric power moments of Kloosterman sums. The generating series of these moments over finite extensions of \mathbb{F}_p is a polynomial with integer coefficients. After removing some trivial factors and handling primes of bad reduction, a global L -function $L_k(s)$ is built with the reciprocals of these polynomials as local factors. Back at the beginning, Broadhurst, partly in joint work with Mellit [Broadhurst and Mellit 2016] and Roberts, Bloch, Kerr and Vanhove [Bloch et al. 2015], and Y. Zhou [2018a] proved or numerically checked in many cases that the critical values of these L -functions agree up to rational factors and powers of π with certain determinants of the Bessel moments (1.1).

For technical reasons, we shall make the change of variables $z = t^2/4$ and consider the associated rank-two vector bundle with connection on \mathbb{G}_m , which is called the *Kloosterman connection* and denoted by Kl_2 . Motives associated with symmetric powers of the Kloosterman connection were introduced in [Fresán et al. 2022]. Namely, for each integer $k \geq 1$, we constructed a motive M_k over the rational numbers, which is pure of weight $k + 1$, has rank $k' = \lfloor (k - 1)/2 \rfloor$ (resp. $k' - 1$) if k is not a multiple of 4 (resp. if k is a multiple of 4), and is endowed with a self-duality pairing

$$M_k \otimes M_k \rightarrow \mathbb{Q}(-k - 1) \tag{1.2}$$

that is symplectic if k is even and orthogonal if k is odd. By design, the L -function of this motive coincides with the above L -function $L_k(s)$. The main result of that paper was the computation of the Hodge numbers of M_k , which led to a proof that $L_k(s)$ extends meromorphically to the complex plane and satisfies the expected functional equation.

In this paper, we investigate the period realizations of the motives M_k . By design, the de Rham realization of M_k is isomorphic to the middle de Rham cohomology of the k -th symmetric power $\text{Sym}^k \text{Kl}_2$, which is defined as the image

$$H_{\text{dR,mid}}^1(\mathbb{G}_m, \text{Sym}^k \text{Kl}_2) = \text{im}[H_{\text{dR,c}}^1(\mathbb{G}_m, \text{Sym}^k \text{Kl}_2) \rightarrow H_{\text{dR}}^1(\mathbb{G}_m, \text{Sym}^k \text{Kl}_2)]$$

of compactly supported de Rham cohomology under the natural map to usual de Rham cohomology, and comes with a perfect intersection pairing S_k^{mid} realizing (1.2). Extending a computation from [Fresán et al. 2022, Proposition 4.14], we exhibit a basis of middle de Rham cohomology in Section 3, which is natural in that it is adapted to the Hodge filtration, and we present an explicit formula to compute the matrix of S_k^{mid} on this basis. If k is not a multiple of 4, the basis is simply given by the classes $\omega_i = [z^i v_0^k dz/z]$ for $1 \leq i \leq k'$, where v_0 is a specific section of Kl_2 .

Besides, we shall prove that the dual of the Betti realization of M_k is isomorphic to the middle twisted homology of $\text{Sym}^k \text{Kl}_2$, which is defined as the image

$$H_1^{\text{mid}}(\mathbb{G}_m, \text{Sym}^k \text{Kl}_2) = \text{im}[H_1^{\text{rd}}(\mathbb{G}_m, \text{Sym}^k \text{Kl}_2) \rightarrow H_1^{\text{mod}}(\mathbb{G}_m, \text{Sym}^k \text{Kl}_2)]$$

of rapid decay homology under the natural map to moderate growth homology. Elements of these homology groups are represented by linear combinations of twisted chains $c \otimes e$, where c is a path and e is a horizontal section of $\text{Sym}^k \text{Kl}_2$ that decays rapidly (resp. has moderate growth) on a neighborhood of the support of c . These conditions ensure that de Rham (resp. compactly supported de Rham) cohomology classes can be integrated along them, thus giving rise to a period pairing

$$P_k^{\text{mid}} : H_1^{\text{mid}}(\mathbb{G}_m, \text{Sym}^k \text{Kl}_2) \otimes H_{\text{dR}, \text{mid}}^1(\mathbb{G}_m, \text{Sym}^k \text{Kl}_2) \rightarrow \mathbb{C}.$$

This middle homology comes with a natural \mathbb{Q} -structure and, likewise to middle de Rham cohomology, a perfect intersection pairing B_k^{mid} realizing the transpose of (1.2). By analyzing the asymptotic behaviors of products of modified Bessel functions, we exhibit in Section 4 rapid decay homology classes α_i for $0 \leq i \leq k'$ whose images in middle homology are nonzero for $i \geq 1$.

Relying on the general results from the companion paper [Fresán et al. 2023], in particular the compatibility of the Betti and de Rham intersection pairings with the period pairing, we prove the following theorem. For simplicity, we only state it here when k is not a multiple of 4, postponing the full statements to Proposition 4.6, Theorems 3.17, 4.7, and 5.3, and Corollary 5.7.

Theorem 1.3. *Assume k is not a multiple of 4:*

- (1) *With respect to the basis $\{\omega_i\}_{1 \leq i \leq k'}$, the matrix of the de Rham intersection pairing S_k^{mid} is a lower-right triangular matrix with coefficients in \mathbb{Q} and (i, j) antidiagonal entries*

$$\begin{cases} (-2)^k \frac{k'!}{k!!} & \text{if } k \text{ is odd,} \\ \frac{(-1)^{k'+1}}{2^{k'}(j-i)} \cdot \frac{(k-1)!!}{(k'+1)!} & \text{if } k \text{ is even.} \end{cases}$$

- (2) *The middle homology classes $\{\alpha_i\}_{1 \leq i \leq k'}$ form a basis and the matrix of the Betti intersection pairing B_k^{mid} on this basis is given by*

$$B_k^{\text{mid}} = \left((-1)^{k-i} \frac{(k-i)!(k-j)!}{k!} \frac{\mathcal{B}_{k-i-j+1}}{(k-i-j+1)!} \right)_{1 \leq i, j \leq k'},$$

where \mathcal{B}_n denotes the n -th Bernoulli number.

(3) With respect to the bases $\{\alpha_i\}_{1 \leq i \leq k'}$ and $\{\omega_j\}_{1 \leq j \leq k'}$, the matrix of the period pairing P_k^{mid} consists of the Bessel moments

$$P_k^{\text{mid}} = \left((-1)^{k-i} 2^{k+1-2j} (\pi i)^i \int_0^\infty I_0(t)^i K_0(t)^{k-i} t^{2j-1} dt \right)_{1 \leq i, j \leq k'}$$

(4) The following quadratic relations hold:

$$P_k^{\text{mid}} \cdot (S_k^{\text{mid}})^{-1} \cdot {}^t P_k^{\text{mid}} = (-2\pi i)^{k+1} B_k^{\text{mid}}.$$

Quadratic relations of the shape $P_k^{\text{BR}} \cdot D_k^{\text{BR}} \cdot {}^t P_{k'}^{\text{BR}} = B_k^{\text{BR}}$ were conjectured by Broadhurst and Roberts [2018]. As we explain in Section 5.3, their matrices P_k^{BR} and B_k^{BR} coincide with ours up to different normalizations, but we were unfortunately unable to prove that, again up to normalization, the inverse of S_k^{mid} satisfies the recursive formulas defining their matrix D_k^{BR} . Nevertheless, we checked numerically that both matrices agree for $k \leq 22$, which is the limit for reasonable computation time with Maple.

Grothendieck’s period conjecture predicts that the transcendence degree of the field of periods of M_k agrees with the dimension of its motivic Galois group. Since the Betti intersection pairing is motivic, this is a subgroup of the general orthogonal group $GO_{k'}$ if k is odd and of the general symplectic group $GSp_{k'}$ (resp. $GSp_{k'-1}$) if k is even and not a multiple of 4 (resp. if k is a multiple of 4). Broadhurst and Roberts conjecture that this inclusion is an equality, which would mean that for fixed k the quadratic relations from Theorem 1.3 conjecturally exhaust all algebraic relations between the Bessel moments.

Finally, in Section 8 we make Deligne’s conjecture explicit for the critical values of $L_k(s)$ by identifying the periods that are expected to agree with them up to a rational factor with some determinants of Bessel moments already considered by Broadhurst and Roberts. Prior to that, we identify in Section 7 the period structure of the motive M_k with the period structure attached to the middle cohomology of $\text{Sym}^k \text{Kl}_2$ by means of Theorem 1.3. For that purpose, the appendix develops the necessary tools in a general setting of exponential mixed Hodge structures, complementing thereby the appendix of [Fresán et al. 2022].

Notation 1.4. We refer the reader to [Fresán et al. 2023] for the general setting of de Rham cohomology and twisted homology of vector bundles with connection, as well as the intersection forms and period pairings on these spaces. Throughout this article, we use the following notation and conventions:

- Given an integer $k \geq 1$, we set

$$k' = \lfloor (k - 1/2) \rfloor \quad (\text{i.e., } k = 2k' + 1 \text{ for odd } k \text{ and } k = 2(k' + 1) \text{ for even } k).$$

- Since the case where k is a multiple of 4 plays a special role throughout, we use the simplified common notation

$$\llbracket 1, k' \rrbracket = \begin{cases} \{1, \dots, k'\} & \text{if } 4 \nmid k, \\ \{1, \dots, k'\} \setminus \{k/4\} & \text{if } 4 \mid k, \end{cases}$$

so that

$$\#\llbracket 1, k' \rrbracket = \begin{cases} k' & \text{if } 4 \nmid k, \\ k' - 1 & \text{if } 4 \mid k. \end{cases}$$

We will consider square matrices indexed by $i, j \in \llbracket 1, k' \rrbracket$ that, when k is a multiple of 4, are obtained from a $k' \times k'$ matrix by deleting the row and column of index $k/4$.

- For integers $m \leq 0$, the factorial $m!$ and double factorial $m!!$ are given the value 1.
- For each integer $n \geq 0$, we denote by \mathcal{B}_n the n -th Bernoulli number, i.e., the n -th coefficient of the power series expansion

$$\frac{x}{e^x - 1} = \sum_{n=0}^{\infty} \mathcal{B}_n \frac{x^n}{n!}.$$

- The base torus is denoted by $\mathbb{G}_{m,z}$, and is regarded as included in the affine line with coordinate z . The coordinate $1/z$ is denoted by w . We also consider the degree two morphism $\rho_2 : \mathbb{G}_{m,t} \rightarrow \mathbb{G}_{m,z}$ which, at the ring level, is defined by $z \mapsto t^2/4$.

2. Pairings on the Kl_2 connection and its moments

In this section, we explain the algebraic duality pairing on $\text{Sym}^k \text{Kl}_2$ that gives rise to the de Rham intersection pairing. On the other hand, we endow the associated local system of flat sections $\text{Sym}^k \text{Kl}_2^\nabla$ with a \mathbb{Q} -structure and a topological duality pairing that will give rise to the Betti intersection pairing.

2.1. The Kl_2 connection. We first recall the definition of the Kl_2 connection, referring the reader to [Fresán et al. 2022, Section 4.1] for more details. We denote by $\mathbb{G}_{m,x}$ (resp. $\mathbb{G}_{m,z}$) the torus \mathbb{G}_m over the complex numbers with coordinate x (resp. z), and we define $f : \mathbb{G}_{m,x} \times \mathbb{G}_{m,z} \rightarrow \mathbb{A}^1$ as $f(x, z) = x + z/x$.

Let $\pi : \mathbb{G}_{m,x} \times \mathbb{G}_{m,z} \rightarrow \mathbb{G}_{m,z}$ denote the projection to the second factor and E^f the rank-one vector bundle with connection $(\mathcal{O}_{\mathbb{G}_{m,x} \times \mathbb{G}_{m,z}}, d + df)$ on $\mathbb{G}_{m,x} \times \mathbb{G}_{m,z}$. We define Kl_2 as the pushforward (in the sense of \mathcal{D} -modules) $\mathcal{H}^1 \pi_+ E^f$: this is a free $\mathcal{O}_{\mathbb{G}_m}$ -module of finite rank endowed with a connection having a regular singularity at the origin and an irregular one at infinity. Since the varieties we work with are all affine, it will be convenient to identify coherent sheaves with their global sections. To the sheaf $\mathcal{H}^1 \pi_+ E^f$ is then associated the module $H^1 \pi_+ E^f$ of global sections. Fixing the generator dx/x of relative differentials and denoting by ∂_x the partial derivative with respect to the variable x , we then have

$$\text{Kl}_2 = H^1 \pi_+ E^f = \text{coker}[\mathbb{C}[x, x^{-1}, z, z^{-1}] \xrightarrow{x\partial_x + (x-z/x)} \mathbb{C}[x, x^{-1}, z, z^{-1}]].$$

It follows that Kl_2 is the free $\mathbb{C}[z, z^{-1}]$ -module generated by the class v_0 of dx/x and the class v_1 of dx . The connection ∇ on Kl_2 satisfies

$$z\nabla_{\partial_z}(v_0, v_1) = (v_0, v_1) \cdot \begin{pmatrix} 0 & z \\ 1 & 0 \end{pmatrix},$$

so that v_0 is a solution to the differential equation $((z\partial_z)^2 - z)v = 0$.

Let $j : \mathbb{G}_{m,x} \hookrightarrow \mathbb{P}^1$ denote the inclusion. We write j_+^\dagger for the adjoint by duality of the pushforward j_+ , and similarly for π . The same argument as in [Malgrange 1991, Appendix 2, Proposition (1.7) page 217]

shows that the natural map $(j \times \text{Id})_{\dagger} E^f \rightarrow (j \times \text{Id})_{+} E^f$ is an isomorphism. Projecting to $\mathbb{G}_{m,z}$, we deduce that

$$H^1 \pi_{\dagger} E^f \rightarrow H^1 \pi_{+} E^f \tag{2.1}$$

is an isomorphism as well. Let us make this explicit. We set $x' = 1/x$. By an argument similar to that of [Fresán et al. 2023, Corollary 3.5], we can represent an element of $H^1 \pi_{\dagger} E^f$ as a pair $(\widehat{\psi}, \eta dx/x) = (\widehat{\psi}, -\eta dx'/x')$, where

- $\eta \in \mathbb{C}[x, x^{-1}, z, z^{-1}]$,
- $\widehat{\psi} = (\widehat{\psi}_0, \widehat{\psi}_{\infty})$, with

$$\widehat{\psi}_0 \in \mathbb{C}[z, z^{-1}][[x]][x^{-1}] \quad \text{and} \quad \widehat{\psi}_{\infty} \in \mathbb{C}[z, z^{-1}][[x']][x'^{-1}],$$

are such that the following holds:

$$(x \partial_x + (x - z/x)) \widehat{\psi}_0 = \iota_{\widehat{0}} \eta, \quad (x' \partial_{x'} + (zx' - 1/x')) \widehat{\psi}_{\infty} = -\iota_{\infty} \eta. \tag{2.2}$$

Here, $\iota_{\widehat{0}} : \mathbb{C}[x, x^{-1}, z, z^{-1}] \hookrightarrow \mathbb{C}[z, z^{-1}][[x]][x^{-1}]$ denotes the natural inclusion, and similarly for ι_{∞} . On these representatives, the natural morphism (2.1) is given by $(\widehat{\psi}, \eta dx/x) \mapsto \eta dx/x$. Checking that (2.1) is an isomorphism amounts to checking that, for any η as above, there exists a unique $\widehat{\psi}$ such that the (2.2) hold. Setting $\widehat{\psi}_0 = \sum_{n \geq n_0} \psi_{0,n}(z)x^n$ and $\widehat{\psi}_{\infty} = \sum_{n \geq n_{\infty}} \psi_{\infty,n}(z)x'^n$, $\iota_{\widehat{0}} \eta = \sum_n \eta_{0,n} x^n$, $\iota_{\infty} \eta = \sum_n \eta_{\infty,n} x'^n$, we determine $\psi_{0,n}(z)$ and $\psi_{\infty,n}(z)$ inductively by

$$\psi_{0,n+1} = z^{-1}(k\psi_{0,n} + \psi_{0,n-1} - \eta_{0,n}), \quad \psi_{\infty,n+1} = n\psi_{\infty,n} + z\psi_{\infty,n-1} + \eta_{\infty,n}, \tag{2.3}$$

thus showing explicitly that (2.1) is an isomorphism.

Example 2.4. The element of $H^1 \pi_{\dagger} E^f$ corresponding to v_0 (resp. v_1) is $(\widehat{\varphi}, dx/x)$ (resp. $(\widehat{\psi}, dx)$), where the elements $\widehat{\varphi}$ and $\widehat{\psi}$ determined by (2.3) satisfy (note that $\eta = 1$ resp. $\eta = x = 1/x'$)

$$\begin{cases} \varphi_{0, \leq 0} = 0, \\ \varphi_{0,1} = -z^{-1}, \\ \varphi_{\infty, \leq 0} = 0, \\ \varphi_{\infty,1} = 1, \end{cases} \quad \begin{cases} \psi_{0, \leq 1} = 0, \\ \psi_{\infty, < 0} = 0, \\ \psi_{\infty,0} = 1, \\ \psi_{\infty,1} = 0. \end{cases}$$

2.2. Algebraic duality on Kl_2 and its moments. Set

$$D = \{0, \infty\} = \mathbb{P}^1 \setminus \mathbb{G}_m.$$

Starting from the tautological pairing $E^f \otimes E^{-f} \rightarrow (\mathcal{O}_{\mathbb{G}_{m,x} \times \mathbb{G}_{m,z}}, d)$, we deduce a natural pairing

$$\langle \cdot, \cdot \rangle : H^1 \pi_{\dagger} E^f \otimes H^1 \pi_{+} E^{-f} \rightarrow H^2 \pi_{\dagger} \mathcal{O}_{\mathbb{G}_{m,x} \times \mathbb{G}_{m,z}} \xrightarrow{\text{res}_D} \mathbb{C}[z^{\pm 1}],$$

where the isomorphism res_D stands for the residue along D as in [Fresán et al. 2023, Section 3.c] (see also the proof of Lemma 2.5 below). Let $\iota : \mathbb{G}_{m,x} \times \mathbb{G}_{m,z} \rightarrow \mathbb{G}_{m,x} \times \mathbb{G}_{m,z}$ denote the involution $(x, z) \mapsto (-x, z)$.

Then $\iota^+ E^{-f} = E^f$, and this defines a canonical isomorphism $\mu : H^1 \pi_+ E^f \xrightarrow{\sim} H^1 \pi_+ E^{-f}$ since $\pi \circ \iota = \pi$. Let us set

$$(v_0^-, v_1^-) = \iota^*(v_0, v_1) = (dx/x, -dx),$$

that we consider as a basis of $H^1 \pi_+ E^{-f}$. Then the matrix of $z\nabla_{\partial_z}$ on $H^1 \pi_+ E^{-f}$ is equal to $\begin{pmatrix} 0 & z \\ 1 & 0 \end{pmatrix}$, and the above isomorphism reads $\mu(v_0, v_1) = (v_0^-, v_1^-)$.

Lemma 2.5. *The induced pairing*

$$\langle \cdot, \cdot \rangle_{\text{alg}} : H^1 \pi_+ E^f \otimes H^1 \pi_+ E^f \rightarrow \mathbb{C}[z^{\pm 1}]$$

defined by $\langle \cdot, \cdot \rangle_{\text{alg}} = \langle (2.1)^{-1} \cdot, \mu \cdot \rangle$ satisfies

$$\langle v_0, v_0 \rangle_{\text{alg}} = \langle v_1, v_1 \rangle_{\text{alg}} = 0, \quad \langle v_0, v_1 \rangle_{\text{alg}} = -\langle v_1, v_0 \rangle_{\text{alg}} = 1.$$

In other words, we get a skew-symmetric perfect pairing on Kl_2 :

$$\langle \cdot, \cdot \rangle_{\text{alg}} : (\text{Kl}_2, \nabla) \otimes (\text{Kl}_2, \nabla) \rightarrow (\mathcal{O}_{\mathbb{G}_m}, \mathfrak{d}), \tag{2.6}$$

which amounts to a canonical isomorphism $\lambda_{\text{alg}} : \text{Kl}_2 \rightarrow \text{Kl}_2^\vee$ with the dual connection endowed with the dual basis (v_0^\vee, v_1^\vee) , by setting

$$\begin{aligned} & \text{Kl}_2 \xrightarrow{\lambda_{\text{alg}}} \text{Kl}_2^\vee \\ (v_0, v_1) & \longmapsto (-v_1^\vee, v_0^\vee). \end{aligned}$$

Proof. We compute with the notation of [Example 2.4](#). We find, on the one hand,

$$\begin{aligned} \langle v_0, v_0 \rangle_{\text{alg}} &= \langle (\widehat{\varphi}, v_0), v_0^- \rangle = \text{res}_D \widehat{\varphi} \frac{dx}{x} = \varphi_{0,0} - \varphi_{\infty,0} = 0, \\ \langle v_1, v_1 \rangle_{\text{alg}} &= \langle (\widehat{\psi}, v_1), v_1^- \rangle = -\text{res}_D \widehat{\psi} dx = -\psi_{0,-1} + \psi_{\infty,1} = 0, \end{aligned}$$

and, on the other hand,

$$\begin{aligned} \langle v_0, v_1 \rangle_{\text{alg}} &= \langle (\widehat{\varphi}, v_0), v_1^- \rangle = -\text{res}_D \widehat{\varphi} dx = -\varphi_{0,-1} + \varphi_{\infty,1} = 1, \\ \langle v_1, v_0 \rangle_{\text{alg}} &= \langle (\widehat{\psi}, v_1), v_0^- \rangle = \text{res}_D \widehat{\psi} \frac{dx}{x} = \psi_{0,0} - \psi_{\infty,0} = -1. \end{aligned} \quad \square$$

For each $k \geq 1$, let \mathfrak{S}_k be the symmetric group acting on the tensor power $\text{Kl}_2^{\otimes k}$ by the natural permutation action. Let $\text{Sym}^k \text{Kl}_2$ be the symmetric power regarded as the \mathfrak{S}_k -invariant part of $\text{Kl}_2^{\otimes k}$. We consider the basis $\mathbf{u} = (u_a)_{0 \leq a \leq k}$ of $\text{Sym}^k \text{Kl}_2$ given by

$$u_a = v_0^{k-a} v_1^a = \frac{1}{|\mathfrak{S}_k|} \sum_{\sigma \in \mathfrak{S}_k} \sigma(v_0^{\otimes k-a} \otimes v_1^{\otimes a}),$$

in which the connection reads

$$z\partial_z u_a = (k-a)u_{a+1} + azu_{a-1} \quad (0 \leq a \leq k)$$

with the convention $u_{k+1} = 0$. The pairing (2.6) extends to $\text{Sym}^k \text{Kl}_2$, which is thus endowed with the following $(-1)^k$ -symmetric pairing (compatible with the connection):

$$\langle u_a, u_b \rangle_{\text{alg}} = \begin{cases} (-1)^a \frac{a!b!}{k!} & \text{if } a + b = k, \\ 0 & \text{otherwise.} \end{cases} \tag{2.7}$$

2.3. The \mathbb{Q} -structure of Kl_2^\vee and its moments.

The \mathbb{Q} -structure for a fixed nonzero z . We start by considering the \mathbb{Q} -structure on the fiber of the sheaf of analytic flat sections Kl_2^\vee at some $z \in \mathbb{G}_{m,z}$. We consider the function $f_z : \mathbb{G}_{m,x} \rightarrow \mathbb{A}^1$, defined as $f_z(x) = x + z/x$, where z is a fixed nonzero complex number, and $E^{f_z} = (\mathcal{O}_{\mathbb{G}_{m,x}}, d + df_z)$. Let \mathbb{P}_x^1 be the projective closure of $\mathbb{G}_{m,x}$ and let $\tilde{\mathbb{P}}^1$ be the real oriented blow-up along $D = \{0, \infty\}$, which is topologically a closed annulus. We denote by $\tilde{j} : \mathbb{G}_{m,x}^{\text{an}} \hookrightarrow \tilde{\mathbb{P}}^1$ the inclusion of the open annulus into the closed one. On $\tilde{\mathbb{P}}^1$, the de Rham complexes with rapid decay $\text{DR}^{\text{rd}}(E^{f_z})$ and with moderate growth $\text{DR}^{\text{mod}}(E^{f_z})$ have cohomology in degree zero only (see [Fresán et al. 2023, Theorem 2.30]), and the natural morphism $\text{DR}^{\text{rd}}(E^{f_z}) \rightarrow \text{DR}^{\text{mod}}(E^{f_z})$ is a quasiisomorphism. Indeed, the function e^{-f_z} on $\mathbb{G}_{m,x}^{\text{an}}$ has moderate growth near a point of the boundary $\partial\tilde{\mathbb{P}}^1$ if and only if it has rapid decay there. Above $x = 0$, this amounts to $\arg x \in \arg z + (-\pi/2, \pi/2) \bmod 2\pi$. Above $x = \infty$, this amounts to $\arg x \in (-\pi/2, \pi/2) \bmod 2\pi$. We denote by $\tilde{\mathbb{P}}_{\text{rd}}^1$ the open set which is the union of $\mathbb{G}_{m,x}^{\text{an}}$ and these two boundary open intervals, so that we have natural open inclusions

$$\mathbb{G}_{m,x}^{\text{an}} \xrightarrow{a_z} \tilde{\mathbb{P}}_{\text{rd}}^1 \xrightarrow{b_z} \tilde{\mathbb{P}}^1.$$

Then multiplication by e^{-f_z} yields an isomorphism of sheaves of \mathbb{C} -vector spaces

$$b_{z,!} a_{z,*} \mathbb{C}_{\mathbb{G}_{m,x}^{\text{an}}} \xrightarrow{\sim} \mathcal{H}^0 \text{DR}^{\text{rd}}(E^{f_z}) = \mathcal{H}^0 \text{DR}^{\text{mod}}(E^{f_z}). \tag{2.8}$$

Definition 2.9. The \mathbb{Q} -subsheaf $\mathcal{H}^0 \text{DR}^{\text{rd}}(E^{f_z})_{\mathbb{Q}} \subset \mathcal{H}^0 \text{DR}^{\text{rd}}(E^{f_z})$ is the image of $b_{z,!} a_{z,*} \mathbb{Q}_{\mathbb{G}_{m,x}^{\text{an}}}$ under the above isomorphism.

The Betti \mathbb{Q} -structure on $H_{\text{dR}}^1(\mathbb{G}_{m,x}, E^{f_z})$ (see [Fresán et al. 2023, Section 2.d]) is defined by means of (2.8) as

$$H_{\text{dR}}^1(\mathbb{G}_{m,x}, E^{f_z})_{\mathbb{Q}} = H^1(\tilde{\mathbb{P}}^1, b_{z,!} a_{z,*} \mathbb{Q}_{\mathbb{G}_{m,x}^{\text{an}}}) = H_c^1(\tilde{\mathbb{P}}_{\text{rd}}^1, a_{z,*} \mathbb{Q}_{\mathbb{G}_{m,x}^{\text{an}}}).$$

We denote by (recall that $z \neq 0$ is fixed):

- c_0^x the unit circle in $\mathbb{G}_{m,x}^{\text{an}}$ starting at 1 and oriented counterclockwise.
- c_z^x a smooth oriented path in $\mathbb{G}_{m,x}^{\text{an}}$ starting in a direction $\arg x$ contained in $\arg z + (-\pi/2, \pi/2) \bmod 2\pi$ at $x = 0$, intersecting c_0^x transversally only once, so that the local intersection number (Kronecker index) (c_z^x, c_0^x) is equal to one, and abutting to $x = \infty$ in a direction of $\arg x$ contained in $(-\pi/2, \pi/2) \bmod 2\pi$. The precise choice of c_z^x will be made later. We also consider the path c_z^{-x} obtained from c_z^x by applying the involution $\iota : x \mapsto -x$.

These paths define twisted cycles $\alpha_z^x = -c_z^x \otimes e^{-fz}$ and $\beta_z^x = c_0^x \otimes e^{-fz}$ in rapid decay homology $H_1^{\text{rd}}(\mathbb{G}_{m,x}, E^{fz})$ (see e.g., [Fresán et al. 2023, Section 2.d]). Similarly, we set

$$(\alpha_z^x)^\vee = -c_z^{-x} \otimes e^{fz} \quad \text{and} \quad (\beta_z^x)^\vee = -c_0^x \otimes e^{fz},$$

which define twisted cycles in $H_1^{\text{rd}}(\mathbb{G}_{m,x}, E^{-fz})$. As for the de Rham cohomology, the involution ι induces an isomorphism $H_1^{\text{rd}}(\mathbb{G}_{m,x}, E^{fz}) \rightarrow H_1^{\text{rd}}(\mathbb{G}_{m,x}, E^{-fz})$ sending a rapid decay chain $s \mapsto a(s) \otimes e^{-fz}$ to the rapid decay chain $s \mapsto -a(s) \otimes e^{fz}$, and thus inducing the corresponding Betti intersection pairing

$$H_1^{\text{rd}}(\mathbb{G}_{m,x}, E^{fz}) \otimes H_1^{\text{rd}}(\mathbb{G}_{m,x}, E^{fz}) \xrightarrow{\sim} H_1^{\text{rd}}(\mathbb{G}_{m,x}, E^{fz}) \otimes H_1^{\text{rd}}(\mathbb{G}_{m,x}, E^{-fz}) \rightarrow H_0(\mathbb{G}_{m,x}, \mathbb{C}) = \mathbb{C}.$$

This pairing is easily computed and has matrix $\begin{pmatrix} 0 & 1 \\ 1 & 0 \end{pmatrix}$, thus showing that (α_z^x, β_z^x) is a \mathbb{Q} -basis of $H_1^{\text{rd}}(\mathbb{G}_{m,x}, E^{fz})_{\mathbb{Q}}$.

For applying [Fresán et al. 2023, Proposition 2.23], we use the topological duality pairing $\langle \cdot, \cdot \rangle_{\text{top}}$ on $H_1^{\text{rd}}(\mathbb{G}_{m,x}, E^{fz})$, which preserves the \mathbb{Q} -structure since it is induced by Poincaré–Verdier duality. The following relation holds; see [loc. cit., (3.10)]:

$$\langle \cdot, \cdot \rangle_{\text{top}} = 2\pi i \langle \cdot, \cdot \rangle_{\text{alg}}.$$

We let $(v_i^{\vee, \text{top}} = \frac{1}{2\pi i} v_i^\vee)$ denote the dual basis of (v_i) with respect to $\langle \cdot, \cdot \rangle_{\text{top}}$.

Proposition 2.10. *The \mathbb{Q} -vector space $H_{\text{dR}}^1(\mathbb{G}_{m,x}, E^{fz})_{\mathbb{Q}}$ is the \mathbb{Q} -span of*

$$\begin{aligned} e_0 &= \left(\frac{1}{2\pi i} \int_{c_0^x} e^{-fz} dx \right) \cdot v_0 - \left(\frac{1}{2\pi i} \int_{c_0^x} e^{-fz} \frac{dx}{x} \right) \cdot v_1 \quad \text{and} \\ e_1 &= -\left(\frac{1}{2\pi i} \int_{c_z^x} e^{-fz} dx \right) \cdot v_0 + \left(\frac{1}{2\pi i} \int_{c_z^x} e^{-fz} \frac{dx}{x} \right) \cdot v_1. \end{aligned}$$

Proof. From [loc. cit., Proposition 2.23], we deduce that $H_{\text{dR}}^1(\mathbb{G}_{m,x}, E^{fz})_{\mathbb{Q}}$ is the \mathbb{Q} -span of

$$P_1^{\text{rd, mod}}(\beta_z^x, v_0^{\vee, \text{top}})v_0 + P_1^{\text{rd, mod}}(\beta_z^x, v_1^{\vee, \text{top}})v_1 \quad \text{and} \quad P_1^{\text{rd, mod}}(\alpha_z^x, v_0^{\vee, \text{top}})v_0 + P_1^{\text{rd, mod}}(\alpha_z^x, v_1^{\vee, \text{top}})v_1, \quad (2.11)$$

where $P_1^{\text{rd, mod}} : H_1^{\text{rd}}(\mathbb{G}_{m,x}, E^{fz}) \otimes H_{\text{dR}}^1(\mathbb{G}_{m,x}, E^{fz}) \rightarrow \mathbb{C}$ denotes the period pairing from [loc. cit., Section 2.d]. We conclude with the identification

$$v_0^{\vee, \text{top}} = \frac{1}{2\pi i} v_1 = \frac{1}{2\pi i} [dx] \quad \text{and} \quad v_1^{\vee, \text{top}} = -\frac{1}{2\pi i} v_0 = -\frac{1}{2\pi i} [dx/x].$$

For example, the integral $\frac{1}{2\pi i} \int_{c_0^x} e^{-fz} dx$ is identified with the period

$$P_1^{\text{rd, mod}}(\beta_z^x, v_0^{\vee, \text{top}}).$$

□

The \mathbb{Q} -structure on Kl_2^∇ . We first recall some basic properties of the modified Bessel functions of order zero

$$\begin{aligned} I_0(t) &= \frac{1}{2\pi i} \oint \exp\left(-\frac{t}{2}\left(y + \frac{1}{y}\right)\right) \frac{dy}{y}, \\ K_0(t) &= \frac{1}{2} \int_0^\infty \exp\left(-\frac{t}{2}\left(y + \frac{1}{y}\right)\right) \frac{dy}{y} \quad (|\arg t| < \pi/2), \end{aligned} \tag{2.12}$$

which are annihilated by the modified Bessel operator $(t\partial_t)^2 - t^2$. The function $I_0(t)$ is entire and satisfies $I_0(t) = I_0(-t)$. The function $K_0(t)$ extends analytically to a multivalued function on \mathbb{C}^\times satisfying the rule $K_0(e^{\pi i}t) = K_0(t) - \pi i I_0(t)$.

We have the following estimates as $t \rightarrow 0$ in any bounded ramified sector, by taking the real determination of $\log(t/2)$ when $t \in \mathbb{R}_{>0}$

$$I_0(t) = 1 + O(t^2), \quad K_0(t) = -(\gamma + \log(t/2)) + O(t^2 \log t),$$

where $\gamma = 0.5772\dots$ is the Euler constant. As a consequence, in such sectors,

$$I_0(t)^i K_0(t)^{k-i} = (-1)^{k-i} (\gamma + \log(t/2))^{k-i} + O(t^2 \log^{k-i} t). \tag{2.13}$$

On the other hand, we have the asymptotic expansions at infinity (see [Watson 1944, Section 7.23])

$$\begin{aligned} I_0(t) &\sim e^t \frac{1}{\sqrt{2\pi t}} \sum_{n=0}^\infty \frac{((2n-1)!!)^2}{2^{3n} n!} \frac{1}{t^n}, \quad |\arg t| < \pi/2 \\ K_0(t) &\sim e^{-t} \sqrt{\frac{\pi}{2t}} \sum_{n=0}^\infty (-1)^n \frac{((2n-1)!!)^2}{2^{3n} n!} \frac{1}{t^n}, \quad |\arg t| < 3\pi/2 \\ I_0(t)K_0(t) &\sim \frac{1}{2t} \sum_{n=0}^\infty \frac{((2n-1)!!)^3}{2^{3n} n!} \frac{1}{t^{2n}}. \end{aligned} \tag{2.14}$$

The latter is the unique formal solution in $1/t$ of the second symmetric power $(t\partial_t)^3 - 4t^2(t\partial_t) - 4t^2$ of the modified Bessel operator up to a scalar. Let us also note that these asymptotic expansions can be differentiated termwise. The Wronskian is given by $I_0(t)K_0'(t) - I_0'(t)K_0(t) = -1/t$.

We now assume that z varies in $\mathbb{C} \setminus \mathbb{R}_{\leq 0}$ and we choose a square root $t/2$ of z satisfying $\text{Re}(t) > 0$, that is, $\arg t \in (-\pi/2, \pi/2) \bmod 2\pi$. Due to formulas (2.11), since the integration paths can be made to vary in a locally constant way, we conclude that e_0, e_1 are sections of Kl_2^∇ on this domain, and their coefficients on the basis v_0, v_1 are holomorphic there. We will express them in terms of the modified Bessel functions. We set $x = (t/2)y$. On the one hand, we have

$$\frac{1}{2\pi i} \int_{c_0^x} e^{-f_z} \frac{dx}{x} = \frac{1}{2\pi i} \int_{(t/2)c_0^y} \exp\left(-\frac{t}{2}\left(y + \frac{1}{y}\right)\right) \frac{dy}{y} = \frac{1}{2\pi i} \int_{c_0^y} \exp\left(-\frac{t}{2}\left(y + \frac{1}{y}\right)\right) \frac{dy}{y} = I_0(t).$$

On the other hand, we now regard y as varying in $\mathbb{R}_{>0}$ and set $c_z^x = (t/2)\mathbb{R}_{>0}$, so that, for $x \in c_z^x$, both $\arg(z/x)$ and $\arg(x)$ belong to $(-\pi/2, \pi/2) \bmod 2\pi$. Then, similarly,

$$\frac{1}{2\pi i} \int_{c_z^x} e^{-f_z} \frac{dx}{x} = \frac{1}{2\pi i} \int_{\mathbb{R}_{>0}} \exp\left(-\frac{t}{2}\left(y + \frac{1}{y}\right)\right) \frac{dy}{y} = \frac{1}{\pi i} K_0(t).$$

By flatness of e_0, e_1 , we obtain therefore

$$e_0 = (t/2)I_0'(t)v_0 - I_0(t)v_1 \quad \text{and} \quad e_1 = \frac{1}{\pi i}(-t/2)K_0'(t)v_0 + K_0(t)v_1. \tag{2.15}$$

The pairing $\langle \cdot, \cdot \rangle_{\text{top}} = 2\pi i \langle \cdot, \cdot \rangle_{\text{alg}}$ being flat, it induces a nondegenerate pairing on the constant sheaf $\text{Kl}_2^\vee|_{\mathbb{C} \setminus \mathbb{R}_{\leq 0}}$ and we have there

$$\langle e_0, e_1 \rangle_{\text{top}} = 2\pi i \left((t/2)I_0'(t) \cdot \frac{1}{\pi i} K_0(t) - I_0(t) \cdot (t/2) \frac{1}{\pi i} K_0'(t) \right) = t(I_0'(t)K_0(t) - I_0(t)K_0'(t)) = 1,$$

according to the Wronskian relation. The other pairings are deduced from this one by skew-symmetry. We also obtain

$$v_0 = (2K_0(t)e_0 + 2\pi i I_0(t)e_1), \quad v_1 = t(K_0'(t)e_0 + \pi i I_0'(t)e_1). \tag{2.16}$$

In order to cross the cut $z \in \mathbb{R}_{<0}$, we note that the coefficients of e_0 , regarded as functions of $z \in \mathbb{C}$, are entire, while those of e_1 are multivalued holomorphic, and the monodromy operator T defined by analytic continuation along the path $\theta \mapsto e^\theta z$ ($\theta \in [0, 2\pi i]$) acts on e_1 as $T(e_1) = e_1 + e_0$. This shows that the \mathbb{Q} -structure of $\text{Kl}_2^\vee|_{\mathbb{C} \setminus \mathbb{R}_{\leq 0}}$ extends to a \mathbb{Q} -structure of Kl_2^\vee , which will be denoted by $(\text{Kl}_2^\vee)_{\mathbb{Q}}$. Moreover,

$$\langle \cdot, \cdot \rangle_{\text{top}} : (\text{Kl}_2^\vee)_{\mathbb{Q}} \otimes (\text{Kl}_2^\vee)_{\mathbb{Q}} \rightarrow \mathbb{Q}$$

is a nondegenerate skew-symmetric pairing, and the multivalued flat sections e_0 and e_1 satisfy $\langle e_0, e_1 \rangle_{\text{top}} = 1$.

The \mathbb{Q} -structure on $\text{Sym}^k \text{Kl}_2$. We naturally endow $\text{Sym}^k \text{Kl}_2$ with the pairing

$$\langle \cdot, \cdot \rangle_{\text{top}} = (2\pi i)^k \langle \cdot, \cdot \rangle_{\text{alg}}$$

and the \mathbb{Q} -structure $(\text{Sym}^k \text{Kl}_2)_{\mathbb{Q}}^\vee = \text{Sym}^k((\text{Kl}_2^\vee)_{\mathbb{Q}})$. The monomial sections

$$e_0^{k-a} e_1^a = \frac{1}{|\mathfrak{S}_k|} \sum_{\sigma \in \mathfrak{S}_k} \sigma(e_0^{\otimes k-a} \otimes e_1^{\otimes a}) \quad (0 \leq a \leq k) \tag{2.17}$$

form a basis of multivalued flat sections of the subsheaf $(\text{Sym}^k \text{Kl}_2)_{\mathbb{Q}}^\vee$ of $(\text{Kl}_2^{\otimes k})_{\mathbb{Q}}^\vee$ and satisfy

$$\langle e_0^{k-a} e_1^a, e_0^{k-b} e_1^b \rangle_{\text{top}} = \begin{cases} (-1)^a \frac{a!b!}{k!} & \text{if } a + b = k, \\ 0 & \text{otherwise.} \end{cases} \tag{2.18}$$

Lemma 2.19. *The coefficients of the flat sections $e_0^{k-a} e_1^a$ on the meromorphic basis $(u_b)_b$ of $\text{Sym}^k \text{Kl}_2$ have moderate growth at the origin. Moreover, they have moderate growth (resp. rapid decay) in a small sector centered at infinity and containing $\mathbb{R}_{>0}$ if and only if $a \leq k/2$ (resp. $a < k/2$).*

Proof. Since $I'_0(t)$ (resp. $K'_0(t)$) has an asymptotic expansion similar to that of $I_0(t)$ (resp. $K_0(t)$) at the origin and at infinity in the specified domains, the first statement follows from (2.15) and the definition (2.12) of I_0 and K_0 . Besides, the asymptotic expansion of I_0 and K_0 at infinity (2.14) implies the second statement by calculating the power of e^t in the products of I_0 and K_0 . □

3. de Rham pairing for $\text{Sym}^k \text{Kl}_2$

The main result of this section is the computation of the matrices of the de Rham pairings

$$\begin{aligned} & H_{\text{dR},c}^1(\mathbb{G}_m, \text{Sym}^k \text{Kl}_2) \otimes H_{\text{dR}}^1(\mathbb{G}_m, \text{Sym}^k \text{Kl}_2) \xrightarrow{S} \mathbb{C} \\ & H_{\text{dR},\text{mid}}^1(\mathbb{G}_m, \text{Sym}^k \text{Kl}_2) \otimes H_{\text{dR},\text{mid}}^1(\mathbb{G}_m, \text{Sym}^k \text{Kl}_2) \xrightarrow{S_{\text{mid}}} \mathbb{C} \end{aligned} \tag{3.1}$$

with respect to suitable bases, taking into account the self-duality pairing induced by (2.7). Since the latter is $(-1)^k$ -symmetric, (3.1) is $(-1)^{k+1}$ -symmetric. We first make clear the bases in which we compute the matrices.

3.1. Bases of the de Rham cohomology. Let

$$\iota_{\widehat{0}} : \text{Sym}^k \text{Kl}_2 \rightarrow (\text{Sym}^k \text{Kl}_2)_{\widehat{0}} \quad \text{and} \quad \iota_{\infty} : \text{Sym}^k \text{Kl}_2 \rightarrow (\text{Sym}^k \text{Kl}_2)_{\infty}$$

denote the formalization of $\text{Sym}^k \text{Kl}_2$ at zero and infinity respectively, and $\widehat{\nabla}$ the induced connection. We can represent elements of $H_{\text{dR},c}^1(\mathbb{G}_m, \text{Sym}^k \text{Kl}_2)$ as pairs (\widehat{m}, η) as (see [Fresán et al. 2023, Corollary 3.5])

- $\widehat{m} = (\widehat{m}_0, \widehat{m}_{\infty})$ is a pair of formal germs in $(\text{Sym}^k \text{Kl}_2)_{\widehat{0}} \oplus (\text{Sym}^k \text{Kl}_2)_{\infty}$,
- η belongs to $\Gamma(\mathbb{G}_m, \Omega_{\mathbb{G}_m}^1 \otimes \text{Sym}^k \text{Kl}_2)$,

such that, denoting by $\widehat{\eta} = (\iota_{\widehat{0}}\eta, \iota_{\infty}\eta)$ the formal germ of η in

$$[\Omega_{\mathbb{P}^1, \widehat{0}}^1 \otimes (\text{Sym}^k \text{Kl}_2)_{\widehat{0}}] \oplus [\Omega_{\mathbb{P}^1, \infty}^1 \otimes (\text{Sym}^k \text{Kl}_2)_{\infty}],$$

\widehat{m} and η are related by $\widehat{\nabla}\widehat{m} = \widehat{\eta}$.

We can regard $H_{\text{dR},\text{mid}}^1(\mathbb{G}_m, \text{Sym}^k \text{Kl}_2)$ as the image of the natural morphism

$$H_{\text{dR},c}^1(\mathbb{G}_m, \text{Sym}^k \text{Kl}_2) \rightarrow H_{\text{dR}}^1(\mathbb{G}_m, \text{Sym}^k \text{Kl}_2)$$

sending a pair (\widehat{m}, η) to η . Recall that $H_{\text{dR},\text{mid}}^1(\mathbb{G}_m, \text{Sym}^k \text{Kl}_2)$ has dimension k' if k is not a multiple of 4, and $k' - 1$ otherwise; see [Fresán et al. 2022, Proposition 4.12]. According to [Fresán et al. 2023, Remark 3.6], there exists a basis of $H_{\text{dR},c}^1(\mathbb{G}_m, \text{Sym}^k \text{Kl}_2)$ consisting of

- pairs $(\widehat{m}_i, 0)_i$ where $(\widehat{m}_i)_i$ is a basis of $\ker \widehat{\nabla}$ in $(\text{Sym}^k \text{Kl}_2)_{\widehat{0}} \oplus (\text{Sym}^k \text{Kl}_2)_{\infty}$, and
- a set of pairs $(\widehat{m}_j, \eta_j)_j$, of cardinality $\dim H_{\text{dR},\text{mid}}^1(\mathbb{G}_m, \text{Sym}^k \text{Kl}_2)$, related as above such that $(\eta_j)_j$ are linearly independent in $H_{\text{dR}}^1(\mathbb{G}_m, \text{Sym}^k \text{Kl}_2)$.

Furthermore, such a family $(\eta_j)_j$ is a basis of $H_{\text{dR,mid}}^1(\mathbb{G}_m, \text{Sym}^k \text{Kl}_2)$.

We set (recall that $u_0 = v_0^k$)

$$\omega_i = [z^i u_0 dz/z] \in H_{\text{dR}}^1(\mathbb{G}_m, \text{Sym}^k \text{Kl}_2), \quad 0 \leq i \leq k'. \tag{3.2}$$

It was proved in [Fresán et al. 2022, Proposition 4.14] that

$$\mathcal{B}_k = \{\omega_i \mid 0 \leq i \leq k'\}$$

is a basis of $H_{\text{dR}}^1(\mathbb{G}_m, \text{Sym}^k \text{Kl}_2)$. This property also follows from the combination of Lemma 3.3, Proposition 3.8, and Theorem 3.17 below (see Remark 3.22).

We first determine which linear combinations of elements of \mathcal{B}_k belong to $H_{\text{dR,mid}}^1(\mathbb{G}_m, \text{Sym}^k \text{Kl}_2)$. For each $i = 0, \dots, k'$, we look for the existence of

$$\widehat{m}_i = (\widehat{m}_{i,0}, \widehat{m}_{i,\infty}) \in (\text{Sym}^k \text{Kl}_2)_{\widehat{0}} \oplus (\text{Sym}^k \text{Kl}_2)_{\infty}$$

such that $\widehat{\nabla} \widehat{m}_i = (\iota_{\widehat{0}}(\omega_i), \iota_{\infty}(\omega_i))$.

Lemma 3.3 (solutions at $z = 0$). (1) *The subspace $\ker \widehat{\nabla} \subset (\text{Sym}^k \text{Kl}_2)_{\widehat{0}}$ has dimension one and a basis is given by $\widehat{m}_{0,0} = e_0^k$.*

(2) *There exists $\widehat{m}_{i,0}$ if and only if $i \geq 1$ and, in such case, there exists a unique $\widehat{m}_{i,0}$ belonging to $z\mathbb{C}[[z]] \cdot \mathbf{u}$.*

In fact, for any $j \geq 1$, there exists a unique $\widehat{m}_{j,0} \in z\mathbb{C}[[z]] \cdot \mathbf{u}$ with $\widehat{\nabla} \widehat{m}_{j,0} = \iota_{\widehat{0}}(z^j u_0 dz/z)$.

Proof. Set $(V, \nabla) = (\text{Sym}^k \text{Kl}_2, \nabla)$. We first claim that $\mathbb{C}[[z]] \cdot \mathbf{u}$ is equal to $V_{\widehat{0},0}$ (the 0-th step of the formal Kashiwara–Malgrange filtration at the origin, similar to that considered in the proof of [Fresán et al. 2023, Proposition 3.2]). Indeed, it is standard to show that there exists a formal (in fact convergent) base change $P(z) = \text{Id} + zP_1 + \dots$ such that the matrix of $\widehat{\nabla}$ in the basis $\mathbf{u}' = \mathbf{u} \cdot P(z)$ is constant and equal to a lower standard Jordan block with eigenvalue 0. It follows that \mathbf{u}' is a $\mathbb{C}[[z]]$ -basis of $V_{\widehat{0},0}$, and the claim follows, as well as the first point of the lemma.

Let us consider the second point. Setting $V_{\widehat{0},-1} = zV_{\widehat{0},0}$, we have recalled in [loc. cit.] that $z\partial_z : V_{\widehat{0},-1} \rightarrow V_{\widehat{0},-1}$ is bijective. The “if” part and its supplement follow. It remains to check that $\iota_{\widehat{0}}(u_0 dz/z)$ does not belong to the image of $\widehat{\nabla}$. It amounts to the same to replace u_0 with u'_0 defined above, and since u'_0 is the primitive vector of the matrix of $\widehat{\nabla}$, the assertion follows. \square

We now look for the solutions of $\widehat{\nabla} \widehat{m}_{i,\infty} = \iota_{\infty}(\omega_i)$ for $i = 1, \dots, k'$. For this purpose, we introduce the constants $\gamma_{k,i}$ as follows. Let us assume that $4 \mid k$. Recall that we have set $w = 1/z$ on \mathbb{G}_m . Write the asymptotic expansion as

$$2^k (I_0(t)K_0(t))^{k/2} \sim w^{k/4} \sum_{j=0}^{\infty} \gamma_{k,k/4+j} w^j, \tag{3.4}$$

so that we can define $\gamma_{k,i}$ by the residue

$$\gamma_{k,i} = \text{res}_{w=0} \frac{2^k (I_0(t)K_0(t))^{k/2}}{w^{i+1}}. \tag{3.5}$$

We have $\gamma_{k,i} = 0$ if $i < k/4$, $\gamma_{k,k/4} = 1$, and $\gamma_{k,i} > 0$ for all $i \in k/4 + \mathbb{N}^*$, e.g.,

$$\gamma_{k,1+k/4} = \frac{k}{2^6}, \quad \gamma_{k,2+k/4} = \frac{k(k+52)}{2^{13}}, \quad \gamma_{k,3+k/4} = \frac{k(k^2 + 156k + 13184)}{2^{19} \cdot 3}, \quad \dots \tag{3.6}$$

For what follows, it will be convenient to set

$$\gamma_{k,i} = 0 \quad (i \in k/4 + \mathbb{Z}) \text{ if } 4 \nmid k. \tag{3.7}$$

Proposition 3.8 (solutions at $z = \infty$). *Let us fix $i \in \{1, \dots, k'\}$:*

- (1) *For $4 \nmid k$, the equation $\widehat{\nabla} \widehat{m}_{i,\infty} = \iota_\infty(\omega_i)$ has a unique solution.*
- (2) *For $4 \mid k$ and $i \neq k/4$, the equation*

$$\widehat{\nabla} \widehat{m}_{i,\infty} = \iota_\infty(\omega_i - \gamma_{k,i} \omega_{k/4})$$

has a solution (in fact a one-dimensional affine space of solutions) where $\gamma_{k,i}$ is given by (3.5). Moreover, the subspace $\ker \widehat{\nabla} \subset (\text{Sym}^k \text{Kl}_2)_\infty$ is generated by the formal expansion $\widehat{m}_{k/4,\infty}$ of $2^k(\pi i)^{k/2}(e_0 e_1)^{k/2}$.

In fact, for any $j \geq 1$, there exists $\widehat{m}_{j,\infty}$ satisfying $\widehat{\nabla} \widehat{m}_{j,\infty} = \iota_\infty(z^j - \gamma_{k,j} z^{k/4}) u_0 dz/z$.

The second assertion of 3.8(2) is easy to check from the formal structure at infinity of $\text{Sym}^k \text{Kl}_2$; see [Fresán et al. 2022, Proposition 4.6(3)]. We set

$$\begin{aligned} \widehat{m}_0 &= (\widehat{m}_{0,0}, 0) \text{ (i.e., } \widehat{m}_{0,\infty} = 0) && \text{for all } k, \\ \widehat{m}_{k/4} &= (0, \widehat{m}_{k/4,\infty}) \text{ (i.e., } \widehat{m}_{k/4,0} = 0) && \text{if } 4 \mid k, \end{aligned}$$

and (see Notation 1.4)

$$\omega'_i = \begin{cases} 0 & \text{if } i = 0 \text{ and } i = k/4, \\ \omega_i - \gamma_{k,i} \omega_{k/4} & \text{if } i \in \llbracket 1, k' \rrbracket, \end{cases} \tag{3.9}$$

so that $\omega'_i = \omega_i$ if $4 \nmid k$ and $1 \leq i \leq k'$, or if $4 \mid k$ and $1 \leq i < k/4$. Once we know that \mathcal{B}_k is a basis of $H_{\text{dR}}^1(\mathbb{G}_m, \text{Sym}^k \text{Kl}_2)$, using the convention (3.7) we derive the following from [Fresán et al. 2023, Remark 3.6(4)]:

Corollary 3.10. *The following set of $k' + 1$ elements*

$$\mathcal{B}_{k,c} = (\widehat{m}_i, \omega'_i)_{0 \leq i \leq k'} = \begin{cases} \{(\widehat{m}_0, 0), (\widehat{m}_1, \omega_1), \dots, (\widehat{m}_{k'}, \omega_{k'})\} & \text{if } 4 \nmid k, \\ \{(\widehat{m}_0, 0), (\widehat{m}_1, \omega'_1), \dots, (\widehat{m}_{k/4}, 0), \dots, (\widehat{m}_{k'}, \omega'_{k'})\} & \text{if } 4 \mid k, \end{cases}$$

is a basis of $H_{\text{dR},c}^1(\mathbb{G}_m, \text{Sym}^k \text{Kl}_2)$.

Let us consider the subset $\mathcal{B}_{k,\text{mid}}$ of the k' (resp. $(k' - 1)$) dimensional subspace $H_{\text{dR},\text{mid}}^1(\mathbb{G}_m, \text{Sym}^k \text{Kl}_2)$ of $H_{\text{dR}}^1(\mathbb{G}_m, \text{Sym}^k \text{Kl}_2)$ if $4 \nmid k$ (resp. if $4 \mid k$):

$$\mathcal{B}_{k,\text{mid}} = \begin{cases} \{\omega_i \mid i \in \llbracket 1, k' \rrbracket\} & \text{if } 4 \nmid k, \\ \{\omega'_i \mid i \in \llbracket 1, k' \rrbracket\} & \text{if } 4 \mid k. \end{cases}$$

Corollary 3.11. *The set $\mathcal{B}_{k,\text{mid}}$ is a basis of $H_{\text{dR},\text{mid}}^1(\mathbb{G}_m, \text{Sym}^k \text{Kl}_2)$.*

Remark 3.12. Part of this result can also be proved as a consequence of [Fresán et al. 2022, Proposition 4.21(2) and Theorem 1.8]. However, the present proof does not rely on Hodge theory.

Proof of Proposition 3.8. Recall that e_0, e_1 are defined by (2.15) and ω_i by (3.2). Let us set $\bar{e}_1 = \pi i e_1$. Then $v_0 = 2(K_0 e_0 + I_0 \bar{e}_1)$ and

$$\omega_i = - \sum_{a=0}^k \binom{k}{a} \frac{2^k I_0^a K_0^{k-a}}{w^i} e_0^{k-a} \bar{e}_1^a \frac{dw}{w}.$$

We have to examine if there exist $\xi_{i,a}$ in some extension of $\mathbb{C}((w))$ such that

$$w \partial_w \xi_{i,a} = -w^{-i} (2^k I_0^a K_0^{k-a}) \quad \text{and} \quad \sum_{a=0}^k \binom{k}{a} \xi_{i,a} e_0^{k-a} \bar{e}_1^a \in (\text{Sym}^k \text{Kl}_2)_\infty \quad \text{if } 4 \nmid k,$$

and a similar property in the case $4 \mid k$. Then one takes

$$\widehat{m}_{i,\infty} = \sum_{a=0}^k \binom{k}{a} \xi_{i,a} e_0^{k-a} \bar{e}_1^a.$$

We write

$$\frac{2^k I_0^a K_0^{k-a}}{w^i} \sim \begin{cases} \sqrt{\pi}^{k-2a} e^{-2(k-2a)/\sqrt{w}} w^{k/4-i} \cdot F_a & a \neq k/2, \\ w^{k/4-i} \left(\sum_{n=0}^\infty \frac{((2n-1)!!)^3}{2^{5n} n!} w^n \right)^{k/2} & a = k/2, \end{cases}$$

with $F_a \in 1 + \sqrt{w}\mathbb{Q}[[\sqrt{w}]]$. When $a \neq k/2$ there exists a unique $\xi_{i,a}$ with the expansion

$$\xi_{i,a} \sim \frac{\sqrt{\pi}^{k-2a}}{(k-2a)} e^{-2(k-2a)/\sqrt{w}} w^{k/4-i+1/2} \cdot G_{i,a} \tag{3.13}$$

for some $G_{i,a} \in -1 + \sqrt{w}\mathbb{Q}[[\sqrt{w}]]$. Moreover, when expressed as a combination of monomials $v_0^{k-b} v_1^b$, such $\xi_{i,a} e_0^{k-a} \bar{e}_1^a$ has no exponential factor and, if σ denotes the action $w^{1/4} \mapsto iw^{1/4}$ so that $\mathbb{C}((w)) = \mathbb{C}((w^{1/4}))^\sigma$, one has $\sigma(\xi_{i,a} e_0^{k-a} \bar{e}_1^a) = \xi_{i,k-a} e_0^a \bar{e}_1^{k-a}$. When $4 \mid (k+2)$ and $a = k/2$, the exponents of w in the expansion of $2^k w^{-i-1} I_0^a K_0^{k-a}$ are in $\frac{1}{2} + \mathbb{Z}$ and one takes $\xi_{i,k/2}$ satisfying

$$\xi_{i,k/2} \sim \frac{w^{k/4-i}}{(k/4-i)} \cdot G_i$$

with $G_i \in -1 + w\mathbb{Q}[[w]]$. Then the factor $\xi_{i,k/2} (e_0 \bar{e}_1)^{k/2}$ has no exponential part in its expression in terms of v_0, v_1 and is invariant under σ . Finally, when $4 \mid k, k \geq 8$ and $a = k/2$, the residue

$$\gamma_{k,i} = \text{res}_{w=0} \frac{2^k I_0^{k/2} K_0^{k/2}}{w^{i+1}},$$

vanishes if and only if $i < k/4$. Therefore, for $i \geq k/4$ there exists $\xi_{i,k/2} \in \mathbb{Q}((w))$ such that

$$w \partial_w \xi_{i,k/2} = -(w^{-i} - \gamma_{k,i} w^{-k/4}) (I_0 K_0)^{k/2} dw.$$

In this case, $\xi_{i,k/2} (e_0 \bar{e}_1)^{k/2}$ has no exponential factor in combinations of v_0, v_1 and is invariant under σ . The proof is complete. □

Remark 3.14. In the case where $4 \nmid k$, the $\widehat{m}_{i,\infty}$ are uniquely determined since there is no horizontal formal section at $z = \infty$. When $4 \mid k$, the $\widehat{m}_{i,\infty}$ are unique up to adding a multiple of the formal horizontal section $\widehat{m}_{k/4,\infty}$ defined in Proposition 3.8(2). To normalize the choice, we take the series $\xi_{i,k/2}$ above to have no constant term. This normalization then fixes the computations of periods below.

3.2. Computation of the de Rham pairing. We aim at computing the matrix S_k^{mid} of the pairing

$$H_{\text{dR,mid}}^1(\mathbb{G}_m, \text{Sym}^k \text{Kl}_2) \otimes H_{\text{dR,mid}}^1(\mathbb{G}_m, \text{Sym}^k \text{Kl}_2) \rightarrow \mathbb{C}$$

induced by the self-duality pairing (2.7), with respect to the basis $\mathcal{B}_{k,\text{mid}}$. By [Fresán et al. 2023, Proposition 3.12], the matrix S_k^{mid} is equal to the sum of the matrices having (i, j) entries respectively:

- If $4 \nmid k$ and $i, j = 1, \dots, k'$,

$$\text{res}_{z=0} \langle \widehat{m}_{i,0}, z^j u_0 dz/z \rangle_{\text{alg}} \quad \text{and} \quad -\text{res}_{w=0} \langle \widehat{m}_{i,\infty}, w^{-j} u_0 dw/w \rangle_{\text{alg}}.$$

- A similar formula following Proposition 3.8(2) if $4 \mid k$.

For $i \in \{1, \dots, k'\}$ we set

$$\widehat{m}_{i,\infty} = \sum_{a=0}^k \mu_{a,i}(w) u_a, \quad \mu_{a,i}(w) = \sum_{\ell \gg -\infty} \mu_{a,i,\ell} w^\ell.$$

We can already note that, according to Lemma 3.3, $\langle \widehat{m}_{i,0}, z^j u_0 dz/z \rangle_{\text{alg}}$ has no residue (and a similar assertion if $4 \mid k$) so S_k^{mid} is determined by the residues at infinity. It follows from (2.7) that, if $4 \nmid k$, we have

$$S_{k;i,j}^{\text{mid}} = (-1)^{k+1} \mu_{k,i,j}, \quad i, j = 1, \dots, k'. \tag{3.15}$$

If $4 \mid k$, S_k^{mid} is the $(k' - 1) \times (k' - 1)$ -matrix given by the formula

$$S_{k;i,j}^{\text{mid}} = (-1)^{k+1} \begin{cases} \mu_{k,i,j} & \text{if } i \text{ or } j < k/4, \\ (\mu_{k,i,j} - \gamma_{k,j} \mu_{k,i,k/4}) & \text{if } i \text{ and } j > k/4, \end{cases} \quad i, j \in \llbracket 1, k' \rrbracket. \tag{3.16}$$

In other words, in the matrix given by (3.15) we delete the row $i = k/4$ and the column $j = k/4$ and we add to it the matrix having entry (i, j) equal to $(-1)^k \gamma_{k,j} \mu_{k,i,k/4}$ for $i, j > k/4$. According to [Fresán et al. 2023, Corollary 3.14] and (2.7), the matrix S_k^{mid} is $(-1)^{k+1}$ -symmetric.

Theorem 3.17. *The matrix S_k^{mid} is lower-right triangular (i.e., the entries (i, j) are zero if $i + j \leq k'$) and the antidiagonal entry on the i -th row is equal to*

$$\begin{cases} (-2)^k \frac{k'!}{k'!!} & \text{if } k \text{ is odd,} \\ \frac{(-1)^{k'+1}}{2^{k'}(k'+1-2i)} \cdot \frac{(k-1)!!}{(k'+1)!} & \text{if } k \text{ is even.} \end{cases}$$

Proof. We keep notation from the proof of [Proposition 3.8](#). For odd k , the entries of S_k^{mid} are

$$\begin{aligned} \text{res}_{w=0} \langle \widehat{m}_{i,\infty}, \omega_j \rangle_{\text{alg}} &= - \sum_{a,b=0}^k \binom{k}{a} \binom{k}{b} \text{res}_{w=0} \left\langle \xi_{i,a} e_0^{k-a} \bar{e}_1^a, \frac{2^k I_0^b K_0^{k-b}}{w^{j+1}} e_0^{k-b} \bar{e}_1^b \, dw \right\rangle_{\text{alg}} \\ &= - \frac{1}{2^k} \sum_{a,b=0}^k \binom{k}{a} \binom{k}{b} \text{res}_{w=0} \left\langle \xi_{i,a} e_0^{k-a} e_1^a, \frac{2^k I_0^b K_0^{k-b}}{w^{j+1}} e_0^{k-b} e_1^b \, dw \right\rangle_{\text{top}} \\ &= - \frac{1}{2^k} \sum_{a=0}^k (-1)^a \binom{k}{a} \text{res}_{w=0} \left(\xi_{i,a} \frac{2^k I_0^{k-a} K_0^a}{w^{j+1}} \, dw \right) \\ &= - \frac{1}{2^k} \sum_{a=0}^k \frac{(-1)^a \binom{k}{a}}{k-2a} \text{res}_{w=0} (w^{k'-i-j} F_{k-a} G_{i,a} \, dw) \end{aligned}$$

where $F_{k-a}, -G_{i,a} \in 1 + \sqrt{w}\mathbb{Q}[[\sqrt{w}]]$. Clearly, the last residue vanishes if $i + j \leq k'$. If $i + j = k' + 1$, we find

$$\text{res}_{w=0} \langle \widehat{m}_{i,\infty}, \omega_j \rangle = 2^{-k} \sum_{a=0}^k \frac{(-1)^a \binom{k}{a}}{k-2a}.$$

We conclude the case where k is odd with the next lemma.

Lemma 3.18. *For any $k \geq 1$, we have*

$$\sum_{\substack{0 \leq a \leq k \\ a \neq k/2}} \frac{(-1)^a \binom{k}{a}}{k-2a} = \begin{cases} 2^k (-2)^{k'} \frac{k'!}{k!!} & \text{if } k \text{ is odd,} \\ 0 & \text{if } k \text{ is even.} \end{cases}$$

Proof. If k is even, replacing a with $k - a$ in the sum shows that the sum is equal to its opposite, and hence vanishes. We thus assume that k is odd and set

$$f_k(x) = \sum_{a=0}^k \binom{k}{a} \frac{x^{k-2a}}{k-2a}.$$

Then $f_k(x) = \int_1^x (x + 1/x)^k \, dx/x$. Besides, one has

$$\begin{aligned} f_k(x) &= \int_0^{\log x} (e^t + e^{-t})^k \, dt = 2^k \int_0^{\log x} \cosh^k t \, dt \quad (x = e^t) \\ &= 2^k \left[\frac{\sinh t \cosh^{k-1} t}{k} \Big|_{t=\log x} + \frac{k-1}{k} \int_0^{\log x} \cosh^{k-2} t \, dt \right] \\ &= \frac{1}{k} \left(x - \frac{1}{x} \right) \left(x + \frac{1}{x} \right)^{k-1} + 4 \frac{k-1}{k} f_{k-2}(x). \end{aligned}$$

By evaluating $f_k(i)$ inductively, one obtains the desired equality. □

Assume $4 \mid (k + 2)$, so that $k/2 = k' + 1$ is odd. Then the entries of S_k^{mid} are

$$\begin{aligned} & \text{res}_{w=0} \langle \widehat{m}_{i,\infty}, \omega_j \rangle \\ &= -\frac{1}{2^k} \left[\sum_{a \neq k/2} (-1)^a \binom{k}{a} \text{res}_{w=0} \left(\xi_{i,a} \frac{2^k I_0^{k-a} K_0^a}{w^{j+1}} dw \right) - \binom{k}{k/2} \text{res}_{w=0} \left(\xi_{i,k/2} \frac{2^k (I_0 K_0)^{k/2}}{w^{j+1}} dw \right) \right] \\ &= -\frac{1}{2^k} \left[\sum_{a \neq k/2} \frac{(-1)^a \binom{k}{a}}{(k-2a)} \text{res}_{w=0} (w^{k'-i-j+1/2} F_{k-a} G_{i,a} dw) - \frac{2 \binom{k}{k/2}}{(k'+1-2i)} \text{res}_{w=0} (w^{k'-i-j} F G_i dw) \right], \end{aligned}$$

where

$$F(w) = \left(\sum_{n=0}^{\infty} \frac{((2n-1)!!)^3}{2^{5n} n!} w^n \right)^{k/2}.$$

Again, the residue is zero if $i + j \leq k'$. On the other hand, if $i + j = k' + 1$, the first term in the above expression is zero, according to the lemma above, and since $F(0) = 1$ and $G_i(0) = -1$, we have

$$\text{res}_{w=0} \langle \widehat{m}_{i,\infty}, \omega_j \rangle = -\binom{k}{k/2} [2^{k-1} (k' + 1 - 2i)]^{-1}.$$

The computation in the case where $4 \nmid k$ is similar. □

Example 3.19 ($k = 5$). We have $k' = 2$ and

$$S_5^{\text{mid}} = \begin{pmatrix} 0 & 8/15 \\ 8/15 & \mu_{5,2,2} \end{pmatrix}.$$

From the proof of the theorem above, one has

$$\mu_{5,2,2} = \frac{-1}{2^5} \sum_{a=0}^5 \frac{(-1)^a \binom{5}{a}}{5-2a} \text{res}_{w=0} \left(F_{5-a} G_{2,a} \frac{dw}{w^2} \right).$$

A direct computation yields

$$-\sum_{a=0}^5 \frac{(-1)^a \binom{5}{a}}{5-2a} F_{5-a} G_{2,a} \sim \frac{256}{15} + \frac{2^9 \cdot 13}{3^3 \cdot 5^5} w \pmod{w^2 \mathbb{Q}[[w]]}.$$

Therefore,

$$S_5^{\text{mid}} = \begin{pmatrix} 0 & 8/15 \\ 8/15 & 2^4 \cdot 13/3^3 \cdot 5^3 \end{pmatrix}.$$

Example 3.20 ($k = 6$). We have $k' = 2$ and $i = 1, 2$. Due to skew-symmetry, the antidiagonal entries are enough to determine S_6^{mid} . [Theorem 3.17](#) gives

$$S_6^{\text{mid}} = \begin{pmatrix} 0 & -5/8 \\ 5/8 & 0 \end{pmatrix}.$$

Corollary 3.21. *The ordered basis $\mathcal{B}_{k,\text{mid}}$ of $H_{\text{dr,mid}}^1(\mathbb{G}_m, \text{Sym}^k \text{Kl}_2)$ is adapted to the Hodge filtration.*

Proof. For odd k , [Fresán et al. 2022, Proposition 4.21(2) and Theorem 1.8(1)] imply the claim. For even k , [loc. cit.] only gives compatibility for half of the basis $\mathcal{B}_{k,\text{mid}}$. However, since the Poincaré pairing respects the Hodge filtration, compatibility holds for the whole $\mathcal{B}_{k,\text{mid}}$ by the above theorem. \square

Remark 3.22 (the matrix S_k). The matrix of the pairing

$$S_k : H_{\text{dR},c}^1(\mathbb{G}_m, \text{Sym}^k \text{Kl}_2) \otimes H_{\text{dR}}^1(\mathbb{G}_m, \text{Sym}^k \text{Kl}_2) \rightarrow \mathbb{C}$$

in the basis $\mathcal{B}_{k,c} \otimes \mathcal{B}_k$ is obtained with similar residue formulas as for S_k^{mid} , due to [Fresán et al. 2023, Proposition 3.12]:

(1) If $4 \nmid k$,

$$S_{k;i,j} = \begin{cases} S_{k;i,j}^{\text{mid}} & \text{if } 1 \leq i, j \leq k', \\ 0 & \text{if } i = 0 \text{ and } j = 1, \dots, k'. \end{cases}$$

On the other hand, we have $S_{k;0,0} = \text{res}_{z=0} \langle e_0^k, u_0 dz/z \rangle_{\text{alg}} = 1$. Last, for $i \geq 1$, we use the expressions (2.15) and obtain

$$\begin{aligned} S_{k;i,0} &= \text{res}_{w=0} \left\langle \widehat{m}_{i,\infty}, u_0 \frac{dz}{z} \right\rangle_{\text{alg}} \\ &= \sum_{a=0}^k \binom{k}{a} \text{res}_{w=0} \left\langle \xi_{i,a} e_0^{k-a} \bar{e}_1^a, u_0 \frac{dz}{z} \right\rangle_{\text{alg}} \\ &= \sum_{a=0}^k \binom{k}{a} \text{res}_{w=0} \left\langle \xi_{i,a} \left[\frac{t}{2} I_0' v_0 - I_0 v_1 \right]^{k-a} \left[-\frac{t}{2} K_0' v_0 + K_0 v_1 \right]^a, u_0 \frac{dz}{z} \right\rangle_{\text{alg}} \\ &= \sum_{a=0}^k (-1)^a \binom{k}{a} \text{res}_{w=0} \xi_{i,a} I_0^{k-a} K_0^a \frac{dz}{z}. \end{aligned}$$

Since

$$\xi_{i,a} I_0^{k-a} K_0^a \sim \begin{cases} \frac{1}{2^k (k-2a)} w^{(k+1)/2-i} G_{i,a} & a \neq k/2, \\ \frac{1}{2^k (k/4-i)} w^{k/2-i} G_i & a = k/2 \end{cases}$$

with $G_{i,a}, G_i \in \mathbb{Q}[[\sqrt{w}]]$, we conclude that $S_{k;i,0} = 0$. In other words, S_k takes the form

$$\begin{pmatrix} 1 & 0 \\ 0 & S_k^{\text{mid}} \end{pmatrix}.$$

In particular, we get

$$\det S_k = \det S_k^{\text{mid}} = \begin{cases} (-1)^{k'(k'+1)/2} (2^{k'} k'! / k!!)^{k'} & \text{if } k \text{ is odd,} \\ ((k-1)!!)^{k'} / [(2^{k'} (k'+1)!)^{k'} ((k'-1)!!)^2] & \text{if } 4 \mid (k+2). \end{cases}$$

(2) If $4 \mid k$, the matrix S_k is obtained from the matrix $\begin{pmatrix} 1 & 0 \\ 0 & S_k^{\text{mid}} \end{pmatrix}$ by adding a row $i = k/4$ and a column $j = k/4$ that we compute now. For the row $i = k/4$, we note that

$$\langle \widehat{m}_{k/4,\infty}, v_0^k \rangle_{\text{alg}} = 2^k (I_0 K_0)^{k/2} = w^{k/4} \sum_{j \geq 0} \gamma_{k,k/4+j} w^j,$$

so that

$$S_{k;k/4,k/4+j} = \begin{cases} 0 & \text{if } j < 0, \\ -\gamma_{k,k/4+j} & \text{if } j \geq 0. \end{cases}$$

For the column $j = k/4$, we compute as above that $S_{k;0,k/4} = 0$ and, for $i \geq 1$ and $\neq k/4$,

$$S_{k;i,k/4} = \text{res}_{z=\infty} \langle \widehat{m}_{i,\infty}, \omega_{k/4} \rangle_{\text{alg}}.$$

In particular, by setting $k'' = \lfloor (k - 1/4) \rfloor$ and recalling $\gamma_{k,k/4} = 1$, we get

$$\det S_k = -\det S_k^{\text{mid}} = -[2^{-k'-1}(k-1)!((k'+1)!)^{-1}]^{k'-1}(k'!)^{-2}. \tag{3.23}$$

4. Betti intersection pairing for $\text{Sym}^k \text{Kl}_2$

In this section, we exhibit natural bases of the rapid decay, the moderate growth, and the middle homology spaces denoted respectively by

$$H_1^{\text{rd}}(\mathbb{G}_m, \text{Sym}^k \text{Kl}_2), \quad H_1^{\text{mod}}(\mathbb{G}_m, \text{Sym}^k \text{Kl}_2), \quad \text{and} \quad H_1^{\text{mid}}(\mathbb{G}_m, \text{Sym}^k \text{Kl}_2).$$

We then compute the Betti pairing B_k as introduced in [Fresán et al. 2023, Section 2.d]. Bear in mind that the notation there keeps track of the degree of the homology spaces; as this degree is always equal to 1 here, we omit it, but we remember the exponent k of the symmetric power. We keep the setting of Section 2.3. While we used $\langle \cdot, \cdot \rangle_{\text{alg}}$ on $\text{Sym}^k \text{Kl}_2$ to compute the de Rham intersection matrix S_k , we will use the topological pairing $\langle \cdot, \cdot \rangle_{\text{top}}$ on $\text{Sym}^k \text{Kl}_2^\vee$ to compute the Betti pairing B_k , which is thus defined over \mathbb{Q} .

We consider the following C^∞ chains on \mathbb{P}_z^1 diffeomorphic to their images:

- $\mathbb{R}_+ = [0, \infty]$, oriented from 0 to $+\infty$,
- $c_0 =$ unit circle, starting at 1 and oriented counterclockwise,
- $c_+ = [1, \infty]$, oriented from +1 to $+\infty$.

According to Lemma 2.19, the $\lfloor k/2 \rfloor + 1$ twisted chains

$$\beta_j = \mathbb{R}_+ \otimes e_0^j e_1^{k-j}, \quad 0 \leq j \leq \lfloor k/2 \rfloor,$$

have moderate growth and define $\lfloor k/2 \rfloor + 1$ elements of $H_1^{\text{mod}}(\mathbb{G}_m, \text{Sym}^k \text{Kl}_2)$, still denoted by β_j .

Besides, the twisted chain $\alpha_0 = c_0 \otimes e_0^k$ is a twisted cycle with compact support, and hence has rapid decay, since e_0 is invariant by monodromy. We obtain other twisted chains with compact support as follows. For each integer $n \geq 1$, let us set

$$C_n(a) = \frac{(-1)^{a-1}}{na} \binom{n}{a}, \quad 1 \leq a \leq n.$$

Lemma 4.1. *Let $n \geq 1$ be an integer:*

(1) *The sequence $(C_n(a))_a$ is the unique solution to the linear relations*

$$\sum_{a=1}^n C_n(a)a = \frac{1}{n} \quad \text{and} \quad \sum_{a=1}^n C_n(a)a^r = 0 \quad \text{if } 2 \leq r \leq n.$$

(2) *The sequence $(C_n(a))_a$ is the unique solution to the linear relations*

$$\sum_{a=1}^n C_n(a)a^{n+1} = (-1)^{n-1}(n-1)! \quad \text{and} \quad \sum_{a=1}^n C_n(a)a^r = 0 \quad \text{if } 2 \leq r \leq n.$$

Proof. Direct simplification of Cramer’s rule in solving the systems of linear equations. □

Lemma 4.2. *For integers $n \geq 1$ and $r \geq 0$, one has*

$$\sum_{a=1}^{n+r} C_{n+r}(a) \sum_{b=1}^a b^n = \begin{cases} \frac{(-1)^n}{n+r} \mathcal{B}_n & \text{if } r \geq 1, \\ \frac{(-1)^n}{n} \mathcal{B}_n + (-1)^{n-1} \frac{(n-1)!}{n+1} & \text{if } r = 0. \end{cases}$$

Proof. Replacing $\sum_{b=1}^a b^n$ with Bernoulli’s formula

$$\sum_{b=1}^a b^n = \frac{1}{n+1} \sum_{\ell=0}^n (-1)^\ell \binom{n+1}{\ell} \mathcal{B}_\ell a^{n+1-\ell}, \tag{4.3}$$

we can rewrite the left-hand side as

$$\sum_{a=1}^{n+r} C_{n+r}(a) \sum_{b=1}^a b^n = \frac{1}{n+1} \sum_{\ell=0}^n (-1)^\ell \binom{n+1}{\ell} \mathcal{B}_\ell \sum_{a=1}^{n+r} C_{n+r}(a)a^{n+1-\ell}.$$

Then [Lemma 4.1\(1\)](#) gives the assertion for $r \geq 1$ and, for $r = 0$, we use [Lemma 4.1\(2\)](#) instead. □

Since $T^a e_1 = e_1 + a e_0$ for all $a \geq 1$, it follows from [Lemma 4.1\(1\)](#) that, for each $1 \leq i \leq k$, the twisted chain with compact support

$$\sum_{a=1}^{k-i+1} C_{k-i+1}(a) c_0^a \otimes e_0^{i-1} e_1^{k-i+1}$$

has boundary $\{1\} \otimes e_0^i e_1^{k-i}$. As a consequence, the following $(k' + 1)$ twisted chains are twisted cycles, whose classes are elements in $H_1^{\text{rd}}(\mathbb{G}_m, \text{Sym}^k \text{Kl}_2)$:

$$\begin{cases} \alpha_0 = c_0 \otimes e_0^k \\ \alpha_i = -\frac{(-1)^{k-i}(k-i)!}{k-i+2} \alpha_0 + c_+ \otimes e_0^i e_1^{k-i} + \sum_{a=1}^{k-i+1} C_{k-i+1}(a) c_0^a \otimes e_0^{i-1} e_1^{k-i+1} \quad (1 \leq i \leq k'). \end{cases} \tag{4.4}$$

The natural map

$$H_1^{\text{rd}}(\mathbb{G}_m, \text{Sym}^k \text{Kl}_2) \rightarrow H_1^{\text{mod}}(\mathbb{G}_m, \text{Sym}^k \text{Kl}_2)$$

is given on these twisted cycles by

$$\alpha_i \mapsto \begin{cases} 0 & \text{if } i = 0, \\ \beta_i & \text{if } 1 \leq i \leq k' \end{cases} \tag{4.5}$$

by shrinking the circle c_0 and extending the half-line c_+ .

Proposition 4.6. *If $0 \leq j \leq \lfloor k/2 \rfloor$, we have $B_k(\alpha_0, \beta_j) = -\delta_{0,j}$ and, if $1 \leq i \leq k'$,*

$$B_k(\alpha_i, \beta_j) = (-1)^{k-i} \frac{(k-i)!(k-j)!}{k!} \frac{B_{k-i-j+1}}{(k-i-j+1)!}.$$

With a small abuse of notation, we also denote by B_k the matrix $(B_{k;i,j})_{1 \leq i,j \leq k'}$ with

$$B_{k;i,j} = B_k(\alpha_i, \beta_j).$$

Proof. For the first assertion, since the intersection index (c_0, \mathbb{R}_+) is equal to -1 , we have by (2.18)

$$B_k(\alpha_0, \beta_j) = \begin{cases} -\langle e_0^k, e_0^j e_1^{k-j} \rangle_{\text{top}} = 0 & \text{if } j \neq 0, \\ -\langle e_0^k, e_1^k \rangle_{\text{top}} = -1 & \text{if } j = 0. \end{cases}$$

Let us compute $B_k(\alpha_i, \beta_j)$ if $1 \leq i \leq k'$ and $0 \leq j \leq \lfloor k/2 \rfloor$. Fix some $\theta_o \in (0, \pi)$ and let $x_o = \exp(i\theta_o)$. To achieve the computation, we move the ray c_+ by adding the scalar $(x_o - 1)$ and let the circle c_0 start at x_o . Then the component $c_0^a \otimes e_0^{i-1} e_1^{k-i+1}$ in the deformed α_i meets β_j physically a times at the same point $1 \in \mathbb{C}^\times$ with intersection index -1 . At the b -th intersection ($1 \leq b \leq a$), the factor $e_0^{i-1} e_1^{k-i+1}$ becomes $e_0^{i-1} (e_1 + be_0)^{k-i+1}$ and (2.18) gives

$$\langle e_0^{i-1} (e_1 + be_0)^{k-i+1}, e_0^j e_1^{k-j} \rangle_{\text{top}} = (-1)^j \binom{k-j+1}{j} \binom{k}{j}^{-1} b^{k-i-j+1}.$$

For $j \geq 1$, since $B_k(\alpha_0, \beta_j) = 0$, we obtain, by adding these contributions and taking into account the intersection indices,

$$B_k(\alpha_i, \beta_j) = (-1)^{j+1} \binom{k-i+1}{j} \binom{k}{j}^{-1} \sum_{a=1}^{k-i+1} C_{k-i+1}(a) \sum_{b=1}^a b^{k-i-j+1}.$$

The asserted equality follows by applying Lemma 4.2 with $r \geq 1$.

If $j = 0$, then $B_k(\alpha_i, \beta_j)$ writes

$$\frac{(-1)^{k-i} (k-i)!}{k-i+2} - \sum_{a=1}^{k-i+1} C_{k-i+1}(a) \sum_{b=1}^a b^{k-i+1} = (-1)^{k-i} \frac{B_{k-i+1}}{k-i+1},$$

after Lemma 4.2 with $r = 0$. □

Theorem 4.7. (1) *The family $(\alpha_i)_{0 \leq i \leq k'}$ is a basis of $H_1^{\text{rd}}(\mathbb{G}_m, \text{Sym}^k \text{Kl}_2)$.*

(2) *The family (β_j) with $0 \leq j \leq k'$ (resp. with $0 \leq j \leq k'+1$ and $j \neq 1$) is a basis of $H_1^{\text{mod}}(\mathbb{G}_m, \text{Sym}^k \text{Kl}_2)$ if $4 \nmid k$ (resp. if $4 \mid k$).*

(3) *The family (β_j) with $1 \leq j \leq k'$ (resp. with $2 \leq j \leq k'$) is a basis of $H_1^{\text{mid}}(\mathbb{G}_m, \text{Sym}^k \text{Kl}_2)$ if $4 \nmid k$ (resp. if $4 \mid k$).*

Notation 4.8. If $4 \mid k$, we shift the indices of the bases α and β as follows:

$$\text{for } i \in \llbracket 1, k' \rrbracket, \quad \alpha'_i = \begin{cases} \alpha_{i+1} & \text{if } i < k/4, \\ \alpha_i & \text{if } i > k/4, \end{cases}$$

and similarly for β' . We set $B_k^{\text{mid}} = (B_{k;i,j}^{\text{mid}})_{i,j \in \llbracket 1, k' \rrbracket}$ with

$$B_{k;i,j}^{\text{mid}} = \begin{cases} B_k(\alpha_i, \beta_j) & \text{if } 4 \nmid k, \\ B_k(\alpha'_i, \beta'_j) & \text{if } 4 \mid k. \end{cases}$$

In particular, $B_k^{\text{mid}} = B_k$ if $4 \nmid k$. **Theorem 4.7(3)** implies that B_k^{mid} is an invertible matrix.

Theorem 4.7 is a straightforward consequence of **Propositions 4.6** and **4.9** below.

Proposition 4.9. (1) Let B_k denote the matrix of size k' having entries $B_k(\alpha_i, \beta_j)$ with

- $1 \leq i, j \leq k'$ if $4 \nmid k$,
- $1 \leq i \leq k'$ and $2 \leq j \leq k/2$ if $4 \mid k$.

Then

$$\det B_k = \begin{cases} [k! \prod_{a=1}^{k'} \binom{k}{a}]^{-1} & \text{if } k \text{ is odd,} \\ [k!(k'+1) \prod_{a=1}^{k'} \binom{k}{a}]^{-1} & \text{if } 4 \mid (k+2), \\ [k! \prod_{a=2}^{k'} \binom{k}{a}]^{-1} & \text{if } 4 \mid k. \end{cases}$$

(2) If $4 \mid k$, let B'_k denote the matrix of size $k' - 1$ having entries $B_k(\alpha_i, \beta_j)$ with $2 \leq i, j \leq k'$. Then

$$\det B'_k = \left[\frac{k}{4} (k')^2 \prod_{a=2}^{k'} \binom{k}{a} \right]^{-1}.$$

(Note that $B_k^{\text{mid}} = B_k$ if $4 \nmid k$ and $B_k^{\text{mid}} = B'_k$ if $4 \mid k$).

Some determinants of Bernoulli numbers. We will make use of the following lemma:

Lemma 4.10. *The following identities hold:*

$$\det \left(\frac{B_{i+j}}{(i+j)!} \right)_{1 \leq i, j \leq n} = \frac{(-1)^{n(n-1)/2} (2n+1)!!}{2^{n(n+1)} [3!!5!! \cdots (2n+1)!!]^2}. \tag{4.11}$$

$$\det \left(\frac{B_{i+j+1}}{(i+j+1)!} \right)_{1 \leq i, j \leq n} = \begin{cases} \frac{(-1)^{n/2}}{2^{n(n+2)} [3!!5!! \cdots (2n+1)!!]^2} & \text{if } n \text{ is even,} \\ 0 & \text{if } n \text{ is odd.} \end{cases} \tag{4.12}$$

Proof. We follow the principle in [Krattenthaler 2005, Section 5.4]. Recall that, for each $n \geq 0$, the Lommel polynomials $h_{n,\nu}(x)$ satisfy

$$J_{\nu+n}(z) = h_{n,\nu}(z^{-1})J_\nu(z) - h_{n-1,\nu+1}(z^{-1})J_{\nu-1}(z),$$

where $J_\nu(z)$ is the Bessel function of the first kind of order ν . Let

$$f_n(x) = \frac{1}{(2n+1)!!} h_{n,1/2}(x) \in \mathbb{Q}[x] \quad (n \geq 0).$$

The following hold:

- $f_n(x)$ is monic of degree n with $f_0(x) = 1$, $f_1(x) = x$, and $\{f_n(x)\}$ satisfies the recursive relation

$$f_{n+1}(x) = xf_n(x) - b_n f_{n-1}(x), \quad b_n = \frac{1}{(2n+1)(2n+3)}, \quad n \geq 1.$$

- $\{f_n(x)\}$ forms an orthogonal family with respect to the linear functional

$$L(f(x)) = \sum_{m=1}^{\infty} \frac{1}{(m\pi)^2} (f(1/m\pi) + f(-1/m\pi)).$$

For the above; see [Koelink and Van Assche 1995, Section 1]. We have the moments $\mu_r = L(x^r)$ of the linear functional

$$\mu_r = \frac{1}{\pi^{r+2}} \sum_{m=1}^{\infty} \frac{1}{m^{r+2}} + \frac{1}{(-m)^{r+2}} = \frac{(-1)^{r/2} 2^{r+2} \mathcal{B}_{r+2}}{(r+2)!} \geq 0, \quad r \geq 0$$

(in particular, $\mu_0 = \frac{1}{3}$). With these data and by applying [Krattenthaler 2005, Theorem 29], one readily obtains

$$\det(\mu_{i+j})_{0 \leq i, j \leq n-1} = \frac{(2n+1)!!}{[3!!5!! \dots (2n+1)!!]^2}, \quad \det(\mu_{i+j+1})_{0 \leq i, j \leq n-1} = \begin{cases} \frac{(-1)^{n/2}}{[3!!5!! \dots (2n+1)!!]^2} & \text{if } n \text{ is even,} \\ 0 & \text{if } n \text{ is odd.} \end{cases}$$

The asserted formulas follow immediately by a simple matrix manipulation. □

Remark 4.13. Let

$$\Theta_n = \left(\frac{\mathcal{B}_{2a+2b-2}}{(2a+2b-2)!} \right)_{1 \leq a, b \leq n}, \quad \Theta'_n = \left(\frac{\mathcal{B}_{2a+2b}}{(2a+2b)!} \right)_{1 \leq a, b \leq n}.$$

By rearranging columns and rows, one has

$$\begin{aligned} \left(\frac{\mathcal{B}_{i+j}}{(i+j)!} \right)_{1 \leq i, j \leq n} &\sim \begin{cases} \Theta_{n/2} \oplus \Theta'_{n/2} & \text{if } n \text{ is even,} \\ \Theta_{n+1/2} \oplus \Theta'_{(n-1/2)} & \text{if } n \text{ is odd,} \end{cases} \\ \left(\frac{\mathcal{B}_{i+j+1}}{(i+j+1)!} \right)_{1 \leq i, j \leq n} &\sim \begin{cases} \begin{pmatrix} 0 & \Theta'_{n/2} \\ \Theta'_{n/2} & 0 \end{pmatrix} & \text{if } n \text{ is even,} \\ \text{singular} & \text{if } n \text{ is odd.} \end{cases} \end{aligned}$$

Therefore, (4.11) inductively implies the equalities

$$\det \Theta_n = \frac{1}{2^{2n^2} 3!!5!! \dots (4n-1)!!}, \quad \det \Theta'_n = \frac{(-1)^n}{2^{2n(n+1)} 3!!5!! \dots (4n+1)!!}$$

and (4.12) is a consequence of (4.11). The evaluation of a variant of $\det \Theta_n$ is also considered in [Zhang and Chen 2014, Corollary 2], although their formula does not seem to be correct. Both this approach and that of [loc. cit.] use the orthogonal family of Lommel polynomials.

Proof of Proposition 4.9. Let $\Delta_n = (\delta_{n+1}(i+j))_{1 \leq i, j \leq n}$. For integers m, n with $m \geq n \geq 0$, let

$$D_{m,n}^\pm = \text{diag}((\pm 1)^m m!, (\pm 1)^{m-1} (m-1)!, \dots, (\pm 1)^n n!).$$

(1) For k odd, we have

$$B_k = \frac{1}{k!} D_{k-1, k'+1}^- \Delta_{k'} \left(\frac{\mathcal{B}_{i+j}}{(i+j)!} \right)_{1 \leq i, j \leq k'} \Delta_{k'} D_{k-1, k'+1}^+$$

and by (4.11), one obtains

$$\det B_k = \frac{k!}{2^{k'(k'+1)} (k!)^{k'}} \prod_{a=1}^{k'} \left[\frac{(k'+a)!}{(2a+1)!!} \right]^2 = \left[k! \prod_{a=1}^{k'} \binom{k}{a} \right]^{-1}.$$

For $4 \mid (k+2)$, we have

$$B_k = \frac{1}{k!} D_{k-1, k'+2}^- \Delta_{k'} \left(\frac{\mathcal{B}_{i+j+1}}{(i+j+1)!} \right)_{1 \leq i, j \leq k'} \Delta_{k'} D_{k-1, k'+2}^+$$

and

$$\det B_k = \frac{1}{2^{k'(k'+2)} (k!)^{k'}} \prod_{a=1}^{k'} \left[\frac{(k'+1+a)!}{(2a+1)!!} \right]^2 = \left[k!(k'+1) \prod_{a=2}^{k'} \binom{k}{a} \right]^{-1}$$

by (4.12).

For $4 \mid k$, we have

$$B_k = \frac{1}{k!} D_{k-2, k'+1}^- \Delta_{k'} \left(\frac{\mathcal{B}_{i+j}}{(i+j)!} \right)_{1 \leq i, j \leq k'} \Delta_{k'} D_{k-1, k'+2}^+$$

and

$$\det B_k = \frac{(k-1)!(k-1)!!}{2^{k'(k'+1)} (k!)^{k'} (k'+1)!} \prod_{a=1}^{k'} \left[\frac{(k'+a)!}{(2a+1)!!} \right]^2 = \left[k! \prod_{a=2}^{k'} \binom{k}{a} \right]^{-1}.$$

(2) We have

$$B'_k = \frac{1}{k!} D_{k-2, k'+2}^- \Delta_{k'-1} \left(\frac{\mathcal{B}_{i+j+1}}{(i+j+1)!} \right)_{1 \leq i, j \leq k'-1} \Delta_{k'-1} D_{k-2, k'+2}^+$$

and

$$\det B'_k = \frac{1}{2^{k'^2-1} (k!)^{k'-1}} \prod_{a=1}^{k'-1} \left[\frac{(k'+1+a)!}{(2a+1)!!} \right]^2 = \left[\frac{k}{4} (k')^2 \prod_{a=2}^{k'} \binom{k}{a} \right]^{-1}. \quad \square$$

5. Quadratic relations between periods and Bessel moments

In this section, we express the period pairing between rapid decay homology and de Rham cohomology of $\text{Sym}^k \text{Kl}_2$ in terms of Bessel moments and we obtain quadratic relations between them by specializing to our setting the general results from [Fresán et al. 2023].

5.1. Quadratic relations between periods. We use the topological pairing $\langle \cdot, \cdot \rangle_{\text{top}}$ on Kl_2 , which is compatible with the \mathbb{Q} -structure of Kl_2^∇ from Section 2.3. Recall that the induced pairing $\langle \cdot, \cdot \rangle_{\text{top}}$ on $\text{Sym}^k \text{Kl}_2$ is $(-1)^k$ -symmetric. The period pairing $P_1^{\text{rd,mod}}$ was defined in [Fresán et al. 2023], where the index 1 referred to the degree of rapid decay homology and moderate growth de Rham cohomology. Here we denote it by $P_k^{\text{rd,mod}}$, in order to emphasize that we are dealing with the k -th symmetric power and since there are no other nontrivial (co)homological degrees at play. Recall the de Rham cohomology classes ω_i from (3.2) and the rapid decay cycles α_i from (4.4). Since $(\alpha_i)_{0 \leq i \leq k'}$ is a basis of $H_1^{\text{rd}}(\mathbb{G}_m, \text{Sym}^k \text{Kl}_2)$ by Theorem 4.7(1) and $(\omega_i)_{0 \leq i \leq k'}$ is a basis of $H_{\text{dR}}^1(\mathbb{G}_m, \text{Sym}^k \text{Kl}_2)$ by [Fresán et al. 2022, Proposition 4.14], we deduce from the perfectness of the pairing $P_k^{\text{rd,mod}}$ (see [Fresán et al. 2023, Corollary 2.11]) that the $(k' + 1) \times (k' + 1)$ period matrix $(P_{k;i,j}^{\text{rd,mod}})_{0 \leq i,j \leq k'}$ defined by

$$P_{k;i,j}^{\text{rd,mod}} = P_k^{\text{rd,mod}}(\alpha_i, \omega_j)$$

is invertible. Thanks to the identity (2.16) relating v_0 to e_0 and the change of variables $t = 2\sqrt{z}$, the first row of this matrix reads

$$P_k^{\text{rd,mod}}(\alpha_0, \omega_j) = \int_{c_0} \langle e_0^k, v_0^k \rangle_{\text{top}} z^j \frac{dz}{z} = \int_{c_0} (2\pi i)^k I_0(2\sqrt{z})^k z^j \frac{dz}{z} = (2\pi i)^{k+1} \delta_{0,j}, \tag{5.1}$$

from which we immediately derive:

Proposition 5.2. *The $k' \times k'$ period matrix $P_k = (P_{k;i,j}^{\text{rd,mod}})_{1 \leq i,j \leq k'}$ is invertible.* □

The pure part of the pairing $P_k^{\text{rd,mod}}$ arises from the pairing between middle homology and middle de Rham cohomology. According to (4.5) and Theorem 4.7(3), the elements $(\alpha_i)_{i \in \llbracket 1, k' \rrbracket}$ map to a basis of $H_1^{\text{mid}}(\mathbb{G}_m, \text{Sym}^k \text{Kl}_2)$ whenever $4 \nmid k$. If $4 \mid k$, we instead consider the images of the shifted elements $(\alpha'_i)_{i \in \llbracket 1, k' \rrbracket}$, as introduced in Notation 4.8. Regarding $H_{\text{dR,mid}}^1(\mathbb{G}_m, \text{Sym}^k \text{Kl}_2)$, Corollary 3.11 gives the basis $(\omega_i)_{i \in \llbracket 1, k' \rrbracket}$ (resp. $(\omega'_i)_{i \in \llbracket 1, k' \rrbracket}$) if $4 \nmid k$ (resp. if $4 \mid k$), where ω'_i is modified as in (3.9). With this notation, the *middle period matrix* is defined as follows:

$$P_k^{\text{mid}} = (P_{k;i,j}^{\text{mid}})_{i,j \in \llbracket 1, k' \rrbracket} = \begin{cases} (P_k^{\text{rd,mod}}(\alpha_i, \omega_j))_{i,j \in \llbracket 1, k' \rrbracket} & \text{if } 4 \nmid k, \\ (P_k^{\text{rd,mod}}(\alpha'_i, \omega'_j))_{i,j \in \llbracket 1, k' \rrbracket} & \text{if } 4 \mid k. \end{cases}$$

In particular, $P_k^{\text{mid}} = P_k$ if $4 \nmid k$.

Recall the matrices S_k^{mid} from Section 3.2 and B_k^{mid} from Notation 4.8. In the current setting, the general method to express middle quadratic relations explained in [Fresán et al. 2023, Section 3.f], namely (3.21) therein yields the following result:

Theorem 5.3 (middle quadratic relations for $\text{Sym}^k \text{Kl}_2$). *The middle periods of $\text{Sym}^k \text{Kl}_2$ satisfy the following quadratic relations:*

$$(-2\pi i)^{k+1} B_k^{\text{mid}} = P_k^{\text{mid}} \cdot (S_k^{\text{mid}})^{-1} \cdot {}^t P_k^{\text{mid}}.$$

In particular, the matrix P_k^{mid} is invertible. □

5.2. Bessel moments as periods. We consider the power moments of the modified Bessel functions I_0 and K_0 defined by

$$\text{BM}_k(i, j) = (-1)^{k-i} 2^{k-j} (\pi i)^i \int_0^\infty I_0(t)^i K_0(t)^{k-i} t^j dt,$$

where the indices i and j are subject to the constraints

$$0 \leq i \leq k' \text{ and } j \geq 0 \quad \text{or, if } k \text{ is even, } i = \frac{k}{2} \text{ and } 0 \leq j \leq k' - 1.$$

For this range of indices, it results from the asymptotic expansion at infinity (2.14) that the improper integral $\text{BM}_k(i, j)$ converges. In what follows, such moments will occur only for odd j .

Proposition 5.4. *For all $1 \leq i, j \leq k'$, the following equality holds:*

$$P_{k;i,j}^{\text{rd,mod}} = \text{BM}_k(i, 2j - 1).$$

Proof. In view of the definition (4.4) of the twisted cycles α_i , we need to compute the integrals along c_0^a of $\langle e_0^{a-1} e_1^{k-a+1}, v_0^k \rangle_{\text{top}} z^j dz/z$ for $a = 1, \dots, k - i + 1$ and the integral along c_+ of $\langle e_0^i e_1^{k-i}, v_0^k \rangle_{\text{top}} z^j dz/z$.

Let us first remark that, for $\varepsilon \in (0, 1]$, we can replace c_0 and c_+ with the scalings $c_{0,\varepsilon}$ and $c_{+,\varepsilon}$ by ε defined with the base point ε instead of 1, leading to a twisted cycle $\alpha_{i,\varepsilon}$ equivalent to α_i ($1 \leq i \leq k'$). We will show

$$\lim_{\varepsilon \rightarrow 0} \int_{c_{0,\varepsilon}^a} \langle e_0^{a-1} e_1^{k-a+1}, v_0^k \rangle_{\text{top}} z^j \frac{dz}{z} = 0, \quad a = 1, \dots, k - i + 1, \tag{5.5}$$

$$\lim_{\varepsilon \rightarrow 0} \int_{c_{+,\varepsilon}} \langle e_0^i e_1^{k-i}, v_0^k \rangle_{\text{top}} z^j \frac{dz}{z} = \text{BM}_k(i, 2j - 1) \quad \text{for } 1 \leq i, j \leq k'. \tag{5.6}$$

We first show that the limits (5.5) are zero. According to (2.18), we only need to compute the coefficient of v_0^k in $e_0^{k-a+1} e_1^{a-1}$, which is equal to $I_0^{a-1} K_0^{k-a+1}$ up to a constant (see (2.16)). It remains to check that

$$\int_{\arg t=0}^{a\pi i} I_0(t)^{a-1} K_0(t)^{k-a+1} t^{2j-1} dt \rightarrow 0 \quad \text{when } |t| = 2\sqrt{\varepsilon} \text{ and } \varepsilon \rightarrow 0.$$

We can use the estimate (2.13) to compute the integral, and the assumption $j \geq 1$ implies that the absolute value of the integral tends to zero with ε .

For (5.6), recall that the coefficient of v_0^k in $e_0^{k-i} e_1^i$ is equal to $2^k (\pi i)^i \binom{k}{i} I_0^i K_0^{k-i}$, and thus (see (2.18))

$$\langle e_0^i e_1^{k-i}, v_0^k \rangle_{\text{top}} = (-1)^{k-i} \binom{k}{i}^{-1} 2^k (\pi i)^i \binom{k}{i} I_0^i K_0^{k-i} = (-1)^{k-i} 2^k (\pi i)^i I_0^i K_0^{k-i}.$$

The assertion (5.6) then follows from the relation $z^j dz/z = 2^{-2j+1} t^{2j-1} dt$. □

Corollary 5.7. *The matrix P_k^{mid} satisfies, for $i, j \in \llbracket 1, k' \rrbracket$,*

$$P_{k;i,j}^{\text{mid}} = \begin{cases} \text{BM}_k(i, 2j - 1) & \text{if } 4 \nmid k, \\ \text{BM}_k(i + 1, 2j - 1) - \gamma_{k,j} \text{BM}_k(i + 1, k') & \text{if } 4 \mid k \text{ and } i < k/4, \\ \text{BM}_k(i, 2j - 1) - \gamma_{k,j} \text{BM}_k(i, k') & \text{if } 4 \mid k \text{ and } i > k/4. \end{cases}$$

Example 5.8. Consider the case $k = 8$. Taking the determinant of the quadratic relations from [Theorem 5.3](#) and using the computation [\(3.23\)](#) and [Proposition 4.9\(2\)](#) yield

$$(\det P_8^{\text{mid}})^2 = (2\pi i)^{18} \det B_8^{\text{mid}} \det S_8^{\text{mid}} = \frac{-5^2 \pi^{18}}{2^4 3^2}.$$

On the other hand, by [Corollary 5.7](#) and the equalities $\gamma_{8,1} = 0$ and $\gamma_{8,3} = \frac{1}{8}$ from [\(3.6\)](#), we explicitly have

$$P_8^{\text{mid}} = \begin{pmatrix} (\pi i)^2 & \\ & -(\pi i)^3 \end{pmatrix} A \begin{pmatrix} 2^7 & \\ & 2^2 \end{pmatrix},$$

with

$$A = \int_0^\infty \begin{pmatrix} I_0(t)^2 K_0(t)^6 t & 2I_0(t)^2 K_0(t)^6 t^5 - I_0(t)^2 K_0(t)^6 t^3 \\ I_0(t)^3 K_0(t)^5 t & 2I_0(t)^3 K_0(t)^5 t^5 - I_0(t)^3 K_0(t)^5 t^3 \end{pmatrix} dt.$$

One can check numerically that $\det A$ is positive, and hence $\det A = 5\pi^4 / (2^{11} \cdot 3)$. Using the linear relations $BM_8^c(1, r) + BM_8^c(3, r) = 0$ from [Corollary 6.12](#) below for $r = 1, 5$, this verifies the numerical evaluation made in [\[Broadhurst and Roberts 2018, \(2.5\)\]](#).

5.3. Relation to the conjecture of Broadhurst and Roberts. Broadhurst and Roberts [\[2018, Section 5\]](#) use different normalizations to state their conjectural quadratic relations. Instead of the above matrices B_k and P_k , they consider matrices that we shall denote by B_k^{BR} and P_k^{BR} (the notation B_N and F_N is used in [\[loc. cit.\]](#), the index k being occupied by what is k' here). To compare their matrices with ours, we introduce auxiliary square matrices

$$U_{k'} = \text{antidiag}(1, \dots, 1), \quad R_{k'} = \text{antidiag}(i, i^2, \dots, i^{k'}), \quad T_{k'} = \text{diag}(-4, (-4)^2, \dots, (-4)^{k'})$$

of size k' , where the antidiagonal entries are listed down from the top corner. By [Propositions 4.6](#) and [5.4](#), the matrices B_k^{BR} and P_k^{BR} relate to ours as

$$U_{k'} B_k^{\text{BR}} U_{k'} = \frac{k!}{2^{k+1}} (i^{(k+i+j-1)} \cdot B_{k;i,j})_{1 \leq i, j \leq k'} \quad \text{and} \quad U_{k'} P_k^{\text{BR}} = \frac{1}{(-2\sqrt{\pi})^{k+1}} \cdot ((-4)^j i^j P_{k;i,j}^{\text{rd,mod}})_{1 \leq i, j \leq k'},$$

whence the identities

$$B_k^{\text{BR}} = -\frac{i^{(k+1)} k!}{2^{k+1}} {}^t R_{k'} \cdot B_k \cdot R_{k'} \quad \text{and} \quad P_k^{\text{BR}} = \frac{1}{(-2\sqrt{\pi})^{k+1}} {}^t R_{k'} \cdot P_k \cdot T_{k'}. \tag{5.9}$$

Besides, Broadhurst and Roberts [\[2018, page 7\]](#) define matrices $D_k^{\text{BR}} = (D_{k;i,j}^{\text{BR}})_{1 \leq i, j \leq k'}$ with rational coefficients and conjecture that, for all integers $k \geq 1$, the quadratic relation

$$P_k^{\text{BR}} \cdot D_k^{\text{BR}} \cdot {}^t P_k^{\text{BR}} = B_k^{\text{BR}}.$$

holds. In the direction of this conjecture, we obtain:

Corollary 5.10. *If $4 \nmid k$, then the matrix D_k defined as*

$$D_k = (-1)^k k! (T_{k'} \cdot S_k^{\text{mid}} \cdot T_{k'})^{-1}$$

satisfies

$$P_k^{\text{BR}} \cdot D_k \cdot {}^t P_k^{\text{BR}} = B_k^{\text{BR}}.$$

Proof. Under the assumption on k , we have $P_k = P_k^{\text{mid}}$ and $B_k = B_k^{\text{mid}}$. The statement then follows from the quadratic relations of [Theorem 5.3](#) and the equalities (5.9). \square

If $4 \mid k$, we set

$$B_k^{\text{BR}} = -\frac{i^{-(k+1)}k!}{2^{k+1}} R'_{k'} \cdot B_k^{\text{mid}} \cdot R'_{k'} \quad \text{and} \quad P_k^{\text{BR}} = \frac{1}{(-2\sqrt{\pi})^{k+1}} R'_{k'} \cdot P_k^{\text{mid}} \cdot T'_{k'},$$

where we denote by $R'_{k'}$ (resp. $T'_{k'}$) the matrix obtained from $R_{k'}$ (resp. $T_{k'}$) by deleting the row and the column of index $k/4$, that we consider as indexed by $[[1, k']^2]$. We define the matrix D'_k indexed by $[[1, k']^2]$ so that it satisfies the relation (see (3.16))

$$D'_k = (-1)^k k! (T'_{k'} \cdot S_k^{\text{mid}} \cdot T'_{k'})^{-1}.$$

Corollary 5.11. *If $4 \mid k$, then the matrix D'_k satisfies*

$$P_k^{\text{BR}} \cdot D'_k \cdot {}^t P_k^{\text{BR}} = B_k^{\text{BR}}.$$

Remark 5.12. Numerical computations show that, for all integers $k \leq 22$ that are not multiples of 4, the equality $D_k = D_k^{\text{BR}}$ holds. On the other hand, for $k = 8, 12, 16, 20$, the matrix D'_k coincides with the matrix D_k^{BR} obtained from D_k^{BR} by deleting the row and the column of index $k/4$. These computations also seem to suggest that $k!(S_k^{\text{mid}})^{-1}$ has integral coefficients. Is it true for all k ?

6. The full period matrices

In [Theorem 5.3](#), we emphasized quadratic relations for the middle periods to make the link with the conjecture of Broadhurst and Roberts. However, quadratic relations hold between the rapid-decay versus moderate periods

$$P_k^{\text{rd,mod}} : H_1^{\text{rd}}(\mathbb{G}_m, \text{Sym}^k \text{Kl}_2) \otimes H_{\text{dR}}^1(\mathbb{G}_m, \text{Sym}^k \text{Kl}_2) \rightarrow \mathbb{C}$$

and the moderate versus rapid-decay periods

$$P_k^{\text{mod,rd}} : H_1^{\text{mod}}(\mathbb{G}_m, \text{Sym}^k \text{Kl}_2) \otimes H_{\text{dR,c}}^1(\mathbb{G}_m, \text{Sym}^k \text{Kl}_2) \rightarrow \mathbb{C}.$$

Namely, it follows from [\[Fresán et al. 2023, Remark 2.15\]](#) that

$$(-2\pi i)^{k+1} B_k^{\text{rd,mod}} = P_k^{\text{rd,mod}} \cdot (S_k)^{-1} \cdot {}^t P_k^{\text{mod,rd}},$$

where $B_k^{\text{rd,mod}}$ and S_k stand for the complete Betti and de Rham intersection pairings. In this section, we consider the bases $\mathcal{B}_{k,c}$, \mathcal{B}_k and $(\alpha_i)_i$, $(\beta_i)_i$ as defined in [Section 3.1](#) and [Theorem 4.7](#), and we compute the entries of the matrices of $P_k^{\text{rd,mod}}$ and $P_k^{\text{mod,rd}}$ which do not appear in P_k^{mid} .

6.1. The complete period matrix $\mathbf{P}^{\text{rd,mod}}$. In order to finish the computation of the complete period matrix $(\mathbf{P}_{k;i,j}^{\text{rd,mod}})_{0 \leq i, j \leq k'}$, we are left, according to (5.1) and Proposition 5.4, with computing the terms $\mathbf{P}_{k;i,0}^{\text{rd,mod}}$ for $i = 1, \dots, k'$. In such a range, we consider regularized Bessel moments defined as follows, according to the expansions (2.13) and (2.14).

Definition 6.1 (regularized Bessel moments). For all i such that $0 \leq i \leq k'$, the functions

$$G_{k,i}(\varepsilon) = \int_{\varepsilon}^{\infty} I_0(t)^i K_0(t)^{k-i} \frac{dt}{t} + \frac{(-1)^{k-i}}{k-i+1} (\gamma + \log(\varepsilon/2))^{k-i+1}$$

are holomorphic on small sectors containing $\varepsilon \in \mathbb{R}_{>0}$ and have finite limit as $\varepsilon \rightarrow 0^+$. The regularized Bessel moments are defined as

$$\text{BM}_k^{\text{reg}}(i, -1) = (-1)^{k-i} 2^{k+1} (\pi i)^i \lim_{\varepsilon \rightarrow 0^+} G_{k,i}(\varepsilon).$$

Proposition 6.2. *We have*

$$\mathbf{P}_k^{\text{rd,mod}}(\alpha_i, \omega_0) = \text{BM}_k^{\text{reg}}(i, -1), \quad \text{for } 1 \leq i \leq k'.$$

Proof. We argue as for (5.5) and (5.6). If $1 \leq i \leq k'$, let

$$\mathbf{P}'_k(\alpha_i, \omega_0) = \mathbf{P}_k^{\text{rd,mod}}\left(\alpha_i + \frac{(-1)^{k-i} (k-i)!}{k-i+2} \alpha_0, \omega_0\right),$$

so that

$$\mathbf{P}_k^{\text{rd,mod}}(\alpha_i, \omega_0) = \mathbf{P}'_k(\alpha_i, \omega_0) - \frac{(-1)^{k-i} (k-i)!}{k-i+2} \mathbf{P}_k^{\text{rd,mod}}(\alpha_0, \omega_0). \tag{6.3}$$

On the one hand, by scaling the chains c_+ and c_0 by $\varepsilon \in \mathbb{R}_{>0}$ and letting $\varepsilon' = 2\sqrt{\varepsilon}$, we find

$$\begin{aligned} \mathbf{P}'_k(\alpha_i, \omega_0) &= \int_{c_{+,\varepsilon}} \langle e_0^i e_1^{k-i}, v_0^k \rangle_{\text{top}} \frac{dz}{z} + \sum_{a=1}^{k-i+1} C_{k-i+1}(a) \int_{c_{0,\varepsilon}^a} \langle e_0^{i-1} e_1^{k-i+1}, v_0^k \rangle_{\text{top}} \frac{dz}{z} \\ &= (-1)^{k-i} 2^k (\pi i)^i \int_{\varepsilon}^{\infty} I_0(2\sqrt{z})^i K_0(2\sqrt{z})^{k-i} \frac{dz}{z} \\ &\quad + (-1)^{k-i+1} 2^k (\pi i)^{i-1} \sum_{a=1}^{k-i+1} C_{k-i+1}(a) \int_{c_{0,\varepsilon}^a} I_0(2\sqrt{z})^{i-1} K_0(2\sqrt{z})^{k-i+1} \frac{dz}{z} \\ &= (-1)^{k-i} 2^{k+1} (\pi i)^i \int_{\varepsilon'}^{\infty} I_0(t)^i K_0(t)^{k-i} \frac{dt}{t} \\ &\quad + (-1)^{k-i+1} 2^{k+1} (\pi i)^{i-1} \sum_{a=1}^{k-i+1} C_{k-i+1}(a) \int_{c_{0,\varepsilon'}^a} I_0(t)^{i-1} K_0(t)^{k-i+1} \frac{dt}{t} \\ &= (-1)^{k-i} 2^{k+1} (\pi i)^i \int_{\varepsilon'}^{\infty} I_0(t)^i K_0(t)^{k-i} \frac{dt}{t} \\ &\quad + 2^{k+1} (\pi i)^{i-1} \sum_{a=1}^{k-i+1} C_{k-i+1}(a) \int_{c_{0,\varepsilon'}^a} [(\gamma + \log(t/2))^{k-i+1} + O(t^2 \log^{k-i+1} t)] \frac{dt}{t}. \end{aligned}$$

Lemma 4.1 yields

$$\begin{aligned} \sum_{a=1}^{k-i+1} C_{k-i+1}(a) \int_{c_{0,\varepsilon'}^{a/2}} (\gamma + \log(t/2))^{k-i+1} \frac{dt}{t} \\ = \frac{1}{k-i+2} \sum_{a=1}^{k-i+1} C_{k-i+1}(a) [(\gamma + \log(\varepsilon'/2) + \pi i a)^{k-i+2} - (\gamma + \log(\varepsilon'/2))^{k-i+2}] \\ = \frac{\pi i}{k-i+1} (\gamma + \log(\varepsilon'/2))^{k-i+1} + \frac{(-1)^{k-i} (k-i)!}{k-i+2} (\pi i)^{k-i+2}. \end{aligned}$$

Letting $\varepsilon \rightarrow 0^+$, one obtains

$$P'_k(\alpha_i, \omega_0) = \text{BM}_k^{\text{reg}}(i, -1) + \frac{(-1)^{k-i} (k-i)!}{k-i+2} (2\pi i)^{k+1}.$$

On the other hand, $P_k^{\text{rd,mod}}(\alpha_0, \omega_0) = (2\pi i)^{k+1}$ as computed in (5.1), and (6.3) gives the desired formula. □

6.2. The complete period matrix $P_k^{\text{mod,rd}}$. The period matrix $P_k^{\text{mod,rd}}$ is defined by

$$P_{k;i,j}^{\text{mod,rd}} = P_k^{\text{mod,rd}}(\beta_i, (\widehat{m}_j, \omega'_j)), \quad \begin{cases} 0 \leq i, j \leq k' & \text{if } 4 \nmid k, \\ \begin{cases} 0 \leq i \leq k/2, i \neq 1 \\ 0 \leq j \leq k' \end{cases} & \text{if } 4 \mid k, \end{cases}$$

(see the notation of (3.9) for ω'_j) and is nondegenerate (argument similar to that for $P_k^{\text{rd,mod}}$). According to [Fresán et al. 2023, Section 3.f], its middle part is equal to P_k^{mid} already computed:

- If $4 \nmid k$, we are left with computing $P_{k;i,j}^{\text{mod,rd}}$ for $i, j \in [0, k']$ and i or $j = 0$.
- If $4 \mid k$, we are left with computing $P_{k;i,j}^{\text{mod,rd}}$ with

$$\begin{cases} i = 0, 2, \dots, k/2, j = 0, k/4, \\ i = 0, k/2, j = 1, \dots, k', j \neq k/4. \end{cases}$$

Definition 6.4 (regularized Bessel moments, continued). If $4 \mid k$ and $k/4 < j \leq k'$, the function $\varepsilon \mapsto H_{k,j}(\varepsilon)$ defined by (see (3.5))

$$H_{k,j}(\varepsilon) = \int_0^{1/\varepsilon} (I_0(t)K_0(t))^{k/2} \left(t^{2j} - \frac{\gamma_{k,j}}{2^{k/2-2j}} t^{k/2} \right) \frac{dt}{t} - \frac{1}{2^{k-2j+1}} \sum_{n=1}^j \frac{\gamma_{k,j-n}}{n(4\varepsilon^2)^n}$$

is holomorphic near $\mathbb{R}_{>0}$ with finite limit when $\varepsilon \rightarrow 0^+$. We set

$$\text{BM}_k^{\text{reg}}(k/2, 2j-1) = 2^{k-2j+1} (\pi i)^{k/2} \lim_{\varepsilon \rightarrow 0^+} H_{k,j}(\varepsilon).$$

Proposition 6.5. (1) If $4 \nmid k$, we have:

- (a) $P_{k;i,0}^{\text{mod,rd}} = (-1)^k \delta_{i,0}, i = 0, \dots, k'$.
- (b) $P_{k;0,j}^{\text{mod,rd}} = \text{BM}_k(0, 2j-1), j = 1, \dots, k'$.

(2) If $4 \mid k$, we have:

- (a) $P_{k;i,0}^{\text{mod,rd}} = \delta_{i,0}, i = 0, \dots, k/2.$
- (b) $P_{k;i,k/4}^{\text{mod,rd}} = -(2\pi i)^{k/2} 2^{k/2} \binom{k}{k/2}^{-1} \delta_{i,k/2}, i = 0, \dots, k/2.$
- (c) $P_{k;0,j}^{\text{mod,rd}} = \text{BM}_k(0, 2j - 1) - \gamma_{k,j} \text{BM}_k(0, k'), j = 1, \dots, k', j \neq k/4.$
- (d) $P_{k;k/2,j}^{\text{mod,rd}} = \begin{cases} \text{BM}_k(k/2, 2j - 1) & 1 \leq j < k/4, \\ \text{BM}_k^{\text{reg}}(k/2, 2j - 1) & k/4 < j \leq k'. \end{cases}$

Proof. For (a) and (a), we note that

$$P_k^{\text{mod,rd}}(\beta_i, (\widehat{m}_0, 0)) = \langle e_0^i e_1^{k-i}, e_0^k \rangle_{\text{top}} = (-1)^k \delta_{i,0}.$$

Similarly, for (b) (see Proposition 3.8 and [Fresán et al. 2023, Proposition 3.18]),

$$P_k^{\text{mod,rd}}(\beta_i, (\widehat{m}_{k/4}, 0)) = -\langle e_0^i e_1^{k-i}, 2^k (\pi i)^{k/2} (e_0 e_1)^{k/2} \rangle_{\text{top}} = -2^k (\pi i)^{k/2} \binom{k}{k/2}^{-1} \delta_{i,k/2}.$$

For the rest, since the coefficients of the cycle β_i in terms of $\{u_a\}$, have logarithmic growth at 0, and $\widehat{m}_{j,0}$ is holomorphic and vanishes (Lemma 3.3), the contribution $\lim_{z \rightarrow 0} \langle e_0^i e_1^{k-i}, \widehat{m}_{j,0} \rangle_{\text{top}}(z)$ of $\langle \beta_i, \widehat{m}_{j,0} \rangle_{\text{top}}$ in [Fresán et al. 2023, Proposition 3.18] in the period pairing is zero. For $i \neq k/2$ or $i = k/2, 1 \leq j < k/4$, the coefficient $(-1)^{k-i} (\pi i)^i \xi_{j,i}$ of $\langle \beta_i, \widehat{m}_{j,\infty} \rangle_{\text{top}}$ (see (3.13)) is holomorphic near $\mathbb{R}_{>0}$ and vanishes at ∞ , so the contribution of $\widehat{m}_{j,\infty}$ is zero too. In this case, one therefore has

$$P_k^{\text{mod,rd}}(\beta_i, (\widehat{m}_j, \omega'_j)_{\text{top}}) = \int_{\mathbb{R}_+} \langle e_0^i e_1^{k-i}, \omega'_j \rangle_{\text{top}} = \text{BM}_k(i, 2j - 1) - \gamma_{k,j} \text{BM}_k(i, k')$$

as in the proof of Proposition 5.4. This completes the cases (b), (c) and the first part of (d).

It remains to check the second part of (d), with $k/4 < j \leq k'$. Let

$$\xi = (-4\pi i I_0 K_0)^{k/2} z^{j-1} dz \quad \text{and} \quad \eta = (-4\pi i I_0 K_0)^{k/2} z^{k/4-1} dz.$$

We have

$$\langle (e_0 e_1)^{k/2}, \omega'_j \rangle_{\text{top}} = \langle (e_0 e_1)^{k/2}, (\omega_j + \text{res}_{z=\infty}(\omega_j) \omega_{k/4}) \rangle_{\text{top}} = \xi + \text{res}_{z=\infty}(\xi) \eta.$$

Note that $\widehat{m}_{j,\infty}$ is defined so that $d\langle (e_0 e_1)^{k/2}, \widehat{m}_{j,\infty} \rangle_{\text{top}} = \xi + \text{res}_{z=\infty}(\xi) \eta$ and $\langle (e_0 e_1)^{k/2}, \widehat{m}_{j,\infty} \rangle_{\text{top}}$ has no constant term in the fractional Laurent series expansion in $1/z$. We then obtain

$$P_k^{\text{mod,rd}}(\alpha_{k/2}, (\widehat{m}_j, \omega'_j)) = \lim_{\tau \rightarrow \infty} \int_0^\tau \xi + \text{res}_{z=\infty}(\xi) \eta - \langle (e_0 e_1)^{k/2}, \widehat{m}_{j,\infty} \rangle_{\text{top}}(\tau) = \text{BM}_k^{\text{reg}}(k/2, 2j - 1). \quad \square$$

Example 6.6. Respectively for $k = 3, 4$, the complete quadratic relations lead to the equalities of the regularized Bessel moments

$$\begin{aligned} \lim_{\varepsilon \rightarrow 0^+} \int_\varepsilon^\infty I_0(t) K_0(t)^2 \frac{dt}{t} + \frac{1}{3} (\gamma + \log \varepsilon/2)^3 &= \frac{3}{2} \int_0^\infty K_0(t)^3 t \, dt \cdot \int_0^\infty I_0(t) K_0(t)^2 t \, dt, \\ \lim_{\varepsilon \rightarrow 0^+} \int_\varepsilon^\infty I_0(t) K_0(t)^3 \frac{dt}{t} - \frac{1}{4} (\gamma + \log \varepsilon/2)^4 &= \frac{\pi^4}{120}. \end{aligned}$$

Remark 6.7 (determinant of P_k). A formula for the determinant of the matrix P_k in Proposition 5.2, which implies in particular its nonvanishing, was conjectured by Broadhurst and Mellit [2016] and Broadhurst [2016, Conjecture 4 and 7] and proved by Zhou [2018b]. Since $\det S_k$ is computed in Remark 3.22 and the determinant of the Betti intersection matrix is computed in Proposition 4.9 in order to prove its nonvanishing, the quadratic relations also lead to a computation of $\det P_k$ up to sign.

Remark 6.8 (dimension of the linear span of Bessel moments). Zhou [2019b, Theorem 1.2], shows that, for each i such that $1 \leq i \leq k'$ (resp. for $i = 0$), the \mathbb{Q} -vector space E_i spanned by the Bessel moments $\text{BM}_k(i, 2j - 1)$ for all $j \geq 1$ has dimension at most k' (resp. at most $k' + 1$). From the point of view of the present paper, the upper bound $\dim_{\mathbb{Q}} E_i \leq k'$ when $1 \leq i \leq k'$ is a direct consequence of the fact that the $\text{BM}_k(i, 2j - 1)$ result from pairing the fixed rapid decay cycle α_i with the de Rham cohomology classes $\omega_j = [z^j u_0 dz/z]$. Provided $j \geq 1$ and k is not a multiple of 4, all these ω_j lie in the middle de Rham cohomology $H_{\text{dR}, \text{mid}}^1(\mathbb{G}_m, \text{Sym}^k \text{Kl}_2)$, which has dimension k' . If k is a multiple of 4, the periods $P_k^{\text{mid}}(\alpha_i, \cdot)$ are generated by $\text{BM}_k(i, 2j - 1) - \gamma_{k,j} \text{BM}_k(i, k')$ for $j \in [1, k']$, with $\gamma_{k,k/4} = 1$. For each $j \geq 1$, the class $(z^j - \gamma_{k,j} z^{k/4})u_0 dz/z$ lies in $H_{\text{dR}, \text{mid}}^1(\mathbb{G}_m, \text{Sym}^k \text{Kl}_2)$ and has period $\text{BM}_k(i, 2j - 1) - \gamma_{k,j} \text{BM}_k(i, k')$ when paired with α_i . Therefore, $\dim_{\mathbb{Q}} E_i \leq k'$ holds. In the case $i = 0$, the periods $P_k^{\text{mod}, \text{rd}}(\alpha_0, \cdot)$ are generated by

$$1 \quad \text{and} \quad \text{BM}_k(0, 2j - 1) - \gamma_{k,j} \text{BM}_k(0, k') \quad (1 \leq j \leq k').$$

Again, for each $j \geq 1$, there exists \widehat{m}_j such that the class

$$(\widehat{m}_j, (z^j - \gamma_{k,j} z^{k/4})u_0 dz/z)$$

lies in $H_{\text{dR}, \text{c}}^1(\mathbb{G}_m, \text{Sym}^k \text{Kl}_2)$ and has period

$$\text{BM}_k(0, 2j - 1) - \gamma_{k,j} \text{BM}_k(0, k')$$

when paired with α_0 . Hence, $\dim_{\mathbb{Q}} E_0 \leq k' + 1$, as this is the dimension of de Rham cohomology with compact support.

6.3. Linear relations. When k is even, there is a unique nontrivial linear relation among the $k' + 2$ classes $(\beta_j)_{0 \leq j \leq k/2}$ in $H_1^{\text{mod}}(\mathbb{G}_m, \text{Sym}^k \text{Kl}_2)$. We determine explicitly the moderate 2-chain that yields this relation.

Lemma 6.9. For two integers n, r with $0 \leq r \leq 2n$,

$$\sum_{i=0}^{\min\{n, 2n-r\}} (-1)^i \binom{n}{i} \binom{2n-i}{r} = \begin{cases} 0 & \text{if } 0 \leq r \leq n - 1, \\ \binom{n}{r-n} & \text{if } n \leq r \leq 2n. \end{cases}$$

Proof. We provide two approaches; the second one has been provided by Hao-Yun Yao of NTU.

Let a_r be the sum in the left hand side. Then the polynomial $f(x) = \sum_{r=0}^{2n} a_r x^r$ is the coefficient of y^n in the expansion of

$$g(x, y) = (y - 1)^n \sum_{r=0}^n (x + 1)^{2n-r} y^r = (x + 1)^n (y - 1)^n \sum_{j=0}^n (x + 1)^{n-j} y^j.$$

Thus one obtains

$$f(x) = (x + 1)^n ((x + 1) - 1)^n = x^n (x + 1)^n$$

and the assertion follows.

Alternatively, let S be the set of subsets of $\{1, 2, \dots, 2n\}$ consisting of r elements and define $T = \{A \in S \mid \{1, 2, \dots, n\} \subset A\}$. Members of T are obtained by choosing $(r - n)$ elements from $\{n + 1, \dots, 2n\}$ so that the cardinality $|T|$ equals 0 if $0 \leq r < n$ or $\binom{n}{r-n}$ if $n \leq r \leq 2n$. Let $S_c = \{A \in S \mid c \notin A\}$. One has $S = T \sqcup (S_1 \cup \dots \cup S_n)$ and $|S_{c_1} \cap \dots \cap S_{c_i}| = \binom{2n-i}{r}$ for $1 \leq c_1 < \dots < c_i \leq 2n$. The inclusion-exclusion principle then gives the formula. □

Proposition 6.10. *Let $\tilde{\mathbb{P}}^1$ be the real oriented blow-up of \mathbb{P}^1 along $\{0, \infty\}$ as in Section 2.3, and consider the simplicial 2-chain*

$$\rho : \{(x, y) \in \mathbb{R}^2 \mid 0 \leq x, y, x + y \leq 1\} \rightarrow \tilde{\mathbb{P}}^1, \quad \rho(x, y) = \tan \frac{\pi(x + y)}{2} \exp(4i \tan^{-1}(y/x)),$$

which covers $\tilde{\mathbb{P}}^1$ once. If k is even, the singular chain

$$\Delta = \rho \otimes \sum_{i=0}^{k/2} (-1)^i \binom{k/2}{i} e_0^i e_1^{k-i}$$

is of moderate growth, and the relation

$$\sum_{i=0}^{\lfloor (k-2)/4 \rfloor} \binom{k/2}{2i+1} \beta_{2i+1} = 0$$

holds in $H_1^{\text{mod}}(\mathbb{G}_m, \text{Sym}^k \text{Kl}_2)$.

Proof. It follows as direct consequences of the monodromy relation and Lemma 6.9, which also imply that

$$\frac{-1}{2} \partial \Delta = \sum_{i=0}^{\lfloor (k-2)/4 \rfloor} \binom{k/2}{2i+1} \beta_{2i+1}. \quad \square$$

If $4 \mid (k + 2)$, choosing the principal determination of $w^{1/2}$ near $\mathbb{R}_{>0}$, we write, in a way similar to (3.4), the asymptotic expansion

$$2^k (I_0(t) K_0(t))^{k/2} \sim w^{k/4} \sum_{n=0}^{\infty} \gamma'_{k, n+k/4} w^n.$$

As in Definition 6.4, one checks that, for $j \in [(k + 2)/4, k']$, the difference

$$H_{k,j}(\varepsilon) = \int_0^{1/\varepsilon} (I_0(t)K_0(t))^{k/2} t^{2j} \frac{dt}{t} - \frac{1}{2^{k-2j+1}\varepsilon} \sum_{n=0}^j \frac{\gamma'_{k,j-n-1/2}}{(2n+1)(4\varepsilon^2)^n}$$

is holomorphic near $\mathbb{R}_{>0}$ with finite limit as $\varepsilon \rightarrow 0$. Set

$$\text{BM}_k^{\text{reg}}(k/2, 2j - 1) = -2^{k-2j+1}(\pi i)^{k/2} \lim_{\sigma \rightarrow 0^+} H_{k,j}(\sigma).$$

In this case, one has

$$P_k^{\text{mod,rd}}(\beta_{k/2}, (\widehat{m}_j, \omega'_j)) = \begin{cases} 0 & \text{if } j = 0, \\ \text{BM}_k(k/2, 2j - 1) & \text{if } 1 \leq j \leq (k - 2)/4, \\ \text{BM}_k^{\text{reg}}(k/2, 2j - 1) & \text{if } (k + 2)/4 \leq j \leq k' \end{cases}$$

as in Proposition 6.5(2). To unify the situations, we introduce the compactly supported version of the Bessel moments.

Definition 6.11. Assume k is even. We set

$$\text{BM}_k^c(i, 2j - 1) = \begin{cases} \text{BM}_k^{\text{reg}}(k/2, 2j - 1) & \text{if } \begin{cases} i = k/2, \\ \lfloor k/4 \rfloor + 1 \leq j \leq k', \end{cases} \\ \text{BM}_k(i, 2j - 1) - \gamma_{k,j} \text{BM}_k(i, k') & \text{if } 4 \mid k, 0 \leq i \leq k', \\ \text{BM}_k(i, 2j - 1) & \text{otherwise.} \end{cases}$$

Corollary 6.12 (sum rule identities). Assume k is even and set $k'' = \lfloor (k - 1)/4 \rfloor$. The linear relations among Bessel moments

$$\sum_{i=0}^{k''} \binom{k/2}{2i+1} \text{BM}_k^c(2i + 1, 2j - 1) = 0 \tag{6.13}$$

hold for all j such that

$$\begin{cases} 1 \leq j \leq 2k'' & \text{if } 4 \mid (k + 2), \\ 1 \leq j \leq 2k'' + 1, j \neq k/4 & \text{if } 4 \mid k. \end{cases}$$

Remark 6.14. For $j \in [1, k']$, these *sum rule identities* were proved by Zhou by analytic means; see [Zhou 2019a, (1.3)] for $4 \mid (k + 2)$ and [loc. cit., (1.5)] for $4 \mid k$, where the second argument of the Bessel moments is also allowed to be even. Our proof, closer to the spirit of the Kontsevich–Zagier period conjecture, produces the relation (6.13) simply from the Stokes formula.

7. Comparison of period structures

In [Fresán et al. 2022], we have introduced the Nori motives M_k defined over \mathbb{Q} , whose definition we recall in Section 7.1, and we have explained how the Hodge filtration of their Hodge realization can be computed in terms of symmetric powers of the Kloosterman connection on \mathbb{G}_m and their irregular Hodge filtration. We aim at making Deligne’s conjecture on critical values explicit for them in Section 8. In this

section as a preparation, we focus on the comparisons of various \mathbb{Q} -structures. For that purpose, we only retain from each Nori motive M_k

- its *period realization* (over $\text{Spec } \mathbb{Q}$, see [Section A4](#)), that is, the \mathbb{Q} -vector spaces $(M_k)_{\text{dR}}$ (de Rham realization) and $(M_k)_{\text{B}}$ (Betti realization), together with the comparison isomorphism $\text{comp} : \mathbb{C} \otimes_{\mathbb{Q}} (M_k)_{\text{B}} \simeq \mathbb{C} \otimes_{\mathbb{Q}} (M_k)_{\text{dR}}$, and
- the action F_{∞} on $(M_k)_{\text{B}}$ induced by geometric complex conjugation.

On the other hand, the computations of the previous sections lead us to define a (transposed) period structure (over $\text{Spec } \mathbb{Q}$) as follows:

- The de Rham \mathbb{Q} -vector space $H_{\text{dR,mid}}^1(\mathbb{G}_m, \text{Sym}^k \text{Kl}_2)_{\mathbb{Q}}$ is the \mathbb{Q} -vector space generated by the family $\mathcal{B}_{k,\text{mid}}$ of [Corollary 3.11](#).
- The (dual) Betti \mathbb{Q} -vector space $H_1^{\text{mid}}(\mathbb{G}_m, \text{Sym}^k \text{Kl}_2)_{\mathbb{Q}}$ is the \mathbb{Q} -vector space generated by the family (β_j) of twisted cycles of [Theorem 4.7\(3\)](#).
- The period pairing is the pairing P_k^{mid} .

There is an obvious notion of morphism of period structures.

Theorem 7.1. *The period structure $((M_k)_{\text{dR}}, (M_k)_{\text{B}}, \text{comp})$ of the motive M_k is isomorphic to the transpose of $(H_{\text{dR,mid}}^1(\mathbb{G}_m, \text{Sym}^k \text{Kl}_2)_{\mathbb{Q}}, H_1^{\text{mid}}(\mathbb{G}_m, \text{Sym}^k \text{Kl}_2)_{\mathbb{Q}}, P_k^{\text{mid}})$.*

Furthermore, we will give an explicit description under this correspondence of the action F_{∞} on $H_1^{\text{mid}}(\mathbb{G}_m, \text{Sym}^k \text{Kl}_2)_{\mathbb{Q}}$.

We proceed in two steps. Firstly in [Section 7.1](#), in an analogous way to the method used in [\[Fresán et al. 2022\]](#), we realize the mixed Hodge structure corresponding to M_k together with its associated period structure as the exponential mixed Hodge structure and the associated period structure attached to a function on a smooth variety equipped with the action of a finite group. We also analyze the automorphism of the Betti fiber of this exponential mixed Hodge structure induced by the complex conjugation on the variety underlying M_k . In particular, we avoid computing periods directly on the variety underlying the motive M_k . The tools for this part are developed in the appendix in which the period realization of exponential mixed Hodge structures is investigated, extending the focus on the de Rham realization in the appendix of [\[loc. cit.\]](#). Then in [Section 7.2](#), we compare these objects to those of the previous sections by making explicit differential forms of higher degree and higher dimensional twisted cycles that correspond to the bases obtained for $\text{Sym}^k \text{Kl}_2$ there. The period matrix computed in [Proposition 5.4](#) is thus a period matrix for M_k , and the action of the conjugation is explicit since the Bessel moments we consider are either real or purely imaginary.

7.1. The motives M_k . Let $y = (y_1, \dots, y_k)$ be the Cartesian coordinates of the torus \mathbb{G}_m^k defined over \mathbb{Q} . Upon \mathbb{G}_m^k , consider the action of $\mathfrak{S}_k \times \mu_2$ where the symmetric group \mathfrak{S}_k acts by permuting the variables y and the group $\mu_2 = \{\pm 1\}$ acts as $y_i \mapsto \pm y_i$. Denote by $g_k : \mathbb{G}_m^k \rightarrow \mathbb{A}^1$ the regular function given by the

Laurent polynomial

$$g_k(y_1, \dots, y_k) = \sum_{i=1}^k \left(y_i + \frac{1}{y_i} \right)$$

and let $\mathcal{X}_0 = (g_k)$ be the associated closed subvariety of \mathbb{G}_m^k . Then \mathcal{X}_0 is invariant under the action of $\mathfrak{S}_k \times \mu_2$ and hence the latter acts on various cohomology spaces, or on the (Nori) motives $H^{k-1}(\mathcal{X}_0)$ and $H_c^{k-1}(\mathcal{X}_0)$ of degree $k - 1$ of \mathcal{X}_0 . Let $\text{sgn}: \mathfrak{S}_k \times \mu_2 \rightarrow \mathbb{Q}^\times$ be the product of the sign character on \mathfrak{S}_k and the trivial one on μ_2 . We define the pure motive M_k of weight $k + 1$ over \mathbb{Q} by taking the sgn -isotypic part

$$M_k = \text{gr}_{k+1}^W [H_c^{k-1}(\mathcal{X}_0)(-1)]^{\mathfrak{S}_k \times \mu_2, \text{sgn}},$$

where W indicates the weight filtration; see [Fresán et al. 2022, (3.1)]. The Betti realization $(M_k)_B$ and the de Rham realization $(M_k)_{\text{dR}}$ of M_k are the \mathbb{Q} -vector spaces of dimension $\lfloor (k - 1/2) \rfloor - \delta_{4\mathbb{Z}}(k)$ obtained by replacing H_c by the corresponding cohomology functors (with compact support).

Let \mathcal{X} be the complex variety defined by the base change of \mathcal{X}_0 to \mathbb{C} . It is shown in [loc. cit.] that the base change

$$\mathbb{C} \otimes (M_k)_{\text{dR}} = \text{gr}_{k+1}^W [H_{\text{dR},c}^{k-1}(\mathcal{X})(-1)]^{\mathfrak{S}_k \times \mu_2, \text{sgn}}$$

of the de Rham realization $(M_k)_{\text{dR}}$ is identified with $H_{\text{dR},\text{mid}}^1(\mathbb{G}_m, \text{Sym}^k \text{Kl}_2)$ discussed in the previous sections.

The pair (U, \tilde{f}_k) . We consider the torus $U_0 = \mathbb{G}_{m,t} \times \mathbb{G}_m^k$ over \mathbb{Q} with its \mathbb{C} -extension U , endowed with

- the action of \mathfrak{S}_k permuting the coordinates on \mathbb{G}_m^k ,
- the action of μ_2 sending (t, y) to $\pm(t, y)$,
- the involution ι sending t to t and y_i to $-y_i$ for each i ,
- the antilinear involution conj on the analytic manifold $U(\mathbb{C})$ induced by the conjugation of coordinates, which commutes with all the above actions.

Let $\tilde{f}_k: U_0 = \mathbb{G}_{m,t} \times \mathbb{G}_m^k \rightarrow \mathbb{A}^1$ denote the Laurent polynomial $(t/2) \cdot g_k$, where g_k is defined above. Then \tilde{f}_k is left invariant by the action of \mathfrak{S}_k , μ_2 and conj , and satisfies $\iota^* \tilde{f}_k = -\tilde{f}_k$.

Conjugation acts on $\Omega^p(U)$ by changing a p -form $\omega(t, y)$ to $\overline{\omega(\bar{t}, \bar{y})}$. Therefore, $\text{conj}^*(d\tilde{f}_k) = d\tilde{f}_k$ and conj^* induces an involution on $H_{\text{dR},c}^{k+1}(U, \tilde{f}_k)$, $H_{\text{dR}}^{k+1}(U, \tilde{f}_k)$ and $H_{\text{dR},\text{mid}}^{k+1}(U, \tilde{f}_k)$ which commutes with the action induced by $\mathfrak{S}_k \times \mu_2$ and ι^* .

According to [Fresán et al. 2022, Theorem 3.8], the associated mixed Hodge structure $(M_k)_H$ is identified with the exponential mixed Hodge structure $H_{\text{mid}}^{k+1}(U, \tilde{f}_k)^{\mathfrak{S}_k \times \mu_2, \text{sgn}}$. In particular, they have isomorphic period realizations; see the Appendix.

The de Rham realization $(M_k)_{\text{dR}}$. The pair (U, \tilde{f}_k) , together with the action of $\mathfrak{S}_k \times \mu_2$, is the \mathbb{C} -extension of the pair (U_0, \tilde{f}_k) defined over \mathbb{Q} . As explained in Section A4, the de Rham cohomologies $H_{\text{dR},?}^{k+1}(U, \tilde{f}_k)$ ($? = \emptyset, c, \text{mid}$) are also endowed with the \mathbb{Q} -structure $H_{\text{dR},?}^{k+1}(U_0, \tilde{f}_k)$, and therefore so are the sgn -isotypic components $H_{\text{dR},?}^{k+1}(U, \tilde{f}_k)^{\mathfrak{S}_k \times \mu_2, \text{sgn}}$ with the \mathbb{Q} -structure $H_{\text{dR},?}^{k+1}(U_0, \tilde{f}_k)^{\mathfrak{S}_k \times \mu_2, \text{sgn}}$.

Lemma 7.2. *The isomorphism $\mathrm{gr}_{k+1}^W \mathbf{H}_{\mathrm{dR},c}^{k-1}(\mathcal{X})(-1)^{\mathfrak{S}_k \times \mu_2, \mathrm{sgn}} \simeq \mathbf{H}_{\mathrm{dR},\mathrm{mid}}^{k+1}(U, \tilde{f}_k)^{\mathfrak{S}_k \times \mu_2, \mathrm{sgn}}$ of [Fresán et al. 2022, Theorem 3.8] identifies the \mathbb{Q} -vector spaces $(\mathbf{M}_k)_{\mathrm{dR}}$ and $\mathbf{H}_{\mathrm{dR},\mathrm{mid}}^{k+1}(U_0, \tilde{f}_k)^{\mathfrak{S}_k \times \mu_2, \mathrm{sgn}}$.*

Proof. We start from Example A.28, on noting that $\tilde{f}_k = t g_k$. We thus obtain isomorphisms (setting $Z_0 = \mathbb{A}_t^1 \times \mathcal{X}_0$)

$$\mathbf{H}_{\mathrm{dR},c}^{k+1}(Z_0)^{\mathfrak{S}_k \times \mu_2, \mathrm{sgn}} \simeq \mathbf{H}_{\mathrm{dR},c}^{k+1}(\mathbb{A}_t^1 \times \mathbb{G}_m^k/\mathbb{Q}, \tilde{f}_k)^{\mathfrak{S}_k \times \mu_2, \mathrm{sgn}} \simeq \mathbf{H}_{\mathrm{dR},c}^{k+1}(U_0, \tilde{f}_k)^{\mathfrak{S}_k \times \mu_2, \mathrm{sgn}},$$

where the second isomorphism is obtained as in the proof of [Fresán et al. 2022, Theorem 3.8]. After extension of scalars from \mathbb{Q} to \mathbb{C} , these isomorphisms become the de Rham part of the isomorphisms considered in the proof of [loc. cit.]. Since the left-hand sides are defined from Nori motives, the weight filtration is defined on them. We note that $(\mathbf{M}_k)_{\mathrm{dR}} \simeq \mathbf{H}_{\mathrm{dR},c}^{k+1}(Z_0)^{\mathfrak{S}_k \times \mu_2, \mathrm{sgn}}/W_k \mathbf{H}_{\mathrm{dR},c}^{k+1}(Z_0)^{\mathfrak{S}_k \times \mu_2, \mathrm{sgn}}$ because this holds after extension of scalars. Furthermore, the composition

$$\mathbf{H}_{\mathrm{dR},c}^{k+1}(Z_0)^{\mathfrak{S}_k \times \mu_2, \mathrm{sgn}} \xrightarrow{\sim} \mathbf{H}_{\mathrm{dR},c}^{k+1}(U_0, \tilde{f}_k)^{\mathfrak{S}_k \times \mu_2, \mathrm{sgn}} \rightarrow \mathbf{H}_{\mathrm{dR}}^{k+1}(U_0, \tilde{f}_k)^{\mathfrak{S}_k \times \mu_2, \mathrm{sgn}}$$

whose image is $\mathbf{H}_{\mathrm{dR},\mathrm{mid}}^{k+1}(U_0, \tilde{f}_k)^{\mathfrak{S}_k \times \mu_2, \mathrm{sgn}}$ by definition, has kernel equal to $W_k \mathbf{H}_{\mathrm{dR},c}^{k+1}(Z_0)^{\mathfrak{S}_k \times \mu_2, \mathrm{sgn}}$, because this holds after extension of scalars. This proves the lemma. \square

The Betti realization $(\mathbf{M}_k)_B$. We use the notation and apply the results of Section A3, more specifically Formulas (A.19), (A.20) and (A.21), to the pair (U, \tilde{f}_k) . Since \tilde{f}_k is invariant under the action of $\mathfrak{S}_k \times \mu_2$ on U , as well as under the action of complex conjugation $\mathrm{conj} : U(\mathbb{C}) \rightarrow U(\mathbb{C})$, the families of supports Φ_{rd} and Φ_{mod} are also invariant under these actions. There is thus a natural action of $\mathfrak{S}_k \times \mu_2$ on $\mathbf{H}_c^{k+1}(\tilde{U}_{\mathrm{rd}}(D), \mathbb{Q})$ and $\mathbf{H}_c^{k+1}(\tilde{U}_{\mathrm{mod}}(D), \mathbb{Q})$. We thus have

$$\begin{aligned} (\mathbf{M}_k)_B &\simeq \mathbf{H}_{B,\mathrm{mid}}^{k+1}(U, \tilde{f}_k)^{\mathfrak{S}_k \times \mu_2, \mathrm{sgn}} \\ &= \mathrm{im}[\mathbf{H}_{B,c}^{k+1}(U, \tilde{f}_k)^{\mathfrak{S}_k \times \mu_2, \mathrm{sgn}} \rightarrow \mathbf{H}_B^{k+1}(U, \tilde{f}_k)^{\mathfrak{S}_k \times \mu_2, \mathrm{sgn}}] \\ &\simeq \mathrm{im}[\mathbf{H}_c^{k+1}(\tilde{U}_{\mathrm{rd}}(D), \mathbb{Q})^{\mathfrak{S}_k \times \mu_2, \mathrm{sgn}} \rightarrow \mathbf{H}_c^{k+1}(\tilde{U}_{\mathrm{mod}}(D), \mathbb{Q})^{\mathfrak{S}_k \times \mu_2, \mathrm{sgn}}]. \end{aligned} \tag{7.3}$$

Lemma 7.4. *Under the identification (7.3), the action of the conjugation on $(\mathbf{M}_k)_B$ coincides with that on $\mathbf{H}_{B,\mathrm{mid}}^{k+1}(U, \tilde{f}_k)^{\mathfrak{S}_k \times \mu_2, \mathrm{sgn}}$.*

Proof. We start from the identification of Example A.31. Since the action of $\mathfrak{S}_k \times \mu_2$ on $\mathbb{A}_t^1 \times \mathbb{G}_m^k$ commutes with conj , we obtain an identification

$$(\mathbf{M}_k)_B \simeq \mathbf{H}_{B,\mathrm{mid}}^{k+1}(\mathbb{A}_t^1 \times \mathbb{G}_m^k, \tilde{f}_k)^{\mathfrak{S}_k \times \mu_2, \mathrm{sgn}}$$

compatible with conj^* . Since the isomorphism (see [Fresán et al. 2022, Proof of Theorem 3.8])

$$\mathbf{H}_{B,\mathrm{mid}}^{k+1}(\mathbb{A}_t^1 \times \mathbb{G}_m^k, \tilde{f}_k)^{\mathfrak{S}_k \times \mu_2, \mathrm{sgn}} \simeq \mathbf{H}_{B,\mathrm{mid}}^{k+1}(U, \tilde{f}_k)^{\mathfrak{S}_k \times \mu_2, \mathrm{sgn}}$$

is clearly compatible with conj^* the desired result follows. \square

The Betti realization is also given by (see (A.22))

$$(\mathbf{M}_k)_B \simeq \mathrm{im}[\mathbf{H}_{k+1}^{\mathrm{rd}}(U, \tilde{f}_k)^{\mathfrak{S}_k \times \mu_2, \mathrm{sgn}} \rightarrow \mathbf{H}_{k+1}^{\mathrm{mod}}(U, \tilde{f}_k)^{\mathfrak{S}_k \times \mu_2, \mathrm{sgn}}]$$

and carries the involution $F_\infty = \text{conj}_k$. Indeed, the expression (A.24) makes explicit the interpretation of the elements of $H_{k+1}^{\text{rd}}(U, \tilde{f}_k)$ in terms of twisted cycles. It is moreover clear that, in this expression, the closed subspace $\partial_{\text{rd},R}U$ of $U(\mathbb{C})$, upon which $\exp(-\tilde{f}_k)$ is sufficiently small, is invariant under both the action of $\mathfrak{S}_k \times \mu_2$ and the complex conjugation on $U(\mathbb{C})$, which thus provides the action of $\mathfrak{S}_k \times \mu_2$ and F_∞ on $H_{k+1}^{\text{rd}}(U, \tilde{f}_k)$.

Self-duality and period pairing. The involution ι yields the identifications

$$\mu : H_?^{k+1}(U, \tilde{f}_k) \xrightarrow{\sim} H_?^{k+1}(U, -\tilde{f}_k), \quad ? = \emptyset, \mathfrak{c},$$

compatible with the action of $\mathfrak{S}_k \times \mu_2$, and leads to the self-duality up to a Tate twist by $\mathbb{Q}(k+1)$ of the mixed Hodge structure $(M_k)_\mathbb{H} \simeq H_{\text{mid}}^{k+1}(U, \tilde{f}_k)^{\mathfrak{S}_k \times \mu_2, \text{sgn}}$.

The nondegenerate period pairing

$$P^{\text{rd}, \text{mod}} : H_{k+1}^{\text{rd}}(U, \tilde{f}_k)^{\mathfrak{S}_k \times \mu_2, \text{sgn}} \otimes H_{\text{dR}}^{k+1}(U, \tilde{f}_k)^{\mathfrak{S}_k \times \mu_2, \text{sgn}} \rightarrow \mathbb{C},$$

is computed as follows. Given a twisted cycle

$$\alpha \in H_{k+1}^{\text{rd}}(U, \tilde{f}_k)^{\mathfrak{S}_k \times \mu_2, \text{sgn}} = H_{k+1}(\tilde{U}_{\text{rd}}, \partial \tilde{U}_{\text{rd}}, \mathbb{Q})^{\mathfrak{S}_k \times \mu_2, \text{sgn}},$$

we choose for each large enough $R > 0$ a representative $\alpha_R \in H_{k+1}(U, \partial_{\text{rd},R}U, \mathbb{Q})$ sgn-invariant under $\mathfrak{S}_k \times \mu_2$. We also represent a de Rham class in the space $H_{\text{dR}}^{k+1}(U, \tilde{f}_k)^{\mathfrak{S}_k \times \mu_2, \text{sgn}}$ by a top differential form ω on U which is sgn-invariant under $\mathfrak{S}_k \times \mu_2$. Then

$$P^{\text{rd}, \text{mod}}(\alpha, [\omega]) = \lim_{R \rightarrow \infty} \int_{\alpha_R} e^{-\tilde{f}_k} \iota^* \omega.$$

7.2. Proof of Theorem 7.1. The goal of this section is to identify the period structure

$$(H_{\text{dR}, \text{mid}}^{k+1}(U_0, \tilde{f}_k)^{\mathfrak{S}_k \times \mu_2, \text{sgn}}, H_{\text{B}, \text{mid}}^{k+1}(U, \tilde{f}_k)^{\mathfrak{S}_k \times \mu_2, \text{sgn}}, \text{comp})$$

as defined from Sections A2 and A3 with the transpose of

$$(H_{\text{dR}, \text{mid}}^1(\mathbb{G}_m, \text{Sym}^k \text{Kl}_2)_\mathbb{Q}, H_1^{\text{mid}}(\mathbb{G}_m, \text{Sym}^k \text{Kl}_2)_\mathbb{Q}, P_k^{\text{mid}}),$$

ending thereby the proof of Theorem 7.1, and to make explicit the action of F_∞ on $H_1^{\text{mid}}(\mathbb{G}_m, \text{Sym}^k \text{Kl}_2)_\mathbb{Q}$.

Summary of the proof.

Step 1 We consider the family $(w_j)_{0 \leq j \leq k'}$ in $H_{\text{dR}}^{k+1}(U_0, \tilde{f}_k)^{\mathfrak{S}_k \times \mu_2, \text{sgn}}$ as defined in [Fresán et al. 2022, proof of Proposition 4.21], which has been shown to form a \mathbb{Q} -basis of this space.

Step 2 We construct a family of rapid decay cycles (τ_i) in $H_{k+1}^{\text{rd}}(U, \tilde{f}_k)^{\mathfrak{S}_k \times \mu_2, \text{sgn}}$ such that the matrix $(P^{\text{rd}, \text{mod}}(\tau_i, w_j))_{0 \leq i, j \leq k'}$ is equal to $(P_{k; i, j}^{\text{rd}, \text{mod}})_{0 \leq i, j \leq k'}$ obtained from Propositions 5.4 and 6.2. Since this matrix is nondegenerate and (w_j) is a basis of $H_{\text{dR}}^{k+1}(U, \tilde{f}_k)^{\mathfrak{S}_k \times \mu_2, \text{sgn}}$, we conclude that (τ_i) is a basis of $H_{\text{rd}}^{k+1}(U, \tilde{f}_k)^{\mathfrak{S}_k \times \mu_2, \text{sgn}}$.

Step 3 According to [Remark A.25](#), the period realization of $H^{k+1}(U_0, \tilde{f}_k)^{\mathfrak{S}_k \times \mu_2, \text{sgn}}$ is isomorphic to

$$(\mathbb{Q} \cdot (w_j), \mathbb{Q} \cdot (\tau_i), (P_{i,j}^{\text{rd,mod}})_{0 \leq i, j \leq k'}),$$

hence to

$$(\mathbb{Q} \cdot (\omega_j), \mathbb{Q} \cdot (\alpha_i), (P_{k;i,j}^{\text{rd,mod}})_{0 \leq i, j \leq k'}),$$

that is,

$$(H_{\text{dR}}^1(\mathbb{G}_m, \text{Sym}^k \text{Kl}_2)_{\mathbb{Q}}, H_1^{\text{rd}}(\mathbb{G}_m, \text{Sym}^k \text{Kl}_2)_{\mathbb{Q}}, P_k^{\text{rd,mod}}).$$

Step 4 Owing to the duality argument explained in [\[Fresán et al. 2023, Lemma 2.27\]](#), the same property holds for the period realization of $H_c^{k+1}(U_0, \tilde{f}_k)^{\mathfrak{S}_k \times \mu_2, \text{sgn}}$ and

$$(H_{\text{dR},c}^1(\mathbb{G}_m, \text{Sym}^k \text{Kl}_2)_{\mathbb{Q}}, H_1^{\text{mod}}(\mathbb{G}_m, \text{Sym}^k \text{Kl}_2)_{\mathbb{Q}}, P_k^{\text{mod,rd}}).$$

Step 5 That the same property holds true for the period realization of $H_{\text{mid}}^{k+1}(U_0, \tilde{f}_k)^{\mathfrak{S}_k \times \mu_2, \text{sgn}}$ and

$$(H_{\text{dR,mid}}^1(\mathbb{G}_m, \text{Sym}^k \text{Kl}_2)_{\mathbb{Q}}, H_1^{\text{mid}}(\mathbb{G}_m, \text{Sym}^k \text{Kl}_2)_{\mathbb{Q}}, P_k^{\text{mid}})$$

needs a supplementary argument when $k \equiv 0 \pmod 4$.

Step 6 Lastly, that conjugation is compatible with these identifications amounts to checking whether the entries of the period matrix are real or purely imaginary.

A basis of $H_{\text{dR}}^{k+1}(U_0, \tilde{f}_k)^{\mathfrak{S}_k \times \mu_2, \text{sgn}}$. Let us consider the class $[\tilde{\omega}_j]$ of

$$\tilde{\omega}_j = 2^{1-2j} t^{2j-1} dt \wedge \frac{dy_1}{y_1} \wedge \dots \wedge \frac{dy_k}{y_k}$$

in $H_{\text{dR}}^{k+1}(U_0, \tilde{f}_k)$ and set

$$w_j = \frac{1}{2k!} \sum_{\sigma \in \mathfrak{S}_k \times \mu_2} \text{sgn}(\sigma) \cdot \sigma([\tilde{\omega}_j]) \in H_{\text{dR}}^{k+1}(U_0, \tilde{f}_k)^{\mathfrak{S}_k \times \mu_2, \text{sgn}}. \tag{7.5}$$

Through the isomorphism (see [\[Fresán et al. 2022, Proposition 2.13\]](#))

$$H_{\text{dR}}^1(\mathbb{G}_m, \text{Sym}^k \text{Kl}_2) \simeq H_{\text{dR}}^{k+1}(U, \tilde{f}_k)^{\mathfrak{S}_k \times \mu_2, \text{sgn}},$$

each class $[z^j v_0^k dz/z]$ in the basis \mathcal{B}_k corresponds to the class w_j ; see [\[loc. cit., proof of Proposition 4.21\]](#). As a consequence, $(w_j)_{0 \leq j \leq k'}$ forms a basis of $H_{\text{dR}}^{k+1}(U_0, \tilde{f}_k)^{\mathfrak{S}_k \times \mu_2, \text{sgn}}$ satisfying $\iota^* w_j = w_j$.

A family of rapid decay cycles. For each i such that $0 \leq i \leq k'$, we define rapid decay cycles $\tilde{\alpha}_i$ as follows. First, let $\tilde{\alpha}_0$ be the bounded cycle

$$\tilde{\alpha}_0 = \prod_{p=0}^k c_p,$$

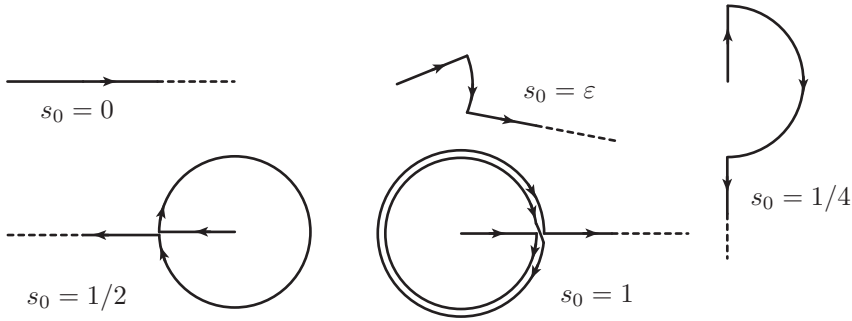

Figure 1. The path $s_p \mapsto y_p(s_0, s_p)$ for s_0 fixed and $r \leq p \leq k$.

where c_0 is the circle $|t| = 1$ and c_p is the circle $|y_p| = 1$ for $p = 1, \dots, k$, both oriented counterclockwise. For the remaining unbounded cycles, we start with the chain

$$\tilde{\alpha}'_i = [1, +\infty) \times \left(\prod_{p=1}^i c_p \right) \times (\mathbb{R}_{>0})^{k-i}$$

on $U(\mathbb{C})$, where $[1, +\infty)$ is relative to the variable t and the open octant $(\mathbb{R}_{>0})^{k-i}$ is relative to the variables y_p for $p = i + 1, \dots, k$. The orientation is the natural one on each half-line, and given by the order of the variables for $\tilde{\alpha}'_i$. Since $\text{Re}(y_p + 1/y_p) \geq -2$ on c_p and ≥ 2 on $\mathbb{R}_{>0}$, by noting that $k - i > i$ for $1 \leq i \leq k'$, one sees that $e^{-\tilde{f}_k}$ has rapid decay along $\tilde{\alpha}'_i$. The rapid decay chain $\tilde{\alpha}'_i$ has boundary

$$\partial \tilde{\alpha}'_i = -\{1\} \times \left(\prod_{p=1}^i c_p \right) \times (\mathbb{R}_{>0})^{k-i},$$

and hence is not a cycle. To kill the boundary, we mimic the construction of the cycles α_i from (4.4) by introducing, for each r such that $1 \leq r \leq k'$, the chain $\tilde{\gamma}_r$ defined as the image of the map $[0, 1]^r \times (0, 1)^{k-r+1} \rightarrow U(\mathbb{C})$ given by

$$(s_0, \dots, s_k) \mapsto \begin{cases} t = e^{2\pi i s_0}, \\ y_p = e^{2\pi i s_p} & 1 \leq p \leq r-1, \\ y_p = \begin{cases} e^{2\pi i s_0} \cdot 4s_p & 0 < s_p \leq 1/4, \\ e^{2\pi i s_0(2-4s_p)} & 1/4 \leq s_p \leq 3/4, \\ e^{-2\pi i s_0} (1 + \tan \frac{\pi}{2}(4s_p - 3)) & 3/4 \leq s_p < 1, \end{cases} & r \leq p \leq k. \end{cases}$$

(See Figure 1.) The chain $\tilde{\gamma}_r$ decays rapidly for $e^{-\tilde{f}_k}$ with boundary

$$\partial \tilde{\gamma}_r = \{1\} \times \left(\prod_{p=1}^{r-1} c_p \right) \times \prod_{p=r}^k (\mathbb{R}_{>0} - 2c_p) - \{1\} \times \left(\prod_{p=1}^{r-1} c_p \right) \times (\mathbb{R}_{>0})^{k-r}.$$

For each integer $m \geq 1$, there is a unique sequence $(\theta_m(r))_{0 \leq r \leq m-1}$ of rational numbers satisfying the identity

$$\sum_{r=0}^{m-1} \theta_m(r) a^r [(a+b)^{m-r} - b^{m-r}] = ab^{m-1} \tag{7.6}$$

in the polynomial ring $\mathbb{Q}[a, b]$. Explicitly, the first two values are $\theta_m(0) = 1/m$ and $\theta_m(1) = -1/2$ and the recursion

$$\sum_{r=0}^{\ell-1} \binom{m-r}{m-\ell} \theta_m(r) = 0 \tag{7.7}$$

holds if $1 < \ell < m$. Set

$$\tilde{\theta}_m = \sum_{r=0}^{m-1} \frac{\theta_m(r)}{m-r+1}.$$

For each i such that $1 \leq i \leq k'$, let

$$\tilde{\alpha}_i = -(-2)^{k-i} \tilde{\theta}_{k-i+1} \tilde{\alpha}_0 + \frac{1}{(k-i+1)!} \sum_{\sigma \in \mathfrak{S}_{k-i+1}} \sigma \left(\tilde{\alpha}'_i + \sum_{r=i}^k (-2)^{r-i-1} \theta_{k-i+1}(r-i) \tilde{\gamma}_r \right),$$

where the symmetric group \mathfrak{S}_j acts by permuting the last j components. We compute the boundary of the terms involving $\tilde{\gamma}_r$. Since the average over the group action makes the positions of circles and lines from $\partial \tilde{\gamma}_r$ equidistributed in the last $k-i+1$ components, for each fixed j such that $1 \leq j \leq k-i$ and any $\sigma \in \mathfrak{S}_{k-i+1}$, the coefficient in the boundary of the term $\sigma(\{1\} \times \prod_{p=1}^{i+j-1} c_p \times \prod_{p=i+j}^k \mathbb{R}_{>0})$, resulting from $\tilde{\gamma}_r$ for $i \leq r \leq i+j-1$, is equal to

$$\begin{aligned} \sum_{r=i}^{i+j-1} (-2)^{r-i-1} \theta_{k-i+1}(r-i) \binom{k+1-r}{i+j-r} (-2)^{i+j-r} &= (-2)^{j-1} \sum_{\ell=0}^{j-1} \theta_{k-i+1}(\ell) \binom{k-i+1-\ell}{j-\ell} \\ &= \begin{cases} 1 & \text{if } j = 1, \\ 0 & \text{if } 1 < j < k-i+1, \end{cases} \end{aligned}$$

where the last equality follows from (7.7). One concludes that the $\tilde{\alpha}_i$ define rapid decay cycles.

Remark 7.8. In fact, $\theta_m(r) = \binom{m}{r} \mathcal{B}_r / m$ if $0 \leq r < m$, and $\tilde{\theta}_m = -\mathcal{B}_m / m$ for all $m \geq 1$. To see this, plugging $a = 1$ into (7.6) and summing the resulting equations for $b = 1, \dots, n$, one obtains

$$\sum_{\ell=0}^{m-1} n^{m-\ell} \sum_{r=0}^{\ell} \binom{m-r}{m-\ell} \theta_m(r) = \sum_{b=1}^n b^{m-1},$$

and hence by Bernoulli's formula (4.3),

$$\sum_{r=0}^{\ell} \binom{m-r}{m-\ell} \theta_m(r) = \frac{(-1)^\ell}{m} \binom{m}{\ell} \mathcal{B}_\ell, \quad 0 \leq \ell < m.$$

Using (7.7) and the equalities $\theta_m(0) = \mathcal{B}_0/m$, $\theta_m(1) = \mathcal{B}_1$ and $\mathcal{B}_{2p+1} = 0$ for $p \geq 1$, we obtain the identity for $\theta_m(r)$. Therefore,

$$\tilde{\theta}_m = \frac{1}{m} \sum_{r=0}^{m-1} \frac{1}{m-r+1} \binom{m}{r} \mathcal{B}_r = \frac{1}{m(m+1)} \sum_{r=0}^{m-1} \binom{m+1}{r} \mathcal{B}_r,$$

and the identity for $\tilde{\theta}_m$ follows from the recursive relation $\sum_{r=0}^m \binom{m+1}{r} \mathcal{B}_r = 0$ for all $m \geq 1$.

Lemma 7.9. *For any positive integer m , the following identity holds in $\mathbb{Q}[a, b]$:*

$$\sum_{r=0}^{m-1} \frac{\theta_m(r)}{m-r+1} a^{r-1} [(a+b)^{m-r+1} - b^{m-r+1}] = \tilde{\theta}_m a^m + \frac{b^m}{m}. \tag{7.10}$$

Proof. Integrating equation (7.6) with respect to b from 0 to b yields the formula. □

Proposition 7.11. *The period pairing*

$$\text{Prd.mod} : \mathbf{H}_{k+1}^{\text{rd}}(U, \tilde{f}_k) \otimes \mathbf{H}_{\text{dR}}^{k+1}(U, \tilde{f}_k) \rightarrow \mathbb{C}$$

is given on the rapid decay cycles $\tilde{\alpha}_i$ and the differential forms $\tilde{\omega}_j$ by

$$\text{Prd.mod}(\tilde{\alpha}_i, \tilde{\omega}_j) = \begin{cases} 2(2\pi i)^{k+1} \delta_{0,j} & \text{if } i = 0, \\ (-1)^{k-i} \text{BM}_k^{\text{reg}}(i, -1) & \text{if } j = 0 \text{ and } 1 \leq i \leq k', \\ (-1)^{k-i} \text{BM}_k(i, 2j-1) & \text{if } 1 \leq i, j \leq k'. \end{cases}$$

Proof. It is clear that $\text{Prd.mod}(\tilde{\alpha}_0, \tilde{\omega}_j) = 2(2\pi i)^{k+1} \delta_{0,j}$.

For the rest, as in the proof of Proposition 6.2, for $\varepsilon \in \mathbb{R}_{>0}$, we let $\tilde{\alpha}'_{i,\varepsilon} = \varepsilon \tilde{\alpha}'_i$ and $\tilde{\gamma}_{r,\varepsilon} = \varepsilon \tilde{\gamma}_r$ be the scalings of $\tilde{\alpha}'_i$ and $\tilde{\gamma}_r$, which are homologous to $\tilde{\alpha}'_i$ and $\tilde{\gamma}_r$, respectively. Consider the case $j = 0$. By the limiting behavior (2.13) and Definition 6.1 of the regularized Bessel moments, we have the limiting behaviors

$$\begin{aligned} \int_{\tilde{\alpha}'_{i,\varepsilon}} e^{-\tilde{f}_k} \tilde{\omega}_0 &= 2^{k+1} (\pi i)^i \int_{\varepsilon}^{\infty} I_0(t)^i K_0(t)^{k-i} \frac{dt}{t} \\ &\sim_{\varepsilon \rightarrow 0^+} (-1)^{k-i} \text{BM}_k^{\text{reg}}(i, -1) + \frac{(-1)^{k-i+1} 2^{k+1} (\pi i)^i}{k-i+1} (\gamma + \log(\varepsilon/2))^{k-i+1}, \\ \int_{\tilde{\gamma}_{r,\varepsilon}} e^{-\tilde{f}_k} \tilde{\omega}_0 &= 2^{k+1} (\pi i)^{r-1} \int_{|t|=\varepsilon} I_0(t)^{r-1} K_0(t)^{k-r+1} \frac{dt}{t} \\ &\sim_{\varepsilon \rightarrow 0^+} \frac{(-1)^{k-r+1} 2^{k+1} (\pi i)^{r-1}}{k-r+2} \cdot [(2\pi i + \gamma + \log(\varepsilon/2))^{k-r+2} - (\gamma + \log(\varepsilon/2))^{k-r+2}]. \end{aligned}$$

Substituting $m = k - i + 1$, $a = 2\pi i$, and $b = \gamma + \log \varepsilon/2$ into the identity (7.10), one obtains

$$\begin{aligned} \sum_{r=i}^k (-2)^{r-i-1} \theta_{k-i+1}(r-i) \int_{\tilde{\gamma}_{r,\varepsilon}} e^{-\tilde{f}_k} \tilde{\omega}_0 \\ \sim_{\varepsilon \rightarrow 0^+} -(-2)^{k-i+1} (2\pi i)^{k+1} \tilde{\theta}_{k-i+1} + \frac{(-1)^{k-i} 2^{k+1} (\pi i)^i}{k-i+1} (\gamma + \log(\varepsilon/2))^{k-i+1}. \end{aligned}$$

Letting $\varepsilon \rightarrow 0^+$ leads to $\mathrm{P}^{\mathrm{rd},\mathrm{mod}}(\tilde{\alpha}_i, \tilde{\omega}_0) = (-1)^{k-i} \mathrm{BM}_k^{\mathrm{reg}}(i, -1)$.

Finally, if $1 \leq i, j \leq k'$, it is straightforward to verify that

$$\lim_{\varepsilon \rightarrow 0^+} \int_{\tilde{\alpha}'_{i,\varepsilon}} e^{-\tilde{f}_k} \tilde{\omega}_j = (-1)^{k-i} \mathrm{BM}_k(i, 2j - 1) \quad \text{and} \quad \lim_{\varepsilon \rightarrow 0^+} \int_{\tilde{\gamma}_{i,\varepsilon}} e^{-\tilde{f}_k} \tilde{\omega}_j = 0$$

(similar to the proof of Proposition 5.4), and the remaining case follows. □

Starting from the $\tilde{\alpha}_i$, we obtain the following cycles in $\mathrm{H}_{k+1}^{\mathrm{rd}}(U, \tilde{f}_k)^{\mathfrak{S}_k \times \mu_2, \mathrm{sgn}}$:

$$\tau_0 = \frac{1}{k!} \sum_{\sigma \in \mathfrak{S}_k \times \mu_2} \mathrm{sgn}(\sigma) \cdot \sigma(\tilde{\alpha}_0), \quad \tau_i = \frac{(-1)^{k-i}}{2k!} \sum_{\sigma \in \mathfrak{S}_k \times \mu_2} \mathrm{sgn}(\sigma) \cdot \sigma(\tilde{\alpha}_i) \quad (1 \leq i \leq k').$$

For each i such that $1 \leq i \leq k'$, let Γ_i denote the image of τ_i in $\mathrm{H}_{k+1}^{\mathrm{mod}}(U, \tilde{f}_k)^{\mathfrak{S}_k \times \mu_2, \mathrm{sgn}}$.

Corollary 7.12. (1) *The family $(\tau_i)_{0 \leq i \leq k'}$ forms a basis of $\mathrm{H}_{k+1}^{\mathrm{rd}}(U, \tilde{f}_k)^{\mathfrak{S}_k \times \mu_2, \mathrm{sgn}}$.*

(2) *The period realizations*

- of $\mathrm{H}_c^1(\mathbb{G}_m, \mathrm{Sym}^k \mathrm{Kl}_2)$ and of $\mathrm{H}_c^{k+1}(U_0, \tilde{f}_k)^{\mathfrak{S}_k \times \mu_2, \mathrm{sgn}}$,
- as well as those of $\mathrm{H}^1(\mathbb{G}_m, \mathrm{Sym}^k \mathrm{Kl}_2)$ and $\mathrm{H}^{k+1}(U_0, \tilde{f}_k)^{\mathfrak{S}_k \times \mu_2, \mathrm{sgn}}$,

are isomorphic.

(3) *If k is not a multiple of 4, the family $(\Gamma_i)_{1 \leq i \leq k'}$ forms a basis of $(\mathrm{M}_k)_{\mathbb{B}}$. If k is a multiple of 4, the \mathbb{Q} -linear relation*

$$\sum_{i=0}^{\lfloor (k-2)/4 \rfloor} \binom{k/2}{2i+1} \Gamma_{2i+1} = 0$$

holds and $(\Gamma_i)_{2 \leq i \leq k'}$ forms a basis of $(\mathrm{M}_k)_{\mathbb{B}}$. In particular, the period realization of the motive M_k is isomorphic to

$$(\mathrm{H}_{\mathrm{dR},\mathrm{mid}}^1(\mathbb{G}_m, \mathrm{Sym}^k \mathrm{Kl}_2)_{\mathbb{Q}}, \mathrm{H}_1^{\mathrm{mid}}(\mathbb{G}_m, \mathrm{Sym}^k \mathrm{Kl}_2)_{\mathbb{Q}}, \mathrm{P}_k^{\mathrm{mid}}).$$

(4) *The involution F_∞ acts as $F_\infty(\Gamma_i) = (-1)^i \Gamma_i$ for all i such that $1 \leq i \leq k'$.*

Proof. For each i such that $0 \leq i \leq k'$, equation (5.1), Propositions 5.4, 6.2 and 7.11 yield the equality of periods $\mathrm{P}^{\mathrm{rd},\mathrm{mod}}(\tau_i, w_j) = \mathrm{P}_k^{\mathrm{rd},\mathrm{mod}}(\alpha_i, \omega_j)$ for all j such that $0 \leq j \leq k'$ (with w_j defined by (7.5)), from which (1) follows, as indicated in Step 2 of the summary. The proof of (2) has been explained in Step 3 and Step 4 of the summary.

In view of Theorem 4.7(3) and Proposition 6.10, to prove (3), it suffices to show that $\mathrm{P}^{\mathrm{mid}}(\Gamma_i, w_j) = \mathrm{P}_k^{\mathrm{mid}}(\beta_i, \omega_j)$ for all i, j such that $1 \leq i, j \leq k'$. Since Γ_i and β_i are the images of the rapid decay cycles τ_i and α_i respectively and the pairing $\mathrm{P}_k^{\mathrm{mid}}$ is induced by $\mathrm{P}^{\mathrm{rd},\mathrm{mod}}$, this amounts to $\mathrm{P}^{\mathrm{rd},\mathrm{mod}}(\tau_i, w_j) = \mathrm{P}_k^{\mathrm{rd},\mathrm{mod}}(\alpha_i, \omega_j)$, which we just checked.

Finally, the statement about F_∞ follows from the fact that the period pairing Prd,mod is compatible with complex conjugation in that (recall that $\iota^* w_j = w_j$ and $\text{conj}^* w_j = w_j$),

$$\text{Prd,mod}(\text{conj}_* \tau_i, w_j) = \int_{F_\infty \tau_i} e^{-\tilde{f}_k} w_j = \int_{\text{conj}_* \tau_i} \text{conj}^*(e^{-\tilde{f}_k} w_j) = \overline{\text{Prd,mod}(\tau_i, w_j)} \quad \text{for all } i, j,$$

along with the equality $\overline{\text{Prd,mod}(\tau_i, w_j)} = (-1)^i \text{Prd,mod}(\tau_i, w_j)$ if $1 \leq i, j \leq k'$, since $\text{BM}_k(i, 2j - 1)$ is real for even i and purely imaginary for odd i . □

8. L-functions of Kloosterman sums and Bessel moments

In this section, we make precise the statement of Deligne’s conjecture for the motive M_k . Being a classical motive, M_k has an associated L -function $L(\text{M}_k, s)$, which is identified in [Fresán et al. 2022, Theorems 5.8 and 5.17] with the L -function $L_k(s)$ of symmetric power moments of Kloosterman sums, and its Betti realization $(\text{M}_k)_\mathbb{B}$ carries a pure Hodge structure of weight $k + 1$. The factor at infinity was computed in [loc. cit., Corollary 5.30]:

$$L_\infty(\text{M}_k, s) = \pi^{-ms/2} \prod_{j=1}^m \Gamma\left(\frac{s-j}{2}\right), \tag{8.1}$$

where $m = k'$ if k is not a multiple of 4 and $m = k' - 1$ otherwise. This also follows from Corollary 7.12(4): indeed, according to [loc. cit., Theorem 1.8], the only nontrivial Hodge numbers of M_k are

$$h^{p,q} = \begin{cases} 1 & \text{for } p = 2, \dots, k - 1 \text{ if } k \text{ is odd} \\ 1 & \text{for } \min\{p, q\} = 2, \dots, 2\lfloor(k - 1/4)\rfloor \text{ if } k \text{ is even.} \end{cases}$$

The ordered basis $\mathcal{B}_{k,\text{mid}}$ is adapted to the Hodge filtration by Corollary 3.21, and F_∞ acts as -1 on $H^{p,p}$ for $k \equiv 3 \pmod{4}$, which is what we need for the conclusion.

By [loc. cit., Theorems 1.2 and 1.3], the L -function $L(\text{M}_k, s)$ extends meromorphically to the complex plane and the completed L -function

$$\Lambda(\text{M}_k, s) = L(\text{M}_k, s)L_\infty(\text{M}_k, s)$$

satisfies a functional equation relating its values at s and $k + 2 - s$. The *critical integers* are the integral values of s at which neither $L_\infty(\text{M}_k, s)$ nor $L_\infty(\text{M}_k, k + 2 - s)$ has a pole and the *critical values* are the values of $L(\text{M}_k, s)$ at critical integers.

Deligne’s conjecture [1979, Section 1] predicts that critical values agree, up to a rational factor, with the determinants of certain minors of the period matrix, which are defined as follows. Let a be an integer, and let $\text{M}_k(a)_\mathbb{B}^+$ and $\text{M}_k(a)_\mathbb{B}^-$ denote respectively the invariants and antiinvariants of F_∞ acting on $\text{M}_k(a)_\mathbb{B}$. As F_∞ exchanges the subspaces $H^{p-a, q-a}$ and $H^{q-a, p-a}$ in the Hodge decomposition and acts as -1 on $H^{p-a, p-a}$, the eigenspaces for F_∞ have dimensions either $\sum_{p>q} h^{p-a, q-a}$ or $\sum_{p\geq q} h^{p-a, q-a}$, and there exists unique steps $F^\pm \text{M}_k(a)_{\text{dR}}$ of the Hodge filtration with $\dim F^\pm \text{M}_k(a)_{\text{dR}} = \dim \text{M}_k(a)_\mathbb{B}^\pm$. If n is a

k	rank	critical integers n	c_n
3	1	$2 - 2a$ $2a + 3$	1 $\pi^{2a} D_{3,\text{odd}}$
$4r + 1$	$2r$	$2r + 1$ $2r + 2$	$\pi^{-r(r+1)} D_{k,\text{odd}}$ $\pi^{-r(r-1)} D_{k,\text{even}}$
$4r + 2$	$2r$	$2r + 1$ $2r + 2$ $2r + 3$	$\pi^{-r(r+1)} D_{k,\text{even}}$ $\pi^{-r(r+1)} D_{k,\text{odd}}$ $\pi^{-r(r-1)} D_{k,\text{even}}$
$4r + 3$	$2r + 1$	$2r + 2$ $2r + 3$	$\pi^{-r(r+1)} D_{k,\text{even}}$ $\pi^{-r(r+1)} D_{k,\text{odd}}$
$4r + 4$	$2r$	$2r + 1$ $2r + 2$ $2r + 3$ $2r + 4$ $2r + 5$	$\pi^{-r(r+3)} D'_{k,\text{even}}$ $\pi^{-r(r+3)} D'_{k,\text{odd}}$ $\pi^{-r(r+1)} D'_{k,\text{even}}$ $\pi^{-r(r+1)} D'_{k,\text{odd}}$ $\pi^{-r(r-1)} D'_{k,\text{even}}$

Table 1. Critical integers n and values of c_n ($r \geq 1$).

critical integer, Deligne defines

$$c_n = \det(\mathbb{P}_k^{\text{mid}}(\sigma_i, v_i)) \in \mathbb{C}^\times / \mathbb{Q}^\times$$

where σ_i runs through any basis of the \mathbb{Q} -linear dual of $\mathbb{M}_k(k + 1 - n)_\mathbb{B}^+$ and v_i runs through any basis of $F^+ \mathbb{M}_k(k + 1 - n)_{\text{dR}}$, see the paragraph before [Deligne 1979, Conjecture 1.8] taking the duality of pure Hodge structures $(\mathbb{M}_k)_\mathbb{H}^\vee \cong (\mathbb{M}_k)_\mathbb{H}(k + 1)$ from [Fresán et al. 2022, (3.4)] into account. He then conjectures that $L(\mathbb{M}_k, n)$ is a rational multiple of c_n .

Notation 8.2. For each $k \geq 3$, the determinants of Bessel moments $D_{k,\text{odd}}$ and $D_{k,\text{even}}$ are defined by the following formulas:

$$\begin{aligned}
 D_{k,\text{odd}} &= \det \left(\int_0^\infty I_0(t)^{2i-1} K_0(t)^{k+1-2i} t^{2j-1} dt \right)_{1 \leq i, j \leq \lfloor (k+1/4) \rfloor} \\
 D_{k,\text{even}} &= \det \left(\int_0^\infty I_0(t)^{2i} K_0(t)^{k-2i} t^{2j-1} dt \right)_{1 \leq i, j \leq \lfloor k/4 \rfloor}
 \end{aligned}
 \tag{8.3}$$

In other words, $D_{k,\text{odd}}$, resp. $D_{k,\text{even}}$, is obtained by extracting from $\mathbb{P}_k^{\text{mid}}$ the entries that belong to odd, resp. even, lines and to the first $\lfloor (k + 1/4) \rfloor$, resp. $\lfloor k/4 \rfloor$, columns. If k is a multiple of 4, we let $D'_{k,\text{odd}}$ and $D'_{k,\text{even}}$ be the determinants of the same matrices except that we remove the last row and column, i.e., those indexed by $i = j = k/4$.

Theorem 8.4. For $k = 3$ or $k \geq 5$, the critical integers n for $L(\mathbb{M}_k, s)$ and the corresponding values c_n are given by Table 1.

Proof. The case $k = 3$ is exceptional in that there exist infinitely many critical integers, namely all even integers ≤ 2 and all odd integers ≥ 3 . For each $k \geq 5$, a straightforward computation using (8.1) yields the list of critical integers. To compute c_n , we first exhibit a basis of the \mathbb{Q} -linear dual of $M_k(a)_\mathbb{B}^+$ by means of Corollary 7.12. If k is not a multiple of 4, a basis is given by $\{(2\pi i)^{-a} \Gamma_{2i}\}_{1 \leq i \leq \lfloor k'/2 \rfloor}$ if a is even and by $\{(2\pi i)^{-a} \Gamma_{2i-1}\}_{1 \leq i \leq \lfloor (k'+1)/2 \rfloor}$ if a is odd. If k is a multiple of 4, say $k = 4r + 4$, then the \mathbb{Q} -linear dual of $M_k(a)_\mathbb{B}^+$ has basis $\{(2\pi i)^{-a} \Gamma_{2i}\}_{1 \leq i \leq r}$ if a is even and $\{(2\pi i)^{-a} \Gamma_{2i+1}\}_{1 \leq i \leq r}$ if a is odd, which shows that $M_k(a)_\mathbb{B}^+$ always has dimension r .

Let us treat the case $k = 4r + 3$ in detail. For $n = 2r + 2$, the eigenspace $M_k(2r + 2)_\mathbb{B}^+$ has dimension r , and hence $F^+ M_k(2r + 2)_{\text{dR}}$ is spanned by $\{w_j\}_{1 \leq j \leq r}$. Therefore, c_{2r+2} is the determinant of the matrix with entries

$$(2\pi i)^{-(2r+2)} \text{Prd,mod}(\Gamma_{2i}, w_j) \sim_{\mathbb{Q}^\times} \pi^{2(i-r-1)} \int_0^\infty I_0(t)^{2i} K_0(t)^{k-2i} t^{2j-1} dt,$$

from which we get $c_{2r+2} = \pi^{-r(r+1)} D_{k,\text{even}}$. For $n = 2r + 3$, the eigenspace $M_k(2r + 1)_\mathbb{B}^+$ has dimension $r + 1$, and hence $F^+ M_k(2r + 1)_{\text{dR}}$ is spanned by $\{w_j\}_{1 \leq j \leq r+1}$. With respect to these bases, the matrix defining c_{2r+3} has entries

$$(2\pi i)^{-(2r+1)} \text{Prd,mod}(\Gamma_{2i-1}, w_j) \sim_{\mathbb{Q}^\times} \pi^{2(i-r-1)} \int_0^\infty I_0(t)^{2i-1} K_0(t)^{k+1-2i} t^{2j-1} dt,$$

which gives $c_{2r+3} = \pi^{-r(r+1)} D_{k,\text{odd}}$. The cases $k = 4r + 1$ and $k = 4r + 2$ are completely parallel.

For $k = 4r + 4$ and any critical value n , the eigenspace $M_k(4r + 5 - n)_\mathbb{B}^+$ has dimension r , and hence $F^+ M_k(4r + 5 - n)_{\text{dR}}$ is spanned by $\{w_j\}_{1 \leq j \leq r}$ (note that $r < k/4$, so that we do not need to modify the ω). If n is odd, c_n is the determinant of the matrix with entries

$$(2\pi i)^{-(4r+5-n)} \text{Prd,mod}(\Gamma_{2i}, w_j) \sim_{\mathbb{Q}^\times} \pi^{2i+n-4r-5} \int_0^\infty I_0(t)^{2i} K_0(t)^{k-2i} t^{2j-1} dt,$$

thus yielding

$$c_{2r+1} = \pi^{-r(r+3)} D'_{k,\text{even}}, \quad c_{2r+3} = \pi^{-r(r+1)} D'_{k,\text{even}}, \quad \text{and} \quad c_{2r+5} = \pi^{-r(r-1)} D'_{k,\text{even}}.$$

If n is even, the matrix has entries

$$(2\pi i)^{-(4r+5-n)} \text{Prd,mod}(\Gamma_{2i+1}, w_j).$$

Thanks to the linear relation from Corollary 7.12(3), the determinant of this matrix agrees up to a rational number with that of

$$\pi^{2i+n-4r-6} \int_0^\infty I_0(t)^{2i-1} K_0(t)^{k+1-2i} t^{2j-1} dt,$$

which gives the remaining values

$$c_{2r+2} = \pi^{-r(r+3)} D'_{k,\text{odd}} \quad \text{and} \quad c_{2r+4} = \pi^{-r(r+1)} D'_{k,\text{odd}}. \quad \square$$

Remark 8.5. Besides the case $k = 3$, in which $L_3(s) = L(\chi_3, s - 2)$ is a shifted Dirichlet L -function, Deligne’s conjecture holds for $k = 5, 6, 8$. In all three cases, $L_k(s)$ is the L -function of a modular form evaluated at $s - 2$ (see [Fresán et al. 2022, Table 1]) and the matrices in (8.3) have size one. The critical values have been expressed in terms of Bessel moments in [Bloch et al. 2015; Zhou 2018a; 2019b], thus confirming the conjecture. The first case where a true determinant is expected to occur is $L_7(5)$, which is a critical value of the L -function of the symmetric square of a modular form. Other numerical confirmations of Deligne’s conjecture for $k \leq 24$ appear in [Broadhurst and Roberts 2019].

Remark 8.6. Broadhurst and Roberts conjecture that, for $k \geq 12$ a multiple of 4, the L -function $L(M_k, s)$ always vanishes at the central point $s = \frac{1}{2}(k+2)$, even when the expected sign of the functional equation (see [Fresán et al. 2022, below Theorem 1.3]) is positive. According to Beilinson’s conjecture, this vanishing should be explained by the existence of certain nontrivial extension of M_k by $\mathbb{Q}(-k/2)$. It seems possible to construct such an extension by considering the quotient of the cohomology with compact support of $\text{Sym}^k \text{Kl}_2$ by its weight zero piece and to relate its nonsplitting to the shape of the full period matrix $P_k^{\text{mod,rd}}$ from Section 6. Indeed, suppose $4 \mid k$. The Nori motive $\tilde{M}_k = (H_c^{k-1}(\mathcal{X}_0)/W_0)^{\otimes_k \times \mu_2, \text{sgn}(-1)}$, where W_0 denotes the weight zero part, is an extension of M_k by a rank-one motive E of weight k . It has been shown in the proof of [loc. cit., Theorem 5.17] (see especially the discussion of the terms $(E_\infty^{1,k-2})_{\mathbb{F}_p}^{G,\chi}$ and $\ker(\beta)^{G,\chi}/W_0$) that as a representation of $\text{Gal}(\bar{\mathbb{Q}}_p/\mathbb{Q}_p)$, the ℓ -adic étale realization of E is isomorphic to $\mathbb{Q}_\ell(-k/2)$ for all primes $p \geq 3$ and $\ell \neq p$. Since the Frobenius elements of characteristic $p \geq 3$ are dense in $\text{Gal}(\bar{\mathbb{Q}}/\mathbb{Q})$, one obtains an isomorphism $E \simeq \mathbb{Q}(-k/2)$. From the viewpoint of the period realization, the nonsplitting of the extension \tilde{M}_k amounts to the claim that the entries of the last row of the period matrix $P_k^{\text{mod,rd}}$ span a \mathbb{Q} -space of dimension at least two in \mathbb{C} by Proposition 6.5(2). Concretely, the latter holds if and only if the moments $\text{BM}_k(k/2, 2j - 1)$ and $\text{BM}_k^{\text{reg}}(k/2, k' + 2j)$, for $1 \leq j < k/4$, are not all in $(2\pi i)^{k/2} \mathbb{Q}$ (rational multiples of the entry $P_{k;k/2,k/4}^{\text{mod,rd}}$). Such nonsplitting has been verified numerically for the period matrix P_k of $\tilde{M}_k^\vee(-k - 1)$ by Broadhurst and Roberts; see [Roberts 2017, Section 2].

Appendix: Period realization of an exponential mixed Hodge structure

by Claude Sabbah

This appendix can be regarded as a complement, with respect to period structures, to the appendix in [Fresán et al. 2022]. We consider the abelian category Per of *period structures*, whose objects consist of pairs $(V^\mathbb{C}, V_\mathbb{Q})$ consisting of a finite dimensional \mathbb{C} -vector space $V^\mathbb{C}$, a finite dimensional \mathbb{Q} -vector space $V_\mathbb{Q}$, together with an isomorphism

$$\text{comp} : \mathbb{C} \otimes_{\mathbb{Q}} V_\mathbb{Q} \xrightarrow{\sim} V^\mathbb{C}$$

and whose morphisms are the natural ones. There is a natural forgetful functor $\text{Per} : \text{MHS} \rightarrow \text{Per}$ from the category of \mathbb{Q} -mixed Hodge structures to that of period structures.

A1. The fiber period realization of an exponential mixed Hodge structure. Let X be a complex smooth quasiprojective variety and let N^H be an object of the abelian category $\text{MHM}(X)$ of \mathbb{Q} -mixed Hodge modules on X . It consists of a triple $((N, F^\bullet N), (\mathcal{F}_{\mathbb{Q}}, W_\bullet \mathcal{F}_{\mathbb{Q}}), \text{comp}_X)$, where

- $(N, F^\bullet N)$ is a holonomic \mathcal{D}_X -module endowed with a coherent filtration,
- $(\mathcal{F}_{\mathbb{Q}}, W_\bullet \mathcal{F}_{\mathbb{Q}})$ is a \mathbb{Q} -perverse sheaf on X^{an} endowed with an increasing filtration by \mathbb{Q} -perverse subsheaves,
- and the *comparison isomorphism* comp_X is an isomorphism $\mathbb{C} \otimes_{\mathbb{Q}} \mathcal{F}_{\mathbb{Q}} \xrightarrow{\sim} {}^p\text{DR } N$, where ${}^p\text{DR } N$ is the shifted de Rham complex $\text{DR } N[\dim X]$.

These data are subject to various compatibility relations that we do not make explicit here, referring to [Saito 1990; 2017] for details. From the mixed Hodge module N^H we only retain the triple $\text{Per}(N^H) := (N, \mathcal{F}_{\mathbb{Q}}, \text{comp}_X)$ by forgetting the Hodge and weight filtrations.

For example, let us consider the pure Hodge module ${}^p\mathbb{Q}_X^H$, with underlying \mathcal{D}_X -module equal to \mathcal{O}_X and underlying perverse sheaf ${}^p\mathbb{Q}_X = \mathbb{Q}_X[\dim X]$. The comparison isomorphism is induced by the isomorphism $\mathbb{C}_X = \mathcal{H}^0 \text{DR } \mathcal{O}_X \xrightarrow{\sim} \text{DR } \mathcal{O}_X$.

Let \mathbb{A}_θ^1 be the affine line with coordinate θ . The \mathbb{Q} -linear neutral Tannakian category EMHS (*exponential mixed Hodge structures*), as defined in [Kontsevich and Soibelman 2011, Section 4], is the full subcategory of $\text{MHM}(\mathbb{A}_\theta^1)$ consisting of objects N^H whose underlying perverse sheaf has vanishing global cohomology, with tensor structure given by the additive convolution \star . Denoting by $j : \mathbb{G}_m \rightarrow \mathbb{A}^1$ the inclusion, one defines a projector

$$\Pi : \text{MHM}(\mathbb{A}^1) \rightarrow \text{EMHS}, \quad N^H \mapsto N^H \star_{\mathbb{H}!} j^! {}^p\mathbb{Q}_{\mathbb{G}_m}^H,$$

consisting in neglecting constant mixed Hodge modules on \mathbb{A}^1 .

For an object N^H in EMHS, its *de Rham fiber* is the \mathbb{C} -vector space defined as

$$\text{H}_{\text{dR}}^1(\mathbb{A}_\theta^1, N \otimes E^\theta) = \text{H}^0 a_{\mathbb{A}_\theta^1, +} (N \otimes E^\theta),$$

where E^θ is the connection $(\mathcal{O}_{\mathbb{A}_\theta^1}, d + d\theta)$ and $a_{\mathbb{A}_\theta^1}$ denote the structure morphism of \mathbb{A}_θ^1 . This vector space is endowed with a filtration, called the irregular Hodge filtration; see [Fresán et al. 2022, Section A.3].

In order to define the Betti fiber functor, we consider the real oriented blowing-up $\varpi : \tilde{\mathbb{P}}^1 \rightarrow \mathbb{P}^1$ of \mathbb{P}^1 at ∞ and the open subset $\tilde{\mathbb{P}}_{\text{mod}}^1 = \mathbb{A}^{1, \text{an}} \cup \partial_{\text{mod}} \tilde{\mathbb{P}}^1$ in the neighborhood of which $e^{-\theta}$ has moderate growth, equivalently rapid decay, i.e., defined by $\text{Re}(\theta) > 0$. Let us denote the open inclusions $\mathbb{A}^{1, \text{an}} \hookrightarrow \tilde{\mathbb{P}}_{\text{mod}}^1$ and $\tilde{\mathbb{P}}_{\text{mod}}^1 \hookrightarrow \tilde{\mathbb{P}}^1$ respectively by α and β . The *Betti fiber* of N^H is defined as

$$\text{H}^0(\tilde{\mathbb{P}}^1, \beta_! R\alpha_* \mathcal{F}_{\mathbb{Q}}) = \text{H}_c^0(\tilde{\mathbb{P}}_{\text{mod}}^1, R\alpha_* \mathcal{F}_{\mathbb{Q}}).$$

Let us notice that these definitions can be extended to all objects N^H of $\text{MHM}(\mathbb{A}_\theta^1)$ and then the corresponding vector spaces only depend on $\Pi(N^H)$ since $\text{H}_{\text{dR}}^r(\mathbb{A}_\theta^1, E^\theta) = 0$ for all r .

In order to define the comparison isomorphism, we first recall that the de Rham fiber $\text{H}_{\text{dR}}^1(\mathbb{A}_\theta^1, N \otimes E^\theta)$ can be computed as the hypercohomology of the moderate de Rham complex $\text{DR}^{\text{mod}}(N \otimes E^\theta)$ on $\tilde{\mathbb{P}}^1$,

that there exists a canonical functorial isomorphism (see e.g., [Fresán et al. 2023, Section 2.e])

$$H_{\text{dR}}^1(\mathbb{A}_\theta^1, N \otimes E^\theta) \simeq H^0(\tilde{\mathbb{P}}^1, {}^p\text{DR}^{\text{mod}}(N \otimes E^\theta)). \quad (\text{A.1})$$

Furthermore:

Lemma A.2. *There exists a **unique** isomorphism*

$$\beta_! R\alpha_* \text{DR}^{\text{an}}(N) \simeq \text{DR}^{\text{mod}}(N \otimes E^\theta)$$

extending the identity on the analytic complex line $\mathbb{A}^{1\text{an}}$.

Proof. Indeed, let us recall (see [loc. cit.]) that $\text{DR}^{\text{mod}}(N \otimes E^\theta)$ has cohomology in degree zero only. Then one can easily show that its \mathcal{H}^0 is zero on the complement of $\tilde{\mathbb{P}}_{\text{mod}}^1$, so that the natural morphism

$$\beta_! \beta^{-1} \text{DR}^{\text{mod}}(N \otimes E^\theta) \rightarrow \text{DR}^{\text{mod}}(N \otimes E^\theta)$$

is an isomorphism. One then shows in the same way that

$$\beta^{-1} \text{DR}^{\text{mod}}(N \otimes E^\theta) = R\alpha_* \alpha^{-1} \beta^{-1} \text{DR}^{\text{mod}}(N \otimes E^\theta).$$

Uniqueness follows from the adjunction formulas [Kashiwara and Schapira 1990, (2.3.6) and (3.0.1)]. \square

On the other hand, termwise multiplication by $e^{-\theta}$ induces an isomorphism

$${}^p\text{DR}^{\text{an}}(N) \xrightarrow{\sim} {}^p\text{DR}^{\text{an}}(N \otimes E^\theta).$$

As a consequence, there exists a unique isomorphism

$$\text{comp}_{\tilde{\mathbb{P}}^1} : \beta_! R\alpha_* \mathcal{F}_{\mathbb{C}} \rightarrow {}^p\text{DR}^{\text{mod}}(N \otimes E^\theta)$$

extending $e^{-\theta} \circ \text{comp}_{\mathbb{A}^{1\text{an}}}$. This morphism is thus functorial with respect to N^{H} .

Definition A.3 (fiber period structure $\text{FPer}(N^{\text{H}})$). Let $N^{\text{H}} = (N, \mathcal{F}_{\mathbb{Q}}, \text{comp}_{\mathbb{A}^{1\text{an}}})$ be an object of EMHS:

(1) The *fiber comparison isomorphism*

$$\text{comp} : \mathbb{C} \otimes H^0(\tilde{\mathbb{P}}^1, \beta_! R\alpha_* \mathcal{F}_{\mathbb{Q}}) \rightarrow H_{\text{dR}}^1(\mathbb{A}_\theta^1, N \otimes E^\theta)$$

is the composition of $H^0(\tilde{\mathbb{P}}^1, \text{comp}_{\tilde{\mathbb{P}}^1})$ with that given by (A.1).

(2) The *fiber period structure* $\text{FPer}(N^{\text{H}})$ of an exponential mixed Hodge structure N^{H} is the following object of the category Per :

$$\text{FPer}(N^{\text{H}}) = (H_{\text{dR}}^1(\mathbb{A}_\theta^1, N \otimes E^\theta), H^0(\tilde{\mathbb{P}}^1, \beta_! R\alpha_* \mathcal{F}_{\mathbb{Q}}), \text{comp}).$$

In the following, we also regard FPer as a functor defined on $\text{MHM}(\mathbb{A}_\theta^1)$ by factorizing through EMHS by Π . The following lemma is then obvious.

Lemma A.4. *The assignment FPer defines an exact functor $\text{MHM}(\mathbb{A}_\theta^1) \rightarrow \text{Per}$ factoring through Π , and there is an isomorphism of functors to the category Per :*

$$\text{FPer}(N^{\text{H}}) \simeq (H^0(\tilde{\mathbb{P}}^1, \beta_! R\alpha_* {}^p\text{DR}^{\text{an}}(N \otimes E^\theta)), H^0(\tilde{\mathbb{P}}^1, \beta_! R\alpha_* \mathcal{F}_{\mathbb{Q}}), H^0(\tilde{\mathbb{P}}^1, \beta_! R\alpha_*(e^{-\theta} \circ \text{comp}_{\mathbb{A}^{1\text{an}}}))).$$

On the other hand, let $i_0 : \{0\} \hookrightarrow \mathbb{A}^1$ be the closed embedding. The abelian category $\text{MHS} = \text{MHM}(\{0\})$ of mixed Hodge structures is identified with a full subcategory of $\text{MHM}(\mathbb{A}^1)$ and of EMHS via the pushforward ${}_{\text{H}}i_{0!}$ of mixed Hodge modules and the composition $\Pi \circ {}_{\text{H}}i_{0!}$, respectively.

Proposition A.5. *There is a commutative diagram of functors:*

$$\begin{array}{ccc}
 \text{MHS} & \xrightarrow{\Pi \circ {}_{\text{H}}i_{0!}} & \text{EMHS} \\
 \text{Per} \downarrow & & \swarrow \text{FPer} \\
 & & \text{Per}
 \end{array}$$

Proof. This follows from the tautological identification for a vector space V over either \mathbb{Q} or \mathbb{C}

$$\text{H}_{\mathbb{C}}^0(\widetilde{\mathbb{P}}_{\text{mod}}^1, R\alpha_* Ri_{0!}V) = V,$$

which commutes with change of base field. □

A2. Computation of the fiber comparison isomorphism for a Gauss–Manin exponential mixed Hodge structure. Let $f : X \rightarrow \mathbb{A}_{\theta}^1$ be a projective morphism from a smooth quasiprojective variety X to the affine line \mathbb{A}_{θ}^1 . We denote the pushforward functor $\text{D}^b(\text{MHM}(X)) \rightarrow \text{D}^b(\text{MHM}(\mathbb{A}_{\theta}^1))$ by ${}_{\text{H}}f_*$; see [Saito 1990, Theorem 4.3]. For each object N^{H} of $\text{MHM}(X)$ and each integer r , we consider the mixed Hodge module $\mathcal{H}^r {}_{\text{H}}f_* N^{\text{H}}$ that we simply denote by ${}_{\text{H}}f_*^r N^{\text{H}}$. We will compute its fiber period structure by means of cohomology on a suitable real blow-up space.

For that purpose, consider a smooth projective compactification $\bar{f} : \bar{X} \rightarrow \mathbb{P}^1$ of X and f giving rise to a commutative diagram

$$\begin{array}{ccc}
 X & \xrightarrow{j} & \bar{X} \\
 f \downarrow & & \downarrow \bar{f} \\
 \mathbb{A}_{\theta}^1 & \xrightarrow{\quad} & \mathbb{P}^1
 \end{array}$$

such that the pole divisor $P = \bar{f}^{-1}(\infty)$ is a strict normal crossing divisor in \bar{X} . We denote by $\varpi : \tilde{X}(P) \rightarrow \bar{X}$ the real-oriented blowing-up of \bar{X} along the irreducible components of P . Then \bar{f} lifts as a real-analytic morphism $\tilde{f} : \tilde{X}(P) \rightarrow \tilde{\mathbb{P}}^1$. In this section, we set $\tilde{X} = \tilde{X}(P)$. We define the open subset $\partial_{\text{mod}}\tilde{X}$ of $\partial\tilde{X} = \varpi^{-1}(P)$ as consisting of points of $\varpi^{-1}(P)$ in the neighborhood of which e^{-f} has moderate growth — equivalently, rapid decay — so that $\partial_{\text{mod}}\tilde{X} = \tilde{f}^{-1}(\partial_{\text{mod}}\tilde{\mathbb{P}}^1)$. The subset

$$\tilde{X}_{\text{mod}} := X \cup \partial_{\text{mod}}\tilde{X} = \tilde{f}^{-1}(\tilde{\mathbb{P}}_{\text{mod}}^1)$$

is open in \tilde{X} . We also denote by α, β the respective open inclusions

$$X \xrightarrow{\alpha} \tilde{X}_{\text{mod}} \xrightarrow{\beta} \tilde{X}.$$

As in [Section 2.1](#), we set $E^f = (\mathcal{O}_X, d + df)$ and, for a \mathcal{D}_X -module N regarded as an \mathcal{O}_X -module with flat connection ∇ , we set $N \otimes E^f = (N, \nabla + df)$. To a mixed Hodge module N^H on X we associate a period structure in Per as follows. The vector spaces are (the perverse convention is used here)

$$\begin{aligned} {}^p\text{H}_{\text{dR}}^r(X, N \otimes E^f) &:= \text{H}^r(X, {}^p\text{DR}_X(N \otimes E^f)), \\ {}^p\text{H}_{\text{B}}^r(X, \mathcal{F}_{\mathbb{Q}} \otimes E^f) &:= \text{H}^r(\tilde{X}, \beta_! R\alpha_* \mathcal{F}_{\mathbb{Q}}) = \text{H}_{\mathbb{C}}^r(\tilde{X}_{\text{mod}}, R\alpha_* \mathcal{F}_{\mathbb{Q}}). \end{aligned}$$

In order to make the comparison isomorphism explicit, we need the following proposition. We note that termwise multiplication by the holomorphic function e^{-f} induces an isomorphism ${}^p\text{DR}_X^{\text{an}} N \xrightarrow{\sim} {}^p\text{DR}_X^{\text{an}}(N \otimes E^f)$. On the other hand, we endow \tilde{X} with the sheaf $\mathcal{S}_{\tilde{X}}^{\text{mod}}$ of holomorphic functions on X having moderate growth along $\partial\tilde{X}$. Then any \mathcal{D}_X -module M has a (shifted) moderate de Rham complex ${}^p\text{DR}_{\tilde{X}}^{\text{mod}} M$ on \tilde{X} ; see e.g., [[Fresán et al. 2023](#), Section 2.e]. We also denote by $j : X \rightarrow \tilde{X}$ the inclusion.

Proposition A.6. *For a regular holonomic \mathcal{D}_X -module N , the following two natural morphisms*

$$\begin{aligned} \beta_! \beta^{-1} {}^p\text{DR}_{\tilde{X}}^{\text{mod}} j_+(N \otimes E^f) &\rightarrow {}^p\text{DR}_{\tilde{X}}^{\text{mod}} j_+(N \otimes E^f), \\ \beta^{-1} {}^p\text{DR}_{\tilde{X}}^{\text{mod}} j_+(N \otimes E^f) &\rightarrow R\alpha_* \alpha^{-1} \beta^{-1} {}^p\text{DR}_{\tilde{X}}^{\text{mod}} j_+(N \otimes E^f) \end{aligned}$$

are quasiisomorphisms.

Sketch of proof. A similar result is proved in [[Sabbah 1996](#)] (proof of Theorem 5.1) but the definition of the sheaf of functions with moderate growth used there is more restrictive than the one needed for our purposes. Instead, one uses computations similar to those of [[Hien 2007](#), Proposition 3.3] (see also [[Hien 2009](#), Proposition 1]) together with [[Mochizuki 2014](#), Corollary 4.7.3]. \square

We conclude that there is a natural isomorphism

$$\beta_! R\alpha_* {}^p\text{DR}_X^{\text{an}}(N \otimes E^f) \xrightarrow{\sim} {}^p\text{DR}_{\tilde{X}}^{\text{mod}} j_+(N \otimes E^f) \quad (\text{A.7})$$

in the derived category $\text{D}^b(\mathbb{C}_{\tilde{X}})$, which is functorial with respect to N . Moreover, by the arguments of adjunction already used in the proof of [Lemma A.2](#), this is the unique isomorphism extending the identity on X .

Corollary A.8. *For a mixed Hodge module $N^H \in \text{MHM}(X)$ there exists a unique isomorphism*

$$\text{comp}_{\tilde{X}} : \beta_! R\alpha_* \mathcal{F}_{\mathbb{C}} \rightarrow {}^p\text{DR}_{\tilde{X}}^{\text{mod}} j_+(N \otimes E^f)$$

which extends $e^{-f} \circ \text{comp}_X : \mathcal{F}_{\mathbb{C}} \rightarrow {}^p\text{DR}_X^{\text{an}}(N \otimes E^f)$. We have

$$\text{comp}_{\tilde{X}} = (\text{A.7}) \circ \beta_! R\alpha_*(e^{-f} \circ \text{comp}_X).$$

This morphism is functorial on $\text{MHM}(X)$. \square

In a way similar to [\(A.1\)](#), one shows that, for any r , there exists a canonical isomorphism

$$\begin{aligned} \text{can}_r : \text{H}^r(\tilde{X}, {}^p\text{DR}_{\tilde{X}}^{\text{mod}} j_+(N \otimes E^f)) &\simeq \text{H}^r(\bar{X}, {}^p\text{DR}_{\bar{X}} j_+(N \otimes E^f)) \\ &= \text{H}^r(X, {}^p\text{DR}_X(N \otimes E^f)) =: {}^p\text{H}_{\text{dR}}^r(X, N \otimes E^f). \end{aligned}$$

Definition A.9. Let N^H be an object of $\text{MHM}(X)$. For each r (the perverse convention is used here), the fiber period structure $\text{FPer}^r(N^H \otimes E^f)$ is defined as

$$\text{FPer}^r(N^H \otimes E^f) = ({}^p\text{H}_{\text{dR}}^r(X, N \otimes E^f), \text{H}_{\mathbb{B}}^r(X, \mathcal{F}_{\mathbb{Q}} \otimes E^f), \text{can}_r \circ {}^p\text{H}^r(\tilde{X}, \text{comp}_{\tilde{X}})).$$

Lemma A.10 (expression of $\text{FPer}^r(N^H \otimes E^f)$ on the real blow-up). *For each r , there is an isomorphism in Per :*

$$\text{FPer}^r(N^H \otimes E^f) \simeq (\text{H}^r(\tilde{X}, \beta_! R\alpha_* {}^p\text{DR}_X^{\text{an}} j_+(N \otimes E^f)v), \text{H}^r(\tilde{X}, \beta_! R\alpha_* \mathcal{F}_{\mathbb{Q}}), \text{H}^r(\tilde{X}, \beta_! R\alpha_*(e^{-f} \circ \text{comp}_X))).$$

Proof. The isomorphism is the identity on the middle term and the isomorphism on the left term is given by $\text{can}_r \circ \text{H}^r(\tilde{X}, \text{(A.7)})$. □

We then deduce that the fiber period structure $\text{FPer}^r(N^H \otimes E^f)$ is isomorphic to that attached to the exponential mixed Hodge structure $\Pi({}_H f_*^r N^H)$:

Proposition A.11. *For each r , there is a functorial isomorphism of fiber period structures:*

$$\text{FPer}({}_H f_*^r N^H) \simeq \text{FPer}^r(N^H \otimes E^f).$$

Proof. By definition, the comparison isomorphism $\text{comp}_{\mathbb{A}_\theta^1}$ for ${}_H f_*^j N^H$ is obtained by taking the j -th perverse cohomology of the composed isomorphism

$$Rf_* \mathcal{F}_{\mathbb{C}} \xrightarrow{Rf_* \text{comp}_X} Rf_* {}^p\text{DR}^{\text{an}} N \xrightarrow{\sim} {}^p\text{DR}^{\text{an}} f_+ N,$$

where the second morphism is the standard functorial isomorphism from \mathcal{D} -module theory. We also have a commutative diagram:

$$\begin{array}{ccc} Rf_* {}^p\text{DR}^{\text{an}} N & \longrightarrow & {}^p\text{DR}^{\text{an}} f_+ N \\ Rf_* e^{-f} \downarrow & & \downarrow e^{-\theta} \\ Rf_* {}^p\text{DR}^{\text{an}}(N \otimes E^f) & \longrightarrow & {}^p\text{DR}^{\text{an}}((f_+ N) \otimes E^\theta) \end{array}$$

We now take the models of Lemmas A.4 and A.10 and the desired isomorphism is obtained (after applying $R\Gamma(\tilde{\mathbb{P}}^1, \cdot)$ and taking cohomology) from the canonical isomorphism of functors

$$R\tilde{f}_* \circ \beta_! R\alpha_* \simeq \beta_! R\alpha_* Rf_*$$

from $\text{D}^b(\mathbb{C}_X)$ to $\text{D}^b(\mathbb{C}_{\tilde{\mathbb{P}}^1})$, that we recall now. We consider the two commutative squares:

$$\begin{array}{ccccc} X & \xrightarrow{\alpha} & \tilde{X}_{\text{mod}} & \xrightarrow{\beta} & \tilde{X} \\ f \downarrow & & \downarrow \tilde{f}_{\text{mod}} & & \downarrow \tilde{f} \\ \mathbb{A}_\theta^1 & \xrightarrow{\alpha} & \tilde{\mathbb{P}}_{\text{mod}}^1 & \xrightarrow{\beta} & \tilde{\mathbb{P}}^1 \end{array}$$

Since \tilde{f} is proper, we have a canonical isomorphism of functors $R\tilde{f}_* \circ \beta_! \simeq \beta_! \circ R\tilde{f}_{\text{mod}*}$, and on the other hand we have $R\tilde{f}_{\text{mod}*} \circ R\alpha_* \simeq R\alpha_* \circ R\tilde{f}_*$. □

A3. Fiber period realization of a pair (U, f) .

Application of the results of Section A2. Let U be a smooth complex quasiprojective variety of dimension d and let $f : U \rightarrow \mathbb{A}_\theta^1$ be a regular function. Starting with the mixed Hodge module ${}^p\mathbb{Q}_U^H$, we aim at giving a formula for the fiber period structure of the exponential mixed Hodge structures associated with the pushforward mixed Hodge modules ${}_{\mathbb{H}}f_*^r {}^p\mathbb{Q}_U^H$ and ${}_{\mathbb{H}}f_!^r {}^p\mathbb{Q}_U^H$ ($r \in \mathbb{Z}$). For that purpose, it is convenient to choose a partial completion $\kappa : U \hookrightarrow X$ of U as a smooth quasiprojective variety X so that $H = X \setminus U$ is a strict normal crossing divisor and that f extends as a projective morphism $f : X \rightarrow \mathbb{A}_\theta^1$. The result will be independent of such a choice. The commutative diagram used in Section A2 is thus completed on the left as follows:

$$\begin{array}{ccccc} U & \xhookrightarrow{\kappa} & X & \xhookrightarrow{j} & \bar{X} \\ f \downarrow & & \downarrow f & & \downarrow \bar{f} \\ \mathbb{A}_\theta^1 & \xlongequal{\quad} & \mathbb{A}_\theta^1 & \xhookrightarrow{\quad} & \mathbb{P}^1 \end{array}$$

We consider the objects N^H of $\text{MHM}(X)$ defined as $N^H = {}_{\mathbb{H}}\kappa_* {}^p\mathbb{Q}_U^H$ or $N^H = {}_{\mathbb{H}}\kappa_! {}^p\mathbb{Q}_U^H$. Correspondingly, we write $N \otimes E^f$ as $E^f(*H)$ or $E^f(!H)$ and we have $\mathcal{F}_{\mathbb{Q}} = R\kappa_* {}^p\mathbb{Q}_U$ or $R\kappa_! {}^p\mathbb{Q}_U$. In this way, we are in the setting of Section A2.

We denote respectively by $H^r(U, f)$ and $H_c^r(U, f)$ the exponential mixed Hodge structure $\Pi({}_{\mathbb{H}}f_*^{r-d} {}^p\mathbb{Q}_U^H)$ and $\Pi({}_{\mathbb{H}}f_!^{r-d} {}^p\mathbb{Q}_U^H)$, and

$$H_{\text{mid}}^r(U, f) = \text{im}[H_c^r(U, f) \rightarrow H^r(U, f)]. \tag{A.12}$$

We denote respectively the associated de Rham fibers by $H_{\text{dR}}^r(U, f)$ and $H_{\text{dR},c}^r(U, f)$, and the Betti fibers by $H_{\mathbb{B}}^r(U, f)$ and $H_{\mathbb{B},c}^r(U, f)$. We then have

$$H_{\text{dR}}^r(U, f) \simeq H^r(X, \text{DR}(E^f(*H))), \quad H_{\text{dR},c}^r(U, f) \simeq H^r(X, \text{DR}(E^f(!H))).$$

Keeping the notation of Section A2 for α, β (and emphasizing now the divisor P), we have by Proposition A.11

$$H_{\mathbb{B}}^r(U, f) = H^r(\tilde{X}(P), \beta_! R\alpha_* R\kappa_* \mathbb{Q}_U), \quad H_{\mathbb{B},c}^r(U, f) = H^r(\tilde{X}(P), \beta_! R\alpha_* R\kappa_! \mathbb{Q}_U).$$

We set $\tilde{U}_{\text{mod}}(P) = \tilde{X}_{\text{mod}}(P) \setminus \varpi^{-1}(H)$ and we denote by Φ the family of closed subsets of $\tilde{U}_{\text{mod}}(P)$ whose closure in \tilde{X} is contained in the open subset $\tilde{X}_{\text{mod}}(P)$.

Proposition A.13. *We have*

$$H_{\mathbb{B}}^r(U, f) \simeq H_{\Phi}^r(\tilde{U}_{\text{mod}}(P), \mathbb{Q}) \quad \text{and} \quad H_{\mathbb{B},c}^r(U, f) \simeq H_c^r(\tilde{U}_{\text{mod}}(P), \mathbb{Q}),$$

and the natural morphism $H_{\mathbb{B},c}^r(U, f) \rightarrow H_{\mathbb{B}}^r(U, f)$ is induced by the inclusion of the families of supports.

Remark A.14. Setting $\tilde{U}(P) = \tilde{X}(P) \setminus \varpi^{-1}(H)$ and denoting by $\partial_{\text{exp}} \tilde{X}(P)$, respectively $\partial_{\text{exp}} \tilde{U}(P)$, the closed subset complement to $\tilde{X}_{\text{mod}}(P)$ in $\tilde{X}(P)$, respectively to $\tilde{U}_{\text{mod}}(P)$ in $\tilde{U}(P)$, the spaces $H_{\mathbb{B}}^r(U, f)$

and $H_{B,c}^r(U, f)$ also read in terms of relative cohomology

$$H_{B,c}^r(U, f) \simeq H^r(\tilde{U}(P), \partial_{\text{exp}} \tilde{U}(P), \mathbb{Q}), \quad H_{B,c}^r(U, f) \simeq H^r(\tilde{X}(P), \partial_{\text{exp}} \tilde{X}(P) \cup \varpi^{-1}(H), \mathbb{Q}),$$

and the natural morphism between both is induced by the inclusion of pairs $(\tilde{U}(P), \partial_{\text{exp}} \tilde{U}(P)) \hookrightarrow (\tilde{X}(P), \partial_{\text{exp}} \tilde{X}(P))$, so that $H_{B,\text{mid}}^r(U, f)$ is the corresponding image, according to (A.12).

Proof of Proposition A.13. In the proof, we simply set $\tilde{X} = \tilde{X}(P)$. With the notation above, we consider the commutative diagram

$$\begin{array}{ccccccc} U & \xrightarrow{\alpha_U} & \tilde{U}_{\text{mod}} & \xrightarrow{\beta_U} & \tilde{U} & \xleftarrow{\gamma_U} & \partial_{\text{exp}} \tilde{U} \\ \downarrow \kappa & & \downarrow \tilde{\kappa}' & & \downarrow \tilde{\kappa} & & \downarrow \\ X & \xrightarrow{\alpha} & \tilde{X}_{\text{mod}} & \xrightarrow{\beta} & \tilde{X} & \xleftarrow{\gamma} & \partial_{\text{exp}} \tilde{X} \end{array}$$

where the first line is obtained from the second one by deleting $\varpi^{-1}(H)$.

For the identification of $H_{B,c}^r(U, f)$, we need the next lemma.

Lemma A.15. *For $\star = *$ or $\star = !$, there is an isomorphism in $D^b(\tilde{X}, \mathbb{Q})$*

$$R\tilde{\kappa}_\star \beta_{U!} R\alpha_{U*} \mathbb{Q}_U \simeq \beta_! R\alpha_* R\kappa_\star \mathbb{Q}_U.$$

Proof. We can replace $R\alpha_* R\kappa_\star$ with $R\tilde{\kappa}'_\star R\alpha_{U*}$. Furthermore, a local computation shows that

$$R\alpha_{U*} \mathbb{Q}_U = \mathbb{Q}_{\tilde{U}_{\text{mod}}} = \beta_U^{-1} \mathbb{Q}_{\tilde{U}} \quad \text{and} \quad (R\beta_U \circ R\alpha_U)_* \mathbb{Q}_U = \mathbb{Q}_{\tilde{U}}.$$

We are thus reduced to finding an isomorphism $R\tilde{\kappa}_\star \beta_{U!} \mathbb{Q}_{\tilde{U}_{\text{mod}}} \simeq \beta_! R\tilde{\kappa}'_\star \mathbb{Q}_{\tilde{U}_{\text{mod}}}$. Let us first construct a morphism. There is a natural morphism

$$R\tilde{\kappa}_\star \beta_{U!} \mathbb{Q}_{\tilde{U}_{\text{mod}}} \rightarrow R\tilde{\kappa}_\star R\beta_{U*} \mathbb{Q}_{\tilde{U}_{\text{mod}}} \simeq R\beta_* R\tilde{\kappa}'_\star \mathbb{Q}_{\tilde{U}_{\text{mod}}}$$

and this morphism can be lifted as a morphism to $\beta_! R\tilde{\kappa}'_\star \mathbb{Q}_{\tilde{U}_{\text{mod}}}$ if and only if its restriction by γ is zero. Clearly, $\gamma^{-1} R\tilde{\kappa}_\star \beta_{U!} \mathbb{Q}_{\tilde{U}_{\text{mod}}}$ is zero on $\partial_{\text{exp}} \tilde{U}$ and we need to check that the same property holds true on $\varpi^{-1}(H) \cap \partial_{\text{exp}} \tilde{X}$. The question reduces to a local computation in the neighborhood of each point of $P \cap H$ in \tilde{X} . We thus work in an adapted coordinate neighborhood Δ^d of such a point. We can write $\Delta^d = \Delta^\ell \times \Delta^{d-\ell}$, with $P \cap \Delta^d = P' \times \Delta^{d-\ell}$ defined by the vanishing of the product of coordinates in Δ^ℓ and $H \cap \Delta^d = \Delta^\ell \times H''$ defined by the vanishing of the product of some coordinates in $\Delta^{d-\ell}$. In this model, the real blowing-up $\varpi : \tilde{\Delta}^\ell \times \Delta^{d-\ell} \rightarrow \Delta^\ell \times \Delta^{d-\ell}$ is induced by the real blowing-up of Δ^ℓ along its coordinates hyperplanes. In restriction to this chart we have $U = \Delta^\ell \times (\Delta^{d-\ell} \setminus H'')$ and

$$\begin{aligned} \tilde{X}_{\text{mod}} &= (\tilde{\Delta}^\ell)_{\text{mod}} \times \Delta^{d-\ell}, & \tilde{U}_{\text{mod}} &= (\tilde{\Delta}^\ell)_{\text{mod}} \times (\Delta^{d-\ell} \setminus H''), \\ \partial_{\text{exp}} \tilde{X} &= \partial_{\text{exp}} (\tilde{\Delta}^\ell) \times \Delta^{d-\ell}, & \partial_{\text{exp}} \tilde{U} &= \partial_{\text{exp}} (\tilde{\Delta}^\ell) \times (\Delta^{d-\ell} \setminus H''). \end{aligned} \tag{A.16}$$

The assertion is then clear since the morphisms β_U and $\tilde{\kappa}$ act on disjoint sets of variables. With the same local computation, one checks that the morphism thus obtained is an isomorphism. \square

We can now conclude the proof for $H_B^r(U, f)$. From the previous lemma with $\star = *$ we deduce

$$H^r(\tilde{X}, \beta_! R\alpha_* R\kappa_* \mathbb{Q}_U) \simeq H^r(\tilde{X}, R\tilde{\kappa}_* \beta_{U!} R\alpha_{U*} \mathbb{Q}_U) = H^r(\tilde{U}, \beta_{U!} \mathbb{Q}_{\tilde{\text{mod}}}),$$

and the assertion is then clear. On the other hand, the distinguished triangle in $D^b(\tilde{U}, \mathbb{Q})$

$$\beta_{U!} \beta_U^{-1} \mathbb{Q}_{\tilde{U}} \rightarrow \mathbb{Q}_{\tilde{U}} \rightarrow R\gamma_{U*} \gamma_U^{-1} \mathbb{Q}_{\tilde{U}} \xrightarrow{+1}$$

gives the expression of $H_B^r(U, f)$ in terms of relative cohomology as asserted in [Remark A.14](#).

For $H_{B,c}^r(U, f)$, the previous lemma with $\star = !$ gives similarly

$$H^r(\tilde{X}, \beta_! R\alpha_* \kappa_! \mathbb{Q}_U) \simeq H^r(\tilde{X}, (\tilde{\kappa} \circ \beta_U)_! R\alpha_{U*} \mathbb{Q}_U) = H_c^r(\tilde{\text{mod}}, \mathbb{Q}). \quad \square$$

Remark A.17. Let $Z \subset U$ be a divisor on which f vanishes, let a_Z denote the structure morphism, let $i_Z: Z \hookrightarrow U$ denote the closed inclusion and $j_Z: U \setminus Z \hookrightarrow U$ the complementary open inclusion. We set ${}^p\mathbb{Q}_Z^H = {}_H a_Z^* \mathbb{Q}_{\text{Spec } \mathbb{C}}^H[\dim Z]$, so that there is an isomorphism

$${}_{H!} i_Z^* {}^p\mathbb{Q}_U^H = \mathcal{H}^0 {}_{H!} i_Z^* {}^p\mathbb{Q}_U^H \simeq {}^p\mathbb{Q}_Z^H$$

and an exact sequence

$$0 \rightarrow {}_{H!} i_Z^* {}^p\mathbb{Q}_Z^H \rightarrow {}_{H!} j_Z^* {}^p\mathbb{Q}_U^H \rightarrow {}^p\mathbb{Q}_U^H \rightarrow 0,$$

giving rise to an exact sequence in EMHS, see [\[Fresán et al. 2022, \(A.21\)\]](#),

$$\dots \rightarrow H_c^{r-1}(Z) \rightarrow H_c^r(U \setminus Z, f) \rightarrow H_c^r(U, f) \rightarrow H_c^r(Z) \rightarrow \dots$$

If $H_c^r(U \setminus Z, f) = 0$ for each r , the exponential mixed Hodge structure $H_c^r(U, f)$ is isomorphic to the mixed Hodge structure $H_c^r(Z)$ and, correspondingly, the fiber period structure $\text{FPer}(H_c^r(U, f))$ is isomorphic to $\text{Per}(H_c^r(Z))$. We will make explicit this exact sequence for the Betti fibers. Since $\bar{f}: \bar{X} \rightarrow \mathbb{P}^1$ is a morphism, we have $\bar{Z} \cap P = \emptyset$. We have a distinguished triangle

$$\beta_! R\alpha_* Ri_{Z*} \mathbb{Q}_Z \rightarrow \beta_! R\alpha_* j_{Z!} \mathbb{Q}_{U \setminus Z} \rightarrow \beta_! R\alpha_* \mathbb{Q}_U \xrightarrow{+1}$$

and since the closure of Z in $\tilde{X}(P)$ does not intersect $\partial \tilde{X}(P)$, we find

$$\beta_! R\alpha_* Ri_{Z*} \mathbb{Q}_Z = \beta_! R\alpha_* Ri_{Z*} \mathbb{Q}_Z \quad \text{and} \quad \beta_! R\alpha_* j_{Z!} \mathbb{Q}_{U \setminus Z} = \beta_{Z!} \mathbb{Q}_{\tilde{\text{mod}}(P) \setminus Z},$$

where β_Z is the inclusion $\tilde{\text{mod}}(P) \setminus Z \hookrightarrow \tilde{X}(P)$. The Betti exact sequence reduces then to

$$\dots \rightarrow H_c^{r-1}(Z, \mathbb{Q}) \rightarrow H_c^r(\tilde{\text{mod}}(P) \setminus Z, \mathbb{Q}) \rightarrow H_c^r(\tilde{\text{mod}}(P), \mathbb{Q}) \rightarrow H_c^r(Z, \mathbb{Q}) \rightarrow \dots \quad (\text{A.18})$$

Computation with the total real blow-up. In order to use results of [\[Fresán et al. 2023\]](#), we consider the real blowing-up $\pi: \tilde{X}(D) \rightarrow \bar{X}$ of the irreducible components of $D = P \cup H$ in \bar{X} . There is a natural morphism $\tilde{\omega}: \tilde{X}(D) \rightarrow \tilde{X}(P)$, so that $\pi = \tilde{\omega} \circ \tilde{\omega}$. In a local chart where formulas [\(A.16\)](#) hold, $\tilde{\omega}$ is the blowing-up map of the components of H'' in $\Delta^{d-\ell}$:

$$\tilde{X}(D) = \tilde{\Delta}^\ell \times \tilde{\Delta}^{d-\ell} \rightarrow \tilde{\Delta}^\ell \times \Delta^{d-\ell} = \tilde{X}(P).$$

We consider the open subsets $\tilde{U}_{\text{mod}}(D) = U \cup \partial_{\text{mod}}\tilde{X}(D)$ and $\tilde{U}_{\text{rd}}(D) = U \cup \partial_{\text{rd}}\tilde{X}(D)$, where:

- $\partial_{\text{mod}}\tilde{X}(D)$ is the open subset of $\pi^{-1}(D)$ in the neighborhood of which e^{-f} has moderate growth (it contains $\pi^{-1}(D \setminus P)$).
- $\partial_{\text{rd}}\tilde{X}(D)$ is the open subset of $\pi^{-1}(P)$ in the neighborhood of which e^{-f} has moderate growth, equivalently, rapid decay.

In the local chart as above, these sets read

$$\tilde{U}_{\text{mod}}(D) = (\tilde{\Delta}^\ell)_{\text{mod}} \times \tilde{\Delta}^{d-\ell}, \quad \tilde{U}_{\text{rd}}(D) = (\tilde{\Delta}^\ell)_{\text{mod}} \times (\Delta^{d-\ell} \setminus H'').$$

For the sake of simplicity, we denote by $\mathbb{Q}_{\tilde{U}_{\text{mod}}(D)}$ the sheaf on $\tilde{X}(D)$ which is the extension by zero of the constant sheaf on $\tilde{U}_{\text{mod}}(D)$ with stalk \mathbb{Q} (notation of [Kashiwara and Schapira 1990]), and similarly with rd. From the previous identifications with now $\alpha : X \hookrightarrow \tilde{X}_{\text{mod}}(D)$ and $\beta : \tilde{X}_{\text{mod}}(D) \hookrightarrow \tilde{X}(D)$, we obtain

$$R\tilde{\omega}_* \mathbb{Q}_{\tilde{U}_{\text{mod}}(D)} = \beta_! R\alpha_* R\kappa_* \mathbb{Q}_U, \quad R\tilde{\omega}_* \mathbb{Q}_{\tilde{U}_{\text{rd}}(D)} = \mathbb{Q}_{\tilde{U}_{\text{mod}}(P)}$$

(in fact $\tilde{\omega} : \tilde{U}_{\text{rd}}(D) \rightarrow \tilde{U}_{\text{mod}}(P)$ is an isomorphism). Therefore,

$$H_{\mathbb{B}}^r(U, f) \simeq H_{\mathbb{C}}^r(\tilde{U}_{\text{mod}}(D), \mathbb{Q}) \quad \text{and} \quad H_{\mathbb{B},\mathbb{C}}^r(U, f) \simeq H_{\mathbb{C}}^r(\tilde{U}_{\text{rd}}(D), \mathbb{Q}). \quad (\text{A.19})$$

Let Φ_{rd} (resp. Φ_{mod}) denote the family of closed subsets F of U whose (compact) closure \bar{F} in $\tilde{X}(D)$ is contained in $\tilde{U}_{\text{rd}}(D)$ (resp. $\tilde{U}_{\text{mod}}(D)$). A closed set F of U belongs to Φ_{rd} (resp. Φ_{mod}) if and only if $|\exp(-f)|_F$ tends to zero faster than any positive power of $\text{dist}(x, x_o)$ (resp. is bounded by some negative power of $\text{dist}(x, x_o)$) when $x \in F$ tends to some $x_o \in D$. Then the right-hand sides in (A.19) read

$$H_{\mathbb{C}}^r(\tilde{U}_{\text{mod}}(D), \mathbb{Q}) = H_{\Phi_{\text{mod}}}^r(U, \mathbb{Q}), \quad H_{\mathbb{C}}^r(\tilde{U}_{\text{rd}}(D), \mathbb{Q}) = H_{\Phi_{\text{rd}}}^r(U, \mathbb{Q}), \quad (\text{A.20})$$

and, by considering the natural morphism induced by the inclusion of family of supports, we have

$$H_{\mathbb{B},\text{mid}}^r(U, f) = \text{im}[H_{\Phi_{\text{rd}}}^r(U, \mathbb{Q}) \rightarrow H_{\Phi_{\text{mod}}}^r(U, \mathbb{Q})]. \quad (\text{A.21})$$

Rapid decay and moderate growth homology spaces for the pair (U, f) . If $\mathbf{1}$ denotes the generator of $E^f = (\mathcal{O}_U, d + df)$, then $\exp(-f) \cdot \mathbf{1}$ is an analytic flat section of E^f . The moderate growth and the rapid decay homology spaces of the pair (U, f) , as defined in [Fresán et al. 2023], are the homology of the chain complexes consisting of singular chains in $\tilde{X}(D)$ with boundary in $\partial\tilde{X}(D)$ twisted by the flat section $\exp(-f) \cdot \mathbf{1}$, whose support is contained in $\tilde{U}_{\text{mod}}(D)$ and $\tilde{U}_{\text{rd}}(D)$, respectively. The flat section being fixed, we get identifications with relative homology spaces

$$H_r^{\text{mod}}(U, f) \simeq H_r(\tilde{U}_{\text{mod}}(D), \partial\tilde{U}_{\text{mod}}(D), \mathbb{Q}) \quad \text{and} \quad H_r^{\text{rd}}(U, f) \simeq H_r(\tilde{U}_{\text{rd}}(D), \partial\tilde{U}_{\text{rd}}(D), \mathbb{Q}). \quad (\text{A.22})$$

Notation A.23. For the sake of simplicity, we omit the flat section $\exp(-f) \cdot \mathbf{1}$ in the notation of such twisted chains, that we simply call respectively rapid decay and moderate chains (we will not make use of the latter).

We have a more explicit expression of the rapid decay homology as follows. By suitably lifting to $\tilde{X}(D)$ the radial vector field of length one centered at $\infty \in \mathbb{P}^1$ so that it remains tangent to $\pi^{-1}(D \setminus P)$, and by following its flow, we obtain for every large enough $R > 0$ a deformation retraction of the pair $(\tilde{U}_{\text{rd}}(D), \partial_R \tilde{U}_{\text{rd}}(D))$ to the pair $(\tilde{U}_{\text{rd}}(D), \partial \tilde{U}_{\text{rd}}(D))$, where the thickened boundary $\partial_R \tilde{U}_{\text{rd}}(D)$ is defined as $\tilde{U}_{\text{rd}}(D) \cap \{|f| \geq R\} \cap \{\text{Re}(f) > 0\}$. Setting

$$\partial_{\text{rd},R} U = U \cap \partial_R \tilde{U}_{\text{rd}}(D) = U \cap \{|f| \geq R\} \cap \{\text{Re}(f) > 0\}, \quad R \gg 0,$$

by excision of $\partial \tilde{U}_{\text{rd}}(D)$, we obtain (for $R \gg 0$)

$$H_r^{\text{rd}}(U, f) \simeq H_r(\tilde{U}_{\text{rd}}(D), \partial \tilde{U}_{\text{rd}}(D), \mathbb{Q}) \simeq H_r(\tilde{U}_{\text{rd}}(D), \partial_R \tilde{U}_{\text{rd}}(D), \mathbb{Q}) \simeq H_r(U, \partial_{\text{rd},R} U, \mathbb{Q}). \quad (\text{A.24})$$

Remark A.25 (period pairing and period realization). Working with the transposed period structures as in [Fresán et al. 2023, Proposition 2.28], and considering rapid decay and moderate growth homology, one can show that there exist isomorphisms of (the transposes of) period structures

$$\begin{aligned} \text{FPer } H^r(U, f) &\simeq (H_{\text{dR}}^r(U, f), H_r^{\text{rd}}(U, f), P_r^{\text{rd,mod}}), \\ \text{FPer } H_c^r(U, f) &\simeq (H_{\text{dR},c}^r(U, f), H_r^{\text{mod}}(U, f), P_r^{\text{mod,rd}}), \\ \text{FPer } H_{\text{mid}}^r(U, f) &\simeq (H_{\text{dR,mid}}^r(U, f), H_r^{\text{mod}}(U, f), P_r^{\text{mid}}). \end{aligned}$$

A4. Period structures over the category of varieties and morphisms defined over \mathbb{Q} . In this section, we denote by U_0 a variety defined over \mathbb{Q} and by U the variety defined over \mathbb{C} after extension of scalars from \mathbb{Q} to \mathbb{C} . When working over varieties and morphism defined over \mathbb{Q} , that is, smooth separated schemes of finite type over \mathbb{Q} and separated morphisms (e.g., U_0 is \mathbb{A}^n or \mathbb{G}_m^n and f is a polynomial or a Laurent polynomial with rational coefficients), we are led to consider period structures over $\text{Spec } \mathbb{Q}$. Such a period structure consists of a pair of finite-dimensional \mathbb{Q} -vector spaces $(V_0, V_{\mathbb{Q}})$ together with a comparison isomorphism $\text{comp} : \mathbb{C} \otimes_{\mathbb{Q}} V_{\mathbb{Q}} \simeq \mathbb{C} \otimes_{\mathbb{Q}} V_0 = V^{\mathbb{C}}$.

\mathbb{Q} -structure on the de Rham cohomology. We fix a good compactification

$$j : (U_0, f) \hookrightarrow (\bar{X}_0, \bar{f}),$$

that is, such that $D_0 = X_0 \setminus U_0$ is a divisor with strict normal crossings (i.e., such that the irreducible components over $\bar{\mathbb{Q}}$ are smooth and intersect transversally). We work with the corresponding category of \mathcal{D} -modules and functors; see, e.g., [Laumon 1983, Sections 4 and 5]. The de Rham cohomology $H_{\text{dR}}^r(U_0, f)$ is defined in a standard way as the de Rham cohomology of the \mathcal{D}_{U_0} -module $(\mathcal{O}_{U_0}, d + df)$, and the de Rham cohomology with compact support $H_{\text{dR},c}^r(U_0, f)$ is the de Rham cohomology of the $\mathcal{D}_{\bar{X}_0}$ -module $j_{\dagger}(\mathcal{O}_{U_0}, d + df)$, with $j_{\dagger} = \mathbf{D} \circ j_+ \circ \mathbf{D}$ and \mathbf{D} is the duality functor of \mathcal{D} -modules. We denote by (U, f) the corresponding object obtained by extension of scalars from \mathbb{Q} to \mathbb{C} . We have:

Lemma A.26. *Extension of scalars is compatible with taking de Rham cohomology, that is,*

$$\mathbb{C} \otimes_{\mathbb{Q}} H_{\text{dR}}^r(U_0, f) \simeq H_{\text{dR}}^r(U, f), \quad \mathbb{C} \otimes_{\mathbb{Q}} H_{\text{dR},c}^r(U_0, f) \simeq H_{\text{dR},c}^r(U, f). \quad \square$$

As an immediate consequence we obtain that the same result holds for the middle de Rham cohomology $H_{\text{dR,mid}}^r(U_0, f)$.

Let us consider the setting of Remark A.17 and let us assume that the triple (U, f, Z) is defined over \mathbb{Q} . Let us set $M = (\mathcal{O}_{U_0}, d + df)$. There is a natural exact sequence

$$0 = R^0\Gamma_{Z_0}M \rightarrow M \rightarrow j_{Z_0+}j_{Z_0}^+M = M(*Z_0) \rightarrow R^1\Gamma_{Z_0}M \rightarrow 0$$

which identifies the complex $R\Gamma_{Z_0}M$ with $(\mathcal{O}_{U_0}(*Z_0)/\mathcal{O}_{U_0}, d + df)[-1]$. We note that

$$(\mathcal{O}_{U_0}(*Z_0)/\mathcal{O}_{U_0}, d + df) \simeq (\mathcal{O}_{U_0}(*Z_0)/\mathcal{O}_{U_0}, d).$$

Indeed, this amounts to showing that the exponential function $\exp(\pm f)$ is well-defined on $\mathcal{O}_{U_0}(*Z_0)/\mathcal{O}_{U_0}$, and this follows from the nilpotency of multiplication by f on each local section of $\mathcal{O}_{U_0}(*Z_0)/\mathcal{O}_{U_0}$. The long exact sequence in de Rham cohomology thus reads

$$\dots \rightarrow H_{\text{dR},Z_0}^r(U_0) \rightarrow H_{\text{dR}}^r(U_0, f) \rightarrow H_{\text{dR}}^r(U_0 \setminus Z_0, f) \rightarrow H_{\text{dR},Z_0}^{r+1}(U_0) \rightarrow \dots$$

Dually (in the sense of $\mathcal{D}_{\bar{X}_0}$ -modules, and up to changing f to $-f$), we obtain the exact sequence

$$\dots \rightarrow H_{\text{dR,c}}^{r-1}(Z_0) \rightarrow H_{\text{dR,c}}^r(U_0 \setminus Z_0, f) \rightarrow H_{\text{dR,c}}^r(U_0, f) \rightarrow H_{\text{dR,c}}^r(Z_0) \rightarrow \dots$$

Corollary A.27. *Assume moreover that the \mathbb{Q} -vector spaces $H_{\text{dR}}^r(U_0 \setminus Z_0, f)$ and $H_{\text{dR,c}}^r(U_0 \setminus Z_0, f)$ are zero for all r . Then the \mathbb{Q} -de Rham vector spaces $H_{\text{dR}}^r(U_0, f)$ and $H_{\text{dR},Z_0}^r(U_0)$, respectively $H_{\text{dR,c}}^r(U_0, f)$ and $H_{\text{dR,c}}^r(Z_0)$, coincide. \square*

Example A.28. We consider the setting of [Fresán et al. 2022, Example A.27] where the assumptions of Corollary A.27 hold. We thus assume that $U_0 = \mathbb{A}_t^1 \times V_0$ for some smooth quasiprojective variety V_0 and $f = tg$ for some regular function g on V_0 . We set $\mathcal{X}_0 = g^{-1}(0)$ and $Z_0 = \mathbb{A}_t^1 \times \mathcal{X}_0$. Corollary A.27 gives identifications of \mathbb{Q} -vector spaces

$$H_{\text{dR},Z_0}^r(U_0) \simeq H_{\text{dR}}^r(U_0, f) \quad \text{and} \quad H_{\text{dR,c}}^r(Z_0) \simeq H_{\text{dR,c}}^r(U_0, f).$$

Action of complex conjugation. We denote by $(U^{\mathbb{R}}, f^{\mathbb{R}})$ (or simply $U^{\mathbb{R}}, f^{\mathbb{R}}$) the real-analytic space and map associated with $(U(\mathbb{C}), f)$. Then the complex conjugation endows $U^{\mathbb{R}}$ with a real analytic involution conj which commutes with $f^{\mathbb{R}}$. Furthermore, one can find a compactification (\bar{X}_0, D_0) defined over \mathbb{Q} (since resolution of singularities holds in characteristic zero) so that conj extends in a unique way as a real analytic involution of $(\bar{X}^{\mathbb{R}}, D^{\mathbb{R}})$. Similarly, $\tilde{X}(D)^{\mathbb{R}}$, etc. belong to the semianalytic category and conj can then be lifted in a unique way as a semianalytic involution $\widetilde{\text{conj}}$ of $\tilde{X}(D)^{\mathbb{R}}$ that preserves $\partial\tilde{X}(D)^{\mathbb{R}}$. Lastly, since the moderate growth or rapid decay condition only involves $\text{Re}(f^{\mathbb{R}})$, the involution $\widetilde{\text{conj}}$ preserves the subsets $\tilde{U}_{\text{mod}}(D)^{\mathbb{R}}$ and $\tilde{U}_{\text{rd}}(D)^{\mathbb{R}}$.

Corollary A.29. *If (U, f) is obtained from (U_0, f) by extension of scalars, the \mathbb{Q} -Betti fibers $H_{\text{B}}^r(U, f)$ and $H_{\text{B,c}}^r(U, f)$ are naturally endowed with an involution conj^* , which is compatible with the natural morphism $H_{\text{B,c}}^r(U, f) \rightarrow H_{\text{B}}^r(U, f)$.*

Proof. Indeed, conj^* is induced by

$$\widetilde{\text{conj}}^* : H_c^r(\widetilde{U}_{\text{mod}}(D)^{\mathbb{R}}, \mathbb{Q}) \rightarrow H_c^r(\widetilde{U}_{\text{mod}}(D)^{\mathbb{R}}, \mathbb{Q}) \quad \text{or} \quad \widetilde{\text{conj}}^* : H_c^r(\widetilde{U}_{\text{rd}}(D)^{\mathbb{R}}, \mathbb{Q}) \rightarrow H_c^r(\widetilde{U}_{\text{rd}}(D)^{\mathbb{R}}, \mathbb{Q}). \quad \square$$

Corollary A.30. *In the setting of Remark A.17, assume that (U_0, f, Z_0) is defined over \mathbb{Q} . Then $\widetilde{\text{conj}}^*$ is compatible with the morphisms of the Betti exact sequence (A.18). In particular, if $H_c^r(U \setminus Z, f) = 0$ for all r , then the involutions conj^* on $H_{B,c}^r(U, f)$ and $H_c^r(Z^{\mathbb{R}}, \mathbb{Q})$ coincide. \square*

Example A.31. Let us keep the setting of Example A.28, that is, [Fresán et al. 2022, Example A.27]. It is proved in [loc. cit.] that, for all $r \in \mathbb{Z}$, we have a diagram of mixed Hodge structures

$$\begin{array}{ccc} H_c^r(\mathbb{A}_t^1 \times V, f) & \xrightarrow{\sim} & H_c^{r-2}(Z)(-1) \\ \downarrow & & \\ H^r(\mathbb{A}_t^1 \times V, f) & \xleftarrow{\sim} & H_Z^r(\mathbb{A}_t^1 \times V) \end{array} \tag{A.32}$$

where the vertical arrow is the natural one. Consider the case $r = d$, the dimension of $\mathbb{A}_t^1 \times V$. According to [loc. cit., Proposition A.19], the upper line is mixed of weights $\leq d$ and the lower line is mixed of weights $\geq d$. Furthermore, denoting by $H_{\text{mid}}^d(\mathbb{A}_t^1 \times V, f)$ the image of the vertical arrow, we have induced isomorphisms of pure Hodge structure:

$$\begin{array}{ccc} \text{gr}_d^W H_c^d(\mathbb{A}_t^1 \times V, f) & \xrightarrow{\sim} & (\text{gr}_{d-2}^W H_c^{d-2}(Z))(-1) \\ \downarrow \wr & & \\ H_{\text{mid}}^d(\mathbb{A}_t^1 \times V, f) & \xrightarrow{\sim} & W_d H^d(\mathbb{A}_t^1 \times V, f) \xleftarrow{\sim} W_d H_Z^d(\mathbb{A}_t^1 \times V) \end{array}$$

We assume that V_0, g are defined over \mathbb{Q} , making U_0, f also defined over \mathbb{Q} , as well as $\mathcal{X}_0 = g^{-1}(0)$ and $Z_0 = \mathbb{A}_t^1 \times \mathcal{X}$, so that $\mathcal{X}^{\mathbb{R}}$ and $Z^{\mathbb{R}}$ are preserved by conj . It follows from Corollary A.30 that the isomorphisms of (exponential) mixed Hodge structures (A.32) induce isomorphisms of Betti fibers which are compatible with conj^* .

Furthermore, the weight filtration $W_\bullet H_c^r(Z^{\mathbb{R}}, \mathbb{Q})$ is preserved by conj^* , since it comes from a filtration defined at the level of Nori motives; see [Huber and Müller-Stach 2017, Theorem 10.2.5]. One can argue that the weight filtration of $H_{B,c}^r(\mathbb{A}_t^1 \times V, f)$ is also preserved by conj^* by analyzing first the behavior of conj^* on $R^r f_* \mathbb{Q}_U$. Nevertheless, it is enough for our purpose to check that conj^* induces an action on $H_{B,\text{mid}}^r(\mathbb{A}_t^1 \times V, f)$, a property that follows from interpreting the latter space as the image of the Betti vertical arrow (A.32).

Acknowledgments

It is our pleasure to thank David Broadhurst and David Roberts for useful correspondence on the subject of their conjecture.

Added in proof

Recently, Y. Zhou also obtained [2021] the existence of quadratic relations as conjectured by Broadhurst and Roberts, with a different interpretation of the matrix D_k however. The methods are completely different from those of the present article and rely on the previous works of the author.

References

- [Bloch et al. 2015] S. Bloch, M. Kerr, and P. Vanhove, “A Feynman integral via higher normal functions”, *Compos. Math.* **151**:12 (2015), 2329–2375. [MR](#) [Zbl](#)
- [Broadhurst 2016] D. Broadhurst, “Feynman integrals, L-series and Kloosterman moments”, *Commun. Number Theory Phys.* **10**:3 (2016), 527–569. [MR](#) [Zbl](#)
- [Broadhurst 2017a] D. Broadhurst, “Critical L-values for products of up to 20 Bessel functions”, lecture notes, 2017, available at https://www.matrix-inst.org.au/wp_Matrix2016/wp-content/uploads/2016/04/Broadhurst-2.pdf.
- [Broadhurst 2017b] D. Broadhurst, “L-series from Feynman diagrams with up to 22 loops”, lecture notes, 2017, available at <https://multi-loop-2017.sciencesconf.org/data/program/Broadhurst.pdf>.
- [Broadhurst and Mellit 2016] D. Broadhurst and A. Mellit, “Perturbative quantum field theory informs algebraic geometry”, pp. 079 in *Proceedings of loops and legs in quantum Field Theory* (PoS, 2016), vol. 260, 2016.
- [Broadhurst and Roberts 2018] D. Broadhurst and D. Roberts, “Quadratic relations between Feynman integrals”, pp. 053 in *Proceedings of loops and legs in quantum field theory* (PoS, 2018), vol. 303, 2018.
- [Broadhurst and Roberts 2019] D. Broadhurst and D. Roberts, “L-series and Feynman integrals”, pp. 401–403 in 2017 *MATRIX annals*, edited by D. R. Wood et al., MATRIX Book Ser. **2**, Springer, 2019. [MR](#) [Zbl](#)
- [Deligne 1979] P. Deligne, “Valeurs de fonctions L et périodes d’intégrales”, pp. 313–346 in *Automorphic forms, representations and L-functions, part 2* (Oregon State Univ., Corvallis, Ore., 1977), edited by A. Borel and W. Casselman, Proc. Sympos. Pure Math. **XXXIII**, Amer. Math. Soc., Providence, R.I., 1979. [MR](#) [Zbl](#)
- [Fresán et al. 2022] J. Fresán, C. Sabbah, and J.-D. Yu, “Hodge theory of Kloosterman connections”, *Duke Math. J.* **171**:8 (2022), 1649–1747. [MR](#) [Zbl](#)
- [Fresán et al. 2023] J. Fresán, C. Sabbah, and J.-D. Yu, “Quadratic relations between periods of connections”, *Tohoku Math. J.* **75**:2 (2023). To appear. [arXiv 2005.11525](https://arxiv.org/abs/2005.11525)
- [Hien 2007] M. Hien, “Periods for irregular singular connections on surfaces”, *Math. Ann.* **337**:3 (2007), 631–669. [MR](#) [Zbl](#)
- [Hien 2009] M. Hien, “Periods for flat algebraic connections”, *Invent. Math.* **178**:1 (2009), 1–22. [MR](#) [Zbl](#)
- [Huber and Müller-Stach 2017] A. Huber and S. Müller-Stach, *Periods and Nori motives*, *Ergeb. Math. Grenzgeb.* **65**, Springer, 2017. [MR](#) [Zbl](#)
- [Kashiwara and Schapira 1990] M. Kashiwara and P. Schapira, *Sheaves on manifolds*, *Grundlehr. Math. Wissen.* **292**, Springer, 1990. [MR](#) [Zbl](#)
- [Koelink and Van Assche 1995] H. T. Koelink and W. Van Assche, “Orthogonal polynomials and Laurent polynomials related to the Hahn–Exton q-Bessel function”, *Constr. Approx.* **11**:4 (1995), 477–512. [MR](#) [Zbl](#)
- [Kontsevich and Soibelman 2011] M. Kontsevich and Y. Soibelman, “Cohomological Hall algebra, exponential Hodge structures and motivic Donaldson–Thomas invariants”, *Commun. Number Theory Phys.* **5**:2 (2011), 231–352. [MR](#) [Zbl](#)
- [Krattenthaler 2005] C. Krattenthaler, “Advanced determinant calculus: a complement”, *Linear Algebra Appl.* **411** (2005), 68–166. [MR](#) [Zbl](#)
- [Laumon 1983] G. Laumon, “Sur la catégorie dérivée des D-modules filtrés”, pp. 151–237 in *Algebraic geometry* (Tokyo/Kyoto, 1982), edited by M. Raynaud and T. Shioda, Lecture Notes in Math. **1016**, Springer, 1983. [MR](#) [Zbl](#)
- [Malgrange 1991] B. Malgrange, *Équations différentielles à coefficients polynomiaux*, *Progress in Mathematics* **96**, Birkhäuser, Boston, MA, 1991. [MR](#) [Zbl](#)
- [Mochizuki 2014] T. Mochizuki, “Holonomic \mathcal{D} -modules with Betti structure”, *Mém. Soc. Math. Fr. (N.S.)* 138–139 (2014), viii+205. [MR](#) [Zbl](#)

- [Roberts 2017] D. Roberts, “Some Feynman integrals and their motivic interpretation”, lecture notes, 2017, available at <https://www.davidproberts.net/presentations>.
- [Sabbah 1996] C. Sabbah, “On the comparison theorem for elementary irregular \mathcal{D} -modules”, *Nagoya Math. J.* **141** (1996), 107–124. [MR](#) [Zbl](#)
- [Saito 1990] M. Saito, “Mixed Hodge modules”, *Publ. Res. Inst. Math. Sci.* **26**:2 (1990), 221–333. [MR](#) [Zbl](#)
- [Saito 2017] M. Saito, “A young person’s guide to mixed Hodge modules”, pp. 517–553 in *Hodge theory and L^2 -analysis*, edited by L. Ji, Adv. Lect. Math. (ALM) **39**, International Press, Somerville, MA, 2017. [MR](#) [Zbl](#)
- [Vanhove 2014] P. Vanhove, “The physics and the mixed Hodge structure of Feynman integrals”, pp. 161–194 in *String-Math 2013*, edited by R. Donagi et al., Proc. Sympos. Pure Math. **88**, Amer. Math. Soc., Providence, RI, 2014. [MR](#) [Zbl](#)
- [Watson 1944] G. N. Watson, *A treatise on the theory of Bessel functions*, Cambridge University Press, 1944. [MR](#) [Zbl](#)
- [Zhang and Chen 2014] R. Zhang and L.-C. Chen, “On certain matrices of Bernoulli numbers”, *Abstr. Appl. Anal.* (2014), Art. ID 536325, 4. [MR](#) [Zbl](#)
- [Zhou 2018a] Y. Zhou, “Wick rotations, Eichler integrals, and multi-loop Feynman diagrams”, *Commun. Number Theory Phys.* **12**:1 (2018), 127–192. [MR](#) [Zbl](#)
- [Zhou 2018b] Y. Zhou, “Wronskian factorizations and Broadhurst–Mellit determinant formulae”, *Commun. Number Theory Phys.* **12**:2 (2018), 355–407. [MR](#) [Zbl](#)
- [Zhou 2019a] Y. Zhou, “Hilbert transforms and sum rules of Bessel moments”, *Ramanujan J.* **48**:1 (2019), 159–172. [MR](#) [Zbl](#)
- [Zhou 2019b] Y. Zhou, “ \mathbf{Q} -linear dependence of certain Bessel moments”, preprint, 2019. To appear in *Ramanujan J.* [arXiv 1911.04141](#)
- [Zhou 2021] Y. Zhou, “Wronskian algebra and Broadhurst–Roberts quadratic relations”, *Commun. Number Theory Phys.* **15**:4 (2021), 651–741. [MR](#) [Zbl](#)

Communicated by Bjorn Poonen

Received 2020-06-11 Revised 2021-06-21 Accepted 2022-05-10

javier.fresan@polytechnique.edu

Centre de Mathématiques Laurent Schwartz, CNRS, École polytechnique, Institut Polytechnique de Paris, France

claude.sabbah@polytechnique.edu

Centre de Mathématiques Laurent Schwartz, CNRS, École polytechnique, Institut Polytechnique de Paris, France

jdyu@ntu.edu.tw

Department of Mathematics, National Taiwan University, Taipei, Taiwan

Morphismes de périodes et cohomologie syntomique

Sally Gilles

On commence par donner la version géométrique d'un résultat de Colmez et Nizioł établissant un théorème de comparaison entre les cycles proches p -adiques arithmétiques et la cohomologie des faisceaux syntomiques. La construction locale de cet isomorphisme utilise la théorie des (φ, Γ) -modules et s'obtient en réduisant l'isomorphisme de périodes à un théorème de comparaison entre des cohomologies d'algèbres de Lie. En appliquant ensuite la méthode des « coordonnées plus générales » utilisée par Bhatt, Morrow et Scholze, on construit un isomorphisme global. On peut notamment déduire de ce théorème la conjecture semi-stable de Fontaine et Jannsen. Ce résultat a également été prouvé par (entre autres) Tsuji, via l'application de Fontaine et Messing, et par Česnavičius et Koshikawa, qui généralisent la preuve de la conjecture cristalline de Bhatt, Morrow et Scholze. On utilise l'application construite précédemment pour montrer que le morphisme de périodes de Tsuji est égal à celui de Česnavičius et Koshikawa.

We start by giving the geometric version of a result of Colmez and Nizioł establishing a comparison theorem between p -adic arithmetic nearby cycles and syntomic sheaf cohomology. The local construction of this isomorphism uses (φ, Γ) -modules and is obtained by reducing the period isomorphism to a comparison theorem between cohomologies of Lie algebras. Then, applying Bhatt, Morrow and Scholze's "more general coordinates" method, we construct a global isomorphism. We can deduce from this theorem the semistable conjecture of Fontaine and Jannsen. This result was also proved, among others, by Tsuji, using Fontaine and Messing's map, and by Česnavičius and Koshikawa, who generalize the proof of Bhatt, Morrow and Scholze's crystalline conjecture. We use the previously constructed mapping to show that Tsuji's period morphism is equal to the one of Česnavičius and Koshikawa.

1. Introduction	604
2. Cohomologie syntomique et résultat local	612
3. Anneaux de périodes	617
4. Passage de R_{cris}^+ à $R^{[u,v]}$	622
5. Utilisation des (φ, Γ) -modules	628
6. Cohomologie de Galois	636
7. Comparaison locale avec l'application de Fontaine–Messing	638
8. Résultat global	642
9. Comparaison des morphismes de périodes	651
Remerciements	664
Bibliographie	664

MSC2020: primary 11S25, 14F20, 14F30, 14F40; secondary 14G22.

Mots-clefs: syntomic cohomology, period morphism, p -adic cohomology, p -adic Hodge theory.

1. Introduction

Les morphismes de périodes permettent de décrire la cohomologie étale p -adique de variétés algébriques à l'aide de formes différentielles et rendent ainsi possible son calcul. Plusieurs constructions de tels morphismes existent. Tsuji [1999], par exemple, établit que l'application de Fontaine et Messing [1987] (aussi décrite dans [Kato 1994]) définit un quasi-isomorphisme, en degrés bornés, entre les cycles proches p -adiques et la cohomologie étale p -adique de la variété rigide associée à un schéma à réduction semi-stable. Tsuji déduit de ce résultat une preuve de la conjecture semi-stable de Fontaine et Jannsen qui relie la cohomologie p -adique de la variété à sa cohomologie de Hyodo–Kato (telle qu'elle est définie dans [Beilinson 2013]). Une autre preuve de la conjecture semi-stable, généralisant la preuve de la conjecture cristalline de Bhatt, Morrow et Scholze (voir [Bhatt et al. 2018]), a été donnée par Česnavičius et Koshikawa [2019]. Ce travail comporte deux parties : dans un premier temps, on donne une preuve différente du résultat de Tsuji en construisant un nouveau morphisme de périodes (qui est la version géométrique de celui de Colmez et Niziol [2017]). On utilise ensuite cette construction pour montrer que l'application de Fontaine et Messing et le morphisme de Bhatt, Morrow et Scholze sont égaux.

1A. Énoncé des principaux théorèmes. Décrivons plus précisément les résultats obtenus. On fixe p un nombre premier. Soit \mathcal{O}_K un anneau de valuation discrète complet, de corps de fraction K de caractéristique 0 et de corps résiduel parfait k de caractéristique p . On note ϖ une uniformisante de K , $\mathcal{O}_F := W(k)$ l'anneau des vecteurs de Witt associé à k et $F = \text{Frac}(\mathcal{O}_F)$ (avec $e := [K : F]$). Soit \bar{K} la clôture algébrique de K et $\mathcal{O}_{\bar{K}}$ la clôture intégrale de \mathcal{O}_K dans \bar{K} . Enfin, on note C le corps complet algébriquement clos $\widehat{\bar{K}}$ et \mathcal{O}_C son anneau de valuation.

On note \mathcal{O}_K^\times le schéma formel $\text{Spf}(\mathcal{O}_K)$ muni de la log-structure donnée par son point fermé et \mathcal{O}_F^0 le schéma formel $\text{Spf}(W(k))$ muni de la log-structure $(\mathbb{N} \rightarrow \mathcal{O}_F, 1 \mapsto 0)$. On considère \mathfrak{X} un log-schéma formel à réduction semi-stable, log-lisse sur \mathcal{O}_K^\times . On note $Y := \mathfrak{X}_k$ sa fibre spéciale, $\bar{\mathfrak{X}} := \mathfrak{X}_{\mathcal{O}_C}$ et $\bar{Y} := \bar{\mathfrak{X}}_{\bar{k}}$. Soit $\mathcal{S}_n(r)_{\mathfrak{X}}$ dans $D(Y_{\text{ét}}, \mathbb{Z}/p^n\mathbb{Z})^1$ et $\mathcal{S}_n(r)_{\bar{\mathfrak{X}}}$ dans $D((\bar{Y})_{\text{ét}}, \mathbb{Z}/p^n\mathbb{Z})$ les faisceaux syntomiques arithmétique et géométrique. On note $\mathfrak{X}_{K,\text{tr}}$ (respectivement $\mathfrak{X}_{C,\text{tr}}$) le lieu de \mathfrak{X}_K (respectivement de \mathfrak{X}_C) où la structure logarithmique est triviale, et i et j (respectivement \bar{i} et \bar{j}) les morphismes $^2 Y \hookrightarrow \mathfrak{X}$ et $\mathfrak{X}_{K,\text{tr}} \dashrightarrow \mathfrak{X}$ (respectivement $\bar{Y} \hookrightarrow \bar{\mathfrak{X}}$ et $\mathfrak{X}_{C,\text{tr}} \dashrightarrow \bar{\mathfrak{X}}$). Enfin, soit $\mathbb{Z}_p(r)' := \frac{1}{a(r)!p^{a(r)}}\mathbb{Z}_p(r)$, $r = a(r)(p-1) + b(r)$ avec $0 \leq b(r) \leq p-2$.

Théorème 1.1. *Pour tout $0 \leq k \leq r$, il existe un p^N -isomorphisme 3*

$$\alpha_{r,n}^0 : \mathcal{H}^k(\mathcal{S}_n(r)_{\bar{\mathfrak{X}}}) \rightarrow \bar{i}^* R^k \bar{j}_* \mathbb{Z}/p^n(r)'_{\mathfrak{X}_{C,\text{tr}}}$$

où N est un entier qui dépend de p et de r , mais pas de \mathfrak{X} ni de n .

Notons $\alpha_{r,n}^{\text{FM}} : \mathcal{S}_n(r)_{\mathfrak{X}} \rightarrow i^* Rj_* \mathbb{Z}/p^n(r)'_{\mathfrak{X}_{K,\text{tr}}}$ (respectivement $\mathcal{S}_n(r)_{\bar{\mathfrak{X}}} \rightarrow \bar{i}^* R\bar{j}_* \mathbb{Z}/p^n(r)'_{\mathfrak{X}_{C,\text{tr}}}$) l'application de Fontaine–Messing arithmétique (respectivement géométrique). Tsuji [1999, Theorem 0.4] montre

1. Où $D(Y_{\text{ét}}, A)$ est la catégorie dérivée des faisceaux de A -modules sur le site étale de Y , pour un anneau A .
 2. Les morphismes j et \bar{j} n'existent pas au niveau des espaces, mais on dispose bien de morphismes de topoi Rj_* et $R\bar{j}_*$.
 3. On appelle p^N -isomorphisme, un morphisme dont le noyau et le conoyau sont tués par p^N .

le [théorème 1.1](#) dans le cas où \mathfrak{X} est un schéma à réduction semi-stable sur $\text{Spec}(\mathcal{O}_K)$ en prouvant que l’application de Fontaine–Messing fournit le p^N -isomorphisme voulu. Pour cela, il commence par se ramener au cas $n = 1$ par dévissage. En multipliant le faisceau syntomique (respectivement le faisceau de cycle proche) par t avec $t = \log([\varepsilon])$, où $\varepsilon \in \mathcal{O}_C^b$ est un système de racine p -ième de l’unité (respectivement par ζ_p), il se ramène au cas $k = r$. Il utilise ensuite une description des faisceaux $\mathcal{H}^r(\mathcal{S}_n(r)_{\bar{\mathfrak{X}}})$ via des applications symboles qu’il compare avec celle de $i^* R^k j_* \mathbb{Z}/p^n(r)'_{\mathfrak{X}_{C, \text{tr}}}$ donnée par Bloch et Kato [1986] dans le cas de la bonne réduction, puis étendue à la réduction semi-stable par Hyodo [1988].

Colmez et Nizioł [2017] prouvent la version arithmétique du théorème ci-dessus, c’est-à-dire :

Théorème 1.2 [Colmez et Nizioł 2017, Theorem 1.1]. *Pour tout $0 \leq k \leq r$, l’application*

$$\alpha_{r,n}^{\text{FM}} : \mathcal{H}^k(\mathcal{S}_n(r)_{\mathfrak{X}}) \rightarrow i^* R^k j_* \mathbb{Z}/p^n(r)'_{\mathfrak{X}_{K, \text{tr}}}$$

est un p^N -isomorphisme pour une constante N qui dépend de e , p et de r , mais pas de \mathfrak{X} ni de n .

Pour cela, ils construisent un p^N -quasi-isomorphisme local qu’ils comparent ensuite à la définition locale de l’application de Fontaine–Messing. Le [théorème 1.1](#) peut ensuite se déduire du [théorème 1.2](#) en passant à la limite sur les extensions finies L de K . Une nouvelle preuve du résultat de Colmez et Nizioł a récemment été donnée dans [Antieau et al. 2022] dans le cas où \mathfrak{X} est propre et lisse sur \mathcal{O}_K .

On prouve ici le [théorème 1.1](#) directement. On commence par montrer un résultat local semblable à celui de Colmez et Nizioł. On considère R la complétion p -adique d’une algèbre étale sur

$$R_{\square} := \mathcal{O}_C \left\{ X_1, \dots, X_d, \frac{1}{X_1 \cdots X_a}, \frac{\varpi}{X_{a+1} \cdots X_{a+b}} \right\}$$

(pour a, b, c et d des entiers tels que $a + b + c = d$). On note $D = \{X_{a+b+1} \cdots X_d = 0\}$ le diviseur à l’infini et $\bar{R}[1/p]$ l’extension maximale de $R[1/p]$ non ramifiée en dehors de D . Soit $G_R = \text{Gal}(\bar{R}[1/p]/R[1/p])$.⁴ On relève ensuite R en une algèbre R_{inf}^+ sur

$$R_{\text{inf}, \square}^+ := \mathbb{A}_{\text{inf}} \left\{ X, \frac{1}{X_1 \cdots X_a}, \frac{[\varpi^b]}{X_{a+1} \cdots X_{a+b}} \right\}$$

(où $\varpi^b \in \mathcal{O}_C^b$ est un système de racines p -ièmes de ϖ), on définit⁵ $R_{\text{cris}}^+ := R_{\text{inf}}^+ \hat{\otimes}_{\mathbb{A}_{\text{inf}}} \mathbb{A}_{\text{cris}}$. Ici $\text{Spf}(R)$ est muni de la log-structure donnée par la fibre spéciale et le diviseur à l’infini et $\text{Spf}(\mathbb{A}_{\text{cris}})$ ainsi que $\text{Spf}(\mathbb{A}_{\text{inf}})$ sont munis des log-structures usuelles décrites dans [Česnavičius et Koshikawa 2019, § 1.6] (voir la [section 2B2](#) ci-dessous). On s’intéresse au complexe syntomique donné par la fibre homotopique

$$\text{Syn}(R_{\text{cris}}^+, r) := [F^r \Omega_{R_{\text{cris}}^+}^{\bullet} \xrightarrow{p^r - \varphi} \Omega_{R_{\text{cris}}^+}^{\bullet}]$$

où φ est le Frobenius sur R_{cris}^+ qui étend celui de $R_{\text{inf}, \square}^+$ donné par le Frobenius usuel sur \mathbb{A}_{inf} et par $\varphi(X_i) = X_i^p$. Le complexe $\text{Syn}(R_{\text{cris}}^+, r)$ calcule alors la cohomologie syntomique de $\text{Spf}(R)$. On note $\text{Syn}(R_{\text{cris}}^+, r)_n$ sa réduction modulo p^n . On a le résultat local suivant :

4. On utilise ici la notation Gal pour désigner le groupe des automorphismes de $\bar{R}[1/p]$ qui fixent $R[1/p]$.

5. Ici le produit tensoriel est complété pour la topologie p -adique.

Théorème 1.3. *Il existe des p^N -quasi-isomorphismes*

$$\begin{aligned} \alpha_r^0 : \tau_{\leq r} \operatorname{Syn}(R_{\text{cris}}^+, r) &\xrightarrow{\sim} \tau_{\leq r} R\Gamma(G_R, \mathbb{Z}_p(r)), \\ \alpha_{r,n}^0 : \tau_{\leq r} \operatorname{Syn}(R_{\text{cris}}^+, r)_n &\xrightarrow{\sim} \tau_{\leq r} R\Gamma(G_R, \mathbb{Z}/p^n(r)), \end{aligned}$$

où N est une constante qui ne dépend que de r .

Les applications ci-dessus sont notamment utilisées par Colmez et Nizioł [2021a] pour donner une interprétation « géométrique » des morphismes de périodes, i.e., voir les théorèmes de comparaison entre les cohomologies étale et syntomique comme des théorèmes de comparaison entre les C -points d’espaces de Banach–Colmez. Cela leur permet ensuite d’étendre le théorème de comparaison semi-stable à des variétés rigides analytiques plus générales dans [Colmez et Nizioł 2021b].

Si \mathfrak{X} est propre sur \mathcal{O}_K , on déduit du théorème 1.1 que α_r^0 induit un quasi-isomorphisme Frobenius et G_K -équivariant, qui préserve la filtration après tensorisation par \mathbb{B}_{dR} :

$$\begin{aligned} \tilde{\alpha}^0 : H_{\text{ét}}^i(\mathfrak{X}_C, \mathbb{Q}_p) \otimes_{\mathbb{Q}_p} \mathbb{B}_{\text{st}} &\cong H_{\text{HK}}^i(\mathfrak{X}) \otimes_F \mathbb{B}_{\text{st}}, \\ H_{\text{ét}}^i(\mathfrak{X}_C, \mathbb{Q}_p) \otimes_{\mathbb{Q}_p} \mathbb{B}_{\text{dR}} &\cong H_{\text{dR}}^i(\mathfrak{X}_K) \otimes_K \mathbb{B}_{\text{dR}}, \end{aligned}$$

où $R\Gamma_{\text{HK}}(\mathfrak{X}) \cong R\Gamma_{\text{cris}}(\mathfrak{X}_k/W(k)^0)_{\mathbb{Q}}$. Par les résultats de Tsuji et de Colmez–Nizioł, le morphisme α_r^{FM} induit, lui aussi, un isomorphisme $\tilde{\alpha}^{\text{FM}}$ entre les mêmes objets. Enfin, Česnavičius et Koshikawa [2019], donnent une troisième construction d’un tel isomorphisme $\tilde{\alpha}^{\text{CK}}$ (qui étend la construction de Bhatt et al. [2018]). Dans la seconde partie de cet article, on montre :

Théorème 1.4. *Les morphismes $\tilde{\alpha}^{\text{FM}}$ et $\tilde{\alpha}^0$ d’une part et $\tilde{\alpha}^{\text{CK}}$ et $\tilde{\alpha}^0$ d’autre part sont égaux. En particulier, $\tilde{\alpha}^{\text{FM}} = \tilde{\alpha}^{\text{CK}}$.*

Ce dernier théorème étend les résultats de Nizioł [2009; 2020], dans lesquels elle prouve l’égalité entre les morphismes de périodes de [Faltings 2002; Beilinson 2013; Nizioł 2008]. La preuve de Nizioł fait intervenir la h -topologie et sa méthode ne s’applique pas au morphisme $\tilde{\alpha}^{\text{CK}}$, puisque dans leur définition, Česnavičius et Koshikawa n’autorisent pas de diviseur horizontal. L’unicité est ici obtenue en comparant « à la main » les constructions locales des morphismes de périodes. Cela est possible car, localement, $\tilde{\alpha}^{\text{CK}}$ est construit en utilisant des complexes de Koszul similaires à ceux qui interviennent dans la construction de $\tilde{\alpha}^0$. La principale différence est que la définition de [Česnavičius et Koshikawa 2019] utilise le foncteur de décalage $L\eta_{\mu}$ (i.e., les termes des complexes sont multipliés par des puissances de $\mu = [\varepsilon] - 1$) alors que dans le cas de $\tilde{\alpha}^0$ les complexes sont multipliés par des puissances de $t = \log([\varepsilon])$.

La définition de Fontaine et Messing et celle de Bhatt et al. ont chacune leurs propres avantages. Le morphisme de périodes construit par Bhatt et al. et par Česnavičius et Koshikawa est, par exemple, plus adapté pour travailler au niveau intégral. Ce résultat d’unicité permet ainsi d’obtenir pour l’application de Bhatt et al. les propriétés déjà connues pour l’application de Fontaine et Messing (notamment, la compatibilité aux applications symboles).

1B. Preuve du théorème 1.3. Nous expliquons dans un premier temps comment construire le p^N -quasi-isomorphisme local. On part du complexe $\text{Syn}(R_{\text{cris}}^+, r)$. On commence par « changer la convergence » des éléments de R_{cris}^+ . Pour $0 < u < v$, on définit l’anneau $\mathbb{A}^{[u]}$ (respectivement $\mathbb{A}^{[u,v]}$) comme la complétion p -adique de $\mathbb{A}_{\text{inf}}[[\beta]/p]$ (respectivement de $\mathbb{A}_{\text{inf}}[p/[\alpha], [\beta]/p]$) pour β un élément de \mathcal{O}_C^b de valuation $1/u$ (respectivement α et β des éléments de \mathcal{O}_C^b de valuation $1/v$ et $1/u$). Pour des valeurs de u et de v convenables, on déduit de la suite exacte

$$0 \rightarrow \mathbb{Z}_p t^{\{r\}} \rightarrow F^r \mathbb{A}_{\text{cris}} \xrightarrow{1-\varphi/p^r} \mathbb{A}_{\text{cris}} \rightarrow 0 \tag{1}$$

où $t^{\{r\}} := \frac{t^r}{a(r)!p^{a(r)}}$, des suites p^{6r} -exactes

$$\begin{aligned} 0 \rightarrow \mathbb{Z}_p(r) \rightarrow F^r \mathbb{A}^{[u]} \xrightarrow{p^r-\varphi} \mathbb{A}^{[u]} \rightarrow 0, \\ 0 \rightarrow \mathbb{Z}_p(r) \rightarrow F^r \mathbb{A}^{[u,v]} \xrightarrow{p^r-\varphi} \mathbb{A}^{[u,v]} \rightarrow 0. \end{aligned} \tag{2}$$

On définit $R^{[u]} := R_{\text{inf}}^+ \widehat{\otimes}_{\mathbb{A}_{\text{inf}}} \mathbb{A}^{[u]}$ et $R^{[u,v]} := R_{\text{inf}}^+ \widehat{\otimes}_{\mathbb{A}_{\text{inf}}} \mathbb{A}^{[u,v]}$, et pour $S \in \{R^{[u]}, R^{[u,v]}\}$, on pose $C(S, r) := [F^r \Omega_S^{\bullet} \xrightarrow{p^r-\varphi} \Omega_S^{\bullet}]$. Les suites exactes (2) ci-dessus permettent alors de montrer les $p^{N_1 r}$ -quasi-isomorphismes ⁷

$$\text{Syn}(R_{\text{cris}}^+, r) \cong C(R^{[u]}, r) \cong C(R^{[u,v]}, r).$$

En plongeant $R^{[u]}$ et $R^{[u,v]}$ dans des anneaux de périodes $\mathbb{A}_{\bar{R}}^{[u]}$ et $\mathbb{A}_{\bar{R}}^{[u,v]}$ (construits de manière similaire à $\mathbb{A}^{[u]}$ et $\mathbb{A}^{[u,v]}$ en utilisant \bar{R} au lieu de \mathcal{O}_C), on les munit d’une action du groupe de Galois G_R . On note $\mathbb{A}_R^{[u]}$ et $\mathbb{A}_R^{[u,v]}$ leurs images respectives par ce plongement. On se place ensuite dans une base de Ω_R^1 pour écrire le complexe $C(R^{[u,v]}, r)$ sous la forme d’un complexe de Koszul $\text{Kos}(\varphi, \partial, F^r \mathbb{A}_R^{[u,v]})$. La multiplication par $t = \log([\varepsilon]) \in \mathbb{A}_{\text{cris}}$ (où $\varepsilon \in \mathcal{O}_C^b$ est un système de racines p -ièmes de l’unité) permet de se débarrasser de la filtration en transformant l’action des différentielles en une action de l’algèbre de Lie du groupe $\Gamma_R = \text{Gal}(R_{\infty}[1/p]/R[1/p]) \cong \mathbb{Z}_p^d$ avec $R_{\infty} := (\varinjlim_m R_m)^{\wedge p}$ et

$$R_m := \left(\mathcal{O}_C \left\{ X^{1/p^m}, \frac{1}{(X_1 \cdots X_a)^{1/p^m}}, \frac{\varpi^{1/p^m}}{(X_{a+1} \cdots X_{a+b})^{1/p^m}} \right\} \right) \widehat{\otimes}_{\mathcal{O}_C} R.$$

C’est à cette étape qu’il est nécessaire de tronquer les complexes en degré r pour garder des isomorphismes. Finalement, on a la suite de $p^{N_2 r}$ -quasi-isomorphismes ⁸

$$\tau_{\leq r} \text{Kos}(\varphi, \partial, F^r \mathbb{A}_R^{[u,v]}) \xrightarrow{\sim} \tau_{\leq r} \text{Kos}(\varphi, \text{Lie } \Gamma_R, \mathbb{A}_R^{[u,v]}(r)) \xleftarrow{\sim} \tau_{\leq r} \text{Kos}(\varphi, \Gamma_R, \mathbb{A}_R^{[u,v]}(r)). \tag{3}$$

Soit R_{inf} la complétion p -adique de $R_{\text{inf}}^+[1/[\varpi^b]]$ et \mathbb{A}_R son image dans $\mathbb{A}_{\text{inf}}(\bar{R}^b)$. On montre ensuite qu’on a un quasi-isomorphisme $\text{Kos}(\varphi, \Gamma_R, \mathbb{A}_R^{[u,v]}) \cong \text{Kos}(\varphi, \Gamma_R, \mathbb{A}_R)$. Pour cela, on passe par l’intermédiaire d’un anneau $\mathbb{A}_R^{(0,v)+}$, construit à partir de l’anneau

$$\mathbb{A}^{(0,v)+} := \left\{ x = \sum_{n \in \mathbb{N}} [x_n] p^n \in \mathbb{A}_{\text{inf}} \mid x_n \in \mathcal{O}_C^b, v_{\mathcal{O}_C^b}(x_n) + \frac{n}{v} \geq 0 \text{ et } v_{\mathcal{O}_C^b}(x_n) + \frac{n}{v} \rightarrow +\infty \text{ quand } n \rightarrow \infty \right\},$$

6. Les produits tensoriels sont complétés pour la topologie p -adique.

7. Pour un $N_1 \in \mathbb{N}$.

8. Pour un $N_2 \in \mathbb{N}$.

et on utilise ψ , un inverse à gauche du Frobenius φ . Enfin, des arguments de descente presque étale et de décomplétion permettent d’obtenir un quasi-isomorphisme

$$\text{Kos}(\varphi, \Gamma_R, \mathbb{A}_R) \xrightarrow{\sim} \text{Kos}(\varphi, \Gamma_R, \mathbb{A}_{R_\infty}) \xrightarrow{\sim} \text{Kos}(\varphi, G_R, \mathbb{A}_{\bar{R}})$$

et la suite exacte $0 \rightarrow \mathbb{Z}_p \rightarrow \mathbb{A}_{\bar{R}} \xrightarrow{1-\varphi} \mathbb{A}_{\bar{R}} \rightarrow 0$ montre que le complexe $\text{Kos}(\varphi, G_R, \mathbb{A}_{\bar{R}})$ calcule la cohomologie galoisienne $R\Gamma(G_R, \mathbb{Z}_p)$. En résumé, le morphisme construit est

$$\begin{aligned} R\Gamma_{\text{syn}}(R, r) &\xrightarrow{\sim} \text{Syn}(R_{\text{cris}}^+, r) \xrightarrow{\sim} C(R^{[u,v]}, r) \xrightarrow{\sim} \text{Kos}(\varphi, \partial, F^r \mathbb{A}_R^{[u,v]}) \xrightarrow{\sim} \text{Kos}(\varphi, \Gamma_R, \mathbb{A}_R^{[u,v]}(r)) \\ &\xrightarrow{\sim} \text{Kos}(\varphi, \Gamma_R, \mathbb{A}_R(r)) \xleftarrow{\sim} R\Gamma(G_R, \mathbb{Z}_p(r)). \end{aligned} \quad (4)$$

Remarque 1.5. La construction du morphisme local dans le cas arithmétique traité dans [Colmez et Nizioł 2017] est similaire à celle décrite ci-dessus. Il existe cependant quelques différences que nous soulignons ici. Dans le cas où $\text{Spf}(R)$ est défini sur \mathcal{O}_K , on ne dispose plus du quasi-isomorphisme $R\Gamma_{\text{cris}}(R/\mathcal{O}_F) \cong R\Gamma_{\text{cris}}(R/\mathbb{A}_{\text{cris}})$ qui nous permet de travailler avec l’anneau R_{cris}^+ . Au lieu de cela, Colmez et Nizioł écrivent R comme le quotient d’une \mathcal{O}_F -algèbre log-lisse R_{ϖ}^+ . Cela nécessite l’introduction d’une variable supplémentaire X_0 : on définit R_{ϖ}^+ comme le relevé étale de R sur

$$\mathcal{O}_F \left\{ X_0, X_1, \dots, X_d, \frac{1}{X_1 \cdots X_a}, \frac{X_0}{X_{a+1} \cdots X_{a+b}} \right\}.$$

Le rôle de l’anneau \mathbb{A}_{inf} (respectivement $\mathbb{A}^{[u]}$ et $\mathbb{A}^{[u,v]}$) est joué par l’anneau $r_{\varpi}^+ := \mathcal{O}_F[[X_0]]$ (respectivement par l’anneau $r_{\varpi}^{[u]}$ des fonctions analytiques sur F qui convergent sur le disque $v_p(X_0) \geq u/e$, et par l’anneau $r_{\varpi}^{[u,v]}$ des fonctions analytiques sur F qui convergent sur la couronne $v/p \geq v_p(X_0) \geq u/e$). On perd, dans le cas géométrique, cette interprétation des anneaux en termes de séries de Laurent.

Travailler directement sur C permet aussi de simplifier la preuve lors du passage au complexe de Koszul. Dans le cas arithmétique, il existe deux manières différentes de plonger $R_{\varpi}^{[u]}$, $R_{\varpi}^{[u,v]}$ dans $\mathbb{A}_{\bar{R}}^{[u]}$, $\mathbb{A}_{\bar{R}}^{[u,v]}$: le plongement « de Kummer », qui envoie X_0 sur $[\varpi^b]$, et le plongement « cyclotomique » par lequel X_0 s’envoie sur un élément $\pi_K \in \mathbb{A}_{\text{inf}}(\bar{K}^b)$ tel que $\bar{\pi}_K = (\varpi_{K_m})_m$, où $(\varpi_{K_m})_m$ est une suite compatible d’uniformisantes des extensions cyclotomiques K_m de K . Les quasi-isomorphismes (3) sont obtenus en utilisant le plongement cyclotomique, mais le Frobenius qui intervient alors diffère de celui apparaissant dans la définition du complexe syntomique (qui correspond, lui, au plongement de Kummer).

Une autre différence entre la preuve arithmétique et la preuve géométrique se trouve dans les propriétés de l’inverse à gauche ψ du Frobenius. Dans [Colmez et Nizioł 2017], par construction, il est topologiquement nilpotent sur le quotient $R_{\varpi}^{[u,v]}/R_{\varpi}^{[u]}$. Colmez et Nizioł utilisent notamment cette propriété pour montrer le quasi-isomorphisme $C(R_{\varpi}^{[u]}, r) \cong C(R_{\varpi}^{[u,v]}, r)$. Ce n’est plus le cas lorsqu’on travaille avec l’anneau $R^{[u,v]}$ mais en montrant que $\psi - 1$ est surjective sur $\mathbb{A}^{[u,v]}/\mathbb{A}^{[u]}$, on obtient le quasi-isomorphisme voulu.

Enfin, dans [Colmez et Nizioł 2017], du fait de cette variable supplémentaire X_0 , l’algèbre de Lie de Γ_R n’est pas commutative. Cette difficulté n’apparaît pas dans le cas géométrique.

1C. Quasi-isomorphisme global. Si \mathfrak{X} est un schéma formel à réduction semi-stable et propre sur \mathcal{O}_K , on montre que le morphisme local du [théorème 1.3](#) se globalise en un p^N -quasi-isomorphisme

$$\alpha_r^0 : \tau_{\leq r} R\Gamma_{\text{syn}}(\mathfrak{X}_{\mathcal{O}_C}, r) \rightarrow \tau_{\leq r} R\Gamma_{\text{ét}}(\mathfrak{X}_C, \mathbb{Z}_p(r)).$$

Pour faire cela, on applique la méthode utilisée par Bhatt et al. [\[2018\]](#) (et Česnavičius et Koshikawa [\[2019, §5\]](#)). L'idée est de construire, pour $\mathfrak{X} = \text{Spf}(R)$ assez petit, une version fonctorielle des complexes intervenant en [\(4\)](#).

Pour \mathfrak{X} un schéma formel à réduction semi-stable, il existe une base $(\text{Spf}(R))$ de $\mathfrak{X}_{\mathcal{O}_C, \text{ét}}$, telle que pour chaque R on ait des ensembles finis non vides Σ et Λ tels qu'il existe une immersion fermée

$$\text{Spf}(R) \rightarrow \text{Spf}(R_{\Sigma}^{\square}) := \text{Spf}(\mathcal{O}_C \{X_{\sigma}^{\pm 1} \mid \sigma \in \Sigma\})$$

et pour chaque λ , une application étale

$$\text{Spf}(R) \rightarrow \text{Spf}(R_{\lambda}^{\square}) := \text{Spf}\left(\mathcal{O}_C \left\{ X_{\lambda,1}, \dots, X_{\lambda,d}, \frac{1}{X_{\lambda,1} \cdots X_{\lambda,a_{\lambda}}}, \frac{\varpi}{X_{\lambda,a_{\lambda}+1} \cdots X_{\lambda,d}} \right\}\right).$$

On note $\text{Spf}(R_{\Sigma, \Lambda}^{\square}) := \text{Spf}(R_{\Sigma}^{\square}) \times \prod_{\lambda \in \Lambda} \text{Spf}(R_{\lambda}^{\square})$. On construit alors une application

$$\alpha_{r, \Sigma, \Lambda} : \tau_{\leq r} \text{Kos}(\varphi, \partial, F^r R_{\Sigma, \Lambda}^{PD}) \rightarrow \tau_{\leq r} R\Gamma(G_R, \mathbb{Z}_p(r))$$

de la même façon qu'en [\(4\)](#) en remplaçant R_{cris}^+ par $R_{\Sigma, \Lambda}^{PD}$ défini sur $\mathbb{A}_{\text{cris}}(R_{\Sigma, \Lambda}^{\square})$. On déduit ensuite du [théorème 1.3](#) que $\alpha_{r, \Sigma, \Lambda}$ est un p^N -quasi-isomorphisme. On obtient des complexes fonctoriels en prenant la limite sur l'ensemble des données (Σ, Λ) comme ci-dessus. Un argument de descente cohomologique permet finalement d'obtenir le p^N -quasi-isomorphisme α_r^0 .

Remarque 1.6. Colmez et Nizioł [\[2017\]](#) construisent le p^N -quasi-isomorphisme localement, puis comparent ce morphisme à l'application de Fontaine–Messing, ce qui permet de montrer que l'application de Fontaine–Messing globale est un p^N -quasi-isomorphisme. Le même argument que celui que nous utilisons permettrait de montrer que le morphisme arithmétique admet, lui aussi, une définition globale. Il suffit de définir des anneaux $R_{\varpi, \Sigma, \Lambda}^+, R_{\varpi, \Sigma, \Lambda}^{[u]}$, ... de la même façon que nous le faisons ici.

1D. Preuve du [théorème 1.4](#). On commence par comparer les morphismes

$$\tilde{\alpha}^0, \tilde{\alpha}^{\text{FM}} : H_{\text{ét}}^i(\mathfrak{X}_C, \mathbb{Q}_p) \otimes_{\mathbb{Q}_p} \mathbb{B}_{\text{st}} \cong H_{\text{HK}}^i(\mathfrak{X}) \otimes_F \mathbb{B}_{\text{st}}.$$

Pour cela, il suffit de montrer l'égalité des morphismes

$$\alpha_r^0, \alpha_r^{\text{FM}} : \tau_{\leq r} R\Gamma_{\text{syn}}(\mathfrak{X}_{\mathcal{O}_C}, r) \rightarrow \tau_{\leq r} R\Gamma_{\text{ét}}(\mathfrak{X}_C, \mathbb{Z}_p(r)).$$

Définissons $\mathbb{E}_{\bar{R}}^{\text{PD}}$ et $\mathbb{E}_{\bar{R}}^{[u,v]}$, les anneaux log-PD-enveloppe complétés de $R_{\text{cris}}^+ \otimes_{\mathbb{A}_{\text{cris}}} \mathbb{A}_{\text{cris}}(\bar{R}) \rightarrow \mathbb{A}_{\text{cris}}(\bar{R})$ et de $R^{[u,v]} \otimes_{\mathbb{A}^{[u,v]}} \mathbb{A}_{\bar{R}}^{[u,v]} \rightarrow \mathbb{A}_{\bar{R}}^{[u,v]}$, respectivement. On note $C(G_R, M)$ le complexe des cochaines continues de G_R à valeurs dans M . Localement, α_r^{FM} est la composée des applications

$$\text{Kos}(\partial, \varphi, F^r R_{\text{cris}}^+) \rightarrow C(G_R, \text{Kos}(\partial, \varphi, F^r \mathbb{E}_{\bar{R}}^{\text{PD}})) \xleftarrow{\sim} C(G_R, \text{Kos}(\varphi, F^r \mathbb{A}_{\text{cris}}(\bar{R}))) \xleftarrow{\sim} C(G_R, \mathbb{Z}_p(r)),$$

où la deuxième flèche est un quasi-isomorphisme via le lemme de Poincaré

$$F^r \mathbb{A}_{\text{cris}}(\bar{R}) \xrightarrow{\sim} F^r \Omega_{F^r \mathbb{E}_{\bar{R}}^{\text{PD}}}^\bullet$$

et la troisième flèche se déduit de la suite exacte (1). L'application α_r^0 est donnée par la composée (4). On montre qu'il existe un diagramme commutatif

$$\begin{array}{ccccccc}
 K_{\varphi, \partial}(F^r R_{\text{cris}}^+) & \longrightarrow & C_G(K_{\varphi, \partial}(F^r \mathbb{E}_{\bar{R}}^{\text{PD}})) & \longleftarrow & C_G(K_{\varphi}(F^r \mathbb{A}_{\text{cris}}(\bar{R}))) & \longleftarrow & C_G(\mathbb{Z}_p(r)) \\
 & \searrow & \downarrow & & \downarrow & & \downarrow \\
 & & C_G(K_{\varphi, \partial}(F^r \mathbb{E}_{\bar{R}}^{[u, v]})) & \longleftarrow & C_G(K_{\varphi}(F^r \mathbb{A}_{\bar{R}}^{[u, v]})) & \longleftarrow & C_G(K_{\varphi}(\mathbb{A}_{\bar{R}}^{(0, v]^+}(r))) \longrightarrow C_G(K_{\varphi}(F^r \mathbb{A}_{\bar{R}})) \quad (5) \\
 & \searrow & \uparrow & & \uparrow & & \uparrow \\
 K_{\varphi, \partial}(F^r \mathbb{A}_{\bar{R}}^{[u, v]}) & \xrightarrow{\tau_{\leq r}} & K_{\varphi, \Gamma}(\mathbb{A}_{\bar{R}}^{[u, v]}(r)) & \longleftarrow & K_{\Gamma, \varphi}(\mathbb{A}_{\bar{R}}^{(0, v]^+}(r)) & \longrightarrow & K_{\varphi, \Gamma}(\mathbb{A}_{\bar{R}}(r))
 \end{array}$$

où, pour alléger, $C_G(\cdot)$ désigne les complexes de cochaînes et $K_{\varphi, \partial}(\cdot)$ la fibre homotopique de l'application $1 - \varphi$ sur les complexes de Koszul. On en déduit l'égalité locale. On prouve ensuite que le diagramme (5) est toujours valable pour les anneaux construits à partir des coordonnées (Σ, Λ) et en passant à la limite, on obtient l'égalité globale.

Il reste à comparer $\tilde{\alpha}^0$ et $\tilde{\alpha}^{\text{CK}}$. Pour les mêmes raisons, il suffit de montrer l'égalité des morphismes locaux. Celle-ci découle de leurs constructions. Le morphisme $\tilde{\alpha}^0$ s'obtient par la composée⁹

$$\begin{aligned}
 \tau_{\leq r} R\Gamma_{\text{ét}}\left(R\left[\frac{1}{p}\right], \mathbb{Z}_p\right)_{\mathbb{Q}} \hat{\otimes}_{\mathbb{Q}_p}^L \mathbb{B}_{\text{st}} &\xrightarrow{\sim} \tau_{\leq r} R\Gamma_{\text{ét}}\left(R\left[\frac{1}{p}\right], \mathbb{Z}_p(r)\right)_{\mathbb{Q}} \hat{\otimes}_{\mathbb{Q}_p}^L \mathbb{B}_{\text{st}}\{r\} \xrightarrow{\sim} \alpha_r^0 \tau_{\leq r} R\Gamma_{\text{syn}}(R, r)_{\mathbb{Q}} \hat{\otimes}_{\mathbb{Q}_p}^L \mathbb{B}_{\text{st}}\{r\} \\
 &\xrightarrow{\sim} \tau_{\leq r} R\Gamma_{\text{cris}}(R/\mathbb{A}_{\text{cris}})_{\mathbb{Q}} \hat{\otimes}_{\mathbb{A}_{\text{cris}}[1/p]}^L \mathbb{B}_{\text{st}} \xleftarrow{\sim} \tau_{\leq r} R\Gamma_{\text{HK}}(R) \hat{\otimes}_F^L \mathbb{B}_{\text{st}}, \quad (6)
 \end{aligned}$$

où

$$\iota_{\text{cris}, \varpi}^{\text{B}} : R\Gamma_{\text{cris}}((R/p)/W(k)^0) \hat{\otimes}_{W(k)}^L \mathbb{B}_{\text{st}}^+ \xrightarrow{\sim} R\Gamma_{\text{cris}}((R/p)/\mathbb{A}_{\text{cris}}) \hat{\otimes}_{\mathbb{A}_{\text{cris}}}^L \mathbb{B}_{\text{st}}^+$$

est le quasi-isomorphisme (qui dépend du ϖ choisi) de [Beilinson 2013, (1.18.5)]. Rappelons maintenant comment $\tilde{\alpha}^{\text{CK}}$ est défini. La preuve de [Česnavičius et Koshikawa 2019] passe par la construction d'un complexe $A\Omega_R \in D^+(\text{Spf}(R))_{\text{ét}, \mathbb{A}_{\text{inf}}}$ (voir le théorème 2.3 de leur article) qui vérifie

$$R\Gamma_{\text{ét}}\left(R\left[\frac{1}{p}\right], \mathbb{Z}_p\right) \hat{\otimes}_{\mathbb{Z}_p}^L \left(\mathbb{A}_{\text{inf}}\left[\frac{1}{\mu}\right]\right) \xrightarrow{\sim} R\Gamma_{\text{ét}}(R, A\Omega_R) \hat{\otimes}_{\mathbb{A}_{\text{inf}}}^L \left(\mathbb{A}_{\text{inf}}\left[\frac{1}{\mu}\right]\right), \quad (7)$$

où $\mu = [\varepsilon] - 1 \in \mathbb{A}_{\text{inf}}$. On obtient ensuite $\tilde{\alpha}^{\text{CK}}$ en construisant un quasi-isomorphisme

$$\gamma_{\text{CK}} : Ru_*(\mathcal{O}_{(R/p)/\mathbb{A}_{\text{cris}}}) \xrightarrow{\sim} A\Omega_R \hat{\otimes}_{\mathbb{A}_{\text{inf}}}^L \mathbb{A}_{\text{cris}}$$

9. Si M est un module muni d'une action d'un Frobenius φ , on note $M\{r\}$ le module M muni de l'action du Frobenius $p^r \varphi$. Voir la section [Notations et conventions](#) pour la définition de $-\hat{\otimes}^L$ - utilisée ici.

où $\mathcal{O}_{(R/p)/\mathbb{A}_{\text{cris}}} \in ((R/p)/\mathbb{A}_{\text{cris}})_{\text{log-cris}}$ désigne le faisceau structural sur le site cristallin et u est la projection $((R/p)/\mathbb{A}_{\text{cris}})_{\text{log-cris}} \rightarrow (\text{Spf}(R))_{\text{ét}}$. Pour cela, Česnavičius et Koshikawa commencent par montrer qu'on peut calculer $A\Omega_R$ comme $L\eta_\mu R\Gamma(\Gamma_R, \mathbb{A}_{\text{inf}}(R_\infty))$ où η_μ est le foncteur de décalage de Berthelot–Ogus [Bhatt et al. 2018]. Pour définir γ_{CK} , il reste à construire un quasi-isomorphisme entre $\text{Kos}(\partial, R_{\text{inf}}^+)$ et $\eta_\mu \text{Kos}(\Gamma_R, \mathbb{A}_{\text{inf}}(R_\infty)) \widehat{\otimes}_{\mathbb{A}_{\text{inf}}}^L \mathbb{A}_{\text{cris}}$. Ce passage entre la cohomologie d'une algèbre de Lie et la cohomologie de groupe est similaire à celui apparaissant dans la construction de α_r^0 , avec μ jouant le rôle de t , et c'est ce qui permet d'obtenir un diagramme commutatif

$$\begin{array}{ccc} \tau_{\leq r} R\Gamma_{\text{ét}}(R, A\Omega_R)_{\mathbb{Q}} \widehat{\otimes}_{\mathbb{A}_{\text{inf}}[1/p]}^L \mathbb{B}_{\text{st}} & \xleftarrow{\sim \gamma_{\text{CK}}} & \tau_{\leq r} R\Gamma_{\text{cris}}(R/\mathbb{A}_{\text{cris}})_{\mathbb{Q}} \widehat{\otimes}_{\mathbb{A}_{\text{cris}}[1/p]}^L \mathbb{B}_{\text{st}} \\ \uparrow & & \uparrow \\ \tau_{\leq r} R\Gamma_{\text{ét}}(R[\frac{1}{p}], \mathbb{Z}_p(r))_{\mathbb{Q}} \widehat{\otimes}_{\mathbb{Q}_p}^L \mathbb{B}_{\text{st}}\{r\} & \xleftarrow{\sim \alpha_r^0} & \tau_{\leq r} R\Gamma_{\text{syn}}(R, r)_{\mathbb{Q}} \widehat{\otimes}_{\mathbb{Q}_p}^L \mathbb{B}_{\text{st}}\{r\} \end{array} \quad (8)$$

Finalement, $\tilde{\alpha}^{\text{CK}}$ est donnée par la composée

$$R\Gamma_{\text{ét}}\left(R\left[\frac{1}{p}\right], \mathbb{Z}_p\right)_{\mathbb{Q}} \widehat{\otimes}_{\mathbb{Q}_p}^L \mathbb{B}_{\text{st}} \xrightarrow{\sim (7)} R\Gamma_{\text{ét}}(R, A\Omega_R)_{\mathbb{Q}} \widehat{\otimes}_{\mathbb{A}_{\text{inf}}[1/p]}^L \mathbb{B}_{\text{st}} \xleftarrow{\sim \gamma_{\text{CK}}} R\Gamma_{\text{cris}}(R/\mathbb{A}_{\text{cris}})_{\mathbb{Q}} \widehat{\otimes}_{\mathbb{A}_{\text{cris}}[1/p]}^L \mathbb{B}_{\text{st}} \xleftarrow{\sim \begin{smallmatrix} \mathbb{B} \\ \text{cris}, \varpi \end{smallmatrix}}} R\Gamma_{\text{HK}}(R) \widehat{\otimes}_{\mathbb{F}}^L \mathbb{B}_{\text{st}}, \quad (9)$$

et le diagramme (8) permet d'obtenir l'égalité entre (9) et (6).

Notations et conventions. Pour N un entier, on dit qu'une application $f : A \rightarrow B$ est p^N -injective (respectivement p^N -surjective) si son noyau (respectivement son conoyau) est tué par p^N . Le morphisme f est un p^N -isomorphisme s'il est à la fois p^N -injectif et p^N -surjectif. La suite

$$0 \rightarrow A \xrightarrow{i} B \xrightarrow{f} C \xrightarrow{g} 0$$

est p^N -exacte si i est p^N -injective, $\text{Im}(g) = p^N \ker(f)$ et g est p^N -surjective. On définit de même un p^N -quasi-isomorphisme comme étant une application $f : A^\bullet \rightarrow B^\bullet$ dans la catégorie dérivée qui induit un p^N -isomorphisme sur la cohomologie.

Dans tout l'article, on utilise les résultats de [Diao et al. 2019] sur les log-espaces adiques. On utilise en particulier que le foncteur usuel des schémas formels localement noethériens dans les espaces adiques s'étend en un foncteur pleinement fidèle des log-schémas formels localement noethériens dans la catégorie des log-espaces adiques localement noethériens [Diao et al. 2019, Proposition 2.2.22].

Si T est un topos et A un anneau, on note $\mathcal{D}^+(T, A)$ (respectivement $\mathcal{D}^+(A)$) l' ∞ -catégorie dérivée des faisceaux de A -modules sur T inférieurement bornés (respectivement l' ∞ -catégorie dérivée des A -modules). Les catégories homotopiques associées sont les catégories dérivées $D^+(T, A)$ et $D^+(A)$. Le foncteur dérivé $R\Gamma(-) : D^+(T, A) \rightarrow D^+(A)$ se relève en un foncteur $R\Gamma(-) : \mathcal{D}^+(T, A) \rightarrow \mathcal{D}^+(A)$. On note aussi $\mathbf{Fsc}(T, \mathcal{D}^+(A))$ la catégorie des faisceaux de $\mathcal{D}^+(A)$ sur T et on identifie les ∞ -catégories $\mathcal{D}^+(T, A)$ et $\mathbf{Fsc}(T, \mathcal{D}^+(A))$.

Si $f : K^\bullet \rightarrow L^\bullet$ est un morphisme de $\mathcal{D}^+(T, A)$, on note $[K^\bullet \xrightarrow{f} L^\bullet] := \text{holim}(K^\bullet \rightarrow L^\bullet \leftarrow 0)$ la fibre d'homotopie de l'application f .

Pour $A \rightarrow B$ un morphisme d'anneaux et K^\bullet et L^\bullet des objets de $\mathcal{D}(A)$, on note

$$K^\bullet \widehat{\otimes}_A^L L^\bullet := \text{holim}_n((K^\bullet \otimes_A^L L^\bullet) \otimes_{\mathbb{Z}} \mathbb{Z}/p^n \mathbb{Z}) \quad \text{et} \quad (K^\bullet)_{\mathbb{Q}} \widehat{\otimes}_A^L B := (\text{holim}_n((K^\bullet \otimes_A^L B) \otimes_{\mathbb{Z}} \mathbb{Z}/p^n \mathbb{Z})) \otimes_{\mathbb{Q}} p.$$

Plus généralement, si $J = (f_1, \dots, f_r)$ est un idéal finiment engendré de A , on définit le produit tensoriel dérivé complété pour la topologie J -adique :

$$K^\bullet \widehat{\otimes}_A^L L^\bullet := \text{holim}_n((K^\bullet \otimes_A^L L^\bullet) \otimes_{\mathbb{Z}} \mathbb{Z}[f_1, \dots, f_r]/(f_1^n, \dots, f_r^n)),$$

$$(K^\bullet)_{\mathbb{Q}} \widehat{\otimes}_A^L B := (\text{holim}_n((K^\bullet \otimes_A^L B) \otimes_{\mathbb{Z}} \mathbb{Z}[f_1, \dots, f_r]/(f_1^n, \dots, f_r^n))) \otimes_{\mathbb{Q}} p.$$

Si G est un groupe qui agit sur un module M , on notera $R\Gamma(G, M)$ la cohomologie de groupe *continue* associée.

Si \mathcal{O}_K est un anneau de valuation discrète en caractéristique mixte $(0, p)$ et ϖ une uniformisante de \mathcal{O}_K , on dira respectivement qu'un schéma ou schéma formel est à *réduction semi-stable* sur \mathcal{O}_K s'il s'écrit localement pour la topologie étale $\text{Spec}(R)$ ou $\text{Spf}(R)$ avec R une algèbre étale sur

$$\mathcal{O}_K \left[X_1, \dots, X_d, \frac{1}{X_1 \cdots X_a}, \frac{\varpi}{X_{a+1} \cdots X_{a+b}} \right] \quad \text{ou} \quad \mathcal{O}_K \left\{ X_1, \dots, X_d, \frac{1}{X_1 \cdots X_a}, \frac{\varpi}{X_{a+1} \cdots X_{a+b}} \right\},$$

avec a, b et d des entiers tels que $a + b \leq d$. Enfin, si A est un anneau de valuation discrète, on notera A^\times le log-schéma formel $\text{Spf}(A)$ muni de la log-structure induite par son point fermé (appelée log-structure standard de A) : c'est la log-structure donnée par l'inclusion $A \setminus \{0\} \hookrightarrow A$. On notera A^0 le log-schéma formel $\text{Spf}(A)$ muni de la log-structure induite par $(\mathbb{N} \rightarrow A, 1 \mapsto 0)$.

2. Cohomologie syntomique et résultat local

Dans cette section, on commence par donner les définitions des faisceaux syntomiques arithmétique $\mathcal{S}_n(r)_{\mathfrak{X}}$ et géométrique $\mathcal{S}_n(r)_{\overline{\mathfrak{X}}}$. On décrit ensuite la forme locale de ces complexes.

2A. Définition de la cohomologie syntomique. On considère \mathfrak{X} un schéma formel à réduction semi-stable sur \mathcal{O}_K , i.e., localement \mathfrak{X} s'écrit $\text{Spf}(R)$ avec R la complétion d'une algèbre étale sur

$$\mathcal{O}_K \left\{ X_1, \dots, X_d, \frac{1}{X_1 \cdots X_a}, \frac{\varpi}{X_{a+1} \cdots X_{a+b}} \right\}$$

avec a, b, c et d des entiers tels que $a + b + c = d$. On munit \mathfrak{X} de la log-structure donnée par $\mathcal{M} := \{g \in \mathcal{O}_X \mid g \text{ inversible en dehors de } D \cup \mathfrak{X}_k\}$ où D est le diviseur horizontal et on a alors que \mathfrak{X} est log-lisse sur \mathcal{O}_K^\times . On note $\mathfrak{X}_{K, \text{tr}}$ le lieu de \mathfrak{X}_K où la log-structure est triviale : si $\mathfrak{X} = \text{Spf}(R)$ alors $\mathfrak{X}_{K, \text{tr}} = \text{Sp}(R_K) \setminus D_K$. On appelle i (respectivement j) l'immersion $\mathfrak{X}_k \hookrightarrow \mathfrak{X}$ (respectivement le morphisme de topoi étales $\mathfrak{X}_{K, \text{tr}, \text{ét}} \rightarrow \mathfrak{X}_{\text{ét}}$) et $\bar{i} : \mathfrak{X}_{\bar{k}} \hookrightarrow \mathfrak{X}_{\mathcal{O}_C}$ (respectivement $\bar{j} : \mathfrak{X}_{C, \text{tr}} \rightarrow \mathfrak{X}_{\mathcal{O}_C}$) le changement de base associé. Enfin, pour n dans \mathbb{N} , on note \mathfrak{X}_n la réduction de \mathfrak{X} modulo p^n .

On note $R\Gamma_{\text{cris}}(\mathfrak{X}_n) := R\Gamma_{\text{cris}}(\mathfrak{X}_n/W_n(k))$ la cohomologie cristalline absolue de \mathfrak{X}_n et $R\Gamma_{\text{cris}}(\mathfrak{X}) := \text{holim}_n R\Gamma_{\text{cris}}(\mathfrak{X}_n)$. On note $\mathcal{O}_{\mathfrak{X}_n/W_n(k)}$ le faisceau structurel du site cristallin $(\mathfrak{X}_n/W_n(k))_{\text{cris}}$, $\mathcal{J}_n = \ker(\mathcal{O}_{\mathfrak{X}_n/W_n(k)} \rightarrow \mathcal{O}_{\mathfrak{X}_n})$ et $\mathcal{J}_n^{[r]}$ sa r -ième puissance divisée. On définit ensuite

$$R\Gamma_{\text{cris}}(\mathfrak{X}, \mathcal{J}^{[r]})_n := R\Gamma(\mathfrak{X}_{\text{ét}}, Ru_{n*}\mathcal{J}_n^{[r]}) \quad \text{et} \quad R\Gamma_{\text{cris}}(\mathfrak{X}, \mathcal{J}^{[r]}) := \text{holim}_n R\Gamma_{\text{cris}}(\mathfrak{X}, \mathcal{J}^{[r]})_n$$

où u_n est la projection $(\mathfrak{X}_n/W_n(k))_{\text{cris}} \rightarrow \mathfrak{X}_{\text{ét}}$. On a alors les complexes syntomiques

$$R\Gamma_{\text{syn}}(\mathfrak{X}, r)_n := [R\Gamma_{\text{cris}}(\mathfrak{X}, \mathcal{J}^{[r]})_n \xrightarrow{p^r - \varphi} R\Gamma_{\text{cris}}(\mathfrak{X}_n)] \quad \text{et} \quad R\Gamma_{\text{syn}}(\mathfrak{X}, r) := \text{holim}_n R\Gamma_{\text{syn}}(\mathfrak{X}, r)_n,$$

où φ désigne le morphisme de Frobenius. Enfin, on note $\mathcal{S}_n(r)_{\mathfrak{X}}$ le faisceau de $\mathcal{D}^+(\mathfrak{X}_k)_{\text{ét}}, \mathbb{Z}/p^n\mathbb{Z}$ associé au préfaisceau $U \mapsto R\Gamma_{\text{syn}}(U, r)_n$.

On définit de même la version géométrique $\mathcal{S}_n(r)_{\bar{\mathfrak{X}}}$ de ce faisceau (i.e., sur \mathcal{O}_C).

Remarque 2.1. Dans la suite, on trouvera utile la description suivante, plus explicite, de la cohomologie syntomique. Considérons un log-schéma formel \mathfrak{X} à réduction semi-stable sur $\text{Spf}(\mathcal{O}_C)$ et notons Y sa fibre spéciale. On choisit \mathfrak{U}^\bullet un hyper-recouvrement de \mathfrak{X} pour la topologie étale. Soit $\{Z_n^\bullet\}$ un système inductif de log-schémas log-lisses simpliciaux sur \mathbb{A}_{cris} tels qu'on ait des immersions fermées $\mathfrak{U}_n^\bullet \hookrightarrow Z_n^\bullet$ et des relèvements $\varphi_{Z_n^\bullet}$ du Frobenius. On note D_n^s la log-PD-enveloppe de \mathfrak{U}_n^s dans Z_n^s , $J_{D_n^s}$ l'idéal associé et $J_{D_n^s}^{[r]}$ sa r -ième puissance divisée. Pour chaque s , on définit le faisceau $\mathcal{S}_n(r)_{\mathfrak{U}^s, Z^s, \varphi^s}$ de $D(Y_{\text{ét}}, \mathbb{Z}/p^n\mathbb{Z})$ par

$$\mathcal{S}_n(r)_{\mathfrak{U}^s, Z^s, \varphi^s} := [J_{D_n^s}^{[r-\bullet]} \otimes_{\mathcal{O}_{Z_n^s}} \omega_{Z_n^\bullet} \xrightarrow{p^r - \varphi} \mathcal{O}_{D_n^s} \otimes_{\mathcal{O}_{Z_n^s}} \omega_{Z_n^s}^\bullet],$$

où $\omega_{Z_n^\bullet}^\bullet$ est le complexe des log-différentielles de Z_n^\bullet . On note $R\Gamma_{\text{syn}}((\mathfrak{U}^\bullet, Z^\bullet, \varphi^\bullet), r)_n$ l'hypercohomologie associée, utilisant ici la définition 6.10 de [Conrad 2003]. En particulier (voir le théorème 6.11 de ce dernier article), on a une suite spectrale

$$E_1^{p,q} := H_{\text{syn}}^q((\mathfrak{U}^p, Z^p, \varphi^p), r)_n \implies H_{\text{syn}}^{p+q}((\mathfrak{U}^\bullet, Z^\bullet, \varphi^\bullet), r)_n. \quad (10)$$

On note $\text{HRF}(\mathfrak{X})$ la catégorie dont les objets sont donnés par les triplets $(\mathfrak{U}^\bullet, \{Z_n^\bullet\}, \{\varphi_n^\bullet\})$ où $\mathfrak{U}^\bullet \rightarrow \mathfrak{X}$ est un hyper-recouvrement et les $\{Z_n^\bullet\}$ et $\{\varphi_n^\bullet\}$ sont définis comme ci-dessus. On abrégera par \mathfrak{U}^\bullet un tel triplet. Un morphisme $(\mathfrak{U}^\bullet, \{Z_{\mathfrak{U},n}^\bullet\}, \{\varphi_{\mathfrak{U},n}^\bullet\}) \rightarrow (\mathfrak{V}^\bullet, \{Z_{\mathfrak{V},n}^\bullet\}, \{\varphi_{\mathfrak{V},n}^\bullet\})$ de $\text{HRF}(\mathfrak{X})$ est une paire $(u : \mathfrak{U}^\bullet \rightarrow \mathfrak{V}^\bullet, \tilde{u}_n : Z_{\mathfrak{U},n}^\bullet \rightarrow Z_{\mathfrak{V},n}^\bullet)$ telle que, pour tout s , le diagramme

$$\begin{array}{ccc} Z_{\mathfrak{U},n}^s & \xrightarrow{\tilde{u}_n} & Z_{\mathfrak{V},n}^s \\ \uparrow & & \uparrow \\ \mathfrak{U}^s & \xrightarrow{u} & \mathfrak{V}^s \end{array}$$

commute, et telle que les \tilde{u}_n commutent avec les φ_n^s . Il est alors possible de considérer la limite $\text{hocolim}_{\text{HRF}(\mathfrak{X})} R\Gamma_{\text{syn}}((\mathfrak{U}^\bullet, Z^\bullet, \varphi^\bullet), r)_n$; les morphismes de transition sont des quasi-isomorphismes. Comme le morphisme $\mathfrak{U}^\bullet \rightarrow \mathfrak{X}$ est de descente cohomologique (voir [Conrad 2003, Exemple 6.9]), on

a un quasi-isomorphisme [Conrad 2003, Corollary 7.11]

$$R\Gamma_{\text{syn}}(\mathfrak{X}, r)_n \xrightarrow{\sim} \text{hocolim}_{\text{HRF}(\mathfrak{X})} R\Gamma_{\text{syn}}((\mathcal{U}^\bullet, Z^\bullet, \varphi^\bullet), r)_n, \tag{11}$$

et cette colimite est filtrée.

2B. Résultat local. On va supposer $\mathfrak{X}_{\mathcal{O}_C} = \text{Spf}(R)$.

2B1. Résultat préliminaire. La proposition suivante est donnée dans [Colmez et Nizioł 2017, §2.1]. On l'utilise pour définir un morphisme de Frobenius sur les anneaux utilisés. On considère $\lambda : \Lambda_1 \rightarrow \Lambda_2$ un morphisme d'anneaux topologiques et Λ'_1 la complétion d'une Λ_1 -algèbre étale

$$\Lambda'_1 := \Lambda_1\{Z_1, \dots, Z_s\}/(Q_1, \dots, Q_s)$$

avec $J := (\partial Q_j / \partial Z_i)_{1 \leq i, j \leq s}$ inversible.

Notation. Pour $F = \sum_{\mathbf{k} \in \mathbb{N}^s} a_{\mathbf{k}} Z^{\mathbf{k}}$ une série dans un anneau $\Lambda_1\{Z\}$, on note F^λ la série $\sum_{\mathbf{k} \in \mathbb{N}^s} \lambda(a_{\mathbf{k}}) Z^{\mathbf{k}}$.

Proposition 2.2 [Colmez et Nizioł 2017, Proposition 2.1 et Remark 2.2]. *On suppose qu'il existe Z_λ dans Λ_2^s et I un idéal de Λ_2 tels que Λ_2 est séparé et complet pour la topologie I -adique et tels que les coordonnées de $Q^\lambda(Z_\lambda)$ sont dans I . Alors l'équation $Q^\lambda(Y) = 0$ admet une unique solution dans $Z_\lambda + I^s$ et on peut étendre λ de manière unique à Λ'_1 .*

2B2. Modèles locaux. On munit $\text{Spf}(\mathcal{O}_C)$ de la log-structure standard $\mathcal{O}_C \setminus \{0\} \hookrightarrow \mathcal{O}_C$ et on note \mathcal{O}_C^\times ce log-schéma formel. On note

$$R_\square := \mathcal{O}_C \left\{ X, \frac{1}{X_1 \cdots X_a}, \frac{\varpi}{X_{a+1} \cdots X_{a+b}} \right\}$$

où $X = (X_1, \dots, X_d)$ et on considère R la complétion p -adique d'une algèbre étale sur R_\square . On munit $\text{Spf}(R_\square)$ et $\text{Spf}(R)$ de la structure logarithmique induite par la fibre spéciale et le diviseur $D := \{X_{a+b+1} \cdots X_d = 0\}$.

Remarque 2.3. Les log-structures décrites ci-dessus ne sont pas fines, mais de la même façon que dans [Česnavičius et Koshikawa 2019], on peut, via un changement de base, se ramener à des log-structures fines, et de cette façon, travailler avec les log-structures précédentes comme si elles étaient fines. Plus précisément, munissons $\text{Spf}(\mathcal{O}_C)$ et $\text{Spf}(R)$ des log-structures fines suivantes (voir [Česnavičius et Koshikawa 2019, §1.6]) :

- Sur $\text{Spf}(R)$, on considère la log-structure donnée par la carte

$$\mathbb{N}^{d-a} \rightarrow \Gamma(\text{Spf}(R), \mathcal{O}_{\text{Spf}(R)})$$

donnée par $(n_i) \mapsto \prod_{a+1 \leq i \leq d} X_i^{n_i}$ sur \mathbb{N}^{d-a} .

- Sur $\text{Spf}(\mathcal{O}_C)$, on considère la log-structure donnée par la carte

$$\mathbb{N} \rightarrow \mathcal{O}_C, \quad n \mapsto \varpi^n.$$

Les changements de base le long des applications

$$\mathbb{N}^{d-a} \rightarrow \mathcal{O}_{\text{Spf}(R)} \cap \bar{J}_*(\mathcal{O}_{\text{Sp}(R[1/p]) \setminus D_C}^*), (n_i) \mapsto X_i^{n_i} \quad \text{et} \quad \mathbb{N} \rightarrow \mathcal{O}_C \setminus \{0\}, n \mapsto \varpi^n$$

permettent de retrouver les log-structures précédentes. La plupart des propriétés des morphismes de log-schémas (formels) étant stables par changement de base, on se ramène de cette façon à des log-structures fines.

Si, pour tout $n \geq 0$, on munit \mathcal{O}_C/p^n et R/p^n des log-structures induites, alors R/p^n est log-lisse sur \mathcal{O}_C/p^n , de sorte que le complexe des log-différentielles $\Omega_{(R/p^n)/(\mathcal{O}_C/p^n)}^i$ est le \mathcal{O}/p^n -module engendré par les dX_i/X_i pour $1 \leq i \leq d$.

On considère les anneaux de Fontaine \mathbb{A}_{inf} et \mathbb{A}_{cris} et on rappelle qu'on a les éléments

$$\varepsilon = (1, \zeta_p, \zeta_{p^2}, \dots) \in \mathcal{O}_C^b,$$

où ζ_{p^n} désigne une racine primitive p^n -ième de l'unité, ainsi que

$$\mu = [\varepsilon] - 1 \in \mathbb{A}_{\text{inf}}, \quad \xi = \frac{\mu}{\varphi^{-1}(\mu)} \in \mathbb{A}_{\text{inf}}, \quad t = \log(1 + \mu) \in \mathbb{A}_{\text{cris}}.$$

On a une application surjective $\theta : \mathbb{A}_{\text{cris}} \rightarrow \mathcal{O}_C$ de noyau engendré par ξ . On note $F^r \mathbb{A}_{\text{cris}}$ la filtration sur \mathbb{A}_{cris} donnée par les puissances divisées de ξ .

On munit \mathbb{A}_{cris} de la log-structure associée à la pré-log-structure

$$\mathcal{O}_C^b \setminus \{0\} \rightarrow \mathbb{A}_{\text{cris}}, \quad x \mapsto [x],$$

et les $\mathbb{A}_{\text{cris}}/p^n$ de la log-structure tirée en arrière. En fait, cette log-structure est l'unique log-structure sur $\mathbb{A}_{\text{cris}}/p^n$ qui étend celle de \mathcal{O}_C/p^n ; voir [Beilinson 2013, § 1.17]. Enfin, on munit \mathbb{A}_{inf} de la log-structure venant de celle de \mathbb{A}_{cris} .

On définit

$$R_{\text{inf}, \square}^+ := \mathbb{A}_{\text{inf}} \left\{ X, \frac{1}{X_1 \cdots X_a}, \frac{[\varpi^b]}{X_{a+1} \cdots X_{a+b}} \right\}.$$

L'anneau $R_{\text{inf}, \square}^+$ est complet pour la topologie (p, ξ) -adique. On va relever $R_{\square} \rightarrow R$ en un morphisme étale $R_{\text{inf}, \square}^+ \rightarrow R_{\text{inf}}^+$. Pour cela, on écrit $R := R_{\square} \{Z_1, \dots, Z_s\} / (Q_1, \dots, Q_s)$ avec $\det(\partial Q_j / \partial Z_i)$ inversible dans R . Soient \tilde{Q}_j des relevés des Q_j dans $R_{\text{inf}, \square}^+$. On note R_{inf}^+ la complétion (p, ξ) -adique de

$$R_{\text{inf}, \square}^+ [Z_1, \dots, Z_s] / (\tilde{Q}_1, \dots, \tilde{Q}_s)$$

et $\det(\partial \tilde{Q}_j / \partial Z_i)$ est inversible dans $R_{\text{inf}, \square}^+$ (car il l'est modulo ξ et $R_{\text{inf}, \square}^+$ est ξ -adiquement complet).

On note $R_{\text{cris}, \square}^+$ et R_{cris}^+ les anneaux $R_{\text{inf}, \square}^+ \hat{\otimes}_{\mathbb{A}_{\text{inf}}} \mathbb{A}_{\text{cris}}$ et $R_{\text{inf}}^+ \hat{\otimes}_{\mathbb{A}_{\text{inf}}} \mathbb{A}_{\text{cris}}$, où les produits tensoriels sont complétés pour la topologie p -adique. L'anneau R_{cris}^+ admet une filtration donnée par $F^r R_{\text{cris}}^+ := R_{\text{inf}}^+ \hat{\otimes}_{\mathbb{A}_{\text{inf}}} F^r \mathbb{A}_{\text{cris}}$.

On a le diagramme commutatif

$$\begin{array}{ccc}
 \mathrm{Spf}(R) & \hookrightarrow & \mathrm{Spf}(R_{\mathrm{cris}}^+) \\
 \downarrow & & \downarrow \\
 \mathrm{Spf}(R_{\square}) & \hookrightarrow & \mathrm{Spf}(R_{\mathrm{cris},\square}^+) \\
 \downarrow & & \downarrow \\
 \mathrm{Spf}(\mathcal{O}_C) & \hookrightarrow & \mathrm{Spf}(\mathbb{A}_{\mathrm{cris}})
 \end{array}$$

On définit une log-structure sur $\mathrm{Spf}(R_{\mathrm{inf},\square}^+)$ et $\mathrm{Spf}(R_{\mathrm{cris},\square}^+)$ en ajoutant à la log-structure venant respectivement de $\mathrm{Spf}(\mathbb{A}_{\mathrm{inf}})$ et $\mathrm{Spf}(\mathbb{A}_{\mathrm{cris}})$ le diviseur à l'infini $\{X_{a+b+1} \cdots X_d = 0\}$. On munit R_{inf}^+ et R_{cris}^+ de la log-structure venant respectivement de $R_{\mathrm{inf},\square}^+$ et $R_{\mathrm{cris},\square}^+$.

Comme ci-dessus, on a alors que les complexes des log-différentielles de R_{inf}^+ et de R_{cris}^+ sur $\mathbb{A}_{\mathrm{inf}}$ et $\mathbb{A}_{\mathrm{cris}}$ sont, respectivement, le $\mathbb{A}_{\mathrm{inf}}$ -module et le $\mathbb{A}_{\mathrm{cris}}$ -module engendrés par les dX_i/X_i pour $1 \leq i \leq d$.

On note R_{inf} et R_{cris} les complétions p -adiques de $R_{\mathrm{inf}}^+[1/[\varpi^b]]$ et de $R_{\mathrm{cris}}^+[1/[\varpi^b]]$.

2B3. Complexe syntomique local. On va commencer par prouver une version locale du [théorème 1.1](#). On suppose donc que \mathfrak{X} s'écrit $\mathrm{Spf}(R_0)$ avec R_0 la complétion p -adique d'une algèbre étale sur

$$\mathcal{O}_K \left\{ X_1, \dots, X_d, \frac{1}{X_1 \cdots X_a}, \frac{\varpi}{X_{a+1} \cdots X_{a+b}} \right\}$$

et on écrit $\mathfrak{X}_{\mathcal{O}_C} := \mathrm{Spf}(R)$. Dans la suite, on note

$$R_{\square} := \mathcal{O}_C \left\{ X_1, \dots, X_d, \frac{1}{X_1 \cdots X_a}, \frac{\varpi}{X_{a+1} \cdots X_{a+b}} \right\}.$$

On utilise les log-structures définies dans la partie précédente.

Via les quasi-isomorphismes montrés par Beilinson [\[2013, \(1.18.1\)\]](#),

$$\begin{aligned}
 R\Gamma((\bar{\mathfrak{X}}_n/W_n(\bar{k}))_{\mathrm{cris}}, \mathcal{F}) &\simeq R\Gamma((\bar{\mathfrak{X}}_n/\mathbb{A}_{\mathrm{cris},n})_{\mathrm{cris}}, \mathcal{F}), \\
 R\Gamma((\bar{\mathfrak{X}}/W(\bar{k}))_{\mathrm{cris}}, \mathcal{F}) &\simeq R\Gamma((\bar{\mathfrak{X}}/\mathbb{A}_{\mathrm{cris}})_{\mathrm{cris}}, \mathcal{F}),
 \end{aligned} \tag{12}$$

on obtient que la cohomologie cristalline absolue de $\bar{\mathfrak{X}}_n$ et sa filtration en degré r sont calculées par les complexes $R\Gamma((\bar{\mathfrak{X}}_n/\mathbb{A}_{\mathrm{cris},n})_{\mathrm{cris}}, \mathcal{O})$ et $R\Gamma((\bar{\mathfrak{X}}_n/\mathbb{A}_{\mathrm{cris},n})_{\mathrm{cris}}, \mathcal{J}^{[r]})$. Comme $\tilde{\mathfrak{X}} := \mathrm{Spf}(R_{\mathrm{cris}}^+)$ est un relèvement log-lisse de \mathfrak{X} sur $\mathbb{A}_{\mathrm{cris}}$ et que $\mathfrak{X} \hookrightarrow \tilde{\mathfrak{X}}$ est exacte, on obtient des quasi-isomorphismes naturels

$$R\Gamma((\bar{\mathfrak{X}}_n/\mathbb{A}_{\mathrm{cris},n})_{\mathrm{cris}}, \mathcal{O}) \cong \Omega_{R_{\mathrm{cris},n}^+}^\bullet \quad \text{et} \quad R\Gamma((\bar{\mathfrak{X}}_n/\mathbb{A}_{\mathrm{cris},n})_{\mathrm{cris}}, \mathcal{J}^{[r]}) \cong F^r \Omega_{R_{\mathrm{cris},n}^+}^\bullet,$$

où $R_{\mathrm{cris},n}^+$ est la réduction modulo p^n de R_{cris}^+ et

$$F^r \Omega_{R_{\mathrm{cris},n}^+}^\bullet := F^r R_{\mathrm{cris},n}^+ \rightarrow F^{r-1} \Omega_{R_{\mathrm{cris},n}^+}^1 \rightarrow F^{r-2} \Omega_{R_{\mathrm{cris},n}^+}^2 \rightarrow \cdots.$$

En particulier, $R\Gamma_{\text{cris}}(\mathfrak{X}, \mathcal{J}^{[r]}) \cong F^r \Omega_{R_{\text{cris}}^+}^\bullet$ et $R\Gamma_{\text{cris}}(\mathfrak{X}) \cong \Omega_{R_{\text{cris}}^+}^\bullet$, et on en déduit que $R\Gamma_{\text{syn}}(\mathfrak{X}_{\mathcal{O}_C}, r)$ et $R\Gamma_{\text{syn}}(\mathfrak{X}_{\mathcal{O}_C}, r)_n$ sont calculés par les complexes

$$\text{Syn}(R_{\text{cris}}^+, r) := [F^r \Omega_{R_{\text{cris},n}^+}^\bullet \xrightarrow{p^r - \varphi} \Omega_{R_{\text{cris},n}^+}^\bullet] \quad \text{et} \quad \text{Syn}(R_{\text{cris}}^+, r)_n := [F^r \Omega_{R_{\text{cris},n}^+}^\bullet \xrightarrow{p^r - \varphi} \Omega_{R_{\text{cris},n}^+}^\bullet].$$

Soit \bar{R} l'extension maximale de R telle que $\bar{R}[1/p]/R[1/p]$ est non ramifiée en dehors de D . On note $G_R := \text{Gal}(\bar{R}[1/p]/R[1/p])$ le groupe des automorphismes de $\bar{R}[1/p]$ qui fixent $R[1/p]$. Le but des sections suivantes est de montrer la version géométrique du théorème 4.14 de [Colmez et Nizioł 2017] :

Théorème 2.4. *Il existe des p^N -quasi-isomorphismes*

$$\begin{aligned} \alpha_r^0 : \tau_{\leq r} \text{Syn}(R_{\text{cris}}^+, r) &\xrightarrow{\sim} \tau_{\leq r} R\Gamma(G_R, \mathbb{Z}_p(r)), \\ \alpha_{r,n}^0 : \tau_{\leq r} \text{Syn}(R_{\text{cris}}^+, r)_n &\xrightarrow{\sim} \tau_{\leq r} R\Gamma(G_R, \mathbb{Z}/p^n(r)), \end{aligned}$$

où N est une constante qui ne dépend que de r .

Remarque 2.5. On verra plus loin que ce résultat implique le théorème global 1.1. Dans le cas où $\mathfrak{X}_{\mathcal{O}_C} := \text{Spf}(R)$ n'a pas de diviseur horizontal, la cohomologie de Galois $R\Gamma(G_R, \mathbb{Z}/p^n\mathbb{Z}(r))$ calcule la cohomologie étale $R\Gamma_{\text{ét}}(\text{Sp}(R[1/p]), \mathbb{Z}/p^n\mathbb{Z})$, car l'affinoïde $\text{Spa}(R[1/p], R)$ est un espace $K(\pi, 1)$ pour les coefficients de torsion (voir [Scholze 2013, Theorem 4.9]). Quand le diviseur horizontal n'est pas trivial, le résultat a été prouvé par Colmez et Nizioł [2017, §5.1.4] dans le cas arithmétique. La preuve est identique pour le cas géométrique et on obtient

$$R\Gamma(G_R, \mathbb{Z}/p^n(r)) \cong R\Gamma_{\text{ét}}\left(\text{Sp}\left(R\left[\frac{1}{p}\right]\right) \setminus D_C, \mathbb{Z}/p^n\mathbb{Z}(r)\right).$$

3. Anneaux de périodes

Dans cette partie, R est un anneau comme à la section 2B2 et on suppose de plus que $\text{Spf}(R)$ est connexe. Pour la preuve du théorème 2.4, on a besoin de définir une notion d'anneaux de périodes ($\mathbb{A}_{\text{inf}}, \mathbb{A}_{\text{cris}}, \dots$) sur \bar{R} et R . Les suites exactes prouvées dans les sections suivantes joueront notamment un rôle important dans la suite.

3A. Définitions des anneaux. On reprend ici la construction des anneaux de périodes donnée dans [Colmez et Nizioł 2017, §2.4].

3A1. *Les anneaux $\mathbb{E}_{\bar{R}}, \mathbb{A}_{\bar{R}}$ et $\mathbb{A}_{\text{cris}}(\bar{R})$.* La complétion p -adique $\widehat{\bar{R}}$ de \bar{R} est une algèbre perfectoïde et on peut définir les anneaux

$$\mathbb{E}_{\bar{R}}^\pm := \varprojlim_{x \mapsto \varphi(x)} (\widehat{\bar{R}}/p), \quad \mathbb{A}_{\bar{R}}^\pm := W(\mathbb{E}_{\bar{R}}^\pm), \quad \mathbb{E}_{\bar{R}} = \mathbb{E}_{\bar{R}}^\pm \left[\frac{1}{[p^b]} \right], \quad \mathbb{A}_{\bar{R}} = W(\mathbb{E}_{\bar{R}}).$$

On rappelle qu'on a les éléments

$$\varepsilon = (1, \zeta_p, \zeta_{p^2}, \dots) \in \mathbb{E}_{\bar{R}}^+, \quad \mu = [\varepsilon] - 1 \in \mathbb{A}_{\bar{R}}^+, \quad \xi = \frac{\mu}{\varphi^{-1}(\mu)} \in \mathbb{A}_{\bar{R}}^+.$$

On définit $v_{\mathbb{E}} : \mathbb{E}_{\bar{R}} \rightarrow \mathbb{Q} \cup \{\infty\}$ par $v_{\mathbb{E}}(x_0, x_1, x_2, \dots) = v_p(x_0)$. On a (voir [Andreatta et Iovita 2008, §2.4]) :

- (1) $v_{\mathbb{E}}(x) = +\infty$ si et seulement si $x = 0$.
- (2) $v_{\mathbb{E}}(xy) \geq v_{\mathbb{E}}(x) + v_{\mathbb{E}}(y)$.
- (3) $v_{\mathbb{E}}(x + y) \geq \min(v_{\mathbb{E}}(x), v_{\mathbb{E}}(y))$ avec égalité si $v_{\mathbb{E}}(x) \neq v_{\mathbb{E}}(y)$.
- (4) $v_{\mathbb{E}}(\varphi(x)) = pv_{\mathbb{E}}(x)$.

On définit un morphisme surjectif

$$\theta : \mathbb{A}_{\bar{R}}^+ \rightarrow \widehat{\bar{R}}, \quad \sum_{k \in \mathbb{N}} p^k [x_k] \mapsto \sum_{k \in \mathbb{N}} p^k x_k^{(0)},$$

où $[\cdot] : \mathbb{E}_{\bar{R}} \rightarrow \mathbb{A}_{\bar{R}}$ est le morphisme de relèvement et $x_k = (x_k^{(0)}, \dots, x_k^{(n)}, \dots)$. On a de plus que le noyau de θ est principal et engendré par ξ (ou par $\xi_0 := p - [p^b]$).

On peut aussi munir $\mathbb{A}_{\bar{R}}$ de la topologie faible dont un système fondamental de voisinages de 0 est donné par les $U_{n,h} := p^n \mathbb{A}_{\bar{R}} + \mu^h \mathbb{A}_{\bar{R}}$.

On définit $\mathbb{A}_{\text{cris}}(\bar{R})$ comme la complétion p -adique de $\mathbb{A}_{\bar{R}}^+[\xi^k/k!, k \in \mathbb{N}]$ et on le munit de la filtration $F^r \mathbb{A}_{\text{cris}}(\bar{R})$ où $F^r \mathbb{A}_{\text{cris}}(\bar{R})$ est l'idéal de $\mathbb{A}_{\text{cris}}(\bar{R})$ engendré par les $\xi^k/k!$ pour $k \geq r$. Posons

$$t = \log(1 + \mu) \in \mathbb{A}_{\text{cris}}(\bar{R}).$$

On définit $\mathbb{B}_{\text{cris}}^+(\bar{R}) = \mathbb{A}_{\text{cris}}(\bar{R})[1/p]$ et $\mathbb{B}_{\text{cris}}(\bar{R}) = \mathbb{B}_{\text{cris}}^+(\bar{R})[1/t]$ et on les munit de la filtration induite de celle de \mathbb{A}_{cris} . Soient $\mathbb{B}_{\text{dR}}^+(\bar{R}) = \varprojlim_r \mathbb{B}_{\text{cris}}^+(\bar{R})/F^r \mathbb{B}_{\text{cris}}^+(\bar{R})$ et $\mathbb{B}_{\text{dR}}(\bar{R}) = \mathbb{B}_{\text{dR}}^+(\bar{R})[1/t]$. On munit ces anneaux de la filtration donnée par les puissances de ξ . On note ensuite $\mathbb{B}_{\text{st}}^+(\bar{R}) := \mathbb{B}_{\text{cris}}^+(\bar{R})[u]$ où u est une variable. On étend l'action du Frobenius φ en posant $\varphi(u) = pu$. On définit une application de monodromie $N : \mathbb{B}_{\text{st}}^+(\bar{R}) \rightarrow \mathbb{B}_{\text{st}}^+(\bar{R})$ par $N = -d/du$. On a un plongement $\mathbb{B}_{\text{st}}^+(\bar{R}) \hookrightarrow \mathbb{B}_{\text{dR}}^+(\bar{R})$ donné par $u \mapsto u_{\varpi} := \log([\varpi^b]/\varpi)$ et qui permet d'induire l'action de G_K à $\mathbb{B}_{\text{st}}^+(\bar{R})$. Enfin, on note $\mathbb{B}_{\text{st}}(\bar{R}) = \mathbb{B}_{\text{cris}}(\bar{R})[u_{\varpi}]$, l'anneau de périodes semi-stable.

3A2. Les anneaux $\mathbb{A}_{\bar{R}}^{(0,v]}$, $\mathbb{A}_{\bar{R}}^{[u]}$ et $\mathbb{A}_{\bar{R}}^{[u,v]}$. Pour $0 < u \leq v$, on définit les anneaux suivants :

- $\mathbb{A}_{\bar{R}}^{[u]}$, la complétion p -adique de $\mathbb{A}_{\bar{R}}^+[[\beta]/p]$ pour β un élément de $\mathbb{E}_{\bar{R}}^+$ avec $v_{\mathbb{E}}(\beta) = 1/u$.
- $\mathbb{A}_{\bar{R}}^{[u,v]}$, la complétion p -adique de $\mathbb{A}_{\bar{R}}^+[p/[\alpha], [\beta]/p]$ pour α et β des éléments de $\mathbb{E}_{\bar{R}}^+$ avec $v_{\mathbb{E}}(\alpha) = 1/v$ et $v_{\mathbb{E}}(\beta) = 1/u$.
- $\mathbb{A}_{\bar{R}}^{(0,v]}$:= $\{x = \sum_{n \in \mathbb{N}} [x_n] p^n \in \mathbb{A}_{\bar{R}} \mid x_n \in \mathbb{E}_{\bar{R}}, v_{\mathbb{E}}(x_n) + n/v \rightarrow +\infty \text{ quand } n \rightarrow \infty\}$.

On définit une application $w_v : \mathbb{A}_{\bar{R}}^{(0,v]}$ $\rightarrow \mathbb{R} \cup \{\infty\}$ par

$$w_v(x) = \begin{cases} \infty & \text{si } x = 0, \\ \inf_{n \in \mathbb{N}} (v v_{\mathbb{E}}(x_n) + n) & \text{sinon.} \end{cases}$$

On note ensuite $\mathbb{A}_{\bar{R}}^{(0,v]^+}$ l'ensemble des éléments x de $\mathbb{A}_{\bar{R}}^{(0,v]}$ tels que $w_v(x) \geq 0$. L'anneau $\mathbb{A}_{\bar{R}}^{(0,v]}$ est séparé et complet pour la topologie induite par w_v ; la preuve est identique à celle d'[Andreatta et Brinon 2008, proposition 4.2].

Si $v \geq 1 \geq u$, on a des injections

$$\mathbb{A}_{\bar{R}}^{[u]} \hookrightarrow \mathbb{B}_{\text{dR}}^+(\bar{R}), \quad \mathbb{A}_{\bar{R}}^{[u,v]} \hookrightarrow \mathbb{B}_{\text{dR}}^+(\bar{R}), \quad \mathbb{A}_{\bar{R}}^{(0,v]} \hookrightarrow \mathbb{B}_{\text{dR}}^+(\bar{R}),$$

ce qui nous permet de définir des filtrations sur ces trois anneaux.

On note $\mathbb{A}^{[u]}$, $\mathbb{A}^{[u,v]}$ et $\mathbb{A}^{(0,v]}$ les anneaux précédents obtenus pour $R = \mathcal{O}_C$.

Proposition 3.1. *Supposons $u \leq 1 \leq v$. L'idéal $p^r F^r \mathbb{A}^{[u,v]}$ est inclus dans $\xi^r \mathbb{A}^{[u,v]} = \xi_0^r \mathbb{A}^{[u,v]}$ où $\xi_0 := p - [p^b]$.*

Démonstration. On rappelle d'abord (voir [Tsuji 1999, Lemma A2.13]) qu'on a

$$\mathbb{A}_{\text{inf}} \cap (\xi^r \mathbb{B}_{\text{dR}}^+) = \xi^r \mathbb{A}_{\text{inf}} = \xi_0^r \mathbb{A}_{\text{inf}}. \quad (13)$$

Soit maintenant x dans $F^r \mathbb{A}^{[u,v]} = (\xi^r \mathbb{B}_{\text{dR}}^+) \cap \mathbb{A}^{[u,v]}$. Par définition de $\mathbb{A}^{[u,v]}$, on peut écrire

$$x = \sum_{n \geq 0} a_n \frac{p^n}{[\alpha^n]} + \sum_{n \geq 0} b_n \frac{[\beta^n]}{p^n}$$

avec $v_{\mathbb{E}}(\alpha) = \frac{1}{v}$ et $v_{\mathbb{E}}(\beta) = \frac{1}{u}$ et (a_n) et (b_n) des suites de \mathbb{A}_{inf} qui tendent vers 0. Pour simplifier, on note

$$A := \sum_{n \geq 0} a_n \frac{p^n}{[\alpha^n]} \quad \text{et} \quad B := \sum_{n \geq 0} b_n \frac{[\beta^n]}{p^n}.$$

On montre d'abord que $p^r A$ est dans $\mathbb{A}_{\text{inf}} + \xi^r \mathbb{A}^{[u,v]}$. On a $\frac{p}{[\alpha]} = \frac{1}{1 + \frac{\xi_0}{p}} [\alpha']$ avec $v_{\mathbb{E}}(\alpha') = 1 - \frac{1}{v} \geq 0$. D'où, dans \mathbb{B}_{dR}^+ ,

$$p^r \frac{p}{[\alpha]} = p^r \cdot \left(\sum_{n \geq 0} (-1)^n \frac{\xi_0^n}{p^n} \right) \cdot [\alpha'] = \left(\sum_{0 \leq n < r} (-1)^n \xi_0^n p^{r-n} \right) \cdot [\alpha'] + \xi_0^r \cdot \left(\sum_{n \geq 0} (-1)^{n+r} \frac{\xi_0^n}{p^n} \right) \cdot [\alpha'],$$

c'est-à-dire

$$p^r \frac{p}{[\alpha]} = a + \xi_0^r \frac{(-1)^r}{1 + \frac{\xi_0}{p}} [\alpha'] = a + \xi_0^r \cdot (-1)^r \cdot \frac{p}{[\alpha]} \quad \text{avec } a \in \mathbb{A}_{\text{inf}}.$$

On en déduit le résultat.

Montrons ensuite que $p^r B$ est dans $\xi^r \mathbb{A}^{[u,v]}$. Comme pour le point précédent, on a $\frac{[\beta]}{p} = (1 + \frac{\xi_0}{p}) [\beta']$ avec $v_{\mathbb{E}}(\beta') = \frac{1}{u} - 1 \geq 0$. On peut alors écrire

$$B = \sum_{n \geq 0} b'_n \frac{[\beta']^n}{p^n} \frac{\xi_0^n}{p^n} \quad \text{avec } b'_n \in \mathbb{A}_{\text{inf}},$$

et on peut supposer que ξ_0 ne divise pas b'_n dans \mathbb{A}_{inf} .

Mais \mathbb{B}_{dR}^+ est un anneau de valuation discrète dont l'idéal maximal est donné par ξ : on note v_ξ sa valuation. Par hypothèse, on a $v_\xi(B) \geq r$. De plus, en utilisant (13), on voit que

$$v_\xi\left(b'_n[(\beta')^n] \frac{\xi_0^n}{p^n}\right) = n,$$

et donc $b'_n = 0$ pour tout $n < r$. On a alors

$$p^r B = p^r \cdot \left(\sum_{n \geq r} b'_n[(\beta')^n] \frac{\xi_0^n}{p^n}\right) = \xi_0^r \cdot \left(\sum_{n \geq 0} b'_{n+r}[(\beta')^{n+r}] \frac{\xi_0^n}{p^n}\right) \in \xi^r \mathbb{A}^{[u,v]}.$$

On obtient que $p^r x = p^r A + p^r B$ est dans $\mathbb{A}_{\text{inf}} + \xi^r \mathbb{A}^{[u,v]}$, écrivons-le $x_0 + \xi^r \tilde{x}$ avec $x_0 \in \mathbb{A}_{\text{inf}}$ et $\tilde{x} \in \mathbb{A}^{[u,v]}$. On a $x_0 = p^r x - \xi^r \tilde{x}$ est dans $\xi^r \mathbb{B}_{\text{dR}}^+$ et comme x_0 est aussi dans \mathbb{A}_{inf} , via (13), on obtient que x_0 est dans $\xi^r \mathbb{A}_{\text{inf}}$.

Finalement, on obtient que $p^r x$ est dans $\xi^r \mathbb{A}^{[u,v]}$ et donc $p^r F^r \mathbb{A}^{[u,v]} \subseteq \xi^r \mathbb{A}^{[u,v]}$. □

On utilisera plus loin le résultat suivant :

Proposition 3.2 [Colmez et Nizioł 2017, §2.4.2]. *On a les inclusions suivantes :*

(1) $\mathbb{A}_{\text{cris}}(\bar{R}) \subseteq \mathbb{A}_{\bar{R}}^{[u]}$ si $u \geq \frac{1}{p-1}$.

(2) $\mathbb{A}_{\text{cris}}(\bar{R}) \supseteq \mathbb{A}_{\bar{R}}^{[u]}$ si $u \leq \frac{1}{p}$.

3B. Suites exactes fondamentales. On rappelle ici les différentes suites exactes fondamentales vérifiées par les anneaux de périodes définis précédemment.

3B1. *Suites exactes pour les anneaux $\mathbb{A}_{\bar{R}}$ et $\mathbb{A}_{\bar{R}}^{(0,v)+}$.*

Théorème 3.3 [Andreata et Iovita 2008, Proposition B.1]. *On a les suites exactes*

$$0 \rightarrow \mathbb{Z}_p \rightarrow \mathbb{A}_{\bar{R}} \xrightarrow{1-\varphi} \mathbb{A}_{\bar{R}} \rightarrow 0, \tag{14}$$

$$0 \rightarrow \mathbb{Z}_p \rightarrow \mathbb{A}_{\bar{R}}^{(0,v)+} \xrightarrow{1-\varphi} \mathbb{A}_{\bar{R}}^{(0,v/p)+} \rightarrow 0. \tag{15}$$

Remarque 3.4. De la même façon on a une suite exacte $0 \rightarrow \mathbb{Z}_p \rightarrow \mathbb{A}_{\bar{R}}^+ \xrightarrow{1-\varphi} \mathbb{A}_{\bar{R}}^+ \rightarrow 0$.

3B2. *Suite exacte pour l'anneau \mathbb{A}_{cris} .* Pour r dans \mathbb{N} , on écrit $r = a(r)(p-1) + b(r)$ avec $0 \leq b(r) \leq p-2$ et on note $t^{\{r\}} := t^r / (a(r)! p^{a(r)})$. Alors, comme on a

$$\frac{t^r}{a(r)! p^{a(r)}} = t^{b(r)} \left(\frac{t^{p-1}}{p}\right)^{[a(r)]}$$

et que t^{p-1}/p est dans $\mathbb{A}_{\text{cris}}(\bar{R})$, on obtient que $t^{\{r\}}$ est dans $\mathbb{A}_{\text{cris}}(\bar{R})$.

Théorème 3.5 [Tsuji 1999, Theorem A3.26]. *Pour tout $r \geq 0$, on a la suite exacte*

$$0 \rightarrow \mathbb{Z}_p t^{\{r\}} \rightarrow F^r \mathbb{A}_{\text{cris}}(\bar{R}) \xrightarrow{1-\varphi/p^r} \mathbb{A}_{\text{cris}}(\bar{R}) \rightarrow 0. \tag{16}$$

3B3. *Suites exactes pour les anneaux $\mathbb{A}_{\bar{R}}^{[u,v]}$ et $\mathbb{A}_{\bar{R}}^{[u]}$.* Colmez et Nizioł [2017] ont montré que des résultats similaires sont vérifiés par les anneaux $\mathbb{A}_{\bar{R}}^{[u,v]}$ et $\mathbb{A}_{\bar{R}}^{[u]}$.

Théorème 3.6 [Colmez et Nizioł 2017, Lemma 2.23]. *Soit u tel que $\frac{p-1}{p} \leq u \leq 1$.*

(1) *On a une suite p^{2r} -exacte si $p > 2$ (ou p^{3r} -exacte si $p = 2$)*

$$0 \rightarrow \mathbb{Z}_p(r) \rightarrow (\mathbb{A}_{\bar{R}}^{[u]})^{\varphi=p^r} \rightarrow \mathbb{A}_{\bar{R}}^{[u]}/F^r \rightarrow 0. \quad (17)$$

(2) *On a une suite p^{2r} -exacte*

$$0 \rightarrow (\mathbb{A}_{\bar{R}}^{[u]})^{\varphi=p^r} \rightarrow \mathbb{A}_{\bar{R}}^{[u]} \xrightarrow{p^r-\varphi} \mathbb{A}_{\bar{R}}^{[u]} \rightarrow 0. \quad (18)$$

(3) *On a une suite p^{4r} -exacte si $p > 2$ (ou p^{5r} -exacte si $p = 2$)*

$$0 \rightarrow \mathbb{Z}_p(r) \rightarrow F^r \mathbb{A}_{\bar{R}}^{[u]} \xrightarrow{p^r-\varphi} \mathbb{A}_{\bar{R}}^{[u]} \rightarrow 0. \quad (19)$$

Théorème 3.7 [Colmez et Nizioł 2017, Lemma 2.23]. *Soient u et v tels que $\frac{p-1}{p} \leq u \leq 1 \leq v$.*

(1) *On a une suite p^{3r} -exacte si $p > 2$ (ou p^{4r} -exacte si $p = 2$)*

$$0 \rightarrow \mathbb{Z}_p(r) \rightarrow (\mathbb{A}_{\bar{R}}^{[u,v]})^{\varphi=p^r} \rightarrow \mathbb{A}_{\bar{R}}^{[u,v]}/F^r \rightarrow 0. \quad (20)$$

(2) *On a une suite p^{2r} -exacte*

$$0 \rightarrow (\mathbb{A}_{\bar{R}}^{[u,v]})^{\varphi=p^r} \rightarrow \mathbb{A}_{\bar{R}}^{[u,v]} \xrightarrow{p^r-\varphi} \mathbb{A}_{\bar{R}}^{[u,v/p]} \rightarrow 0. \quad (21)$$

(3) *On a une suite p^{5r} -exacte si $p > 2$ (ou p^{6r} -exacte si $p = 2$)*

$$0 \rightarrow \mathbb{Z}_p(r) \rightarrow F^r \mathbb{A}_{\bar{R}}^{[u,v]} \xrightarrow{p^r-\varphi} \mathbb{A}_{\bar{R}}^{[u,v/p]} \rightarrow 0. \quad (22)$$

3C. Anneaux de convergence et morphisme de Frobenius. On considère les anneaux

$$R^{[u]} := \mathbb{A}^{[u]} \widehat{\otimes}_{\mathbb{A}_{\text{inf}}} R_{\text{inf}}^+, \quad R^{[u,v]} := \mathbb{A}^{[u,v]} \widehat{\otimes}_{\mathbb{A}_{\text{inf}}} R_{\text{inf}}^+, \quad R^{(0,v)^+} := \mathbb{A}^{(0,v)^+} \widehat{\otimes}_{\mathbb{A}_{\text{inf}}} R_{\text{inf}}^+$$

où les produits tensoriels sont complétés pour la topologie (p, ξ) -adique. On définit les filtrations

$$R^{[u]} := F^r \mathbb{A}^{[u]} \widehat{\otimes}_{\mathbb{A}_{\text{inf}}} R_{\text{inf}}^+, \quad R^{[u,v]} := F^r \mathbb{A}^{[u,v]} \widehat{\otimes}_{\mathbb{A}_{\text{inf}}} R_{\text{inf}}^+, \quad R^{(0,v)^+} := F^r \mathbb{A}^{(0,v)^+} \widehat{\otimes}_{\mathbb{A}_{\text{inf}}} R_{\text{inf}}^+.$$

On rappelle qu'on avait

$$R_{\text{cris}, \square}^+ := \mathbb{A}_{\text{cris}} \left\{ X, \frac{1}{X_1 \cdots X_a}, \frac{[\varpi^b]}{X_{a+1} \cdots X_{a+b}} \right\} \quad \text{et} \quad R_{\text{cris}}^+ := \mathbb{A}_{\text{cris}} \widehat{\otimes}_{\mathbb{A}_{\text{inf}}} R_{\text{inf}}^+$$

et que R_{inf} et R_{cris} sont les compléments p -adiques de $R_{\text{inf}}^+[1/[\varpi^b]]$ et $R_{\text{cris}}^+[1/[\varpi^b]]$.

Si φ est le Frobenius sur \mathbb{A}_{inf} , on étend φ à $R_{\text{inf}, \square}^+$ en posant $\varphi(X_i) = X_i^p$ pour i dans $\{1, \dots, d\}$. On utilise ensuite la proposition 2.2 pour l'étendre à R_{inf}^+ (prendre $\Lambda_1 = R_{\text{inf}, \square}^+$, $\Lambda_2 = \Lambda_1' = R_{\text{inf}}^+$, $Z_\varphi = Z^p$ et $I = (p)$).

On définit φ sur $\mathbb{A}^{[u]}$, $\mathbb{A}^{[u,v]}$ et $\mathbb{A}^{(0,v)+}$ par

$$\varphi\left(\frac{p}{[\alpha]}\right) = \frac{p}{[\alpha^p]}, \quad \varphi\left(\frac{[\beta]}{p}\right) = \frac{[\beta^p]}{p}, \quad \varphi\left(\sum_{n \in \mathbb{N}} [x_n] p^n\right) = \sum_{n \in \mathbb{N}} [x_n^p] p^n$$

et on étend φ à $R^{[u]}$, $R^{[u,v]}$, $R^{(0,v)+}$ et R_{cris}^+ . On a alors

$$\varphi(R^{[u]}) = R^{[u/p]}, \quad \varphi(R^{[u,v]}) = R^{[u/p, v/p]}, \quad \varphi(R^{(0,v)+}) = R^{(0, v/p)+}.$$

On note ψ l'inverse de φ sur \mathbb{A}_{inf} . On va étendre ψ aux anneaux R_{inf}^+ , R_{cris}^+ , R_{cris}^+ , $R^{[u]}$, $R^{[u,v]}$ et $R^{(0,v)+}$.

Pour $\alpha = (\alpha_1, \dots, \alpha_d)$ avec α_i dans $\{0, \dots, p-1\}$, on note

$$u_\alpha = X_1^{\alpha_1} \dots X_d^{\alpha_d}$$

et pour j dans $\{1, \dots, d\}$,

$$\partial_j = X_j \frac{\partial}{\partial X_j}.$$

La même preuve que [Colmez et Nizioł 2017, §2.2.7] donne le lemme et le corollaire suivants :

Lemme 3.8 [Colmez et Nizioł 2017, Lemma 2.7]. *Tout élément x de R_{inf}/p s'écrit de manière unique sous la forme $\sum_{\alpha} c_{\alpha}(x)$ avec $c_{\alpha}(x) = x_{\alpha}^p u_{\alpha}$ pour un x_{α} dans R_{inf}/p .*

De plus, si x est dans R_{inf}^+/p alors $c_{\alpha}(x)$ et x_0 sont dans R_{inf}^+/p .

Corollaire 3.9 [Colmez et Nizioł 2017, Corollary 2.8]. *Tout élément x de R_{inf} s'écrit de manière unique sous la forme $\sum_{\alpha} c_{\alpha}(x)$ avec $c_{\alpha}(x) = \varphi(x_{\alpha}) u_{\alpha}$ pour un x_{α} dans R_{inf} .*

De plus, si x est dans R_{inf}^+ alors x_0 est dans R_{inf}^+ et $\partial_j c_{\alpha}(x) - \alpha_j c_{\alpha}(x) \in pR_{\text{inf}}^+$.

On définit alors ψ sur R_{inf}^+ par $\psi(x) = \varphi^{-1}(c_0(x))$. L'application ψ n'est pas un morphisme d'anneaux, mais on a $\psi \circ \varphi(x) = x$ et plus généralement, $\psi(\varphi(x)y) = x\psi(y)$ pour x et y dans R_{inf}^+ .

On étend ensuite ψ à R_{inf} , R_{cris}^+ , R_{cris}^+ , $R^{[u]}$, $R^{[u,v]}$ et $R^{(0,v)+}$ et on obtient des applications surjectives

$$\psi : R^{[u]} \rightarrow R^{[pu]}, \quad R^{[u,v]} \rightarrow R^{[pu, pv]}, \quad R^{(0,v)+} \rightarrow R^{(0, pv)+}.$$

Remarque 3.10. Comme dans [Colmez et Nizioł 2017], on peut voir que les applications $x \mapsto c_{\alpha}(x)$ donnent des décompositions

$$S = \bigoplus_{\alpha} S_{\alpha} \quad \text{et} \quad S^{\psi=0} = \bigoplus_{\alpha \neq 0} S_{\alpha}$$

pour $S \in \{R_{\text{inf}}, R_{\text{inf}}^+, R_{\text{cris}}, R_{\text{cris}}^+, R^{[u]}, R^{[u,v]}, R^{(0,v)+}\}$. On a de plus $\partial_j = \alpha_j$ sur S_{α}/pS_{α} .

4. Passage de R_{cris}^+ à $R^{[u,v]}$

Soit R comme dans la section précédente. La première étape dans la preuve du [théorème 2.4](#) est de construire un quasi-isomorphisme entre le complexe $\text{Syn}(R_{\text{cris}}^+, r)$ et un complexe $C(R^{[u,v]}, r)$ défini à partir de l'anneau $R^{[u,v]}$.

Dans cette partie, on suppose $u \geq 1/(p-1)$ de telle sorte que $\mathbb{A}_{\text{cris}} \subseteq \mathbb{A}^{[u]} \subseteq \mathbb{A}^{[u,v]}$. Si $S = R^{[u]}$ (respectivement $R^{[u,v]}$), on écrit $S' = R^{[u]}$ (respectivement $R^{[u,v/p]}$) et $S'' = R^{[pu]}$ (respectivement $R^{[pu,v]}$) et on note Ω_S^\bullet le complexe des log-différentielles de S sur $\mathbb{A}^{[u]}$ (respectivement $\mathbb{A}^{[u,v]}$). Pour i dans $\{1, \dots, d\}$, on note $J_i = \{(j_1, \dots, j_i) \mid 1 \leq j_1 \leq \dots \leq j_i \leq d\}$ et $\omega_i = dX_i/X_i$. Si \mathbf{j} est dans J_i , on écrit $\omega_{\mathbf{j}} = \omega_{j_1} \wedge \dots \wedge \omega_{j_i}$. La filtration $F^r \Omega_S^i$ est le sous- S -module de Ω_S^i engendré par $F^r S \cdot \Omega_S^i$, soit

$$F^r \Omega_S^i = \bigoplus_{\mathbf{j} \in J_i} F^r S \cdot \omega_{\mathbf{j}}.$$

On étend φ à Ω_S^i par

$$\varphi \left(\sum_{\mathbf{j} \in J_i} f_{\mathbf{j}} \omega_{\mathbf{j}} \right) = \sum_{\mathbf{j} \in J_i} \varphi(f_{\mathbf{j}}) \omega_{\mathbf{j}}.$$

On définit ensuite le complexe $C(S, r) := [F^r \Omega_S^\bullet \xrightarrow{p^r - p^r \varphi} \Omega_{S'}^\bullet]$. Enfin, on étend ψ à Ω_S^i en posant $\psi \left(\sum_{\mathbf{j} \in J_i} f_{\mathbf{j}} \omega_{\mathbf{j}} \right) = \sum_{\mathbf{j} \in J_i} \psi(f_{\mathbf{j}}) \omega_{\mathbf{j}}$ et on note $C^\psi(S, r) := [F^r \Omega_S^\bullet \xrightarrow{p^r \psi - p^r} \Omega_{S''}^\bullet]$.

Le p^{10r} -quasi-isomorphisme $\tau_{\leq r} C(R_{\text{cris}}^+, r) \rightarrow \tau_{\leq r} C(R^{[u,v]}, r)$ (voir (23) ci-dessous) s'obtient de manière similaire à son analogue arithmétique [Colmez et Nizioł 2017, Section 3.2]. Les principales différences viennent du fait qu'on ne dispose pas de la variable arithmétique X_0 qui permet de donner une interprétation des anneaux considérés en termes de séries de Laurent (sur l'anneau $W(k)$) ou de définir ψ de telle sorte à ce qu'il soit « suffisamment » topologiquement nilpotent. La démonstration se fait en trois parties. On montre dans un premier temps qu'on a un p^{8r} -quasi-isomorphisme $\text{Syn}(R_{\text{cris}}^+, r) \xrightarrow{\sim} C(R^{[u]}, r)$. Contrairement au cas arithmétique, si f est un élément de $R^{[u]}$, on n'a pas, a priori, une décomposition $f = f_1 + f_2$ avec f_1 dans $F^r R^{[u]}$ et f_2 tel que $p^r f_2$ est dans R_{inf}^+ (voir [Colmez et Nizioł 2017, Remark 2.6]) : au lieu de cela, on utilise ici la p^{2r} -exactitude de la suite (17) (voir lemme 4.2). L'étape suivante consiste à passer du complexe $C(R^{[u]}, r)$ au complexe $C^\psi(R^{[u]}, r)$. Enfin, on montre que l'inclusion $R^{[u]} \hookrightarrow R^{[u,v]}$ induit un p^{2r} -quasi-isomorphisme sur les complexes tronqués $\tau_{\leq r} C^\psi(S, r)$. La preuve diffère ici de celle de [Colmez et Nizioł 2017] dans la mesure où la série $\sum_{n \geq 1} \psi^n(x)$ pour x dans $R^{[u,v]}/R^{[u]}$ ne converge pas nécessairement pour notre définition de ψ . Il reste vrai, cependant, $\psi - 1$ est surjective sur $\mathbb{A}^{(0,v]^+}$, ce qui permet de conclure (voir lemme 4.7).

4A. Disque de convergence. On commence par montrer qu'il existe un p^{10r} -quasi-isomorphisme $\text{Syn}(R_{\text{cris}}^+, r) \xrightarrow{\sim} C(R^{[u]}, r)$. La preuve du lemme suivant est identique à celle du cas arithmétique.

Lemme 4.1 [Colmez et Nizioł 2017, Lemma 3.1]. *Soit f dans $R^{[u]}$ tel que $f = \sum_{n \geq N} x_n [\beta]^n / p^n$ pour un N dans \mathbb{N} et soit s dans \mathbb{Z} . Si $N \geq s/(p-1)$, alors il existe g dans $R^{[u]}$ tel que $f = (1 - p^{-s} \varphi)(g)$.*

Comme dans [Colmez et Nizioł 2017, Lemma 3.2], on utilise le lemme ci-dessus pour montrer les isomorphismes suivants :

Lemme 4.2. *Soient r dans \mathbb{N} et u et u' des réels tels que $1/(p-1) \leq u \leq 1$ et $u' \leq u \leq pu'$. Alors :*

- (1) *L'application $p^r - p^i \varphi$ induit un p^{5r} -isomorphisme $F^r \Omega_{R^{[u]}}^i / F^r \Omega_{R_{\text{cris}}^+}^i \xrightarrow{\sim} \Omega_{R^{[u]}}^i / \Omega_{R_{\text{cris}}^+}^i$.*
- (2) *L'application $p^r - p^i \varphi$ induit un p^{5r} -isomorphisme $F^r \Omega_{R^{[u]}}^i / F^r \Omega_{R^{[u']}}^i \xrightarrow{\sim} \Omega_{R^{[u]}}^i / \Omega_{R^{[u']}}^i$.*

Démonstration. Comme on a $\varphi(\omega_j) = \omega_j$ pour j dans J_i , il suffit de montrer que $p^r - p^i \varphi$ induit un p^{4r} -isomorphisme $F^r R^{[u]} / F^r R_{\text{cris}}^+ \xrightarrow{\sim} R^{[u]} / R_{\text{cris}}^+$ (respectivement $F^r R^{[u]} / F^r R^{[u']} \xrightarrow{\sim} R^{[u]} / R^{[u']}$). On note $A = R^{[u']}$ ou R_{cris}^+ et $B = R^{[u]}$.

On montre d'abord la p^r -injectivité. Soit f dans $F^r B$ tel que $(p^r - p^i \varphi)(f)$ est dans A . Il suffit de voir que $p^r f$ est dans A : c'est bien le cas, car $p^r f = (p^r - p^i \varphi)(f) + p^i \varphi(f)$ et $\varphi(B) \subseteq A$.

Il reste à voir que l'application est p^{5r} -surjective. Soit f dans B . On peut écrire $f = f_1 + f_2$ avec

$$f_1 = \sum_{n < N} x_n \frac{[\beta]^n}{p^n} \quad \text{et} \quad f_2 = \sum_{n \geq N} x_n \frac{[\beta]^n}{p^n}$$

où $N = \lfloor (r - i) / (p - 1) \rfloor$ et $x_n \in R_{\text{inf}}^+$ tend vers 0 à l'infini. On a alors que $p^r f_1$ est dans A . Par le lemme précédent, il existe g dans B tel que $f_2 = (1 - p^{i-r} \varphi)(g)$. En utilisant la suite p^{3r} -exacte (17), c'est-à-dire

$$0 \rightarrow \mathbb{Z}_p(r) \rightarrow (\mathbb{A}^{[u]})^{\varphi=p^r} \rightarrow \mathbb{A}^{[u]} / F^r \rightarrow 0,$$

on remarque que pour tout élément y de $\mathbb{A}^{[u]}$ on a $p^{3r} y = y_1 + y_2$ avec y_1 dans $(\mathbb{A}^{[u]})^{\varphi=p^r}$ et y_2 dans $F^r \mathbb{A}^{[u]}$. Mais on a un p^r -isomorphisme

$$(\mathbb{A}_{\text{cris}})^{\varphi=p^r} \xrightarrow{\sim} (\mathbb{A}^{[u]})^{\varphi=p^r},$$

et donc $p^r y_1$ est dans \mathbb{A}_{cris} (respectivement dans $\mathbb{A}^{[u']}$).

Comme $R^{[u]} = \mathbb{A}^{[u]} \hat{\otimes}_{\mathbb{A}_{\text{inf}}} R_{\text{inf}}^+$, on peut donc écrire $p^{3r} g = g_1 + g_2$ avec $p^r g_1$ dans A et g_2 dans $F^r B$. On obtient

$$p^{5r} f = p^{5r} f_1 + (p^r - p^i \varphi)(p^r g_1 + p^r g_2),$$

et donc, modulo A , on a $p^{4r} f = (p^r - p^i \varphi)(p^r g_2)$, ce qui termine la démonstration. □

Corollaire 4.3. *Pour u et u' comme précédemment, on a :*

- (1) *L'injection $R_{\text{cris}}^+ \subseteq R^{[u]}$ induit un p^{10r} -quasi-isomorphisme $C(R_{\text{cris}}^+, r) \xrightarrow{\sim} C(R^{[u]}, r)$.*
- (2) *L'injection $R^{[u']} \subseteq R^{[u]}$ induit un p^{10r} -quasi-isomorphisme $C(R^{[u']}, r) \xrightarrow{\sim} C(R^{[u]}, r)$.*

4B. Passage de φ à ψ . On rappelle qu'on a $C^\psi(R^{[u]}, r) := [F^r \Omega_{R^{[u]}}^{\bullet} \xrightarrow{p^r \psi - p^\bullet} \Omega_{R^{[u]}}^{\bullet}]$.

Lemme 4.4 [Colmez et Niziol 2017, Lemma 3.4]. *On a un quasi-isomorphisme $C(R^{[u]}, r) \xrightarrow{\sim} C^\psi(R^{[u]}, r)$ donné par le diagramme commutatif*

$$\begin{array}{ccc} F^r \Omega_{R^{[u]}}^{\bullet} & \xrightarrow{p^r - p^\bullet \varphi} & \Omega_{R^{[u]}}^{\bullet} \\ \downarrow \text{Id} & & \downarrow \psi \\ F^r \Omega_{R^{[u]}}^{\bullet} & \xrightarrow{p^r \psi - p^\bullet} & \Omega_{R^{[u]}}^{\bullet} \end{array}$$

Remarque 4.5. La preuve du lemme est identique à celle donnée dans [Colmez et Nizioł 2017]. On montre de la même façon que le diagramme commutatif

$$\begin{CD} F^r \Omega_{R^{[u,v]}}^\bullet @>{p^r - p^\bullet \varphi}>> \Omega_{R^{[u,v/p]}}^\bullet \\ @V{\text{Id}}VV @VV{\psi}V \\ F^r \Omega_{R^{[u,v]}}^\bullet @>{p^r \psi - p^\bullet}>> \Omega_{R^{[pv,v]}}^\bullet \end{CD}$$

induit un quasi-isomorphisme $C(R^{[u,v]}, r) \xrightarrow{\sim} C^\psi(R^{[u,v]}, r)$.

4C. Anneaux de convergence. On passe maintenant de l’anneau $R^{[u]}$ à $R^{[u,v]}$.

Lemme 4.6. Soient u et v tels que $1/(p-1) \leq u \leq 1 \leq v$. Alors on a un p^r -isomorphisme

$$F^r R^{[u,v]} / F^r R^{[u]} \xrightarrow{\sim} R^{[u,v]} / R^{[u]}.$$

Démonstration. Comme on a, pour tout $n \geq 1$,

$$\{x \in \mathbb{A}^{[u,v]} / \mathbb{A}^{[u]} \mid p^n x = 0\} = \{x \in \mathbb{A}^{(0,v)+} / \mathbb{A}_{\text{inf}} \mid p^n x = 0\} = 0,$$

on obtient une suite exacte

$$0 \rightarrow \mathbb{A}^{[u]} / p^n \rightarrow \mathbb{A}^{[u,v]} / p^n \rightarrow (\mathbb{A}^{[u,v]} / \mathbb{A}^{[u]}) / p^n \rightarrow 0.$$

Pour tout $m \geq 1$, on a de plus que R_{inf}^+ / p^m est plat sur $\mathbb{A}_{\text{inf}} / p^m$ et donc la suite

$$0 \rightarrow \mathbb{A}^{[u]} / p^n \otimes_{\mathbb{A}_{\text{inf}} / p^m} R_{\text{inf}}^+ / p^m \rightarrow \mathbb{A}^{[u,v]} / p^n \otimes_{\mathbb{A}_{\text{inf}} / p^m} R_{\text{inf}}^+ / p^m \rightarrow (\mathbb{A}^{[u,v]} / \mathbb{A}^{[u]}) / p^n \otimes_{\mathbb{A}_{\text{inf}} / p^m} R_{\text{inf}}^+ / p^m \rightarrow 0$$

est exacte (on peut supposer $m \geq n$). On obtient finalement que, pour tout n et m , la suite

$$0 \rightarrow \mathbb{A}^{[u]} / p^n \otimes_{\mathbb{A}_{\text{inf}}} R_{\text{inf}}^+ / p^m \rightarrow \mathbb{A}^{[u,v]} / p^n \otimes_{\mathbb{A}_{\text{inf}}} R_{\text{inf}}^+ / p^m \rightarrow (\mathbb{A}^{[u,v]} / \mathbb{A}^{[u]}) / p^n \otimes_{\mathbb{A}_{\text{inf}}} R_{\text{inf}}^+ / p^m \rightarrow 0$$

est exacte. En prenant la limite sur (n, m) et en utilisant que les systèmes projectifs vérifient la condition de Mittag-Leffler, on obtient une suite exacte

$$0 \rightarrow R^{[u]} \rightarrow R^{[u,v]} \rightarrow \mathbb{A}^{[u,v]} / \mathbb{A}^{[u]} \widehat{\otimes}_{\mathbb{A}_{\text{inf}}} R_{\text{inf}}^+ \rightarrow 0.$$

Comme $F^r R^? = F^r \mathbb{A}^? \widehat{\otimes}_{\mathbb{A}_{\text{inf}}} R_{\text{inf}}^+$ pour $? \in \{[u], [u, v]\}$, le même raisonnement donne une suite exacte

$$0 \rightarrow F^r R^{[u]} \rightarrow F^r R^{[u,v]} \rightarrow F^r \mathbb{A}^{[u,v]} / F^r \mathbb{A}^{[u]} \widehat{\otimes}_{\mathbb{A}_{\text{inf}}} R_{\text{inf}}^+ \rightarrow 0.$$

On obtient

$$F^r R^{[u,v]} / F^r R^{[u]} \cong F^r \mathbb{A}^{[u,v]} / F^r \mathbb{A}^{[u]} \widehat{\otimes}_{\mathbb{A}_{\text{inf}}} R_{\text{inf}}^+ \quad \text{et} \quad R^{[u,v]} / R^{[u]} \cong \mathbb{A}^{[u,v]} / \mathbb{A}^{[u]} \widehat{\otimes}_{\mathbb{A}_{\text{inf}}} R_{\text{inf}}^+$$

et il suffit de montrer le résultat pour $R = \mathcal{O}_C$.

Comme $\mathbb{A}^{[u,v]}$ est la complétion de $\mathbb{A}_{\text{inf}}[p/[\alpha], [\beta]/p]$ et $\mathbb{A}^{[u]}$ est celle de $\mathbb{A}_{\text{inf}}[[\beta]/p]$, il suffit de montrer que $p^r(p/[\alpha])$ est dans l'image : c'est le cas (voir la preuve de la [proposition 3.1](#)) puisqu'on a

$$\frac{p}{[\alpha]} = \left(1 + \frac{[p^\flat] - p}{p}\right)^{-1} [\alpha'] \quad \text{avec } v_p(\alpha') = 1 - \frac{1}{v}. \quad \square$$

On peut maintenant montrer la version géométrique du lemme 3.6 de [\[Colmez et Nizioł 2017\]](#).

Lemme 4.7. *L'inclusion $R^{[u]} \hookrightarrow R^{[u,v]}$ induit un p^{2r} -quasi-isomorphisme*

$$\tau_{\leq r} C^\psi(R^{[u]}, r) \xrightarrow{\sim} \tau_{\leq r} C^\psi(R^{[u,v]}, r).$$

Démonstration. L'application est induite par

$$\begin{array}{ccc} F^r \Omega_{R^{[u]}}^\bullet & \xrightarrow{p^r \psi - p^\bullet} & \Omega_{R^{[pu]}}^\bullet \\ \downarrow & & \downarrow \\ F^r \Omega_{R^{[u,v]}}^\bullet & \xrightarrow{p^r \psi - p^\bullet} & \Omega_{R^{[pu,v]}}^\bullet \end{array}$$

Pour montrer qu'on a un p^{2r} -quasi-isomorphisme $\tau_{\leq r} C^\psi(R^{[u]}, r) \xrightarrow{\sim} \tau_{\leq r} C^\psi(R^{[u,v]}, r)$, il suffit de voir qu'on a un p^{2r} -quasi-isomorphisme

$$\tau_{\leq r} (F^r \Omega_{R^{[u,v]}}^\bullet / F^r \Omega_{R^{[u]}}^\bullet) \xrightarrow{p^r \psi - p^\bullet} \tau_{\leq r} (\Omega_{R^{[pu,v]}}^\bullet / \Omega_{R^{[pu]}}^\bullet).$$

On va prouver :

- (1) Pour tout $i \leq r$, $F^r \Omega_{R^{[u,v]}}^i / F^r \Omega_{R^{[u]}}^i \xrightarrow{p^r \psi - p^i} \Omega_{R^{[pu,v]}}^i / \Omega_{R^{[pu]}}^i$ est un p^{2r} -isomorphisme.
- (2) Pour $i = r + 1$, le morphisme $p^r \psi - p^{r+1} : F^r \Omega_{R^{[u,v]}}^{r+1} / F^r \Omega_{R^{[u]}}^{r+1} \rightarrow \Omega_{R^{[pu,v]}}^{r+1} / \Omega_{R^{[pu]}}^{r+1}$ est p^{2r} -injectif.

Prouvons le point (1). Soit $i \leq r$. Comme on a $\psi(\sum_{j \in J_i} f_j \omega_j) = \sum_{j \in J_i} \psi(f_j) \omega_j$, on se ramène à prouver que $p^r \psi - p^i : F^r R^{[u,v]} / F^r R^{[u]} \rightarrow R^{[pu,v]} / R^{[pu]}$ est un p^r -isomorphisme. Par le lemme précédent, il suffit de montrer que $p^r \psi - p^i : R^{[u,v]} / R^{[u]} \rightarrow R^{[pu,v]} / R^{[pu]}$ est un p^r -isomorphisme.

Pour $i < r$, $p^s \psi - 1$ avec $s = r - i$ est inversible d'inverse $-(1 + p^s \psi + p^{2s} \psi^2 + \dots)$ et donc $p^r \psi - p^i$ est un p^r -isomorphisme. Il reste à voir le cas $i = r$: on va montrer que $(\psi - 1) : R^{[u,v]} / R^{[u]} \rightarrow R^{[pu,v]} / R^{[pu]}$ est un isomorphisme.

Comme dans la preuve du [lemme 4.6](#), on peut écrire

$$R^{[u,v]} / R^{[u]} = \mathbb{A}^{[u,v]} / \mathbb{A}^{[u]} \hat{\otimes}_{\mathbb{A}_{\text{inf}}} R_{\text{inf}}^+ \cong \mathbb{A}^{(0,v)+} / \mathbb{A}_{\text{inf}} \hat{\otimes}_{\mathbb{A}_{\text{inf}}} R_{\text{inf}}^+.$$

Si x est un monôme $aX_1^{\alpha_1} \dots X_d^{\alpha_d}$ de R_{inf}^+ avec $a \in \mathbb{A}_{\text{inf}}$ et $\alpha = (\alpha_1, \dots, \alpha_d) \neq 0$ alors, par construction de ψ , $(\psi^k(x))_k$ tend vers 0 et la série $x + \psi(x) + \psi^2(x) + \dots$ converge. Il suffit donc de vérifier que $\psi - 1$ est un isomorphisme de $\mathbb{A}^{(0,v)+} / \mathbb{A}_{\text{inf}}$ dans lui-même.

L'injectivité se déduit des suites exactes

$$0 \rightarrow \mathbb{Z}_p \rightarrow \mathbb{A}_{\text{inf}} \xrightarrow{\psi-1} \mathbb{A}_{\text{inf}} \rightarrow 0 \quad \text{et} \quad 0 \rightarrow \mathbb{Z}_p \rightarrow \mathbb{A}^{(0,v/p)+} \xrightarrow{\psi-1} \mathbb{A}^{(0,v)+} \rightarrow 0$$

obtenues à partir des suites exactes (14) et (15).

Montrons la surjectivité. Soit x dans $\mathbb{A}^{(0,v]^+}$. Comme $(1 - \psi)$ est surjective de \mathbb{A} dans \mathbb{A} , il existe y dans \mathbb{A} tel que $x = (1 - \psi)(y)$. On va montrer que $\psi(y)$ est dans $\mathbb{A}^{(0,v]^+}$ (et on aura en particulier que $y = x + \psi(y)$ est dans $\mathbb{A}^{(0,v]^+}$).

Écrivons $x = \sum_{n \in \mathbb{N}} [x_n] p^n$ et $y = \sum_{n \in \mathbb{N}} [y_n] p^n$. On a l'égalité

$$\sum_{n \in \mathbb{N}} [x_n] p^n = \sum_{n \in \mathbb{N}} ([y_n] - [y_n^{1/p}]) p^n.$$

On veut montrer que $v(v_{\mathbb{E}}(y_n)/p) + n$ tend vers l'infini et que $v_{\mathbb{E}}(y_n) \geq -pn/v$. Il suffit de vérifier que $v_{\mathbb{E}}(y_n) \geq -n/v$ pour tout $n \in \mathbb{N}$: on aura alors

$$v_{\mathbb{E}}(y_n) \geq \frac{-n}{v} > \frac{-pn}{v} \quad \text{et} \quad v \frac{v_{\mathbb{E}}(y_n)}{p} + n \geq \frac{p-1}{p} n \xrightarrow{n \rightarrow \infty} \infty.$$

Pour $n = 0$, on a $x_0 = y_0 - y_0^{1/p}$. Si $v_{\mathbb{E}}(y_0) < 0$ alors $v_{\mathbb{E}}(y_0) < v_{\mathbb{E}}(y_0^{1/p})$ et $v_{\mathbb{E}}(y_0) = v_{\mathbb{E}}(x_0) \geq 0$, ce qui est une contradiction. Donc $v_{\mathbb{E}}(y_0) \geq 0$.

Soit n dans \mathbb{N} . Supposons que pour tout $i \leq n$, $v_{\mathbb{E}}(y_i) \geq -n/v$. Dans \mathbb{A} , on a

$$\begin{aligned} & -([x_{n+1}] - [y_{n+1}] + [y_{n+1}^{1/p}]) p^{n+1} \\ & = \left(\sum_{i \leq n} ([x_i] - [y_i] + [y_i^{1/p}]) p^i \right) + p^{n+2} \left(\sum_{i \geq n+2} ([x_i] - [y_i] + [y_i^{1/p}]) p^{i-(n+2)} \right). \end{aligned}$$

En divisant par p^{n+1} et en projetant dans C^b , on obtient que $x_{n+1} - y_{n+1} + y_{n+1}^{1/p}$ est l'image de

$$\frac{1}{p^{n+1}} \sum_{i \leq n} ([x_i] - [y_i] + [y_i^{1/p}]) p^i$$

dans C^b . Mais par hypothèse de récurrence, $[\alpha^n] \left(\sum_{i \leq n} ([x_i] - [y_i] + [y_i^{1/p}]) p^i \right) \in \mathbb{A}^+ \cap p^{n+1} \mathbb{A} = p^{n+1} \mathbb{A}^+$, donc $\alpha^n(x_{n+1} - y_{n+1} + y_{n+1}^{1/p})$ est dans \mathcal{O}^b . On obtient

$$v_{\mathbb{E}}(x_{n+1} - y_{n+1} + y_{n+1}^{1/p}) \geq \frac{-n}{v}.$$

Si $v_{\mathbb{E}}(y_{n+1}) \geq v_{\mathbb{E}}(x_{n+1})$ ou $v_{\mathbb{E}}(y_{n+1}) \geq 0$, on a fini. Si $v_{\mathbb{E}}(y_{n+1}) < v_{\mathbb{E}}(x_{n+1})$ et $v_{\mathbb{E}}(y_{n+1}) < 0$, alors

$$v_{\mathbb{E}}(y_{n+1}) = v_{\mathbb{E}}(x_{n+1} - y_{n+1} + y_{n+1}^{1/p}) \geq \frac{-n}{v} \geq \frac{-(n+1)}{v}.$$

On obtient finalement que $\psi - 1$ est un isomorphisme.

Montrons maintenant le point (2). Par le lemme précédent, il suffit de montrer que $p^r \psi - p^{r+1} : R^{[u,v]} / R^{[u]} \rightarrow R^{[pu,v]} / R^{[pu]}$ est p^r -injectif. On va montrer que $\psi - p : R^{[u,v]} / R^{[u]} \rightarrow R^{[pu,v]} / R^{[pu]}$ est injectif et par le même argument que ci-dessus, cela revient à montrer que

$$\psi - p : \mathbb{A}^{(0,v]^+} / \mathbb{A}_{\text{inf}} \rightarrow \mathbb{A}^{(0,v]^+} / \mathbb{A}_{\text{inf}}$$

est aussi injectif.

Comme $\varphi \circ (\psi - p) = 1 - p\varphi$ et que $1 - p\varphi$ est bijectif sur \mathbb{A}_{inf} (d'inverse $1 + p\varphi + p^2\varphi^2 + \dots$), il suffit de vérifier que

$$1 - p\varphi : \mathbb{A}^{(0,v]^+} \rightarrow \mathbb{A}^{(0,v/p]^+}$$

est injectif.

Soit x dans $\mathbb{A}^{(0,v]^+}$ tel que $(1 - p\varphi)(x) = 0$. Alors, pour tout entier k ,

$$\left(\sum_{n \leq k} p^n \varphi^n \right) (1 - p\varphi)(x) = 0$$

et on obtient

$$x = p^{k+1} \varphi^{k+1}(x) \in (p^{k+1} \mathbb{A}^{(0,v/p^{k+1}]^+}) \subset p^{k+1} \mathbb{A}.$$

Donc

$$x \in \bigcap_{k \geq 0} (p^k \mathbb{A}) = 0. \quad \square$$

Ceci termine la démonstration.

Le résultat suivant se déduit des quasi-isomorphismes des lemmes 4.4, 4.7 et de la remarque 4.5.

Corollaire 4.8. *Si $pu \leq v$, on a un p^{2r} -quasi-isomorphisme*

$$\tau_{\leq r} C(R^{[u]}, r) \xrightarrow{\sim} \tau_{\leq r} C(R^{[u,v]}, r).$$

En combinant les résultats de ces deux sections, on obtient un p^{12r} -quasi-isomorphisme

$$\tau_{\leq r} C(R_{\text{cris}}^+, r) \rightarrow \tau_{\leq r} C(R^{[u,v]}, r). \quad (23)$$

5. Utilisation des (φ, Γ) -modules

On suppose toujours R comme à la section 2B2, avec $\text{Spf}(R)$ connexe. Dans cette section, on définit un isomorphisme $R^{[u,v]} \cong \mathbb{A}_R^{[u,v]}$, où $\mathbb{A}_R^{[u,v]}$ est un anneau muni d'une action du groupe de Galois G_R . Cela va permettre de construire un quasi-isomorphisme entre le complexe $C(R^{[u,v]}, r)$ de la section précédente et un complexe de (φ, Γ) -modules $\text{Kos}(\varphi, \Gamma_R, \mathbb{A}_R^{[u,v]})$ qui intervient dans le calcul de la cohomologie de Galois.

Comme dans [Colmez et Nizioł 2017, §4], la preuve se fait en deux étapes. Premièrement, en divisant par des puissances de t , on transforme l'action des différentielles ∂_i en une action d'une algèbre de Lie, $\text{Lie } \Gamma_R$: cela permet de se débarrasser de la filtration (c'est possible par le lemme 5.3 ci-dessous). On utilise ensuite que les opérateurs τ_i qui sont définis dans le paragraphe suivant et qui traduisent l'action du groupe Γ_R sur l'anneau $\mathbb{A}_R^{[u,v]}$ sont topologiquement nilpotents (pour la topologie μ -adique) pour passer de $\text{Lie } \Gamma_R$ à Γ_R .

Remarque 5.1. (1) Colmez et Nizioł [2017] ne travaillent pas ici avec leur complexe original, soit $\text{Kum}(R_{\overline{\omega}}^{[u,v]}, r)$, mais avec un complexe quasi-isomorphe $\text{Cycl}(R_{\overline{\omega}}^{[u,v]}, r)$. Ce changement de complexe correspond à un changement de la variable *arithmétique* X_0 par une variable *cyclotomique* T sur laquelle on peut définir une action de Γ_R . Dans notre cas, les deux complexes sont confondus.

(2) Dans [Colmez et Nizioł 2017], du fait de la variable supplémentaire T , l'algèbre de Lie obtenue n'est pas commutative. Ce n'est pas le cas ici.

5A. Plongement dans les anneaux de périodes. Pour chaque i de $\{1, \dots, d\}$, on choisit un élément $X_i^b = (X_i, X_i^{1/p}, \dots)$ dans $\mathbb{E}_{\overline{R}}$ et on définit un plongement de $R_{\text{inf}, \square}^+$ dans $\mathbb{A}_{\overline{R}}^{\pm}$ en envoyant X_i sur $[X_i^b]$. On étend le plongement à

$$R_{\text{inf}}^+ \rightarrow \mathbb{A}_{\overline{R}}^+, \quad R_{\text{cris}}^+ \rightarrow \mathbb{A}_{\text{cris}}(\overline{R}), \quad R^{[u]} \rightarrow \mathbb{A}_{\overline{R}}^{[u]}, \quad R^{[u,v]} \rightarrow \mathbb{A}_{\overline{R}}^{[u,v]}, \quad R^{(0,v)+} \rightarrow \mathbb{A}_{\overline{R}}^{(0,v)+}.$$

On note \mathbb{A}_R (respectivement $\mathbb{A}_R^+, \mathbb{A}_{\text{cris}}(R), \mathbb{A}_R^*$) l'image de R_{inf} (respectivement $R_{\text{inf}}^+, R_{\text{cris}}^+, R^*$ pour $\star \in \{[u], [u, v], (0, v)+\}$) par ce plongement. On peut alors définir une action du groupe G_R sur ces anneaux.

On considère

$$R_m^{\square} := \mathcal{O}_C \left\{ X^{1/p^m}, \frac{1}{(X_1 \cdots X_a)^{1/p^m}}, \frac{\varpi^{1/p^m}}{(X_{a+1} \cdots X_{a+b})^{1/p^m}} \right\}$$

et on note R_{∞}^{\square} la complétion p -adique de $\varinjlim R_m^{\square}$. Soient R_m et R_{∞} les complétés p -adiques $R_m^{\square} \widehat{\otimes}_{\mathcal{O}_C} R$ et $R_{\infty}^{\square} \widehat{\otimes}_{\mathcal{O}_C} R$.

On rappelle que $G_R := \text{Gal}(\overline{R}[1/p]/R[1/p])$. On note

$$\Gamma_R := \text{Gal}\left(R_{\infty}^{\square} \left[\frac{1}{p} \right] / R^{\square} \left[\frac{1}{p} \right] \right) = \text{Gal}\left(R_{\infty} \left[\frac{1}{p} \right] / R \left[\frac{1}{p} \right] \right)$$

le groupe des automorphismes de $R_{\infty}[1/p]$ qui fixent $R[1/p]$. On a $\Gamma_R \cong \mathbb{Z}_p^d$.

De plus, comme G_R agit sur $\mathbb{A}_{\overline{R}}$ (resp. $\mathbb{A}_{\text{cris}}(\overline{R})$ et $\mathbb{A}_{\overline{R}}^*$), il agit sur \mathbb{A}_R (resp. $\mathbb{A}_{\text{cris}}(R)$ et \mathbb{A}_R^*) via Γ_R . Si on choisit des générateurs topologiques $\gamma_1, \dots, \gamma_d$ de Γ_R , cette action est donnée par

$$\gamma_k([X_k^b]) = [\varepsilon][X_k^b] \quad \text{et} \quad \gamma_j([X_k^b]) = [X_k^b] \quad \text{si } j \neq k.$$

Remarque 5.2. On note $\tau_j := \gamma_j - 1$. Précisons l'action des τ_j sur \mathbb{A}_R^+ . Comme les γ_j agissent trivialement sur \mathbb{A}_{inf} , on obtient que $\tau_j(R_{\text{inf}, \square}^+) \subseteq \mu R_{\text{inf}, \square}^+$. En utilisant la proposition 2.2 pour $\lambda = \gamma_j$, $I = (\mu)$ et $Z_{\lambda} = Z$, on obtient que $\gamma_j(Z)$ est dans $Z + (\mu)$ et en utilisant l'isomorphisme $\mathbb{A}_R^+ \cong R_{\text{inf}}^+$, on en déduit que $\tau_j(\mathbb{A}_R^+) \subseteq \mu \mathbb{A}_R^+$.

Comme on a $R^{[u,v]} = \mathbb{A}^{[u,v]} \widehat{\otimes}_{\mathbb{A}_{\text{inf}} R_{\text{inf}}^+}$, on a le même résultat pour $\mathbb{A}_R^{[u,v]}$.

5B. Passage des (φ, ϑ) -modules aux (φ, Γ) -modules. On commence par montrer le lemme suivant. Comme pour les preuves précédentes, on ne dispose pas ici de l'interprétation des anneaux $R^{[u]}$ et $R^{[u,v]}$ en anneaux de séries de Laurent. La démonstration se fait en travaillant directement avec les anneaux de périodes et en utilisant la description de la filtration $F^r \mathbb{A}^{[u,v]}$ donnée à la proposition 3.1.

Lemme 5.3. Soit $v/p < 1 < v$ et $u \geq 1/(p-1)$. Alors, l'application ¹⁰ $f \mapsto t^r f$ induit des p^{3r} -isomorphismes $\mathbb{A}_{\bar{R}}^{[u,v]} \rightarrow Fr \mathbb{A}_{\bar{R}}^{[u,v]}$ et $\mathbb{A}_{\bar{R}}^{[u,v/p]} \rightarrow \mathbb{A}_{\bar{R}}^{[u,v/p]}$.

Démonstration. Montrons d'abord la p^{3r} -surjectivité de $t^r : \mathbb{A}_{\bar{R}}^{[u,v]} \rightarrow Fr \mathbb{A}_{\bar{R}}^{[u,v]}$. D'après la proposition 3.1, si y est un élément de $Fr \mathbb{A}_{\bar{R}}^{[u,v]}$, $p^r y$ s'écrit $\xi^r x$ avec x dans $\mathbb{A}_{\bar{R}}^{[u,v]}$: il suffit donc de voir que t divise $p^2 \xi$ dans $\mathbb{A}_{\bar{R}}^{[u,v]}$. On écrit

$$\mu = \tilde{u}_0 t \quad \text{avec} \quad \tilde{u}_0 = \sum_{n \geq 1} \frac{a(n)! p^{\tilde{a}(n)}}{n!} t^{\{n-1\}} \quad \text{où} \quad \begin{cases} \tilde{a}(n) = a(n) & \text{si } b(n) \neq 0, \\ \tilde{a}(n) = a(n) - 1 & \text{si } b(n) = 0, \end{cases}$$

et on en déduit que μ et t engendrent les mêmes idéaux dans \mathbb{A}_{cris} (voir [Fontaine 1994, §5.2.4]). Il suffit alors de vérifier que μ divise $p^2 \xi$. Mais, par définition, $\xi = \mu/\mu_1$ avec $\mu_1 = \varphi^{-1}(\mu)$: on va montrer que p^2/μ_1 est dans $\mathbb{A}_{\bar{R}}^{[u,v]}$.

Pour cela, on montre d'abord que $\mu = u_0[\bar{\mu}]$ avec u_0 unité de $\mathbb{A}_{\bar{R}}^{(0,v/p)^+}$. On suit la preuve d'Andreata et Brinon [2008, proposition 4.2 (d)]. En utilisant que $\varphi(\mu) = (\mu + 1)^p - 1$, on vérifie qu'on a

$$\mu = [\varepsilon] - 1 = [\bar{\mu}] + p[\alpha_1] + p^2[\alpha_2] + \dots \quad \text{avec} \quad v_{\mathbb{E}}(\alpha_n) \geq v_{\mathbb{E}}(\varepsilon^{1/p^n} - 1) = \frac{1}{p^{n-1}(p-1)}.$$

Si on écrit $\alpha_n = \bar{\mu} a_n$ avec a_n dans \mathbb{E} , on a

$$v_{\mathbb{E}}(a_n) \geq \frac{1 - p^n}{p^{n-1}(p-1)} = - \sum_{k=0}^{n-1} p^{k-n+1}.$$

Donc, pour tout $n \geq 1$, $(v/p)v_{\mathbb{E}}(a_n) + n \geq 0$. En notant $u_0 = 1 + p[a_1] + p^2[a_2] + \dots$, on obtient $w_{v/p}(u_0 - 1) > 0$, donc $w_{v/p}(u_0) = 0$ et u_0 est une unité de $\mathbb{A}_{\bar{R}}^{(0,v/p)^+}$.

On montre de même que $\mu_1 = u_1[\bar{\mu}_1]$ avec u_1 unité de $\mathbb{A}_{\bar{R}}^{(0,v)^+}$ (et donc aussi de $\mathbb{A}_{\bar{R}}^{(0,v/p)^+}$). On en déduit

$$\frac{p^2}{\mu_1} = \frac{p^2}{[\bar{\mu}_1]} u_1^{-1} \quad \text{avec} \quad w_v\left(\frac{p^2}{[\bar{\mu}_1]}\right) = \frac{-v}{(p-1)} + 2 > \frac{-p}{p-1} + 2 \geq 0,$$

et on obtient le résultat voulu.

La p^{3r} -surjectivité de $\mathbb{A}_{\bar{R}}^{[u,v/p]} \rightarrow \mathbb{A}_{\bar{R}}^{[u,v/p]}$ s'obtient de la même façon.

On vérifie ensuite la p^{3r} -injectivité. Soit f dans $\mathbb{A}_{\bar{R}}^{[u,v]}$ tel que $t^r f = 0$, on veut montrer $p^{3r} f = 0$. Par ce qu'on a vu plus haut, $\mu^r f = 0 = [\bar{\mu}]^r u_0^r f$ avec u_0 unité de $\mathbb{A}_{\bar{R}}^{(0,v/p)^+}$, donc $[\bar{\mu}]^r f = 0$. Enfin, on peut écrire $p^2 = [\bar{\mu}] \cdot x$ avec x dans $\mathbb{A}_{\bar{R}}^{(0,v/p)^+}$: on a donc

$$p^{3r} f = (px[\bar{\mu}])^r f = 0. \quad \square$$

Remarque 5.4. On suppose $v/p < 1 < v$ et $u \geq 1/(p-1)$.

(1) On en déduit qu'on a un p^{3r} -isomorphisme $\mathbb{A}_{\bar{R}}^{[u,v]} \xrightarrow{\sim} Fr \mathbb{A}_{\bar{R}}^{[u,v]}$ (et $\mathbb{A}_{\bar{R}}^{[u,v/p]} \xrightarrow{\sim} \mathbb{A}_{\bar{R}}^{[u,v/p]}$).

10. Bien définie, car on a $t \in \mathbb{A}_{\text{cris}}(\bar{R}) \subset \mathbb{A}_{\bar{R}}^{[u]}$.

(2) La même preuve montre que le morphisme $f \mapsto t^{r+1}f$ de $\mathbb{A}_{\overline{R}}^{[u,v]} \rightarrow F^r \mathbb{A}_{\overline{R}}^{[u,v]}$ et $\mathbb{A}_{\overline{R}}^{[u,v/p]} \rightarrow \mathbb{A}_{\overline{R}}^{[u,v/p]}$ est $p^{2(r+1)}$ -injectif.

(3) On va montrer que les applications précédentes induisent des p^{6r} -isomorphismes

$$\mathbb{A}_{\overline{R}}^{[u,v]}/p^n \rightarrow F^r \mathbb{A}_{\overline{R}}^{[u,v]}/p^n \quad \text{et} \quad \mathbb{A}_{\overline{R}}^{[u,v/p]}/p^n \rightarrow \mathbb{A}_{\overline{R}}^{[u,v/p]}/p^n.$$

Pour cela, notons $A = \mathbb{A}_{\overline{R}}^{[u,v]}$ (respectivement $\mathbb{A}_{\overline{R}}^{[u,v/p]}$) et $B = F^r \mathbb{A}_{\overline{R}}^{[u,v]}$ (respectivement $\mathbb{A}_{\overline{R}}^{[u,v/p]}$) et montrons que $x \mapsto t^r x$ induit un p^{6r} -isomorphisme de A/p^n dans B/p^n . La surjectivité découle du lemme précédent de manière évidente. Montrons la p^{6r} -injectivité : soit x dans A tel que $t^r x = p^n y$ pour y dans B . On a ensuite $p^{3r} t^r x = p^n (p^{3r} y) = p^n (t^r z)$ avec z dans A (on utilise ici la p^{3r} -surjectivité). Ainsi $t^r (p^{3r} x - p^n z)$ est nul et on déduit que $p^{3r} (p^{3r} x - p^n z) = 0$. On obtient que $p^{6r} x$ est nul modulo $p^n A$ et donc que t^r est p^{6r} -injective modulo p^n .

Dans la suite, pour simplifier, on note $S = \mathbb{A}_{\overline{R}}^{[u,v]}$ et $S' = \mathbb{A}_{\overline{R}}^{[u,v/p]}$. On rappelle qu'on a choisi $(\gamma_j)_{1 \leq j \leq d}$ des générateurs topologiques de $\Gamma_R \cong \mathbb{Z}_p^d$ et, pour $1 \leq i \leq d$, on définit $\partial_i := X_i (\partial / \partial X_i)$ et $J_i := \{(j_1, \dots, j_i) \mid 1 \leq j_1 \leq \dots \leq j_i \leq d\}$.

On note $\chi : G_K \rightarrow \mathbb{Z}_p^\times$ le caractère cyclotomique. Pour tout g de G_K , on a $g \cdot t = \chi(g)t$. Si on note $S(r)$ l'anneau S muni de l'action de G_K tordue par χ^r , on obtient que la multiplication par t^r induit une application Galois-invariante $S(r) \rightarrow S$.

On définit les complexes

$$\begin{aligned} \text{Kos}(\Gamma_R, S(r)) &:= S(r) \xrightarrow{(\gamma_j-1)} S(r)^{J_1} \rightarrow \dots \rightarrow S(r)^{J_d}, \\ \text{Kos}(\varphi, \Gamma_R, S(r)) &:= [\text{Kos}(\Gamma_R, S(r)) \xrightarrow{1-\varphi} \text{Kos}(\Gamma_R, S'(r))], \\ \text{Kos}(\partial, F^r S) &:= F^r S \xrightarrow{(\partial_j)} (F^{r-1} S)^{J_1} \rightarrow \dots \rightarrow (F^{r-d} S)^{J_d}, \\ \text{Kos}(\varphi, \partial, F^r S) &:= [\text{Kos}(\partial, F^r S) \xrightarrow{p^r - p^\bullet \varphi} \text{Kos}(\partial, S')]. \end{aligned}$$

On a $C(S, r) \xrightarrow{\sim} \text{Kos}(\varphi, \partial, S)$, et en utilisant l'isomorphisme $R^{[u,v]} \xrightarrow{\sim} A_{\overline{R}}^{[u,v]}$, on obtient $C(S, r) \xrightarrow{\sim} \text{Kos}(\varphi, \partial, F^r S)$.

Le but est maintenant de prouver la proposition suivante (voir [Colmez et Nizioł 2017, Proposition 4.2] pour l'analogie arithmétique) :

Proposition 5.5. (1) Il existe un p^{30r} -quasi-isomorphisme

$$\tau_{\leq r} \text{Kos}(\varphi, \Gamma_R, S(r)) \xrightarrow{\sim} \tau_{\leq r} \text{Kos}(\varphi, \partial, F^r S).$$

(2) Il existe un p^{58r} -quasi-isomorphisme

$$\tau_{\leq r} \text{Kos}(\varphi, \Gamma_R, S(r))_n \xrightarrow{\sim} \tau_{\leq r} \text{Kos}(\varphi, \partial, F^r S)_n,$$

où $(\cdot)_n$ désigne la réduction modulo p^n .

Pour montrer cela, on définit $\nabla_j := t \partial_j$ et on considère l’algèbre de Lie associée au groupe Γ_R , $\text{Lie } \Gamma_R$. Alors $\text{Lie } \Gamma_R$ est un \mathbb{Z}_p -module libre de rang d , engendré par les ∇_j pour $1 \leq j \leq d$. On note

$$\begin{aligned} \text{Kos}(\text{Lie } \Gamma_R, S(r)) &:= S(r) \xrightarrow{(\nabla_j)} S(r)^{J_1} \rightarrow \dots \rightarrow S(r)^{J_d}, \\ \text{Kos}(\varphi, \text{Lie } \Gamma_R, S(r)) &:= [\text{Kos}(\text{Lie } \Gamma_R, S(r)) \xrightarrow{1-\varphi} \text{Kos}(\text{Lie } \Gamma_R, S'(r))]. \end{aligned}$$

Lemme 5.6. (1) Il existe un p^{30r} -quasi-isomorphisme

$$\tau_{\leq r} \text{Kos}(\varphi, \text{Lie } \Gamma_R, S(r)) \xrightarrow{\sim} \tau_{\leq r} \text{Kos}(\varphi, \partial, F^r S).$$

(2) De même, il existe un p^{58r} -quasi-isomorphisme

$$\tau_{\leq r} \text{Kos}(\varphi, \text{Lie } \Gamma_R, S(r))_n \xrightarrow{\sim} \tau_{\leq r} \text{Kos}(\varphi, \partial, F^r S)_n.$$

Démonstration. On rappelle qu’on note $S = \mathbb{A}_R^{[u,v]}$ et $S' = \mathbb{A}_R^{[u,v/p]}$. Comme dans [Colmez et Nizioł 2017, Lemma 4.4], on déduit du lemme 5.3 et des diagrammes

$$\begin{array}{ccccccc} S(r) & \xrightarrow{(\nabla_j)} & S(r)^{J_1} & \longrightarrow & \dots & \longrightarrow & S(r)^{J_r} & \longrightarrow & S(r)^{J_{r+1}} & \longrightarrow & \dots \\ t^r \downarrow & & t^r \downarrow & & & & t^r \downarrow & & t^r \downarrow & & \\ F^r S & \xrightarrow{(\nabla_j)} & (F^r S)^{J_1} & \longrightarrow & \dots & \longrightarrow & (F^r S)^{J_r} & \longrightarrow & (F^r S)^{J_{r+1}} & \longrightarrow & \dots \\ \uparrow t^0 & & \uparrow t^1 & & & & \uparrow t^r & & \uparrow t^{r+1} & & \\ F^r S & \xrightarrow{(\partial_j)} & (F^{r-1} S)^{J_1} & \longrightarrow & \dots & \longrightarrow & S^{J_r} & \longrightarrow & S^{J_{r+1}} & \longrightarrow & \dots \end{array}$$

et

$$\begin{array}{ccccccc} S'(r) & \xrightarrow{(\nabla_j)} & S'(r)^{J_1} & \longrightarrow & \dots & \longrightarrow & S'(r)^{J_r} & \longrightarrow & S'(r)^{J_{r+1}} & \longrightarrow & \dots \\ t^r \downarrow & & t^r \downarrow & & & & t^r \downarrow & & t^r \downarrow & & \\ S' & \xrightarrow{(\nabla_j)} & (S')^{J_1} & \longrightarrow & \dots & \longrightarrow & (S')^{J_r} & \longrightarrow & (S')^{J_{r+1}} & \longrightarrow & \dots \\ \uparrow t^0 & & \uparrow t^1 & & & & \uparrow t^r & & \uparrow t^{r+1} & & \\ S' & \xrightarrow{(\partial_j)} & (S')^{J_1} & \longrightarrow & \dots & \longrightarrow & (S')^{J_r} & \longrightarrow & (S')^{J_{r+1}} & \longrightarrow & \dots \end{array}$$

qu’on a des p^{14r} -quasi-isomorphismes

$$\tau_{\leq r} \text{Kos}(\text{Lie } \Gamma_R, S(r)) \xrightarrow{\sim} \tau_{\leq r} \text{Kos}(\partial, F^r S) \quad \text{et} \quad \tau_{\leq r} \text{Kos}(\text{Lie } \Gamma_R, S'(r)) \xrightarrow{\sim} \tau_{\leq r} \text{Kos}(\partial, S').$$

En effet, par le lemme, les flèches verticales du haut sont des p^{3r} -isomorphismes et on obtient donc un p^{6r} -quasi-isomorphisme entre les deux premiers complexes. De la même façon, les flèches du bas sont des p^{3r} -isomorphismes en degré inférieur à r . En degré $(r + 1)$, d’après la remarque 5.4, le morphisme $S \xrightarrow{t^{r+1}} F^r S$ est p^{4r} -injectif et on en déduit le p^{8r} -quasi-isomorphisme entre les complexes tronqués.

Comme on a

$$\begin{aligned} \text{Kos}(\varphi, \text{Lie } \Gamma_R, S(r)) &:= [\text{Kos}(\text{Lie } \Gamma_R, S(r)) \xrightarrow{1-\varphi} \text{Kos}(\text{Lie } \Gamma_R, S'(r))], \\ \text{Kos}(\varphi, \partial, F^r S) &:= [\text{Kos}(\partial, F^r S) \xrightarrow{p^r - p^\bullet \varphi} \text{Kos}(\partial, S')], \end{aligned}$$

on obtient un p^{30r} -quasi-isomorphisme

$$\tau_{\leq r} \text{Kos}(\varphi, \text{Lie } \Gamma_R, S(r)) \xrightarrow{\sim} \tau_{\leq r} \text{Kos}(\varphi, \partial, F^r S)$$

induit par le diagramme commutatif

$$\begin{array}{ccc} \text{Kos}(\text{Lie } \Gamma_R, S(r)) & \xrightarrow{1-\varphi} & \text{Kos}(\text{Lie } \Gamma_R, S'(r)) \\ \downarrow & & \downarrow p^r \\ \text{Kos}(\text{Lie } \Gamma_R, S(r)) & \xrightarrow{p^r(1-\varphi)} & \text{Kos}(\text{Lie } \Gamma_R, S'(r)) \\ \downarrow t^r & & \downarrow t^r \\ \text{Kos}(\text{Lie } \Gamma_R, F^r S) & \xrightarrow{p^r-\varphi} & \text{Kos}(\text{Lie } \Gamma_R, S') \\ \uparrow t^\bullet & & \uparrow t^\bullet \\ \text{Kos}(\partial, F^r S) & \xrightarrow{p^r-p^\bullet\varphi} & \text{Kos}(\partial, S') \end{array} \tag{24}$$

Le résultat modulo p^n s'obtient de la même façon, en utilisant le dernier point de la [remarque 5.4](#). \square

Remarque 5.7. En degré supérieur à $r + 1$, les flèches du bas dans le diagramme ci-dessus ne sont plus surjectives et, sans la troncation, on perd le quasi-isomorphisme entre la deuxième et la troisième ligne.

Lemme 5.8. *Il existe un quasi-isomorphisme*

$$\text{Kos}(\varphi, \Gamma_R, S(r)) \xrightarrow{\sim} \text{Kos}(\varphi, \text{Lie } \Gamma_R, S(r)).$$

Démonstration. La preuve est semblable à celle de [[Colmez et Nizioł 2017](#), Proposition 4.5]. On va construire une application $\beta : \text{Kos}(\Gamma_R, S(r)) \rightarrow \text{Kos}(\text{Lie } \Gamma_R, S(r))$ telle que le diagramme

$$\begin{array}{ccccccc} S(r) & \xrightarrow{(\gamma_j-1)} & S(r)^{J_1} & \longrightarrow & S(r)^{J_2} & \longrightarrow & \dots \\ \text{Id} \downarrow & & \beta_1 \downarrow & & \beta_2 \downarrow & & \\ S(r) & \xrightarrow{(\nabla_j)} & S(r)^{J_1} & \longrightarrow & S(r)^{J_2} & \longrightarrow & \dots \end{array}$$

soit commutatif, et qui induit le quasi-isomorphisme voulu.

On rappelle qu'on a noté $\tau_j := \gamma_j - 1$.

Soient $(a_n)_{n \geq 1}$ et $(b_n)_{n \geq 1}$ les coefficients des séries formelles

$$\frac{\log(1+X)}{X} = 1 + a_1 X + a_2 X^2 + \dots \quad \text{et} \quad \frac{X}{\log(1+X)} = 1 + b_1 X + b_2 X^2 + \dots .$$

Pour tout $j \in \{1, \dots, d\}$, on pose

$$s_j := 1 + a_1 \tau_j + a_2 \tau_j^2 + \dots \quad \text{et} \quad s_j^{-1} := 1 + b_1 \tau_j + b_2 \tau_j^2 + \dots.$$

En utilisant la [remarque 5.2](#), on voit que pour x dans $\mathbb{A}_R^{[u,v]}$, les séries $s_j(x)$ et $s_j^{-1}(x)$ convergent dans $\mathbb{A}_R^{[u,v]}$.

Considérons maintenant les applications $\beta_i : S(r)^{J_i} \rightarrow S(r)^{J_i}$ avec $\beta_i((a_j)_{j \in J_i}) = (s_{j_1} \cdots s_{j_i}(a_j))_{j \in J_i}$. Par ce qu'on vient de voir, les β_i sont bien définies et sont des isomorphismes.

Il reste à voir que le diagramme commute. Mais on a

$$(s_{j_1} \cdots s_{j_i} \tau_{j_i} \cdots \tau_{j_1}) = (s_{j_1} \cdots s_{j_{i-1}} \nabla_{j_i} \tau_{j_{i-1}} \cdots \tau_{j_1}) = \dots = (\nabla_{j_1} \cdots \nabla_{j_i})$$

car ∇_j et τ_j commutent (comme on a tordu l'action par χ).

Enfin, en remarquant que $\beta \circ \varphi = \varphi \circ \beta$, on obtient que l'application β nous donne bien le quasi-isomorphisme cherché. □

Remarque 5.9. La convergence des séries s_j et s_j^{-1} se déduit ici directement de la définition de l'action des τ_j sur $\mathbb{A}_R^{[u,v]}$. Dans [\[Colmez et Nizioł 2017\]](#), du fait de la variable supplémentaire T , la preuve de cette convergence est plus technique et s'obtient, là encore, par des considérations sur des séries de Laurent ; voir [\[Colmez et Nizioł 2017, §2.5.3\]](#).

La [proposition 5.5](#) se déduit ensuite des deux précédents lemmes.

5C. Changement d'anneau. Pour terminer, on passe de l'anneau $\mathbb{A}_R^{[u,v]}$ à \mathbb{A}_R .

Lemme 5.10. *L'inclusion $\mathbb{A}_R^{(0,v)+} \hookrightarrow \mathbb{A}_R^{[u,v]}$ induit un quasi-isomorphisme*

$$\text{Kos}(\varphi, \Gamma_R, \mathbb{A}_R^{(0,v)+}(r)) \xrightarrow{\sim} \text{Kos}(\varphi, \Gamma_R, \mathbb{A}_R^{[u,v]}(r)).$$

Démonstration. L'idée est la même que dans [\[Colmez et Nizioł 2017, Lemma 4.8\]](#) : on vérifie que $1 - \varphi : \mathbb{A}_R^{[u,v]} / \mathbb{A}_R^{(0,v)+} \rightarrow \mathbb{A}_R^{[u,v/p]} / \mathbb{A}_R^{(0,v/p)+}$ est un isomorphisme. Comme on a un isomorphisme entre $\mathbb{A}_R^{[u,v]} / \mathbb{A}_R^{(0,v)+}$ et $\mathbb{A}_R^{[u,v/p]} / \mathbb{A}_R^{(0,v/p)+}$, on peut voir $1 - \varphi$ comme un endomorphisme de $\mathbb{A}_R^{[u,v]} / \mathbb{A}_R^{(0,v)+}$.

On a de plus

$$\varphi \left(\frac{[\beta]^n}{p^n} \right) = \frac{[\beta]^{pn}}{p^n} = p^{(p-1)n} \frac{[\beta]^{pn}}{p^{pn}}.$$

On en déduit que $\varphi(\mathbb{A}_R^{[u,v]} / \mathbb{A}_R^{(0,v)+}) \subseteq p \cdot (\mathbb{A}_R^{[u,v]} / \mathbb{A}_R^{(0,v)+})$ et par itération,

$$\varphi^k (\mathbb{A}_R^{[u,v]} / \mathbb{A}_R^{(0,v)+}) \subseteq p^k \cdot (\mathbb{A}_R^{[u,v]} / \mathbb{A}_R^{(0,v)+}).$$

On obtient que φ est topologiquement nilpotent et $(1 - \varphi)$ inversible. □

Pour $S = \mathbb{A}_R, \mathbb{A}_R^{(0,v)+}$, on note $\text{Kos}(\psi, \Gamma_R, S) := [\text{Kos}(\Gamma_R, S) \xrightarrow{\psi^{-1}} \text{Kos}(\Gamma_R, S)]$.

Remarque 5.11. Dans [\[Colmez et Nizioł 2017\]](#), l'anneau $\mathbb{A}_R^{(0,v)+}$ n'est pas stable par ψ et il est nécessaire de multiplier $\mathbb{A}_R^{(0,v)+}$ par une constante π_i^{-l} dans la définition de $\text{Kos}(\psi, \Gamma_R, \mathbb{A}_R^{(0,v)+})$.

Lemme 5.12. *L'application*

$$\begin{array}{ccc} \text{Kos}(\Gamma_R, \mathbb{A}_R^{(0,v]^{+}}) & \xrightarrow{1-\varphi} & \text{Kos}(\Gamma_R, \mathbb{A}_R^{(0,v/p]^{+}}) \\ \downarrow \text{Id} & & \downarrow \psi \\ \text{Kos}(\Gamma_R, \mathbb{A}_R^{(0,v]^{+}}) & \xrightarrow{\psi^{-1}} & \text{Kos}(\Gamma_R, \mathbb{A}_R^{(0,v]^{+}}) \end{array}$$

induit un quasi-isomorphisme $\text{Kos}(\varphi, \Gamma_R, S) \xrightarrow{\sim} \text{Kos}(\psi, \Gamma_R, S)$.

Démonstration. Le raisonnement est semblable à celui de la preuve du [lemme 4.4](#) : comme ψ est surjective, il suffit de vérifier que $\text{Kos}(\Gamma_R, \mathbb{A}_R^{(0,v/p]^{+}})^{\psi=0}$ est acyclique. On utilise la décomposition de la [remarque 3.10](#) et on est ramené à prouver que $\text{Kos}(\Gamma_R, \varphi(\mathbb{A}_R^{(0,v/p]^{+}})u_\alpha)$ est acyclique pour tout $\alpha = (\alpha_1, \dots, \alpha_d) \neq 0$.

Soit alors k tel que $\alpha_k \neq 0$. On peut supposer que $k = d$. Pour simplifier, on pose $M_\alpha = \varphi(\mathbb{A}_R^{(0,v]^{+}})u_\alpha$. On note $J'_i := \{(j_1, \dots, j_i) \mid 1 \leq j_1 < \dots < j_i \leq d-1\}$ et on écrit $\text{Kos}(\Gamma_R, M_\alpha)$ comme le complexe

$$\begin{array}{ccccccc} M_\alpha & \xrightarrow{(\tau_j)_{j \neq d}} & (M_\alpha)^{J'_1} & \longrightarrow & (M_\alpha)^{J'_2} & \longrightarrow & \dots \\ \downarrow \tau_d & & \downarrow \tau_d & & \downarrow \tau_d & & \\ M_\alpha & \xrightarrow{(\tau_j)_{j \neq d}} & (M_\alpha)^{J'_1} & \longrightarrow & (M_\alpha)^{J'_2} & \longrightarrow & \dots \end{array}$$

On va montrer que τ_d est bijective sur M_α . Comme M_α est p -adiquement complet, il suffit de montrer la surjectivité modulo p .

On a $\gamma_d \cdot u_\alpha = (\bar{\mu} + 1)^{\alpha_d} u_\alpha$ et donc, pour y dans $(\mathbb{A}_R^{(0,v]^{+}}/p)$,

$$(\gamma_d - 1) \cdot (\varphi(y)u_\alpha) = \varphi(\bar{\mu}_1 G(y))u_\alpha$$

avec $\bar{\mu}_1 = \varphi^{-1}(\bar{\mu})$ et $G(y) = (1 + \bar{\mu}_1)^{\alpha_d} \bar{\mu}_1^{-1} (\gamma_d - 1)y + \bar{\mu}_1^{-1} ((1 + \bar{\mu}_1)^{\alpha_d} - 1)y$. Mais l'action de $(\gamma_d - 1)$ est triviale modulo $\bar{\mu}$ (car, modulo $\bar{\mu}$, $\varepsilon = 1$) et comme $\bar{\mu} = \bar{\mu}_1^p$, on obtient que, modulo $\bar{\mu}_1$, $G(y) = \alpha_d y$. On a alors que l'application $\varphi \circ G : (\mathbb{A}_R^{(0,v]^{+}}/p) \rightarrow (\mathbb{A}_R^{(0,v/p]^{+}}/p)$ est surjective modulo $\bar{\mu}$ et comme $(\mathbb{A}_R^{(0,v]^{+}}/p)$ est $\bar{\mu}$ -complet, on en déduit que $\varphi \circ G$ est surjective et que $(\gamma_d - 1)$ est surjective sur M_α . □

Lemme 5.13. *L'inclusion $\mathbb{A}_R^{(0,v]^{+}} \hookrightarrow \mathbb{A}_R$ induit un quasi-isomorphisme*

$$\text{Kos}(\psi, \Gamma_R, \mathbb{A}_R^{(0,v]^{+}}) \xrightarrow{\sim} \text{Kos}(\psi, \Gamma_R, \mathbb{A}_R).$$

Démonstration. Comme dans [[Colmez et Nizioł 2017](#), Lemma 4.12], il suffit de voir que $1 - \psi : \mathbb{A}_R/\mathbb{A}_R^{(0,v]^{+}} \rightarrow \mathbb{A}_R/\mathbb{A}_R^{(0,v]^{+}}$ est un isomorphisme. De la même façon que dans la preuve du [lemme 4.7](#), en remarquant que $1 + \psi + \psi^2 + \dots$ converge sur les monômes, on se ramène à montrer le résultat pour l'anneau $\mathbb{A}/\mathbb{A}^{(0,v]^{+}}$. Mais on a montré au [lemme 4.7](#) que $1 - \psi$ était surjective de $\mathbb{A}^{(0,v]^{+}}$ dans lui-même et on obtient donc que $1 - \psi$ est un isomorphisme sur le quotient. □

On en déduit la proposition suivante :

Proposition 5.14. *On a un quasi-isomorphisme*

$$\text{Kos}(\varphi, \Gamma_R, \mathbb{A}_R^{(0,v]^+}) \xrightarrow{\sim} \text{Kos}(\varphi, \Gamma_R, \mathbb{A}_R).$$

Enfin, en combinant tous les résultats de cette section, on obtient :

Proposition 5.15. *Il existe un quasi-isomorphisme*

$$\text{Kos}(\varphi, \Gamma_R, \mathbb{A}_R^{[u,v]}(r)) \xrightarrow{\sim} \text{Kos}(\varphi, \Gamma_R, \mathbb{A}_R(r)).$$

Remarque 5.16. On peut montrer également que l’inclusion $\mathbb{A}_R^+ \hookrightarrow \mathbb{A}_R^{[u,v]}$ induit un quasi-isomorphisme $\text{Kos}(\varphi, \Gamma_R, \mathbb{A}_R^+(r)) \xrightarrow{\sim} \text{Kos}(\varphi, \Gamma_R, \mathbb{A}_R^{[u,v]}(r))$. En effet, par ce qu’on vient de voir, il reste à vérifier que l’inclusion $\mathbb{A}_R^+ \hookrightarrow \mathbb{A}_R^{(0,v]^+}$ donne un quasi-isomorphisme $\text{Kos}(\psi, \Gamma_R, \mathbb{A}_R^+) \xrightarrow{\sim} \text{Kos}(\psi, \Gamma_R, \mathbb{A}_R^{(0,v]^+})$. Pour cela, il suffit de prouver que $1 - \psi : \mathbb{A}_R^{(0,v]^+} / \mathbb{A}_R^+ \rightarrow \mathbb{A}_R^{(0,v]^+} / \mathbb{A}_R^+$ est un isomorphisme, ce qui est montré dans la preuve du [lemme 4.7](#).

6. Cohomologie de Galois

Soit R comme dans les sections précédentes. Pour terminer la preuve du théorème de comparaison locale [2.4](#), il reste à voir qu’on a un quasi-isomorphisme $R\Gamma(\Gamma_R, \mathbb{A}_R) \cong R\Gamma(G_R, \mathbb{A}_{\bar{R}})$. Ce résultat s’obtient via des arguments classiques de descente presque étale et de décomplétion.

6A. Calcul de la cohomologie de Galois. Le but de cette partie est de montrer qu’on a un quasi-isomorphisme

$$[R\Gamma(\Gamma_R, \mathbb{A}_R(r)) \xrightarrow{1-\varrho} R\Gamma(\Gamma_R, \mathbb{A}_R(r))] \xleftarrow{\sim} R\Gamma(G_R, \mathbb{Z}_p(r)). \tag{25}$$

Comme la suite exacte

$$0 \rightarrow \mathbb{Z}_p \rightarrow \mathbb{A}_{\bar{R}} \xrightarrow{1-\varrho} \mathbb{A}_{\bar{R}} \rightarrow 0$$

donne un quasi-isomorphisme

$$R\Gamma(G_R, \mathbb{Z}_p(r)) \xrightarrow{\sim} [R\Gamma(G_R, \mathbb{A}_{\bar{R}}(r)) \xrightarrow{1-\varrho} R\Gamma(G_R, \mathbb{A}_{\bar{R}}(r))],$$

il suffit de vérifier qu’on a un quasi-isomorphisme

$$R\Gamma(\Gamma_R, \mathbb{A}_R(r)) \xrightarrow{\sim} R\Gamma(G_R, \mathbb{A}_{\bar{R}}(r)).$$

Soit \tilde{R}_∞ la clôture intégrale de R dans la sous- $R[1/p]$ -algèbre de $\bar{R}[1/p]$ engendrée pour $m \geq 1$ par les $X_{a+b+1}^{1/m}, \dots, X_d^{1/m}$ et pour $n \geq 1$ par les $X_1^{1/p^n}, \dots, X_d^{1/p^n}$. La même preuve que dans [\[Colmez et Nizioł 2017, Lemma 5.8\]](#) donne :

Proposition 6.1. \bar{R} est l’extension maximale de \tilde{R}_∞ telle que $\bar{R}[1/p] / \tilde{R}_\infty[1/p]$ est étale.

On note $\mathbb{E}_{\tilde{R}_\infty}$ le tilt de la complétion de \tilde{R}_∞ , $\mathbb{A}_{\tilde{R}_\infty} = W(\mathbb{E}_{\tilde{R}_\infty})$ et $\tilde{\Gamma}_R := \text{Gal}(\widehat{\tilde{R}_\infty}[1/p] / R[1/p])$. Enfin, soit $H_R := \ker(G_R \rightarrow \tilde{\Gamma}_R)$. On déduit de la proposition précédente le résultat suivant, le raisonnement étant identique à celui de [\[Andreatta et Brinon 2008, §2; Andreatta et Iovita 2008, Appendix A; Colmez 2003\]](#) :

Proposition 6.2 [Colmez et Nizioł 2017, Proposition 4.13]. (1) Pour tout $i \geq 1$, on a $H^i(H_R, \mathbb{A}_{\bar{R}}) = 0$.
En particulier, on a un quasi-isomorphisme

$$R\Gamma(\tilde{\Gamma}_R, \mathbb{A}_{\tilde{R}_\infty}(r)) \xrightarrow{\sim} R\Gamma(G_R, \mathbb{A}_{\bar{R}}(r)).$$

(2) Il existe un quasi-isomorphisme

$$R\Gamma(\Gamma_R, \mathbb{A}_{R_\infty}(r)) \xrightarrow{\sim} R\Gamma(\tilde{\Gamma}_R, \mathbb{A}_{\tilde{R}_\infty}(r)).$$

Dans la suite, on note μ_H le morphisme $R\Gamma(\Gamma_R, \mathbb{A}_{R_\infty}(r)) \rightarrow R\Gamma(G_R, \mathbb{A}_{\bar{R}}(r))$. On passe de l'anneau \mathbb{A}_{R_∞} à \mathbb{A}_R via un argument de décomplétion (voir [Andreatta et Iovita 2008, Theorem A.14; Kedlaya et Liu 2016]) :

Proposition 6.3 [Colmez et Nizioł 2017, Proposition 4.13]. On a un quasi-isomorphisme

$$\mu_\infty : R\Gamma(\Gamma_R, \mathbb{A}_R(r)) \xrightarrow{\sim} R\Gamma(\Gamma_R, \mathbb{A}_{R_\infty}(r)).$$

6B. Comparaison avec le complexe syntomique. On peut maintenant montrer le théorème suivant :

Théorème 6.4. Il existe une constante N indépendante de R telle qu'on a des p^{Nr} -quasi-isomorphismes

$$\begin{aligned} \alpha_r : \tau_{\leq r} \text{Syn}(R, r) &\rightarrow \tau_{\leq r} R\Gamma(G_R, \mathbb{Z}_p(r)), \\ \alpha_{r,n} : \tau_{\leq r} \text{Syn}(R, r)_n &\rightarrow \tau_{\leq r} R\Gamma(G_R, \mathbb{Z}/p^n(r)). \end{aligned}$$

Démonstration. On vient de voir qu'on avait un quasi-isomorphisme

$$[R\Gamma(\Gamma_R, \mathbb{A}_R(r)) \xrightarrow{1-\varphi} R\Gamma(\Gamma_R, \mathbb{A}_R(r))] \leftarrow \simeq R\Gamma(G_R, \mathbb{Z}_p(r)).$$

Mais $R\Gamma(\Gamma_R, \mathbb{A}_R(r))$ est calculé par le complexe $\text{Kos}(\Gamma_R, \mathbb{A}_R(r))$ et on a un quasi-isomorphisme naturel

$$R\Gamma(G_R, \mathbb{Z}_p(r)) \xrightarrow{\sim} \text{Kos}(\varphi, \Gamma_R, \mathbb{A}_R(r)).$$

D'après la proposition 5.5, on a un p^{30r} -quasi-isomorphisme

$$\tau_{\leq r} \text{Kos}(\varphi, \Gamma_R, \mathbb{A}_R^{[u,v]}(r)) \xrightarrow{\sim} \tau_{\leq r} \text{Kos}(\varphi, \partial, F^r \mathbb{A}_R^{[u,v]}),$$

et en utilisant le quasi-isomorphisme de la proposition 5.15,

$$\text{Kos}(\varphi, \Gamma_R, \mathbb{A}_R^{[u,v]}(r)) \xrightarrow{\sim} \text{Kos}(\varphi, \Gamma_R, \mathbb{A}_R(r)),$$

on en déduit un p^{30r} -quasi-isomorphisme

$$\tau_{\leq r} R\Gamma(G_R, \mathbb{Z}_p(r)) \xrightarrow{\sim} \tau_{\leq r} \text{Kos}(\varphi, \partial, F^r \mathbb{A}_R^{[u,v]}).$$

Enfin, en utilisant l'isomorphisme naturel $\mathbb{A}_R^{[u,v]} \cong R^{[u,v]}$ et le p^{12r} -quasi-isomorphisme $\text{Syn}(R_{\text{cris}}^+, r) \xrightarrow{\sim} C(R^{[u,v]}, r)$ établi dans la section 4, on obtient le p^{Nr} -quasi-isomorphisme α_r (avec $N = 42$). La même démonstration donne un p^{Nr} -quasi-isomorphisme $\alpha_{r,n}$ pour $N = 70$. \square

7. Comparaison locale avec l’application de Fontaine–Messing

Dans cette partie, on montre que le morphisme de périodes local construit dans la section précédente est égal à l’application de Fontaine–Messing modulo une certaine puissance de p . Une fois la construction du morphisme établie, la preuve est très similaire à celle du cas arithmétique [Colmez et Nizioł 2017, §4.7]. On suppose toujours $\mathfrak{X} = \text{Spf}(R)$ connexe.

7A. Anneaux $\mathbb{E}_{\bar{R}}^{[u,v]}$ et $\mathbb{E}_{\bar{R}}^{PD}$ et lemmes de Poincaré. On rappelle ici la définition de $\mathbb{E}_{\bar{R}}^{[u,v]}$ et $\mathbb{E}_{\bar{R}}^{PD}$ donnée dans [Colmez et Nizioł 2017, §2.6] et les lemmes de Poincaré vérifiés par ces anneaux.

7A1. Définition des anneaux SA . Dans cette section, S désignera l’anneau R_{cris}^+ (respectivement $R^{[u,v]}$) et A désignera $\mathbb{A}_{\text{cris}}(\bar{R})$ ou $\mathbb{A}_{\text{cris}}(R)$ (respectivement $\mathbb{A}_{\bar{R}}^{[u,v]}$ ou $\mathbb{A}_R^{[u,v]}$). On a donc un morphisme injectif continu $\iota : S \rightarrow A$ et, si B désigne l’anneau \mathbb{A}_{cris} (respectivement $\mathbb{A}^{[u,v]}$), on note $f : S \otimes_B A \rightarrow A$ le morphisme tel que $f(x \otimes y) = \iota(x)y$.

On note SA la log-PD-enveloppe complétée de $S \otimes_B A \rightarrow A$ par rapport à $\ker(f)$. Plus explicitement, si $V_j = (X_j \otimes 1)/(1 \otimes \iota(X_j))$ pour $1 \leq j \leq d$, alors SA est la complétion p -adique de $S \otimes_B A$ à laquelle on ajoute tous les $(x \otimes 1 - 1 \otimes \iota(x))^{[k]}$ pour x dans S et les $(V_j - 1)^{[k]}$. On munit SA d’une filtration en définissant $F^r SA$ comme l’adhérence de l’idéal engendré par les éléments de la forme

$$x_1 x_2 \prod_{1 \leq j \leq d} (V_j - 1)^{[k_j]},$$

où x_1 est dans $F^{r_1} S$, x_2 est dans $F^{r_2} A$ et $r_1 + r_2 + \sum_{j=1}^d k_j \leq r$.

Proposition 7.1 [Colmez et Nizioł 2017, Lemma 2.36]. (1) *Tout x de SA s’écrit de manière unique sous la forme*

$$x = \sum_{\mathbf{k}=(k_1, \dots, k_d) \in \mathbb{N}^d} x_{\mathbf{k}} \prod_{j=1}^d (1 - V_j)^{[k_j]}, \tag{26}$$

avec $x_{\mathbf{k}}$ dans A qui tend vers 0 quand \mathbf{k} tend vers l’infini.

(2) *De plus,*

$$x = \sum_{\mathbf{k} \in \mathbb{N}^d} x_{\mathbf{k}} \prod_{j=1}^d (1 - V_j)^{[k_j]} \in F^r SA \quad \text{si et seulement si } x_{\mathbf{k}} \in F^{r-|\mathbf{k}|} A \text{ pour tout } \mathbf{k}.$$

On définit les anneaux suivants :

- $\mathbb{E}_R^{PD} = SA$ (resp. $\mathbb{E}_R^{[u,v]}$) pour $S = R_{\text{cris}}^+$ (resp. $R^{[u,v]}$) et $A = \mathbb{A}_{\text{cris}}(R)$ (resp. $\mathbb{A}_R^{[u,v]}$).
- $\mathbb{E}_{R_\infty}^{PD} = SA$ (resp. $\mathbb{E}_{R_\infty}^{[u,v]}$) pour $S = R_{\text{cris}}^+$ (resp. $R^{[u,v]}$) et $A = \mathbb{A}_{\text{cris}}(R_\infty)$ (resp. $\mathbb{A}_{R_\infty}^{[u,v]}$).
- $\mathbb{E}_{\bar{R}}^{PD} = SA$ (resp. $\mathbb{E}_{\bar{R}}^{[u,v]}$) pour $S = R_{\text{cris}}^+$ (resp. $R^{[u,v]}$) et $A = \mathbb{A}_{\text{cris}}(\bar{R})$ (resp. $\mathbb{A}_{\bar{R}}^{[u,v]}$).

On déduit de la proposition 7.1 les inclusions $\mathbb{E}_R^{PD} \subseteq \mathbb{E}_{R_\infty}^{PD} \subseteq \mathbb{E}_{\bar{R}}^{PD}$ (et de même avec l’exposant $[u, v]$).

On peut maintenant étendre les actions de G_R et de φ à ces anneaux :

Proposition 7.2 [Colmez et Nizioł 2017, Lemma 2.40]. Si $SA = \mathbb{E}_M^{PD}$ (respectivement $\mathbb{E}_M^{[u,v]}$) pour $M \in \{R, R_\infty, \bar{R}\}$, on note $SA' = \mathbb{E}_M^{PD}$ (respectivement $\mathbb{E}_M^{[u,v/p]}$). Alors :

- (1) φ s'étend de manière unique en un morphisme continu $SA \rightarrow SA'$.
- (2) L'action de G_R s'étend de manière unique à une action continue sur SA qui commute avec φ , et $\mathbb{E}_{R_\infty}^\star$ (pour $\star \in \{PD, [u, v]\}$) est l'ensemble des points fixes de \mathbb{E}_R^\star par le sous-groupe $\Gamma_R \subseteq G_R$.

7A2. Lemmes de Poincaré. On considère maintenant le complexe

$$F^r \Omega_{SA/A}^\bullet := F^r SA \rightarrow F^{r-1} SA \otimes_{SA} \Omega_{SA/A}^1 \rightarrow F^{r-2} SA \otimes_{SA} \Omega_{SA/A}^2 \rightarrow \dots$$

Proposition 7.3 [Colmez et Nizioł 2017, Lemma 2.37]. Le morphisme $F^r A \rightarrow F^r \Omega_{SA/A}^\bullet$ est un quasi-isomorphisme.

Démonstration. La preuve est identique à celle de Colmez et Nizioł. □

Pour simplifier les notations, on note $R_1 := R^{[u,v]}$ et $R_2 := \mathbb{A}_R^{[u,v]}$. On a des plongements $\iota_i : R^{[u,v]} \rightarrow R_i$ pour $i \in \{1, 2\}$. On note ensuite R_3 la log-PD-enveloppe complétée de $R_1 \otimes_{\mathbb{A}^{[u,v]}} R_2$ pour $\iota_2 \circ \iota_1^{-1} : R_1 \rightarrow R_2$ (et donc $R_3 = \mathbb{E}_R^{[u,v]}$). On pose $X_{ij} := \iota_i(X_j)$ pour $i \in \{1, 2\}$ et $j \in \{1, \dots, d\}$. Soient

$$\Omega_i^1 = \bigoplus_{j=1}^d \mathbb{Z} \frac{dX_{ij}}{X_{ij}}, \quad \Omega_3^1 = \Omega_1^1 \oplus \Omega_2^1, \quad \Omega_i^n = \bigwedge_{j=1}^n \Omega_i^1,$$

et

$$F^r \Omega_{R_i}^\bullet := F^r R_i \rightarrow F^{r-1} R_i \otimes_{\mathbb{Z}} \Omega_i^1 \rightarrow F^{r-2} R_i \otimes_{\mathbb{Z}} \Omega_i^2 \rightarrow \dots$$

Lemme 7.4 [Colmez et Nizioł 2017, Lemma 3.11]. Les applications $F^r \Omega_{R_1}^\bullet \rightarrow F^r \Omega_{R_3}^\bullet$ et $F^r \Omega_{R_2}^\bullet \rightarrow F^r \Omega_{R_3}^\bullet$ sont des quasi-isomorphismes.

7B. Application de Fontaine–Messing. On note $\mathbb{E}_{\bar{R},n}^{PD}$ la réduction modulo p^n de $\mathbb{E}_{\bar{R}}^{PD}$, et alors $\mathbb{E}_{\bar{R},n}^{PD}$ est la log-PD-enveloppe de $\text{Spec}(\bar{R}_n) \rightarrow \text{Spec}(\mathbb{A}_{\text{cris}}(\bar{R})_n \otimes_{\mathbb{A}_{\text{cris},n}} R_{\text{cris}}^+)$.

On a le diagramme commutatif suivant :

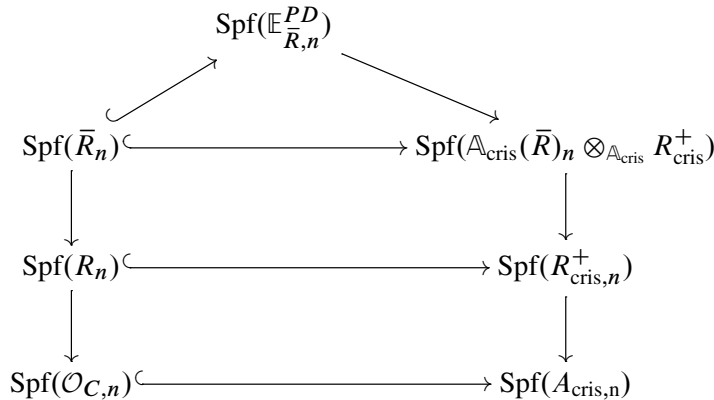

On définit le complexe syntomique $\text{Syn}(\bar{R}, r)_n := [F^r \Omega_{\mathbb{E}_{\bar{R},n}^{PD}}^\bullet \xrightarrow{p^r - \varphi} \Omega_{\mathbb{E}_{\bar{R},n}^{PD}}^\bullet]$.

La suite p^r -exacte

$$0 \rightarrow \mathbb{Z}/p^n(r)' \rightarrow F^r \mathbb{A}_{\text{cris}}(\bar{R})_n \xrightarrow{p^r - \varphi} \mathbb{A}_{\text{cris}}(\bar{R})_n \rightarrow 0$$

donne un p^r -quasi-isomorphisme

$$R\Gamma(G_R, \mathbb{Z}/p^n(r)') \xrightarrow{\sim} R\Gamma(G_R, [F^r \mathbb{A}_{\text{cris}}(\bar{R})_n \xrightarrow{p^r - \varphi} \mathbb{A}_{\text{cris}}(\bar{R})_n])$$

et, par la [proposition 7.3](#), on a

$$R\Gamma(G_R, [F^r \mathbb{A}_{\text{cris}}(\bar{R})_n \xrightarrow{p^r - \varphi} \mathbb{A}_{\text{cris}}(\bar{R})_n]) \xrightarrow{\sim} R\Gamma(G_R, [F^r \Omega_{\mathbb{E}_{\bar{R},n}^{PD}}^\bullet \xrightarrow{p^r - \varphi} \Omega_{\mathbb{E}_{\bar{R},n}^{PD}}^\bullet]).$$

On peut alors définir l'application de Fontaine–Messing

$$\alpha_{r,n}^{\text{FM}} : \text{Syn}(R, r)_n \rightarrow R\Gamma(G_R, \mathbb{Z}/p^n(r)').$$

On dit que deux morphismes f et g sont p^N -égaux (avec N une constante) si le morphisme induit par $f - g$ sur les groupes de cohomologie est tué par p^N . On obtient la version géométrique du théorème 4.16 de [\[Colmez et Nizioł 2017\]](#).

Théorème 7.5. *Il existe une constante N qui ne dépend que de p et de r telle que l'application de Fontaine–Messing α_r^{FM} (respectivement $\alpha_{r,n}^{\text{FM}}$) est p^N -égale à l'application α_r^0 (respectivement $\alpha_{r,n}^0$) donnée par le [théorème 6.4](#).*

Démonstration. On reprend les mêmes notations que dans [\[Colmez et Nizioł 2017, Theorem 4.16\]](#), c'est-à-dire :

- C_G et C_Γ désignent respectivement les complexes de cochaînes continues de G et de Γ .
- $K_\varphi(F^r S) := [F^r S \xrightarrow{p^r - \varphi} S']$ (et donc $K_\varphi(S) := [S \xrightarrow{1 - \varphi} S']$).
- $K_{\varphi,\partial}(F^r S) := \text{Kos}(\varphi, \partial, F^r S) = [\text{Kos}(\partial, F^r S) \xrightarrow{p^r - p^\bullet \varphi} \text{Kos}(\partial, S')]$.
- $K_{\varphi,\Gamma}(F^r S) := \text{Kos}(\varphi, \Gamma, F^r S) = [\text{Kos}(\Gamma, F^r S) \xrightarrow{p^r - \varphi} \text{Kos}(\Gamma, S')]$.
- $K_{\varphi,\Gamma,\partial}(F^r S) := [\text{Kos}(\Gamma, F^r \Omega_S^\bullet) \xrightarrow{p^r - \varphi} \text{Kos}(\Gamma, \Omega_{S'}^\bullet)]$.
- $K_{\varphi,\text{Lie}\Gamma}(F^r S) := [\text{Kos}(\text{Lie}\Gamma, F^r S) \xrightarrow{p^r - \varphi} \text{Kos}(\text{Lie}\Gamma, S')]$.
- $K_{\varphi,\text{Lie}\Gamma,\partial}(F^r S) := [\text{Kos}(\text{Lie}\Gamma, F^r \Omega_S^\bullet) \xrightarrow{p^r - \varphi} \text{Kos}(\text{Lie}\Gamma, \Omega_{S'}^\bullet)]$.

Le théorème se déduit alors du diagramme commutatif

$$\begin{array}{ccccccc}
 K_{\varphi, \partial}(F^r R_{\text{cris}}^+) & \longrightarrow & C_G(K_{\varphi, \partial}(F^r \mathbb{E}_{\bar{R}}^{PD})) & \xleftarrow{\sim} & C_G(K_{\varphi}(F^r \mathbb{A}_{\text{cris}}(\bar{R}))) & \xleftarrow{\sim} & C_G(\mathbb{Z}_p(r)) \\
 \downarrow \tau_{\leq r} \wr & & \downarrow & & \downarrow & \swarrow (22) & \downarrow (15) \wr \\
 K_{\varphi, \partial}(F^r R^{[u, v]}) & \longrightarrow & C_G(K_{\varphi, \partial}(F^r \mathbb{E}_{\bar{R}}^{[u, v]})) & \xleftarrow{\sim} & C_G(K_{\varphi}(F^r \mathbb{A}_{\bar{R}}^{[u, v]})) & \xleftarrow{t^r} & C_G(K_{\varphi}(\mathbb{A}_{\bar{R}}^{(0, v]^+}(r))) \longrightarrow C_G(K_{\varphi}(\mathbb{A}_{\bar{R}}(r))) \\
 & & \uparrow \mu_H & & \uparrow \mu_H & & \uparrow \mu_H \wr \text{proposition 6.2} \\
 C_{\Gamma}(K_{\varphi, \partial}(F^r \mathbb{E}_{R_{\infty}}^{[u, v]})) & \xleftarrow{\sim} & C_{\Gamma}(K_{\varphi}(F^r \mathbb{A}_{R_{\infty}}^{[u, v]})) & \xleftarrow{t^r} & C_{\Gamma}(K_{\varphi}(\mathbb{A}_{R_{\infty}}^{(0, v]^+}(r))) & \longrightarrow & C_{\Gamma}(K_{\varphi}(\mathbb{A}_{R_{\infty}}(r))) \\
 & & \uparrow \mu_{\infty} & & \uparrow \mu_{\infty} & & \uparrow \mu_{\infty} \wr \text{proposition 6.3} \\
 C_{\Gamma}(K_{\varphi, \partial}(F^r \mathbb{E}_R^{[u, v]})) & \xleftarrow{\sim} & C_{\Gamma}(K_{\varphi}(F^r \mathbb{A}_R^{[u, v]})) & \xleftarrow{t^r} & C_{\Gamma}(K_{\varphi}(\mathbb{A}_R^{(0, v]^+}(r))) & \longrightarrow & C_{\Gamma}(K_{\varphi}(\mathbb{A}_R(r))) \\
 & & \wr & & \wr & & \wr \\
 K_{\varphi, \Gamma, \partial}(F^r \mathbb{E}_R^{[u, v]}) & \xleftarrow{\sim} & K_{\varphi, \Gamma}(F^r \mathbb{A}_R^{[u, v]}) & \xleftarrow{t^r} & K_{\varphi, \Gamma}(\mathbb{A}_R^{(0, v]^+}(r)) & \xrightarrow{\sim} & K_{\varphi, \Gamma}(\mathbb{A}_R(r)) \\
 & & \wr & & \wr & & \wr \\
 K_{\varphi, \text{Lie } \Gamma, \partial}(F^r \mathbb{E}_R^{[u, v]}) & \xleftarrow{\sim} & K_{\varphi, \text{Lie } \Gamma}(F^r \mathbb{A}_R^{[u, v]}) & \xleftarrow{\sim} & K_{\varphi, \text{Lie } \Gamma}(\mathbb{A}_R^{[u, v]}(r)) & & \\
 & & \wr & & \wr & & \wr \\
 & & \uparrow t^{\bullet} & & \uparrow t^{\bullet}, \tau_{\leq r}, 5.6 & & \\
 K_{\varphi, \partial}(F^r \mathbb{E}_R^{[u, v]}) & \xleftarrow{\sim} & K_{\varphi, \partial}(F^r \mathbb{A}_R^{[u, v]}) & & & & \\
 \text{lemme 7.4} \wr & & & & & &
 \end{array}$$

Les flèches horizontales de la quatrième colonne vers la troisième sont données par les compositions d'applications

$$\begin{array}{ccc}
 \text{Kos}(\Gamma_R, S(r)) \xrightarrow{1-\varphi} \text{Kos}(\Gamma_R, S'(r)) & & \text{Kos}(\text{Lie } \Gamma_R, S(r)) \xrightarrow{1-\varphi} \text{Kos}(\text{Lie } \Gamma_R, S'(r)) \\
 \downarrow & & \downarrow \\
 \text{Kos}(\Gamma_R, S(r)) \xrightarrow{p^r(1-\varphi)} \text{Kos}(\Gamma_R, S'(r)) & \text{et} & \text{Kos}(\text{Lie } \Gamma_R, S(r)) \xrightarrow{p^r(1-\varphi)} \text{Kos}(\text{Lie } \Gamma_R, S'(r)) \\
 \downarrow t^r & & \downarrow t^r \\
 \text{Kos}(\Gamma_R, F^r S) \xrightarrow{p^r-\varphi} \text{Kos}(\Gamma_R, S') & & \text{Kos}(\text{Lie } \Gamma_R, F^r S) \xrightarrow{p^r-\varphi} \text{Kos}(\text{Lie } \Gamma_R, S')
 \end{array}$$

Le passage de la troisième à la quatrième ligne se fait en utilisant le quasi-isomorphisme entre les complexes de Koszul et la cohomologie de groupe. □

8. Résultat global

À partir de maintenant, on se place dans le cas où il n’y a plus de diviseur à l’infini. Plus précisément, on suppose que localement \mathfrak{X} s’écrit $\mathrm{Spf}(R_0)$ avec $R_0^\square \rightarrow R_0$ la complétion d’un morphisme étale et

$$R_0^\square := \mathcal{O}_K \left\{ X_1, \dots, X_d, \frac{1}{X_1 \cdots X_a}, \frac{\varpi}{X_{a+1} \cdots X_d} \right\}$$

(pour $a, d \in \mathbb{N}$). On suppose $\mathrm{Spf}(R_0)$ connexe. On rappelle que $\mathrm{Spf}(\mathcal{O}_K)$ est muni de la log-structure donnée par son point fermé et \mathfrak{X} de celle donnée par $\mathcal{O}_{\mathfrak{X}} \cap (\mathcal{O}_{\mathfrak{X}}[1/p])^\times \hookrightarrow \mathcal{O}_{\mathfrak{X}}$.

Le but de cette section est de montrer le théorème suivant :

Théorème 8.1. *Les applications locales du théorème 6.4 se globalisent en des morphismes*

$$\begin{aligned} \alpha_r^0 &: \tau_{\leq r} R\Gamma_{\mathrm{syn}}(\mathfrak{X}_{\mathcal{O}_C}, r) \rightarrow \tau_{\leq r} R\Gamma_{\mathrm{ét}}(\mathfrak{X}_C, \mathbb{Z}_p(r)'), \\ \alpha_{r,n}^0 &: \tau_{\leq r} R\Gamma_{\mathrm{syn}}(\mathfrak{X}_{\mathcal{O}_C}, r)_n \rightarrow \tau_{\leq r} R\Gamma_{\mathrm{ét}}(\mathfrak{X}_C, \mathbb{Z}/p^n\mathbb{Z}(r)'). \end{aligned}$$

De plus, ces morphismes sont des p^{Nr} -isomorphismes pour une constante N universelle.

En particulier, on a le résultat suivant ([Colmez et Nizioł 2017, Corollary 5.12]) :

Corollaire 8.2. *Si \mathfrak{X} est un log-schéma formel propre à réduction semi-stable sur \mathcal{O}_K , alors pour $k \leq r$, le p^{Nr} -isomorphisme ci-dessus induit un isomorphisme*

$$\alpha_{r,k}^0 : H_{\mathrm{syn}}^k(\mathfrak{X}_{\mathcal{O}_C}, r)_{\mathbb{Q}} \xrightarrow{\sim} H_{\mathrm{ét}}^k(\mathfrak{X}_C, \mathbb{Q}_p(r)).$$

Démonstration. Par définition de la limite homotopique, si A^\bullet désigne le complexe $R\Gamma_{\mathrm{syn}}(\mathfrak{X}_{\mathcal{O}_C}, r)$ (respectivement $R\Gamma_{\mathrm{ét}}(\mathfrak{X}_C, \mathbb{Q}_p(r))$) et A_n^\bullet sa réduction modulo p^n (respectivement $R\Gamma_{\mathrm{ét}}(\mathfrak{X}_C, \mathbb{Z}/p^n\mathbb{Z}(r)')$), alors on a un triangle distingué

$$A^\bullet \rightarrow \prod_n A_n^\bullet \rightarrow \prod_n A_n^\bullet \rightarrow A^\bullet[1]$$

où l’application $\prod_n A_n^\bullet \rightarrow \prod_n A_n^\bullet$ est donnée par $(k_n) \mapsto (k_n - \psi_{n+1}(k_{n+1}))$ (où $\psi_{n+1} : A_{n+1}^\bullet \rightarrow A_n^\bullet$ sont les morphismes associés au système projectif (A_n^\bullet)).

Par le théorème 8.1, pour tout n et $k \leq r$, on a un p^{Nr} -isomorphisme $H^k R\Gamma_{\mathrm{syn}}(\mathfrak{X}_{\mathcal{O}_C}, r)_n \xrightarrow{\sim} H^k R\Gamma_{\mathrm{ét}}(\mathfrak{X}_C, \mathbb{Z}/p^n\mathbb{Z}(r)').$ En écrivant la suite exacte longue associée au triangle distingué ci-dessus, on obtient un diagramme commutatif

$$\begin{array}{ccccccc} \cdots & \longrightarrow & \prod_n H_{\mathrm{syn}}^{k-1}(r)_n & \longrightarrow & H_{\mathrm{syn}}^k(r) & \longrightarrow & \prod_n H_{\mathrm{syn}}^k(r)_n \longrightarrow \cdots \\ & & \downarrow \wr & & \downarrow & & \downarrow \wr \\ \cdots & \longrightarrow & \prod_n H_{\mathrm{ét}}^{k-1}(r)_n & \longrightarrow & H_{\mathrm{ét}}^k(r) & \longrightarrow & \prod_n H_{\mathrm{ét}}^k(r)_n \longrightarrow \cdots \end{array}$$

où pour simplifier on a noté $H_{\text{syn}}^k(r)_n := H^k R\Gamma_{\text{syn}}(\mathfrak{X}_{\mathcal{O}_C}, r)_n$, $H_{\text{syn}}^k(r) := H^k R\Gamma_{\text{syn}}(\mathfrak{X}_{\mathcal{O}_C}, r)$ et de même pour la cohomologie étale. On tensorise ensuite par \mathbb{Q}_p pour obtenir, pour tout $k \leq r$, un isomorphisme

$$\alpha_{r,k}^0 : H_{\text{syn}}^k(\mathfrak{X}_{\mathcal{O}_C}, r)_{\mathbb{Q}} \xrightarrow{\sim} H_{\text{ét}}^k(\mathfrak{X}_C, \mathbb{Q}_p(r)). \quad \square$$

Remarque 8.3. Dans [Tsuji 1999], pour obtenir un morphisme compatible avec les applications symboles, une normalisation par un facteur p^{-r} est nécessaire (voir (3.1.12) et la proposition 3.2.4 (3) de cet article pour la compatibilité avec les applications symboles). Cette normalisation n'apparaît pas ici car le morphisme au niveau entier qu'on utilise n'est pas exactement égal à celui de Tsuji, mais est obtenu en tordant celui-ci par un facteur p^r .

Revenons à la preuve du [théorème 8.1](#). On a construit le morphisme α_r^0 localement, il suffit de montrer qu'on peut le globaliser. Pour cela on utilise la méthode de Česnavičius et Koshikawa [2019, §5] (qui généralise celle de [Bhatt et al. 2018]).

On se place dans le cas où $\mathfrak{X}_{\mathcal{O}_C} = \text{Spf}(R)$. On suppose que les intersections de deux composants irréductibles de la fibre spéciale $\text{Spec}(R \otimes_{\mathcal{O}_C} k)$ sont non vides (en particulier, $\text{Spf}(R)$ est connexe) et qu'il existe une immersion fermée

$$\mathfrak{X}_{\mathcal{O}_C} \rightarrow \text{Spf}(R_{\Sigma}^{\square}) \times_{\mathcal{O}_C} \prod_{\lambda \in \Lambda} \text{Spf} R_{\lambda}^{\square} \quad (27)$$

telle que :

- (i) $R_{\Sigma}^{\square} := \mathcal{O}_C\{X_{\sigma}^{\pm 1} \mid \sigma \in \Sigma\}$ avec Σ un ensemble fini.
- (ii) $R_{\lambda}^{\square} := \mathcal{O}_C\{X_{\lambda,1}, \dots, X_{\lambda,d}, 1/(X_{\lambda,1} \cdots X_{\lambda,a_{\lambda}}), \varpi/(X_{\lambda,a_{\lambda}+1} \cdots X_{\lambda,d})\}$ où $\lambda \in \Lambda$ avec Λ fini.
- (iii) $\text{Spf}(R) \rightarrow \text{Spf}(R_{\Sigma}^{\square})$ est une immersion fermée.
- (iv) $\text{Spf}(R) \rightarrow \text{Spf}(R_{\lambda}^{\square})$ est étale pour tout λ dans Λ .

En particulier, pour tout λ dans Λ , chaque composante irréductible de la fibre spéciale $\text{Spec}(R \otimes k)$ est donnée par un unique $(t_{\lambda,i})$ pour $a_{\lambda} + 1 \leq i \leq d$.

On choisit des éléments $\{u_{\sigma}\}_{\sigma \in \Sigma}$ (respectivement $\{u_{\lambda,i}\}_{1 \leq i \leq d}$ avec $\lambda \in \Lambda$) tels qu'on ait une application $X_{\sigma} \mapsto u_{\sigma}$ de R_{Σ}^{\square} dans R (respectivement $X_{\lambda,i} \mapsto u_{\lambda,i}$ de R_{λ}^{\square} dans R).

Dans la suite on note $\text{Spf}(R_{\Sigma, \Lambda}^{\square})$ le produit $\text{Spf}(R_{\Sigma}^{\square}) \times_{\mathcal{O}_C} \prod_{\lambda \in \Lambda} \text{Spf}(R_{\lambda}^{\square})$.

Comme dans la [section 2B2](#), on munit chaque $\text{Spf}(R_{\lambda}^{\square})$ de la log-structure donnée par la fibre spéciale et on munit $\text{Spf}(R_{\Sigma, \Lambda}^{\square})$ et $\text{Spf}(R)$ des log-structures induites.

Remarque 8.4. On peut toujours trouver une base de $\mathfrak{X}_{\text{ét}}$ telle qu'on ait de telles immersions. Soit x un point de \mathfrak{X} . Si x est dans le lieu lisse de \mathfrak{X} alors localement $\mathfrak{X}_{\mathcal{O}_C}$ s'écrit $\text{Spf}(\hat{A})$ avec A de type fini sur \mathcal{O}_C et donc il existe une immersion fermée $\text{Spec}(A) \hookrightarrow \text{Spec}(\mathcal{O}_C[X_1, \dots, X_n])$. On recouvre ensuite $\text{Spec}(\mathcal{O}_C[X_1, \dots, X_n])$ par une union de tores et on obtient que localement $\mathfrak{X}_{\mathcal{O}_C}$ s'écrit $\text{Spf}(R)$ tel qu'il existe une immersion fermée $\text{Spf}(R) \hookrightarrow \text{Spf}(R_{\Sigma}^{\square})$ avec Σ un ensemble fini.

Si maintenant x n'est plus dans le lieu lisse de \mathfrak{X} , alors $\mathfrak{X}_{\mathcal{O}_C}$ s'écrit localement $\mathrm{Spf}(R_\lambda)$ pour une \mathcal{O}_C -algèbre R_λ telle qu'on ait une application étale $R_\lambda^\square \rightarrow R_\lambda$ avec

$$R_\lambda^\square := \mathcal{O}_C \left\{ X_{\lambda,1}, \dots, X_{\lambda,d}, \frac{1}{X_{\lambda,1} \cdots X_{\lambda,a_\lambda}}, \frac{\varpi}{X_{\lambda,a_\lambda+1} \cdots X_{\lambda,d}} \right\}$$

et telle que x est donné par $(X_{\lambda,a_\lambda+1} \cdots X_{\lambda,d})$. Si on localise en x , on obtient une immersion fermée dans un tore formel $\mathrm{Spf}(R_{\frac{\square}{\Sigma}})$.

Remarque 8.5. (1) Pour un tel R , si $R_{\Sigma_1, \Lambda_1}^\square$ et $R_{\Sigma_2, \Lambda_2}^\square$ vérifient les conditions ci-dessus avec $\Sigma_1 \subseteq \Sigma_2$ et $\Lambda_1 \subseteq \Lambda_2$, on note $f_1^2 : R_{\Sigma_1, \Lambda_1}^\square \rightarrow R_{\Sigma_2, \Lambda_2}^\square$ l'application induite par $X_\sigma \mapsto X_\sigma$ et $X_{\lambda,i} \mapsto X_{\lambda,i}$ pour σ dans Σ_1 , λ dans Λ_1 et i dans $\{1, \dots, d\}$. L'ensemble des $R_{\Sigma, \Lambda}^\square$ muni des applications ainsi définies forme alors un système inductif filtrant. Il est inductif, car si $\Sigma_1 \subseteq \Sigma_2 \subseteq \Sigma_3$ et $\Lambda_1 \subseteq \Lambda_2 \subseteq \Lambda_3$, on a $f_1^3 = f_2^3 \circ f_1^2$. Vérifions qu'il est filtrant. Par définition du système, pour $\Sigma_1 \subseteq \Sigma_2$ et $\Lambda_1 \subseteq \Lambda_2$, f_1^2 est la seule application de $R_{\Sigma_1, \Lambda_1}^\square$ dans $R_{\Sigma_2, \Lambda_2}^\square$. Considérons à présent deux anneaux $R_{\Sigma_1, \Lambda_1}^\square$ et $R_{\Sigma_2, \Lambda_2}^\square$ vérifiant (27) pour R . On note $\Sigma_3 := \Sigma_1 \sqcup \Sigma_2$ et $\Lambda_3 = \Lambda_1 \sqcup \Lambda_2$. Alors (Σ_3, Λ_3) vérifie les conditions (27) pour R et les deux morphismes f_1^3 et f_2^3 sont bien définis.

(2) Maintenant si $f : R \rightarrow R'$ est un morphisme étale tel qu'on ait une immersion fermée $\mathrm{Spf}(R') \rightarrow \mathrm{Spf}(R_{\Sigma', \Lambda'}^\square)$, on note $\tilde{\Sigma} := \Sigma \sqcup \Sigma'$ et $\tilde{\Lambda} = \Lambda \sqcup \Lambda'$. Alors $(\tilde{\Sigma}, \tilde{\Lambda})$ vérifie les conditions (27) pour R' : comme $R \rightarrow R'$ est étale, $R_\lambda^\square \rightarrow R'$ est étale pour tout λ de $\tilde{\Lambda}$. On a de plus une surjection $R_{\tilde{\Sigma}}^\square \rightarrow R'$ donnée par

$$\begin{cases} X_\sigma \mapsto f(u_\sigma) & \text{pour } \sigma \in \Sigma, \\ X_{\sigma'} \mapsto u_{\sigma'} & \text{pour } \sigma' \in \Sigma', \end{cases}$$

et telle qu'on ait un diagramme commutatif

$$\begin{array}{ccc} R & \xrightarrow{f} & R' \\ \uparrow & & \uparrow \\ R_{\Sigma'}^\square & \longrightarrow & R_{\tilde{\Sigma}}^\square \end{array}$$

On obtient alors un morphisme de $R_{\Sigma, \Lambda}^\square \rightarrow R_{\tilde{\Sigma}, \tilde{\Lambda}}^\square$ et de $\varinjlim_{(\Sigma, \Lambda)} R_{\Sigma, \Lambda}^\square \rightarrow \varinjlim_{(\Sigma', \Lambda')} R_{\Sigma', \Lambda'}^\square$ (où la première limite est prise sur l'ensemble des (Σ, Λ) qui vérifient (27) pour R , et la seconde limite sur l'ensemble des (Σ', Λ') qui vérifient (27) pour R').

8A. Construction du quasi-isomorphisme $\alpha_{r, \Sigma, \Lambda}$. On travaille localement. Supposons que $\mathfrak{X}_{\mathcal{O}_C} = \mathrm{Spf}(R)$ avec R tel qu'il existe des immersions comme en (27).

On va définir un anneau $R_{\Sigma, \Lambda}^{\mathrm{PD}}$ en suivant la construction de [Česnavičius et Koshikawa 2019, § 5.22]. Notons $\mathrm{Spf}(\mathbb{A}_{\mathrm{inf}}(R_{\Sigma, \Lambda}^\square))$ le produit des

$$\mathrm{Spf}(\mathbb{A}_{\mathrm{inf}}(R_\lambda^\square)) := \mathrm{Spf} \left(\mathbb{A}_{\mathrm{inf}} \left\{ X_{\lambda,1}, \dots, X_{\lambda,d}, \frac{1}{X_{\lambda,1} \cdots X_{\lambda,a_\lambda}}, \frac{[\varpi^b]}{X_{\lambda,a_\lambda+1} \cdots X_{\lambda,d}} \right\} \right)$$

et de $\mathrm{Spf}(\mathbb{A}_{\mathrm{inf}}(R_{\Sigma}^{\square})) := \mathrm{Spf}(\mathbb{A}_{\mathrm{inf}}\{X_{\sigma}^{\pm 1} \mid \sigma \in \Sigma\})$. Comme précédemment, $\mathbb{A}_{\mathrm{inf}}$ est muni de la log-structure induite par $x \mapsto [x]$ de $\mathcal{O}^b \setminus \{0\} \rightarrow \mathbb{A}_{\mathrm{inf}}$. Les $\mathrm{Spf}(\mathbb{A}_{\mathrm{inf}}(R_{\lambda}^{\square}))$ sont munis de la log-structure associée à

$$\mathbb{N}^{d-a_{\lambda}} \sqcup_{\mathbb{N}} (\mathcal{O}^b \setminus \{0\}) \rightarrow \mathbb{A}_{\mathrm{inf}}(R_{\Sigma, \Lambda}^{\square})$$

qui envoie (n_i) sur $\prod_{a_{\lambda}+1 \leq i \leq d} X_i^{n_i}$ et $x \in \mathcal{O}^b$ sur $[x] \in \mathbb{A}_{\mathrm{inf}}$, le morphisme $\mathbb{N} \rightarrow \mathbb{N}^{d-a_{\lambda}}$ est l'application diagonale et $\mathbb{N} \rightarrow \mathcal{O}^b \setminus \{0\}$ est donnée par $m \mapsto [x^b]^m$. Comme dans la [remarque 2.3](#), on peut se ramener à des log-structures fines par changement de base [[Česnavičius et Koshikawa 2019](#), §5.9] et de cette façon $\mathbb{A}_{\mathrm{inf}}(R_{\Sigma, \Lambda}^{\square})$ est log-lisse sur $\mathbb{A}_{\mathrm{inf}}$.

On a une immersion fermée

$$\mathrm{Spec}(R/p) \hookrightarrow \mathrm{Spf}(\mathbb{A}_{\mathrm{inf}}(R_{\Sigma, \Lambda}^{\square}))$$

et pour $m, n \geq 1$, on peut construire une log-PD-enveloppe [[Česnavičius et Koshikawa 2019](#), §5.22; [Beilinson 2013](#), §1.3] :

$$\begin{array}{ccc} & \mathrm{Spec}(R_{\Sigma, \Lambda, n, m}^{\mathrm{PD}}) & \\ & \nearrow & \searrow \\ \mathrm{Spec}(R/p) & \longrightarrow & \mathrm{Spec}(\mathbb{A}_{\mathrm{inf}}(R_{\Sigma, \Lambda}^{\square})/(p^n, \xi^m)) \end{array}$$

En fait, pour m suffisamment grand (tel que $\xi^m \in p^n \mathbb{A}_{\mathrm{cris}}$), $R_{\Sigma, \Lambda, n, m}^{\mathrm{PD}}$ s'identifie à la log-PD-enveloppe de

$$\mathrm{Spec}(R/p) \hookrightarrow \mathrm{Spec}(\mathbb{A}_{\mathrm{cris}}(R_{\Sigma, \Lambda}^{\square})/p^n) \quad \text{sur} \quad \mathrm{Spec}(\mathcal{O}_C/p) \hookrightarrow \mathrm{Spec}(\mathbb{A}_{\mathrm{cris}}/p^n).$$

Notons $R_{\Sigma, \Lambda, n}^{\mathrm{PD}}$ cette log-PD-enveloppe (indépendante de m). On a $R_{\Sigma, \Lambda, n}^{\mathrm{PD}}/p^{n-1} = R_{\Sigma, \Lambda, n-1}^{\mathrm{PD}}$ et on obtient un schéma formel p -adique $\mathrm{Spf}(R_{\Sigma, \Lambda}^{\mathrm{PD}})$ tel qu'on ait une factorisation

$$\begin{array}{ccc} & \mathrm{Spf}(R_{\Sigma, \Lambda}^{\mathrm{PD}}) & \\ & \nearrow & \searrow \\ \mathrm{Spec}(R/p) & \longrightarrow & \mathrm{Spf}(\mathbb{A}_{\mathrm{cris}}(R_{\Sigma, \Lambda}^{\square})) \end{array}$$

où $\mathbb{A}_{\mathrm{cris}}(R_{\Sigma, \Lambda}^{\square}) := \mathbb{A}_{\mathrm{cris}} \widehat{\otimes}_{\mathbb{A}_{\mathrm{inf}}} \mathbb{A}_{\mathrm{inf}}(R_{\Sigma, \Lambda}^{\square})$ (le produit tensoriel est complété pour la topologie p -adique).

On a un morphisme de Frobenius sur $R_{\Sigma, \Lambda}^{\mathrm{PD}}$ venant de celui de R/p . On étend de même les applications différentielles $\partial_{\sigma} = d/(d \log(X_{\sigma}))$ et $\partial_{\lambda, i} = d/(d \log(X_{\lambda, i}))$ à $R_{\Sigma, \Lambda}^{\mathrm{PD}}$. On a de plus une factorisation

$$\mathrm{Spec}(R/p) \hookrightarrow \mathrm{Spf}(R) \hookrightarrow \mathrm{Spf}(R_{\Sigma, \Lambda}^{\mathrm{PD}}).$$

Le but de cette partie est de construire un p^{Nr} -quasi-isomorphisme

$$\alpha_{r, \Sigma, \Lambda} : \tau_{\leq r} \mathrm{Kos}(\varphi, \partial, F^r R_{\Sigma, \Lambda}^{\mathrm{PD}}) \rightarrow \tau_{\leq r} R\Gamma(G_R, \mathbb{Z}_p(r))$$

avec N qui ne dépend ni de Σ , Λ , ni de R .

On considère les anneaux

$$R_{\Sigma,\Lambda}^{[u]} = \mathbb{A}^{[u]} \widehat{\otimes}_{\mathbb{A}_{\text{cris}}} R_{\Sigma,\Lambda}^{PD}, \quad R_{\Sigma,\Lambda}^{[u,v]} = \mathbb{A}^{[u,v]} \widehat{\otimes}_{\mathbb{A}_{\text{cris}}} R_{\Sigma,\Lambda}^{PD}, \quad R_{\Sigma,\Lambda}^{(0,v)^+} = \mathbb{A}^{(0,v)^+} \widehat{\otimes}_{\mathbb{A}_{\text{cris}}} R_{\Sigma,\Lambda}^{PD}$$

où les produits tensoriels sont complétés pour la topologie p -adique.

L'application $R_{\Sigma,\Lambda}^{PD} \rightarrow R_{\Sigma,\Lambda}^{[u,v]}$ induit alors un morphisme sur les complexes de Koszul

$$\text{Kos}(\varphi, \partial, F^r R_{\Sigma,\Lambda}^{PD}) \rightarrow \text{Kos}(\varphi, \partial, F^r R_{\Sigma,\Lambda}^{[u,v]}). \tag{28}$$

Soient $R_{\Sigma,\infty}^{\square}$ et $R_{\lambda,\infty}^{\square}$ les complétions p -adiques des anneaux

$$\varinjlim_n \mathcal{O}_C \{ X_{\sigma}^{\pm 1/p^n} \mid \sigma \in \Sigma \} \quad \text{et} \quad \varinjlim_n \mathcal{O}_C \left\{ X_{\lambda,1}^{1/p^n}, \dots, X_{\lambda,d}^{1/p^n}, \frac{1}{(X_{\lambda,1} \cdots X_{\lambda,a_{\lambda}})^{1/p^n}}, \frac{\varpi^{1/p^n}}{(X_{\lambda,a_{\lambda}+1} \cdots X_{\lambda,d})^{1/p^n}} \right\}.$$

On note $R_{\Sigma,\Lambda,\infty}^{\square}$ le produit tensoriel des anneaux précédents, $R_{\Sigma,\Lambda,\infty} := R_{\Sigma,\Lambda,\infty}^{\square} \widehat{\otimes}_{R_{\Sigma,\Lambda}^{\square}} R$, et on note $\mathbb{A}_{\text{cris}}(R_{\Sigma,\Lambda,\infty})$, $\mathbb{A}_{R_{\Sigma,\Lambda,\infty}}^{[u,v]}$, $\mathbb{A}_{R_{\Sigma,\Lambda,\infty}}^{[u]}$ les anneaux associés. Enfin, on considère les groupes

$$\Gamma_{\Sigma} := \text{Gal}\left(R_{\Sigma,\infty}^{\square} \left[\frac{1}{p} \right] / R_{\Sigma}^{\square} \left[\frac{1}{p} \right] \right) \cong \mathbb{Z}_p^{\Sigma}, \quad \Gamma_{\lambda} := \text{Gal}\left(R_{\lambda,\infty}^{\square} \left[\frac{1}{p} \right] / R_{\lambda}^{\square} \left[\frac{1}{p} \right] \right) \cong \mathbb{Z}_p^d,$$

et

$$\Gamma_{\Sigma,\Lambda} := \Gamma_{\Sigma} \times \prod_{\lambda \in \Lambda} \Gamma_{\lambda}.$$

Si $(\gamma_{\sigma})_{\sigma}$ et $(\gamma_{\lambda,i})_{1 \leq i \leq d}$ sont des générateurs topologiques de Γ_{Σ} et de Γ_{λ} , les actions de Γ_{Σ} et Γ_{λ} sur R_{Σ}^{\square} et R_{λ}^{\square} sont données par

$$\begin{aligned} \gamma_{\sigma}(X_{\sigma}) &= [\varepsilon]X_{\sigma} & \text{et} & & \gamma_{\sigma'}(X_{\sigma'}) &= X_{\sigma'} & \text{si } \sigma' \neq \sigma, \\ \gamma_{\lambda,i}(X_{\lambda,i}) &= [\varepsilon]X_{\lambda,i} & \text{et} & & \gamma_{\lambda,i}(X_{\lambda,j}) &= X_{\lambda,j} & \text{si } i \neq j. \end{aligned}$$

On en déduit une action de $\Gamma_{\Sigma,\Lambda}$ sur $R_{\Sigma,\Lambda}^{PD}$, $\mathbb{A}_{\Sigma,\Lambda}^{[u]}$, $\mathbb{A}_{\Sigma,\Lambda}^{[u,v]}$.

Enfin, pour $1 \leq i \leq |\Sigma| + d|\Lambda|$, on écrit $J_i := \{(j_1, \dots, j_i) \mid 1 \leq j_1 < \dots < j_i \leq |\Sigma| + d|\Lambda|\}$. Les mêmes preuves que celles des lemmes 5.6 et 5.8 donnent :

Proposition 8.6. *Il existe un p^{30r} -quasi-isomorphisme*

$$\begin{aligned} \tau_{\leq r} \text{Kos}(\varphi, \partial, F^r R_{\Sigma,\Lambda}^{[u,v]}) &\xrightarrow{t^{\bullet}} \tau_{\leq r} \text{Kos}(\varphi, \text{Lie } \Gamma_{\Sigma,\Lambda}, F^r R_{\Sigma,\Lambda}^{[u,v]}) \\ &\xleftarrow{t^r} \tau_{\leq r} \text{Kos}(\varphi, \text{Lie } \Gamma_{\Sigma,\Lambda}, R_{\Sigma,\Lambda}^{[u,v]}(r)) \xleftarrow{\beta} \tau_{\leq r} \text{Kos}(\varphi, \Gamma_{\Sigma,\Lambda}, R_{\Sigma,\Lambda}^{[u,v]}(r)). \end{aligned} \tag{29}$$

Remarque 8.7. Modulo p^n , on obtient de la même façon un p^{58r} -quasi-isomorphisme.

Le morphisme $R_{\Sigma,\Lambda}^{PD} \rightarrow \mathbb{A}_{\text{cris}}(R_{\Sigma,\Lambda,\infty})$ [Česnavičius et Koshikawa 2019, (5.38.1)] induit un morphisme

$$R\Gamma(\Gamma_{\Sigma,\Lambda}, R_{\Sigma,\Lambda}^{[u,v]}(r)) \rightarrow R\Gamma(\Gamma_{\Sigma,\Lambda}, A_{R_{\Sigma,\Lambda,\infty}}^{[u,v]}(r)). \tag{30}$$

On considère ensuite la flèche

$$R\Gamma(\Gamma_{\Sigma,\Lambda}, A_{R_{\Sigma,\Lambda,\infty}}^{[u,v]}(r)) \rightarrow R\Gamma_{\text{proét}}(R, \mathbb{A}_{\overline{R}}^{[u,v]}(r)) \tag{31}$$

induite par le morphisme de bord associé au toseur

$$\mathrm{Spf}(R_{\Sigma, \Lambda, \infty}) \rightarrow \mathrm{Spf}(R)$$

(voir [Stacks 2005–, tag 01GY; Česnavičius et Koshikawa 2019, (3.15.1)]), et par le lemme $K(\pi, 1)$ de Scholze, le terme de droite dans (31) est calculé par la cohomologie de Galois $R\Gamma(G_R, \mathbb{A}_{\bar{R}}^{[u, v]}(r))$.

On rappelle qu'on a également un quasi-isomorphisme

$$R\Gamma(G_R, \mathbb{Z}_p(r)) \cong [R\Gamma_{\mathrm{cont}}(G_R, F^r \mathbb{A}_{\bar{R}}^{[u, v]}) \xrightarrow{p^r - \varphi} R\Gamma(G_R, \mathbb{A}_{\bar{R}}^{[u, v]})]. \tag{32}$$

En composant les morphismes précédents, on obtient une application

$$\alpha_{r, \Sigma, \Lambda} : \tau_{\leq r} \mathrm{Kos}(\varphi, \partial, F^r R_{\Sigma, \Lambda}^{\mathrm{PD}}) \rightarrow \tau_{\leq r} R\Gamma(G_R, \mathbb{Z}_p(r)).$$

Proposition 8.8. *Il existe une constante N indépendante de R, Σ et Λ telle que l'application $\alpha_{r, \Sigma, \Lambda}$ ci-dessus est un p^{Nr} -quasi-isomorphisme.*

Démonstration. On fixe un λ dans Λ . On note

$$R_{\mathrm{cris}, \lambda, \square}^+ := \mathbb{A}_{\mathrm{cris}} \left\{ X_{\lambda, 1}, \dots, X_{\lambda, d}, \frac{1}{X_{\lambda, 1} \cdots X_{\lambda, a_\lambda}}, \frac{[\varpi^b]}{X_{\lambda, a_\lambda + 1} \cdots X_{\lambda, d}} \right\}$$

et $R_{\mathrm{cris}, \lambda, \square}^+ \rightarrow R_{\mathrm{cris}, \lambda}^+$ un relevé étale de $R_{\lambda, \square} \rightarrow R$. On construit les anneaux $R_{\lambda}^{[u, v]}$ et $\mathbb{A}_{R_{\infty, \lambda}}^{[u, v]}$ associés et on a alors (par ce qui a été fait plus haut) un p^{Nr} -quasi-isomorphisme

$$\alpha_{r, \lambda} : \tau_{\leq r} \mathrm{Kos}(\varphi, \partial, F^r R_{\mathrm{cris}, \lambda}^+) \xrightarrow{\sim} \tau_{\leq r} R\Gamma(G_R, \mathbb{Z}_p(r)).$$

On a un diagramme commutatif

$$\begin{array}{ccc} & \mathrm{Spf}(R_{\Sigma, \Lambda}^{\mathrm{PD}}) & \\ \nearrow & & \searrow \\ \mathrm{Spec}(R/p) & \longrightarrow & \mathrm{Spf}(\mathbb{A}_{\mathrm{cris}}(R_{\Sigma, \Lambda}^{\square})) \\ \downarrow & & \downarrow \\ \mathrm{Spf}(R_{\mathrm{cris}, \lambda}^+) & \longrightarrow & \mathrm{Spf}(R_{\mathrm{cris}, \lambda, \square}^+) \end{array}$$

Pour tout n , l'idéal associé au morphisme $R_{\Sigma, \Lambda, n}^{\mathrm{PD}} \rightarrow R/p$ est localement nilpotent. Comme $R_{\mathrm{cris}, \lambda, \square}^+ \rightarrow R_{\mathrm{cris}, \lambda}^+$ est étale, on peut relever la flèche $R_{\mathrm{cris}, \lambda, \square}^+ \rightarrow R_{\Sigma, \Lambda, n}^{\mathrm{PD}}$ en une unique application $R_{\mathrm{cris}, \lambda}^+ \rightarrow R_{\Sigma, \Lambda, n}^{\mathrm{PD}}$ qui fait commuter le diagramme

$$\begin{array}{ccc} R/p & \longleftarrow & R_{\mathrm{cris}, \lambda}^+ \\ \uparrow & \swarrow & \uparrow \\ R_{\Sigma, \Lambda, n}^{\mathrm{PD}} & \longleftarrow & R_{\mathrm{cris}, \lambda, \square}^+ \end{array}$$

Comme ces applications sont compatibles avec les projections $R_{\Sigma, \Lambda, n}^{\text{PD}} \rightarrow R_{\Sigma, \Lambda, n-1}^{\text{PD}}$, on obtient un morphisme $R_{\text{cris}, \lambda}^+ \rightarrow R_{\Sigma, \Lambda}^{\text{PD}}$ tel que le diagramme

$$\begin{array}{ccc} R/p & \longleftarrow & R_{\text{cris}, \lambda}^+ \\ \uparrow & \swarrow \text{---} & \uparrow \\ R_{\Sigma, \Lambda}^{\text{PD}} & \longleftarrow & R_{\text{cris}, \lambda, \square}^+ \end{array}$$

est commutatif. On a alors un diagramme commutatif

$$\begin{array}{ccccc} R_{\text{cris}, \lambda}^+ & \longrightarrow & R_{\lambda}^{[u, v]} & \longrightarrow & \mathbb{A}_{R_{\infty, \lambda}}^{[u, v]} \\ \downarrow & & \downarrow & & \downarrow \\ R_{\Sigma, \Lambda}^{\text{PD}} & \longrightarrow & R_{\Sigma, \Lambda}^{[u, v]} & \longrightarrow & \mathbb{A}_{R_{\Sigma, \Lambda, \infty}}^{[u, v]} \end{array}$$

et le résultat se déduit du diagramme commutatif suivant :

$$\begin{array}{ccccc} \tau_{\leq r} R\Gamma_{\text{syn}}(R, r) & \xleftarrow{\sim} & \tau_{\leq r} \text{Kos}(\varphi, \partial, F^r R_{\text{cris}, \lambda}^+) & \xrightarrow{\alpha_{r, \lambda}} & \tau_{\leq r} R\Gamma(G_R, \mathbb{Z}_p(r)) \\ \parallel & & \downarrow & & \parallel \\ \tau_{\leq r} R\Gamma_{\text{syn}}(R, r) & \xleftarrow{\sim} & \tau_{\leq r} \text{Kos}(\varphi, \partial, F^r R_{\Sigma, \Lambda}^{\text{PD}}) & \xrightarrow{\alpha_{r, \Sigma, \Lambda}} & \tau_{\leq r} R\Gamma(G_R, \mathbb{Z}_p(r)) \end{array} \quad \square$$

8B. Preuve du théorème 8.1. On rappelle qu'on cherche à montrer le théorème suivant :

Théorème 8.9. *Il existe un morphisme de périodes*

$$\alpha_{r, n}^0 : \tau_{\leq r} R\Gamma_{\text{syn}}(\mathfrak{X}_{\mathcal{O}_C}, r)_n \rightarrow \tau_{\leq r} R\Gamma_{\text{ét}}(\mathfrak{X}_C, \mathbb{Z}/p^n\mathbb{Z}(r)').$$

De plus, ce morphisme est un p^{Nr} -isomorphisme pour une constante N qui ne dépend que de K, p et r .

Démonstration. Soit $\mathfrak{U}^\bullet \rightarrow \mathfrak{X}$ un hyper-recouvrement affine. On note R^k l'anneau tel que $\mathfrak{U}_{\mathcal{O}_C}^k := \text{Spf}(R^k)$.

Pour chaque k , on considère (Σ_k, Λ_k) tel qu'on ait comme en (27) une immersion fermée

$$\mathfrak{U}_{\mathcal{O}_C}^k \hookrightarrow \text{Spf}(R_{\Sigma_k}^\square) \times_{\mathcal{O}_C} \prod_{\lambda_k \in \Lambda_k} \text{Spf}(R_{\lambda_k}^\square)$$

On note ensuite $\text{Spf}(R_{\Sigma_k, \Lambda_k}^{\text{PD}})$ la log-PD-enveloppe complétée de $\text{Spf}(R^k) \rightarrow \text{Spf}(\mathbb{A}_{\text{cris}}(R_{\Sigma_k, \Lambda_k}^\square))$, et

$$\text{Syn}(\mathfrak{U}_{\mathcal{O}_C}^k, \mathbb{A}_{\text{cris}}(R_{\Sigma_k, \Lambda_k}^\square), r)_n := [F^r \Omega_{R_{\Sigma_k, \Lambda_k}^{\text{PD}}}^\bullet \xrightarrow{p^r - \varphi} \Omega_{R_{\Sigma_k, \Lambda_k}^{\text{PD}}}^\bullet]_n.$$

L'application canonique $\text{Syn}(\mathfrak{U}_{\mathcal{O}_C}^k, \mathbb{A}_{\text{cris}}(R_{\Sigma_k, \Lambda_k}^\square), r)_n \rightarrow R\Gamma_{\text{syn}}(\mathfrak{U}_{\mathcal{O}_C}^k, r)_n$ est alors un quasi-isomorphisme.

De plus, on a vu que l'ensemble des $R_{\Sigma_k, \Lambda_k}^\square$ pour (Σ_k, Λ_k) comme en (27) forme un système inductif filtrant.

Le système des $\text{Syn}(\mathfrak{U}_{\mathcal{O}_C}^k, \mathbb{A}_{\text{cris}}(R_{\Sigma_k, \Lambda_k}^\square), r)_n$ est donc lui-même inductif filtrant. On en déduit un quasi-isomorphisme

$$\varinjlim_{(\Sigma_k, \Lambda_k)} \text{Syn}(\mathfrak{U}_{\mathcal{O}_C}^k, \mathbb{A}_{\text{cris}}(R_{\Sigma_k, \Lambda_k}^\square), r)_n \xrightarrow{\sim} R\Gamma_{\text{syn}}(\mathfrak{U}_{\mathcal{O}_C}^k, r)_n. \tag{33}$$

Mais on a un quasi-isomorphisme $\text{Syn}(\mathfrak{U}_{\mathcal{O}_C}^k, \mathbb{A}_{\text{cris}}(R_{\Sigma_k, \Lambda_k}^\square), r)_n \cong \text{Kos}(\varphi, \partial, R_{\Sigma_k, \Lambda_k}^{PD})_n$ pour chaque (Σ_k, Λ_k) . On vérifie que ce morphisme est fonctoriel. En effet, pour $R \rightarrow R'$ une application étale, soit (Σ, Λ) associé à R et (Σ', Λ') associé à R' . Alors si on note $\tilde{\Sigma} = \Sigma \cup \Sigma'$ et $\tilde{\Lambda} = \Lambda \cup \Lambda'$, le morphisme $R_{\Sigma, \Lambda}^\square \rightarrow R_{\tilde{\Sigma}, \tilde{\Lambda}}^\square$ décrit plus haut induit un diagramme commutatif

$$\begin{array}{ccc} \Omega_{R_{\Sigma, \Lambda}^{PD}}^\bullet & \xrightarrow{\sim} & \text{Kos}(\partial, R_{\Sigma, \Lambda}^{PD}) \\ \downarrow & & \downarrow \\ \Omega_{R_{\tilde{\Sigma}, \tilde{\Lambda}}^{PD}}^\bullet & \xrightarrow{\sim} & \text{Kos}(\partial, R_{\tilde{\Sigma}, \tilde{\Lambda}}^{PD}) \end{array}$$

Comme les systèmes sont filtrants, on a, pour tout i ,

$$H^i(\varinjlim_{(\Sigma_k, \Lambda_k)} \text{Kos}(\varphi, \partial, R_{\Sigma_k, \Lambda_k}^{PD})_n) \xrightarrow{\sim} \varinjlim_{(\Sigma_k, \Lambda_k)} H^i(\text{Kos}(\varphi, \partial, R_{\Sigma_k, \Lambda_k}^{PD})_n),$$

et de même pour les complexes $\text{Syn}(\mathfrak{U}_{\mathcal{O}_C}^k, \mathbb{A}_{\text{cris}}(R_{\Sigma_k, \Lambda_k}^\square), r)_n$. On en déduit un quasi-isomorphisme fonctoriel

$$\varinjlim_{(\Sigma_k, \Lambda_k)} \text{Syn}(\mathfrak{U}^k, \mathbb{A}_{\text{cris}}(R_{\Sigma_k, \Lambda_k}^\square), r)_n \xrightarrow{\sim} \varinjlim_{(\Sigma_k, \Lambda_k)} \text{Kos}(\varphi, \partial, R_{\Sigma_k, \Lambda_k}^{PD})_n.$$

Par ailleurs, on a construit un p^{Nr} -quasi-isomorphisme $\alpha_{r, \Sigma, \Lambda}^k$ fonctoriel de $\tau_{\leq r} \text{Kos}(\varphi, \partial, R_{\Sigma_k, \Lambda_k}^{PD})_n$ dans $\tau_{\leq r} R\Gamma(G_{R^k}, \mathbb{Z}/p^n\mathbb{Z}(r)')$, qui donne

$$\varinjlim_{(\Sigma_k, \Lambda_k)} \tau_{\leq r} \text{Kos}(\varphi, \partial, R_{\Sigma_k, \Lambda_k}^{PD})_n \xrightarrow{\sim} \tau_{\leq r} R\Gamma(G_{R^k}, \mathbb{Z}/p^n\mathbb{Z}(r)').$$

On obtient un quasi-isomorphisme fonctoriel

$$\varinjlim_{(\Sigma_k, \Lambda_k)} \tau_{\leq r} \text{Syn}(\mathfrak{U}_{\mathcal{O}_C}^k, \mathbb{A}_{\text{cris}}(R_{\Sigma_k, \Lambda_k}^\square), r)_n \xrightarrow{\sim} \tau_{\leq r} R\Gamma(G_{R^k}, \mathbb{Z}/p^n\mathbb{Z}(r)'). \tag{34}$$

En combinant les deux quasi-isomorphismes précédents, on a

$$\tau_{\leq r} R\Gamma_{\text{syn}}(\mathfrak{U}_{\mathcal{O}_C}^k, r)_n \xleftarrow[\text{(33)}]{\sim} \varinjlim_{(\Sigma_k, \Lambda_k)} \tau_{\leq r} \text{Syn}(\mathfrak{U}_{\mathcal{O}_C}^k, \mathbb{A}_{\text{cris}}(R_{\Sigma_k, \Lambda_k}^\square), r)_n \xrightarrow[\text{(34)}]{\sim} \tau_{\leq r} R\Gamma(G_{R^k}, \mathbb{Z}/p^n\mathbb{Z}(r)')$$

et ce quasi-isomorphisme est fonctoriel. On en déduit un quasi-isomorphisme

$$\tau_{\leq r} R\Gamma_{\text{syn}}(\mathfrak{U}_{\mathcal{O}_C}^\bullet, r)_n \xrightarrow{\sim} \tau_{\leq r} R\Gamma(G_{R^\bullet}, \mathbb{Z}/p^n\mathbb{Z}(r)').$$

On définit $\alpha_{r, n}^0 : \tau_{\leq r} R\Gamma_{\text{syn}}(\mathfrak{X}_{\mathcal{O}_C}, r)_n \rightarrow \tau_{\leq r} R\Gamma_{\text{ét}}(\mathfrak{X}_C, \mathbb{Z}/p^n\mathbb{Z}(r)')$ comme la composée

$$\begin{aligned} \tau_{\leq r} R\Gamma_{\text{syn}}(\mathfrak{X}_{\mathcal{O}_C}, r)_n &\rightarrow \text{hocolim}_{\text{HRF}} \tau_{\leq r} R\Gamma_{\text{syn}}(\mathfrak{U}_{\mathcal{O}_C}^\bullet, r)_n \rightarrow \text{hocolim}_{\text{HRF}} \tau_{\leq r} R\Gamma(G_{R^\bullet}, \mathbb{Z}/p^n\mathbb{Z}(r)') \\ &\rightarrow \tau_{\leq r} \text{hocolim}_{\text{HRF}} R\Gamma_{\text{ét}}(\mathfrak{U}_C^\bullet, \mathbb{Z}/p^n\mathbb{Z}(r)') \leftarrow \tau_{\leq r} R\Gamma_{\text{ét}}(\mathfrak{X}_C, \mathbb{Z}/p^n\mathbb{Z}(r)'). \end{aligned} \tag{35}$$

On va montrer qu’il s’agit d’un p^{Nr} -quasi-isomorphisme. La première et dernière flèches sont des quasi-isomorphismes par descente cohomologique (voir (11) pour la cohomologie syntomique ; le même argument donne le résultat pour la cohomologie étale). La deuxième flèche est un p^{Nr} -quasi-isomorphisme par ce qu’on vient de faire. Il reste à voir que, pour tout k , on a un quasi-isomorphisme $R\Gamma(G_{R^k}, \mathbb{Z}/p^n\mathbb{Z}(r)') \xrightarrow{\sim} R\Gamma_{\text{ét}}(\text{Sp}(R^k[1/p]), \mathbb{Z}/p^n\mathbb{Z}(r)')$. Mais cela découle du fait que $\text{Sp}(R^k[1/p])$ est $K(\pi, 1)$ pour $\mathbb{Z}/p^n\mathbb{Z}$ (voir [remarque 2.5](#)). \square

On peut maintenant considérer les faisceaux $\mathcal{H}^k(\mathcal{S}_n(r)_{\bar{\mathfrak{X}}})$ et $\bar{\iota}^* R^k \bar{j}_* \mathbb{Z}/p^n(r)'_{\mathfrak{X}_{C, \text{tr}}}$ associés aux préfaisceaux $U \mapsto H^k(U, \mathcal{S}_n(r)_{\bar{\mathfrak{X}}})$ et $U \mapsto H^k(U, \bar{\iota}^* R^k \bar{j}_* \mathbb{Z}/p^n(r)'_{\mathfrak{X}_{C, \text{tr}}})$. En utilisant l’équivalence de catégorie entre $\mathbf{Fsc}((\bar{Y})_{\text{ét}}, \mathcal{D}(\mathbb{Z}/p^n))$ et $\mathcal{D}^+((\bar{Y})_{\text{ét}}, \mathbb{Z}/p^n)$, le morphisme ci-dessus peut être vu comme un morphisme dans $\mathcal{D}^+((\bar{Y})_{\text{ét}}, \mathbb{Z}/p^n)$ et on en déduit le théorème suivant :

Théorème 8.10. *Pour tout $0 \leq k \leq r$, il existe un p^N -isomorphisme*

$$\alpha_{r,n}^0 : \mathcal{H}^k(\mathcal{S}_n(r)_{\bar{\mathfrak{X}}}) \rightarrow \bar{\iota}^* R^k \bar{j}_* \mathbb{Z}/p^n(r)'_{\mathfrak{X}_{C, \text{tr}}}$$

où N est un entier qui dépend de p et de r , mais pas de \mathfrak{X} ni de n .

8C. Conjecture semi-stable. On suppose toujours que \mathfrak{X} est propre à réduction semi-stable sur \mathcal{O}_K , sans diviseur à l’infini. On rappelle qu’on a la cohomologie de Hyodo–Kato $R\Gamma_{\text{HK}}(\mathfrak{X}) := R\Gamma_{\text{cris}}(\mathfrak{X}_k/W(k)^0)_{\mathbb{Q}}$ et si D est un (φ, N) -module filtré, $D\{r\}$ désigne le module D muni du Frobenius $p^r\varphi$ et D_K est muni de la filtration $(F^{\bullet+r} D_K)$. Le but de cette partie est de prouver la conjecture semi-stable de Fontaine–Jannsen.

Théorème 8.11. *Soit \mathfrak{X} un schéma formel propre semi-stable sur \mathcal{O}_K . On a un isomorphisme \mathbb{B}_{st} -linéaire, Galois équivariant*

$$\tilde{\alpha}^0 : H_{\text{ét}}^i(\mathfrak{X}_C, \mathbb{Q}_p) \otimes_{\mathbb{Q}_p} \mathbb{B}_{\text{st}} \xrightarrow{\sim} H_{\text{HK}}^i(\mathfrak{X}) \otimes_F \mathbb{B}_{\text{st}}. \tag{36}$$

De plus, cet isomorphisme préserve l’action du Frobenius et celle de l’opérateur de monodromie et après tensorisation par \mathbb{B}_{dR} , il induit un isomorphisme filtré

$$H_{\text{ét}}^i(\mathfrak{X}_C, \mathbb{Q}_p) \otimes_{\mathbb{Q}_p} \mathbb{B}_{\text{dR}} \xrightarrow{\sim} H_{\text{dR}}^i(\mathfrak{X}_K) \otimes_K \mathbb{B}_{\text{dR}}. \tag{37}$$

Pour cela, commençons par rappeler les lemmes suivants [[Colmez et Nizioł 2017](#), Propositions 5.20 et 5.22] :

Lemme 8.12. *Il existe un quasi-isomorphisme naturel*

$$R\Gamma_{\text{syn}}(\mathfrak{X}_{\mathcal{O}_C}, r)_{\mathbb{Q}} \xrightarrow{\sim} [[R\Gamma_{\text{HK}}(\mathfrak{X}) \otimes_F \mathbb{B}_{\text{st}}^+]^{\varphi=p^r, N=0} \xrightarrow{\iota_{\text{HK}}} (R\Gamma_{\text{dR}}(\mathfrak{X}_K) \otimes_K \mathbb{B}_{\text{dR}}^+)/F^r]$$

où ι_{HK} est induit par le quasi-isomorphisme de Hyodo–Kato $\iota_{\text{HK}} : R\Gamma_{\text{HK}}(\mathfrak{X}) \otimes_F K \xrightarrow{\sim} R\Gamma_{\text{dR}}(\mathfrak{X}_K)$. De plus, pour tout i , $H^i[R\Gamma_{\text{HK}}(\mathfrak{X}) \otimes_F \mathbb{B}_{\text{st}}^+]^{\varphi=p^r, N=0} \cong (H_{\text{HK}}^i(\mathfrak{X}) \otimes_F \mathbb{B}_{\text{st}}^+)^{\varphi=p^r, N=0}$ et si $i < r$, la suite exacte longue associée induit une suite exacte courte

$$0 \rightarrow H_{\text{syn}}^i(\mathfrak{X}_{\mathcal{O}_C}, r)_{\mathbb{Q}} \rightarrow (H_{\text{HK}}^i(\mathfrak{X}) \otimes_F \mathbb{B}_{\text{st}}^+)^{\varphi=p^r, N=0} \rightarrow (H_{\text{dR}}^i(\mathfrak{X}_K) \otimes_K \mathbb{B}_{\text{dR}}^+)/F^r \rightarrow 0.$$

Lemme 8.13. *Le (φ, N) -module filtré $(H_{\text{HK}}^i(\mathfrak{X}), H_{\text{dR}}^i(\mathfrak{X}_K), \iota_{\text{HK}})$ est faiblement admissible, et pour $i \leq r$ on a un isomorphisme (Frobenius-équivariant)*

$$H_{\text{syn}}^i(\mathfrak{X}_{\mathcal{O}_C}, r)_{\mathbb{Q}} \otimes_{\mathbb{Q}_p} \mathbb{B}_{\text{st}} \xrightarrow{\sim} H_{\text{HK}}^i(\mathfrak{X}) \otimes_F \mathbb{B}_{\text{st}}\{-r\}.$$

Remarque 8.14. Le résultat de ce lemme reste vrai pour tout ensemble de triplets $D^i = (D_{\text{st}}^i, D_{\text{dR}}^i, \iota^i)$ où, pour tout i , les conditions suivantes sont vérifiées :

- (1) D_{st}^i est un F -espace vectoriel de dimension finie muni d'un endomorphisme de Frobenius φ bijectif semi-linéaire et d'un opérateur de monodromie N tels que $N\varphi = p\varphi N$.
- (2) D_{dR}^i est un K -espace vectoriel de dimension finie muni d'une filtration décroissante, séparée et exhaustive.
- (3) $\iota^i : D_{\text{st}}^i \rightarrow D_{\text{dR}}^i$ est F -linéaire.

Il faut de plus que $F^{i+1}D_{\text{dR}}^i = 0$ et qu'on ait une suite exacte longue

$$\cdots \rightarrow H^i(r) \rightarrow X_{\text{st}}^r(D^i) \rightarrow X_{\text{dR}}^r(D^i) \rightarrow H^{i+1}(r) \rightarrow \cdots$$

avec $X_{\text{st}}^r(D^i) = (t^{-r}\mathbb{B}_{\text{st}}^+ \otimes_F D_{\text{st}})^{\varphi=1, N=0}$, $X_{\text{dR}}^r(D^i) = (t^{-r}\mathbb{B}_{\text{dR}}^+ \otimes_K D_{\text{dR}})/F^0$ et où $\dim_{\mathbb{Q}_p} H^i(r)$ est finie pour $i \leq r$. La preuve utilise la théorie des espaces de Banach–Colmez ; voir [Colmez 2002; Colmez et Nizioł 2017, §5.2.2].

Démonstration du théorème 8.11. En vertu du corollaire 8.2, pour tout $i \leq r$, on a un isomorphisme $\alpha_r^0 : H_{\text{syn}}^i(\mathfrak{X}_{\mathcal{O}_C}, r)_{\mathbb{Q}} \xrightarrow{\sim} H_{\text{ét}}^i(\mathfrak{X}_C, \mathbb{Q}_p(r))$, et en utilisant le lemme 8.12, on obtient un morphisme

$$H_{\text{ét}}^i(\mathfrak{X}_C, \mathbb{Q}_p(r)) \xleftarrow{\sim} H_{\text{syn}}^i(\mathfrak{X}_{\mathcal{O}_C}, r)_{\mathbb{Q}} \rightarrow (H_{\text{HK}}^i(\mathfrak{X}) \otimes_F \mathbb{B}_{\text{st}})^{\varphi=p^r, N=0}.$$

Le morphisme de périodes $\tilde{\alpha}^0$ est alors donné par

$$\begin{aligned} H_{\text{ét}}^i(\mathfrak{X}_C, \mathbb{Q}_p) \otimes_{\mathbb{Q}_p} \mathbb{B}_{\text{st}} &\xleftarrow{\sim} H_{\text{ét}}^i(\mathfrak{X}_C, \mathbb{Q}_p(r)) \otimes_{\mathbb{Q}_p} \mathbb{B}_{\text{st}}\{r\} \xleftarrow{\sim} H_{\text{syn}}^i(\mathfrak{X}_{\mathcal{O}_C}, r)_{\mathbb{Q}} \otimes_{\mathbb{Q}_p} \mathbb{B}_{\text{st}}\{r\} \\ &\rightarrow H_{\text{HK}}^i(\mathfrak{X}) \otimes_F \mathbb{B}_{\text{st}} \quad (38) \end{aligned}$$

et la flèche $H_{\text{syn}}^i(\mathfrak{X}_{\mathcal{O}_C}, r)_{\mathbb{Q}} \otimes_{\mathbb{Q}_p} \mathbb{B}_{\text{st}}\{r\} \rightarrow H_{\text{HK}}^i(\mathfrak{X}) \otimes_F \mathbb{B}_{\text{st}}$ est un isomorphisme par le lemme 8.13. On obtient l'isomorphisme (36). Enfin, par construction de α_r^0 , l'application ci-dessus est Galois-équivariante, elle est compatible avec l'action de φ et de N et avec la filtration après tensorisation par \mathbb{B}_{dR} . \square

9. Comparaison des morphismes de périodes

On suppose que \mathfrak{X} est un schéma formel propre à réduction semi-stable sur \mathcal{O}_K , sans diviseur à l'infini. On a construit, dans la section précédente, un isomorphisme

$$\begin{aligned} \tilde{\alpha}^0 &: H_{\text{ét}}^i(\mathfrak{X}_C, \mathbb{Q}_p) \otimes_{\mathbb{Q}_p} \mathbb{B}_{\text{st}} \xrightarrow{\sim} H_{\text{HK}}^i(\mathfrak{X}) \otimes_F \mathbb{B}_{\text{st}}, \\ \tilde{\alpha}_{\text{dR}}^0 &: H_{\text{ét}}^i(\mathfrak{X}_C, \mathbb{Q}_p) \otimes_{\mathbb{Q}_p} \mathbb{B}_{\text{dR}} \xrightarrow{\sim} H_{\text{dR}}^i(\mathfrak{X}_K) \otimes_K \mathbb{B}_{\text{dR}}. \end{aligned}$$

D'autres démonstrations de la conjecture de Fontaine–Jannsen ont également été données par Česnavičius et Koshikawa [2019] et par Tsuji [1999]. Le morphisme de périodes utilisé par Tsuji est l'application de Fontaine–Messing, $\tilde{\alpha}^{\text{FM}}$ définie ci-dessous. Česnavičius et Koshikawa définissent, eux, un morphisme de périodes $\tilde{\alpha}^{\text{CK}}$ en généralisant la construction de Bhatt et al. [2018] et dont on rappelle la construction plus loin. Le but de cette section est d'utiliser $\tilde{\alpha}^0$ pour montrer que ces deux morphismes de périodes $\tilde{\alpha}^{\text{CK}}$ et $\tilde{\alpha}^{\text{FM}}$ coïncident.

9A. Comparaison de $\tilde{\alpha}^{\text{FM}}$ et $\tilde{\alpha}^0$. On commence par comparer l'application de Fontaine–Messing avec le morphisme construit dans le chapitre précédent.

Théorème 9.1. *Soit \mathfrak{X} un schéma formel propre semi-stable sur \mathcal{O}_K . Les isomorphismes α_r^{FM} et α_r^0 de $H_{\text{ét}}^i(\mathfrak{X}_C, \mathbb{Q}_p(r))$ dans $H_{\text{syn}}^i(\mathfrak{X}_{\mathcal{O}_C}, r)_{\mathbb{Q}}$ sont égaux. En particulier, les morphismes de périodes*

$$\begin{aligned} \tilde{\alpha}^{\text{FM}}, \tilde{\alpha}^0 &: H_{\text{ét}}^i(\mathfrak{X}_C, \mathbb{Q}_p) \otimes_{\mathbb{Q}_p} \mathbb{B}_{\text{st}} \rightarrow H_{\text{HK}}^i(\mathfrak{X}) \otimes_F \mathbb{B}_{\text{st}}, \\ \tilde{\alpha}_{\text{dR}}^{\text{FM}}, \tilde{\alpha}_{\text{dR}}^0 &: H_{\text{ét}}^i(\mathfrak{X}_C, \mathbb{Q}_p) \otimes_{\mathbb{Q}_p} \mathbb{B}_{\text{dR}} \rightarrow H_{\text{HK}}^i(\mathfrak{X}) \otimes_F \mathbb{B}_{\text{dR}} \end{aligned}$$

sont égaux.

Il suffit de montrer que les applications entières sont p^N -égales pour une certaine constante N . Le théorème 7.5 donne l'égalité locale. Pour obtenir l'égalité entre les morphismes globaux, on va commencer par construire des applications $\alpha_{r, \Sigma, \Lambda}^{\text{FM}}$ et les comparer au $\alpha_{r, \Sigma, \Lambda}^0$ définis plus haut.

On définit les anneaux suivants :

- $\mathbb{E}_{R_{\Sigma, \Lambda}}^{\text{PD}} = SA$ (resp. $\mathbb{E}_{R_{\Sigma, \Lambda}}^{[u, v]}$) pour $S = A = R_{\Sigma, \Lambda}^{\text{PD}}$ (resp. $R_{\Sigma, \Lambda}^{[u, v]}$).
- $\mathbb{E}_{R_{\Sigma, \Lambda, \infty}}^{\text{PD}} = SA$ (resp. $\mathbb{E}_{R_{\Sigma, \infty}}^{[u, v]}$) pour $S = R_{\Sigma, \Lambda}^{\text{PD}}$ (resp. $R_{\Sigma, \Lambda}^{[u, v]}$) et $A = \mathbb{A}_{\text{cris}}(R_{\Sigma, \Lambda, \infty})$ (resp. $\mathbb{A}_{R_{\Sigma, \Lambda, \infty}}^{[u, v]}$).
- $\mathbb{E}_{\bar{R}_{\Sigma, \Lambda}}^{\text{PD}} = SA$ (resp. $\mathbb{E}_{\bar{R}_{\Sigma, \Lambda}}^{[u, v]}$) pour $S = R_{\Sigma, \Lambda}^{\text{PD}}$ (resp. $R_{\Sigma, \Lambda}^{[u, v]}$) et $A = \mathbb{A}_{\text{cris}}(\bar{R})$ (resp. $\mathbb{A}_{\bar{R}}^{[u, v]}$).

On ne dispose plus ici des lemmes de Poincaré mais on peut montrer qu'on a un quasi-isomorphisme

$$\tau_{\leq r} \text{Kos}(\varphi, \partial, F^r \mathbb{E}_{R_{\Sigma, \Lambda}}^{\text{PD}}) \xleftarrow{\sim} \tau_{\leq r} \text{Kos}(\varphi, \partial, F^r \mathbb{A}_{\text{cris}}(\bar{R}))$$

en se ramenant au cas où on ne travaille qu'avec une seule coordonnée $\lambda \in \Lambda$. En effet, si on fixe un tel λ , l'application $R_{\text{cris}, \lambda}^+ \rightarrow R_{\Sigma, \Lambda}^{\text{PD}}$ induit un diagramme commutatif

$$\begin{array}{ccc} \tau_{\leq r} \text{Kos}(\varphi, \partial, F^r \mathbb{E}_{R_{\lambda}}^{\text{PD}}) & \xleftarrow{\sim} & \tau_{\leq r} \text{Kos}(\varphi, \partial, F^r \mathbb{A}_{\text{cris}}(\bar{R})) \\ \downarrow \wr & & \parallel \\ \tau_{\leq r} \text{Kos}(\varphi, \partial, F^r \mathbb{E}_{\bar{R}_{\Sigma, \Lambda}}^{\text{PD}}) & \xleftarrow{\sim} & \tau_{\leq r} \text{Kos}(\varphi, \partial, F^r \mathbb{A}_{\text{cris}}(\bar{R})) \end{array}$$

où $\mathbb{E}_{R_{\lambda}}^{\text{PD}}$ est l'anneau SA pour $A = \mathbb{A}_{\text{cris}}(\bar{R})$ et $S = R_{\text{cris}, \lambda}^+$. La première flèche verticale est un quasi-isomorphisme car les complexes $\text{Kos}(\varphi, \partial, F^r \mathbb{E}_{R_{\lambda}}^{\text{PD}})$ et $\text{Kos}(\varphi, \partial, F^r \mathbb{E}_{\bar{R}_{\Sigma, \Lambda}}^{\text{PD}})$ calculent tous les deux la cohomologie syntomique $\text{Syn}(\bar{R}, r)$. On en déduit que la flèche horizontale de la ligne du bas est un quasi-isomorphisme.

On montre de la même façon qu'on a un quasi-isomorphisme

$$\tau_{\leq r} \text{Kos}(\varphi, \partial, F^r \mathbb{E}_{\overline{R}_{\Sigma, \Lambda}}^{[u, v]}) \xleftarrow{\sim} \tau_{\leq r} \text{Kos}(\varphi, \partial, F^r \mathbb{A}_{\overline{R}}^{[u, v]}).$$

L'application de Fontaine–Messing $\alpha_{\Sigma, \Lambda}^{\text{FM}}$ est donnée par la composée

$$\begin{aligned} \tau_{\leq r} \text{Kos}(\varphi, \partial, F^r R_{\Sigma, \Lambda}^{\text{PD}}) &\rightarrow \tau_{\leq r} C(G_R, \text{Kos}(\varphi, \partial, F^r \mathbb{E}_{\overline{R}_{\Sigma, \Lambda}}^{\text{PD}})) \xleftarrow{\sim} \tau_{\leq r} C(G_R, \text{Kos}(\varphi, F^r \mathbb{A}_{\text{cris}}(\overline{R}))) \\ &\xleftarrow{\sim} \tau_{\leq r} C(G_R, \mathbb{Z}_p(r)'). \end{aligned}$$

On a le lemme suivant :

Lemme 9.2. *Il existe N qui ne dépend ni de R , ni de Σ et Λ telle que l'application de Fontaine–Messing $\alpha_{r, \Sigma, \Lambda}^{\text{FM}}$ est p^{Nr} -égale à l'application $\alpha_{r, \Sigma, \Lambda}^0$.*

Démonstration. Le résultat se déduit d'un diagramme similaire à celui de la preuve du [théorème 7.5](#). La différence principale est que les flèches qui vont de la troisième vers la deuxième ligne sont maintenant des morphismes de bord. Il est aussi à noter que les flèches horizontales qui vont de la troisième colonne vers la deuxième ne sont (a priori) plus des quasi-isomorphismes dans ce cas, à l'exception de celles de la première, deuxième et dernière lignes. \square

Démonstration du [théorème 9.1](#). L'application globale

$$\alpha_r^{\text{FM}} : \tau_{\leq r} R\Gamma_{\text{syn}}(\mathfrak{X}_{\mathcal{O}_C}, r) \rightarrow \tau_{\leq r} R\Gamma_{\text{ét}}(\mathfrak{X}_C, \mathbb{Z}_p(r)')$$

s'obtient de la même façon que dans la preuve du [théorème 8.1](#) : elle est donnée par la composée

$$\begin{aligned} \tau_{\leq r} R\Gamma_{\text{syn}}(\mathfrak{X}_{\mathcal{O}_C}, r)_n &\rightarrow \text{hocolim}_{\text{HRF}} \tau_{\leq r} R\Gamma_{\text{syn}}(\mathfrak{U}_{\mathcal{O}_C}^\bullet, r) \rightarrow \text{hocolim}_{\text{HRF}} \tau_{\leq r} R\Gamma(G_{R^\bullet}, \mathbb{Z}_p(r)') \\ &\rightarrow \tau_{\leq r} \text{hocolim}_{\text{HRF}} R\Gamma_{\text{ét}}(\mathfrak{U}_C^\bullet, \mathbb{Z}_p(r)') \leftarrow \tau_{\leq r} R\Gamma_{\text{ét}}(\mathfrak{X}_C, \mathbb{Z}_p(r)'). \end{aligned} \quad (39)$$

où le quasi-isomorphisme (fonctoriel) $\tau_{\leq r} R\Gamma_{\text{syn}}(\mathfrak{U}_{\mathcal{O}_C}^\bullet, r) \rightarrow \tau_{\leq r} R\Gamma(G_{R^\bullet}, \mathbb{Z}_p(r)')$ pour un hyper-recouvrement affine $\mathfrak{U}^\bullet = \text{Spf}(R^\bullet) \rightarrow \mathfrak{X}$ est induit par

$$\tau_{\leq r} R\Gamma_{\text{syn}}(\mathfrak{U}_{\mathcal{O}_C}^k, r) \xleftarrow{(33)} \varinjlim_{(\Sigma_k, \Lambda_k)} \tau_{\leq r} \text{Syn}(\mathfrak{U}_{\mathcal{O}_C}^k, \mathbb{A}_{\text{cris}}(R_{\Sigma_k, \Lambda_k}^\square), r) \xrightarrow{\varinjlim \alpha_{r, \Sigma_k, \Lambda_k}^{\text{FM}}} \tau_{\leq r} R\Gamma(G_{R^k}, \mathbb{Z}_p(r)'). \quad (40)$$

Le [lemme 9.2](#) donne la p^{Nr} -égalité entre les morphismes $\varinjlim \alpha_{r, \Sigma_k, \Lambda_k}^{\text{FM}}$ et $\varinjlim \alpha_{r, \Sigma_k, \Lambda_k}^0$ et donc entre les morphismes induits (40). On en déduit que $\alpha_r^{\text{FM}} : \tau_{\leq r} R\Gamma_{\text{syn}}(\mathfrak{X}_{\mathcal{O}_C}, r) \rightarrow \tau_{\leq r} R\Gamma_{\text{ét}}(\mathfrak{X}_C, \mathbb{Z}_p(r)')$ et $\alpha_r^0 : \tau_{\leq r} R\Gamma_{\text{syn}}(\mathfrak{X}_{\mathcal{O}_C}, r) \rightarrow \tau_{\leq r} R\Gamma_{\text{ét}}(\mathfrak{X}_C, \mathbb{Z}_p(r)')$ sont p^{Nr} -égales. En inversant p , on obtient l'égalité entre les morphismes rationnels et on en déduit finalement $\tilde{\alpha}^{\text{FM}} = \tilde{\alpha}^0$. \square

9B. Comparaison de $\tilde{\alpha}^{\text{CK}}$ et $\tilde{\alpha}^0$. On considère maintenant le morphisme de périodes

$$\tilde{\alpha}^{\text{CK}} : H_{\text{ét}}^i(\mathfrak{X}_C, \mathbb{Q}_p) \otimes_{\mathbb{Q}_p} \mathbb{B}_{\text{st}} \xrightarrow{\sim} H_{\text{HK}}^i(\mathfrak{X}) \otimes_F \mathbb{B}_{\text{st}}$$

défini par Bhatt et al. [2018] dans le cas où \mathfrak{X} est à bonne réduction et par Česnavičius et Koshikawa [2019] pour \mathfrak{X} à réduction semi-stable. On rappelle rapidement sa définition locale dans la section qui suit. On montre ensuite qu'il est égal à $\tilde{\alpha}^0$.

9B1. *Définition de l'application locale γ^{CK} .*

Définition 9.3. [Bhatt et al. 2018, §6] Soit A un anneau et K un complexe de A -modules, sans f -torsion. On note $\eta_f(K)$ le sous-complexe de $K[1/f]$ dont le i -ième terme est donné par

$$(\eta_f K)^i := \{x \in f^i K^i : dx \in f^{i+1} K^{i+1}\}.$$

L'application $K^i \rightarrow (\eta_f K)^i, x \mapsto f^i x$ induit un isomorphisme $H^i(K)/H^i(K)[f] \cong H^i(\eta_f K)$ (où $H^i(K)[f]$ désigne la f -torsion de $H^i(K)$) et on en déduit que si $K \rightarrow K'$ est un quasi-isomorphisme alors $\eta_f K \rightarrow \eta_f K'$ l'est aussi. On définit le foncteur $L\eta_f$ de $D(A)$ dans $D(A)$ de la façon suivante : pour K dans $D(A)$ on choisit un complexe C quasi-isomorphe à K et dont les termes sont sans f -torsion et on pose $L\eta_f K := \eta_f C$.

Soit \mathfrak{X} un schéma formel sur \mathcal{O}_K , à réduction semi-stable et soit $X := \mathfrak{X}_C$ la fibre générique de $\mathfrak{X}_{\mathcal{O}_C}$, vue comme une variété analytique rigide. On note \mathcal{O}_X le faisceau structural du site pro-étale $X_{\text{proét}}$, \mathcal{O}_X^+ le faisceau intégral associé et $\widehat{\mathcal{O}}_X^+$ sa complétion. On définit le complexe de faisceaux $\mathbb{A}_{\text{inf}, X}$ comme la complétion p -adique dérivée¹¹ de $W(\widehat{\mathcal{O}}_X^{+,b})$. On considère alors le complexe de faisceaux

$$A\Omega_{\mathfrak{X}_{\mathcal{O}_C}} := L\eta_\mu(Rv_*(\mathbb{A}_{\text{inf}, X})) \in \mathcal{D}(\mathfrak{X}_{\mathcal{O}_C, \text{ét}}, \mathbb{A}_{\text{inf}}),$$

où $v : X_{\text{proét}} \rightarrow \mathfrak{X}_{\mathcal{O}_C, \text{ét}}$ est la projection. Dans [Bhatt et al. 2018, Lemma 5.6], il est montré que l'application naturelle $\mathbb{A}_{\text{inf}} \rightarrow \mathbb{A}_{\text{inf}, X}$ induit un morphisme

$$R\Gamma(X_{\text{ét}}, \mathbb{Z}_p) \otimes_{\mathbb{Z}_p}^L \mathbb{A}_{\text{inf}} \cong R\Gamma(X_{\text{proét}}, \mathbb{Z}_p) \otimes_{\mathbb{Z}_p}^L \mathbb{A}_{\text{inf}} \rightarrow R\Gamma_{\text{proét}}(X, \mathbb{A}_{\text{inf}, X})$$

tel que la cohomologie de son cône est tuée par $W(\mathfrak{m}_C^b)$ (où \mathfrak{m}_C est l'idéal maximal de \mathcal{O}_C). Comme $\mu = [\varepsilon] - 1$ est dans $W(\mathfrak{m}_C^b)$, on en déduit le résultat suivant :

Théorème 9.4 [Česnavičius et Koshikawa 2019, Theorem 2.3]. *Si \mathfrak{X} est propre sur \mathcal{O}_K , il existe un quasi-isomorphisme*

$$R\Gamma(X_{\text{ét}}, \mathbb{Z}_p) \otimes_{\mathbb{Z}_p}^L \mathbb{A}_{\text{inf}} \left[\frac{1}{\mu} \right] \xrightarrow{\sim} R\Gamma_{\text{ét}}(\mathfrak{X}_{\mathcal{O}_C}, A\Omega_{\mathfrak{X}_{\mathcal{O}_C}}) \otimes_{\mathbb{A}_{\text{inf}}}^L \mathbb{A}_{\text{inf}} \left[\frac{1}{\mu} \right]. \tag{41}$$

On suppose maintenant que $\mathfrak{X}_{\mathcal{O}_C} = \text{Spf}(R)$ avec R étale sur R_\square . On reprend les notations $R_{\text{inf}}^+, R_{\text{cris}}^+$ de la section 2B2 et $\mathbb{A}_R^+, \mathbb{A}_{\text{cris}}(R)$ de la section 5A (on rappelle que $R_{\text{inf}}^+ \cong \mathbb{A}_R^+$ et $R_{\text{cris}}^+ \cong \mathbb{A}_{\text{cris}}(R)$). On définit R_∞ comme avant. On a alors que R_∞ est perfectoïde et muni d'une action de Γ_R . Ainsi, la tour notée par abus de notation $X_\infty := \varprojlim \text{Spa}(R_m[1/p], R_m)$ est un recouvrement affinoïde perfectoïde de $\mathfrak{X}_{\mathcal{O}_C}$.

Théorème 9.5 [Česnavičius et Koshikawa 2019, §3.3]. (1) *On a des quasi-isomorphismes*

$$\begin{aligned} L\eta_{(\zeta_p-1)}(R\Gamma(\Gamma_R, R_\infty)) &\xrightarrow{\sim} L\eta_{(\zeta_p-1)}(R\Gamma_{\text{proét}}(X, \widehat{\mathcal{O}}_X^+)), \\ L\eta_\mu(R\Gamma(\Gamma_R, \mathbb{A}_{\text{inf}}(R_\infty))) &\xrightarrow{\sim} L\eta_\mu(R\Gamma_{\text{proét}}(X, \mathbb{A}_{\text{inf}, X})). \end{aligned} \tag{42}$$

11. La complétion p -adique dérivée \widehat{K} d'un complexe $K \in D(X_{\text{proét}}, \mathbb{Z}_p)$ est définie localement par $\widehat{K}|_U = \text{holim}_n(K|_U \otimes_{\mathbb{Z}}^L \mathbb{Z}/p^n)$.

(2) Plus généralement, si R'_∞ définit un recouvrement affinoïde perfectoïde de R muni d'une action d'un groupe Γ' et tel que R'_∞ est un raffinement de R_∞ , alors on a des quasi-isomorphismes

$$\begin{aligned} L\eta_{(\xi_p-1)}(R\Gamma(\Gamma', R'_\infty)) &\xrightarrow{\sim} L\eta_{(\xi_p-1)}(R\Gamma_{\text{proét}}(X, \widehat{O}_X^+)), \\ L\eta_\mu(R\Gamma(\Gamma', \mathbb{A}_{\text{inf}}(R'_\infty))) &\xrightarrow{\sim} L\eta_\mu(R\Gamma_{\text{proét}}(X, \mathbb{A}_{\text{inf}, X})). \end{aligned} \tag{43}$$

Le but est de construire un quasi-isomorphisme entre $R\Gamma_{\text{cris}}((R/p)/\mathbb{A}_{\text{cris}})$ et $R\Gamma(X_{\text{ét}}, \mathbb{Z}_p) \otimes_{\mathbb{Z}_p}^L \mathbb{A}_{\text{cris}}$. L'application va être induite par la composée

$$\text{Kos}(\partial, \mathbb{A}_{\text{cris}}(R)) \xrightarrow{\tilde{\beta}} \eta_\mu \text{Kos}(\Gamma_R, \mathbb{A}_{\text{cris}}(R)) \rightarrow \eta_\mu \text{Kos}(\Gamma_R, \mathbb{A}_{\text{cris}}(R_\infty))$$

où $\tilde{\beta}$ est construit ci-dessous. Le problème est que l'anneau \mathbb{A}_{cris} vient de la complétion d'un anneau qui n'est pas de type fini sur \mathbb{A}_{inf} et en particulier, $\mathbb{A}_{\text{cris}}/\mu$ n'est pas p -adiquement séparé. Notamment, $\eta_\mu \text{Kos}(\Gamma_R, \mathbb{A}_{\text{cris}}(R_\infty))$ ne calcule pas nécessairement $R\Gamma(X_{\text{ét}}, \mathbb{Z}_p) \otimes_{\mathbb{Z}_p}^L \mathbb{A}_{\text{cris}}$. Pour contourner cette difficulté, Bhatt et al. passent par l'anneau $\mathbb{A}_{\text{cris}}^{(m)}$, construit à partir du même anneau que \mathbb{A}_{cris} mais tronqué en degré m .

Plus précisément, pour m dans \mathbb{N} , on note $\mathbb{A}_{\text{cris}}^{(m)}$ la complétion p -adique de $\mathbb{A}_{\text{inf}}[\xi^k/k!, k \leq m]$. On a toujours une surjection $\theta : \mathbb{A}_{\text{cris}}^{(m)} \rightarrow \mathcal{O}_C$ et on étend le Frobenius de \mathbb{A}_{inf} en $\varphi : \mathbb{A}_{\text{cris}}^{(m)} \rightarrow \mathbb{A}_{\text{cris}}^{(m)}$. Remarquons que pour $m < p$, on a $\mathbb{A}_{\text{cris}}^{(m)} = \mathbb{A}_{\text{inf}}$ et pour $m \geq p$, les topologies p -adique et (p, μ) -adique sur $\mathbb{A}_{\text{cris}}^{(m)}$ coïncident. On peut de plus identifier \mathbb{A}_{cris} à la complétion p -adique de $\varinjlim \mathbb{A}_{\text{cris}}^{(m)}$. On définit de la même façon $\mathbb{A}_{\text{cris}}^{(m)}(\bar{R})$ et $\mathbb{A}_{\text{cris}}^{(m)}(R_\infty)$. Enfin, soit $\mathbb{A}_{\text{cris}}^{(m)}(R) := \mathbb{A}_R^+ \widehat{\otimes}_{\mathbb{A}_{\text{inf}}} \mathbb{A}_{\text{cris}}^{(m)}$.

On a (voir [Bhatt et al. 2018, Corollary 12.7]) des isomorphismes

$$\begin{aligned} R\Gamma(\Gamma_R, \mathbb{A}_{\text{inf}}(R_\infty)) \widehat{\otimes}_{\mathbb{A}_{\text{inf}}}^L \mathbb{A}_{\text{cris}}^{(m)} &\xrightarrow{\sim} R\Gamma(\Gamma_R, \mathbb{A}_{\text{cris}}^{(m)}(R_\infty)), \\ L\eta_\mu(R\Gamma(\Gamma_R, \mathbb{A}_{\text{inf}}(R_\infty))) \widehat{\otimes}_{\mathbb{A}_{\text{inf}}}^L \mathbb{A}_{\text{cris}}^{(m)} &\xrightarrow{\sim} L\eta_\mu(R\Gamma(\Gamma_R, \mathbb{A}_{\text{cris}}^{(m)}(R_\infty))). \end{aligned} \tag{44}$$

En combinant les résultats (42) et (44), on obtient :

Corollaire 9.6. *Il existe un quasi-isomorphisme naturel*

$$R\Gamma_{\text{ét}}(\mathfrak{X}_{\mathcal{O}_C}, A\Omega_{\mathfrak{X}_{\mathcal{O}_C}}) \widehat{\otimes}_{\mathbb{A}_{\text{inf}}}^L \mathbb{A}_{\text{cris}} \xrightarrow{\sim} \widehat{\left(\varinjlim_m (\eta_\mu(\text{Kos}(\Gamma_R, \mathbb{A}_{\text{cris}}^{(m)}(R_\infty)))) \right)}.$$

On a alors le théorème suivant (voir [Bhatt et al. 2018, Theorem 12.1; Česnavičius et Koshikawa 2019, Theorem 5.4]) :

Théorème 9.7. *Il existe un quasi-isomorphisme Frobenius-équivariant*

$$\gamma^{\text{CK}} : R\Gamma_{\text{cris}}((\mathfrak{X}_{\mathcal{O}_C}/p)/\mathbb{A}_{\text{cris}}) \xrightarrow{\sim} R\Gamma_{\text{ét}}(\mathfrak{X}_{\mathcal{O}_C}, A\Omega_{\mathfrak{X}_{\mathcal{O}_C}}) \widehat{\otimes}_{\mathbb{A}_{\text{inf}}}^L \mathbb{A}_{\text{cris}}. \tag{45}$$

Démonstration. Les détails de la preuve sont donnés dans [Česnavičius et Koshikawa 2019, § 5.5–5.16]. On rappelle ici rapidement la construction de γ^{CK} . Pour $m \geq p^2$, on définit $\tilde{\beta}^{(m)} : \text{Kos}(\partial, \mathbb{A}_{\text{cris}}^{(m)}(R)) \rightarrow$

$\eta_\mu \text{Kos}(\Gamma_R, \mathbb{A}_{\text{cris}}^{(m)}(R))$ par

$$\begin{array}{ccccccc} \mathbb{A}_{\text{cris}}^{(m)}(R) & \xrightarrow{(\partial_j)} & (\mathbb{A}_{\text{cris}}^{(m)}(R))^{J_1} & \longrightarrow & \dots & \longrightarrow & (\mathbb{A}_{\text{cris}}^{(m)}(R))^{J_n} \longrightarrow \dots \\ \downarrow \text{Id} & & \downarrow (\tilde{\beta}_j) & & & & \downarrow (\tilde{\beta}_{j_1} \cdots \tilde{\beta}_{j_n}) \\ \mathbb{A}_{\text{cris}}^{(m)}(R) & \xrightarrow{(\gamma_j-1)} & (\mu \mathbb{A}_{\text{cris}}^{(m)}(R))^{J_1} & \longrightarrow & \dots & \longrightarrow & (\mu^n \mathbb{A}_{\text{cris}}^{(m)}(R))^{J_n} \longrightarrow \dots \end{array}$$

avec $\tilde{\beta}_j := \sum_{n \geq 1} (t^n/n!) \partial_j^{n-1}$. L'application $\tilde{\beta}^{(m)}$ est bien définie puisqu'elle est induite par le morphisme de complexes

$$\begin{array}{ccc} \mathbb{A}_{\text{cris}}^{(m)}(R) & \xrightarrow{\partial_j} & \mathbb{A}_{\text{cris}}^{(m)}(R) \\ \downarrow \text{Id} & & \downarrow \tilde{\beta}_j \\ \mathbb{A}_{\text{cris}}^{(m)}(R) & \xrightarrow{\gamma_j-1} & \mathbb{A}_{\text{cris}}^{(m)}(R) \end{array}$$

et $\tilde{\beta}_j \partial_j = \gamma_j - 1$ (en utilisant $\text{Kos}(\partial, \mathbb{A}_{\text{cris}}^{(m)}(R)) = \bigotimes_{j=1}^d (\mathbb{A}_{\text{cris}}^{(m)}(R) \xrightarrow{\partial_j} \mathbb{A}_{\text{cris}}^{(m)}(R))$). Ce sont des isomorphismes par le lemme 5.15 de [Česnavičius et Koshikawa 2019]. Pour obtenir le résultat, il suffit ensuite de montrer que l'inclusion $\mathbb{A}_{\text{cris}}^{(m)}(R) \hookrightarrow \mathbb{A}_{\text{cris}}^{(m)}(R_\infty)$ induit un isomorphisme

$$\eta_\mu \text{Kos}(\Gamma_R, \mathbb{A}_{\text{cris}}^{(m)}(R)) \xrightarrow{\sim} \eta_\mu \text{Kos}(\Gamma_R, \mathbb{A}_{\text{cris}}^{(m)}(R_\infty)). \tag{46}$$

Pour cela, on écrit $\mathbb{A}_{\text{cris}}^{(m)}(R_\infty)$ comme une somme $\mathbb{A}_{\text{cris}}^{(m)}(R) \oplus (N_\infty \hat{\otimes}_{\mathbb{A}_{\text{inf}}} \mathbb{A}_{\text{cris}}^{(m)})$ (voir [Česnavičius et Koshikawa 2019, (3.14.5)]) avec $\mu \cdot H^i(\Gamma_R, N_\infty \hat{\otimes}_{\mathbb{A}_{\text{inf}}} \mathbb{A}_{\text{cris}}^{(m)}) = 0$ (voir [Česnavičius et Koshikawa 2019, Proposition 3.32]).

Finalement, le quasi-isomorphisme γ^{CK} est donné par la composée

$$\begin{aligned} R\Gamma_{\text{cris}}((\mathfrak{X}_{\mathcal{O}_C}/p)/\mathbb{A}_{\text{cris}}) &\xrightarrow{\sim} \left(\varinjlim_m \text{Kos}(\partial, \mathbb{A}_{\text{cris}}^{(m)}(R)) \right)^\wedge \\ &\xrightarrow[\sim]{\tilde{\beta}} \left(\varinjlim_m \eta_\mu \text{Kos}(\Gamma_R, \mathbb{A}_{\text{cris}}^{(m)}(R)) \right)^\wedge \\ &\xrightarrow{\sim} \left(\varinjlim_m \eta_\mu \text{Kos}(\Gamma_R, \mathbb{A}_{\text{cris}}^{(m)}(R_\infty)) \right)^\wedge \\ &\xrightarrow[\sim]{9.6} R\Gamma_{\text{ét}}(\mathfrak{X}_{\mathcal{O}_C}, A\Omega_{\mathfrak{X}_{\mathcal{O}_C}}) \hat{\otimes}_{\mathbb{A}_{\text{inf}}}^L \mathbb{A}_{\text{cris}}. \quad \square \end{aligned}$$

9B2. Application globale. Comme précédemment, on va écrire les complexes du théorème 9.7 de manière fonctorielle. On commence par le complexe de droite. On prend (Σ, Λ) comme en (27) et on définit $\Gamma_{\Sigma, \Lambda}$, $R_{\Sigma, \Lambda, \infty}^\square$ et $R_{\Sigma, \Lambda, \infty}$ comme avant. On a alors un recouvrement pro-étale affinoïde perfectoïde

$$\text{Spa}\left(R_{\Sigma, \Lambda, \infty} \left[\frac{1}{p} \right], R_{\Sigma, \Lambda, \infty}\right) \rightarrow \text{Spa}\left(R \left[\frac{1}{p} \right], R\right). \tag{47}$$

Le raisonnement précédent (et en particulier l'isomorphisme (43)) donne un quasi-isomorphisme

$$R\Gamma_{\text{ét}}(\mathfrak{X}_{\mathcal{O}_C}, A\Omega_{\mathfrak{X}_{\mathcal{O}_C}}) \widehat{\otimes}_{\mathbb{A}_{\text{inf}}}^L \mathbb{A}_{\text{cris}} \xrightarrow{\sim} \left(\varinjlim_m \eta_\mu \text{Kos}(\Gamma_R, \mathbb{A}_{\text{cris}}^{(m)}(R_{\Sigma, \Lambda, \infty})) \right)^\wedge. \quad (48)$$

On va maintenant écrire le complexe $\Omega_{R_{\Sigma, \Lambda}^{PD}/\mathbb{A}_{\text{cris}}}$ sous une forme semblable à celle de (48). On considère l'exactification de l'immersion $\text{Spec}(R/p) \hookrightarrow \text{Spf}(\mathbb{A}_{\text{cris}}(R_{\Sigma, \Lambda}^\square))$,

$$\text{Spec}(R/p) \xrightarrow{j} \mathcal{Y} \xrightarrow{q} \text{Spf}(\mathbb{A}_{\text{cris}}(R_{\Sigma, \Lambda}^\square)),$$

avec j immersion fermée exacte et q log-étale ; voir [Česnavičius et Koshikawa 2019, §5.25–5.31]. Si on note D_j la log-PD-enveloppe associée à j , on a alors un isomorphisme $R_{\Sigma, \Lambda}^{PD} \xrightarrow{\sim} \widehat{D}_j$. On note $D_j^{(m)}$ l'anneau des puissances divisées de degré inférieur à m et $R_{\Sigma, \Lambda}^{PD, (m)}$ la complétion de l'image de $D_j^{(m)}$ par cet isomorphisme.

Les $R_{\Sigma, \Lambda}^{PD, (m)}$ sont alors des $\mathbb{A}_{\text{cris}}^{(m)}$ -algèbres munies d'une action continue de $\Gamma_{\Sigma, \Lambda}$ et d'un Frobenius. On a de plus un \mathbb{A}_{cris} -isomorphisme $R_{\Sigma, \Lambda}^{PD} \cong \left(\varinjlim_m R_{\Sigma, \Lambda}^{PD, (m)} \right)^\wedge$, qui est équivariant pour l'action du Frobenius et de $\Gamma_{\Sigma, \Lambda}$. On obtient

$$R\Gamma_{\text{cris}}((\mathfrak{X}_{\mathcal{O}_C}/p)/\mathbb{A}_{\text{cris}}) \xrightarrow{\sim} \left(\varinjlim_m \text{Kos}(\partial, R_{\Sigma, \Lambda}^{PD, (m)}) \right)^\wedge. \quad (49)$$

Enfin, en se ramenant au cas où on ne considère qu'une seule coordonnée λ (donnée par le théorème 9.7), on construit un isomorphisme fonctoriel

$$\tilde{\beta}_{\Sigma, \Lambda} : \left(\varinjlim_m \text{Kos}(\partial, R_{\Sigma, \Lambda}^{PD, (m)}) \right)^\wedge \xrightarrow{\sim} \left(\varinjlim_m \eta_\mu \text{Kos}(\Gamma_{\Sigma, \Lambda}, \mathbb{A}_{\text{cris}}^{(m)}(R_{\Sigma, \Lambda, \infty})) \right)^\wedge, \quad (50)$$

voir [Česnavičius et Koshikawa 2019, §5.38–5.39].

On peut maintenant prouver la version globale du théorème 9.7 :

Théorème 9.8 [Česnavičius et Koshikawa 2019, Corollary 5.43]. *Soit \mathfrak{X} un schéma formel propre sur \mathcal{O}_K à réduction semi-stable. Il existe un quasi-isomorphisme compatible avec le morphisme de Frobenius*

$$\gamma^{\text{CK}} : R\Gamma_{\text{cris}}((\mathfrak{X}_{\mathcal{O}_C}/p)/\mathbb{A}_{\text{cris}}) \xrightarrow{\sim} R\Gamma_{\text{ét}}(\mathfrak{X}_{\mathcal{O}_C}, A\Omega_{\mathfrak{X}_{\mathcal{O}_C}}) \widehat{\otimes}_{\mathbb{A}_{\text{inf}}}^L \mathbb{A}_{\text{cris}}.$$

Démonstration. La preuve est similaire à celle du théorème 8.1. Le morphisme global γ^{CK} est donné par la composée

$$\begin{aligned} R\Gamma_{\text{cris}}((\mathfrak{X}_{\mathcal{O}_C}/p)/\mathbb{A}_{\text{cris}}) &\xrightarrow{\sim} \text{hocolim}_{\text{HRF}} R\Gamma_{\text{cris}}((\mathfrak{Y}_{\mathcal{O}_C}^\bullet/p)/\mathbb{A}_{\text{cris}}) \\ &\xrightarrow{\sim} \text{hocolim}_{\text{HRF}} R\Gamma_{\text{ét}}(\mathfrak{Y}_{\mathcal{O}_C}^\bullet, A\Omega_{\mathfrak{Y}_{\mathcal{O}_C}^\bullet}) \\ &\xleftarrow{\sim} R\Gamma_{\text{ét}}(\mathfrak{X}_{\mathcal{O}_C}, A\Omega_{\mathfrak{X}_{\mathcal{O}_C}}), \end{aligned}$$

où, si $\mathcal{U}^\bullet \rightarrow \mathfrak{X}$ est un hyper-recouvrement affine de \mathfrak{X} avec $\mathcal{U}_{\mathcal{O}_C}^k := \mathrm{Spf}(R^k)$, le quasi-isomorphisme $R\Gamma_{\mathrm{cris}}((\mathcal{U}_{\mathcal{O}_C}^\bullet/p)/\mathbb{A}_{\mathrm{cris}}) \xrightarrow{\sim} R\Gamma_{\mathrm{ét}}(\mathcal{U}_{\mathcal{O}_C}^\bullet, A\Omega_{\mathcal{U}_{\mathcal{O}_C}^\bullet})$ est induit par

$$\begin{aligned} R\Gamma_{\mathrm{cris}}((R^k/p)/\mathbb{A}_{\mathrm{cris}}) &\xrightarrow[(49)]{\sim} \varinjlim_{(\Sigma_k, \Lambda_k)} \left(\varinjlim_m \mathrm{Kos}(\partial, R_{\Sigma_k, \Lambda_k}^{PD, (m)}) \right)^\wedge \\ &\xrightarrow[(50)]{\sim} \varinjlim_{(\Sigma_k, \Lambda_k)} \left(\varinjlim_m \eta_\mu \mathrm{Kos}(\Gamma_{\Sigma, \Lambda}, \mathbb{A}_{\mathrm{cris}}^{(m)}(R_{\Sigma, \Lambda, \infty})) \right)^\wedge \\ &\xleftarrow[(48)]{\sim} R\Gamma_{\mathrm{ét}}(\mathfrak{X}_{\mathcal{O}_C}, A\Omega_{\mathfrak{X}_{\mathcal{O}_C}}) \hat{\otimes}_{\mathbb{A}_{\mathrm{inf}}}^L \mathbb{A}_{\mathrm{cris}}. \end{aligned} \quad \square$$

On a un quasi-isomorphisme qui dépend du choix de ϖ et est compatible avec les actions du Frobenius et de l'opérateur de monodromie [Česnavičius et Koshikawa 2019, Proposition 9.2],

$$\iota_{\mathrm{cris}, \varpi}^B : R\Gamma_{\mathrm{cris}}(\mathfrak{X}_k/W(k)^0) \otimes_{W(k)}^L \mathbb{B}_{\mathrm{st}}^+ \xrightarrow{\sim} R\Gamma_{\mathrm{cris}}((\mathfrak{X}_{\mathcal{O}_C}/p)/\mathbb{A}_{\mathrm{cris}}) \otimes_{\mathbb{A}_{\mathrm{cris}}}^L \mathbb{B}_{\mathrm{st}}^+, \quad (51)$$

et on en déduit l'isomorphisme de périodes $\tilde{\alpha}^{\mathrm{CK}}$:

Théorème 9.9 [Česnavičius et Koshikawa 2019, Theorem 9.5]. *Soit \mathfrak{X} un schéma formel propre sur \mathcal{O}_K à réduction semi-stable. Il existe un quasi-isomorphisme*

$$\tilde{\alpha}^{\mathrm{CK}} : R\Gamma_{\mathrm{ét}}(\mathfrak{X}_C, \mathbb{Z}_p) \otimes_{\mathbb{Z}_p}^L \mathbb{B}_{\mathrm{st}} \xrightarrow{\sim} R\Gamma_{\mathrm{cris}}(\mathfrak{X}_k/W(k)^0) \otimes_{W(k)}^L \mathbb{B}_{\mathrm{st}}.$$

De plus, $\tilde{\alpha}^{\mathrm{CK}}$ est compatible avec les actions du morphisme de Frobenius, du groupe de Galois et de l'opérateur de monodromie et il induit un isomorphisme filtré après tensorisation par \mathbb{B}_{dR} .

Démonstration. Le morphisme $\tilde{\alpha}^{\mathrm{CK}}$ est donné par la composée

$$\begin{aligned} R\Gamma_{\mathrm{ét}}(\mathfrak{X}_C, \mathbb{Z}_p) \otimes_{\mathbb{Z}_p}^L \mathbb{B}_{\mathrm{st}} &\xrightarrow[9.4]{\sim} R\Gamma_{\mathrm{ét}}(\mathfrak{X}_{\mathcal{O}_C}, A\Omega_{\mathfrak{X}_{\mathcal{O}_C}}) \otimes_{\mathbb{A}_{\mathrm{inf}}}^L \mathbb{B}_{\mathrm{st}} \\ &\xleftarrow{\gamma^{\mathrm{CK}}} R\Gamma_{\mathrm{cris}}((\mathfrak{X}_{\mathcal{O}_C}/p)/\mathbb{A}_{\mathrm{cris}}) \otimes_{\mathbb{A}_{\mathrm{cris}}}^L \mathbb{B}_{\mathrm{st}} \\ &\xleftarrow[\sim]{\iota_{\mathrm{cris}, \varpi}^B} R\Gamma_{\mathrm{cris}}(\mathfrak{X}_k/W(k)^0) \otimes_{W(k)}^L \mathbb{B}_{\mathrm{st}}. \end{aligned} \quad \square$$

En inversant p , on obtient un quasi-isomorphisme rationnel

$$\tilde{\alpha}^{\mathrm{CK}} : R\Gamma_{\mathrm{ét}}(\mathfrak{X}_C, \mathbb{Q}_p) \otimes_{\mathbb{Q}_p}^L \mathbb{B}_{\mathrm{st}} \xrightarrow{\sim} R\Gamma_{\mathrm{HK}}(\mathfrak{X}) \otimes_F^L \mathbb{B}_{\mathrm{st}}.$$

9B3. Comparaison avec $\tilde{\alpha}^0$. Soit \mathfrak{X} un schéma formel propre sur \mathcal{O}_K à réduction semi-stable. Le but de cette section est de prouver le théorème suivant :

Théorème 9.10. *Les morphismes de périodes*

$$\begin{aligned} \tilde{\alpha}^{\mathrm{CK}}, \tilde{\alpha}^0 &: H_{\mathrm{ét}}^i(\mathfrak{X}_C, \mathbb{Q}_p) \otimes_{\mathbb{Q}_p} \mathbb{B}_{\mathrm{st}} \rightarrow H_{\mathrm{HK}}^i(\mathfrak{X}) \otimes_F \mathbb{B}_{\mathrm{st}}, \\ \tilde{\alpha}_{\mathrm{dR}}^{\mathrm{CK}}, \tilde{\alpha}_{\mathrm{dR}}^0 &: H_{\mathrm{ét}}^i(\mathfrak{X}_C, \mathbb{Q}_p) \otimes_{\mathbb{Q}_p} \mathbb{B}_{\mathrm{dR}} \rightarrow H_{\mathrm{HK}}^i(\mathfrak{X}) \otimes_F \mathbb{B}_{\mathrm{dR}} \end{aligned}$$

sont égaux. En particulier, on a $\tilde{\alpha}^{\mathrm{CK}} = \tilde{\alpha}^{\mathrm{FM}}$ et $\tilde{\alpha}_{\mathrm{dR}}^{\mathrm{CK}} = \tilde{\alpha}_{\mathrm{dR}}^{\mathrm{FM}}$.

Démonstration. Soit $r \geq 0$. On rappelle (voir (38)) que le morphisme $\tilde{\alpha}^0$ est donné par la composée

$$\begin{aligned} \tau_{\leq r} R\Gamma_{\text{ét}}(\mathfrak{X}_C, \mathbb{Q}_p) \otimes_{\mathbb{Q}_p}^L \mathbb{B}_{\text{st}} &\xleftarrow{\sim} \tau_{\leq r} R\Gamma_{\text{ét}}(\mathfrak{X}_C, \mathbb{Q}_p(r)) \otimes_{\mathbb{Q}_p}^L \mathbb{B}_{\text{st}}\{r\} \xleftarrow{\sim} \tau_{\leq r} R\Gamma_{\text{syn}}(\mathfrak{X}_{\mathcal{O}_C}, r)_{\mathbb{Q}} \otimes_{\mathbb{Q}_p}^L \mathbb{B}_{\text{st}}\{r\} \\ &\xrightarrow{\text{can}} R\Gamma_{\text{cris}}((\mathfrak{X}_{\mathcal{O}_C}/p)/\mathbb{A}_{\text{cris}})_{\mathbb{Q}} \otimes_{\mathbb{A}_{\text{cris}}[1/p]}^L \mathbb{B}_{\text{st}} \xleftarrow{\sim} \tau_{\leq r} R\Gamma_{\text{HK}}(\mathfrak{X}) \otimes_F^L \mathbb{B}_{\text{st}} \end{aligned}$$

et $\tilde{\alpha}^{\text{CK}}$ par

$$\begin{aligned} R\Gamma_{\text{ét}}(\mathfrak{X}_C, \mathbb{Q}_p) \otimes_{\mathbb{Q}_p}^L \mathbb{B}_{\text{st}} &\xrightarrow{\sim} R\Gamma_{\text{ét}}(\mathfrak{X}_{\mathcal{O}_C}, A\Omega_{\mathfrak{X}_{\mathcal{O}_C}})_{\mathbb{Q}} \otimes_{\mathbb{A}_{\text{inf}}[1/p]}^L \mathbb{B}_{\text{st}} \\ &\xleftarrow{\sim} R\Gamma_{\text{cris}}((\mathfrak{X}_{\mathcal{O}_C}/p)/\mathbb{A}_{\text{cris}})_{\mathbb{Q}} \otimes_{\mathbb{A}_{\text{cris}}[1/p]}^L \mathbb{B}_{\text{st}} \xleftarrow{\sim} R\Gamma_{\text{HK}}(\mathfrak{X}) \otimes_F^L \mathbb{B}_{\text{st}}. \end{aligned}$$

Pour prouver le théorème, il suffit de montrer que pour $r \geq 2d$ où $d = \dim(X)$, le rectangle extérieur du diagramme suivant commute (au moins au niveau des cohomologies) :

$$\begin{array}{ccccc} \tau_{\leq r} R\Gamma_{\text{ét}}(\mathfrak{X}_C, \mathbb{Q}_p) \otimes_{\mathbb{Q}_p}^L \mathbb{B}_{\text{st}} & \xleftarrow{\sim} & \tau_{\leq r} R\Gamma_{\text{ét}}(\mathfrak{X}_C, \mathbb{Q}_p(r)) \otimes_{\mathbb{Q}_p}^L \mathbb{B}_{\text{st}}\{r\} & \xleftarrow{\sim} & \tau_{\leq r} R\Gamma_{\text{syn}}(\mathfrak{X}_{\mathcal{O}_C}, r)_{\mathbb{Q}} \otimes_{\mathbb{Q}_p}^L \mathbb{B}_{\text{st}}\{r\} \\ \downarrow \scriptstyle{9.4} \wr & \swarrow f_r & & \searrow \text{can} & \downarrow \\ \tau_{\leq r} R\Gamma_{\text{ét}}(\mathfrak{X}_{\mathcal{O}_C}, A\Omega_{\mathfrak{X}_{\mathcal{O}_C}})_{\mathbb{Q}} \otimes_{\mathbb{A}_{\text{inf}}[1/p]}^L \mathbb{B}_{\text{st}} & \xleftarrow{\sim} & \tau_{\leq r} R\Gamma_{\text{cris}}((\mathfrak{X}_{\mathcal{O}_C}/p)/\mathbb{A}_{\text{cris}})_{\mathbb{Q}} \otimes_{\mathbb{A}_{\text{cris}}[1/p]}^L \mathbb{B}_{\text{st}} & \xleftarrow{\sim} & \tau_{\leq r} R\Gamma_{\text{HK}}(\mathfrak{X}) \otimes_F^L \mathbb{B}_{\text{st}} \end{array}$$

L'application f_r est définie de façon à ce que le triangle de gauche soit commutatif. Le triangle de droite est commutatif par [Nekovář et Nizioł 2016, §3.1], il suffit donc de montrer que le trapèze intérieur commute. Il est suffisant de le montrer au niveau des cohomologies et c'est le résultat du lemme 9.11 ci-dessous. \square

Lemme 9.11. Soit $i \leq r$. Le diagramme suivant est commutatif :

$$\begin{array}{ccc} H_{\text{ét}}^i(\mathfrak{X}_{\mathcal{O}_C}, A\Omega_{\mathfrak{X}_{\mathcal{O}_C}})_{\mathbb{Q}} \otimes_{\mathbb{A}_{\text{inf}}[1/p]}^L \mathbb{B}_{\text{st}} & \xleftarrow{\sim} & H_{\text{cris}}^i((\mathfrak{X}_{\mathcal{O}_C}/p)/\mathbb{A}_{\text{cris}})_{\mathbb{Q}} \otimes_{\mathbb{A}_{\text{cris}}[1/p]}^L \mathbb{B}_{\text{st}} \\ f_r \uparrow & & \text{can} \uparrow \\ H_{\text{ét}}^i(\mathfrak{X}_C, \mathbb{Q}_p(r)) \otimes_{\mathbb{Q}_p}^L \mathbb{B}_{\text{st}}\{r\} & \xleftarrow{\sim} & H_{\text{syn}}^i(\mathfrak{X}_{\mathcal{O}_C}, r)_{\mathbb{Q}} \otimes_{\mathbb{Q}_p}^L \mathbb{B}_{\text{st}}\{r\} \end{array}$$

Démonstration. (i) *Réduction.* Pour prouver le lemme, par $\mathbb{B}_{\text{cris}}^+[1/\mu]$ -linéarité, il suffit de voir que le diagramme suivant est commutatif :

$$\begin{array}{ccc} H_{\text{ét}}^i(\mathfrak{X}_{\mathcal{O}_C}, A\Omega_{\mathfrak{X}_{\mathcal{O}_C}})_{\mathbb{Q}} \otimes_{\mathbb{A}_{\text{inf}}[1/p]}^L \mathbb{B}_{\text{cris}}^+[1/\mu] & \xleftarrow{\sim} & H_{\text{cris}}^i((\mathfrak{X}_{\mathcal{O}_C}/p)/\mathbb{A}_{\text{cris}})_{\mathbb{Q}} \otimes_{\mathbb{A}_{\text{cris}}[1/p]}^L \mathbb{B}_{\text{cris}}^+[1/\mu] \\ f_r \uparrow & & \text{can} \uparrow \\ H_{\text{ét}}^i(\mathfrak{X}_C, \mathbb{Q}_p(r)) & \xleftarrow{\sim} & H_{\text{syn}}^i(\mathfrak{X}_{\mathcal{O}_C}, r)_{\mathbb{Q}} \end{array}$$

Considérons le diagramme

$$\begin{array}{ccc}
 H_{\text{ét}}^i(\mathfrak{X}_{\mathcal{O}_C}, A\Omega_{\mathfrak{X}_{\mathcal{O}_C}})_{\mathbb{Q}} \otimes_{\mathbb{A}_{\text{inf}}[\frac{1}{p}]}^L \mathbb{A}^{[u,v]}[\frac{1}{p}, \frac{1}{\mu}] & \xleftarrow[\gamma_{[u,v]}^{\text{CK}}]{\sim} & H_{\text{cris}}^i((\mathfrak{X}_{\mathcal{O}_C}/p)/\mathbb{A}_{\text{cris}})_{\mathbb{Q}} \otimes_{\mathbb{A}_{\text{cris}}[\frac{1}{p}]}^L \mathbb{A}^{[u,v]}[\frac{1}{p}, \frac{1}{\mu}] \\
 \text{Id} \otimes \text{can} \uparrow & & \text{Id} \otimes \text{can} \uparrow \\
 H_{\text{ét}}^i(\mathfrak{X}_{\mathcal{O}_C}, A\Omega_{\mathfrak{X}_{\mathcal{O}_C}})_{\mathbb{Q}} \otimes_{\mathbb{A}_{\text{inf}}[\frac{1}{p}]}^L \mathbb{A}_{\text{cris}}[\frac{1}{p}, \frac{1}{\mu}] & \xleftarrow[\gamma^{\text{CK}}]{\sim} & H_{\text{cris}}^i((\mathfrak{X}_{\mathcal{O}_C}/p)/\mathbb{A}_{\text{cris}})_{\mathbb{Q}} \otimes_{\mathbb{A}_{\text{cris}}[\frac{1}{p}]}^L \mathbb{A}_{\text{cris}}[\frac{1}{p}, \frac{1}{\mu}] \quad (52) \\
 f_r \uparrow & & \text{can} \uparrow \\
 H_{\text{ét}}^i(\mathfrak{X}_C, \mathbb{Q}_p(r)) & \xleftarrow[\alpha_r^0]{\sim} & H_{\text{syn}}^i(\mathfrak{X}_{\mathcal{O}_C}, r)_{\mathbb{Q}}
 \end{array}$$

La flèche verticale de gauche $\beta_1 := \text{Id} \otimes \text{can}$ est injective. En effet, par le [théorème 9.4](#), on a

$$H_{\text{ét}}^i(\mathfrak{X}_{\mathcal{O}_C}, A\Omega_{\mathfrak{X}_{\mathcal{O}_C}})_{\mathbb{Q}} \otimes_{\mathbb{A}_{\text{inf}}[1/p]}^L \mathbb{A}_{\text{inf}}[\frac{1}{p}, \frac{1}{\mu}] \xleftarrow{\sim} H_{\text{ét}}^i(\mathfrak{X}_C, \mathbb{Q}_p(r)) \otimes_{\mathbb{Q}_p}^L \mathbb{A}_{\text{inf}}[\frac{1}{p}, \frac{1}{\mu}],$$

et on en déduit les isomorphismes

$$\begin{aligned}
 H_{\text{ét}}^i(\mathfrak{X}_{\mathcal{O}_C}, A\Omega_{\mathfrak{X}_{\mathcal{O}_C}})_{\mathbb{Q}} \otimes_{\mathbb{A}_{\text{inf}}[1/p]}^L \mathbb{A}^{[u,v]}[\frac{1}{p}, \frac{1}{\mu}] &\xleftarrow{\sim} H_{\text{ét}}^i(\mathfrak{X}_C, \mathbb{Q}_p(r)) \otimes_{\mathbb{Q}_p}^L \mathbb{A}^{[u,v]}[\frac{1}{p}, \frac{1}{\mu}], \\
 H_{\text{ét}}^i(\mathfrak{X}_{\mathcal{O}_C}, A\Omega_{\mathfrak{X}_{\mathcal{O}_C}})_{\mathbb{Q}} \otimes_{\mathbb{A}_{\text{inf}}[1/p]}^L \mathbb{A}_{\text{cris}}[\frac{1}{p}, \frac{1}{\mu}] &\xleftarrow{\sim} H_{\text{ét}}^i(\mathfrak{X}_C, \mathbb{Q}_p(r)) \otimes_{\mathbb{Q}_p}^L \mathbb{A}_{\text{cris}}[\frac{1}{p}, \frac{1}{\mu}].
 \end{aligned}$$

En utilisant que l'application canonique $\mathbb{A}_{\text{cris}}[1/p, 1/\mu] \rightarrow \mathbb{A}^{[u,v]}[1/p, 1/\mu]$ est injective et $H_{\text{ét}}^i(\mathfrak{X}_C, \mathbb{Q}_p(r))$ est de rang fini sur \mathbb{Q}_p , on obtient que β_1 est injective.

On en déduit que pour prouver le lemme, il suffit de montrer que le carré extérieur du diagramme (52) commute. Mais en utilisant une nouvelle fois le [théorème 9.4](#) puis le [théorème 9.8](#) (et que $H_{\text{ét}}^i(\mathfrak{X}_C, \mathbb{Q}_p(r))$ est de \mathbb{Q}_p -rang fini), on a

$$\begin{aligned}
 H_{\text{ét}}^i(\mathfrak{X}_{\mathcal{O}_C}, A\Omega_{\mathfrak{X}_{\mathcal{O}_C}})_{\mathbb{Q}} \otimes_{\mathbb{A}_{\text{inf}}[1/p]}^L \mathbb{A}^{[u,v]}[\frac{1}{p}, \frac{1}{\mu}] &\xrightarrow{\sim} H_{\text{ét}}^i\left(R\Gamma(\mathfrak{X}_{\mathcal{O}_C}, A\Omega_{\mathfrak{X}_{\mathcal{O}_C}}) \otimes_{\mathbb{A}_{\text{inf}}[1/p]}^L \mathbb{A}^{[u,v]}[\frac{1}{p}, \frac{1}{\mu}]\right), \\
 H_{\text{cris}}^i((\mathfrak{X}_{\mathcal{O}_C}/p)/\mathbb{A}_{\text{cris}})_{\mathbb{Q}} \otimes_{\mathbb{A}_{\text{cris}}[1/p]}^L \mathbb{A}^{[u,v]}[\frac{1}{p}, \frac{1}{\mu}] & \\
 &\xrightarrow{\sim} H^i\left(R\Gamma_{\text{cris}}((\mathfrak{X}_{\mathcal{O}_C}/p)/\mathbb{A}_{\text{cris}})_{\mathbb{Q}} \otimes_{\mathbb{A}_{\text{cris}}[1/p]}^L \mathbb{A}^{[u,v]}[\frac{1}{p}, \frac{1}{\mu}]\right),
 \end{aligned}$$

et il suffit donc de montrer que le diagramme

$$\begin{array}{ccc}
 \tau_{\leq r} R\Gamma_{\text{ét}}(\mathfrak{X}_{\mathcal{O}_C}, A\Omega_{\mathfrak{X}_{\mathcal{O}_C}})_{\mathbb{Q}} \otimes_{\mathbb{A}_{\text{inf}}[\frac{1}{p}]}^L \mathbb{A}^{[u,v]}[\frac{1}{p}, \frac{1}{\mu}] & \xleftarrow[\gamma_{[u,v]}^{\text{CK}}]{\sim} & \tau_{\leq r} R\Gamma_{\text{cris}}((\mathfrak{X}_{\mathcal{O}_C}/p)/\mathbb{A}_{\text{cris}})_{\mathbb{Q}} \otimes_{\mathbb{A}_{\text{cris}}[\frac{1}{p}]}^L \mathbb{A}^{[u,v]}[\frac{1}{p}, \frac{1}{\mu}] \\
 f_r \uparrow & & \text{can} \uparrow \\
 \tau_{\leq r} R\Gamma_{\text{ét}}(\mathfrak{X}_C, \mathbb{Q}_p(r)) & \xleftarrow[\alpha_r^0]{\sim} & \tau_{\leq r} R\Gamma_{\text{syn}}(\mathfrak{X}_{\mathcal{O}_C}, r)_{\mathbb{Q}} \quad (53)
 \end{array}$$

commute.

Pour cela, on va montrer que le diagramme suivant est p^N -commutatif (pour un $N \in \mathbb{N}$) :

$$\begin{array}{ccc}
 \tau_{\leq r} R\Gamma_{\text{ét}}(\mathfrak{X}_{\mathcal{O}_C}, A\Omega_{\mathfrak{X}_{\mathcal{O}_C}}) \widehat{\otimes}_{\mathbb{A}_{\text{inf}}}^L \mathbb{A}^{[u,v]} \left[\frac{1}{\mu} \right] & \xleftarrow[\gamma_{[u,v]}^{\text{CK}}]{\sim} & \tau_{\leq r} R\Gamma_{\text{cris}}((\mathfrak{X}_{\mathcal{O}_C}/p)/\mathbb{A}_{\text{cris}}) \widehat{\otimes}_{\mathbb{A}_{\text{cris}}}^L \mathbb{A}^{[u,v]} \left[\frac{1}{\mu} \right] \\
 \uparrow f_r & & \uparrow \text{can} \\
 \tau_{\leq r} R\Gamma_{\text{ét}}(\mathfrak{X}_C, \mathbb{Z}_p(r)) & \xleftarrow[\alpha_r^0]{\sim} & \tau_{\leq r} R\Gamma_{\text{syn}}(\mathfrak{X}_{\mathcal{O}_C}, r)
 \end{array} \tag{54}$$

(ii) *Calcul local.* On suppose dans un premier temps que $\mathfrak{X} = \text{Spf}(R)$ avec R la complétion d'une algèbre étale sur R_{\square} . On va voir que la principale différence entre la construction du morphisme de [Česnavičius et Koshikawa 2019] et celle de α_r^0 est que l'application $\tilde{\beta}$ utilisée par Bhatt et al. est égale à l'inverse de l'application β construite plus haut, tordue par t . Plus précisément, on va montrer qu'on a un diagramme $p^{c(r)}$ -commutatif (pour une certaine constante $c(r) \in \mathbb{N}$) :

$$\begin{array}{ccccccc}
 & & & & & & \gamma_{[u,v]}^{\text{CK}} \\
 & & & & & & \nearrow \\
 K_{\varphi, \partial}(F^r \mathbb{A}_{\text{cris}}(R)) & & & & & & \\
 \downarrow & & & & & & \searrow \\
 K_{\partial}(\mathbb{A}_{\text{cris}}(R))^{[u,v]} & \xrightarrow{\tilde{\beta}} & (\eta_{\mu} \tilde{K}_{\Gamma}(\mathbb{A}_{\text{cris}}(R)))^{[u,v]} & \xrightarrow{(46)} & (\eta_{\mu} \tilde{K}_{\Gamma}(\mathbb{A}_{\text{cris}}(R_{\infty})))^{[u,v]} & \xrightarrow{(44)} & \eta_{\mu}(K_{\Gamma}(\mathbb{A}_{R_{\infty}}^+)^{[u,v]}) & \xrightarrow{\tilde{\mu}_H} & \eta_{\mu}(C_G(\mathbb{A}_{R_{\infty}}^+)^{[u,v]}) \\
 \downarrow & & \downarrow & & \downarrow & & \downarrow & & \downarrow \\
 K_{\partial}(\mathbb{A}_R^{[u,v]}) & \xrightarrow{\tilde{\beta}} & \eta_{\mu} K_{\Gamma}(\mathbb{A}_R^{[u,v]}) & \longrightarrow & \eta_{\mu} K_{\Gamma}(\mathbb{A}_{R_{\infty}}^{[u,v]}) & \xrightarrow{\tilde{\mu}_H} & \eta_{\mu} C_G(\mathbb{A}_R^{[u,v]}) & & \\
 \uparrow & & \uparrow & & \uparrow & & \uparrow & & \uparrow \\
 K_{\partial}(F^r \mathbb{A}_R^{[u,v]}) & \xrightarrow{\beta'_1} & K_{\Gamma}(\mathbb{A}_R^{[u,v]}(r)) & \longrightarrow & K_{\Gamma}(\mathbb{A}_{R_{\infty}}^{[u,v]}(r)) & \xrightarrow{\tilde{\mu}_H} & C_G(\mathbb{A}_R^{[u,v]}(r)) & & \\
 \uparrow & & \uparrow & & \uparrow & & \uparrow & & \uparrow \\
 K_{\varphi, \partial}(F^r \mathbb{A}_R^{[u,v]}) & \xrightarrow{\beta'} & K_{\varphi, \Gamma}(\mathbb{A}_R^{[u,v]}(r)) & \longrightarrow & K_{\varphi, \Gamma}(\mathbb{A}_{R_{\infty}}^{[u,v]}(r)) & \xrightarrow{\tilde{\mu}_H} & C_{G, \varphi}(\mathbb{A}_R^{[u,v]}(r)) & & \\
 \uparrow & & \uparrow & & \uparrow & & \uparrow & & \uparrow \\
 & & K_{\varphi, \Gamma}(\mathbb{A}_R^{(0, v]+}(r)) & \longrightarrow & K_{\varphi, \Gamma}(\mathbb{A}_{R_{\infty}}^{(0, v]+}(r)) & \xrightarrow{\tilde{\mu}_H} & C_{G, \varphi}(\mathbb{A}_R^{(0, v]+}(r)) & & \\
 \uparrow & & \uparrow & & \uparrow & & \uparrow & & \uparrow \\
 & & K_{\varphi, \Gamma}(\mathbb{A}_R(r)) & \xrightarrow{6.3} & K_{\varphi, \Gamma}(\mathbb{A}_{R_{\infty}}(r)) & \xrightarrow{6.2} & C_{G, \varphi}(\mathbb{A}_R(r)) & \xleftarrow{\sim} & C_G(\mathbb{Z}_p(r))
 \end{array} \tag{55}$$

Tous les complexes sont tronqués par $\tau_{\leq r}$. L'exposant $[u, v]$ sur la deuxième ligne sert à désigner $(-)\widehat{\otimes}_{\mathbb{A}_{\text{inf}}}^L \mathbb{A}^{[u,v]}$. On pose $K_{\Gamma}(-) := \text{Kos}(\Gamma, -)$, $K_{\partial}(-) := \text{Kos}(\partial, -)$ et $C_G(-)$ désigne le complexe de cochaînes continues de G . Les notations $K_{\varphi, \Gamma}$ et $C_{G, \varphi}(-)$ sont celles du théorème 7.5. On écrit $\eta_{\mu} \tilde{K}_{\Gamma}(\mathbb{A}_{\text{cris}}(R)) := \varinjlim \eta_{\mu} K_{\Gamma}(\mathbb{A}_{\text{cris}}^{(m)}(R))$ et $\eta_{\mu} \tilde{K}_{\Gamma}(\mathbb{A}_{\text{cris}}(R_{\infty})) := \varinjlim \eta_{\mu} K_{\Gamma}(\mathbb{A}_{\text{cris}}^{(m)}(R_{\infty}))$. Enfin, les morphismes $\tilde{\mu}_H$ sont ceux induits par les morphismes

$$\text{Kos}(\Gamma_R, \mathbb{A}_{R_{\infty}}^?) \rightarrow C(\Gamma_R, \mathbb{A}_{R_{\infty}}^?) \rightarrow C(G_R, \mathbb{A}_R^?)$$

pour $? \in \{(0, v]+, [u, v]\}$, où la deuxième flèche est le morphisme de bord du recouvrement de Galois R_{∞} de R .

L'application β' est donnée par la composée

$$\tau_{\leq r} \text{Kos}(\partial, \varphi, F^r \mathbb{A}_R^{[u,v]}) \xrightarrow{t^\bullet} \tau_{\leq r} \text{Kos}(\text{Lie } \Gamma, \varphi, F^r \mathbb{A}_R^{[u,v]}) \leftarrow \tau_{\leq r} \text{Kos}(\text{Lie } \Gamma, \varphi, \mathbb{A}_R^{[u,v]}(r)) \xleftarrow{\beta} \tau_{\leq r} \text{Kos}(\Gamma, \varphi, \mathbb{A}_R^{[u,v]}(r))$$

où la seconde flèche est donnée par

$$\begin{array}{ccc} \text{Kos}(\text{Lie } \Gamma_R, \mathbb{A}_R^{[u,v]}(r)) & \xrightarrow{1-\varphi} & \text{Kos}(\text{Lie } \Gamma_R, \mathbb{A}_R^{[u,v/p]}(r)) \\ \downarrow & & \downarrow p^r \\ \text{Kos}(\text{Lie } \Gamma_R, \mathbb{A}_R^{[u,v]}(r)) & \xrightarrow{p^r(1-\varphi)} & \text{Kos}(\text{Lie } \Gamma_R, \mathbb{A}_R^{[u,v/p]}(r)) \\ \downarrow t^r & & \downarrow t^r \\ \text{Kos}(\text{Lie } \Gamma_R, F^r \mathbb{A}_R^{[u,v]}) & \xrightarrow{p^r-\varphi} & \text{Kos}(\text{Lie } \Gamma_R, \mathbb{A}_R^{[u,v/p]}) \end{array}$$

et où

$$\beta : \mathbb{A}_R^{[u,v]}(r)^{J_j} \rightarrow \mathbb{A}_R^{[u,v]}(r)^{J_j}, \quad (a_{i_1 \dots i_j}) \mapsto (\beta_{i_j} \dots \beta_{i_1}(a_{i_1 \dots i_j})) \quad \text{avec } \beta_k := \sum_{n \geq 1} \frac{(-1)^{n-1}}{n} \tau_k^{n-1}.$$

En particulier, sur le premier terme, β' induit

$$\beta'_1 : \tau_{\leq r} \text{Kos}(\partial, F^r \mathbb{A}_R^{[u,v]}) \xrightarrow{t^\bullet} \tau_{\leq r} \text{Kos}(\text{Lie } \Gamma, F^r \mathbb{A}_R^{[u,v]}) \xleftarrow{t^r} \tau_{\leq r} \text{Kos}(\text{Lie } \Gamma, \mathbb{A}_R^{[u,v]}(r)) \xleftarrow{\beta} \tau_{\leq r} \text{Kos}(\Gamma, \mathbb{A}_R^{[u,v]}(r)). \quad (56)$$

Les deux premières flèches sont des $p^{c(r)}$ -quasi-isomorphismes (pour certaines constantes $c(r)$) et l'application β est un isomorphisme.

L'application $\tilde{\beta}^{(m)} : (\mathbb{A}_{\text{cris}}^{(m)}(R))^{J_i} \rightarrow (\mathbb{A}_{\text{cris}}^{(m)}(R))^{J_i}$ est donnée par les $\tilde{\beta}_k = \sum_{n \geq 1} (t^n/n!) \partial_k^{n-1}$. Soit $(a_{i_1 \dots i_j})$ dans $(F^{r-j} \mathbb{A}_R^{[u,v]})^{J_j}$, on a alors

$$t^r \beta'((a_{i_1 \dots i_j})) = (t^r \beta_{i_1}^{-1} \dots \beta_{i_j}^{-1}(t^{j-r} a_{i_1 \dots i_j})) = ((\beta_{i_1}^{-1} t) \dots (\beta_{i_j}^{-1} t)(a_{i_1 \dots i_j}))$$

et $(\beta_{i_k}^{-1} t) = (\sum_{n \geq 0} b_n \tau_{i_k}^n) t$ où les b_n sont les coefficients de la série $X/\log(1+X)$. Comme

$$\tilde{\beta}_{i_k} = \sum_{n \geq 1} \frac{t^n}{n!} \partial_{i_k}^{n-1} = \left(\sum_{n \geq 1} \frac{1}{n!} (t \partial_{i_k})^{n-1} \right) t$$

avec $(t \partial_{i_k}) = \log(\gamma_{i_k})$, on obtient $\beta_{i_k}^{-1} t = \tilde{\beta}_{i_k}$ et on en déduit que le carré

$$\begin{array}{ccc} K_{\partial}(\mathbb{A}_R^{[u,v]}) & \xrightarrow{\tilde{\beta}} & \eta_{\mu} K_{\Gamma}(\mathbb{A}_R^{[u,v]}) \\ \uparrow & & \uparrow t^r \\ K_{\partial}(F^r \mathbb{A}_R^{[u,v]}) & \xrightarrow{\beta'_1} & K_{\Gamma}(\mathbb{A}_R^{[u,v]}(r)) \end{array} \quad (57)$$

commute, où β'_1 est l'application donnée par (56). On obtient finalement que le diagramme (55) est $p^{c(r)}$ -commutatif (pour un certain $c(r) \in \mathbb{N}$).

Montrons que le trapèze dans le coin supérieur droit

$$\begin{array}{ccc}
 \eta_\mu K_\Gamma(\mathbb{A}_{R_\infty}^+)[u,v] & \xrightarrow[\sim]{\tilde{\mu}_H} & \eta_\mu C_G(\mathbb{A}_{\bar{R}}^+)[u,v] \\
 \downarrow \wr & \searrow \sim & \downarrow \wr \\
 \eta_\mu K_\Gamma(\mathbb{A}_{R_\infty}^{[u,v]}) & \xrightarrow[\sim]{\tilde{\mu}_H} & \eta_\mu C_G(\mathbb{A}_{\bar{R}}^{[u,v]})
 \end{array} \tag{58}$$

est constitué de quasi-isomorphismes.

La flèche verticale de gauche est un isomorphisme de complexes. La flèche horizontale du haut est un quasi-isomorphisme par (42). Montrons que la flèche verticale de droite est un quasi-isomorphisme. Par définition, le complexe $C_G(\mathbb{A}_{\bar{R}}^+)^{[u,v]}$ est égal à

$$\operatorname{holim}_n((R\Gamma(G, \mathbb{A}_{\bar{R}}^+) \otimes_{\mathbb{A}_{\text{inf}}}^L \mathbb{A}^{[u,v]}) \otimes_{\mathbb{A}_{\text{inf}}}^L \mathbb{A}_{\text{inf}} / (\xi, p)^n).$$

Mais $R\Gamma(G, \mathbb{A}_{\bar{R}}^+)$ est calculé par le complexe borné $\operatorname{Kos}(\Gamma_R, \mathbb{A}_{R_\infty}^+)$ dont les termes sont plats sur \mathbb{A}_{inf} . On a donc

$$R\Gamma(G, \mathbb{A}_{\bar{R}}^+) \otimes_{\mathbb{A}_{\text{inf}}}^L \mathbb{A}^{[u,v]} \cong R\Gamma(G, \mathbb{A}_{\bar{R}}^+) \otimes_{\mathbb{A}_{\text{inf}}} \mathbb{A}^{[u,v]}.$$

Pour n suffisamment grand (tel que $\xi^n \in p\mathbb{A}^{[u,v]}$), on a

$$\operatorname{Tor}_{\mathbb{A}_{\text{inf}}}^1(\mathbb{A}^{[u,v]}, \mathbb{A}_{\text{inf}} / (\xi, p)^n) \hookrightarrow \operatorname{Tor}_{\mathbb{A}_{\text{inf}}}^1(\mathbb{A}^{[u,v]}, \mathbb{A}_{\text{inf}} / p) = 0$$

et donc

$$(R\Gamma(G, \mathbb{A}_{\bar{R}}^+) \otimes_{\mathbb{A}_{\text{inf}}}^L \mathbb{A}^{[u,v]}) \otimes_{\mathbb{A}_{\text{inf}}}^L \mathbb{A}_{\text{inf}} / (\xi, p)^n \cong R\Gamma(G, \mathbb{A}_{\bar{R}}^+) \otimes_{\mathbb{A}_{\text{inf}}} \mathbb{A}^{[u,v]} / (\xi, p)^n.$$

Les termes du complexes ci-dessus sont donnés par

$$\operatorname{Map}_{\text{cont}}(G^m, \mathbb{A}_{\bar{R}}^+) \otimes_{\mathbb{A}_{\text{inf}}} \mathbb{A}^{[u,v]} / (p, \xi)^n,$$

qui est isomorphe à

$$\operatorname{Map}_{\text{cont}}(G^m, \mathbb{A}_{\bar{R}}^+ \otimes_{\mathbb{A}_{\text{inf}}} \mathbb{A}^{[u,v]} / (p, \xi)^n),$$

car G est profini. En prenant la limite sur n , on obtient finalement le quasi-isomorphisme

$$C_G(\mathbb{A}_{\bar{R}}^+)^{[u,v]} \xrightarrow{\sim} C_G(\mathbb{A}_{\bar{R}}^{[u,v]}).$$

On en déduit que les autres flèches de (58) sont elles aussi des quasi-isomorphismes. Finalement, une chasse au diagramme (dans (55)) montre que (54) et donc (53) commute dans le cas où $\mathfrak{X} := \operatorname{Spf}(R)$. Il reste à voir que le résultat reste vrai pour \mathfrak{X} global.

(iii) *Cas global.* Dans un premier temps, on suppose toujours $\mathfrak{X} = \operatorname{Spf}(R)$. Si (Σ, Λ) sont tels qu'on ait une immersion (27), en définissant $R_{\Sigma, \Lambda}^{PD}$, $R_{\infty, \Sigma, \Lambda}$, etc. comme précédemment, on peut réécrire le

diagramme (55) en utilisant les versions (Σ, Λ) des anneaux. On prend ensuite la limite sur l'ensemble des (Σ, Λ) et on obtient un diagramme commutatif fonctoriel

$$\begin{array}{ccc} \varinjlim_{\Sigma, \Lambda} \tau_{\leq r} (\text{Kos}(\partial, R_{\Sigma, \Lambda}^{PD})_{\mathbb{Q}} \widehat{\otimes}_{\mathbb{A}_{\text{cris}}[1/p]}^L \mathbb{A}^{[u, v]}[\frac{1}{p}, \frac{1}{\mu}]) & \xrightarrow{\sim} & \varinjlim_{\Sigma, \Lambda} \tau_{\leq r} (\eta_{\mu} CG(\mathbb{A}_{\Sigma, \Lambda}^{\pm})_{\mathbb{Q}} \widehat{\otimes}_{\mathbb{A}_{\text{inf}}[1/p]}^L \mathbb{A}^{[u, v]}[\frac{1}{p}, \frac{1}{\mu}]) \\ \uparrow & & \uparrow t^r \\ \varinjlim_{\Sigma, \Lambda} \tau_{\leq r} \text{Kos}(\partial, \varphi, F^r R_{\Sigma, \Lambda}^{PD})_{\mathbb{Q}} & \xrightarrow{\sim} & \tau_{\leq r} CG(\text{Kos}(\varphi, \mathbb{A}_{\bar{R}}(r)))_{\mathbb{Q}} \xleftarrow{\sim} \tau_{\leq r} CG(\mathbb{Z}_p(r))_{\mathbb{Q}} \end{array}$$

Soit \mathfrak{X} global. En considérant des hyper-recouvrements affines $\mathfrak{U}^{\bullet} \rightarrow \mathfrak{X}$ comme précédemment et en remarquant que les deux complexes de la ligne du haut du diagramme ci-dessus calculent respectivement

$$\tau_{\leq r} R\Gamma_{\text{cris}}((\mathfrak{U}_{\mathcal{O}_C}^k / p) / \mathbb{A}_{\text{cris}})_{\mathbb{Q}} \widehat{\otimes}_{\mathbb{A}_{\text{cris}}[1/p]}^L \mathbb{A}^{[u, v]}[\frac{1}{p}, \frac{1}{\mu}]$$

et

$$\tau_{\leq r} R\Gamma_{\text{ét}}(\mathfrak{U}_{\mathcal{O}_C}^k, A\Omega_{\mathfrak{X}_{\mathcal{O}_C}})_{\mathbb{Q}} \widehat{\otimes}_{\mathbb{A}_{\text{inf}}[1/p]}^L \mathbb{A}^{[u, v]}[\frac{1}{p}, \frac{1}{\mu}],$$

on en déduit que le diagramme suivant commute :

$$\begin{array}{ccccccc} \tau_{\leq r} R\Gamma_{\text{cris}}(\mathfrak{X})_{\mathbb{Q}}^{[u, v]} & \xrightarrow{\sim} & \tau_{\leq r} \text{hocolim} R\Gamma_{\text{cris}}(\mathfrak{U}^{\bullet})_{\mathbb{Q}}^{[u, v]} & \xrightarrow{\sim} & \tau_{\leq r} \text{hocolim} R\Gamma_{\text{ét}}(A\Omega_{\mathfrak{U}^{\bullet}})_{\mathbb{Q}}^{[u, v]} & \xleftarrow{\sim} & \tau_{\leq r} R\Gamma_{\text{ét}}(A\Omega_{\mathfrak{X}})_{\mathbb{Q}}^{[u, v]} \\ \uparrow & & \uparrow & & \uparrow t^r & & \uparrow t^r \\ \tau_{\leq r} R\Gamma_{\text{syn}}(\mathfrak{X}_{\mathcal{O}_C}, r)_{\mathbb{Q}} & \xrightarrow{\sim} & \tau_{\leq r} \text{hocolim} R\Gamma_{\text{syn}}(\mathfrak{U}_{\mathcal{O}_C}^{\bullet}, r)_{\mathbb{Q}} & \xrightarrow{\sim} & \tau_{\leq r} \text{hocolim} R\Gamma_{\text{ét}}(\mathfrak{U}_{\mathcal{O}_C}^{\bullet}, \mathbb{Q}_p(r)) & \xleftarrow{\sim} & \tau_{\leq r} R\Gamma_{\text{ét}}(\mathfrak{X}_C, \mathbb{Q}_p(r)) \end{array}$$

On a ici noté $R\Gamma_{\text{cris}}(-) := R\Gamma_{\text{cris}}(((-)_{\mathcal{O}_C} / p) / \mathbb{A}_{\text{cris}})$ et $R\Gamma_{\text{ét}}(A\Omega_{(-)_{\mathcal{O}_C}}) := R\Gamma_{\text{ét}}((-)_{\mathcal{O}_C}, A\Omega_{(-)_{\mathcal{O}_C}})$. On obtient le résultat du lemme. □

Remerciements

Cet article présente les résultats obtenus durant ma thèse à l'ÉNS de Lyon. Je remercie ma directrice de thèse, Wiesława Nizioł, pour m'avoir suggéré ce sujet et pour les conseils et l'aide qu'elle m'a apportés tout au long de ce projet. Je remercie également l'évaluateur pour sa lecture attentive et ses nombreuses remarques et corrections.

Ce projet a reçu des financements du Labex Milyon, dans le cadre du programme Investissements d'Avenir (ANR-11-IDEX-0007) et de l'European Research Council (ERC) dans le cadre du programme European Union's Horizon 2020 research and innovation programme (grant agreement No. 804176).

Bibliographie

[Andreatta et Brinon 2008] F. Andreatta et O. Brinon, "Surconvergence des représentations p -adiques: le cas relatif", pp. 39–116 dans *Représentations p -adiques de groupes p -adiques, I : Représentations galoisiennes et (ϕ, Γ) -modules*, Astérisque **319**, Soc. Math. de France, Paris, 2008. [MR](#) [Zbl](#)

[Andreatta et Iovita 2008] F. Andreatta et A. Iovita, "Global applications of relative (ϕ, Γ) -modules, I", pp. 339–420 dans *Représentations p -adiques de groupes p -adiques, I : Représentations galoisiennes et (ϕ, Γ) -modules*, Astérisque **319**, Soc. Math. de France, Paris, 2008. [MR](#) [Zbl](#)

- [Antieau et al. 2022] B. Antieau, A. Mathew, M. Morrow et T. Nikolaus, “On the Beilinson fiber square”, *Duke Math. J.* **171**:18 (2022), 3707–3806. [MR](#) [Zbl](#)
- [Beilinson 2013] A. A. Beilinson, “On the crystalline period map”, *Camb. J. Math.* **1**:1 (2013), 1–51. [MR](#) [Zbl](#)
- [Bhatt et al. 2018] B. Bhatt, M. Morrow et P. Scholze, “Integral p -adic Hodge theory”, *Publ. Math. Inst. Hautes Études Sci.* **128** (2018), 219–397. [MR](#) [Zbl](#)
- [Bloch et Kato 1986] S. Bloch et K. Kato, “ p -adic étale cohomology”, *Inst. Hautes Études Sci. Publ. Math.* **63** (1986), 107–152. [MR](#) [Zbl](#)
- [Česnavičius et Koshikawa 2019] K. Česnavičius et T. Koshikawa, “The A_{inf} -cohomology in the semistable case”, *Compos. Math.* **155**:11 (2019), 2039–2128. [MR](#) [Zbl](#)
- [Colmez 2002] P. Colmez, “Espaces de Banach de dimension finie”, *J. Inst. Math. Jussieu* **1**:3 (2002), 331–439. [MR](#) [Zbl](#)
- [Colmez 2003] P. Colmez, “Les conjectures de monodromie p -adiques”, exposé 897, pp. 53–101 dans *Séminaire Bourbaki* 2001/2002, Astérisque **290**, Soc. Math. de France, Paris, 2003. [MR](#) [Zbl](#)
- [Colmez et Nizioł 2017] P. Colmez et W. Nizioł, “Syntomic complexes and p -adic nearby cycles”, *Invent. Math.* **208**:1 (2017), 1–108. [MR](#) [Zbl](#)
- [Colmez et Nizioł 2021a] P. Colmez et W. Nizioł, “On the cohomology of p -adic analytic spaces, I: The basic comparison theorem”, prépublication, 2021. [arXiv 2104.13448](#)
- [Colmez et Nizioł 2021b] P. Colmez et W. Nizioł, “On the cohomology of p -adic analytic spaces, II: The C_{st} -conjecture”, prépublication, 2021. [arXiv 2108.12785](#)
- [Conrad 2003] B. Conrad, “Cohomological descent”, prépublication, 2003, voir <https://math.stanford.edu/~conrad/papers/hypercover.pdf>.
- [Diao et al. 2019] H. Diao, K.-W. Lan, R. Liu et X. Zhu, “Logarithmic adic spaces: some foundational results”, prépublication, 2019. [arXiv 1912.09836](#)
- [Faltings 2002] G. Faltings, “Almost étale extensions”, pp. 185–270 dans *Cohomologies p -adiques et applications arithmétiques, II*, Astérisque **279**, Soc. Math. de France, Paris, 2002. [MR](#) [Zbl](#)
- [Fontaine 1994] J.-M. Fontaine, “Le corps des périodes p -adiques”, pp. 59–111 dans *Périodes p -adiques* (Bures-sur-Yvette, France, 1988), Astérisque **223**, Soc. Math. de France, Paris, 1994. [MR](#) [Zbl](#)
- [Fontaine et Messing 1987] J.-M. Fontaine et W. Messing, “ p -adic periods and p -adic étale cohomology”, pp. 179–207 dans *Current trends in arithmetical algebraic geometry* (Arcata, CA, 1985), édité par K. A. Ribet, *Contemp. Math.* **67**, Amer. Math. Soc., Providence, RI, 1987. [MR](#) [Zbl](#)
- [Hyodo 1988] O. Hyodo, “A note on p -adic étale cohomology in the semistable reduction case”, *Invent. Math.* **91**:3 (1988), 543–557. [MR](#) [Zbl](#)
- [Kato 1994] K. Kato, “Semi-stable reduction and p -adic étale cohomology”, pp. 269–293 dans *Périodes p -adiques* (Bures-sur-Yvette, France, 1988), Astérisque **223**, Soc. Math. de France, Paris, 1994. [MR](#) [Zbl](#)
- [Kedlaya et Liu 2016] K. S. Kedlaya et R. Liu, “Relative p -adic Hodge theory, II: Imperfect period rings”, prépublication, 2016. [arXiv 1602.06899](#)
- [Nekovář et Nizioł 2016] J. Nekovář et W. Nizioł, “Syntomic cohomology and p -adic regulators for varieties over p -adic fields”, *Algebra Number Theory* **10**:8 (2016), 1695–1790. [MR](#) [Zbl](#)
- [Nizioł 2008] W. Nizioł, “Semistable conjecture via K -theory”, *Duke Math. J.* **141**:1 (2008), 151–178. [MR](#) [Zbl](#)
- [Nizioł 2009] W. Nizioł, “On uniqueness of p -adic period morphisms”, *Pure Appl. Math. Q.* **5**:1 (2009), 163–212. [MR](#) [Zbl](#)
- [Nizioł 2020] W. Nizioł, “On uniqueness of p -adic period morphisms, II”, *Compos. Math.* **156**:9 (2020), 1915–1964. [MR](#) [Zbl](#)
- [Scholze 2013] P. Scholze, “ p -adic Hodge theory for rigid-analytic varieties”, *Forum Math. Pi* **1** (2013), art. id. e1. [MR](#) [Zbl](#)
- [Stacks 2005–] “The Stacks project”, référence web, 2005–, voir <http://stacks.math.columbia.edu>.

[Tsuji 1999] T. Tsuji, “ p -adic étale cohomology and crystalline cohomology in the semi-stable reduction case”, *Invent. Math.* **137**:2 (1999), 233–411. [MR](#) [Zbl](#)

Communicated by Bhargav Bhatt

Received 2021-01-26 Revised 2022-03-22 Accepted 2022-05-10

s.gilles@imperial.ac.uk

*Huxley Building, South Kensington Campus, Imperial College London,
London, United Kingdom*

Maximizing Sudler products via Ostrowski expansions and cotangent sums

Christoph Aistleitner and Bence Borda

There is an extensive literature on the asymptotic order of Sudler's trigonometric product $P_N(\alpha) = \prod_{n=1}^N |2 \sin(\pi n\alpha)|$ for fixed or for "typical" values of α . We establish a structural result which for a given α characterizes those N for which $P_N(\alpha)$ attains particularly large values. This characterization relies on the coefficients of N in its Ostrowski expansion with respect to α , and allows us to obtain very precise estimates for $\max_{1 \leq N \leq M} P_N(\alpha)$ and for $\sum_{N=1}^M P_N(\alpha)^c$ in terms of M , for any $c > 0$. Furthermore, our arguments give a natural explanation of the fact that the value of the hyperbolic volume of the complement of the figure-eight knot appears generically in results on the asymptotic order of the Sudler product and of the Kashaev invariant.

1. Introduction and statement of results

During the last decades many authors have studied the asymptotic order of the so-called Sudler product

$$P_N(\alpha) = \prod_{n=1}^N |2 \sin(\pi n\alpha)|, \quad (1)$$

either on average (with respect to α) or for particular values of α . It is known that the order of (1) for a fixed value of α depends sensitively on the Diophantine approximation properties of α , and in particular on the continued fraction expansion of α . If $\alpha \in \mathbb{Q}$, then clearly the product (1) vanishes for all sufficiently large N , so for the asymptotic analysis we can restrict ourselves to the case when α is irrational.

Of particular interest is the case when α is a quadratic irrational, which means that the continued fraction expansion of α is eventually periodic. A remarkable result was recently obtained by Grepstad, Kaltenböck and Neumüller [Grepstad et al. 2019], who proved that for the golden mean $\phi = \frac{1}{2}(1 + \sqrt{5})$,

$$0 < \liminf_{N \rightarrow \infty} P_N(\phi) < \infty,$$

thereby solving a long-standing problem of Erdős and Szekeres [1959]. In [Aistleitner et al. 2020] this result was complemented by

$$0 < \limsup_{N \rightarrow \infty} \frac{P_N(\phi)}{N} < \infty,$$

MSC2020: 11A63, 11J70, 11L03, 26D05.

Keywords: continued fractions, Ostrowski expansion, cotangent sum, quadratic irrationals, Sudler product, Kashaev invariant.

so the asymptotic order of $P_N(\phi)$ is completely understood. Interestingly, there is a transition in the behavior of quadratic irrationals whose continued fraction expansion is of the particularly simple form $\alpha = [0; \bar{a}]$ as the value of a increases (here and in the sequel, the overline denotes period): it turns out that $\liminf_{N \rightarrow \infty} P_N(\alpha) > 0$ as long as $a \leq 5$, while $\liminf_{N \rightarrow \infty} P_N(\alpha) = 0$ when $a \geq 6$. A similar characterization applies to $\limsup_{N \rightarrow \infty} P_N(\alpha)/N < \infty$. A generalization of such a criterion to more general quadratic irrationals can be found in [Grepstad et al. 2022].

Lubinsky [1999] proved that for any badly approximable α ,

$$N^{-c_1} \ll_{\alpha} P_N(\alpha) \ll_{\alpha} N^{c_2}$$

with some $c_1, c_2 \geq 0$, and asked for the smallest possible constants $c_1 = c_1(\alpha)$ and $c_2 = c_2(\alpha)$ for which this holds.¹ As noted in [Aistleitner and Borda 2022], for any badly approximable α , we have that $c_2(\alpha) = c_1(\alpha) + 1$. From what was said above for $\alpha = [0; \bar{a}]$, we have $c_1(\alpha) = 0$ and $c_2(\alpha) = 1$ for $a \in \{1, 2, 3, 4, 5\}$, but in general it seems to be very difficult to calculate the values of these two constants. In [Aistleitner and Borda 2022] it was shown that for any quadratic irrational α ,

$$c_2(\alpha) = c_1(\alpha) + 1 = \frac{1}{4\pi} \text{Vol}(4_1) \cdot \frac{a_{\text{avg}}(\alpha)}{\log \lambda(\alpha)} + O\left(\frac{1 + \log A(\alpha)}{\log \lambda(\alpha)}\right). \quad (2)$$

Here

$$\text{Vol}(4_1) = 4\pi \int_0^{\frac{5}{6}} \log(2 \sin(\pi x)) \, dx \approx 2.02988 \quad (3)$$

is the hyperbolic volume of the complement of the figure-eight knot (more on this below; here and in the sequel, “ 4_1 ” is the Alexander–Briggs notation for the figure-eight knot), $a_{\text{avg}}(\alpha) = \lim_{k \rightarrow \infty} (a_1 + \dots + a_k)/k$ denotes the average of the partial quotients within a period, $\lambda(\alpha)$ is the (easily computable) number for which the convergents $p_k/q_k = [a_0; a_1, a_2, \dots, a_k]$ satisfy $\log q_k \sim (\log \lambda(\alpha))k$ as $k \rightarrow \infty$, and $A(\alpha) = \max_{k \geq 1} a_k$ is the maximum of the partial quotients. The key purpose of the present paper is to obtain a significantly improved version of (2), and to give a structural description of those values of N for which $P_N(\alpha)$ attains particularly large resp. small values. These two aims are very closely related; roughly speaking, knowing the particular structure of those N which lead to extreme values of $P_N(\alpha)$ allows us to obtain improved estimates on $c_1(\alpha)$ and $c_2(\alpha)$, since the structural information allows a refined analysis of the terms that control $c_1(\alpha)$ and $c_2(\alpha)$. The “structure” of N which is alluded to here is a particular structure of the coefficients in its Ostrowski representation, which is a numeration system for integers based on the continued fraction denominators of α . Very roughly speaking, it turns out that $P_N(\alpha)$ is particularly large resp. small if the Ostrowski coefficients of N are all $\frac{5}{6}$ resp. $\frac{1}{6}$ of their maximal possible size; this fact will also give a natural explanation for the appearance of the constant $\text{Vol}(4_1)$ in formula (2) above, as well as in many other related formulas, such as those in [Bettin and Drappeau 2022b].

¹Throughout the paper we write $x_N \ll y_N$ or $x_N = O(y_N)$ when $|x_N| \leq C y_N$ with some appropriate constant $C > 0$. All implied constants are universal unless the opposite is explicitly indicated by a subscript; e.g., $x_N \ll_{\alpha} y_N$ and $x_N = O_{\alpha}(y_N)$ mean that the implied constant may depend on α .

Before presenting our results, we note some connections to other areas of mathematics. Early investigations of the Sudler product were carried out by Erdős and Szekeres [1959] and Sudler [1964]. Since then such products have appeared in various contexts, including partition functions, KAM theory, q -series, Padé approximations, and the analytic continuation of Dirichlet series. In particular, pointwise upper bounds for Sudler products at quadratic irrationals played a crucial role in the counterexample of Lubinsky [2003] to the Baker–Gammel–Wills conjecture, where they were used to bound the Taylor series coefficients of the Rogers–Ramanujan function. Pointwise upper bounds for Sudler products also played a key role in the solution of the “ten martini problem” by Avila and Jitomirskaya [2009]. For a more detailed exposition of the connection between the Sudler product and other mathematical subjects we refer the reader to [Aistleitner et al. 2018; Knill and Tangerman 2011; Verschueren and Mestel 2016]. Note that the Sudler product can be written using the q -Pochhammer symbol as

$$P_N(\alpha) = |(q; q)_N| = |(1 - q)(1 - q^2) \cdots (1 - q^N)| \quad \text{with } q = e^{2\pi i \alpha}.$$

Compare this with the definition of the so-called Kashaev invariant of the figure-eight knot, given by

$$\mathcal{J}_{4_1,0}(q) = \sum_{N=0}^{\infty} |(q; q)_N|^2. \tag{4}$$

This series is convergent if and only if α is rational (i.e., q is a root of unity). The Kashaev invariant is a quantum knot invariant arising from the colored Jones polynomial, and the figure-eight knot is the simplest hyperbolic knot. For more background, we refer the reader to [Bettin and Drappeau 2022b; Murakami and Murakami 2001; Murakami 2011]. Here we only note that the Kashaev invariant can be written as a sum of squares of Sudler products; however, by its very nature the Kashaev invariant is only interesting when α is rational (since otherwise the series diverges), while the asymptotic order of the Sudler product is only interesting when α is irrational (since otherwise the product vanishes for all sufficiently large indices). However, it is possible to approximate the value of the Sudler product at an irrational α by the value at a rational number close to α (such as a continued fraction approximation to α), thereby switching from Kashaev invariants to Sudler products and vice versa; see [Aistleitner and Borda 2022] for a precise statement. Generally, this connection suggests studying the asymptotic order of expressions of the form

$$\left(\sum_{N=1}^M P_N(\alpha)^2 \right)^{\frac{1}{2}}$$

or, more generally,

$$\left(\sum_{N=1}^M P_N(\alpha)^c \right)^{1/c} \quad \text{for some } c > 0,$$

which can be seen as describing the average order of $P_N(\alpha)$ with respect to N . With this notation the problem concerning the upper asymptotic order of $P_N(\alpha)$ corresponds to the maximum norm, that is, to the case $c = \infty$. In connection with a problem posed by Bettin and Drappeau [2022b], we [Aistleitner and Borda 2022] settled the case when α is a quadratic irrational, showing that in this case for any real $c > 0$

and any $k \geq 1$,

$$\log \left(\sum_{N=0}^{q_k-1} P_N(\alpha)^c \right)^{1/c} = K_c(\alpha)k + O_\alpha \left(\max \left\{ 1, \frac{1}{c} \right\} \right), \tag{5}$$

and

$$\log \max_{0 \leq N < q_k} P_N(\alpha) = K_\infty(\alpha)k + O_\alpha(1)$$

with some constants $K_c(\alpha), K_\infty(\alpha) > 0$. We repeat that $K_2(\alpha)$ in (5) is closely related to the Kashaev invariant as defined in (4). Note also that the constants in the question of Lubinsky can be expressed as $c_2(\alpha) = c_1(\alpha) + 1 = K_\infty(\alpha) / \log \lambda(\alpha)$, where $\lambda(\alpha) > 1$ is the same easily computable constant as in (2). However, in [Aistleitner and Borda 2022] it remained open whether $K_c(\alpha)$ actually depends on c or not. This is related to the question whether $P_N(\alpha)$ is exceptionally large only for a very small number of indices N causing the sum in (5) to be essentially dominated by a small number of summands which are of extremal size. In this paper we prove that this is not the case, and that (under certain technical assumptions) the overall order of the sum $\sum_{N=0}^{q_k-1} P_N(\alpha)^c$ is not caused by a small number of exceptionally large summands. In particular, $K_c(\alpha)$ does indeed depend on c .

We close this discussion by noting that the Kashaev invariant features prominently in the seminal paper of Zagier [2010] on quantum modular forms, where it is introduced as being “the most mysterious and in many ways the most interesting” example. Zagier records certain modularity properties of the function $\mathcal{J}_{4,0}$, and suggests that the function $h(\alpha) = \log(\mathcal{J}_{4,0}(e^{2\pi i \alpha}) / \mathcal{J}_{4,0}(e^{2\pi i / \alpha}))$, relating the value of the Kashaev invariant at α to its value at $1/\alpha$, appears to be continuous at irrationals. This continuity hypothesis has been driving much of the recent research in this area, but as a whole it is still wide open. See [Aistleitner and Borda 2022; Bettin and Drappeau 2022a; 2022b].

We now state our main results. For the rest of the paper, we fix an irrational $\alpha = [a_0; a_1, a_2, \dots]$ with convergents $p_k/q_k = [a_0; a_1, \dots, a_k]$.

Theorem 1. *Assume that*

$$\frac{\log a_k}{a_{k+1}} \leq T \quad \text{for all } k \geq k_0 \tag{6}$$

with some constants $k_0, T \geq 1$. Let $N = \sum_{k=0}^{K-1} b_k q_k$ be the Ostrowski expansion of a nonnegative integer, and set

$$N^* = \sum_{k=0}^{K-1} b_k^* q_k, \quad \text{with } b_k^* = \left\lfloor \frac{5}{6} a_{k+1} \right\rfloor. \tag{7}$$

Then

$$\log P_N(\alpha) = \log P_{N^*}(\alpha) - \sum_{k=0}^{K-1} d_k(N) + O_T \left(\sum_{k=1}^K \frac{1}{a_k} \right) + O_\alpha(1)$$

with some $d_k(N)$ satisfying the following for all $0 \leq k \leq K - 1$:

- (i) $d_k(N) \geq 0.2326(b_k - b_k^*)^2 / a_{k+1}$, with equality if $b_k = b_k^*$.

(ii) If $b_k \leq 0.99a_{k+1}$, then

$$d_k(N) = a_{k+1} \int_{b_k/a_{k+1}}^{b_k^*/a_{k+1}} \log|2 \sin(\pi x)| dx + O_T \left(\frac{|b_k - b_k^*|}{a_{k+1}} + I_{\{b_k \leq 0.01a_{k+1}\}} \log a_{k+1} \right). \tag{8}$$

Remark. In the formula above $I_{\{b_k \leq 0.01a_{k+1}\}}$ denotes the indicator of $b_k \leq 0.01a_{k+1}$. Formula (8) gives the precise asymptotics of $d_k(N)$ in the regime $b_k - b_k^* \approx a_{k+1}$. Using a first-order Taylor approximation of $\log|2 \sin(\pi x)|$ around $x = \frac{5}{6}$, we immediately deduce from (8) that

$$d_k(N) = \frac{\pi\sqrt{3}}{2} \cdot \frac{(b_k - b_k^*)^2}{a_{k+1}} + O_T \left(\frac{|b_k - b_k^*|}{a_{k+1}} + \frac{|b_k - b_k^*|^3}{a_{k+1}^2} \right), \tag{9}$$

yielding the precise asymptotics in the regime $b_k - b_k^* = o(a_{k+1})$.

Theorem 1 asserts that $P_N(\alpha)$ is particularly large when $N = N^*$, and that an integer N whose Ostrowski expansion deviates significantly from that of N^* will lead to much smaller values of $P_N(\alpha)$. The magnitude of $P_N(\alpha)/P_{N^*}(\alpha)$ is quantified in terms of the “distance” between the Ostrowski expansions of N and N^* . As simple illustrative examples we mention that Theorem 1 with $T = 1$ applies to $\alpha = [0; \bar{a}]$, and also to well-approximable irrationals with $a_1 \leq a_2 \leq \dots \leq a_k \rightarrow \infty$. Note that we do not claim that the maximum is attained at precisely N^* ; however, for example, for $\alpha = [0; \bar{a}]$ it follows that the Ostrowski coefficients of the integer at which the maximum $\max_{0 \leq N < q_K} P_N(\alpha)$ is attained satisfy $b_k = \frac{5}{6}a + O(1/\varepsilon)$ for all but $\leq \varepsilon K$ indices $0 \leq k \leq K - 1$.

The significance of the value $\frac{5}{6}$ in our definition of N^* in (7) is that it is a solution of the equation $|2 \sin(\pi x)| = 1$. From the proofs it will become visible that choosing a value of b_k smaller than $\frac{5}{6}a_{k+1}$ essentially means missing out on potential factors which exceed 1, while choosing b_k larger than $\frac{5}{6}a_{k+1}$ essentially leads to extra factors which are smaller than 1; clearly both effects are counterproductive if our aim is to maximize $P_N(\alpha)$. The heuristic reasoning underpinning all the constructions and results in the present paper will be described in some detail in Section 2.1 below. The value 0.2326 in property (i) is explained by

$$\frac{1}{(5/6)^2} \int_0^{\frac{5}{6}} \log|2 \sin(\pi x)| dx = \frac{9 \text{Vol}(4_1)}{25\pi} = 0.23260748 \dots$$

Any constant less than $9 \text{Vol}(4_1)/(25\pi)$ would work; the sharpness of this value is easily seen by letting $b_k/a_{k+1} \rightarrow 0$ in (8). The values 0.99 resp. 0.01 in property (ii), on the other hand, are basically accidental; any constants $C < 1$ resp. $C > 0$ would work, with the implied constants depending also on the choice of C . The reason why we have to stay away from $x = 0$ and $x = 1$ is that the function $\log|2 \sin(\pi x)|$ has singularities there.

Condition (6) is related to the behavior of a cotangent sum; see Section 3.2. Probably this condition could be relaxed in some way, but it seems very difficult to obtain a version of Theorem 1 without any regularity assumption on the relative size of the partial quotients, since for a number α whose partial quotients are of very different orders of magnitude the “optimal” Ostrowski coefficients b_k^* should depend on a_1, a_2, \dots, a_{k+1} in a more complicated way than the one suggested by (7); see also Figure 2 below.

Formulas (8) and (9) allow us to give precise estimates for the number of integers $0 \leq N < q_K$ for which $P_N(\alpha)$ is particularly large. This is stated in Theorem 2 below. The value 0.01 in the statement of the theorem could of course again be replaced by any $C > 0$, with the implied constants depending also on $C > 0$.

Theorem 2. *Assume that (6) holds and let N^* be defined as in (7). Then for any real $c \geq 0.01$,*

$$\begin{aligned} & \log \left(\sum_{N=0}^{q_K-1} P_N(\alpha)^c \right)^{1/c} \\ &= \log P_{N^*}(\alpha) + \frac{1}{2c} \sum_{k=1}^K \log \frac{2a_k}{\sqrt{3c}} + O_T \left(\sum_{k=1}^K \left(\frac{\log^{1/2}(a_k/c+2)}{c^{1/2}a_k^{1/2}} + \frac{\log^{3/2}(a_k/c+2)}{c^{3/2}a_k^{1/2}} + \frac{1}{a_k} \right) \right) + O_\alpha(1), \end{aligned} \tag{10}$$

and

$$\log \max_{0 \leq N < q_K} P_N(\alpha) = \log P_{N^*}(\alpha) + O_T \left(\sum_{k=1}^K \frac{1}{a_k} \right) + O_\alpha(1). \tag{11}$$

Our third result shows that because of the particular structure of N^* , we can calculate the value of $P_{N^*}(\alpha)$ up to a very high precision.

Theorem 3. *Assume that (6) holds, and let N^* be defined as in (7). Then*

$$\log P_{N^*}(\alpha) = \frac{1}{4\pi} \text{Vol}(4_1) \sum_{k=1}^K a_k + \frac{1}{2} \sum_{k=1}^K \log a_k + O_T \left(\sum_{k=1}^K \frac{1 + \log(a_k a_{k+1})}{a_{k+1}} \right) + O_\alpha(1).$$

Let us now compare the results obtained here with the previously known best results. Consider first $\alpha = [0; \bar{a}]$. In [Aistleitner and Borda 2022] we proved that for any $0 < c \leq \infty$, the constant $K_c(\alpha)$ defined in (5) satisfies

$$K_c(\alpha) = \frac{1}{4\pi} \text{Vol}(4_1)a + O \left(\max \left\{ 1, \frac{1}{c} \right\} (1 + \log a) \right),$$

with the dependence on c hidden in the error term. Taking the asymptotics as $K \rightarrow \infty$ in Theorems 2 and 3, we immediately obtain the improvement

$$\begin{aligned} K_c(\alpha) &= \frac{1}{4\pi} \text{Vol}(4_1)a + \frac{1}{2} \log a + \frac{1}{2c} \log \frac{2a}{\sqrt{3c}} \\ &+ O \left(\frac{\log^{1/2}(a/c+2)}{c^{1/2}a^{1/2}} + \frac{\log^{3/2}(a/c+2)}{c^{3/2}a^{1/2}} + \frac{1 + \log a}{a} \right), \quad 0.01 \leq c \leq \infty. \end{aligned}$$

Note that the dependence on c is visible in the regime $c \ll (a \log \log(a+2))/\log(a+2)$; above this threshold, the term $(1/(2c)) \log(2a/\sqrt{3c})$ is negligible compared to the error term $(1 + \log a)/a$, and $K_c(\alpha)$ becomes indistinguishable from

$$K_\infty(\alpha) = \frac{1}{4\pi} \text{Vol}(4_1)a + \frac{1}{2} \log a + O \left(\frac{1 + \log a}{a} \right).$$

As for the question of Lubinsky, the previously known best result (from [Aistleitner and Borda 2022]), $c_2(\alpha) = c_1(\alpha) + 1 = \frac{1}{4\pi} \text{Vol}(4_1) \cdot (a/\log a) + O(1)$, is improved to

$$c_2(\alpha) = c_1(\alpha) + 1 = \frac{1}{4\pi} \text{Vol}(4_1) \cdot \frac{a}{\log a} + \frac{1}{2} + O\left(\frac{1}{a}\right), \quad a \geq 2.$$

Theorems 2 and 3 give similar improvements for more general badly approximable irrationals whose partial quotients are roughly of the same order of magnitude; this is measured by the parameter $T \geq 1$ in (6).

We also obtain improvements for certain well-approximable irrationals. It is known [Aistleitner and Borda 2022; Bettin and Drappeau 2022b] that if the average partial quotient $(a_1 + \dots + a_k)/k$ diverges to infinity, then under some mild additional assumptions on α for any real $c > 0$ we have

$$\log\left(\sum_{N=0}^{q_k-1} P_N(\alpha)^c\right)^{1/c} \sim \frac{1}{4\pi} \text{Vol}(4_1)(a_1 + \dots + a_k) \quad \text{as } k \rightarrow \infty,$$

and

$$\log \max_{0 \leq N < q_k} P_N(\alpha) \sim \frac{1}{4\pi} \text{Vol}(4_1)(a_1 + \dots + a_k) \quad \text{as } k \rightarrow \infty.$$

Theorems 2 and 3 improve these under condition (6) by identifying logarithmic correction terms.

While the main focus of this paper is maximizing the value of Sudler products, we mention that our results also shed light on minimal values. These two problems are closely related: we observed in [Aistleitner and Borda 2022] that for an arbitrary irrational α and any $0 \leq N < q_K$ we have

$$\log P_N(\alpha) + \log P_{q_K-N-1}(\alpha) = \log q_K + O\left(\frac{1 + \log \max_{1 \leq k \leq K} a_k}{a_{K+1}}\right),$$

and, in particular,

$$\log \max_{0 \leq N < q_K} P_N(\alpha) + \log \min_{0 \leq N < q_K} P_N(\alpha) = \log q_K + O\left(\frac{1 + \log \max_{1 \leq k \leq K} a_k}{a_{K+1}}\right).$$

Therefore $P_N(\alpha)$ is particularly small when $P_{q_K-N-1}(\alpha)$ is particularly large, and vice versa. More precisely, by following the steps in the proof of Theorem 3 we deduce that under assumption (6), $N_* := \sum_{k=0}^{K-1} \lfloor \frac{1}{6} a_{k+1} \rfloor q_k$ satisfies

$$\log P_{N_*}(\alpha) = -\frac{1}{4\pi} \text{Vol}(4_1) \sum_{k=1}^K a_k + \frac{1}{2} \sum_{k=1}^K \log a_k + O_T\left(\sum_{k=1}^K \frac{1 + \log(a_k a_{k+1})}{a_{k+1}}\right) + O_\alpha(1).$$

The negative coefficient is explained by $\int_0^{\frac{1}{6}} \log(2 \sin(\pi x)) dx = -\text{Vol}(4_1)/(4\pi)$; see (3). The previous two formulas, Theorem 2 and the fact $\log q_K = \sum_{k=1}^K \log a_k + O(\sum_{k=1}^K 1/a_k)$ yield

$$\log \min_{0 \leq N < q_K} P_N(\alpha) = \log P_{N_*}(\alpha) + O\left(\frac{1 + \log \max_{1 \leq k \leq K} a_k}{a_{K+1}}\right) + O_T\left(\sum_{k=1}^K \frac{1 + \log(a_k a_{k+1})}{a_{k+1}}\right) + O_\alpha(1),$$

a perfect analogue of (11).

Before coming to the more technical parts, we briefly lay out the further content of this paper. In [Section 2](#) we introduce a perturbed version of the Sudler product, which allows a decomposition of a full product $P_N(\alpha)$ into subproducts whose number of factors is always a continued fraction denominator of α , thereby naturally bringing into play the Ostrowski expansion of N . In [Section 2.1](#) we give a detailed heuristic sketch of how this decomposition leads to [Theorems 1, 2 and 3](#). In particular it will become clear how the constant $\frac{5}{6}$ in the definition of N^* and how the constant $\text{Vol}(4_1)$ in the conclusion of the theorems arise. A key ingredient (in the heuristic as well as in the actual proofs) is the fact that the shifted products P_{q_k} have a limiting behavior, in an appropriate sense. This has been experimentally observed in [\[Aistleitner et al. 2020\]](#), and in the present paper we give proofs for this fact, which is stated as [Theorems 4 and 5](#) in [Section 2.2](#). [Section 3](#) contains approximation formulas for shifted Sudler products and in particular [Proposition 12](#), which plays a central role in the proofs of the theorems. To obtain our approximation formula we introduce a certain cotangent sum which controls an important part of the behavior of the shifted Sudler product. Such cotangent sums have a rich arithmetic structure, and we make crucial use of a reciprocity formula of Bettin and Conrey [\[2013\]](#). [Sections 4–6](#) contain the proofs of [Theorems 1–3](#), respectively, and finally [Section 7](#) contains the proofs of [Theorems 4 and 5](#).

2. Shifted Sudler products

Let

$$P_N(\alpha, x) := \prod_{n=1}^N |2 \sin(\pi(n\alpha + x))|, \quad \alpha, x \in \mathbb{R}$$

denote a shifted form of the Sudler product. Given a nonnegative integer with Ostrowski expansion $N = \sum_{k=0}^{K-1} b_k q_k$, let us also introduce the notation

$$\varepsilon_k(N) := q_k \sum_{\ell=k+1}^{K-1} (-1)^{k+\ell} b_\ell \|q_\ell \alpha\|. \tag{12}$$

It is then easy to see that

$$P_N(\alpha) = \prod_{k=0}^{K-1} \prod_{b=0}^{b_k-1} P_{q_k}(\alpha, (-1)^k (b q_k \|q_k \alpha\| + \varepsilon_k(N)) / q_k), \tag{13}$$

which will serve as a fundamental tool in the proof of our results. This product form of $P_N(\alpha)$ was first used by Grepstad, Kaltenböck and Neumüller [\[Grepstad et al. 2019\]](#), and later also in [\[Aistleitner et al. 2020; Grepstad et al. 2020; 2022\]](#); for a detailed proof of [\(13\)](#) see [\[Aistleitner and Borda 2022, Lemma 2\]](#). As we will see, here $-1 < b q_k \|q_k \alpha\| + \varepsilon_k(N) < 1$, and therefore understanding the behavior of the function $P_{q_k}(\alpha, (-1)^k x / q_k)$ on the interval $(-1, 1)$ will play a crucial role.

2.1. The heuristic picture. Before we give the details of how to estimate the components of the product in [\(13\)](#), we present a heuristic picture of how the factors in this product formula behave, what the

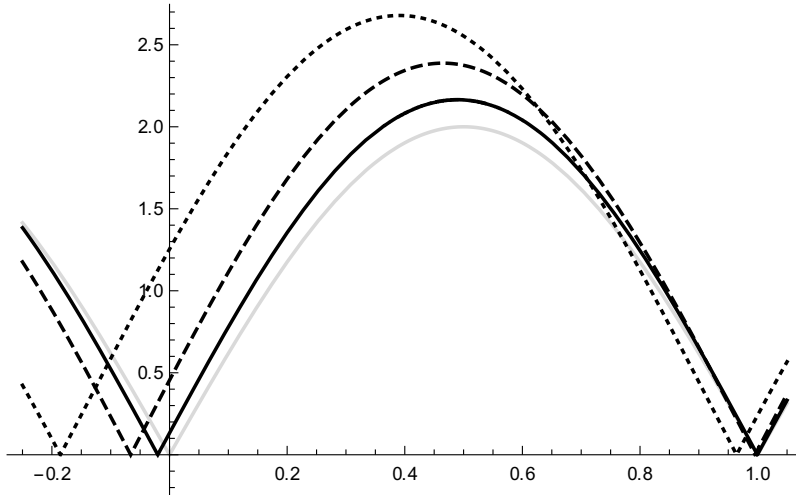

Figure 1. The function $P_{q_k}(\alpha, (-1)^k x/q_k)$ for $k = 4$ and $\alpha = [0; \bar{a}]$, with $a = 5$ (dotted), $a = 15$ (dashed) and $a = 50$ (solid line). The picture remains virtually identical for a larger choice of k . Note how the functions in the plot approach $|2 \sin(\pi x)|$ (light gray) as the value of a increases. Details are given in Section 2.2 below.

significance of the Ostrowski coefficients of N is, why the Sudler product is essentially maximized at numbers N having all the Ostrowski coefficients at $\frac{5}{6}$ of their maximal possible size, and how the hyperbolic volume of the complement of the figure-eight knot as defined in (3) appears. Assume that $0 \leq N < q_K$, so that N has Ostrowski expansion $N = \sum_{k=0}^{K-1} b_k q_k$. Recall that $0 \leq b_k \leq a_{k+1}$. Very roughly, we have $q_k \|q_k \alpha\| \approx 1/a_{k+1}$. It turns out that $P_{q_k}(\alpha, (-1)^k x/q_k) \approx |2 \sin(\pi x)|$. This observation is formalized in a precise form in Proposition 12 below; see also Figure 1 and Theorems 4 and 5. Thus, ignoring the numbers $\varepsilon_k(N)$ in (13) for the moment, we have

$$P_{q_k}(\alpha, (-1)^k (b_k q_k \|q_k \alpha\| + \varepsilon_k(N))/q_k) \approx |2 \sin(\pi b/a_{k+1})|,$$

and so, offhandedly discarding the factor corresponding to $b = 0$, we have

$$\prod_{b=0}^{b_k-1} P_{q_k}(\alpha, (-1)^k (b q_k \|q_k \alpha\| + \varepsilon_k(N))/q_k) \approx \prod_{b=1}^{b_k-1} |2 \sin(\pi b/a_{k+1})|. \tag{14}$$

Note that $b/a_{k+1} \in [0, 1]$. We have $2 \sin(\pi x) \geq 1$ for $x \in [\frac{1}{6}, \frac{5}{6}]$, and $2 \sin(\pi x) \leq 1$ for $x \in [0, \frac{1}{6}] \cup [\frac{5}{6}, 1]$. This suggests that in order to maximize the product in (14), we should choose $b_k \approx \frac{5}{6} a_{k+1}$, since by doing so we catch as many factors exceeding 1 while avoiding unnecessary factors smaller than 1; in other words, $P_N(\alpha)$ is essentially maximized when $N = N^*$. This heuristic also gives us a rough general approximation for the value of $P_N(\alpha)$. Using (13) and assuming that all a_k 's are “large”, we roughly have

$$P_N(\alpha) \approx \prod_{k=0}^{K-1} \exp\left(\sum_{b=1}^{b_k-1} \log(2 \sin(\pi b/a_{k+1}))\right) \approx \exp\left(\sum_{k=0}^{K-1} a_{k+1} \int_0^{b_k/a_{k+1}} \log(2 \sin(\pi x)) dx\right).$$

In particular, for $N = N^*$ when $b_k/a_{k+1} \approx \frac{5}{6}$, the hyperbolic volume of the complement of the figure-eight knot naturally appears, and we have

$$P_{N^*}(\alpha) \approx \exp\left(\sum_{k=0}^{K-1} a_{k+1} \int_0^{\frac{5}{6}} \log(2 \sin(\pi x)) \, dx\right) = \exp\left(\frac{1}{4\pi} \text{Vol}(4_1) \sum_{k=1}^K a_k\right);$$

recall the definition of $\text{Vol}(4_1)$ in (3). If we want to minimize $P_N(\alpha)$ instead, the same reasoning suggests that we should choose $b_k \approx \frac{1}{6}a_{k+1}$ to catch as many factors smaller than 1 as possible. While this heuristic serves as a good basic illustration of the behavior of the Sudler product, the actual situation clearly is much more delicate; in particular, the function $\log(2 \sin(\pi x))$ has singularities at $x = 0$ and $x = 1$, which carefully have to be taken care of.

Now let us come back to the influence of the numbers $\varepsilon_k(N)$. As sketched above, the term $bq_k \|q_k \alpha\|$ in (14) is of order roughly b/a_{k+1} . By (12) we roughly have $|\varepsilon_k(N)| \leq 1/a_{k+1}$, so typically the $\varepsilon_k(N)$'s are small in comparison with $bq_k \|q_k \alpha\|$. We also see in the definition given in (12) that the number $\varepsilon_k(N)$ depends on the Ostrowski coefficients b_{k+1}, b_{k+2}, \dots . It turns out that we cannot simply ignore the influence of the $\varepsilon_k(N)$'s; quite on the contrary, controlling the influence of these numbers has been a key ingredient in recent work such as [Aistleitner et al. 2020; Grepstad et al. 2019], and they also play a crucial role in the present paper. In particular, the influence of the $\varepsilon_k(N)$'s is crucial for all those factors in $P_{q_k}(\alpha, (-1)^k (bq_k \|q_k \alpha\| + \varepsilon_k(N))/q_k)$ for which b is such that b/a_{k+1} is either very close to 0 or very close to 1. The punchline is the following. If a number N has an Ostrowski representation which is very different from the one of N^* , then by the coarse argument sketched above we know that $P_N(\alpha)$ is much smaller than $P_{N^*}(\alpha)$. On the other hand, if N has an Ostrowski representation which is very similar to that of N^* (or in particular if $N = N^*$), then we know what the values of the $\varepsilon_k(N)$'s are, since they depend on the Ostrowski coefficients of N . In other words, once we have established a structural result which controls the Ostrowski expansion of those N for which $P_N(\alpha)$ is large (Theorem 1), we can obtain a very precise result on the maximal asymptotic order of $P_N(\alpha)$ (combining (11) of Theorem 2 and Theorem 3), since control of the Ostrowski coefficients of N allows us to control the numbers $\varepsilon_k(N)$, which in turn gives us exact control of the order of $P_N(\alpha)$.

There is a further important effect, which is particularly strong when α has some partial quotients which are very much larger than others. As Lemma 8 and Proposition 12 below will show, a more precise approximation for P_{q_k} is

$$P_{q_k}(\alpha, (-1)^k x/q_k) \approx |2 \sin(\pi x)| e^{(\log a_k)/a_{k+1}},$$

where the exponential factor comes from a cotangent sum; see also Figure 2 and Sections 2.2 and 3.2. If a_k and a_{k+1} are of similar size, then the factor $e^{(\log a_k)/a_{k+1}}$ is negligible. However, if a_k is much larger than a_{k+1} , then this factor plays a significant role.

The heuristic sketched above suggests that in such a case the corresponding Ostrowski coefficients should be chosen significantly larger than $\frac{5}{6}a_{k+1}$, since there is a wider range of values of x for which $P_{q_k}(\alpha, (-1)^k x/q_k)$ exceeds 1. However, very remarkably, this line of reasoning turns out to be wrong,

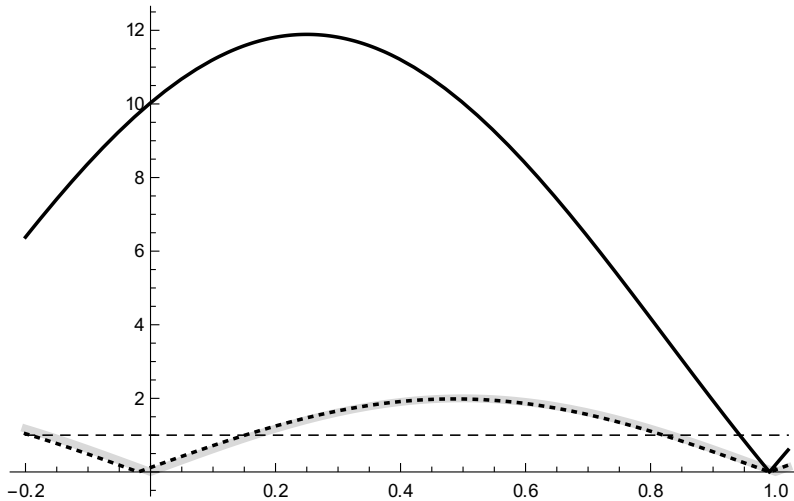

Figure 2. The function $P_{q_4}(\alpha, x/q_4)$ for $\alpha = [0; \overline{2, 50}]$ (solid line). Note that this function is much larger than $|2 \sin(\pi x)|$ (light gray), which reflects the fact that $a_4 = 50$ is much larger than $a_3 = 2$. In contrast, $P_{q_5}(\alpha, -x/q_5)$ (dotted line) is virtually indistinguishable from $|2 \sin(\pi x)|$. Note that $P_{q_5}(\alpha, -x/q_5)$ crosses the line at height 1 (dashed line) near $x = \frac{5}{6}$, as the initial heuristics suggested, but $P_{q_4}(\alpha, x/q_4)$ crosses this line at a much larger value of x near $x = 0.95$, misleadingly suggesting a larger choice of the corresponding Ostrowski coefficient in order to maximize the Sudler product.

and the Ostrowski coefficient maximizing the Sudler product remains at $\frac{5}{6}a_{k+1}$. The reason is that while a larger choice of b_k leads to a larger value of the k -th factor of the Sudler product in (13), a larger choice of b_k also leads to a larger negative value of ε_{k-1} , which in turn leads to a smaller value of the $(k-1)$ -st factor. If we try to choose a larger value of b_k for some k for which $(\log a_k)/a_{k+1}$ is large, then, astonishingly, the magnifying effect that this has on the k -th factor in (13) is *exactly* canceled out by the corresponding demagnifying effect on the $(k-1)$ -st factor, so that overall it turns out to be better to stick with $b_k \approx \frac{5}{6}a_{k+1}$. This is a very surprising effect, which is mentioned as a “remarkable cancellation” in the proof of Proposition 15(ii). We note in passing that there is a second unexpected cancellation in this paper, when the additive constant in the conclusion of Theorem 3 turns out to be zero in formula (59). In both cases, we cannot give a convincing heuristic explanation of why these cancellations occur.

2.2. Limit functions of shifted Sudler products. Aistleitner, Technau and Zafeiropoulos [Aistleitner et al. 2020] proved that for $\alpha = [0; \bar{a}]$ the function $P_{q_k}(\alpha, (-1)^k x/q_k)$ converges pointwise on \mathbb{R} as $k \rightarrow \infty$, and gave an explicit formula for the limit function $G_\alpha(x)$ in the form of an infinite product. They also observed experimentally that as the value of a increases the graph of $G_\alpha(x)$ starts to resemble that of $|2 \sin(\pi x)|$. The speed of convergence of $P_{q_k}(\alpha, (-1)^k x/q_k) \rightarrow G_\alpha(x)$ as $k \rightarrow \infty$ is very fast, so the graphs depicted in Figure 1 for $k = 4$ are practically indistinguishable from those of the corresponding limit functions $G_\alpha(x)$. In the present paper we develop a general framework to estimate $P_{q_k}(\alpha, (-1)^k x/q_k)$ in terms of a cotangent sum; see Proposition 12. This in particular allows us to quantify the deviation

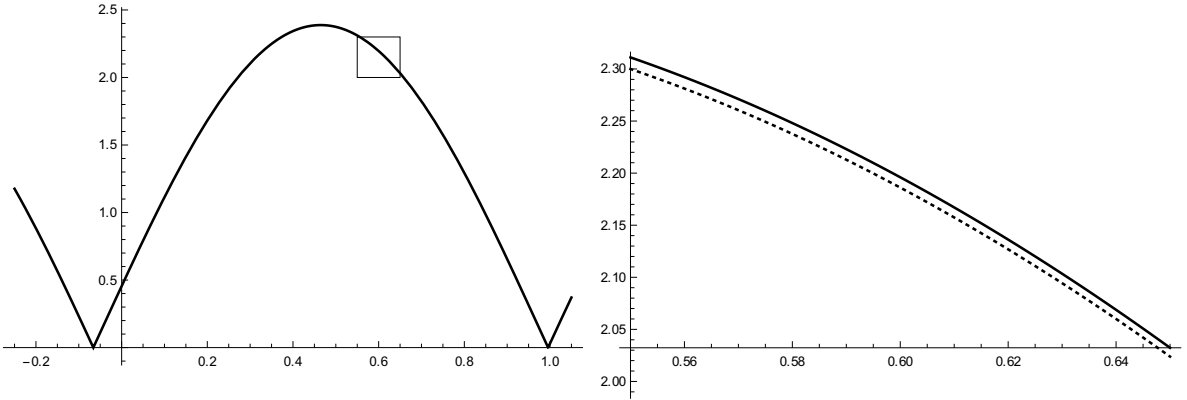

Figure 3. Left: The function $P_{q_k}(\alpha, (-1)^k x/q_k)$ for $k = 4$ and $\alpha = [0; \overline{15}]$, which virtually equals the corresponding limit function $G_\alpha(x)$. Right: We obtain an excellent approximation from the right-hand side of (15), leaving out the O-term. The difference is so small that it would be invisible on a full-scale plot as on the left, so we have zoomed into the small box indicated there to show the deviation between the two functions. The actual value of $P_{q_k}(\alpha, x/q_k)$ is plotted as a solid line, the approximation from (15) as a dotted line. Obviously we obtain a much better approximation than the crude $P_{q_k}(\alpha, (-1)^k x/q_k) \approx |2 \sin(\pi x)|$ of Figure 1.

of $P_{q_k}(\alpha, (-1)^k x/q_k)$ from $|2 \sin(\pi x)|$. For the particular case of $\alpha = [0; \bar{a}]$, when passing to the limit functions $G_\alpha(x)$ by letting $k \rightarrow \infty$, we obtain

$$G_\alpha(x) = |2 \sin(\pi x)| \cdot \left| 1 + \frac{C - D}{x + 1} \right| \cdot \left| 1 + \frac{C}{x} \right| \cdot \left| 1 + \frac{D}{x - 1} \right| \times \exp\left(C \left(\log \frac{a}{2\pi} - \frac{\Gamma'(2+x)}{\Gamma(2+x)} \right) + O\left(\frac{1 + \log a}{(2 - |x|)^2 a^2} \right) \right) \quad (15)$$

in the range $|x| \leq 2 - 2/a$, where Γ is the gamma function,

$$C = \frac{1}{\sqrt{a^2 + 4}} \quad \text{and} \quad D = \frac{\sqrt{a^2 + 4} - a}{2\sqrt{a^2 + 4}}.$$

In particular, we roughly have

$$G_\alpha(x) = |2 \sin(\pi x)| e^{(\log a)/a} + O\left(\frac{1}{a}\right) = |2 \sin(\pi x)| + O\left(\frac{1 + \log a}{a}\right), \quad |x| \leq 1.99, \quad (16)$$

but (15) is of course more precise. Observe that the effect of the factors $1 + (C - D)/(x + 1)$, $1 + C/x$, $1 + D/(x - 1)$ is that they shift the zeroes $-1, 0, 1$ of $|2 \sin(\pi x)|$ by roughly $(C - D) \sim 1/a$, $C \sim 1/a$, $D \sim 1/a^2$ to the left, respectively. The admissible range of x in the approximations (15) and (16) could be extended by the inclusion of more correction factors; however, in the context of Sudler products only shifts x in the range $x \in (-1, 1)$ can occur, so from our perspective there is no reason to aim at a wider range for x .

In a recent paper [Grepstad et al. 2022] the remarkable convergence property of $P_{q_k}(\alpha, (-1)^k x/q_k)$ was generalized to arbitrary quadratic irrationals $\alpha = [a_0; a_1, \dots, a_{k_0}, \overline{a_{k_0+1}, \dots, a_{k_0+p}}]$; we recall that the overline denotes period. The only difference is that in general we have p different limit functions $G_{\alpha,r}(x)$, $1 \leq r \leq p$, and $P_{q_k}(\alpha, (-1)^k x/q_k) \rightarrow G_{\alpha,r}(x)$ holds pointwise on \mathbb{R} as $k \rightarrow \infty$ along the arithmetic progression $k \in p\mathbb{N} + k_0 + r$. Generalizing (15), the following result states that all these limit functions are close to $|2 \sin(\pi x)|$ whenever the partial quotients of α are all large, and are roughly of similar order of magnitude; the latter property is measured by the parameter T .

Theorem 4. *Let $\alpha = [a_0; a_1, \dots, a_{k_0}, \overline{a_{k_0+1}, \dots, a_{k_0+p}}]$ be a quadratic irrational, and assume that*

$$\max_{1 \leq r \leq p} (\log a_{k_0+r})/a_{k_0+r+1} \leq T \quad \text{with some constant } T \geq 1.$$

For any $1 \leq r \leq p$ and any $|x| \leq \max\{1, 2 - 2/a_{k_0+r+1}\}$,

$$G_{\alpha,r}(x) = |2 \sin(\pi x)| \cdot \left| 1 + \frac{C_r - D_r}{x + 1} \right| \cdot \left| 1 + \frac{C_r}{x} \right| \cdot \left| 1 + \frac{D_r}{x - 1} \right| \\ \times \exp\left(C_r \left(\log \frac{a_{k_0+r}}{2\pi} - \frac{\Gamma'(2+x)}{\Gamma(2+x)} \right) + O\left(\frac{T + \log(a_{k_0+r-1} a_{k_0+r})}{(2 - |x|) a_{k_0+r} a_{k_0+r+1}} + \frac{T}{(2 - |x|)^2 a_{k_0+r+1}^2} \right) \right),$$

where Γ is the gamma function,

$$C_r = \lim_{m \rightarrow \infty} q_{k_0+r+mp} \|q_{k_0+r+mp} \alpha\| \quad \text{and} \quad D_r = \lim_{m \rightarrow \infty} q_{k_0+r-1+mp} \|q_{k_0+r+mp} \alpha\|.$$

Based on these results for quadratic irrationals with large partial quotients, it is not difficult to come up with the intuition that for a well-approximable irrational the corresponding limit function is precisely $|2 \sin(\pi x)|$.

Theorem 5. *Assume that $\sup_{k \geq 1} a_k = \infty$. Then*

$$P_{q_{k_m}}(\alpha, (-1)^{k_m} x/q_{k_m}) \rightarrow |2 \sin(\pi x)| \quad \text{as } m \rightarrow \infty$$

locally uniformly on \mathbb{R} for any increasing sequence of positive integers k_m such that

$$\frac{1 + \log \max_{1 \leq \ell \leq k_m} a_\ell}{a_{k_m+1}} \rightarrow 0 \quad \text{as } m \rightarrow \infty.$$

If in addition $\lim_{k \rightarrow \infty} (1 + \log a_k)/a_{k+1} = 0$, then the same holds along the full sequence $k_m = m$.

3. Approximation of shifted Sudler products

The main result of this section is Proposition 12 in Section 3.5 below, which is an approximation formula for the inner product over $0 \leq b \leq b_k - 1$ in the decomposition formula (13). As we will see, lower estimates are much more difficult to prove than upper estimates, especially when the points $bq_k \|q_k \alpha\| + \varepsilon_k(N)$ are close to 0 or 1, requiring a somewhat tedious case analysis throughout the paper. This is explained by the fact that $\log |2 \sin(\pi x)|$ is bounded above but not below, and has singularities at $x = 0$ and $x = 1$.

3.1. Continued fractions. We start by recalling some basic facts about continued fractions; see [Allouche and Shallit 2003; Rockett and Szűs 1992; Schmidt 1980] for background. The convergents satisfy the recursion $q_{k+1} = a_{k+1}q_k + q_{k-1}$ with initial conditions $q_0 = 1$, $q_1 = a_1$, and $p_{k+1} = a_{k+1}p_k + p_{k-1}$ with initial conditions $p_0 = a_0$, $p_1 = a_0a_1 + 1$. If either $k \geq 1$, or $k = 0$ and $a_1 > 1$, then the following hold:

- (i) By the best rational approximation property, $\|n\alpha\| \geq \|q_k\alpha\|$ for all $1 \leq n < q_{k+1}$.
- (ii) The integer closest to $q_k\alpha$ is p_k , and $(-1)^k(q_k\alpha - p_k) = \|q_k\alpha\|$.
- (iii) $1/(q_k\|q_k\alpha\|) = [a_{k+1}; a_{k+2}, a_{k+3}, \dots] + [0; a_k, a_{k-1}, \dots, a_1]$.

Note that (iii) follows easily from the well-known algebraic identity

$$[a_0; a_1, \dots, a_k, x] = \frac{p_kx + p_{k-1}}{q_kx + q_{k-1}}$$

with $x = [a_{k+1}; a_{k+2}, a_{k+3}, \dots]$, and the fact that $q_{k-1}/q_k = [0; a_k, a_{k-1}, \dots, a_1]$. In particular, (iii) implies that $1/(a_{k+1} + 2) \leq q_k\|q_k\alpha\| \leq 1/a_{k+1}$.

The recursion $\|q_{k+1}\alpha\| = -a_{k+1}\|q_k\alpha\| + \|q_{k-1}\alpha\|$ and the identity $|\alpha - p_k/q_k| + |\alpha - p_{k+1}/q_{k+1}| = 1/(q_kq_{k+1})$, in other words, $q_{k+1}\|q_k\alpha\| + q_k\|q_{k+1}\alpha\| = 1$, are also classical. Finally, recall the identity

$$q_{k+1}p_k - q_kp_{k+1} = (-1)^{k+1}, \quad k \geq 0. \tag{17}$$

The Ostrowski expansion of a nonnegative integer N is the unique representation $N = \sum_{k=0}^{K-1} b_kq_k$, where $0 \leq b_0 < a_1$ and $0 \leq b_k \leq a_{k+1}$ are integers which satisfy the rule that $b_{k-1} = 0$ whenever $b_k = a_{k+1}$.

We first prove a useful estimate for $\varepsilon_k(N)$, as defined in (12). Note that in the product formula (13) only those indices k appear for which $b_k \geq 1$; otherwise the inner product is empty, and by convention equals 1. For all intents and purposes, $\varepsilon_k(N)$ is thus only defined for those k for which $b_k \geq 1$.

Lemma 6. *Let $N = \sum_{k=0}^{K-1} b_kq_k$ be the Ostrowski expansion of a nonnegative integer. For any $k \geq 0$ such that $b_k \geq 1$,*

$$-1 < -q_k\|q_k\alpha\| + q_k\|q_{k+1}\alpha\| \leq \varepsilon_k(N) \leq q_k\|q_{k+1}\alpha\| < \frac{1}{2}. \tag{18}$$

If $b_{k+1} \leq (1 - \delta)a_{k+2}$ with some $\delta > 0$, then $\varepsilon_k(N) \geq -(1 - \frac{1}{3}\delta)q_k\|q_k\alpha\|$. If condition (6) holds, then $\varepsilon_k(N) \geq -(1 - 1/(e^T + 2))$ for any $k \geq k_0$ such that $b_k \geq 1$.

Proof. The estimate (18) was already observed in [Aistleitner and Borda 2022, Lemma 3]. To see the second claim, assume that $b_{k+1} \leq (1 - \delta)a_{k+2}$. Then

$$\begin{aligned} \varepsilon_k(N) &\geq -q_k(b_{k+1}\|q_{k+1}\alpha\| + b_{k+3}\|q_{k+3}\alpha\| + \dots) \\ &\geq -q_k((1 - \delta)a_{k+2}\|q_{k+1}\alpha\| + a_{k+4}\|q_{k+3}\alpha\| + \dots) \\ &= -q_k((1 - \delta)(\|q_k\alpha\| - \|q_{k+2}\alpha\|) + (\|q_{k+2}\alpha\| - \|q_{k+4}\alpha\|) + \dots) \\ &= -q_k((1 - \delta)\|q_k\alpha\| + \delta\|q_{k+2}\alpha\|). \end{aligned}$$

It is not difficult to see that $\|q_{k+2}\alpha\| \leq \frac{2}{3}\|q_k\alpha\|$. In particular, we have $\varepsilon_k(N) \geq -(1 - \frac{1}{3}\delta)q_k\|q_k\alpha\|$, as claimed.

To see the last claim, assume that (6) holds. We then have $q_k\|q_k\alpha\| \leq 1 - 1/(e^T + 2)$ for all $k \geq k_0$. Indeed, this trivially follows from $q_k\|q_k\alpha\| \leq 1/a_{k+1}$ if $a_{k+1} \geq 2$. If $a_{k+1} = 1$, then property (iii) of continued fractions above gives the more precise bound $1/(q_k\|q_k\alpha\|) \geq 1 + 1/(a_k + 1)$. By condition (6), here $a_k \leq e^T$, and $q_k\|q_k\alpha\| \leq 1 - 1/(e^T + 2)$ follows. Formula (18) thus gives $\varepsilon_k(N) \geq -q_k\|q_k\alpha\| \geq -(1 - 1/(e^T + 2))$, as claimed. □

3.2. A cotangent sum. The cotangent sum

$$\sum_{n=1}^{q_k-1} \frac{n}{q_k} \cot\left(\pi \frac{np_k}{q_k}\right) \tag{19}$$

will play an important role in our estimates for the shifted Sudler products. This sum is called the ‘‘Vasyunin sum’’ after the foundational work of Vasyunin [1995]. It is related to the Báez-Duarte–Nyman–Beurling criterion for the Riemann hypothesis; see in particular [Maier and Rassias 2019]. As we already observed in [Aistleitner and Borda 2022], a general result of Lubinsky [1999, Theorem 4.1] implies that for an arbitrary irrational α ,

$$\left| \sum_{n=1}^{q_k-1} \frac{n}{q_k} \cot\left(\pi \frac{np_k}{q_k}\right) \right| \ll (1 + \log \max_{1 \leq \ell \leq k} a_\ell)q_k. \tag{20}$$

A reciprocity formula of Bettin and Conrey [2013] provides a precise evaluation of (19). In particular, under assumption (6) we can isolate a main term; this main term is responsible for the exponential correction factor in Theorem 4. We now give an approximate evaluation of a shifted version of (19).

Lemma 7. *Assume (6). For any $k \geq 4$ and any $x \in (-1, 1)$,*

$$\sum_{n=1}^{q_k-1} \frac{n}{q_k} \cot\left(\pi \frac{np_k + (-1)^k x}{q_k}\right) = \frac{(-1)^k q_k}{\pi} \left(\log \frac{a_k}{2\pi} - \frac{\Gamma'(1+x)}{\Gamma(1+x)} + O\left(\frac{T + \log(a_{k-1}a_k)}{(1 - |x|)a_k}\right) \right) + O_\alpha(1),$$

where Γ is the gamma function.

Proof. Let

$$C_k(x) = \sum_{n=1}^{q_k-1} \frac{n}{q_k} \cot\left(\pi \frac{np_k + (-1)^k x}{q_k}\right)$$

denote the shifted cotangent sum in the statement of the lemma. We first prove the claim for $x = 0$, and then extend it to $x \in (-1, 1)$.

It follows from the identity (17) that the multiplicative inverse of $(-1)^{k+1}p_k$ modulo q_k is q_{k-1} . We also have the continued fraction expansion $q_{k-1}/q_k = [0; a_k, a_{k-1}, \dots, a_1]$. By a reciprocity formula

of Bettin and Conrey [2013] (see also [Bettin 2015, Proposition 1]), we have

$$\begin{aligned} \sum_{n=1}^{q_k-1} \frac{n}{q_k} \cot\left(\pi \frac{np_k}{q_k}\right) &= (-1)^{k+1} \sum_{n=1}^{q_k-1} \frac{n}{q_k} \cot\left(\pi \frac{n\overline{q_{k-1}}}{q_k}\right) \\ &= (-1)^{k+1} q_k \sum_{\ell=1}^k \frac{(-1)^\ell}{v_\ell} \left(\frac{1}{\pi v_\ell} + \psi\left(\frac{v_{\ell-1}}{v_\ell}\right)\right), \end{aligned} \tag{21}$$

where $\overline{q_{k-1}}$ is the multiplicative inverse of q_{k-1} modulo q_k , the fractions $u_\ell/v_\ell = [0; a_k, a_{k-1}, \dots, a_{k-\ell+1}]$ are the convergents of q_{k-1}/q_k (with the convention $v_0 = 1$), and $\psi : \mathbb{C} \setminus (-\infty, 0] \rightarrow \mathbb{C}$ is an analytic function with asymptotics

$$\psi(x) = \frac{\log(1/(2\pi x)) + \gamma}{\pi x} + O(\log(1/x))$$

as $x \rightarrow 0$ along the positive reals, with γ denoting the Euler–Mascheroni constant. The $\ell = 1$ term is

$$\begin{aligned} -\frac{1}{v_1} \left(\frac{1}{\pi v_1} + \psi\left(\frac{v_0}{v_1}\right)\right) &= -\frac{1}{a_k} \left(\frac{\log(a_k/(2\pi)) + \gamma}{\pi/a_k} + O(1 + \log a_k)\right) \\ &= -\frac{1}{\pi} \left(\log \frac{a_k}{2\pi} + \gamma + O\left(\frac{1 + \log a_k}{a_k}\right)\right). \end{aligned}$$

The terms $2 \leq \ell \leq k - k_0$ are negligible due to the assumption $(\log a_k)/a_{k+1} \leq T$:

$$\begin{aligned} \sum_{\ell=2}^{k-k_0} \frac{1}{v_\ell} \left|\frac{1}{\pi v_\ell} + \psi\left(\frac{v_{\ell-1}}{v_\ell}\right)\right| &\ll \sum_{\ell=2}^{k-k_0} \frac{1}{v_\ell} \cdot \frac{1 + \log(v_\ell/v_{\ell-1})}{v_{\ell-1}/v_\ell} \\ &\ll \sum_{\ell=2}^{k-k_0} \frac{1 + \log a_{k-\ell+1}}{v_{\ell-1}} \\ &\ll \frac{1 + \log a_{k-1}}{a_k} + \sum_{\ell=3}^{k-k_0} \frac{T}{v_{\ell-2}} \\ &\ll \frac{1 + \log a_{k-1}}{a_k} + \frac{T}{a_k}. \end{aligned}$$

Finally, the terms $k - k_0 + 1 \leq \ell \leq k$ satisfy

$$\sum_{\ell=k-k_0+1}^k \frac{1}{v_\ell} \left|\frac{1}{\pi v_\ell} + \psi\left(\frac{v_{\ell-1}}{v_\ell}\right)\right| \ll \sum_{\ell=k-k_0+1}^k \frac{1 + \log a_{k-\ell+1}}{v_{\ell-1}} \ll_\alpha \frac{1}{v_k} = \frac{1}{q_k}.$$

Using the previous three formulas in (21), we get

$$C_k(0) = \frac{(-1)^k q_k}{\pi} \left(\log \frac{a_k}{2\pi} + \gamma + O\left(\frac{T + \log(a_{k-1} a_k)}{a_k}\right)\right) + O_\alpha(1). \tag{22}$$

This proves the claim when $x = 0$; note that $-\Gamma'(1)/\Gamma(1) = \gamma$.

Next, let $x \in (-1, 1)$, and consider the derivative

$$C'_k(x) = \sum_{n=1}^{q_k-1} \frac{(-1)^{k+1} \pi n}{q_k^2 \sin^2(\pi((np_k + (-1)^k x)/q_k))} = \sum_{n=1}^{q_k-1} \frac{(-1)^{k+1} n}{\pi q_k^2 \|(n(-1)^k p_k + x)/q_k\|^2} + O(1). \tag{23}$$

In the second step we used the general estimate $\pi/\sin^2(\pi y) = 1/(\pi \|y\|^2) + O(1)$. We now isolate a small number of integers n which give the main contribution in (23). Recall once again that $q_{k-1} p_k \equiv (-1)^{k+1} \pmod{q_k}$. Let $0 < |a| \leq a_k$ be an integer. Then the solution of the congruence $n(-1)^k p_k \equiv a \pmod{q_k}$ is $n \equiv -aq_{k-1} \pmod{q_k}$; the unique representative of this residue class in $1 \leq n \leq q_k - 1$ is $n = q_k - aq_{k-1}$ if $1 \leq a \leq a_k$, and $n = -aq_{k-1}$ if $-a_k \leq a \leq -1$. The contribution of these $2a_k$ integers n in (23) is

$$\begin{aligned} & \frac{(-1)^{k+1}}{\pi} \left(\sum_{a=1}^{a_k} \frac{q_k - aq_{k-1}}{q_k^2 \|a/q_k + x/q_k\|^2} + \sum_{a=-a_k}^{-1} \frac{-aq_{k-1}}{q_k^2 \|a/q_k + x/q_k\|^2} \right) \\ &= \frac{(-1)^{k+1}}{\pi} \left(\sum_{a=1}^{a_k} \frac{q_k}{(a+x)^2} + \sum_{a=1}^{a_k} \left(\frac{aq_{k-1}}{(a-x)^2} - \frac{aq_{k-1}}{(a+x)^2} \right) \right) \\ &= \frac{(-1)^{k+1} q_k}{\pi} \sum_{a=1}^{\infty} \frac{1}{(a+x)^2} + O\left(\frac{q_k(1 + \log a_k)}{(1 - |x|)^2 a_k}\right). \end{aligned}$$

Note that we used the assumption $k \geq 4$ to ensure that $(a_k + 1)/q_k \leq \frac{1}{2}$. Since the contribution of all other integers n in (23) is

$$\ll \sum_{a_k < |a| \leq \frac{1}{2} q_k} \frac{1}{q_k(1 - |x|)^2 \|a/q_k\|^2} \ll \frac{q_k}{(1 - |x|)^2 a_k},$$

we get

$$C'_k(x) = \frac{(-1)^{k+1} q_k}{\pi} \sum_{a=1}^{\infty} \frac{1}{(a+x)^2} + O\left(\frac{q_k(1 + \log a_k)}{(1 - |x|)^2 a_k}\right).$$

By integrating and identifying the resulting infinite series as a special function we get

$$\begin{aligned} C_k(x) - C_k(0) &= \frac{(-1)^{k+1} q_k}{\pi} \sum_{a=1}^{\infty} \left(\frac{1}{a} - \frac{1}{a+x} \right) + O\left(\frac{q_k(1 + \log a_k)}{(1 - |x|) a_k}\right) \\ &= \frac{(-1)^{k+1} q_k}{\pi} \left(\gamma + \frac{\Gamma'(1+x)}{\Gamma(1+x)} + O\left(\frac{1 + \log a_k}{(1 - |x|) a_k}\right) \right), \end{aligned}$$

and the claim for general $x \in (-1, 1)$ follows from the special case (22). □

3.3. A modified cotangent sum. We will actually need a slightly modified version of the cotangent sum in Lemma 7, defined as

$$V_k(x) := \sum_{n=1}^{q_k-1} \sin(\pi n \|q_k \alpha\|/q_k) \cot\left(\pi \frac{n(-1)^k p_k + x}{q_k}\right). \tag{24}$$

Lemma 8. (i) For any $k \geq 1$, the derivative of $V_k(x)$ on the interval $(-1, 1)$ satisfies

$$V'_k(x) < 0 \quad \text{and} \quad |V'_k(x)| \ll \frac{1}{(1 - |x|)^2 a_{k+1}}.$$

(ii) For any $k \geq 1$,

$$|V_k(0)| \ll \frac{1 + \log \max_{1 \leq \ell \leq k} a_\ell}{a_{k+1}}.$$

(iii) Assume (6). For any $k \geq 4$ and any $x \in (-1, 1)$,

$$\frac{V_k(x)}{q_k \|q_k \alpha\|} = \log \frac{a_k}{2\pi} - \frac{\Gamma'(1+x)}{\Gamma(1+x)} + O\left(\frac{T + \log(a_{k-1} a_k)}{(1 - |x|) a_k}\right) + O_\alpha\left(\frac{1}{q_k}\right).$$

In particular,

$$V_k(x) = \frac{\log a_k}{a_{k+1}} + O\left(\frac{T}{(1 - |x|) a_{k+1}}\right) + O_\alpha\left(\frac{1}{q_{k+1}}\right).$$

Proof. Let $x \in (-1, 1)$. Clearly,

$$V'_k(x) = \sum_{n=1}^{q_k-1} \sin(\pi n \|q_k \alpha\| / q_k) \frac{-\pi}{q_k \sin^2(\pi(n(-1)^k p_k / q_k + x / q_k))} < 0.$$

By the general inequality $|\sin(\pi y)| \geq 2\|y\|$ and

$$\|n(-1)^k p_k / q_k + x / q_k\| \geq (1 - |x|) \|n p_k / q_k\|,$$

we also have

$$|V'_k(x)| \ll \sum_{n=1}^{q_k-1} \frac{\|q_k \alpha\|}{q_k (1 - |x|)^2 \|n p_k / q_k\|^2} \ll \frac{q_k \|q_k \alpha\|}{(1 - |x|)^2} \ll \frac{1}{(1 - |x|)^2 a_{k+1}}.$$

In the second step we used the fact that as n runs in the interval $1 \leq n \leq q_k - 1$, the integers $n p_k$ attain each nonzero residue class modulo q_k exactly once. This finishes the proof of (i).

Next, note that the general estimate $\sin y = y + O(|y|^3)$ implies the error of replacing $\sin(\pi n \|q_k \alpha\| / q_k)$ by $\pi n \|q_k \alpha\| / q_k$ in the definition of $V_k(x)$ is

$$\ll \sum_{n=1}^{q_k-1} \frac{n^3 \|q_k \alpha\|^3}{q_k^3} \left| \cot\left(\pi \frac{n(-1)^k p_k + x}{q_k}\right) \right| \ll \sum_{n=1}^{q_k-1} \frac{\|q_k \alpha\|^3}{(1 - |x|) \|n p_k / q_k\|} \ll \frac{\|q_k \alpha\|^3 q_k \log q_k}{1 - |x|},$$

and hence

$$V_k(x) = \pi \|q_k \alpha\| \sum_{n=1}^{q_k-1} \frac{n}{q_k} \cot\left(\pi \frac{n(-1)^k p_k + x}{q_k}\right) + O\left(\frac{\|q_k \alpha\|^3 q_k \log q_k}{1 - |x|}\right).$$

Claims (ii) and (iii) thus follow from (20) and Lemma 7, respectively. □

3.4. The reflection and transfer principles. In our previous paper [Aistleitner and Borda 2022] we showed the useful identity

$$P_N(p/q) \cdot P_{q-N-1}(p/q) = q$$

for any reduced fraction p/q and any integer $0 \leq N < q$. We also proved that

$$|\log P_N(p_k/q_k) - \log P_N(\alpha)| \ll \frac{1 + \log \max_{1 \leq \ell \leq k} a_\ell}{a_{k+1}}$$

for an arbitrary irrational α and all $0 \leq N < q_k$. We called these results the reflection and transfer principles, respectively; the latter terminology comes from the fact that it helps transfer results between rational and irrational settings. In this section we establish similar principles for shifted Sudler products.

Proposition 9. *Let p/q be a reduced fraction. For any $0 \leq N < q$ and any $x \in \mathbb{R}$,*

$$P_N(p/q, x) \cdot P_{q-N-1}(p/q, -x) = \begin{cases} |\sin(\pi qx)|/|\sin(\pi x)| & \text{if } x \notin \mathbb{Z}, \\ q & \text{if } x \in \mathbb{Z}. \end{cases} \tag{25}$$

In particular, for any $x \in \mathbb{R}$,

$$P_{q-1}(p/q, x) = \begin{cases} |\sin(\pi qx)|/|\sin(\pi x)| & \text{if } x \notin \mathbb{Z}, \\ q & \text{if } x \in \mathbb{Z}. \end{cases} \tag{26}$$

Proof. For a given $x \in \mathbb{R}$ consider the factorization

$$t^q - e^{2\pi i qx} = (t - e^{2\pi i x}) \prod_{j=1}^{q-1} (t - e^{2\pi i(j/q+x)}).$$

Dividing both sides by $(t - e^{2\pi i x})$ and letting $t \rightarrow 1$, we get

$$\prod_{j=1}^{q-1} (1 - e^{2\pi i(j/q+x)}) = \begin{cases} (1 - e^{2\pi i qx})/(1 - e^{2\pi i x}) & \text{if } x \notin \mathbb{Z}, \\ q & \text{if } x \in \mathbb{Z}. \end{cases}$$

Therefore

$$P_{q-1}(p/q, x) = \prod_{n=1}^{q-1} |1 - e^{2\pi i(np/q+x)}| = \prod_{j=1}^{q-1} |1 - e^{2\pi i(j/q+x)}| = \begin{cases} |\sin(\pi qx)|/|\sin(\pi x)| & \text{if } x \notin \mathbb{Z}, \\ q & \text{if } x \in \mathbb{Z}, \end{cases}$$

as claimed in (26). Next, let $0 \leq N < q$. By the definition of shifted Sudler products and the previous formula,

$$P_N(p/q, x) \cdot \prod_{n=N+1}^{q-1} |2 \sin(\pi(np/q + x))| = P_{q-1}(p/q, x) = \begin{cases} |\sin(\pi qx)|/|\sin(\pi x)| & \text{if } x \notin \mathbb{Z}, \\ q & \text{if } x \in \mathbb{Z}. \end{cases}$$

A simple reindexing shows that here

$$\prod_{n=N+1}^{q-1} |2 \sin(\pi(np/q + x))| = \prod_{j=1}^{q-N-1} |2 \sin(\pi((q-j)p/q + x))| = P_{q-N-1}(p/q, -x),$$

which proves (25). □

Corollary 10. *Let $k \geq 1$ and $0 \leq M < q_k$ be integers, and define*

$$B_{k,M}(x) := \log \frac{P_M(\alpha, (-1)^k x/q_k)}{P_M(p_k/q_k, (-1)^k x/q_k)} - \sum_{n=1}^M \sin(\pi n \|q_k \alpha\|/q_k) \cot\left(\pi \frac{n(-1)^k p_k + x}{q_k}\right). \quad (27)$$

Then

$$\log P_{q_k}(\alpha, (-1)^k x/q_k) = \log\left(|2 \sin(\pi(\|q_k \alpha\| + x/q_k))| \frac{|\sin(\pi x)|}{|\sin(\pi x/q_k)|}\right) + V_k(x) + B_{k,q_k-1}(x),$$

with the convention $|\sin(\pi x)|/|\sin(\pi x/q_k)| = q_k$ when $x/q_k \in \mathbb{Z}$.

Proof. By the definitions (27) of $B_{k,M}(x)$ and (24) of $V_k(x)$,

$$\log P_{q_k-1}(\alpha, (-1)^k x/q_k) = \log P_{q_k-1}(p_k/q_k, (-1)^k x/q_k) + V_k(x) + B_{k,q_k-1}(x). \quad (28)$$

Using the identity (26), here

$$\log P_{q_k-1}(p_k/q_k, (-1)^k x/q_k) = \log \frac{|\sin(\pi x)|}{|\sin(\pi x/q_k)|}.$$

Adding $\log|2 \sin(\pi(q_k \alpha + (-1)^k x/q_k))| = \log|2 \sin(\pi(\|q_k \alpha\| + x/q_k))|$ to both sides of (28), the claim follows. \square

In the claim of [Corollary 10](#) we consider $V_k(x)$ to be a first-order correction term, and $B_{k,q_k-1}(x)$ to be an error term. The following proposition gives estimates for $B_{k,M}(x)$; we call it the transfer principle for shifted Sudler products. In fact, in the present paper we will only use it with $M = q_k - 1$.

Proposition 11. (i) *Let $k \geq 1$ and $0 \leq M < q_k$ be integers, and assume that $q_k \|q_k \alpha\| \leq 1 - c_k$ and $-1 < x \leq 1 - q_k \|q_k \alpha\|/(1 - c_k)$ for some c_k such that $10/q_k^2 \leq c_k < 1$. Then*

$$-C \frac{\log(4/c_k)}{(1 - |x|)^2 a_{k+1}^2} \leq B_{k,M}(x) \leq C \frac{1}{a_{k+1}^2 q_k}$$

with a universal constant $C > 0$.

(ii) *Let $N = \sum_{k=0}^{K-1} b_k q_k$ be the Ostrowski expansion of a nonnegative integer. For any $1 \leq k \leq K - 1$, any $0 \leq M < q_k$ and any $0 \leq b \leq b_k - 1$, we have*

$$B_{k,M}(b q_k \|q_k \alpha\| + \varepsilon_k(N)) \leq C \frac{1}{a_{k+1}^2 q_k}$$

with a universal constant $C > 0$.

Proof of Proposition 11 (i). Using trigonometric identities we can write

$$\frac{P_M(\alpha, (-1)^k x/q_k)}{P_M(p_k/q_k, (-1)^k x/q_k)} = \left| \prod_{n=1}^M \frac{\sin(\pi(n\alpha + (-1)^k x/q_k))}{\sin(\pi(np_k/q_k + (-1)^k x/q_k))} \right| = \left| \prod_{n=1}^M (1 + x_n + y_n) \right|, \quad (29)$$

where

$$x_n := \cos(\pi n(\alpha - p_k/q_k)) - 1 = \cos(\pi n \|q_k \alpha\|/q_k) - 1$$

and

$$\begin{aligned} y_n &:= \sin(\pi n(\alpha - p_k/q_k)) \cot(\pi(np_k/q_k + (-1)^k x/q_k)) \\ &= \sin(\pi n\|q_k\alpha\|/q_k) \cot(\pi(n(-1)^k p_k/q_k + x/q_k)). \end{aligned}$$

Assume first that $0 \leq x \leq 1 - q_k\|q_k\alpha\|/(1 - c_k)$. From the Taylor expansions of sine and cosine, and the estimate

$$\|n(-1)^k p_k/q_k + x/q_k\| \geq (1 - x)\|np_k/q_k\| \geq (1 - x)/q_k, \tag{30}$$

we get that for any $0 < n < q_k$,

$$|x_n| \leq \frac{\pi^2 n^2 \|q_k\alpha\|^2}{2q_k^2} \leq \frac{1}{2}c_k \tag{31}$$

and

$$\begin{aligned} |y_n| &\leq \frac{\sin(\pi n\|q_k\alpha\|/q_k)}{|\sin(\pi(n(-1)^k p_k/q_k + x/q_k))|} \leq \frac{\pi\|q_k\alpha\|}{\pi(1-x)/q_k - \pi^3(1-x)^3/(6q_k^3)} \\ &\leq \frac{q_k\|q_k\alpha\|}{1-x} \cdot \frac{1}{1 - \pi^2/(6q_k^2)} \\ &\leq (1 - c_k) \frac{1}{1 - \pi^2/(6q_k^2)} \\ &\leq 1 - \frac{3}{4}c_k. \end{aligned}$$

The point is that each factor in (29) is bounded away from zero, as $1 + x_n + y_n \geq \frac{1}{4}c_k$; in particular, the absolute values in (29) can be removed. Since y_n is a decreasing function of $x \in (-1, 1)$, the same holds if $-1 < x < 0$.

Observe that for any $t \geq -1 + \frac{1}{4}c_k$,

$$e^{t-2t^2 \log(4/c_k)} \leq 1 + t \leq e^t.$$

Indeed, one readily verifies that the function $e^{-t+2t^2 \log(4/c_k)}(1 + t)$ attains its minimum on the interval $[-1 + \frac{1}{4}c_k, \infty)$ at $t = 0$. Applying this estimate with $t = x_n + y_n$ in each factor of (29), we obtain

$$\begin{aligned} \exp\left(\sum_{n=1}^M (x_n + y_n) - 2 \sum_{n=1}^M (x_n + y_n)^2 \log(4/c_k)\right) &\leq \frac{P_M(\alpha, (-1)^k x/q_k)}{P_M(p_k/q_k, (-1)^k x/q_k)} \\ &\leq \exp\left(\sum_{n=1}^M (x_n + y_n)\right). \end{aligned} \tag{32}$$

By (31), we have

$$\sum_{n=1}^M |x_n| \ll \sum_{n=1}^M \frac{1}{a_{k+1}^2 q_k^2} \ll \frac{1}{a_{k+1}^2 q_k} \quad \text{and} \quad \sum_{n=1}^M x_n^2 \log(4/c_k) \ll \sum_{n=1}^M \frac{\log(4/c_k)}{a_{k+1}^4 q_k^4} \ll \frac{\log(4/c_k)}{a_{k+1}^4 q_k^3}.$$

From (30) we get

$$|y_n| \leq \frac{\sin(\pi n\|q_k\alpha\|/q_k)}{|\sin(\pi(n(-1)^k p_k/q_k + x/q_k))|} \ll \frac{\|q_k\alpha\|}{(1 - |x|)\|np_k/q_k\|},$$

and hence

$$\sum_{n=1}^M y_n^2 \log(4/c_k) \ll \sum_{n=1}^M \frac{\|q_k \alpha\|^2 \log(4/c_k)}{(1 - |x|)^2 \|np_k/q_k\|^2} \ll \frac{\log(4/c_k)}{(1 - |x|)^2 a_{k+1}^2}.$$

The estimate (32) thus simplifies as

$$-C \frac{\log(4/c_k)}{(1 - |x|)^2 a_{k+1}^2} \leq \log \frac{P_M(\alpha, (-1)^k x/q_k)}{P_M(p_k/q_k, (-1)^k x/q_k)} - \sum_{n=1}^M y_n \leq C \frac{1}{a_{k+1}^2 q_k}$$

with some universal constant $C > 0$, which proves the claim. □

Proof of Proposition 11 (ii). We argue as in the previous proof. First, we claim that in (29) the absolute values can be removed at the point $x = bq_k \|q_k \alpha\| + \varepsilon_k(N)$. To see this, note that

$$n\alpha + (-1)^k x/q_k = (-1)^k ((n + bq_k) \|q_k \alpha\| + \varepsilon_k(N))/q_k + np_k/q_k.$$

By Lemma 6, here

$$(n + bq_k) \|q_k \alpha\| + \varepsilon_k(N) \leq (b + 1)q_k \|q_k \alpha\| + q_k \|q_{k+1} \alpha\| < q_{k+1} \|q_k \alpha\| + q_k \|q_{k+1} \alpha\| = 1,$$

and also

$$(n + bq_k) \|q_k \alpha\| + \varepsilon_k(N) \geq \varepsilon_k(N) > -1.$$

Consequently, $|n\alpha + (-1)^k x/q_k - np_k/q_k| < 1/q_k$. We clearly also have $|x| < 1$, and therefore the points $n\alpha + (-1)^k x/q_k$ and $np_k/q_k + (-1)^k x/q_k$ both lie in the open interval centered at $np_k/q_k \notin \mathbb{Z}$ of radius $1/q_k$. Since the function $\sin(\pi y)$ does not have a zero in this interval, we have

$$\frac{\sin(\pi(n\alpha + (-1)^k x/q_k))}{\sin(\pi(np_k/q_k + (-1)^k x/q_k))} > 0.$$

Hence (29) indeed holds without the absolute values; that is,

$$\frac{P_M(\alpha, (-1)^k x/q_k)}{P_M(p_k/q_k, (-1)^k x/q_k)} = \prod_{n=1}^M \frac{\sin(\pi(n\alpha + (-1)^k x/q_k))}{\sin(\pi(np_k/q_k + (-1)^k x/q_k))} = \prod_{n=1}^M (1 + x_n + y_n)$$

with x_n, y_n as in the previous proof. The upper bound

$$\frac{P_M(\alpha, (-1)^k x/q_k)}{P_M(p_k/q_k, (-1)^k x/q_k)} \exp\left(-\sum_{n=1}^M y_n\right) \leq \exp\left(\sum_{n=1}^M x_n\right) \leq \exp\left(C \frac{1}{a_{k+1}^2 q_k}\right)$$

immediately follows, as claimed. □

3.5. Key estimate for shifted Sudler products. We emphasize that in the following proposition we do not assume condition (6), so it could serve as a starting point for various generalizations of the results in

this paper. In the proofs of our theorems, condition (6) will ensure that in the claim of the proposition the contribution of the cotangent sum (the sum expressed in terms of $V_k(x)$) is negligible compared to the sum which is expressed in terms of $\log |2 \sin(\pi x)|$.

Proposition 12. *Let $N = \sum_{k=0}^{K-1} b_k q_k$ be the Ostrowski expansion of a nonnegative integer. For any $k \geq 1$ such that $b_k \geq 1$,*

$$\begin{aligned} \sum_{b=0}^{b_k-1} \log P_{q_k}(\alpha, (-1)^k (b q_k \|q_k \alpha\| + \varepsilon_k(N))/q_k) \\ = \sum_{b=1}^{b_k-1} \log |2 \sin(\pi (b q_k \|q_k \alpha\| + \varepsilon_k(N)))| + \sum_{b=0}^{b_k-1} V_k(b q_k \|q_k \alpha\| + \varepsilon_k(N)) \\ + \log(2\pi (b_k q_k \|q_k \alpha\| + \varepsilon_k(N))) + E_k(N), \end{aligned}$$

where $E_k(N) \leq C/(a_{k+1} q_k)$ with a universal constant $C > 0$. If in addition $k \geq 20 \log(20/\delta)$, $b_k \leq (1 - \delta)a_{k+1}$ and $q_k \|q_k \alpha\| \leq 1 - \delta$ with some $\delta > 0$, then $E_k(N) \geq -C(\log(2/\delta)/\delta^2)(1/a_{k+1} + 1/q_k^2)$ with a universal constant $C > 0$.

Proof. For the sake of readability, put $f(x) = |2 \sin(\pi x)|$ and $\varepsilon_k = \varepsilon_k(N)$. Applying Corollary 10 at $x = b q_k \|q_k \alpha\| + \varepsilon_k$ and summing over $0 \leq b \leq b_k - 1$, we get

$$\begin{aligned} \sum_{b=0}^{b_k-1} \log P_{q_k}(\alpha, (-1)^k (b q_k \|q_k \alpha\| + \varepsilon_k)/q_k) \\ = \sum_{b=0}^{b_k-1} \log \left(f((b+1)\|q_k \alpha\| + \varepsilon_k/q_k) \frac{f(b q_k \|q_k \alpha\| + \varepsilon_k)}{f(b\|q_k \alpha\| + \varepsilon_k/q_k)} \right) + \sum_{b=0}^{b_k-1} V_k(b q_k \|q_k \alpha\| + \varepsilon_k) \\ + \sum_{b=0}^{b_k-1} B_{k,q_k-1}(b q_k \|q_k \alpha\| + \varepsilon_k). \end{aligned}$$

Observe that the first sum on the right-hand side has a telescoping part. Peeling off the $b = 0$ term, we obtain

$$\begin{aligned} \sum_{b=0}^{b_k-1} \log P_{q_k}(\alpha, (-1)^k (b q_k \|q_k \alpha\| + \varepsilon_k)/q_k) \\ = \sum_{b=1}^{b_k-1} \log f(b q_k \|q_k \alpha\| + \varepsilon_k) + \sum_{b=0}^{b_k-1} V_k(b q_k \|q_k \alpha\| + \varepsilon_k) + \log \left(f(b_k \|q_k \alpha\| + \varepsilon_k/q_k) \frac{f(\varepsilon_k)}{f(\varepsilon_k/q_k)} \right) \\ + \sum_{b=0}^{b_k-1} B_{k,q_k-1}(b q_k \|q_k \alpha\| + \varepsilon_k), \end{aligned}$$

with the convention that $f(\varepsilon_k)/f(\varepsilon_k/q_k) = q_k$ if $\varepsilon_k = 0$. It remains to estimate the error term

$$E_k(N) := \log \left(\frac{f(b_k \|q_k \alpha\| + \varepsilon_k/q_k)}{2\pi (b_k q_k \|q_k \alpha\| + \varepsilon_k)} \cdot \frac{f(\varepsilon_k)}{f(\varepsilon_k/q_k)} \right) + \sum_{b=0}^{b_k-1} B_{k,q_k-1}(b q_k \|q_k \alpha\| + \varepsilon_k).$$

First, we prove the upper bound for $E_k(N)$. Using $B_{k,q_{k-1}}(bq_k\|q_k\alpha\| + \varepsilon_k) \leq C/(a_{k+1}^2q_k)$ from [Proposition 11\(ii\)](#) and elementary estimates for the sine function,

$$E_k(N) \leq \log\left(\frac{f(b_k\|q_k\alpha\| + \varepsilon_k/q_k)}{2\pi(b_kq_k\|q_k\alpha\| + \varepsilon_k)} \cdot q_k\right) + \sum_{b=0}^{b_k-1} \frac{C}{a_{k+1}^2q_k} \leq \frac{C}{a_{k+1}q_k},$$

as claimed.

Next, assume, in addition, that $k \geq 20 \log(20/\delta)$, $b_k \leq (1 - \delta)a_{k+1}$ and $q_k\|q_k\alpha\| \leq 1 - \delta$. By [Lemma 6](#), for any $0 \leq b \leq b_k - 1$, the point $x = bq_k\|q_k\alpha\| + \varepsilon_k$ satisfies

$$\begin{aligned} x &\leq ((1 - \delta)a_{k+1} - 1)q_k\|q_k\alpha\| + q_k\|q_{k+1}\alpha\| \\ &= ((1 - \delta)a_{k+1} - 1)q_k\|q_k\alpha\| + 1 - q_{k+1}\|q_k\alpha\| \\ &\leq 1 - (1 + \delta)q_k\|q_k\alpha\|, \end{aligned}$$

and also

$$x \geq \varepsilon_k \geq -q_k\|q_k\alpha\| \geq -(1 - \delta).$$

Hence we can apply [Proposition 11\(i\)](#) with $c_k = \delta/(1 + \delta)$. Note that the assumption $k \geq 20 \log(20/\delta)$ ensures that $c_k \geq 10/q_k^2$. Since we also have $|x| \leq 1 - \delta$, we obtain

$$\sum_{b=0}^{b_k-1} B_{k,q_{k-1}}(bq_k\|q_k\alpha\| + \varepsilon_k) \geq \sum_{b=0}^{b_k-1} \left(-\frac{C \log(4/c_k)}{\delta^2 a_{k+1}^2}\right) \geq -\frac{C \log(2/\delta)}{\delta^2 a_{k+1}}.$$

Finally, using the general estimate $\sin y = y(1 + O(y^2))$ we get

$$f(b_k\|q_k\alpha\| + \varepsilon_k/q_k) = 2\pi(b_k\|q_k\alpha\| + \varepsilon_k/q_k)(1 + O(1/q_k^2))$$

and

$$\frac{f(\varepsilon_k)}{f(\varepsilon_k/q_k)} = q_k(1 + O(\varepsilon_k^2)) = q_k(1 + O(1/a_{k+1}^2)).$$

Therefore

$$\log\left(\frac{f(b_k\|q_k\alpha\| + \varepsilon_k/q_k)}{2\pi(b_kq_k\|q_k\alpha\| + \varepsilon_k)} \cdot \frac{f(\varepsilon_k)}{f(\varepsilon_k/q_k)}\right) = \log(1 + O(1/a_{k+1}^2 + 1/q_k^2)) = O(1/a_{k+1}^2 + 1/q_k^2).$$

Altogether we get $E_k(N) \geq -C(\log(2/\delta)/\delta^2)(1/a_{k+1} + 1/q_k^2)$, as claimed. □

4. Proof of [Theorem 1](#)

Throughout this section we assume that [\(6\)](#) holds with some k_0 , $T \geq 1$. Let $\delta_T > 0$ be a small enough constant depending only on T ; for the convenience of the reader we mention that $\delta_T = \min\{1/(4\pi e^{2T}), \frac{1}{100}\}$ is a suitable choice. We may assume that $k_0 \geq 20 \log(20/\delta_T)$. Let us now introduce a sequence which will play a key role in the proof of [Theorem 1](#).

Definition. Let N be a nonnegative integer with Ostrowski expansion $N = \sum_{k=0}^{K-1} b_k q_k$. For any $k_0 \leq k \leq K - 1$, let $u_k(N) = 1$ if $b_k = 0$, and let

$$u_k(N) = \left(\prod_{b=1}^{b_k-1} |2 \sin(\pi(bq_k \|q_k \alpha\| + \varepsilon_k(N)))| \right) \exp\left(\sum_{b=0}^{b_k-1} V_k(bq_k \|q_k \alpha\| + \varepsilon_k(N)) \right) \times 2\pi(b_k q_k \|q_k \alpha\| + \varepsilon_k(N))$$

if $b_k \geq 1$. Finally, let $U_N = \prod_{k=k_0}^{K-1} u_k(N)$.

Summarizing the results of the previous section, we can rephrase [Proposition 12](#) in terms of U_N .

Proposition 13. For any nonnegative integer with Ostrowski expansion $N = \sum_{k=0}^{K-1} b_k q_k$, we have

$$\log P_N(\alpha) = \log U_N - \sum_{k=k_0}^{K-1} F_k(N) + O_T\left(\sum_{k=1}^K \frac{1}{a_k}\right) + O_\alpha(1)$$

with some $F_k(N)$ satisfying $F_k(N) \geq 0$ for all $k_0 \leq k \leq K - 1$, and $F_k(N) = 0$ for all $k_0 \leq k \leq K - 1$ such that $b_k \leq (1 - \delta_T)a_{k+1}$.

We have thus reduced the problem of estimating $P_N(\alpha)$ to U_N , and the rest of the section is devoted to studying the latter sequence. Our main strategy will be to start with an arbitrary nonnegative integer $N = \sum_{k=0}^{K-1} b_k q_k$, and to change its Ostrowski coefficients one by one; we call such a transformation a *projection*. After finitely many projections we will transform all Ostrowski coefficients b_k with $k_0 \leq k \leq K - 1$ to $b_k^* = \lfloor \frac{5}{6} a_{k+1} \rfloor$. Keeping track of the effect of each projection, we will be able to compare U_N to U_{N^*} .

Proof of Proposition 13. Let $E_k(N)$ be as in [Proposition 12](#) if $b_k \geq 1$, and $E_k(N) = 0$ if $b_k = 0$. By the definition earlier in this section, for any $k_0 \leq k \leq K - 1$ we have

$$\prod_{b=0}^{b_k-1} P_{q_k}(\alpha, (-1)^k(bq_k \|q_k \alpha\| + \varepsilon_k(N))/q_k) = u_k(N)e^{E_k(N)},$$

and hence from the factorization [\(13\)](#) we get

$$P_N(\alpha) = \left(\prod_{k=0}^{k_0-1} \prod_{b=0}^{b_k-1} P_{q_k}(\alpha, (-1)^k(bq_k \|q_k \alpha\| + \varepsilon_k(N))/q_k) \right) U_N \prod_{k=k_0}^{K-1} e^{E_k(N)}. \tag{33}$$

We start by finding upper and lower bounds for the first factor independent of N . For an upper bound, simply use $P_{q_k}(\alpha, x) \leq 2^{q_k}$ to get

$$\prod_{k=0}^{k_0-1} \prod_{b=0}^{b_k-1} P_{q_k}(\alpha, (-1)^k(bq_k \|q_k \alpha\| + \varepsilon_k(N))/q_k) \leq 2^{q_1 + \dots + q_{k_0}} \ll_\alpha 1.$$

To see a lower bound, let $0 \leq k \leq k_0 - 1$ and $0 \leq b \leq b_k - 1$. Then

$$P_{q_k}(\alpha, (-1)^k(bq_k\|q_k\alpha\| + \varepsilon_k(N))/q_k) = \prod_{n=1}^{q_k} |2 \sin(\pi((n + bq_k)\alpha + (-1)^k \varepsilon_k(N)/q_k))|.$$

Here $(n + bq_k) \leq q_k + (a_{k+1} - 1)q_k < q_{k+1}$, and thus by the best rational approximation property and Lemma 6,

$$\|(n + bq_k)\alpha + (-1)^k \varepsilon_k(N)/q_k\| \geq \|(n + bq_k)\alpha\| - |\varepsilon_k(N)|/q_k \geq \|q_k\alpha\| - \|q_{k+1}\alpha\|.$$

It follows that $\|(n + bq_k)\alpha + (-1)^k \varepsilon_k(N)/q_k\| \gg_\alpha 1$, and hence

$$P_{q_k}(\alpha, (-1)^k(bq_k\|q_k\alpha\| + \varepsilon_k(N))/q_k) \gg_\alpha 1.$$

The first factor in (33) is thus both $\ll_\alpha 1$ and $\gg_\alpha 1$, so

$$\log P_N(\alpha) = \log U_N + \sum_{k=k_0}^{K-1} E_k(N) + O_\alpha(1).$$

By Proposition 12, here $E_k(N) \leq C/(a_{k+1}q_k)$ for all $k_0 \leq k \leq K - 1$, and $E_k(N) \geq -C(\log(2/\delta_T)/\delta_T^2) \times (1/a_{k+1} + 1/q_k^2)$ for all $k_0 \leq k \leq K - 1$ such that $b_k \leq (1 - \delta_T)a_{k+1}$ with a universal constant $C > 0$. Let $F_k(N) = \max\{-E_k(N), 0\}$ if $b_k > (1 - \delta_T)a_{k+1}$, and $F_k(N) = 0$ otherwise. Then

$$F_k(N) = -E_k(N) + O_T\left(\frac{1}{a_{k+1}} + \frac{1}{q_k^2}\right)$$

for all $k_0 \leq k \leq K - 1$, and the claim follows. □

4.1. Key estimate for projections. We now introduce the main technical tool in the proof of Theorem 1, and establish its key property.

Definition. Let $N = \sum_{k=0}^{K-1} b_k q_k$ be the Ostrowski expansion of a nonnegative integer, and let $k_0 \leq m \leq K - 1$ and $0 \leq B \leq (1 - \delta_T)a_{m+1}$ be integers. The projection of N with respect to the index m and the integer B is $\text{proj}_{m,B}(N) := N' = \sum_{k=0}^{K-1} b'_k q_k$, where $b'_k = b_k$ for all $k \neq m$, and $b'_m = B$.

Proposition 14. Let $N = \sum_{k=0}^{K-1} b_k q_k$ be the Ostrowski expansion of a nonnegative integer, and let $k_0 \leq m \leq K - 1$ and $0 \leq B \leq (1 - \delta_T)a_{m+1}$ be integers. Assume that $b_k \leq (1 - \delta_T)a_{k+1}$ for all $k_0 \leq k < m$. If $m > k_0$, then $\text{proj}_{m,B}(N) = N'$ satisfies

$$\log U_{N'} - \log U_N \geq \log u_m(N') - \log u_m(N) - (\log(b_{m-1} + 1)) \frac{b'_m - b_m}{a_{m+1}} - O_T\left(\frac{|b'_m - b_m|}{a_{m+1}}\right). \tag{34}$$

If $m > k_0$ and $b_m \leq (1 - \delta_T)a_{m+1}$, then (34) holds with equality. If $m = k_0$, then (34) with the term $-(\log(b_{m-1} + 1))(b'_m - b_m)/(a_{m-1})$ removed holds with equality.

Proof. For the sake of readability, let $f(x) = |2 \sin(\pi x)|$. By definition (12), we have

$$\varepsilon_k(N') - \varepsilon_k(N) = (-1)^{k+m}(b'_m - b_m)q_k\|q_m\alpha\| \quad \text{for all } k_0 \leq k < m, \tag{35}$$

and $\varepsilon_k(N') = \varepsilon_k(N)$ for all $m \leq k \leq K - 1$. Recalling the definition on page 691, it follows that $u_k(N') = u_k(N)$ for all $m < k \leq K - 1$, and hence

$$\log U_{N'} - \log U_N = \log u_m(N') - \log u_m(N) + \sum_{k=k_0}^{m-1} (\log u_k(N') - \log u_k(N)). \tag{36}$$

Let $k_0 \leq k \leq m - 1$, and consider the corresponding term in the sum on the right-hand side of (36). If $b'_k = b_k = 0$, then $\log u_k(N') = \log u_k(N) = 0$. Otherwise,

$$\begin{aligned} \log u_k(N') - \log u_k(N) &= \sum_{b=1}^{b_k-1} \log \frac{f(bq_k \|q_k \alpha\| + \varepsilon_k(N'))}{f(bq_k \|q_k \alpha\| + \varepsilon_k(N))} \\ &\quad + \sum_{b=0}^{b_k-1} (V_k(bq_k \|q_k \alpha\| + \varepsilon_k(N')) - V_k(bq_k \|q_k \alpha\| + \varepsilon_k(N))) \\ &\quad + \log \frac{b_k q_k \|q_k \alpha\| + \varepsilon_k(N')}{b_k q_k \|q_k \alpha\| + \varepsilon_k(N)}. \end{aligned} \tag{37}$$

To estimate the second term in (37), note that by Lemma 6 we have

$$bq_k \|q_k \alpha\| + \varepsilon_k(N) \geq -(1 - \delta_T),$$

and that by the assumption $b_k \leq (1 - \delta_T)a_{k+1}$,

$$bq_k \|q_k \alpha\| + \varepsilon_k(N) \leq b_k q_k \|q_k \alpha\| \leq 1 - \delta_T.$$

Lemma 8(i) implies that $|V'_k(x)| \ll_T 1/a_{k+1}$ on the interval $[-(1 - \delta_T), 1 - \delta_T]$, and therefore

$$\left| \sum_{b=0}^{b_k-1} (V_k(bq_k \|q_k \alpha\| + \varepsilon_k(N')) - V_k(bq_k \|q_k \alpha\| + \varepsilon_k(N))) \right| \ll_T |\varepsilon_k(N') - \varepsilon_k(N)|.$$

Using (35),

$$\sum_{k=k_0}^{m-1} |\varepsilon_k(N') - \varepsilon_k(N)| \leq |b'_m - b_m| \cdot \|q_m \alpha\| \sum_{k=k_0}^{m-1} q_k \ll |b'_m - b_m| \cdot \|q_m \alpha\| q_{m-1} \leq \frac{|b'_m - b_m|}{a_{m+1}},$$

consequently from (36) and (37) we get

$$\begin{aligned} \log U_{N'} - \log U_N &= \log u_m(N') - \log u_m(N) \\ &\quad + \sum_{\substack{k=k_0, \\ b_k \geq 1}}^{m-1} \left(\sum_{b=1}^{b_k-1} \log \frac{f(bq_k \|q_k \alpha\| + \varepsilon_k(N'))}{f(bq_k \|q_k \alpha\| + \varepsilon_k(N))} + \log \frac{b_k q_k \|q_k \alpha\| + \varepsilon_k(N')}{b_k q_k \|q_k \alpha\| + \varepsilon_k(N)} \right) \\ &\quad + O_T \left(\frac{|b'_m - b_m|}{a_{m+1}} \right). \end{aligned} \tag{38}$$

Next, we show that the sum over $k_0 \leq k \leq m - 2$ in the previous formula is negligible. Let $k_0 \leq k \leq m - 2$. By assumption, $b_{k+1} \leq (1 - \delta_T)a_{k+2}$, and so $\varepsilon_k(N) \geq -(1 - \frac{1}{3}\delta_T)q_k \|q_k \alpha\|$ and $\varepsilon_k(N') \geq -(1 - \frac{1}{3}\delta_T)q_k \|q_k \alpha\|$

follow from [Lemma 6](#). In particular, $bq_k \|q_k \alpha\| + \varepsilon_k(N)$ and $bq_k \|q_k \alpha\| + \varepsilon_k(N')$ both lie in the interval $[(b - 1 + \frac{1}{3}\delta_T)q_k \|q_k \alpha\|, 1 - \delta_T]$ for all $1 \leq b \leq b_k - 1$. Since $|(\log f(x))'| \ll_T 1/((b - 1 + \frac{1}{3}\delta_T)q_k \|q_k \alpha\|)$ on this interval, we have

$$\begin{aligned} \sum_{b=1}^{b_k-1} \left| \log \frac{f(bq_k \|q_k \alpha\| + \varepsilon_k(N'))}{f(bq_k \|q_k \alpha\| + \varepsilon_k(N))} \right| &\ll_T \sum_{b=1}^{b_k-1} \frac{|\varepsilon_k(N') - \varepsilon_k(N)|}{(b - 1 + \frac{1}{3}\delta_T)q_k \|q_k \alpha\|} \\ &\ll_T a_{k+1} (\log a_{k+1}) |\varepsilon_k(N') - \varepsilon_k(N)| \\ &\ll_T a_{k+1} a_{k+2} q_k |b'_m - b_m| \cdot \|q_m \alpha\| \\ &\leq q_{k+2} |b'_m - b_m| \cdot \|q_m \alpha\|, \end{aligned}$$

where we used [\(35\)](#) and condition [\(6\)](#). Since $b_k q_k \|q_k \alpha\| + \varepsilon_k(N)$ and $b_k q_k \|q_k \alpha\| + \varepsilon_k(N')$ both lie in the interval $[\frac{1}{3}\delta_T q_k \|q_k \alpha\|, 2]$, and $|(\log x)'| \ll_T a_{k+1}$ on this interval, we similarly get

$$\left| \log \frac{b_k q_k \|q_k \alpha\| + \varepsilon_k(N')}{b_k q_k \|q_k \alpha\| + \varepsilon_k(N)} \right| \ll_T a_{k+1} |\varepsilon_k(N') - \varepsilon_k(N)| \ll q_{k+1} |b'_m - b_m| \cdot \|q_m \alpha\|.$$

From the previous two formulas and $\sum_{k=k_0}^{m-2} q_{k+2} \ll q_m$ we get

$$\sum_{\substack{k=k_0, \\ b_k \geq 1}}^{m-2} \left| \sum_{b=1}^{b_k-1} \log \frac{f(bq_k \|q_k \alpha\| + \varepsilon_k(N'))}{f(bq_k \|q_k \alpha\| + \varepsilon_k(N))} + \log \frac{b_k q_k \|q_k \alpha\| + \varepsilon_k(N')}{b_k q_k \|q_k \alpha\| + \varepsilon_k(N)} \right| \ll_T \frac{|b'_m - b_m|}{a_{m+1}},$$

and hence if $m > k_0$, [\(38\)](#) simplifies as

$$\begin{aligned} \log U_{N'} - \log U_N &= \log u_m(N') - \log u_m(N) \\ &+ \sum_{b=1}^{b_{m-1}-1} \log \frac{f(bq_{m-1} \|q_{m-1} \alpha\| + \varepsilon_{m-1}(N'))}{f(bq_{m-1} \|q_{m-1} \alpha\| + \varepsilon_{m-1}(N))} \\ &+ I_{\{b_{m-1} \geq 1\}} \log \frac{b_{m-1} q_{m-1} \|q_{m-1} \alpha\| + \varepsilon_{m-1}(N')}{b_{m-1} q_{m-1} \|q_{m-1} \alpha\| + \varepsilon_{m-1}(N)} + O_T \left(\frac{|b'_m - b_m|}{a_{m+1}} \right). \end{aligned} \tag{39}$$

If $m = k_0$, then [\(39\)](#) holds with the second and third terms on the right-hand side removed, and the claim for $m = k_0$ follows.

Let $m > k_0$. To proceed, we distinguish between two cases: Case 1 is $\varepsilon_{m-1}(N) < -(1 - \frac{1}{3}\delta_T)q_m \|q_m \alpha\|$, and Case 2 is $\varepsilon_{m-1}(N) \geq -(1 - \frac{1}{3}\delta_T)q_m \|q_m \alpha\|$. We will show that [\(34\)](#) holds in Case 1, and that [\(34\)](#) holds with equality in Case 2. Note that this will prove the proposition; indeed, [\(34\)](#) follows in either case, whereas by [Lemma 6](#) the additional assumption $b_m \leq (1 - \delta_T)a_{m+1}$ ensures that we are in Case 2.

Case 1: Assume that $\varepsilon_{m-1}(N) < -(1 - \frac{1}{3}\delta_T)q_m \|q_m \alpha\|$. By assumption, $b'_m \leq (1 - \delta_T)a_{m+1}$, and hence $\varepsilon_{m-1}(N') \geq -(1 - \frac{1}{3}\delta_T)q_m \|q_m \alpha\|$ follows from [Lemma 6](#). In particular, $\varepsilon_{m-1}(N) < \varepsilon_{m-1}(N')$, and hence

$$I_{\{b_{m-1} \geq 1\}} \log \frac{b_{m-1} q_{m-1} \|q_{m-1} \alpha\| + \varepsilon_{m-1}(N')}{b_{m-1} q_{m-1} \|q_{m-1} \alpha\| + \varepsilon_{m-1}(N)} \geq 0. \tag{40}$$

If $b_{m-1} = 0$ or 1 , then (34) follows from (39); therefore we may assume that $b_{m-1} \geq 2$. Since $(\log f(x))' = \pi \cot(\pi x)$, for any $1 \leq b \leq b_{m-1} - 1$ we have

$$\begin{aligned} \log \frac{f(bq_{m-1}\|q_{m-1}\alpha\| + \varepsilon_{m-1}(N'))}{f(bq_{m-1}\|q_{m-1}\alpha\| + \varepsilon_{m-1}(N))} &= \int_{bq_{m-1}\|q_{m-1}\alpha\| + \varepsilon_{m-1}(N)}^{bq_{m-1}\|q_{m-1}\alpha\| + \varepsilon_{m-1}(N')} \pi \cot(\pi x) \, dx \\ &\geq \pi \cot(\pi(bq_{m-1}\|q_{m-1}\alpha\| + \varepsilon_{m-1}(N'))) \cdot (\varepsilon_{m-1}(N') - \varepsilon_{m-1}(N)). \end{aligned}$$

Using $|\pi \cot(\pi x) - 1/x| \ll_T 1$ for all $|x| \leq 1 - \delta_T$, we get

$$\begin{aligned} \sum_{b=1}^{b_{m-1}-1} \pi \cot(\pi(bq_{m-1}\|q_{m-1}\alpha\| + \varepsilon_{m-1}(N'))) &= \sum_{b=1}^{b_{m-1}-1} \frac{1}{bq_{m-1}\|q_{m-1}\alpha\| + \varepsilon_{m-1}(N')} + O_T(a_m) \\ &= a_m \log(b_{m-1} + 1) + O_T(a_m). \end{aligned}$$

The previous two formulas give

$$\begin{aligned} \sum_{b=1}^{b_{m-1}-1} \log \frac{f(bq_{m-1}\|q_{m-1}\alpha\| + \varepsilon_{m-1}(N'))}{f(bq_{m-1}\|q_{m-1}\alpha\| + \varepsilon_{m-1}(N))} &\geq a_m(\log(b_{m-1} + 1))(\varepsilon_{m-1}(N') - \varepsilon_{m-1}(N)) + O_T(a_m|\varepsilon_{m-1}(N') - \varepsilon_{m-1}(N)|) \\ &= -(\log(b_{m-1} + 1))\frac{b'_m - b_m}{a_{m+1}} + O_T\left(\frac{|b'_m - b_m|}{a_{m+1}}\right), \end{aligned}$$

and therefore (39) and (40) imply the desired inequality (34). This concludes the proof of Case 1.

Case 2: Assume that $\varepsilon_{m-1}(N) \geq -(1 - \frac{1}{3}\delta_T)q_m\|q_m\alpha\|$. Repeating arguments from above, we now have

$$I_{\{b_{m-1} \geq 1\}} \log \frac{b_{m-1}q_{m-1}\|q_{m-1}\alpha\| + \varepsilon_{m-1}(N')}{b_{m-1}q_{m-1}\|q_{m-1}\alpha\| + \varepsilon_{m-1}(N)} = O_T\left(\frac{|b'_m - b_m|}{a_{m+1}}\right). \tag{41}$$

If $b_{m-1} = 0$ or 1 , then the sum in (39) is empty, and it follows that (34) holds with equality; thus we may again assume that $b_{m-1} \geq 2$. Since we are in Case 2, for any $1 \leq b \leq b_{m-1} - 1$ the points $bq_{m-1}\|q_{m-1}\alpha\| + \varepsilon_{m-1}(N)$ and $bq_{m-1}\|q_{m-1}\alpha\| + \varepsilon_{m-1}(N')$ lie in the interval

$$\left[(b - 1 + \frac{1}{3}\delta_T)q_{m-1}\|q_{m-1}\alpha\|, (b + 1)q_{m-1}\|q_{m-1}\alpha\| \right].$$

Note that here $(b + 1)q_{m-1}\|q_{m-1}\alpha\| \leq 1 - \delta_T$. We have $(\log f(x))' = \pi \cot(\pi x)$, and $|(\log f(x))''| = |\pi/\sin^2(\pi x)| \ll_T 1/(b^2q_{m-1}^2\|q_{m-1}\alpha\|^2)$ on the same interval. Applying a second-order Taylor formula, we thus get

$$\begin{aligned} \log \frac{f(bq_{m-1}\|q_{m-1}\alpha\| + \varepsilon_{m-1}(N'))}{f(bq_{m-1}\|q_{m-1}\alpha\| + \varepsilon_{m-1}(N))} &= \pi \cot(\pi(bq_{m-1}\|q_{m-1}\alpha\| + \varepsilon_{m-1}(N'))) (\varepsilon_{m-1}(N') - \varepsilon_{m-1}(N)) \\ &\quad + O_T\left(\frac{(\varepsilon_{m-1}(N') - \varepsilon_{m-1}(N))^2}{b^2q_{m-1}^2\|q_{m-1}\alpha\|^2}\right). \end{aligned}$$

The contribution of the error term is negligible:

$$\sum_{b=1}^{b_{m-1}-1} \frac{(\varepsilon_{m-1}(N') - \varepsilon_{m-1}(N))^2}{b^2 q_{m-1}^2 \|q_{m-1}\alpha\|^2} \ll a_m^2 (\varepsilon_{m-1}(N') - \varepsilon_{m-1}(N))^2 = a_m^2 q_{m-1}^2 (b'_m - b_m)^2 \|q_m \alpha\|^2 \leq \frac{|b'_m - b_m|}{a_{m+1}}.$$

Arguing as in Case 1, the previous two formulas yield

$$\sum_{b=1}^{b_{m-1}-1} \log \frac{f(bq_{m-1}\|q_{m-1}\alpha\| + \varepsilon_{m-1}(N'))}{f(bq_{m-1}\|q_{m-1}\alpha\| + \varepsilon_{m-1}(N))} = -(\log(b_{m-1} + 1)) \frac{b'_m - b_m}{a_{m+1}} + O_T\left(\frac{|b'_m - b_m|}{a_{m+1}}\right),$$

and therefore (39) and (41) imply that (34) holds with equality. This concludes the proof of Case 2. \square

4.2. Regularizing and optimizing projections. We introduced the concept of a projection in the definition on page 692. Starting with a nonnegative integer with Ostrowski expansion $N = \sum_{k=0}^{K-1} b_k q_k$, our strategy is to apply projections to N in two rounds. In the first, we project the coefficients with $b_k > (1 - \delta_T)a_{k+1}$ to

$$b_k^{**} := \begin{cases} 0 & \text{if } a_{k+1} = 2, \\ \lfloor (1 - \delta_T)a_{k+1} \rfloor & \text{if } a_{k+1} \neq 2 \end{cases} \tag{42}$$

in increasing order of the indices $k_0 \leq k \leq K - 1$. We call such a transformation a *regularizing projection*; its aim is to get away from the singularity of $\log|2 \sin(\pi x)|$ at $x = 1$. We note that the special value of b_k^{**} in the case $a_{k+1} = 2$ (0 instead of 1) serves a technical purpose, and will not cause difficulties in the end. After the first round of projections N is transformed into an integer whose k -th Ostrowski coefficient is $\leq (1 - \delta_T)a_{k+1}$ for all $k_0 \leq k \leq K - 1$. As we will see, the value of U_N does not decrease up to a small error during the first round.

In the second round we project each Ostrowski coefficient to $b_k^* = \lfloor \frac{5}{6}a_{k+1} \rfloor$, in increasing order of the indices $k_0 \leq k \leq K - 1$. We call such a transformation an *optimizing projection*. We now estimate the effect of a projection on the value of U_N based on its type.

Proposition 15. *Let $N = \sum_{k=0}^{K-1} b_k q_k$ be the Ostrowski expansion of a nonnegative integer, and let $k_0 \leq m \leq K - 1$.*

- (i) Regularizing projection: *Assume that $b_k \leq (1 - \delta_T)a_{k+1}$ for all $k_0 \leq k < m$, and that $b_m > (1 - \delta_T)a_{m+1}$. Then $\text{proj}_{m, b_m^{**}}(N) = N'$ satisfies*

$$\log U_{N'} - \log U_N \geq -O_T(1/a_{m+1}) - O_\alpha(1/q_m).$$

- (ii) Optimizing projection: *Assume that $b_k \leq (1 - \delta_T)a_{k+1}$ for all $k_0 \leq k \leq K - 1$, and that $b_k = b_k^*$ for all $k_0 \leq k < m$. Then $\text{proj}_{m, b_m^*}(N) = N'$ satisfies*

$$\begin{aligned} & \log U_{N'} - \log U_N \\ &= a_{m+1} \int_{b_m/a_{m+1}}^{b'_m/a_{m+1}} \log|2 \sin(\pi x)| dx + O_T\left(\frac{|b'_m - b_m|}{a_{m+1}} + I_{\{b_m \leq 0.01a_{m+1}\}} \log a_{m+1}\right) + O_\alpha(1/q_m), \end{aligned} \tag{43}$$

and also

$$\log U_{N'} - \log U_N \geq 0.2326 \frac{(b'_m - b_m)^2}{a_{m+1}} - O_T(1/a_{m+1}) - O_\alpha(1/q_m). \tag{44}$$

We first prove a lemma that will help in the case $a_{m+1} \ll 1$ and then give the proofs of parts (i) and (ii) of [Proposition 15](#).

Lemma 16. *Let $N = \sum_{k=0}^{K-1} b_k q_k$ be the Ostrowski expansion of a nonnegative integer. Let $k_0 \leq m \leq K - 1$. If $a_{m+1} \leq A$ with some constant $A \geq 1$, then*

$$\log u_m(N) \leq O_{T,A}(1) + O_\alpha(1/q_m). \tag{45}$$

If in addition $b_m \leq (1 - \delta_T)a_{m+1}$ and $b_{m+1} \leq (1 - \delta_T)a_{m+2}$, then (45) holds with $|\log u_m(N)|$ instead of $\log u_m(N)$ on the left-hand side.

Proof. Recall the definition on page [691](#). If $b_m = 0$, then $u_m(N) = 1$, and we are done. So assume $b_m \geq 1$.

First, we prove the upper bound. From the definition of $u_m(N)$ we immediately see that

$$u_m(N) \leq 2^A \exp\left(\sum_{b=0}^{b_m-1} V_m(bq_m \|q_m \alpha\| + \varepsilon_m(N))\right) 4\pi.$$

[Lemma 8\(i\)](#) implies that V_m is decreasing on $(-1, 1)$, and $|V'_m(x)| \ll_T 1/a_{m+1}$ on $[-(1 - \delta_T), 0]$. It is then readily seen that

$$\sum_{b=0}^{b_m-1} V_m(bq_m \|q_m \alpha\| + \varepsilon_m(N)) \leq b_m V_m(0) + O_T(1) = O_{T,A}(1) + O_\alpha(1/q_m),$$

and the claim $\log u_m(N) \leq O_{T,A}(1) + O_\alpha(1/q_m)$ follows.

Next, assume in addition, that $b_m \leq (1 - \delta_T)a_{m+1}$ and $b_{m+1} \leq (1 - \delta_T)a_{m+2}$. By [Lemma 6](#) we then have $\varepsilon_m(N) \geq -(1 - \frac{1}{3}\delta_T)q_m \|q_m \alpha\|$. Therefore the points $bq_m \|q_m \alpha\| + \varepsilon_m(N)$ for $1 \leq b \leq b_m - 1$ are bounded away from 0 and 1, and hence

$$\prod_{b=1}^{b_m-1} |2 \sin(\pi(bq_m \|q_m \alpha\| + \varepsilon_m(N)))| \gg_{T,A} 1.$$

Similarly, since the points $bq_m \|q_m \alpha\| + \varepsilon_m(N)$ for $0 \leq b \leq b_m - 1$ lie in the interval $[-(1 - \delta_T), 1 - \delta_T]$ and $|V'_m(x)| \ll_T 1/a_{m+1}$ on this interval by [Lemma 8\(i\)](#), we have

$$\left| \sum_{b=0}^{b_m-1} V_m(bq_m \|q_m \alpha\| + \varepsilon_m(N)) \right| = b_m |V_m(0)| + O_T(1) = O_{T,A}(1) + O_\alpha(1/q_m).$$

Finally, note that

$$2\pi(b_m q_m \|q_m \alpha\| + \varepsilon_m(N)) \geq 2\pi \cdot \frac{1}{3} \delta_T q_m \|q_m \alpha\| \gg_{T,A} 1.$$

The previous three estimates and the definition of $u_m(N)$ show that $\log u_m(N) \geq -O_{T,A}(1) - O_\alpha(1/q_m)$, as claimed. □

Proof of Proposition 15 (i). For the sake of readability, let $f(x) = |2 \sin(\pi x)|$ and $\varepsilon_m = \varepsilon_m(N) = \varepsilon_m(N')$. Since $b_m > b'_m$, and in particular $-(\log(b_{m-1} + 1))(b'_m - b_m)/(a_{m+1}) \geq 0$, Proposition 14 gives

$$\log U_{N'} - \log U_N \geq \log u_m(N') - \log u_m(N) - O_T\left(\frac{|b'_m - b_m|}{a_{m+1}}\right). \tag{46}$$

Let $A \geq 1$ be a large constant depending only on T (and δ_T), to be chosen. We will distinguish between three cases depending on the size of a_{m+1} .

Case 1: Assume that $a_{m+1} = 1$ or 2 . Then, by construction, $b'_m = b_m^{**} = 0$, and hence $u_m(N') = 1$. From (46) and Lemma 16 we thus get $\log U_{N'} - \log U_N \geq -O_T(1) - O_\alpha(1/q_m)$, and the claim follows.

Case 2: Assume that $3 \leq a_{m+1} \leq A$. Then, by construction, $b'_m = b_m^{**} \geq 2$. Recalling the definition on page 691, we have

$$\begin{aligned} &\log u_m(N') - \log u_m(N) \\ &= -\sum_{b=b'_m}^{b_m-1} \log f(bq_m \|q_m\alpha\| + \varepsilon_m) - \sum_{b=b'_m}^{b_m-1} V_m(bq_m \|q_m\alpha\| + \varepsilon_m) + \log \frac{b'_m q_m \|q_m\alpha\| + \varepsilon_m}{b_m q_m \|q_m\alpha\| + \varepsilon_m}. \end{aligned}$$

Since $-\log f(x)$ is bounded from below, the first term is $\geq -O_A(1)$. Similar to the proof of Lemma 16, it is easy to see that the second term is $\geq -O_{T,A}(1) - O_\alpha(1/q_m)$. Finally, the last term is

$$\log \frac{b'_m q_m \|q_m\alpha\| + \varepsilon_m}{b_m q_m \|q_m\alpha\| + \varepsilon_m} \geq \log \frac{b'_m - 1}{b_m + 1} \geq -O_T(1).$$

Hence $\log u_m(N') - \log u_m(N) \geq -O_{T,A}(1) - O_\alpha(1/q_m)$, and the claim follows from (46).

Case 3: Assume that $a_{m+1} > A$. By the definition on page 691, we again have

$$\begin{aligned} &\log u_m(N') - \log u_m(N) \\ &= -\sum_{b=b'_m}^{b_m-1} \log f(bq_m \|q_m\alpha\| + \varepsilon_m) - \sum_{b=b'_m}^{b_m-1} V_m(bq_m \|q_m\alpha\| + \varepsilon_m) + \log \frac{b'_m q_m \|q_m\alpha\| + \varepsilon_m}{b_m q_m \|q_m\alpha\| + \varepsilon_m}. \end{aligned}$$

From Lemma 8, in particular from the fact that $V_m(x)$ is decreasing, we get

$$\begin{aligned} -\sum_{b=b'_m}^{b_m-1} V_m(bq_m \|q_m\alpha\| + \varepsilon_m) &\geq -(b_m - b'_m)V_m(0) \\ &= -(b_m - b'_m) \frac{\log a_m}{a_{m+1}} - O_T\left(\frac{|b'_m - b_m|}{a_{m+1}}\right) - O_\alpha\left(\frac{|b'_m - b_m|}{q_{m+1}}\right) \\ &\geq -T(b_m - b'_m) - O_T\left(\frac{|b'_m - b_m|}{a_{m+1}}\right) - O_\alpha(1/q_m). \end{aligned}$$

Since $b_m q_m \|q_m\alpha\| + \varepsilon_k$ and $b'_m q_m \|q_m\alpha\| + \varepsilon_k$ are bounded away from zero, we also have

$$\log \frac{b'_m q_m \|q_m\alpha\| + \varepsilon_m}{b_m q_m \|q_m\alpha\| + \varepsilon_m} \ll \frac{|b_m - b'_m|}{a_{m+1}}.$$

By the previous two formulas, (46) simplifies to

$$\log U_{N'} - \log U_N \geq - \sum_{b=b'_m}^{b_m-1} \log f(bq_m \|q_m \alpha\| + \varepsilon_m) - T(b_m - b'_m) - O_T\left(\frac{|b'_m - b_m|}{a_{m+1}}\right) - O_\alpha(1/q_m). \quad (47)$$

For all $b'_m \leq b \leq b_m - 1$,

$$bq_m \|q_m \alpha\| + \varepsilon_k(N) \geq (\lfloor (1 - \delta_T)a_{m+1} \rfloor - 1)q_m \|q_m \alpha\| \geq 1 - 2\delta_T$$

provided that A is large enough in terms of T and δ_T . Choosing $\delta_T \leq 1/(4\pi e^{2T})$ ensures $\log f(x) \leq -2T$ on the interval $[1 - 2\delta_T, 1)$. Hence every term in the sum in (47) is $\leq -2T$, and we get

$$\log U_{N'} - \log U_N \geq T(b_m - b'_m) - O_T\left(\frac{|b'_m - b_m|}{a_{m+1}}\right) - O_\alpha(1/q_m).$$

Choosing A large enough in terms of T and δ_T , the second error term is negligible compared to $T(b_m - b'_m)$. Hence $\log U_{N'} - \log U_N \geq -O_\alpha(1/q_m)$, and the claim follows. \square

Proof of Proposition 15 (ii). Again, let $f(x) = |2 \sin(\pi x)|$ and $\varepsilon_m = \varepsilon_m(N) = \varepsilon_m(N')$. If $m = k_0$, then both sides of (43) and (44) are $O_\alpha(1)$, and we are done. We may thus assume that $m > k_0$. By the assumption $b_{m-1} = b_{m-1}^* = \lfloor \frac{5}{6}a_m \rfloor$ we have

$$-(\log(b_{m-1} + 1)) \frac{b'_m - b_m}{a_{m+1}} = -(b'_m - b_m) \frac{\log a_m}{a_{m+1}} + O\left(\frac{|b'_m - b_m|}{a_{m+1}}\right),$$

so Proposition 14 now gives

$$\log U_{N'} - \log U_N = \log u_m(N') - \log u_m(N) - (b'_m - b_m) \frac{\log a_m}{a_{m+1}} - O_T\left(\frac{|b'_m - b_m|}{a_{m+1}}\right). \quad (48)$$

Let $A \geq 1$ be a large constant depending only on T , to be chosen. We distinguish between four cases.

Case 1: Assume that $a_{m+1} \leq A$. By Lemma 16, both $\log u_m(N')$ and $\log u_m(N)$ are $O_{T,A}(1) + O_\alpha(1/q_m)$. Since $|b'_m - b_m|(\log a_m/a_{m+1}) \ll_{T,A} 1$, from (48) we get

$$\log U_{N'} - \log U_N = O_{T,A}(1) + O_\alpha(1/q_m),$$

and the claims (43) and (44) follow.

Case 2: Assume that $a_{m+1} > A$ and $1 \leq b_m \leq b'_m$. From the definition on page 691 we now get

$$\begin{aligned} & \log u_m(N') - \log u_m(N) \\ &= \sum_{b=b_m}^{b'_m-1} \log f(bq_m \|q_m \alpha\| + \varepsilon_m) + \sum_{b=b_m}^{b'_m-1} V_m(bq_m \|q_m \alpha\| + \varepsilon_m) + \log \frac{b'_m q_m \|q_m \alpha\| + \varepsilon_m}{b_m q_m \|q_m \alpha\| + \varepsilon_m}. \end{aligned}$$

The assumption $b_k \leq (1 - \delta_T)a_{k+1}$ for all $k_0 \leq k \leq K - 1$ and Lemma 6 imply that $\varepsilon_m \geq -(1 - \frac{1}{3}\delta_T)q_m \|q_m \alpha\|$.

We claim that the last term satisfies

$$\log \frac{b'_m q_m \|q_m \alpha\| + \varepsilon_m}{b_m q_m \|q_m \alpha\| + \varepsilon_m} \ll_T \frac{|b'_m - b_m|}{a_{m+1}} + I_{\{b_m \leq 0.01 a_{m+1}\}} \log a_{m+1}.$$

Indeed, if $b_m > 0.01 a_{m+1}$, then the points $b_m q_m \|q_m \alpha\| + \varepsilon_m$ and $b'_m q_m \|q_m \alpha\| + \varepsilon_m$ lie in an interval bounded away from zero, and $|(\log x)'| \ll_T 1$ on such an interval; the upper bound $|b'_m - b_m|/a_{m+1}$ follows. If $b_m \leq 0.01 a_{m+1}$, then

$$0 \leq \log \frac{b'_m q_m \|q_m \alpha\| + \varepsilon_m}{b_m q_m \|q_m \alpha\| + \varepsilon_m} \leq \log \frac{2}{(\frac{1}{3} \delta_T) q_m \|q_m \alpha\|} \ll_T \log a_{m+1},$$

and the claimed upper bound follows once again.

Observe also that for all $b_m \leq b \leq b'_m - 1$, the point $b q_m \|q_m \alpha\| + \varepsilon_m$ lies in $[0, \frac{5}{6}]$. Using [Lemma 8\(iii\)](#) we thus deduce

$$\sum_{b=b_m}^{b'_m-1} V_m(b q_m \|q_m \alpha\| + \varepsilon_m) = (b'_m - b_m) \frac{\log a_m}{a_{m+1}} + O_T \left(\frac{|b'_m - b_m|}{a_{m+1}} \right) + O_\alpha(1/q_m),$$

and hence

$$\begin{aligned} \log u_m(N') - \log u_m(N) &= \sum_{b=b_m}^{b'_m-1} \log f(b q_m \|q_m \alpha\| + \varepsilon_m) + (b'_m - b_m) \frac{\log a_m}{a_{m+1}} \\ &\quad + O_T \left(\frac{|b'_m - b_m|}{a_{m+1}} + I_{\{b_m \leq 0.01 a_{m+1}\}} \log a_{m+1} \right) + O_\alpha(1/q_m). \end{aligned}$$

With a remarkable cancellation of $(b'_m - b_m)(\log a_m/a_{m+1})$, [Equation \(48\)](#) thus simplifies to

$$\log U_{N'} - \log U_N = \sum_{b=b_m}^{b'_m-1} \log f(b q_m \|q_m \alpha\| + \varepsilon_m) + O_T \left(\frac{|b'_m - b_m|}{a_{m+1}} + I_{\{b_m \leq 0.01 a_{m+1}\}} \log a_{m+1} \right) + O_\alpha(1/q_m).$$

We now prove [\(43\)](#). Assume first that $b_m > 0.01 a_{m+1}$. Then for all $b_m \leq b \leq b'_m - 1$, the point $b q_m \|q_m \alpha\| + \varepsilon_m$ lies in an interval bounded away from 0 and 1. Using $q_m \|q_m \alpha\| = 1/a_{m+1} + O(1/a_{m+1}^2)$ and $|\varepsilon_m| \leq 1/a_{m+1}$ we deduce

$$|\log f(b q_m \|q_m \alpha\| + \varepsilon_m) - \log f(b/a_{m+1})| \ll 1/a_{m+1},$$

and hence

$$\sum_{b=b_m}^{b'_m-1} \log f(b q_m \|q_m \alpha\| + \varepsilon_m) = \sum_{b=b_m}^{b'_m-1} \log f(b/a_{m+1}) + O \left(\frac{|b'_m - b_m|}{a_{m+1}} \right).$$

Since $|\log f(x)| \ll |x - \frac{5}{6}|$ on our interval bounded away from 0 and 1, each term in the previous sum is $\ll |b_m - b'_m|/a_{m+1}$. Therefore, by interpreting the sum as a Riemann sum,

$$\sum_{b=b_m}^{b'_m-1} \log f(b/a_{m+1}) = a_{m+1} \int_{b_m/a_{m+1}}^{b'_m/a_{m+1}} \log f(x) dx + O \left(\frac{|b'_m - b_m|}{a_{m+1}} \right),$$

and (43) follows provided that $b_m > 0.01a_{m+1}$. If $b_m \leq 0.01a_{m+1}$, then for any $b_m \leq b \leq b'_m - 1$, the point $bq_m \|q_m \alpha\| + \varepsilon_m$ lies in $[(b - 1 + \frac{1}{3}\delta_T)q_m \|q_m \alpha\|, \frac{5}{6}]$. Since $|(\log f(x))'| = |\pi \cot(\pi x)| \ll_T a_{m+1}/b$ on this interval, we now have

$$\sum_{b=b_m}^{b'_m-1} |\log f(bq_m \|q_m \alpha\| + \varepsilon_m) - \log f(b/a_{m+1})| \ll_T \sum_{b=b_m}^{b'_m-1} \frac{1}{b} \ll \log a_{m+1}.$$

Note that $|\log f(b/a_{m+1})| \ll \log a_{m+1}$, so by interpreting the sum as a Riemann sum, we now have

$$\sum_{b=b_m}^{b'_m-1} \log f(b/a_{m+1}) = a_{m+1} \int_{b_m/a_{m+1}}^{b'_m/a_{m+1}} \log f(x) dx + O_T(\log a_{m+1}),$$

and (43) follows in the case $b_m \leq 0.01a_{m+1}$ as well.

Next, we deduce (44) from (43). Choosing A large enough in terms of T , the error term in (43) is negligible compared to the main term (in both cases $b_m \leq 0.01a_{m+1}$ and $b_m > 0.01a_{m+1}$). Elementary calculations show that

$$\min_{y \in [0, 5/6)} \frac{1}{(5/6 - y)^2} \int_y^{5/6} \log f(x) dx = \frac{1}{(5/6)^2} \int_0^{5/6} \log f(x) dx = 0.23260748 \dots$$

Indeed, the left-hand side is an increasing function of y on $[0, \frac{5}{6})$; to see that its derivative is nonnegative, it is enough to check that

$$\frac{1}{5/6 - y} \int_y^{5/6} \log f(x) dx \geq \frac{1}{2} \log f(y),$$

and this follows from the concavity of $\log f(x)$. Therefore, up to a negligible $O(1/a_{m+1})$ error in the numerical constants,

$$a_{m+1} \int_{b_m/a_{m+1}}^{b'_m/a_{m+1}} \log f(x) dx \geq a_{m+1} \cdot 0.2326 (b_m/a_{m+1} - \frac{5}{6})^2 \geq 0.2326 \frac{(b'_m - b_m)^2}{a_{m+1}}.$$

This finishes the proof of (43) and (44) in Case 2.

Case 3: Assume that $a_{m+1} > A$ and $b_m = 0$. Then $\log u_m(N) = 0$, and

$$\begin{aligned} & \log u_m(N') - \log u_m(N) \\ &= \sum_{b=1}^{b'_m-1} \log f(bq_m \|q_m \alpha\| + \varepsilon_m) + \sum_{b=0}^{b'_m-1} V_m(bq_m \|q_m \alpha\| + \varepsilon_m) + \log(b'_m q_m \|q_m \alpha\| + \varepsilon_m). \end{aligned}$$

Following the steps of Case 2 (observe that in the first sum the summation now starts at $b = 1$ instead of $b = b_m = 0$), we get

$$\log U_{N'} - \log U_N = a_{m+1} \int_{1/a_{m+1}}^{b'_m/a_{m+1}} \log f(x) dx + O_T(\log a_{m+1}) + O_\alpha(1/q_m).$$

The error of replacing the lower limit of integration by zero is negligible:

$$a_{m+1} \int_0^{1/a_{m+1}} \log f(x) \, dx \ll \log a_{m+1},$$

and (43) follows. We deduce (44) from (43) as in Case 2.

Case 4: Assume that $a_{m+1} > A$ and $b'_m \leq b_m \leq (1 - \delta_T)a_{m+1}$. Working on the interval $[\frac{5}{6}, 1 - \delta_T]$ instead of $[0, \frac{5}{6}]$, the proof of (43) is entirely analogous to that in Case 2. Deducing (44) from (43) is even simpler. Indeed, note that by concavity, $\log f(x) \leq -\pi\sqrt{3}(x - \frac{5}{6})$, the right-hand side being a tangent line. Hence up to a negligible $O(1/a_{m+1})$ error in the numerical constants,

$$a_{m+1} \int_{b'_m/a_{m+1}}^{b_m/a_{m+1}} \log f(x) \, dx \geq a_{m+1} \int_{b'_m/a_{m+1}}^{b_m/a_{m+1}} \pi\sqrt{3}(x - \frac{5}{6}) \, dx \geq \frac{\pi\sqrt{3}}{2} \cdot \frac{(b'_m - b_m)^2}{a_{m+1}}.$$

The lower bound (44) thus follows, in fact with the better numerical constant $\frac{\pi\sqrt{3}}{2} \approx 2.72$. □

4.3. Completing the proof.

Proof of Theorem 1. Let $N = \sum_{k=0}^{K-1} b_k q_k$ be the Ostrowski expansion of a nonnegative integer, and let $N^* = \sum_{k=0}^{K-1} b_k^* q_k$ with $b_k^* = \lfloor \frac{5}{6} a_{k+1} \rfloor$. Noting that $F_k(N^*) = 0$ for all k , from Proposition 13 we get

$$\log P_N(\alpha) - \log P_{N^*}(\alpha) = \log U_N - \log U_{N^*} - \sum_{k=k_0}^{K-1} F_k(N) + O_T\left(\sum_{k=1}^K \frac{1}{a_k}\right) + O_\alpha(1),$$

where $F_k(N) \geq 0$ for all k , and $F_k(N) = 0$ for all k such that $b_k \leq (1 - \delta_T)a_{k+1}$.

Let us now successively apply projections to N in two rounds, as described in Section 4.2: the first round consists of regularizing projections in increasing order of the indices $k_0 \leq k \leq K - 1$, and the second round consists of optimizing projections in increasing order of the indices. This way N is transformed into the integer $\sum_{k=0}^{k_0-1} b_k q_k + \sum_{k=k_0}^{K-1} b_k^* q_k$. Since U_N does not depend on the first k_0 Ostrowski coefficients, Proposition 15 allows us to write $\log U_{N^*} - \log U_N = \sum_{k=k_0}^{K-1} (d_k^{\text{reg}}(N) + d_k^{\text{opt}}(N))$, and hence

$$\log P_N(\alpha) - \log P_{N^*}(\alpha) = - \sum_{k=k_0}^{K-1} (d_k^{\text{reg}}(N) + d_k^{\text{opt}}(N) + F_k(N)) + O_T\left(\sum_{k=1}^K \frac{1}{a_k}\right) + O_\alpha(1).$$

Here $d_k^{\text{reg}}(N)$ resp. $d_k^{\text{opt}}(N)$ describe the effect of the regularizing resp. optimizing projection with respect to the index k , and by Proposition 15, they satisfy the following for all $k_0 \leq k \leq K - 1$:

- (i) If $b_k \leq (1 - \delta_T)a_{k+1}$, then $d_k^{\text{reg}}(N) = 0$.
- (ii) If $b_k > (1 - \delta_T)a_{k+1}$, then $d_k^{\text{reg}}(N) \geq -O_T(1/a_{k+1}) - O_\alpha(1/q_k)$.
- (iii) If $b_k \leq (1 - \delta_T)a_{k+1}$, then

$$d_k^{\text{opt}} = a_{k+1} \int_{b_k/a_{k+1}}^{b_k^*/a_{k+1}} \log |2 \sin(\pi x)| \, dx + O_T\left(\frac{|b_k - b_k^*|}{a_{k+1}} + I_{\{b_k \leq 0.01 a_{k+1}\}} \log a_{k+1}\right) + O_\alpha(1/q_k).$$

$$(iv) \ d_k^{\text{opt}}(N) \geq 0.2326 \frac{(b_k - b_k^*)^2}{a_{k+1}} - O_T(1/a_{k+1}) - O_\alpha(1/q_k).$$

(v) If $b_k = b_k^*$, then $d_k^{\text{opt}}(N) = 0$.

Note that if $b_k > (1 - \delta_T)a_{k+1}$, then b_k is first projected to b_k^{**} as defined in (42), and then to b_k^* . Proposition 15(ii) thus yields property (iv) with b_k^{**} in place of b_k . Choosing δ_T small enough, property (iv) also holds as stated with an arbitrarily smaller numerical constant. Observe also that the special value of b_k^{**} in the case $a_{k+1} = 2$ does not cause any problem.

It follows that we can introduce small error terms $\xi_k(N) = O_T(1/a_{k+1}) + O_\alpha(1/q_k)$ such that $d_k(N) := d_k^{\text{reg}}(N) + d_k^{\text{opt}}(N) + F_k(N) + \xi_k(N)$ satisfies $d_k(N) \geq 0.2326(b_k - b_k^*)^2/a_{k+1}$ for all $k_0 \leq k \leq K - 1$ with equality if $b_k = b_k^*$, and also

$$d_k(N) = a_{k+1} \int_{b_k/a_{k+1}}^{b_k^*/a_{k+1}} \log|2 \sin(\pi x)| \, dx + O_T\left(\frac{|b_k - b_k^*|}{a_{k+1}} + I_{\{b_k \leq 0.01a_{k+1}\}} \log a_{k+1}\right)$$

for all $k_0 \leq k \leq K - 1$ such that $b_k \leq (1 - \delta_T)a_{k+1}$. Since the contribution of the error terms $\xi_k(N)$ is negligible, we also have

$$\log P_N(\alpha) - \log P_{N^*}(\alpha) = - \sum_{k=k_0}^{K-1} d_k(N) + O\left(\sum_{k=1}^K \frac{1}{a_k}\right) + O_\alpha(1).$$

Finally, introduce $d_k(N)$, $0 \leq k < k_0$, in any way which satisfies the desired properties, and observe that $\sum_{k=0}^{k_0-1} d_k(N) = O_\alpha(1)$. This concludes the proof of Theorem 1. □

5. Proof of Theorem 2

Note that (11) follows directly from Theorem 1, in particular from $d_k(N) \geq 0$; alternatively, it also follows from taking the limit in (10) as $c \rightarrow \infty$. It will thus be enough to prove (10).

The main idea of the proof is that if we choose an integer N randomly from the interval $0 \leq N < q_K$, then its Ostrowski coefficients b_k , $0 \leq k \leq K - 1$, are almost independent random variables, close to being uniformly distributed on $\{0, 1, \dots, a_{k+1}\}$. As a Gaussian tail estimate will show, the coefficients $|b_k - b_k^*| \gg \sqrt{a_{k+1} \log a_{k+1}}$ have negligible contribution. By Theorem 1, and in particular (9), we thus have

$$\begin{aligned} \sum_{N=0}^{q_K-1} P_N(\alpha)^c &\approx \sum_{b_0=0}^{a_1} \sum_{b_1=0}^{a_2} \cdots \sum_{b_{K-1}=0}^{a_K} P_{N^*}(\alpha)^c \exp\left(-\sum_{k=0}^{K-1} \frac{\pi \sqrt{3}c}{2} \cdot \frac{(b_k - b_k^*)^2}{a_{k+1}}\right) \\ &\approx P_{N^*}(\alpha)^c \prod_{k=0}^{K-1} \sum_{n \in \mathbb{Z}} \exp\left(-\frac{\pi \sqrt{3}cn^2}{2a_{k+1}}\right) \\ &\approx P_{N^*}(\alpha)^c \prod_{k=0}^{K-1} \sqrt{\frac{2a_{k+1}}{\sqrt{3}c}}, \end{aligned}$$

which explains the main term in (10). We now give the formal proof.

Proof of Theorem 2. Let $c \geq 0.01$, and consider the intervals

$$J_k = [0, 0.99a_{k+1}] \cap [b_k^* - r_k, b_k^* + r_k] \cap \mathbb{Z},$$

where

$$r_k = 10\sqrt{\frac{a_{k+1}}{c} \log\left(\frac{a_{k+1}}{c} + 2\right)}.$$

First, we prove the lower bound in (10). Note that for any $\underline{b} = (b_0, b_1, \dots, b_{K-1}) \in J_0 \times J_1 \times \dots \times J_{K-1}$, the expression $N_{\underline{b}} = \sum_{k=0}^{K-1} b_k q_k$ is the Ostrowski expansion of an integer $0 \leq N_{\underline{b}} < q_K$; moreover, we obtain each integer at most once. We wish to apply Theorem 1 to $N_{\underline{b}}$, and simply discard all other integers in $[0, q_K)$ not of this form. Since for all $b_k \in J_k$ we have

$$\frac{|b_k - b_k^*|}{a_{k+1}} + \frac{|b_k - b_k^*|^3}{a_{k+1}^2} \ll E_{k,c} := \frac{\log^{1/2}(a_{k+1}/c + 2)}{c^{1/2}a_{k+1}^{1/2}} + \frac{\log^{3/2}(a_{k+1}/c + 2)}{c^{3/2}a_{k+1}^{1/2}},$$

Theorem 1 and (9) yield

$$P_{N_{\underline{b}}}(\alpha) = P_{N^*}(\alpha) \exp\left(-\sum_{k=0}^{K-1} \frac{\pi\sqrt{3}}{2} \cdot \frac{(b_k - b_k^*)^2}{a_{k+1}}\right) \exp\left(O_T\left(\sum_{k=1}^K \left(E_{k,c} + \frac{1}{a_k}\right)\right) + O_\alpha(1)\right).$$

Consequently,

$$\begin{aligned} \log\left(\sum_{N=0}^{q_K-1} P_N(\alpha)^c\right)^{1/c} &\geq \log\left(\sum_{\underline{b} \in J_0 \times J_1 \times \dots \times J_{K-1}} P_{N_{\underline{b}}}(\alpha)^c\right)^{1/c} \\ &\geq \log P_{N^*}(\alpha) + \frac{1}{c} \log \sum_{\underline{b} \in J_0 \times J_1 \times \dots \times J_{K-1}} \exp\left(-\sum_{k=0}^{K-1} \frac{\pi\sqrt{3}c}{2} \cdot \frac{(b_k - b_k^*)^2}{a_{k+1}}\right) \\ &\quad - O_T\left(\sum_{k=1}^K \left(E_{k,c} + \frac{1}{a_k}\right)\right) - O_\alpha(1). \end{aligned}$$

The sum over \underline{b} factors:

$$\sum_{\underline{b} \in J_0 \times J_1 \times \dots \times J_{K-1}} \exp\left(-\sum_{k=0}^{K-1} \frac{\pi\sqrt{3}c}{2} \cdot \frac{(b_k - b_k^*)^2}{a_{k+1}}\right) = \prod_{k=0}^{K-1} \sum_{b_k \in J_k} \exp\left(-\frac{\pi\sqrt{3}c}{2} \cdot \frac{(b_k - b_k^*)^2}{a_{k+1}}\right).$$

Now let $A > 0$ be a large universal constant, to be chosen. We establish a lower bound in each of the cases $a_{k+1}/c > A$ and $a_{k+1}/c \leq A$ separately. First, assume that $a_{k+1}/c > A$. We then have

$$r_k = 10\sqrt{\frac{a_{k+1}}{c} \log\left(\frac{a_{k+1}}{c} + 2\right)} \leq \frac{a_{k+1}}{10000c} \leq \frac{a_{k+1}}{100},$$

provided that $A > 0$ is large enough. In particular, $[b_k^* - r_k, b_k^* + r_k] \subset [0, 0.99a_{k+1}]$. It is now easy to see that

$$\begin{aligned} \sum_{b_k \in J_k} \exp\left(-\frac{\pi\sqrt{3}c}{2} \cdot \frac{(b_k - b_k^*)^2}{a_{k+1}}\right) &\geq \sum_{-r_k \leq n \leq r_k} \exp\left(\frac{-\pi\sqrt{3}cn^2}{2a_{k+1}}\right) \\ &= \int_{-r_k}^{r_k} \exp\left(\frac{-\pi\sqrt{3}cx^2}{2a_{k+1}}\right) dx + O(1) \\ &= \sqrt{\frac{2a_{k+1}}{\sqrt{3}c}} + O(1), \end{aligned}$$

and so

$$\frac{1}{c} \log \sum_{b_k \in J_k} \exp\left(-\frac{\pi\sqrt{3}c}{2} \cdot \frac{(b_k - b_k^*)^2}{a_{k+1}}\right) \geq \frac{1}{2c} \log \frac{2a_{k+1}}{\sqrt{3}c} - O\left(\frac{1}{a_{k+1}}\right)$$

in the case $a_{k+1}/c > A$. If $a_{k+1}/c \leq A$, then by noting that $b_k^* \in J_k$, the left-hand side of the previous formula is nonnegative, and thus the previous formula remains true. Altogether we obtain the lower bound

$$\log\left(\sum_{N=0}^{q_K-1} P_N(\alpha)^c\right)^{1/c} \geq \log P_{N^*}(\alpha) + \frac{1}{2c} \sum_{k=1}^K \log \frac{2a_k}{\sqrt{3}c} - O_T\left(\sum_{k=1}^K \left(E_{k,c} + \frac{1}{a_k}\right)\right) - O_\alpha(1).$$

Next, we prove the upper bound in (10). Applying [Theorem 1](#) to all $0 \leq N < q_K$, we get

$$\log\left(\sum_{N=0}^{q_K-1} P_N(\alpha)^c\right)^{1/c} = \log P_{N^*} + \frac{1}{c} \log \sum_{N=0}^{q_K-1} \exp\left(-c \sum_{k=0}^{K-1} d_k(N)\right) + O_T\left(\sum_{k=1}^K \frac{1}{a_k}\right) + O_\alpha(1).$$

For the sake of readability, note that $0.2326 > \frac{1}{5}$. Letting

$$g_k(x) = \begin{cases} \frac{\pi\sqrt{3}}{2} \cdot \frac{(x - b_k^*)^2}{a_{k+1}} & \text{if } x \in J_k, \\ \frac{(x - b_k^*)^2}{5a_{k+1}} & \text{if } x \notin J_k, \end{cases}$$

we have $d_k(N) \geq g_k(b_k) - O_T(E_{k,c})$. Hence, by extending the range of summation,

$$\log\left(\sum_{N=0}^{q_K-1} P_N(\alpha)^c\right)^{1/c} \leq \log P_{N^*} + \frac{1}{c} \log \sum_{\underline{b} \in \mathbb{Z}^K} \exp\left(-c \sum_{k=0}^{K-1} g_k(b_k)\right) + O_T\left(\sum_{k=1}^K \left(E_{k,c} + \frac{1}{a_k}\right)\right) + O_\alpha(1).$$

The sum over \underline{b} factors again:

$$\frac{1}{c} \log \sum_{\underline{b} \in \mathbb{Z}^K} \exp\left(-c \sum_{k=0}^{K-1} g_k(b_k)\right) = \frac{1}{c} \sum_{k=0}^{K-1} \log \sum_{b_k \in \mathbb{Z}} \exp\left(-cg_k(b_k)\right).$$

Now let $B > 0$ be a large universal constant, to be chosen. Assume first that $a_{k+1}/c > B$. Then, as before, $[b_k^* - r_k, b_k^* + r_k] \subset [0, 0.99a_{k+1}]$ provided that $B > 0$ is large enough. Therefore

$$\begin{aligned} \sum_{b_k \in \mathbb{Z}} \exp(-cg_k(b_k)) &\leq \sum_{|b_k - b_k^*| \leq r_k} \exp\left(-\frac{\pi\sqrt{3}c}{2} \cdot \frac{(b_k - b_k^*)^2}{a_{k+1}}\right) + \sum_{|b_k - b_k^*| > r_k} \exp\left(-c \frac{(b_k - b_k^*)^2}{5a_{k+1}}\right) \\ &\leq \int_{-\infty}^{\infty} \exp\left(\frac{-\pi\sqrt{3}cx^2}{2a_{k+1}}\right) dx + \int_{(-\infty, -r_k) \cup (r_k, \infty)} \exp\left(\frac{-cx^2}{5a_{k+1}}\right) dx + O(1) \\ &= \sqrt{\frac{2a_{k+1}}{\sqrt{3}c}} + O(1), \end{aligned}$$

and consequently

$$\frac{1}{c} \log \sum_{b_k \in \mathbb{Z}} \exp(-cg_k(b_k)) \leq \frac{1}{2c} \log \frac{2a_{k+1}}{\sqrt{3}c} + O\left(\frac{1}{a_{k+1}}\right).$$

If $a_{k+1}/c \leq B$, then simply using $g_k(b_k) \geq (b_k - b_k^*)^2/(5a_{k+1})$ we similarly deduce that the left-hand side of the previous formula is $\leq O(1/c)$; consequently, the previous formula remains true. Altogether we obtain the upper bound

$$\log\left(\sum_{N=0}^{q_K-1} P_N(\alpha)^c\right)^{1/c} \leq \log P_{N^*}(\alpha) + \frac{1}{2c} \sum_{k=1}^K \log \frac{2a_k}{\sqrt{3}c} + O_T\left(\sum_{k=1}^K \left(E_{k,c} + \frac{1}{a_k}\right)\right) + O_\alpha(1).$$

This concludes the proof of (10). □

6. Proof of Theorem 3

In this section we estimate $P_{N^*}(\alpha)$. By Proposition 13 it is enough to consider U_{N^*} ; in particular, we will need to estimate

$$\begin{aligned} \log u_k(N^*) &= \sum_{b=1}^{b_k^*-1} \log |2 \sin(\pi(bq_k \|q_k \alpha\| + \varepsilon_k(N^*)))| + \sum_{b=0}^{b_k^*-1} V_k(bq_k \|q_k \alpha\| + \varepsilon_k(N^*)) \\ &\quad + \log(2\pi(b_k^*q_k \|q_k \alpha\| + \varepsilon_k(N^*))). \end{aligned}$$

The first sum can be handled with a straightforward application of a second-order Euler–Maclaurin formula. Since it provides an elementary explanation for the appearance of the constant $\text{Vol}(4_1)$, we include a detailed proof in Lemma 17 below. An estimate for the second sum follows from Lemma 8(iii); Theorem 3 will then be an immediate corollary.

We now give a formal proof. We will need the value of the integrals

$$\int_1^\infty \frac{B_2(\{x\})}{(x - 5/6)^2} dx = \frac{1}{3} - \log \frac{\Gamma(\frac{1}{6})}{2^{5/6} 3^{1/3} \pi^{1/2}} \tag{49}$$

and

$$\int_1^\infty \frac{B_2(\{x\})}{x^2} dx = -\frac{11}{12} + \log(2^{1/2} \pi^{1/2}), \tag{50}$$

where $B_2(x) = \frac{1}{2}x^2 - \frac{1}{2}x + \frac{1}{12}$ is the second Bernoulli polynomial, and Γ is the gamma function. Indeed, by Stirling's formula for the gamma function,

$$\sum_{k=1}^n \log(k - \frac{5}{6}) = \log \frac{\Gamma(n + \frac{1}{6})}{\Gamma(\frac{1}{6})} = (n - \frac{5}{6}) \log(n - \frac{5}{6}) - (n - \frac{5}{6}) + \log \sqrt{2\pi(n - \frac{5}{6})} - \log \Gamma(\frac{1}{6}) + o(1).$$

On the other hand, applying a second-order Euler–Maclaurin formula we get

$$\sum_{k=1}^n \log(k - \frac{5}{6}) = \int_1^n \log(x - \frac{5}{6}) dx + \frac{1}{2}(\log(n - \frac{5}{6}) + \log(\frac{1}{6})) + \frac{1}{12}(1/(n - \frac{5}{6}) - 6) + \int_1^n \frac{B_2(\{x\})}{(x - \frac{5}{6})^2} dx,$$

and by comparing the asymptotics as $n \rightarrow \infty$ in the previous formulas, (49) follows; the proof of (50) is analogous.

Lemma 17. *Let $N^* = \sum_{k=0}^{K-1} b_k^* q_k$ with $b_k^* = \lfloor \frac{5}{6} a_{k+1} \rfloor$. For any $0 \leq k \leq K - 2$,*

$$\begin{aligned} \sum_{b=1}^{b_k^*-1} \log |2 \sin(\pi(bq_k \|q_k \alpha\| + \varepsilon_k(N^*)))| \\ = \frac{\text{Vol}(4_1)}{4\pi q_k \|q_k \alpha\|} - \frac{1}{3} \log a_{k+1} - \log \frac{\Gamma(\frac{1}{6})}{(2\pi)^{5/6}} + O\left(\frac{1}{a_{k+1}} + \frac{1 + \log a_{k+1}}{a_{k+2}}\right), \end{aligned}$$

whereas for $k = K - 1$,

$$\sum_{b=1}^{b_k^*-1} \log |2 \sin(\pi(bq_k \|q_k \alpha\| + \varepsilon_k(N^*)))| = \frac{\text{Vol}(4_1)}{4\pi q_{K-1} \|q_{K-1} \alpha\|} + \frac{1}{2} \log a_K + O\left(\frac{1}{a_K}\right).$$

Proof. For the sake of readability, let $f(x) = |2 \sin(\pi x)|$ and $\varepsilon_k = \varepsilon_k(N^*)$. By the definition (12) of ε_k and the construction of b_k^* , for all $0 \leq k \leq K - 2$, we have

$$\varepsilon_k = q_k \sum_{\ell=k+1}^{K-1} (-1)^{k+\ell} \frac{5}{6} a_{\ell+1} \|q_\ell \alpha\| + O\left(q_k \sum_{\ell=k+1}^{K-1} \|q_\ell \alpha\|\right) = -\frac{5}{6} q_k \|q_k \alpha\| + O(q_k \|q_{k+1} \alpha\|),$$

and, in particular,

$$\frac{\varepsilon_k}{q_k \|q_k \alpha\|} = -\frac{5}{6} + O\left(\frac{1}{a_{k+2}}\right), \tag{51}$$

whereas $\varepsilon_{K-1} = 0$. Since $b_{k+1}^* \leq \frac{5}{6} a_{k+2}$, Lemma 6 also gives $q_k \|q_k \alpha\| + \varepsilon_k \geq 1/(18a_{k+1})$.

Consider the following function F , along with its first and second derivatives:

$$\begin{aligned} F(x) &= \log f(xq_k \|q_k \alpha\| + \varepsilon_k), \\ F'(x) &= \pi \cot(\pi(xq_k \|q_k \alpha\| + \varepsilon_k))q_k \|q_k \alpha\|, \\ F''(x) &= -\frac{\pi^2 q_k^2 \|q_k \alpha\|^2}{\sin^2(\pi(xq_k \|q_k \alpha\| + \varepsilon_k))}. \end{aligned}$$

Applying a second-order Euler–Maclaurin formula, we get

$$\sum_{b=1}^{b_k^*-1} F(b) = \int_1^{b_k^*-1} F(x) dx + \frac{F(b_k^* - 1) + F(1)}{2} + \frac{F'(b_k^* - 1) - F'(1)}{12} - \int_1^{b_k^*-1} F''(x) B_2(\{x\}) dx. \quad (52)$$

First, we estimate the main term

$$\int_1^{b_k^*-1} F(x) dx = \frac{1}{q_k \|q_k \alpha\|} \int_{q_k \|q_k \alpha\| + \varepsilon_k}^{(b_k^*-1)q_k \|q_k \alpha\| + \varepsilon_k} \log f(y) dy.$$

Here by construction $(b_k^* - 1)q_k \|q_k \alpha\| + \varepsilon_k = \frac{5}{6} + O(1/a_{k+1})$. Since $\log f(\frac{5}{6}) = 0$, the error of replacing the upper limit of integration by $\frac{5}{6}$ is negligible:

$$\frac{1}{q_k \|q_k \alpha\|} \left| \int_{(b_k^*-1)q_k \|q_k \alpha\| + \varepsilon_k}^{\frac{5}{6}} \log f(y) dy \right| \ll \frac{1}{a_{k+1}}.$$

The effect of replacing the lower limit of integration by 0 is

$$\begin{aligned} \frac{1}{q_k \|q_k \alpha\|} \int_0^{q_k \|q_k \alpha\| + \varepsilon_k} \log f(y) dy &= \frac{1}{q_k \|q_k \alpha\|} \int_0^{q_k \|q_k \alpha\| + \varepsilon_k} \log(2\pi y) dy + O\left(\frac{1}{a_{k+1}^2}\right) \\ &= \left(1 + \frac{\varepsilon_k}{q_k \|q_k \alpha\|}\right) (\log(2\pi(q_k \|q_k \alpha\| + \varepsilon_k)) - 1) + O\left(\frac{1}{a_{k+1}^2}\right). \end{aligned}$$

From the previous three formulas and (51) it follows that the main term in (52) is, for all $0 \leq k \leq K - 2$,

$$\int_1^{b_k^*-1} F(x) dx = \frac{1}{q_k \|q_k \alpha\|} \int_0^{\frac{5}{6}} \log f(y) dy + \frac{1}{6} + \frac{1}{6} \log \frac{3a_{k+1}}{\pi} + O\left(\frac{1}{a_{k+1}} + \frac{1 + \log a_{k+1}}{a_{k+2}}\right), \quad (53)$$

whereas for $k = K - 1$,

$$\int_1^{b_{K-1}^*-1} F(x) dx = \frac{1}{q_{K-1} \|q_{K-1} \alpha\|} \int_0^{\frac{5}{6}} \log f(y) dy + 1 + \log \frac{a_K}{2\pi} + O\left(\frac{1}{a_K}\right). \quad (54)$$

Next, consider the second and third terms in (52). It is easy to see that $F(b_k^* - 1) \ll 1/a_{k+1}$ and $F'(b_k^* - 1) \ll 1/a_{k+1}$. Further,

$$F(1) = \log f(q_k \|q_k \alpha\| + \varepsilon_k) = \log(2\pi(q_k \|q_k \alpha\| + \varepsilon_k)) + O\left(\frac{1}{a_{k+1}^2}\right),$$

and using $\pi \cot(\pi y) = 1/y + O(|y|)$ on $(0, \frac{5}{6}]$,

$$F'(1) = \pi \cot(\pi(q_k \|q_k \alpha\| + \varepsilon_k)) q_k \|q_k \alpha\| = \frac{q_k \|q_k \alpha\|}{q_k \|q_k \alpha\| + \varepsilon_k} + O\left(\frac{1}{a_{k+1}^2}\right).$$

Hence, by (51), for $0 \leq k \leq K - 2$ we have

$$\frac{F(b_k^* - 1) + F(1)}{2} + \frac{F'(b_k^* - 1) - F'(1)}{12} = -\frac{1}{2} - \frac{1}{2} \log \frac{3a_{k+1}}{\pi} + O\left(\frac{1}{a_{k+1}} + \frac{1}{a_{k+2}}\right), \quad (55)$$

whereas for $k = K - 1$,

$$\frac{F(b_{K-1}^* - 1) + F(1)}{2} + \frac{F'(b_{K-1}^* - 1) - F'(1)}{12} = -\frac{1}{12} - \frac{1}{2} \log \frac{a_K}{2\pi} + O\left(\frac{1}{a_K}\right). \tag{56}$$

Finally, consider the last term in (52). Using $\pi^2/\sin^2(\pi y) = 1/y^2 + O(1)$ on $(0, \frac{5}{6}]$,

$$-\int_1^{b_k^*-1} F''(x)B_2(\{x\}) dx = \int_1^{b_k^*-1} \frac{B_2(\{x\})}{(x + \varepsilon_k/(q_k\|q_k\alpha\|))^2} dx + O\left(\frac{1}{a_{k+1}}\right).$$

Therefore, by (51) and the improper integrals (49) and (50), for all $0 \leq k \leq K - 2$ we have

$$-\int_1^{b_k^*-1} F''(x)B_2(\{x\}) dx = \frac{1}{3} - \log \frac{\Gamma(\frac{1}{6})}{2^{5/6}3^{1/3}\pi^{1/2}} + O\left(\frac{1}{a_{k+1}} + \frac{1}{a_{k+2}}\right), \tag{57}$$

whereas for $k = K - 1$,

$$-\int_1^{b_{K-1}^*-1} F''(x)B_2(\{x\}) dx = -\frac{11}{12} + \log(2^{1/2}\pi^{1/2}) + O\left(\frac{1}{a_K}\right). \tag{58}$$

We have thus estimated all terms in (52). The claim for $0 \leq k \leq K - 2$ follows from (53), (55) and (57), whereas the claim for $k = K - 1$ follows from (54), (56) and (58). \square

Proof of Theorem 3. Let $\varepsilon_k = \varepsilon_k(N^*)$. Applying Proposition 13 and noting that $F_k(N^*) = 0$ for all k we get

$$\begin{aligned} \log P_{N^*}(\alpha) &= \sum_{k=0}^{K-1} \sum_{b=1}^{b_k^*-1} \log |2 \sin(\pi(bq_k\|q_k\alpha\| + \varepsilon_k))| + \sum_{k=0}^{K-1} \sum_{b=0}^{b_k^*-1} V_k(bq_k\|q_k\alpha\| + \varepsilon_k) \\ &\quad + \sum_{k=0}^{K-1} I_{\{b_k^* \geq 1\}} \log(2\pi(b_k^*q_k\|q_k\alpha\| + \varepsilon_k)) + O_T\left(\sum_{k=1}^K \frac{1}{a_k}\right) + O_\alpha(1). \end{aligned}$$

Note that $I_{\{b_k^* \geq 1\}} = I_{\{a_{k+1} \geq 2\}}$. The first sum was evaluated in Lemma 17. We can estimate the second sum by interpreting it as a Riemann sum and using Lemma 8(iii). Note that the endpoints are $\varepsilon_k = O(1/a_{k+1})$ and $(b_k^* - 1)q_k\|q_k\alpha\| + \varepsilon_k = \frac{5}{6} + O(1/a_{k+1})$. Since the points $bq_k\|q_k\alpha\| + \varepsilon_k$ for $b = 0, 1, \dots, b_k^* - 1$ lie in the interval $[-(1 - 1/(e^T + 2)), \frac{5}{6}]$, and since by Lemma 8 the function V_k is monotonically decreasing and satisfies $|V_k(x)| \ll_T (1 + \log a_k)/a_{k+1}$ on this interval, we have

$$\begin{aligned} &\sum_{b=0}^{b_k^*-1} V_k(bq_k\|q_k\alpha\| + \varepsilon_k) \\ &= \frac{1}{q_k\|q_k\alpha\|} \int_0^{\frac{5}{6}} V_k(x) dx + O_T\left(\frac{1 + \log a_k}{a_{k+1}}\right) \\ &= \int_0^{\frac{5}{6}} \left(\log \frac{a_k}{2\pi} - \frac{\Gamma'(1+x)}{\Gamma(1+x)}\right) dx + O_T\left(\frac{1 + \log(a_{k-1}a_k)}{a_k} + \frac{1 + \log a_k}{a_{k+1}}\right) + O_\alpha\left(\frac{1}{q_{k+1}}\right) \\ &= \frac{5}{6} \log \frac{a_k}{2\pi} - \log \Gamma\left(1 + \frac{5}{6}\right) + O_T\left(\frac{1 + \log(a_{k-1}a_k)}{a_k} + \frac{1 + \log a_k}{a_{k+1}}\right) + O_\alpha\left(\frac{1}{q_{k+1}}\right). \end{aligned}$$

Clearly,

$$I_{\{b_k^* \geq 1\}} \log(2\pi(b_k^* q_k \|q_k \alpha\| + \varepsilon_k)) = \log\left(\frac{5}{6} \cdot 2\pi\right) + O_T\left(\frac{1}{a_{k+1}}\right).$$

Summing over $0 \leq k \leq K - 1$, from the previous two formulas and [Lemma 17](#) we get

$$\begin{aligned} \log P_{N^*}(\alpha) &= \frac{1}{4\pi} \text{Vol}(4_1) \sum_{k=0}^{K-1} \frac{1}{q_k \|q_k \alpha\|} - \frac{1}{3} \sum_{k=0}^{K-2} \log a_{k+1} + \frac{1}{2} \log a_K - K \log \frac{\Gamma(\frac{1}{6})}{(2\pi)^{5/6}} + \frac{5}{6} \sum_{k=0}^{K-1} \log a_k \\ &\quad + K \left(-\frac{5}{6} \log(2\pi) - \log \Gamma\left(1 + \frac{5}{6}\right) + \log\left(\frac{5}{6} \cdot 2\pi\right) \right) + O_T\left(\sum_{k=1}^{K-1} \frac{1 + \log(a_k a_{k+1})}{a_{k+1}} \right) + O_\alpha(1). \end{aligned}$$

Observe that with a remarkable cancellation the coefficient of K vanishes. Indeed, by Euler’s reflection formula $\Gamma(x)\Gamma(1-x) = \pi/\sin(\pi x)$ we have $\Gamma(\frac{1}{6})\Gamma(\frac{5}{6}) = 2\pi$, and hence

$$-\log \frac{\Gamma(\frac{1}{6})}{(2\pi)^{5/6}} - \frac{5}{6} \log(2\pi) - \log \Gamma\left(1 + \frac{5}{6}\right) + \log\left(\frac{5}{6} \cdot 2\pi\right) = 0. \tag{59}$$

The previous formula for $\log P_{N^*}(\alpha)$ thus simplifies to

$$\log P_{N^*}(\alpha) = \frac{1}{4\pi} \text{Vol}(4_1) \sum_{k=0}^{K-1} \frac{1}{q_k \|q_k \alpha\|} + \frac{1}{2} \sum_{k=1}^K \log a_k + O_T\left(\sum_{k=1}^{K-1} \frac{1 + \log(a_k a_{k+1})}{a_{k+1}} \right) + O_\alpha(1).$$

Using, for example, property (iii) of continued fractions in [Section 3.1](#), we see that here $1/(q_k \|q_k \alpha\|) = a_{k+1} + O(1/a_k + 1/a_{k+2})$, and the claim follows. \square

7. Proof of Theorems 4 and 5

7.1. Quadratic irrationals. In this section we estimate the limit functions of $P_{q_k}(\alpha, (-1)^k x/q_k)$ for a given quadratic irrational α . In order to make our estimates uniform on the interval of interest $(-1, 1)$, we isolate the singularities at $x = -1$ and 1 . To this end, let us introduce the modified cotangent sum

$$V_k^*(x) := \sum_{\substack{1 \leq n \leq q_k - 1, \\ n \neq q_{k-1}, q_k - q_{k-1}}} \sin(\pi n \|q_k \alpha\|/q_k) \cot\left(\pi \frac{n(-1)^k p_k + x}{q_k}\right).$$

Observe that by excluding $n = q_{k-1}$ resp. $n = q_k - q_{k-1}$, we avoid $n(-1)^k p_k \equiv -1 \pmod{q_k}$ resp. $n(-1)^k p_k \equiv 1 \pmod{q_k}$. In particular, $V_k^*(x)$ does not have a singularity on $(-2, 2)$. The evaluation in [Lemma 8\(iii\)](#) has a perfect analogue for $V_k^*(x)$.

Lemma 18. *Assume (6). For any $k \geq 4$ and any $x \in (-2, 2)$,*

$$\frac{V_k^*(x)}{q_k \|q_k \alpha\|} = \log \frac{a_k}{2\pi} - \frac{\Gamma'(2+x)}{\Gamma(2+x)} + O\left(\frac{T + \log(a_{k-1} a_k)}{(2 - |x|) a_k}\right) + O_\alpha(1/q_k).$$

Proof. Following the proof of [Lemma 8](#) with obvious modifications, we get

$$V_k^*(x) = \pi \|q_k \alpha\| \sum_{\substack{1 \leq n \leq q_k - 1, \\ n \neq q_{k-1}, q_k - q_{k-1}}} \frac{n}{q_k} \cot\left(\pi \frac{n(-1)^k p_k + x}{q_k}\right) + O\left(\frac{\|q_k \alpha\|^3 q_k \log q_k}{2 - |x|}\right).$$

It remains to prove

$$\begin{aligned} C_k^*(x) &:= \sum_{\substack{1 \leq n \leq q_k - 1, \\ n \neq q_{k-1}, q_k - q_{k-1}}} \frac{n}{q_k} \cot\left(\pi \frac{np_k + (-1)^k x}{q_k}\right) \\ &= \frac{(-1)^k q_k}{\pi} \left(\log \frac{a_k}{2\pi} - \frac{\Gamma'(2+x)}{\Gamma(2+x)} + O\left(\frac{T + \log(a_{k-1} a_k)}{(2 - |x|) a_k}\right) \right) + O_\alpha(1). \end{aligned} \tag{60}$$

From [Lemma 7](#) we obtain

$$\begin{aligned} C_k^*(0) &= \sum_{n=1}^{q_k-1} \frac{n}{q_k} \cot\left(\pi \frac{np_k}{q_k}\right) - \frac{q_{k-1}}{q_k} \cot\left(\pi \frac{(-1)^{k+1}}{q_k}\right) - \frac{q_k - q_{k-1}}{q_k} \cot\left(\pi \frac{(-1)^k}{q_k}\right) \\ &= \frac{(-1)^k q_k}{\pi} \left(\log \frac{a_k}{2\pi} + \gamma - 1 + O\left(\frac{T + \log(a_{k-1} a_k)}{a_k}\right) \right) + O_\alpha(1), \end{aligned}$$

where $\gamma = -\Gamma'(1)/\Gamma(1)$ is the Euler–Mascheroni constant. Note that we used $\cot(\pi/q_k) = q_k/\pi + O(1)$ and that $q_{k-1}/q_k \ll 1/a_k$ is negligible. Following the proof of [Lemma 7](#) with obvious modifications (note that excluding $n = q_{k-1}$ and $n = q_k - q_{k-1}$ corresponds to excluding $a = \pm 1$), we get that the derivative of $C_k^*(x)$ satisfies

$$C_k^{*'}(x) = \frac{(-1)^{k+1} q_k}{\pi} \sum_{a=2}^{\infty} \frac{1}{(a+x)^2} + O\left(\frac{q_k(1 + \log a_k)}{(2 - |x|)^2 a_k}\right).$$

By integrating,

$$\begin{aligned} C_k^*(x) - C_k^*(0) &= \frac{(-1)^{k+1} q_k}{\pi} \sum_{a=2}^{\infty} \left(\frac{1}{a} - \frac{1}{a+x} \right) + O\left(\frac{q_k(1 + \log a_k)}{(2 - |x|) a_k}\right) \\ &= \frac{(-1)^{k+1} q_k}{\pi} \left(\gamma - 1 + \frac{\Gamma'(2+x)}{\Gamma(2+x)} + O\left(\frac{1 + \log a_k}{(2 - |x|) a_k}\right) \right), \end{aligned}$$

and [\(60\)](#) for general $x \in (-2, 2)$ follows. □

Next, let us introduce the appropriately modified version of $B_{k,M}(x)$ from [\(27\)](#): for any integers $k \geq 1$ and $0 \leq M < q_k$, let

$$B_{k,M}^*(x) := \log \frac{P_M^*(\alpha, (-1)^k x/q_k)}{P_M^*(p_k/q_k, (-1)^k x/q_k)} - \sum_{\substack{1 \leq n \leq M, \\ n \neq q_{k-1}, q_k - q_{k-1}}} \sin(\pi \|q_k \alpha\|/q_k) \cot\left(\pi \frac{n(-1)^k p_k + x}{q_k}\right),$$

where

$$P_M^*(\alpha, (-1)^k x/q_k) := \prod_{\substack{1 \leq n \leq M, \\ n \neq q_{k-1}, q_k - q_{k-1}}} |2 \sin(\pi(n\alpha + (-1)^k x/q_k))|,$$

and $P_M^*(p_k/q_k, (-1)^k x/q_k)$ is defined analogously.

Proposition 19. *Let $k \geq 1$ and $0 \leq M < q_k$ be integers, and assume that $q_k \|q_k \alpha\| \leq 2(1 - c_k)$ and $-2 < x \leq 2 - q_k \|q_k \alpha\|/(1 - c_k)$ with some $100/q_k^2 \leq c_k < 1$. Then*

$$-C \frac{\log(4/c_k)}{(2 - |x|)^2 a_{k+1}^2} \leq B_{k,M}^*(x) \leq C \frac{1}{a_{k+1}^2 q_k}$$

with a universal constant $C > 0$.

Proof. This is an obvious modification of the proof of [Proposition 11\(i\)](#). □

Proof of Theorem 4. Let $\alpha = [a_0; a_1, \dots, a_{k_0}, \overline{a_{k_0+1}, \dots, a_{k_0+p}}]$ be a quadratic irrational, and assume that $\max_{1 \leq r \leq p} (\log a_{k_0+r})/a_{k_0+r+1} \leq T$ with some constant $T \geq 1$. From [Corollary 10](#) we deduce

$$\begin{aligned} \log P_{q_k}(\alpha, (-1)^k x/q_k) &= \log \left(|2 \sin(\pi(\|q_k \alpha\| + x/q_k))| \frac{|\sin(\pi x)|}{|\sin(\pi x/q_k)|} \right) \\ &+ \sum_{n \in \{q_{k-1}, q_k - q_{k-1}\}} \log \frac{|\sin(\pi(n\alpha + (-1)^k x/q_k))|}{|\sin(\pi(np_k/q_k + (-1)^k x/q_k))|} + V_k^*(x) + B_{k,q_{k-1}}^*(x). \end{aligned} \quad (61)$$

Recall from the proof of [Lemma 6](#) that $q_k \|q_k \alpha\| \leq 1 - 1/(e^T + 2)$. Applying [Proposition 19](#) with $c_k = 1/(e^T + 2) \leq \frac{1}{2}$ we thus obtain that for all $|x| \leq \max\{1, 2 - 2/a_{k+1}\}$ and all large enough k (in terms of T),

$$|B_{k,q_{k-1}}^*(x)| \ll \frac{T}{(2 - |x|)^2 a_{k+1}^2}.$$

Applying [Lemma 18](#), formula (61) thus simplifies to

$$\begin{aligned} \log P_{q_k}(\alpha, (-1)^k x/q_k) &= \log \left(|2 \sin(\pi(\|q_k \alpha\| + x/q_k))| \frac{|\sin(\pi x)|}{|\sin(\pi x/q_k)|} \right) \\ &+ \sum_{n \in \{q_{k-1}, q_k - q_{k-1}\}} \log \frac{|\sin(\pi(n\alpha + (-1)^k x/q_k))|}{|\sin(\pi(np_k/q_k + (-1)^k x/q_k))|} + q_k \|q_k \alpha\| \left(\log \frac{a_k}{2\pi} - \frac{\Gamma'(2+x)}{\Gamma(2+x)} \right) \\ &+ O \left(\frac{T + \log(a_{k-1} a_k)}{(2 - |x|) a_k a_{k+1}} + \frac{T}{(2 - |x|)^2 a_{k+1}^2} \right) + O_\alpha(1/q_k). \end{aligned} \quad (62)$$

We now let $k \rightarrow \infty$ along the arithmetic progression $p\mathbb{N} + k_0 + r$, and claim that every term in (62) (except the first error term) converges. Indeed, we clearly have $q_k \|q_k \alpha\| \rightarrow C_r$ and $q_{k-1} \|q_k \alpha\| \rightarrow D_r$

with some constants $C_r, D_r > 0$ depending on α . The limit of the first term in (62) is

$$\log\left(|2 \sin(\pi(\|q_k \alpha\| + x/q_k))| \frac{|\sin(\pi x)|}{|\sin(\pi x/q_k)|}\right) \rightarrow \log\left(|2 \sin(\pi x)| \cdot \left|1 + \frac{C_r}{x}\right|\right).$$

Using trigonometric identities, we once again write

$$\frac{|\sin(\pi(n\alpha + (-1)^k x/q_k))|}{|\sin(\pi(np_k/q_k + (-1)^k x/q_k))|} = |1 + x_n + y_n|$$

with

$$x_n := \cos(\pi n(\alpha - p_k/q_k)) - 1 = \cos(\pi n\|q_k \alpha\|/q_k) - 1$$

and

$$y_n := \sin(\pi n\|q_k \alpha\|/q_k) \cot(\pi(n(-1)^k p_k/q_k + x/q_k)).$$

For both $n = q_{k-1}$ and $n = q_k - q_{k-1}$ we have $x_n \rightarrow 0$. For $n = q_{k-1}$,

$$y_{q_{k-1}} = \sin(\pi q_{k-1}\|q_k \alpha\|/q_k) \cot(\pi(x-1)/q_k) \rightarrow \frac{D_r}{x-1},$$

whereas for $n = q_k - q_{k-1}$,

$$y_{q_k - q_{k-1}} = \sin(\pi(q_k - q_{k-1})\|q_k \alpha\|/q_k) \cot(\pi(x+1)/q_k) \rightarrow \frac{C_r - D_r}{x+1}.$$

Note that we used $\cot(\pi y) = 1/(\pi y) + O(1)$ as $y \rightarrow 0$. Therefore the limit of the second term in (62) is

$$\sum_{n \in \{q_{k-1}, q_k - q_{k-1}\}} \log \frac{|\sin(\pi(n\alpha + (-1)^k x/q_k))|}{|\sin(\pi(np_k/q_k + (-1)^k x/q_k))|} \rightarrow \log\left|1 + \frac{D_r}{x-1}\right| + \log\left|1 + \frac{C_r - D_r}{x+1}\right|.$$

From (62) we thus get that for all $|x| \leq \max\{1, 2 - 2/a_{k_0+r+1}\}$,

$$\begin{aligned} \log G_{\alpha,r}(x) &= \log\left(|2 \sin(\pi x)| \cdot \left|1 + \frac{C_r}{x}\right|\right) + \log\left|1 + \frac{D_r}{x-1}\right| + \log\left|1 + \frac{C_r - D_r}{x+1}\right| \\ &\quad + C_r \left(\log \frac{a_{k_0+r}}{2\pi} - \frac{\Gamma'(2+x)}{\Gamma(2+x)}\right) + O\left(\frac{T + \log(a_{k_0+r-1} a_{k_0+r})}{(2-|x|)a_{k_0+r} a_{k_0+r+1}} + \frac{T}{(2-|x|)^2 a_{k_0+r+1}^2}\right), \end{aligned}$$

as claimed. □

7.2. Well approximable irrationals.

Proof of Theorem 5. Let α be such that $\sup_{k \geq 1} a_k = \infty$. It will be enough to prove that

$$P_{q_{k_m}}(\alpha, (-1)^{k_m} x/q_{k_m}) e^{-V_{k_m}(0)} \rightarrow |2 \sin(\pi x)| \quad \text{locally uniformly on } \mathbb{R} \tag{63}$$

for any increasing sequence of positive integers k_m such that $a_{k_m+1} \rightarrow \infty$ as $m \rightarrow \infty$; recall that $V_k(x)$ was defined in (24). Indeed, under the stronger assumption

$$\frac{1 + \log \max_{1 \leq \ell \leq k_m} a_\ell}{a_{k_m+1}} \rightarrow 0 \quad \text{as } m \rightarrow \infty,$$

we have $V_{k_m}(0) \rightarrow 0$ by Lemma 8(ii), and thus (63) holds without the factor $e^{-V_{k_m}(0)}$, as claimed. If in addition $(1 + \log a_k)/a_{k+1} \rightarrow 0$ (in particular, $a_{k+1} \rightarrow \infty$), then $V_k(0) \rightarrow 0$ by Lemma 8(iii), and (63) follows without the factor $e^{-V_{k_m}(0)}$ along the full sequence $k_m = m$, as claimed.

Fix a large integer $A > 0$, and let us prove that the convergence in (63) is uniform on $[-A, A]$. Let

$$S = S_k = \{1 \leq n \leq q_k - 1 : np_k \equiv a \pmod{q_k} \text{ with some integer } 0 < |a| \leq A\},$$

and let us introduce the modified cotangent sum

$$V_k^{**}(x) = \sum_{\substack{1 \leq n \leq q_k - 1, \\ n \notin S}} \sin(\pi n \|q_k \alpha\|/q_k) \cot\left(\pi \frac{n(-1)^k p_k + x}{q_k}\right).$$

Note that $V_k^{**}(x)$ does not have a singularity on $(-A - 1, A + 1)$. Following the steps in Section 7.1 with obvious modifications (see (61)), we get

$$\begin{aligned} \log P_{q_k}(\alpha, (-1)^k x/q_k) &= \log\left(|2 \sin(\pi(\|q_k \alpha\| + x/q_k))| \frac{|\sin(\pi x)|}{|\sin(\pi x/q_k)|}\right) + \sum_{n \in S} \log \frac{|\sin(\pi(n\alpha + (-1)^k x/q_k))|}{|\sin(\pi(np_k/q_k + (-1)^k x/q_k))|} \\ &\quad + V_k^{**}(x) + B_{k,q_k-1}^{**}(x). \end{aligned}$$

Here $B_{k,q_k-1}^{**}(x)$ is the perfect analogue of $B_{k,q_k-1}^*(x)$ in (61), and satisfies

$$|B_{k,q_k-1}^{**}(x)| \ll \frac{1}{a_{k+1}^2}, \quad x \in [-A, A],$$

by an obviously modified form of Proposition 19 with $c_k = \frac{1}{2}$. Following the steps in the proof of Lemma 8, it is easy to see that the derivative of $V_k^{**}(x)$ satisfies $|V_k^{**\prime}(x)| \ll 1/a_{k+1}$ on $[-A, A]$. Therefore for any $x \in [-A, A]$,

$$\begin{aligned} V_k^{**}(x) &= V_k^{**}(0) + O\left(\frac{A}{a_{k+1}}\right) \\ &= V_k(0) - \sum_{n \in S} \sin(\pi n \|q_k \alpha\|/q_k) \cot\left(\pi \frac{n(-1)^k p_k}{q_k}\right) + O\left(\frac{A}{a_{k+1}}\right) \\ &= V_k(0) + O\left(\sum_{0 < |a| \leq A} \|q_k \alpha\| \left| \cot\left(\pi \frac{a}{q_k}\right) \right| + \frac{A}{a_{k+1}}\right) \\ &= V_k(0) + O\left(\frac{A}{a_{k+1}}\right). \end{aligned}$$

By the previous three formulas and the usual trigonometric identities,

$$P_{q_k}(\alpha, (-1)^k x/q_k) e^{-V_k(0)} = |2 \sin(\pi x)| \frac{|\sin(\pi(\|q_k \alpha\| + x/q_k))|}{|\sin(\pi x/q_k)|} \left(\prod_{n \in S} |1 + x_n + y_n|\right) e^{O(A/a_{k+1})}$$

uniformly on $[-A, A]$, where

$$x_n := \cos(\pi n(\alpha - p_k/q_k)) - 1 = \cos(\pi n \|q_k \alpha\|/q_k) - 1$$

and

$$y_n := \sin(\pi n \|q_k \alpha\|/q_k) \cot(\pi(n(-1)^k p_k/q_k + x/q_k)).$$

To see (63), it will thus be enough to prove that

$$|2 \sin(\pi x)| \frac{|\sin(\pi(\|q_k \alpha\| + x/q_k))|}{|\sin(\pi x/q_k)|} \prod_{n \in S} |1 + x_n + y_n| \rightarrow |2 \sin(\pi x)| \quad \text{uniformly on } [-A, A] \quad (64)$$

along any subsequence $k = k_m$ such that $a_{k_m+1} \rightarrow \infty$.

First, let $x \in [-A, A] \setminus \bigcup_{a=-A}^A (a - \frac{1}{100}, a + \frac{1}{100})$. Then

$$\frac{|\sin(\pi(\|q_k \alpha\| + x/q_k))|}{|\sin(\pi x/q_k)|} \sim 1 + \frac{q_k \|q_k \alpha\|}{x},$$

as well as

$$|x_n| \ll \|q_k \alpha\|^2 \ll 1/a_{k+1} \quad \text{and} \quad |y_n| \ll_A 1/a_{k+1},$$

all uniformly in x . Hence

$$\begin{aligned} \frac{|\sin(\pi(\|q_k \alpha\| + x/q_k))|}{|\sin(\pi x/q_k)|} \prod_{n \in S} |1 + x_n + y_n| &\sim \left(1 + O\left(\frac{1}{a_{k+1}}\right)\right) \prod_{0 < |a| \leq A} \left|1 + O_A\left(\frac{1}{a_{k+1}}\right)\right| \\ &= 1 + O_A\left(\frac{1}{a_{k+1}}\right), \end{aligned}$$

uniformly in x . Thus the convergence in (64) is indeed uniform on $[-A, A] \setminus \bigcup_{a=-A}^A (a - \frac{1}{100}, a + \frac{1}{100})$.

Next, let $x \in (a - \frac{1}{100}, a + \frac{1}{100})$ with some $0 < |a| \leq A$. Then

$$\begin{aligned} |2 \sin(\pi x)| \prod_{n \in S} |1 + x_n + y_n| &= |2 \sin(\pi x)| \cdot \left|1 + O\left(\frac{1}{|x - a|a_{k+1}}\right)\right| \prod_{\substack{0 < |a'| \leq A \\ a' \neq a}} \left(1 + O_A\left(\frac{1}{a_{k+1}}\right)\right) \\ &= |2 \sin(\pi x)| + O_A\left(\frac{1}{a_{k+1}}\right), \end{aligned}$$

uniformly in $x \in (a - \frac{1}{100}, a + \frac{1}{100})$; indeed, $|\sin(\pi x)|/|x - a| \ll 1$ follows from the fact that $|\sin(\pi x)|$ has a zero at every integer. Therefore the convergence in (64) is also uniform on $(a - \frac{1}{100}, a + \frac{1}{100})$. Finally, let $x \in (-\frac{1}{100}, \frac{1}{100})$. Then

$$|2 \sin(\pi x)| \frac{|\sin(\pi(\|q_k \alpha\| + x/q_k))|}{|\sin(\pi x/q_k)|} \sim |2 \sin(\pi x)| \left(1 + \frac{q_k \|q_k \alpha\|}{x}\right) = |2 \sin(\pi x)| + O\left(\frac{1}{a_{k+1}}\right),$$

uniformly in $x \in (-\frac{1}{100}, \frac{1}{100})$. Therefore the convergence in (64) is uniform on $(-\frac{1}{100}, \frac{1}{100})$. This finishes the proof of (64). \square

Acknowledgements

Aistleitner is supported by the Austrian Science Fund (FWF), projects F-5512, I-3466, I-4945, P-34763 and Y-901. Borda is supported by FWF project Y-901.

References

- [Aistleitner and Borda 2022] C. Aistleitner and B. Borda, “Quantum invariants of hyperbolic knots and extreme values of trigonometric products”, *Math. Z.* **302**:2 (2022), 759–782. [MR](#) [Zbl](#)
- [Aistleitner et al. 2018] C. Aistleitner, G. Larcher, F. Pillichshammer, S. S. Eddin, and R. F. Tichy, “On Weyl products and uniform distribution modulo one”, *Monatsh. Math.* **185**:3 (2018), 365–395. [MR](#) [Zbl](#)
- [Aistleitner et al. 2020] C. Aistleitner, N. Technau, and A. Zafeiropoulos, “On the order of magnitude of Sudler products”, 2020. To appear in *Amer. J. Math.* [arXiv 2002.06602](#)
- [Allouche and Shallit 2003] J.-P. Allouche and J. Shallit, *Automatic sequences: theory, applications, generalizations*, Cambridge Univ. Press, 2003. [MR](#) [Zbl](#)
- [Avila and Jitomirskaya 2009] A. Avila and S. Jitomirskaya, “The ten martini problem”, *Ann. of Math. (2)* **170**:1 (2009), 303–342. [MR](#) [Zbl](#)
- [Bettin 2015] S. Bettin, “On the distribution of a cotangent sum”, *Int. Math. Res. Not.* **2015**:21 (2015), 11419–11432. [MR](#) [Zbl](#)
- [Bettin and Conrey 2013] S. Bettin and J. B. Conrey, “A reciprocity formula for a cotangent sum”, *Int. Math. Res. Not.* **2013**:24 (2013), 5709–5726. [MR](#) [Zbl](#)
- [Bettin and Drappeau 2022a] S. Bettin and S. Drappeau, “Limit laws for rational continued fractions and value distribution of quantum modular forms”, *Proc. Lond. Math. Soc. (3)* **125**:6 (2022), 1377–1425. [MR](#)
- [Bettin and Drappeau 2022b] S. Bettin and S. Drappeau, “Modularity and value distribution of quantum invariants of hyperbolic knots”, *Math. Ann.* **382**:3-4 (2022), 1631–1679. [MR](#) [Zbl](#)
- [Erdős and Szekeres 1959] P. Erdős and G. Szekeres, “On the product $\prod_{k=1}^n (1 - z^k)$ ”, *Acad. Serbe Sci. Publ. Inst. Math.* **13** (1959), 29–34. [MR](#) [Zbl](#)
- [Grepstad et al. 2019] S. Grepstad, L. Kaltenböck, and M. Neumüller, “A positive lower bound for $\liminf_{N \rightarrow \infty} \prod_{r=1}^N |2 \sin \pi r \varphi|$ ”, *Proc. Amer. Math. Soc.* **147**:11 (2019), 4863–4876. [MR](#) [Zbl](#)
- [Grepstad et al. 2020] S. Grepstad, L. Kaltenböck, and M. Neumüller, “On the asymptotic behavior of the sine product $\prod_{r=1}^n |2 \sin \pi r \alpha|$ ”, pp. 103–115 in *Discrepancy theory*, edited by D. Bilyk et al., Radon Ser. Comput. Appl. Math. **26**, De Gruyter, Berlin, 2020. [MR](#) [Zbl](#)
- [Grepstad et al. 2022] S. Grepstad, M. Neumüller, and A. Zafeiropoulos, “On the order of magnitude of Sudler products II”, (online publication October 2022). To appear in *Int. J. Number Theory*.
- [Knill and Tangerman 2011] O. Knill and F. Tangerman, “Self-similarity and growth in Birkhoff sums for the golden rotation”, *Nonlinearity* **24**:11 (2011), 3115–3127. [MR](#) [Zbl](#)
- [Lubinsky 1999] D. S. Lubinsky, “The size of $(q; q)_n$ for q on the unit circle”, *J. Number Theory* **76**:2 (1999), 217–247. [MR](#) [Zbl](#)
- [Lubinsky 2003] D. S. Lubinsky, “Rogers–Ramanujan and the Baker–Gammel–Wills (Padé) conjecture”, *Ann. of Math. (2)* **157**:3 (2003), 847–889. [MR](#) [Zbl](#)
- [Maier and Rassias 2019] H. Maier and M. T. Rassias, “Explicit estimates of sums related to the Nyman–Beurling criterion for the Riemann hypothesis”, *J. Funct. Anal.* **276**:12 (2019), 3832–3857. [MR](#) [Zbl](#)
- [Murakami 2011] H. Murakami, “An introduction to the volume conjecture”, pp. 1–40 in *Interactions between hyperbolic geometry, quantum topology and number theory*, edited by A. Champanerker et al., Contemp. Math. **541**, Amer. Math. Soc., Providence, RI, 2011. [MR](#) [Zbl](#)
- [Murakami and Murakami 2001] H. Murakami and J. Murakami, “The colored Jones polynomials and the simplicial volume of a knot”, *Acta Math.* **186**:1 (2001), 85–104. [MR](#) [Zbl](#)

- [Rockett and Szűsz 1992] A. M. Rockett and P. Szűsz, *Continued fractions*, World Sci., River Edge, NJ, 1992. [MR](#) [Zbl](#)
- [Schmidt 1980] W. M. Schmidt, *Diophantine approximation*, Lecture Notes in Mathematics **785**, Springer, 1980. [MR](#) [Zbl](#)
- [Sudler 1964] C. Sudler, Jr., “An estimate for a restricted partition function”, *Quart. J. Math. Oxford Ser. (2)* **15** (1964), 1–10. [MR](#) [Zbl](#)
- [Vasyunin 1995] V. I. Vasyunin, “On a biorthogonal system associated with the Riemann hypothesis”, *Algebra i Analiz* **7:3** (1995), 118–135. In Russian; translated in *St. Petersburg Math. J.* **7:3** (1996), 405–419. [MR](#) [Zbl](#)
- [Verschueren and Mestel 2016] P. Verschueren and B. Mestel, “Growth of the Sudler product of sines at the golden rotation number”, *J. Math. Anal. Appl.* **433:1** (2016), 200–226. [MR](#) [Zbl](#)
- [Zagier 2010] D. Zagier, “Quantum modular forms”, pp. 659–675 in *Quanta of maths*, edited by E. Blanchard et al., Clay Math. Proc. **11**, Amer. Math. Soc., Providence, RI, 2010. [MR](#) [Zbl](#)

Communicated by Peter Sarnak

Received 2021-03-18

Revised 2022-01-18

Accepted 2022-05-10

aistleitner@math.tugraz.at

*Institute of Analysis and Number Theory, Graz University of Technology,
Graz, Austria*

borda@math.tugraz.at

*Institute of Analysis and Number Theory, Graz University of Technology,
Graz, Austria*

Alfréd Rényi Institute of Mathematics, Budapest, Hungary

Free rational curves on low degree hypersurfaces and the circle method

Tim Browning and Will Sawin

We use a function field version of the Hardy–Littlewood circle method to study the locus of free rational curves on an arbitrary smooth projective hypersurface of sufficiently low degree. On the one hand this allows us to bound the dimension of the singular locus of the moduli space of rational curves on such hypersurfaces and, on the other hand, it sheds light on Peyre’s reformulation of the Batyrev–Manin conjecture in terms of slopes with respect to the tangent bundle.

1. Introduction	719
2. Examples	723
3. Vector bundles on \mathbb{P}^1	725
4. The circle method: identification of major arcs	728
5. The circle method: minor arcs	734
6. Peyre’s freedom counting function	745
Acknowledgements	747
References	748

1. Introduction

Let $X \subset \mathbb{P}^{n-1}$ be a smooth hypersurface of degree $d \geq 3$, over a field K whose characteristic exceeds d if it is positive. This paper has two aspects. On the one hand, motivated by questions in algebraic geometry, we shall be interested in the locus of points corresponding to free rational curves inside the moduli space $\mathcal{M}_{0,0}(X, e)$ of degree e rational curves on X . On the other hand, by working over a finite field, we shall establish a function field analogue of a recent conjecture due to Peyre [2017] about the distribution of “sufficiently free” rational points of bounded height on Fano varieties.

1A. Geometry. The expected dimension of $\mathcal{M}_{0,0}(X, e)$ is $(n - d)e + n - 5$, a fact that is known to hold for generic X if $n \geq d + 3$, thanks to Riedl and Yang [2019]. It follows from work of Browning and Vishe [2017] that $\mathcal{M}_{0,0}(X, e)$ is irreducible and has the expected dimension for any smooth X , provided that $n > (5d - 4)2^{d-1}$. Our first result strengthens this.

Theorem 1.1. *Let $d \geq 3$, let $e \geq 1$ and let $n > (2d - 1)2^{d-1}$. Then $\mathcal{M}_{0,0}(X, e)$ is an irreducible locally complete intersection of the expected dimension.*

MSC2020: primary 14H10; secondary 11D45, 11P55, 14G05, 14J20.

Keywords: circle method, free rational curve, function field, hypersurface.

We can also bound the dimension of the singular locus of $\mathcal{M}_{0,0}(X, e)$, as follows.

Theorem 1.2. *Let $d \geq 3$, let $e \geq 1$ and let $n > 3(d-1)2^{d-1}$. Then the space $\mathcal{M}_{0,0}(X, e)$ is smooth outside a set of codimension at least*

$$\left(\frac{n}{2^{d-2}} - 6(d-1) \right) \left(1 + \left\lfloor \frac{e+1}{d-1} \right\rfloor \right).$$

In particular, whenever these inequalities are satisfied, it is generically smooth and reduced.

For $n \geq 2d+1$ and generic X of degree $d \geq 3$, Harris, Roth and Starr [Harris et al. 2004] have also shown that $\mathcal{M}_{0,0}(X, e)$ is generically smooth. Note that, provided $n > 3(d-1)2^{d-1}$, the codimension goes to ∞ in Theorem 1.2 when either e or n does, with d fixed. Moreover, when both e and n are large with respect to d , the codimension is at least approximately $1/(2^{d-2}(d-1))$ of the total dimension.

Our work addresses some questions of Eisenbud and Harris [2016, Section 6.8.1] concerning the Fano variety of lines $F_1(X) = \mathcal{M}_{0,0}(X, 1)$ associated to a smooth hypersurface $X \subset \mathbb{P}^{n-1}$ of degree d . Specifically, their question (a) asks whether $F_1(X)$ is reduced and irreducible if $n > d+1$ and (b) asks whether the dimension of the singular locus of $F_1(X)$ can be bounded in terms of d alone. Theorems 1.1 and 1.2 answer the first question affirmatively for $n > 3(d-1)2^{d-1}$ and give some weak evidence in support of the second question, by showing that it grows with n more slowly than the dimension of the whole space. Furthermore, we handle the analogous conjectures with higher degree curves, with no loss in the dependence on n , meaning that for large enough e we do better than their predicted bound $d \leq n/e$.

By comparison, Starr [2003] has proved that if $n \geq d+e$ and X is generic, then $\mathcal{M}_{0,0}(X, e)$ has canonical singularities, which implies in particular that it is smooth outside a set of codimension at least 2. It does not seem possible that our method will prove that $\mathcal{M}_{0,0}(X, e)$ has canonical singularities. By [Mustaa 2001] and [Lang and Weil 1954] this is equivalent to the conjunction of an infinite sequence of Diophantine estimates (in the spirit of Definition 3.7), but for fixed n, d and e it seems unlikely that the circle method is able to handle more than finitely many of them. In unpublished work, Starr and Tian use a bend-and-break approach to produce a less restrictive lower bound for the codimension of the singular locus for a general hypersurface $X \subset \mathbb{P}^{n-1}$ of degree d . However, their method never proves a lower bound for the codimension greater than n , whereas our work achieves this if e is sufficiently large.

Comparing the various results, we see that Theorem 1.2 holds for a much more restricted range of n (unless e is very large relative to d) but it is valid for an arbitrary smooth hypersurface, rather than just a general one.

It should be possible to adapt our strategy to prove results about moduli spaces of genus g curves on X . However, the codimension we obtain for the whole moduli space will not be any better than the codimension we can prove for the space of maps from a fixed genus g curve to X . In particular the codimension will shrink as g grows, so the bound obtained would only be suitable for e sufficiently large with respect to g .

Let \mathcal{T}_X be the tangent bundle associated to the smooth hypersurface $X \subset \mathbb{P}^{n-1}$ (as defined in [Hartshorne 1977, page 180], for example). Our remaining result deals specifically with free curves and so we recall the definition here.

Definition 1.3. Let $c: \mathbb{P}^1 \rightarrow X$ be a rational curve and let $\varrho \in \mathbb{Z}$. We say that c is ϱ -free if $c^* \mathcal{T}_X \otimes \mathcal{O}_{\mathbb{P}^1}(-\varrho)$ is globally generated.

We shall follow common convention and say that c is free if it is 0-free, and very free if it is 1-free. One easily checks that this agrees with the standard definition that c is free if $c^* \mathcal{T}_X$ is globally generated and very free if $c^* \mathcal{T}_X$ is ample. The definition of free curves goes back to pioneering work of Kollár, Miyaoka and Mori [Kollár et al. 1992a, Section 1] on rational connectedness for Fano varieties, and they feature heavily in work of Kollár [1996, Section II.3]. We have taken Definition 1.3 from work of Debarre [2001, Definition 4.5], which appears to be the first time that the notion of being ϱ -free occurs, for varying $\varrho \in \mathbb{Z}$.

Remark 1.4. If c is a ϱ -free rational curve on X then it follows from Definition 1.3 that $\deg(c^* \mathcal{T}_X) \geq \text{rank}(c^* \mathcal{T}_X)\varrho$. In general, the pull-back of the tangent bundle has rank $n - 2$ and degree $e(n - d)$. In this way we see that no degree e rational curve on X is ever $(\lfloor e(n - d)/(n - 2) \rfloor + 1)$ -free. If $d \geq 2$ then this implies that $\varrho \leq e$, for any ϱ -free rational curve $\mathbb{P}^1 \rightarrow X$.

We let $U_\varrho \subset \mathcal{M}_{0,0}(X, e)$ be the Zariski open set that parametrizes degree e maps from \mathbb{P}^1 to X that are ϱ -free. We write $Z_\varrho = \mathcal{M}_{0,0}(X, e) \setminus U_\varrho$ for the complement. This is the closed set parametrizing degree e maps $\mathbb{P}^1 \rightarrow X$ that are not ϱ -free. We shall prove the following bound for its dimension.

Theorem 1.5. Let $d \geq 3$ and $n > 3(d - 1)2^{d-1}$. Assume that $\varrho \geq -1$ and

$$e \geq (\varrho + 1) \left(2 + \frac{1}{d - 2} \right). \quad (1-1)$$

Then

$$\dim Z_\varrho \leq (n - d)e + n - 5 + 2(d - 1) \left\lfloor \frac{\varrho + 1}{2} \right\rfloor - \left(\frac{n}{2^{d-2}} - 6(d - 1) \right) \left(1 + \left\lfloor \frac{e - \varrho}{d - 1} \right\rfloor - \left\lfloor \frac{\varrho + 1}{2} \right\rfloor \right). \quad (1-2)$$

The notion of free rational curves was originally introduced as a tool to study uniruled and rational connectedness properties of varieties. Taking $\varrho = 1$ it follows from Theorems 1.1 and 1.5 that $U_1 \neq \emptyset$ if K is algebraically closed and e is sufficiently large. Hence, by appealing to [Debarre 2001, Corollary 4.17], we deduce that any smooth hypersurface $X \subset \mathbb{P}^{n-1}$ of degree d is rationally connected if $d \geq 3$ and $n > 3(d - 1)2^{d-1}$. This recovers a weak form of the well-known result, independently due to Campana [1992] and Kollár, Miyaoka and Mori [Kollár et al. 1992b] that Fano varieties are rationally connected. In fact both proofs use reduction to characteristic p , but they use different properties of characteristic p varieties, with [Kollár et al. 1992b] relying on Frobenius pull-back and our work using the Lang–Weil estimates.

Theorem 1.2 is derived from Theorem 1.5, which is proved using analytic number theory and builds on an approach employed by Browning and Vishe [2017]. (Theorem 1.1 uses essentially the same approach as [loc. cit.], with one improvement to a key lemma.) One begins by working over a finite field $K = \mathbb{F}_q$ of characteristic $> d$. We bound the dimension of Z_ϱ by counting the number of points defined over a finite extension of \mathbb{F}_q that lie in it. In Section 3, we will give an explicit description of this locus in terms

of a system of two Diophantine equations defined over the function field $\mathbb{F}_q(T)$. Let $f \in \mathbb{F}_q[x_1, \dots, x_n]$ be a nonsingular form of degree d that defines the hypersurface $X \subset \mathbb{P}^{n-1}$. Given $\varrho \in \mathbb{Z}$, we shall see that the primary counting function of interest to us, denoted $N_\varrho(q, e, f)$, is the one that counts vectors $(\mathbf{g}, \mathbf{h}) \in \mathbb{F}_q[T]^{2n}$, where g_1, \dots, g_n have degree at most e and no common zero, with at least one of degree exactly e , and where h_1, \dots, h_n have degree at most $e - 1 - \varrho$, such that

$$f(g_1, \dots, g_n) = 0 \quad \text{and} \quad \sum_{i=1}^n h_i \frac{\partial f}{\partial x_i}(g_1, \dots, g_n) = 0. \quad (1-3)$$

Since each partial derivative of f is a degree $d - 1$ polynomial, we obtain a linear equation for $\mathbf{h} \in \mathbb{F}_q[T]^n$ where the coefficients have degree at most $(d - 1)e$ in T . Standard heuristics lead us to expect that, for typical \mathbf{g} , the number of available \mathbf{h} is $q^{(e-\varrho)(n-1)-(d-1)e} = q^{e(n-d)-\varrho(n-1)}$. (In fact, we shall see in Lemmas 3.4 and 3.5 that this is true only if the map $\mathbb{P}^1 \rightarrow X$ represented by \mathbf{g} is ϱ -free.) Thus we expect that $N_\varrho(q, e, f)$ is approximated by $q^{e(n-d)-\varrho(n-1)}N(q, e, f)$, where $N(q, e, f)$ is the number of vectors $\mathbf{g} \in \mathbb{F}_q[T]^n$ such that $f(\mathbf{g}) = 0$, where g_1, \dots, g_n have degree at most e and no common zero, with at least one of degree exactly e .

In Section 4, we apply the function field version of the Hardy–Littlewood circle method to study the system of degree d equations (1-3), expressing the number of solutions as an integral of an exponential sum. We shall show that the major arc contribution to this integral cancels almost exactly with the expected approximation $q^{e(n-d)-\varrho(n-1)}N(q, e, f)$. In Section 5, we prove an upper bound on all other arcs, taking special care to make all of our implied constants depend explicitly on the size of the finite field q . The standard way of proceeding involves $d - 1$ applications of Weyl differencing, a process that would ultimately require $n > 3(d - 1)2^d$ variables overall. We shall gain a 50% reduction in the number of variables by exploiting the special shape of the Diophantine system (1-3). Finally, we bring everything together and apply the Lang–Weil estimates [Lang and Weil 1954] to turn the bound for $\#Z_\varrho(\mathbb{F}_q)$ into a bound for the dimension of Z_ϱ . An application of spreading-out shows that the dimension bound holds over an arbitrary base field K such that $\text{char}(K) > d$ if it is positive.

1B. Arithmetic. In our geometric investigation of Z_ϱ we take the point of view that e and ϱ are fixed and $q \rightarrow \infty$. In this subsection we assume that the finite field is fixed, but we allow the parameters e and ϱ to tend to infinity appropriately.

Suppose that V is a smooth projective geometrically integral Fano variety defined over a number field K . For suitable Zariski open subsets $U \subset V$ the Batyrev–Manin conjecture [Franke et al. 1989] makes a precise prediction about the asymptotic behavior of the counting function

$$N_U(B) = \#\{x \in U(K) : H_{\omega_V^{-1}}(x) \leq B\},$$

as $B \rightarrow \infty$, where $H_{\omega_V^{-1}} : V(K) \rightarrow \mathbb{R}$ is an anticanonical height function. These conjectures are flawed, however, since it has been discovered that the presence of Zariski dense thin sets in $V(K)$ may skew the expected asymptotics. Recently, Peyre [2017] has embarked on an ambitious program to repair the

conjecture by associating a measure of “freeness” $\ell(x) \in [0, 1]$ to any $x \in V(K)$ and only counting those rational points for which $\ell(x) \geq \varepsilon_B$, where ε_B is a function of B decreasing to zero sufficiently slowly; see [loc. cit., Definition 6.11] for a precise statement. Peyre’s function $\ell(x)$ is defined using Arakelov geometry and the theory of slopes associated to the tangent bundle \mathcal{T}_V .

We can lend support to Peyre’s freedom prediction [loc. cit., Section 6] by studying smooth hypersurfaces of low degree in the setting of global fields of positive characteristic. Let $X \subset \mathbb{P}^{n-1}$ be a smooth hypersurface of degree d defined over a finite field \mathbb{F}_q whose characteristic exceeds d . We put

$$N_X^{\varepsilon\text{-free}}(B) = \#\{x \in X(K) : \ell(x) \geq \varepsilon, H_{-\omega_X}(x) \leq q^B\}, \quad (1-4)$$

where $K = \mathbb{F}_q(T)$ is the rational function field and $\ell(x)$ will be defined in Section 6. The expectation is that for a suitable range of ε , $N_X^{\varepsilon\text{-free}}(B)$ should have the same asymptotic behavior as the usual counting function $N_X(B)$, as $B \rightarrow \infty$. The following result confirms this and will be proved in Section 6.

Theorem 1.6. *Let $d \geq 3$, let $n > 3(d-1)2^{d-1}$ and let*

$$0 \leq \varepsilon < \frac{n-1}{(n-d)(d-1)^2 2^{d-1}}.$$

Then there exists $\delta > 0$ such that

$$N_X^{\varepsilon\text{-free}}(B) = c_X q^B + O(q^{(1-\delta)B}),$$

as $B \rightarrow \infty$, where c_X is the function field analogue of the constant predicted by Peyre [1995]. Furthermore, the implied constant only depends on q and f .

Note that this result does not require ε_B to decrease to zero, but only to stay below some fixed constant. This may be because the hypersurface X has Picard rank one, since Peyre [2017, Section 7.2] has shown that for the product $\mathbb{P}^1 \times \mathbb{P}^1$ one requires $\varepsilon_B \rightarrow 0$ for the asymptotic formula to be true. Finally, one can see from the arguments in Theorem 1.6 that we can take the upper bound for ε to be significantly greater than $(n-1)/((n-d)(d-1)^2 2^{d-1})$ when n is large. (In fact, the cutoff is allowed to approach $1/(d+1)$ as $n \rightarrow \infty$.)

With appropriate adjustments to the proof of Theorem 1.6, it is also possible to handle the corresponding result for smooth hypersurfaces of low degree defined over \mathbb{Q} , with Poisson summation taking the place of the Riemann–Roch arguments that feature in Section 3. This is the object of our concurrent work [Browning and Sawin 2020a].

2. Examples

As usual, $X \subset \mathbb{P}^{n-1}$ is assumed to be a smooth hypersurface of degree $d \geq 3$, over a field K whose characteristic is either 0 or $> d$. While the latter condition arises very naturally in our argument (as explained in Remark 5.5), the following result shows that the statement of Theorem 1.5 is actually false when it is dropped.

Lemma 2.1. *Let $K = \overline{\mathbb{F}}_p$ for a prime p and let $X \subset \mathbb{P}^{n-1}$ be the Fermat hypersurface*

$$x_1^d + \dots + x_n^d = 0.$$

Assume that $p \nmid d$ and $d \neq ap^r - 1$ for any $r \in \mathbb{N}$ and $a \in \{0, \dots, p - 1\}$. Then X is smooth, none of the curves in $\mathcal{M}_{0,0}(X, 1)$ are (-1) -free, and $\dim \mathcal{M}_{0,0}(X, 1) > 2n - d - 5$.

Proof. The moduli space of n -tuples of polynomials of degree ≤ 1 satisfying the equation $x_1^d + \dots + x_n^d = 0$ is a GL_2 -bundle over the moduli stack $\mathcal{M}_{0,0}(X, 1)$ parametrizing lines in X , because for each line we can choose any basis of the corresponding two-dimensional vector space. Thus its dimension is equal to $4 + \dim \mathcal{M}_{0,0}(X, 1)$. This space is cut out by $d + 1$ equations in $2n$ variables, where $\binom{d}{i}$ divides all coefficients of the i -th equation, for $0 \leq i \leq d$. By Lucas' theorem it follows that $p \mid \binom{d}{i}$ if and only if at least one of the base p digits of i is greater than the corresponding base p digit of d . In this way we see that $p \mid \binom{d}{i}$ for some $0 \leq i \leq d$ if and only if d does not take the form $ap^r - 1$ for some $a \in \{0, \dots, p - 1\}$. But then the space is cut out by fewer than $d + 1$ equations in $2n$ variables. This implies that it has dimension greater than $2n - d - 1$, whence $\dim \mathcal{M}_{0,0}(X, 1) > 2n - d - 5$. Furthermore, since the dimension near each curve is greater than the expected dimension, it follows from Lemma 3.1 that they are not (-1) -free. Finally, the Fermat hypersurface is smooth over K if and only if $p \nmid d$. \square

This example generalizes a discussion of Debarre [2001, Section 2.15]. It shows that for typical $p < d$ the statements of Theorems 1.1 and 1.5 are false for fields of characteristic p .

Returning to the general setting, the following result provides examples of curves that are not ϱ -free.

Lemma 2.2. *Let $d, m, n \in \mathbb{N}$ with $d \geq 3$ and $m \leq n/2$. Let K be an infinite field. There exists a nonsingular form $f(x_1, \dots, x_n)$ over K of degree d , such that*

$$f(x_1, \dots, x_m, 0, \dots, 0) = \frac{\partial f}{\partial x_j}(x_1, \dots, x_m, 0, \dots, 0) = 0$$

for all x_1, \dots, x_m and all $j \leq n - m$. For such a polynomial, every map $c : \mathbb{P}^1 \rightarrow X$ of degree e that factors through $\mathbb{P}^{m-1} \subseteq X \subseteq \mathbb{P}^{n-1}$ fails to be $(\lfloor e(m - d)/(m - 1) \rfloor + 1)$ -free. The moduli space of such rational curves has dimension $m(e + 1) - 4$.

Let $X \subset \mathbb{P}^{n-1}$ be a smooth hypersurface with underlying polynomial f , as in the lemma. Taking $m = d$ and $\varrho = 0$, we see that when $n > 2d$ the space Z_1 of non-very-free rational curves $\mathbb{P}^1 \rightarrow X$ of degree e has dimension at least $d(e + 1) - 4$.

Proof of Lemma 2.2. Without the nonsingularity condition, the space of such polynomials is linear. The singular polynomials form a closed subset. To prove the existence, it is sufficient to show that this subset has codimension 1. The set of singular polynomials is the projection from the product of this linear space with \mathbb{P}^{n-1} of the set of pairs of a point and a polynomial singular at that point. For elements in $\mathbb{P}^{m-1} \subseteq \mathbb{P}^{n-1}$, the space of polynomials singular at that point has codimension m , as it is defined by the m independent conditions $\frac{\partial f}{\partial x_j}(x_1, \dots, x_m, 0, \dots, 0) = 0$ for $n - m + 1 \leq j \leq n$. For all other elements, we claim that the n conditions $\frac{\partial f}{\partial x_j}(x_1, \dots, x_n) = 0$ for $1 \leq j \leq n$ define a codimension n subspace. To

see this we may take a linear form l in the last $n - m$ coordinates that is nonzero at that point. Then the n -dimensional space of polynomials generated by $x_j l^{d-1}$ for $1 \leq j \leq n$ lie in the linear subspace, since $d - 1 \geq 2$. But only the zero element in that subspace satisfies all n conditions. It follows that the singular locus is the union of the projection of a codimension m bundle on \mathbb{P}^{m-1} and a codimension n bundle on its complement in \mathbb{P}^{n-1} . Thus the singular locus has codimension at least one, as desired.

For the freeness, we use the Euler exact sequence

$$0 \rightarrow \mathcal{O}_{\mathbb{P}^{n-1}} \rightarrow \mathcal{O}_{\mathbb{P}^{n-1}}(1)^n \rightarrow \mathcal{T}_{\mathbb{P}^{n-1}} \rightarrow 0. \quad (2-1)$$

Consider the map $\mathcal{O}_{\mathbb{P}^{n-1}}(1)^n \rightarrow \mathcal{O}_{\mathbb{P}^{n-1}}(1)^m$ given by projection onto the last m factors. Because $m \leq n/2$ the composition of this projection with the map $\mathcal{O}_{\mathbb{P}^{n-1}} \rightarrow \mathcal{O}_{\mathbb{P}^{n-1}}(1)^n$ vanishes on \mathbb{P}^{m-1} . So over \mathbb{P}^{m-1} , we obtain a map $\mathcal{T}_{\mathbb{P}^{n-1}} \rightarrow \mathcal{O}_{\mathbb{P}^{n-1}}(1)^m$.

Next consider the exact sequence $0 \rightarrow \mathcal{T}_{\mathbb{P}^{n-1}} \rightarrow \mathcal{T}_X \rightarrow \mathcal{O}_X(d) \rightarrow 0$ on X . The second map of this sequence is the dot product with the derivative of f . By assumption on f , restricted to \mathbb{P}^{m-1} , this map factors through the projection onto the last m vectors. Hence we obtain an exact sequence

$$0 \rightarrow \mathcal{V} \rightarrow \mathcal{O}_{\mathbb{P}^{m-1}}(1)^m \rightarrow \mathcal{O}_{\mathbb{P}^{m-1}}(d) \rightarrow 0$$

whose kernel \mathcal{V} is a vector bundle on \mathbb{P}^{m-1} of degree $m - d$, which arises as a quotient of \mathcal{T}_X .

For $c : \mathbb{P}^1 \rightarrow X$ a map of degree e whose image lies in \mathbb{P}^{m-1} , $c^*\mathcal{V}$ is a vector bundle of degree $e(m - d)$ on \mathbb{P}^1 which arises as a quotient of $c^*\mathcal{T}_X$. Because $c^*\mathcal{V}$ splits as a direct sum of $m - 1$ line bundles, it must contain some line bundle summand of degree at most $e(m - d)/(m - 1)$, and we can round down to the nearest integer. Hence $c^*\mathcal{T}_X$ has some line bundle summand of degree at most $\lfloor e(m - d)/(m - 1) \rfloor$ and hence c is not $(\lfloor e(m - d)/(m - 1) \rfloor + 1)$ -free.

The dimension estimate is the standard calculation for the moduli space of rational curves in projective space. \square

Even for a general hypersurface there are some non-very-free curves. Indeed, for such a variety, the moduli space of lines has dimension $2n - d - 5$, and each line admits a $(2e + 1)$ -dimensional moduli space of degree e maps from \mathbb{P}^1 to that line. Because the pull-back of the tangent bundle to a line has rank $n - 2$ and degree $n - d$, it contains some summand of degree at most 0 as soon as $d \geq 2$, and so every pull-back of it has a summand of the same degree, and so these degree e coverings of lines fail to be 1-free. Hence, for a general hypersurface $X \subset \mathbb{P}^{n-1}$ of degree d , we have $\dim Z_1 \geq 2(n + e) - d - 7$.

These examples show that the dimension of the moduli space of non-very-free curves can grow linearly in n and it can grow linearly in e . We do not know if it can grow linearly in ne , as the dimension of $\mathcal{M}_{0,0}(X, e)$ does.

3. Vector bundles on \mathbb{P}^1

Let f be a homogeneous polynomial of degree d in n variables over a field K and let $X \subset \mathbb{P}^{n-1}$ be its projective zero locus. Assume that X is smooth and let \mathcal{T}_X be its tangent bundle. In this section we

investigate the geometry of ϱ -free rational curves $c : \mathbb{P}^1 \rightarrow X$, in the sense of [Definition 1.3](#). It turns out that there is a natural characterization of the (-1) -free curves, which we recall here.

Lemma 3.1. *A rational curve $c : \mathbb{P}^1 \rightarrow X$ of degree e is (-1) -free if and only if, in a neighborhood of c , the moduli space of rational curves on X is smooth of dimension $(n - d)e + n - 5$.*

Under the assumptions of [Theorem 1.1](#) or [\[Riedl and Yang 2019\]](#), $\mathcal{M}_{0,0}(X, e)$ has dimension $(n - d)e + n - 5$, so this is simply equivalent to $\mathcal{M}_{0,0}(X, e)$ being smooth at c .

Proof of Lemma 3.1. The tangent space of the moduli space of rational curves at c is

$$H^0(\mathbb{P}^1, c^* \mathcal{T}_X) / H^0(\mathbb{P}^1, \mathcal{T}_{\mathbb{P}^1}).$$

Note that $H^0(\mathbb{P}^1, \mathcal{T}_{\mathbb{P}^1})$ has dimension 3. By Riemann–Roch,

$$\dim H^0(\mathbb{P}^1, c^* \mathcal{T}_X) - \dim H^1(\mathbb{P}^1, c^* \mathcal{T}_X) = \dim(c^* \mathcal{T}_X) + \deg(c^* \mathcal{T}_X) = n - 2 + e(n - d).$$

Hence if c is a smooth point on a component of dimension $n - 5 + e(n - d)$ then $H^0(\mathbb{P}^1, c^* \mathcal{T}_X)$ has dimension $n - 2 + e(n - d)$ and so $H^1(\mathbb{P}^1, c^* \mathcal{T}_X)$ vanishes. Thus [\[Debarre 2001, Remark 4.6\]](#) implies that c is (-1) -free.

Conversely if c is (-1) -free then $H^1(\mathbb{P}^1, c^* \mathcal{T}_X)$ vanishes by [\[loc. cit., Remark 4.6\]](#), so deformations are unobstructed. Thus the moduli space is smooth at c , and the dimension of the tangent space to the moduli space is $n - 5 + e(n - d)$. □

Let $\hat{\mathcal{T}}_X$ be the inverse image of $\mathcal{T}_X \subseteq \mathcal{T}_{\mathbb{P}^{n-1}}$ under the map $\mathcal{O}_{\mathbb{P}^{n-1}}(1)^n \rightarrow \mathcal{T}_{\mathbb{P}^{n-1}}$ in the Euler sequence (2-1). This yields

$$0 \rightarrow \mathcal{O}_X \rightarrow \hat{\mathcal{T}}_X \rightarrow \mathcal{T}_X \rightarrow 0,$$

so that in particular $\hat{\mathcal{T}}_X$ is a vector bundle of rank $n - 1$ on X . With this in mind, we refine [Definition 1.3](#) as follows.

Definition 3.2. We say that $c : \mathbb{P}^1 \rightarrow X$ is strongly ϱ -free if $c^* \hat{\mathcal{T}}_X \otimes \mathcal{O}_{\mathbb{P}^1}(-\varrho)$ is globally generated.

We thank Paul Nelson for asking a question that suggested the above definition, and which turns out to simplify our argument compared to studying the tangent bundle directly.

Lemma 3.3. *If c is strongly ϱ -free, then it is ϱ -free.*

Proof. This follows from the fact that \mathcal{T}_X is a quotient of $\hat{\mathcal{T}}_X$ and if a vector bundle is globally generated then every quotient is globally generated. □

Lemma 3.4. *We have*

$$\dim H^0(\mathbb{P}^1, c^* \hat{\mathcal{T}}_X \otimes \mathcal{O}_{\mathbb{P}^1}(-1 - \varrho)) \geq e(n - d) - \varrho(n - 1)$$

with equality if and only if c is strongly ϱ -free.

Proof. Because \mathcal{I}_X is the kernel of the map $df : \mathcal{I}_{\mathbb{P}^{n-1}} \rightarrow \mathcal{O}_{\mathbb{P}^{n-1}}(d)$, $\hat{\mathcal{I}}_X$ is the kernel of a map $\mathcal{O}_{\mathbb{P}^{n-1}}(1)^n \rightarrow \mathcal{O}_{\mathbb{P}^{n-1}}(d)$ and hence has degree $n - d$. Thus $c^* \hat{\mathcal{I}}_X$ has degree $e(n - d)$. Because it has rank $n - 1$, its tensor product with $\mathcal{O}_{\mathbb{P}^1}(-1 - \varrho)$ has degree $e(n - d) - \varrho(n - 1) - (n - 1)$. Hence by Riemann–Roch, the dimension of its space of global sections is

$$\dim H^0(\mathbb{P}^1, c^* \hat{\mathcal{I}}_X \otimes \mathcal{O}_{\mathbb{P}^1}(-1 - \varrho)) = e(n - d) - \varrho(n - 1) + \dim H^1(\mathbb{P}^1, c^* \hat{\mathcal{I}}_X \otimes \mathcal{O}_{\mathbb{P}^1}(-1 - \varrho)).$$

It now suffices to show that $H^1(\mathbb{P}^1, c^* \hat{\mathcal{I}}_X \otimes \mathcal{O}_{\mathbb{P}^1}(-1 - \varrho))$ vanishes if and only if $c^* \hat{\mathcal{I}}_X \otimes \mathcal{O}_{\mathbb{P}^1}(-\varrho)$ is globally generated. We can assume that

$$c^* \hat{\mathcal{I}}_X = \bigoplus_{i=1}^{n-1} \mathcal{O}_{\mathbb{P}^1}(k_i).$$

Then $H^1(\mathbb{P}^1, c^* \hat{\mathcal{I}}_X \otimes \mathcal{O}_{\mathbb{P}^1}(-1 - \varrho)) = 0$ if and only if $k_i - 1 - \varrho \geq -1$ for all i , which happens if and only if $k_i - \varrho \geq 0$ for all i , which occurs if and only if $c^* \hat{\mathcal{I}}_X \otimes \mathcal{O}_{\mathbb{P}^1}(-\varrho)$ is globally generated. \square

Vector notation such as \mathbf{g} or \mathbf{h} will denote n -tuples of polynomials in T . Let \mathbf{g} be an n -tuple of polynomials in T of degree at most e , at least one of degree e , with no common zero, and such that $f(\mathbf{g}) = 0$. These conditions ensure that $(g_1 : \dots : g_n)$ defines a degree e map $c : \mathbb{P}^1 \rightarrow X$.

Lemma 3.5. $H^0(\mathbb{P}^1, c^* \hat{\mathcal{I}}_X \otimes \mathcal{O}_{\mathbb{P}^1}(-1 - \varrho))$ is isomorphic to the space of n -tuples \mathbf{h} of polynomials in T of degree $\leq e - 1 - \varrho$, such that $\nabla f(\mathbf{g}) \cdot \mathbf{h} = 0$.

Proof. In this proof it will be convenient to set $\mathcal{B} = c^* \hat{\mathcal{I}}_X \otimes \mathcal{O}_{\mathbb{P}^1}(-1 - \varrho)$. We have an exact sequence $0 \rightarrow \hat{\mathcal{I}}_X \rightarrow \mathcal{O}_{\mathbb{P}^{n-1}}(1)^n \rightarrow \mathcal{O}_{\mathbb{P}^{n-1}}(d) \rightarrow 0$, with the last map given by multiplication by the gradient of f . Thus we obtain an exact sequence

$$0 \rightarrow \mathcal{B} \rightarrow c^* \mathcal{O}_{\mathbb{P}^{n-1}}(1)^n \otimes \mathcal{O}_{\mathbb{P}^1}(-1 - \varrho) \rightarrow c^* \mathcal{O}_{\mathbb{P}^{n-1}}(d) \otimes \mathcal{O}_{\mathbb{P}^1}(-1 - \varrho) \rightarrow 0$$

which simplifies to

$$0 \rightarrow \mathcal{B} \rightarrow \mathcal{O}_{\mathbb{P}^1}(e - 1 - \varrho)^n \rightarrow \mathcal{O}_{\mathbb{P}^1}(de - 1 - \varrho) \rightarrow 0,$$

because c has degree e . Applying the cohomology long exact sequence, we see that $H^0(\mathbb{P}^1, \mathcal{B})$ is the kernel of the natural map

$$H^0(\mathbb{P}^1, \mathcal{O}_{\mathbb{P}^1}(e - 1 - \varrho)^n) \rightarrow H^0(\mathbb{P}^1, \mathcal{O}_{\mathbb{P}^1}(de - 1 - \varrho)),$$

given by multiplication by the gradient of f . Since $H^0(\mathbb{P}^1, \mathcal{O}_{\mathbb{P}^1}(e - 1 - \varrho)^n) = H^0(\mathbb{P}^1, \mathcal{O}_{\mathbb{P}^1}(e - 1 - \varrho))^n$ is the space of n -tuples of polynomials of degree at most $e - 1 - \varrho$, this is exactly the stated space. \square

We now assume $K = \mathbb{F}_q$ is a finite field. Thus $f \in \mathbb{F}_q[x_1, \dots, x_n]$ is a nonsingular form of degree $d \geq 3$. We assume throughout that $\text{char}(\mathbb{F}_q) > d$.

Definition 3.6. Let $N(q, e, f)$ be the number of tuples of n polynomials g_1, \dots, g_n over \mathbb{F}_q , of degree at most e , at least one of degree exactly e , with no common zero, such that $f(g_1, \dots, g_n) = 0$.

Definition 3.7. For each integer ϱ , let $N_\varrho(q, e, f)$ be the number of pairs of a tuple of polynomials g_1, \dots, g_n over \mathbb{F}_q , of degree at most e , at least one of degree exactly e , with no common zero and a tuple of polynomials h_1, \dots, h_n over \mathbb{F}_q , of degree at most $e - 1 - \varrho$, such that (1-3) holds.

Proposition 3.8. (1) *The number of \mathbb{F}_q -points on $\mathcal{M}_{0,0}(X, e)$ is*

$$\frac{N(q, e, f)}{(q - 1)(q^3 - q)}.$$

(2) *The number of \mathbb{F}_q -points on Z_ϱ is at most*

$$\frac{N_\varrho(q, e, f)q^{\varrho(n-1)-e(n-d)} - N(q, e, f)}{(q - 1)^2(q^3 - q)}.$$

Proof. Each point of $\mathcal{M}_{0,0}(X, e)$ corresponds to $|\mathrm{PGL}_2(\mathbb{F}_q)| = q^3 - q$ distinct maps $\mathbb{P}^1 \rightarrow X$. Thus in (1) we will count the number of maps $\mathbb{P}^1 \rightarrow X$, and in (2) we will count the number of maps $\mathbb{P}^1 \rightarrow X$ that are not ϱ -free, and in each case then divide by $q^3 - q$.

For (1), it is sufficient to note that for any such tuple \mathbf{g} , $(g_1 : \dots : g_n)$ are the projective coordinates of a degree e map $\mathbb{P}^1 \rightarrow X$. All such maps arise this way, and two tuples define the same map if and only if one is the multiple of the other by a nonzero scalar.

For (2), it follows from Lemma 3.3 that it suffices to consider the space of degree e maps $c : \mathbb{P}^1 \rightarrow X$ that are not strongly ϱ -free. Note that $N_\varrho(q, e, f)$ is the sum over tuples of polynomials (g_1, \dots, g_n) , defining maps c , of q raised to the dimension of the vector space of possible h_1, \dots, h_n . By Lemma 3.5 this exponent is

$$\dim H^0(\mathbb{P}^1, c^* \hat{\mathcal{F}}_X \otimes \mathcal{O}_{\mathbb{P}^1}(-1 - \varrho)).$$

By Lemma 3.4, q to the power of this dimension is equal to $q^{e(n-d)-\varrho(n-1)}$ if c is strongly ϱ -free and is at least $q^{e(n-d)-\varrho(n-1)+1}$ otherwise. Hence

$$N_\varrho(q, e, f)q^{\varrho(n-1)-e(n-d)} \geq \sum_{\substack{\mathbf{g} \in \mathbb{F}_q[T]^n \\ |\mathbf{g}|=e \\ c \text{ not strongly } \varrho\text{-free}}} q + \sum_{\substack{\mathbf{g} \in \mathbb{F}_q[T]^n \\ |\mathbf{g}|=e \\ c \text{ strongly } \varrho\text{-free}}} 1 = N(q, e, f) + (q - 1) \sum_{\substack{\mathbf{g} \in \mathbb{F}_q[T]^n \\ |\mathbf{g}|=e \\ c \text{ not strongly } \varrho\text{-free}}} 1.$$

The proposition follows on noting that there are $(q - 1)$ tuples \mathbf{g} for each map $c : \mathbb{P}^1 \rightarrow X$. □

4. The circle method: identification of major arcs

For $e \geq 1$ we have

$$N(q, e, f) = \#\{\mathbf{g} \in \mathbb{F}_q[T]^n : |\mathbf{g}| = q^e, f(\mathbf{g}) = 0, \gcd(g_1, \dots, g_n) = 1\},$$

where $\mathbf{g} = (g_1, \dots, g_n)$ and $|\mathbf{g}| = \max_{1 \leq i \leq n} |g_i|$. In particular only nonzero vectors \mathbf{g} occur. Similarly, we may write

$$N_\varrho(q, e, f) = \sum_{\substack{\mathbf{g} \in \mathbb{F}_q[T]^n \\ |\mathbf{g}|=q^e \\ f(\mathbf{g})=0 \\ \gcd(g_1, \dots, g_n)=1}} \sum_{\substack{\mathbf{h} \in \mathbb{F}_q[T]^n \\ |\mathbf{h}| < q^{e-\varrho} \\ \mathbf{h} \cdot \nabla f(\mathbf{g})=0}} 1,$$

where once again we note that only nonzero vectors \mathbf{g} occur. We may use the function field analogue of the Möbius function $\mu : \mathbb{F}_q[T] \rightarrow \{0, \pm 1\}$ to detect the coprimality condition $\gcd(g_1, \dots, g_n) = 1$. This gives

$$N_\varrho(q, e, f) = \sum_{\substack{k \in \mathbb{F}_q[T] \\ k \text{ monic}}} \mu(k) \sum_{\substack{\mathbf{g} \in \mathbb{F}_q[T]^n \\ 0 < |\mathbf{g}|=q^e/|k| \\ f(\mathbf{g})=0}} \sum_{\substack{\mathbf{h} \in \mathbb{F}_q[T]^n \\ |\mathbf{h}| < q^{e-\varrho} \\ \mathbf{h} \cdot \nabla f(\mathbf{g})=0}} 1 = \sum_{j \geq 0} \sum_{\substack{k \in \mathbb{F}_q[T] \\ |k|=q^j \\ k \text{ monic}}} \mu(k) \sum_{\substack{\mathbf{g} \in \mathbb{F}_q[T]^n \\ 0 < |\mathbf{g}|=q^{e-j} \\ f(\mathbf{g})=0}} \sum_{\substack{\mathbf{h} \in \mathbb{F}_q[T]^n \\ |\mathbf{h}| < q^{e-\varrho} \\ \mathbf{h} \cdot \nabla f(\mathbf{g})=0}} 1.$$

In view of the elementary identity

$$\sum_{\substack{k \in \mathbb{F}_q[T] \\ |k|=q^j \\ k \text{ monic}}} \mu(k) = \begin{cases} 1 & \text{if } j = 0, \\ -q & \text{if } j = 1, \\ 0 & \text{if } j > 1, \end{cases} \tag{4-1}$$

it readily follows that

$$N_\varrho(q, e, f) = \sum_{j \geq 0} c_j N(e - j + 1, e - \varrho),$$

where

$$c_j = \begin{cases} 1 & \text{if } j = 0, \\ -(q + 1) & \text{if } j = 1, \\ q & \text{if } j = 2, \\ 0 & \text{if } j > 2 \end{cases} \tag{4-2}$$

and

$$N(u, v) = \sum_{\substack{\mathbf{g} \in \mathbb{F}_q[T]^n \\ 0 < |\mathbf{g}| < q^u \\ f(\mathbf{g})=0}} \sum_{\substack{\mathbf{h} \in \mathbb{F}_q[T]^n \\ |\mathbf{h}| < q^v \\ \mathbf{h} \cdot \nabla f(\mathbf{g})=0}} 1,$$

for any integers $u, v \geq 1$.

We have

$$\sum_{\substack{\mathbf{h} \in \mathbb{F}_q[T]^n \\ |\mathbf{h}| < q^{e-\varrho} \\ \mathbf{h} \cdot \nabla f(\mathbf{g})=0}} 1 = \int_{\mathbb{T}} S(\beta) d\beta,$$

where

$$S(\beta) = \sum_{\substack{\mathbf{h} \in \mathbb{F}_q[T]^n \\ |\mathbf{h}| < q^{e-\varrho}}} \psi(\beta \mathbf{h} \cdot \nabla f(\mathbf{g})).$$

Here the integral is over the space \mathbb{T} of formal Laurent series in T^{-1} of degree less than 0, against the Haar measure with total mass 1, and ψ is the additive character of $\mathbb{F}_q((T^{-1}))$ that sends a formal Laurent series in T^{-1} to a fixed nontrivial additive character of \mathbb{F}_q applied to the coefficient of T^{-1} . With this notation we now have

$$N_\varrho(q, e, f) = \sum_{j \geq 0} c_j \sum_{\substack{\mathbf{g} \in \mathbb{F}_q[T]^n \\ 0 < |\mathbf{g}| < q^{e-j+1} \\ f(\mathbf{g})=0}} \int_{\mathbb{T}} S(\beta) d\beta. \tag{4-3}$$

Our plan will be to define a set of major arcs whose total contribution to $q^{\varrho(n-1)-e(n-d)} N_\varrho(q, e, f)$ is matched by $N(q, e, f)$. We note that the sum over \mathbf{g} is empty unless $e \geq j$, so we will be able to assume this whenever dealing with this sum.

In what follows we shall frequently make use of the basic orthogonality property

$$\sum_{\substack{b \in \mathbb{F}_q[T] \\ |b| < q^B}} \psi(\gamma b) = \begin{cases} q^B & \text{if } \|\gamma\| < q^{-B}, \\ 0 & \text{otherwise,} \end{cases} \tag{4-4}$$

which is valid for any integer $B \geq 0$ and any $\gamma \in \mathbb{F}_q((T^{-1}))$. Here we recall that $\|\gamma\| = |\sum_{i \leq -1} b_i T^i|$ for any $\gamma = \sum_{i \leq N} b_i T^i \in \mathbb{F}_q((T^{-1}))$.

Let $\mathbf{g} \in \mathbb{F}_q[T]^n$ be a nonzero vector such that $f(\mathbf{g}) = 0$. The next result is the first step towards defining the relevant set of major arcs for our problem.

Lemma 4.1. *Suppose that $\beta = a/r + \theta$ for coprime polynomials $a, r \in \mathbb{F}_q[T]$ such that $|a| < |r| \leq q^{e-\varrho}$. Assume that $|r\theta| < q^{-(d-1)(e-j)}$. Then*

$$S(\beta) = \begin{cases} q^{n(e-\varrho)} & \text{if } r \mid \gcd(g_1, \dots, g_n)^{d-1} \text{ and } |\theta| < q^{e-e}/|\mathbf{g}|^{d-1}, \\ 0 & \text{otherwise.} \end{cases}$$

Proof. We break the sum into residue classes modulo r , by writing $\mathbf{h} = \mathbf{u} + r\mathbf{v}$ for $|\mathbf{u}| < |r|$ and $|\mathbf{v}| < q^{e-\varrho}/|r|$. Then

$$S(\beta) = \sum_{\substack{\mathbf{u} \in \mathbb{F}_q[T]^n \\ |\mathbf{u}| < |r|}} \psi(\beta \mathbf{u} \cdot \nabla f(\mathbf{g})) \sum_{\substack{\mathbf{v} \in \mathbb{F}_q[T]^n \\ |\mathbf{v}| < q^{e-\varrho}/|r|}} \psi(r\theta \mathbf{v} \cdot \nabla f(\mathbf{g}))$$

Since $|r\theta| < q^{-(d-1)(e-j)}$ we have $|r\theta \nabla f(\mathbf{g})| \leq |r\theta| q^{(d-1)(e-j)} < 1$. Thus $\|r\theta \nabla f(\mathbf{g})\| = |r\theta \nabla f(\mathbf{g})|$ and it follows from (4-4) that

$$\sum_{\substack{\mathbf{v} \in \mathbb{F}_q[T]^n \\ |\mathbf{v}| < q^{e-\varrho}/|r|}} \psi(r\theta \mathbf{v} \cdot \nabla f(\mathbf{g})) = \begin{cases} |r|^{-n} q^{n(e-\varrho)} & \text{if } |\theta \nabla f(\mathbf{g})| < q^{e-e}, \\ 0 & \text{otherwise.} \end{cases}$$

We claim that $|\nabla f(\mathbf{g})| = |\mathbf{g}|^{d-1}$. To see this suppose that $|\mathbf{g}| = q^m$ for a nonnegative integer m and let $\mathbf{g}^* \in \mathbb{F}_q^n$ be the (nonzero) leading coefficient of \mathbf{g} . In particular $f(\mathbf{g}^*) = 0$ since $f(\mathbf{g}) = 0$. Since f has degree d it follows that the coefficient of $T^{m(d-1)}$ in $\nabla f(\mathbf{g})$ is $\nabla f(\mathbf{g}^*) \neq \mathbf{0}$, since f is nonsingular.

Our argument so far shows that

$$S(\beta) = \begin{cases} |r|^{-n} q^{n(e-\varrho)} T(\beta) & \text{if } |\theta| < q^{\varrho-e}/|\mathbf{g}|^{d-1}, \\ 0 & \text{otherwise,} \end{cases}$$

where

$$T(\beta) = \sum_{\substack{\mathbf{u} \in \mathbb{F}_q[T]^n \\ |\mathbf{u}| < |r|}} \psi(\beta \mathbf{u} \cdot \nabla f(\mathbf{g})).$$

When $|\theta| < q^{\varrho-e}/|\mathbf{g}|^{d-1}$ it follows that

$$|\theta \mathbf{u} \cdot \nabla f(\mathbf{g})| \leq q^{-1} |\theta r \nabla f(\mathbf{g})| \leq q^{-2+\varrho-e} |r| \leq q^{-2},$$

since $|r| \leq q^{e-\varrho}$. Hence, since a and r are coprime, we deduce that

$$T(\beta) = \sum_{\substack{\mathbf{u} \in \mathbb{F}_q[T]^n \\ |\mathbf{u}| < |r|}} \psi\left(\frac{a\mathbf{u} \cdot \nabla f(\mathbf{g})}{r}\right) = \begin{cases} |r|^n & \text{if } r \mid \nabla f(\mathbf{g}), \\ 0 & \text{otherwise,} \end{cases}$$

Since f is a nonsingular form, the statement of the lemma follows on noting that $r \mid \nabla f(\mathbf{g})$ if and only if $r \mid \gcd(g_1, \dots, g_n)^{d-1}$. □

Lemma 4.2. *Suppose that $e \geq \varrho$ and*

$$\frac{a_1}{r_1} + \theta_1 = \frac{a_2}{r_2} + \theta_2,$$

with $r_1, r_2 \mid \gcd(g_1, \dots, g_n)^{d-1}$ and $|\theta_1|, |\theta_2| < q^{\varrho-e}/|\mathbf{g}|^{d-1}$. Then in fact $\frac{a_1}{r_1} = \frac{a_2}{r_2}$ (and so $\theta_1 = \theta_2$).

Proof. By clearing denominators, we may assume $r_1 = r_2 = \gcd(g_1, \dots, g_n)^{d-1}$. Then $a_1 - a_2 = \gcd(g_1, \dots, g_n)^{d-1}(\theta_2 - \theta_1)$, so that

$$|a_1 - a_2| < q^{\varrho-e} \frac{\gcd(g_1, \dots, g_n)^{d-1}}{|\mathbf{g}|^{d-1}} \leq q^{\varrho-e} \leq 1.$$

This implies that $a_1 = a_2$, as required. □

We take as major arcs the union

$$\mathfrak{N}_j = \bigcup_{\substack{r \in \mathbb{F}_q[T] \text{ monic} \\ |r| \leq q^{e-\varrho}}} \bigcup_{\substack{|a| < |r| \\ \gcd(a,r)=1}} \{\beta \in \mathbb{F}_q((T^{-1})) : |r\beta - a| < q^{-(d-1)(e-j)}\}, \tag{4-5}$$

for $j \geq 0$. It follows from [Lemma 4.1](#) that $S(\beta)$ is nonzero for $\beta \in \mathfrak{N}_j$ if and only if there is some pair $(a/r, \theta)$ such that $\beta = a/r + \theta$ and all the conditions

$$|r| \leq q^{e-\varrho}, \quad |\theta| < |r|^{-1} q^{-(d-1)(e-j)}, \quad |a| < |r|, \quad \gcd(a, r) = 1,$$

and

$$r \mid \gcd(g_1, \dots, g_n)^{d-1}, \quad |\theta| < q^{\varrho-e}/|\mathbf{g}|^{d-1}$$

are satisfied. By [Lemma 4.2](#), pairs satisfying these conditions (or even the last three conditions) are unique. Hence we can rewrite the integral over the major arcs as

$$\begin{aligned} \int_{\mathfrak{M}_j} S(\beta) d\beta &= q^{n(e-\varrho)} \sum_{\substack{|r| \leq q^{e-\varrho} \\ r \text{ monic} \\ r \mid \gcd(g_1, \dots, g_n)^{d-1}}} \sum_{\substack{|a| < |r| \\ \gcd(a,r)=1}} \int_{|\theta| < \min\{q^{e-\varrho}/|\mathbf{g}|^{d-1}, |r|^{-1}q^{-(d-1)(e-j)}\}} d\theta \\ &= q^{n(e-\varrho)} \sum_{\substack{|r| \leq q^{e-\varrho} \\ r \text{ monic} \\ r \mid \gcd(g_1, \dots, g_n)^{d-1}}} \varphi(r) \int_{|\theta| < \min\{q^{e-\varrho}/|\mathbf{g}|^{d-1}, |r|^{-1}q^{-(d-1)(e-j)}\}} d\theta, \end{aligned}$$

for any nonzero vector $\mathbf{g} \in \mathbb{F}_q[T]^n$ such that $f(\mathbf{g}) = 0$, where $\varphi(r)$ is the function field analogue of the Euler totient function. We want to replace the integral over θ by

$$\int_{|\theta| < q^{e-\varrho}/|\mathbf{g}|^{d-1}} d\theta = \frac{q^{e-\varrho}}{|\mathbf{g}|^{d-1}}.$$

The error in doing this is at most this volume multiplied by the indicator function for the inequality

$$|r|^{-1}q^{-(d-1)(e-j)} < q^{e-\varrho}/|\mathbf{g}|^{d-1}.$$

Since $r \mid \gcd(g_1, \dots, g_n)^{d-1}$ this inequality implies that

$$q^{j+D+1}|\mathbf{g}| \leq |\gcd(g_1, \dots, g_n)|q^e, \tag{4-6}$$

where

$$D = \left\lfloor \frac{e-\varrho}{d-1} \right\rfloor. \tag{4-7}$$

At this point we observe that

$$\sum_{\substack{r \in \mathbb{F}_q[T] \text{ monic} \\ r \mid \gcd(g_1, \dots, g_n)^{d-1}}} \varphi(r) = |\gcd(g_1, \dots, g_n)|^{d-1},$$

since $\mathbf{g} \neq \mathbf{0}$. Note that when $r \mid \gcd(g_1, \dots, g_n)^{d-1}$ and $|r| > q^{e-\varrho}$ we must have

$$|\gcd(g_1, \dots, g_n)| \geq q^{D+1}, \tag{4-8}$$

with D as above. Putting everything together it follows that

$$\int_{\mathfrak{M}_j} S(\beta) d\beta = \frac{q^{(n-1)(e-\varrho)}|\gcd(g_1, \dots, g_n)|^{d-1}}{|\mathbf{g}|^{d-1}} (1 + \epsilon_j \mathbf{1}_j(\mathbf{g})) \tag{4-9}$$

for $\epsilon_j \in [-1, 1]$, where

$$\mathbf{1}_j(\mathbf{g}) = \begin{cases} 1 & \text{if (4-6) or (4-8) hold,} \\ 0 & \text{otherwise.} \end{cases}$$

Let $N_\varrho^{\text{major}}(q, e, f)$ denote the contribution to the right-hand side of (4-3) from (4-9) for each j . We now see that

$$N_\varrho^{\text{major}}(q, e, f) = q^{(n-1)(e-\varrho)} \sum_{j \geq 0} c_j \sum_{\substack{\mathbf{g} \in \mathbb{F}_q[T]^n \\ 0 < |\mathbf{g}| < q^{e-j+1} \\ f(\mathbf{g})=0}} \frac{|\text{gcd}(g_1, \dots, g_n)|^{d-1}}{|\mathbf{g}|^{d-1}} (1 + \epsilon_j \mathbf{1}_j(\mathbf{g})).$$

On noting that $(n-1)(e-\varrho) - e(d-1) = e(n-d) - \varrho(n-1)$, the main term is seen to be

$$q^{e(n-d)-\varrho(n-1)} (\tilde{N}(e) - q^d \tilde{N}(e-1)),$$

where for $u \geq 0$ we set

$$\tilde{N}(u) = \sum_{\substack{\mathbf{g} \in \mathbb{F}_q[T]^n \\ |\mathbf{g}|=q^u \\ f(\mathbf{g})=0}} |\text{gcd}(g_1, \dots, g_n)|^{d-1} = \sum_{\substack{k \in \mathbb{F}_q[T] \\ |k| \leq q^u \\ k \text{ monic}}} |k|^{d-1} N(q, u - \text{deg}(k), f) = \sum_{\ell=0}^u q^{d\ell} N(q, u - \ell, f),$$

in the notation of Definition 3.6. Hence

$$\tilde{N}(e) - q^d \tilde{N}(e-1) = \sum_{\ell=0}^e q^{d\ell} N(q, e - \ell, f) - \sum_{\ell=0}^{e-1} q^{d(\ell+1)} N(q, e - 1 - \ell, f) = N(q, e, f).$$

Remark 4.3. The cancellation here is not miraculous. The terms corresponding to \mathbf{g} with $|\mathbf{g}| < q^e$ or $|\text{gcd}(g_1, \dots, g_n)| > 1$ disappear precisely because c_j were the coefficients defined in (4-2) to sieve out these terms in the first place.

Turning to the error term we can combine (4-6) and (4-8) to deduce that

$$\text{gcd}(g_1, \dots, g_n) \geq q^{D+1} \min(1, q^{j-e} |\mathbf{g}|) = q^{D+1+j-e} |\mathbf{g}|$$

whenever $\mathbf{1}_j(\mathbf{g}) = 1$. Hence

$$N_\varrho^{\text{major}}(q, e, f) - q^{e(n-d)-\varrho(n-1)} N(q, e, f) \leq q^{(n-1)(e-\varrho)} \sum_{j \geq 0} |c_j| E_j,$$

where

$$\begin{aligned} E_j &= \sum_{0 \leq u \leq e-j} \sum_{\substack{k \in \mathbb{F}_q[T] \text{ monic} \\ |k| \geq q^{D+1+j-e+u}}} \frac{|k|^{d-1}}{q^{u(d-1)}} \#\{\mathbf{g} \in \mathbb{F}_q[T]^n : |\mathbf{g}| = q^u, f(\mathbf{g}) = 0, k = \text{gcd}(g_1, \dots, g_n)\} \\ &= \sum_{0 \leq u \leq e-j} \sum_{\ell \geq D+1+j-e+u} \frac{q^\ell}{q^{(u-\ell)(d-1)}} N(q, u - \ell, f). \end{aligned}$$

Invoking [Browning and Vishe 2015, Lemma 2.8], we deduce that $N(q, e, f) = O_f(q^{(e+1)(n-1)})$ for any $n \geq 3$, where the implied constant depends at most on f . Hence, since we may clearly assume that

$n > d + 1$, it follows that

$$\begin{aligned}
 E_j &\ll_f \sum_{0 \leq u \leq e-j} q^{u(n-d)+n-1} \sum_{\ell \geq D+1+j-e+u} q^{-\ell(n-d-1)} \\
 &\ll_f q^{-(D+1)(n-d-1)} \sum_{0 \leq u \leq e-j} \frac{q^{u(n-d)+n-1}}{q^{(u-e+j)(n-d-1)}} \\
 &\ll_f q^{(e-j)(n-d)+n-1-(D+1)(n-d-1)}.
 \end{aligned} \tag{4-10}$$

The implied constant in this estimate depends only on f and not on q . Thus

$$q^{(n-1)(e-\varrho)} \sum_{j \geq 0} |c_j| E_j \ll_f q^{2e(n-d)-\varrho(n-1)+de-e+n-1-(D+1)(n-d-1)}.$$

Putting everything together, we may conclude as follows.

Lemma 4.4. *Let $\varrho \in \mathbb{Z}$ and assume that $e \geq \varrho$. Then*

$$N_\varrho^{\text{major}}(q, e, f) = q^{e(n-d)-\varrho(n-1)}(N(q, e, f) + O_f(q^{(e+1)(n-1)-(D+1)(n-d-1)})),$$

where D is given by (4-7).

5. The circle method: minor arcs

It remains to study the quantity

$$N_\varrho^{\text{minor}}(q, e, f) = \sum_{j \geq 0} c_j \sum_{\substack{\mathbf{g} \in \mathbb{F}_q[T]^n \\ 0 < |\mathbf{g}| < q^{e-j+1} \\ f(\mathbf{g})=0}} \int_{\mathfrak{n}_j} S(\beta) d\beta, \tag{5-1}$$

where \mathfrak{n}_j is the complement in $\mathbb{T} = \{\beta \in \mathbb{F}_q((T^{-1})) : |\beta| < 1\}$ of the major arcs \mathfrak{M}_j that we defined in (4-5). Indeed, in view of Proposition 3.8(2), the following result is now a direct consequence of (4-3) and Lemma 4.4.

Lemma 5.1. *Assume that $d \geq 3$ and $e \geq \varrho$. Then*

$$\#Z_\varrho(\mathbb{F}_q) \leq \frac{q^{\varrho(n-1)-e(n-d)}}{(q-1)^2(q^3-q)} N_\varrho^{\text{minor}}(q, e, f) + O_f(q^{(e+1)(n-1)-5-(D+1)(n-d-1)}),$$

where D is given by (4-7).

We have

$$\sum_{\substack{\mathbf{g} \in \mathbb{F}_q[T]^n \\ 0 < |\mathbf{g}| < q^{e-j+1} \\ f(\mathbf{g})=0}} \int_{\mathfrak{n}_j} S(\beta) d\beta = \int_{\mathbb{T}} \int_{\mathfrak{n}_j} (S(\alpha, \beta) - q^{n(e-\varrho)}) d\alpha d\beta, \tag{5-2}$$

where

$$S(\alpha, \beta) = \sum_{\substack{\mathbf{g} \in \mathbb{F}_q[T]^n \\ |\mathbf{g}| < q^{e-j+1}}} \sum_{\substack{\mathbf{h} \in \mathbb{F}_q[T]^n \\ |\mathbf{h}| < q^{e-\varrho}}} \psi(\alpha f(\mathbf{g}) + \beta \mathbf{h} \cdot \nabla f(\mathbf{g})). \tag{5-3}$$

Viewed as polynomials in the $2n$ variables (\mathbf{g}, \mathbf{h}) the pair of polynomials $f(\mathbf{g})$ and $\mathbf{h} \cdot \nabla f(\mathbf{g})$ are homogeneous of degree d . The obvious thing to do at this point is to apply Weyl differencing $d - 1$ times in the spirit of Birch. This requires one to work with a simultaneous Diophantine approximation of α and β , which is somewhat wasteful. It bears fruit provided that

$$2n - \dim V^* > 3(d - 1)2^d,$$

where V^* is the (affine) ‘‘Birch singular locus’’. In this setting V^* is the locus of $(\mathbf{g}, \mathbf{h}) \in \mathbb{A}^{2n}$ such that the pair of vectors $(\nabla f(\mathbf{g}), \mathbf{0})$ and $(\mathbf{h} \cdot \nabla^2 f(\mathbf{g}), \nabla f(\mathbf{g}))$ are proportional. Since f is nonsingular, it follows that V^* is the set of $(\mathbf{g}, \mathbf{h}) \in \mathbb{A}^{2n}$ such that $\mathbf{g} = \mathbf{0}$, so that $\dim V^* = n$. In this way we see that the standard approach would require $n > 3(d - 1)2^d$ variables overall, although there are additional difficulties associated to having lopsided boxes. In our work we shall exploit the special shape of our polynomials in such a way that our estimates are only sensitive to the Diophantine approximation properties of α or β independently. This allows us to handle half the number of variables when dealing with the sum $S(\alpha, \beta)$.

In what follows it will be convenient to define the monomials

$$P_0(T) = T^{e-j}, \quad P(T) = T^{e-j+1} \quad \text{and} \quad Q(T) = T^{e-\varrho}.$$

Let

$$\mathfrak{M}(J) = \bigcup_{\substack{r \in \mathbb{F}_q[T] \text{ monic} \\ |r| \leq q^J}} \bigcup_{\substack{absa < |r| \\ \gcd(a,r)=1}} \{ \alpha \in \mathbb{F}_q((T^{-1})) : |r\alpha - a| < q^J |P_0|^{-d} \}, \tag{5-4}$$

for any integer J . Note that $\mathfrak{M}(-1) = \emptyset$. Let

$$M = \left\lceil \frac{d(e-j)}{2} \right\rceil. \tag{5-5}$$

According to the function field version of Dirichlet’s approximation theorem any element of \mathbb{T} has a representation $a/r + \theta$ with $absa < |r| \leq q^M$ and $|r\theta| < q^{-M}$. Hence we can cover \mathbb{T} by a union of arcs $\mathfrak{M}(J + 1) \setminus \mathfrak{M}(J)$ for integers J such that $-1 \leq J \leq M - 1$.

Next, let

$$\mathfrak{N}(K) = \bigcup_{\substack{r \in \mathbb{F}_q[T] \text{ monic} \\ |r| \leq q^K}} \bigcup_{\substack{absa < |r| \\ \gcd(a,r)=1}} \left\{ \beta \in \mathbb{F}_q((T^{-1})) : |r\beta - a| < \frac{q^K}{|P_0|^{d-1} |Q|} \right\}, \tag{5-6}$$

for any integer K . We note that $\mathfrak{N}(e - \varrho) = \mathfrak{N}_j$, in the notation of (4-5). Let

$$N = \left\lceil \frac{(e-j)(d-1) + e - \varrho}{2} \right\rceil. \tag{5-7}$$

It now follows from Dirichlet’s approximation theorem that the minor arcs n_j can be covered by the union of arcs $\mathfrak{N}(K + 1) \setminus \mathfrak{N}(K)$ for integers K such that $e - \varrho \leq K \leq N - 1$.

Observe in particular that if any minor arcs exist then $e - \varrho < N$ so

$$(d - 1)(e - j) > e - \varrho. \tag{5-8}$$

We may thus assume (5-8) when dealing with the minor arcs. Keeping the assumptions $d \geq 3$ and $e \geq \varrho$, we see in particular that

$$|P|, |Q| \geq 1.$$

Our plan is to produce two estimates for $S(\alpha, \beta)$: one for when α belongs to $\mathfrak{M}(J + 1) \setminus \mathfrak{M}(J)$ and one for when β belongs to $\mathfrak{N}(K + 1) \setminus \mathfrak{N}(K)$. Before proceeding further we note that

$$\text{meas}(\mathfrak{M}(J)) \leq q^{2J} |P_0|^{-d} \tag{5-9}$$

and

$$\text{meas}(\mathfrak{N}(K)) \leq q^{2K} |P_0|^{-d+1} |Q|^{-1}, \tag{5-10}$$

for any integers $J, K \geq 0$.

Suppose that

$$f(\mathbf{x}) = \sum_{i_1, \dots, i_d=1}^n c_{i_1, \dots, i_d} x_{i_1} \dots x_{i_d},$$

with symmetric coefficients $c_{i_1, \dots, i_d} \in \mathbb{F}_q$. Associated to f are the multilinear forms

$$\Psi_i(\mathbf{x}^{(1)}, \dots, \mathbf{x}^{(d-1)}) = d! \sum_{i_1, \dots, i_{d-1}=1}^n c_{i_1, \dots, i_{d-1}, i} x_{i_1}^{(1)} \dots x_{i_{d-1}}^{(d-1)}, \tag{5-11}$$

for $1 \leq i \leq n$. Our first estimate for $S(\alpha, \beta)$ involves summing trivially over \mathbf{h} and then applying Weyl differencing $d - 1$ times to the sum over \mathbf{g} . This eliminates the effect of the lower degree term $\beta \mathbf{h} \cdot \nabla f(\mathbf{g})$ and leads one to a family of linear exponential sums with phase vectors $(\alpha \Psi_1(\mathbf{g}), \dots, \alpha \Psi_n(\mathbf{g}))$, for $\mathbf{g} = (\mathbf{g}_1, \dots, \mathbf{g}_{d-1}) \in \mathbb{F}_q[T]^{(d-1)n}$. This approach closely parallels [Browning and Vishe 2017].

An alternative estimate for $S(\alpha, \beta)$ is obtained by applying Weyl differencing $d - 2$ times to the sum over \mathbf{g} . After a further application of Cauchy–Schwarz one then brings the \mathbf{h} -sum inside, giving a family of linear exponential sums with phase vectors $(\beta \Psi_1(\mathbf{g}), \dots, \beta \Psi_n(\mathbf{g}))$, for $\mathbf{g} \in \mathbb{F}_q[T]^{(d-1)n}$. This brings the Diophantine properties of β into play but extra difficulties arise from the fact that P and Q need not have the same degree.

5A. Geometry-of-numbers redux. We shall need to begin by revisiting a function field lattice point counting result that played a key role in [Browning and Vishe 2017]. A lattice in $\mathbb{F}_q((T^{-1}))^N$ is a set of points of the form $\mathbf{x} = \Lambda \mathbf{u}$ where Λ is an $N \times N$ invertible matrix over $\mathbb{F}_q((T^{-1}))$ and \mathbf{u} runs over elements of $\mathbb{F}_q[T]^n$. Given a lattice Λ , the adjoint lattice is defined as the lattice associated to the inverse transpose matrix Λ^{-T} .

Remark 5.2. We can view lattices as vector bundles on \mathbb{P}^1 by viewing the matrix Λ as giving gluing data for gluing the trivial vector bundle on \mathbb{A}^1 and the trivial vector bundle on a formal neighborhood of ∞ , using the Beauville–Laszlo theorem. The adjoint lattice corresponds to the dual vector bundle, and the geometry-of-numbers computations in this section could instead be stated in this language.

Bearing our notation in mind we recall a version of the “shrinking lemma” that is proved in [Browning and Sawin 2020b, Lemma 6.4].

Lemma 5.3. *Let γ be a symmetric $n \times n$ matrix with entries in $\mathbb{F}_q((T^{-1}))$. Let $a, c, s \in \mathbb{Z}$ such that $c > 0$ and $s \geq 0$. Let $N_{\gamma,a,c}$ be the number of $\mathbf{x} \in \mathbb{F}_q[T]^n$ such that $|\mathbf{x}| < q^a$ and $\|\gamma\mathbf{x}\| < q^{-c}$. Then*

$$\frac{N_{\gamma,a,c}}{N_{\gamma,a-s,c+s}} \leq q^{ns+n \max(\lfloor (a-c)/2 \rfloor, 0)}.$$

For any $\alpha \in \mathbb{F}_q((T^{-1}))$ and any $r > 0$, we set

$$N(\alpha; r) = \#\{\underline{\mathbf{g}} \in \mathbb{F}_q[T]^{(d-1)n} : |\mathbf{g}_1|, \dots, |\mathbf{g}_{d-1}| < |P|, \|\alpha\Psi_i(\underline{\mathbf{g}})\| < q^{-r} (\forall i \leq n)\}. \quad (5-12)$$

Furthermore, for an integer $s \geq 0$, we put

$$N_s(\alpha; r) = \#\{\underline{\mathbf{g}} \in \mathbb{F}_q[T]^{(d-1)n} : |\mathbf{g}_1|, \dots, |\mathbf{g}_{d-1}| < |P|/q^s, \|\alpha\Psi_i(\underline{\mathbf{g}})\| < q^{-r-(d-1)s} (\forall i \leq n)\}.$$

We can use the shrinking lemma to bound the ratio of these two quantities as follows.

Lemma 5.4. *For $r > 0$ and $s \geq \max(0, e - j + 1 - r)$, we have*

$$\frac{N(\alpha, r)}{N_s(\alpha, r)} \leq q^{(d-1)ns+n \max(0, \lfloor (e-j+1-r)/2 \rfloor)}.$$

Proof. For each $v \in \{0, \dots, d-1\}$, let $N^{(v)}(\alpha, r)$ be the number of vectors $\underline{\mathbf{g}} \in \mathbb{F}_q[T]^{(d-1)n}$ such that

$$|\mathbf{g}_1|, \dots, |\mathbf{g}_v| < |P|/q^s, \quad |\mathbf{g}_{v+1}|, \dots, |\mathbf{g}_{d-1}| < |P| \quad (5-13)$$

and $\|\alpha\Psi_i(\underline{\mathbf{g}})\| < q^{-r-v}$, for $1 \leq i \leq n$. Thus we have $N^{(0)}(\alpha, r) = N(\alpha, r)$ and $N^{(d-1)}(\alpha, r) = N_s(\alpha, r)$.

Fix a choice of $v \in \{1, \dots, d-1\}$ and let $\mathbf{g}_1, \dots, \mathbf{g}_{v-1}, \mathbf{g}_{v+1}, \dots, \mathbf{g}_{d-1} \in \mathbb{F}_q[T]^n$ such that (5-13) holds. We consider the linear forms

$$L_i(\mathbf{g}) = \alpha\Psi_i(\mathbf{g}_1, \dots, \mathbf{g}_{v-1}, \mathbf{g}, \mathbf{g}_{v+1}, \dots, \mathbf{g}_{d-1}),$$

for $1 \leq i \leq n$. These form an $n \times n$ matrix. Because Ψ_i is the dualization in one variable of a symmetric d -linear form, this $n \times n$ matrix is symmetric. The contribution to $N^{(v-1)}(\alpha, r)$ from tuples with the chosen $\mathbf{g}_1, \dots, \mathbf{g}_{v-1}, \mathbf{g}_{v+1}, \dots, \mathbf{g}_{d-1} \in \mathbb{F}_q[T]^n$ is $N_{\gamma, e-j+1, r+(v-1)s}$ while the contribution to $N^{(v)}(\alpha, r)$ from tuples of the same form is $N_{\gamma, e-j+1-s, r+vs}$. Note that $r + (v-1)s \geq r > 0$ for $v \geq 1$ and so Lemma 5.3 is applicable. We deduce that

$$\frac{N^{(v-1)}(\alpha, r)}{N^{(v)}(\alpha, r)} \leq q^{ns+n \max(\lfloor (e-j+1-r-(v-1)s)/2 \rfloor, 0)}$$

for $1 \leq v \leq d-1$.

We take the product of this inequality over all v from 1 to $d - 1$. The first term in the exponent contributes $(d - 1)ns$. The second contributes $n \max(\lfloor (e - j + 1 - r)/2 \rfloor, 0)$ for $v = 1$ and 0 for all other values of v , on assuming that $s \geq e - j + 1 - r$. Thus we get the stated bound. \square

5B. Weyl differencing. Our fundamental tool for estimating $S(\alpha, \beta)$ is Weyl differencing. We recall first that $|P|, |Q| \geq 1$ in this exponential sum. Appealing to [Browning and Vishe 2017, Equation (5.2)] first, Weyl differencing $d - 1$ times gives

$$|S(\alpha, \beta)| \leq |P|^n |Q|^n (|P|^{-(d-1)n} N(\alpha, e - j + 1))^{1/2^{d-1}},$$

in the notation of (5-12). Note that as $N(\alpha, e - j + 1) \geq 1$ and $2^{d-1} \geq (d - 1)$, the right side is $\geq |Q|^n$. Thus we have

$$|S(\alpha, \beta) - q^{n(e-\rho)}| \leq 2|P|^n |Q|^n (|P|^{-(d-1)n} N(\alpha, e - j + 1))^{1/2^{d-1}}, \tag{5-14}$$

We can also obtain an upper bound for $S(\alpha, \beta)$ that only uses information about β . Let us put

$$T(\mathbf{h}) = \sum_{|\mathbf{g}| < |P|} \psi(\alpha f(\mathbf{g}) + \beta \mathbf{h} \cdot \nabla f(\mathbf{g})),$$

so that

$$S(\alpha, \beta) = \sum_{|\mathbf{h}| < |Q|} T(\mathbf{h}),$$

with P, Q are as before. It follows from Cauchy–Schwarz that

$$|S(\alpha, \beta)|^{2^{d-2}} \leq |Q|^{(2^{d-2}-1)n} \sum_{|\mathbf{h}| < |Q|} |T(\mathbf{h})|^{2^{d-2}}. \tag{5-15}$$

After $d - 3$ applications of Weyl differencing we obtain

$$|T(\mathbf{h})|^{2^{d-3}} \leq |P|^{(2^{d-3}-d+2)n} \sum_{\mathbf{g}_1, \dots, \mathbf{g}_{d-3}} \left| \sum_{\mathbf{g}} \psi(D(\mathbf{g})) \right|,$$

where $D(\mathbf{g}) = D_{\mathbf{g}_1, \dots, \mathbf{g}_{d-3}}(\alpha f(\mathbf{g}) + \beta \mathbf{h} \cdot \nabla f(\mathbf{g}))$ and $D_{\mathbf{g}_1, \dots, \mathbf{g}_{d-3}}$ is the usual differencing operator. Here $\mathbf{g}_1, \dots, \mathbf{g}_{d-3}, \mathbf{g}$ each run over vectors in $\mathbb{F}_q[T]^n$ formed from polynomials of degree less than $e - j + 1$. A further application of Cauchy–Schwarz now yields

$$|T(\mathbf{h})|^{2^{d-2}} \leq |P|^{(2^{d-2}-d+1)n} \sum_{\mathbf{g}_1, \dots, \mathbf{g}_{d-3}} \left| \sum_{\mathbf{g}} \psi(D(\mathbf{g})) \right|^2.$$

Differencing once more therefore leads to the expression

$$\left| \sum_{\mathbf{g}} \psi(D(\mathbf{g})) \right|^2 = \sum_{\mathbf{g}_{d-2}, \mathbf{g}_{d-1}} \psi(D_{\mathbf{g}_1, \dots, \mathbf{g}_{d-2}}(\alpha f(\mathbf{g}_{d-1}) + \beta \mathbf{h} \cdot \nabla f(\mathbf{g}_{d-1}))),$$

where

$$D_{\mathbf{g}_1, \dots, \mathbf{g}_{d-2}}(\mathbf{h} \cdot \nabla f(\mathbf{g}_{d-1})) = \sum_{i=1}^n h_i \Psi_i(\mathbf{g}_1, \dots, \mathbf{g}_{d-1}),$$

in the notation of (5-11). Returning to (5-15) we ignore the Diophantine approximation properties of α and instead execute the linear exponential sum over \mathbf{h} . This leads to the expression

$$|S(\alpha, \beta)| \leq |P|^n |Q|^n (|P|^{-(d-1)n} N(\beta, e - \varrho))^{1/2^{d-2}},$$

in the notation of (5-12). Again, $N(\beta, e - \varrho) \geq 1$ and $2^{d-2} \geq (d - 1)$ so the right side is $\geq |Q|^n$, whence

$$|S(\alpha, \beta) - q^{n(e-\varrho)}| \leq 2|P|^n |Q|^n (|P|^{-(d-1)n} N(\beta, e - \varrho))^{1/2^{d-2}}. \tag{5-16}$$

Remark 5.5. When $\text{char}(\mathbb{F}_q) \leq d$ the polynomials Ψ_i are identically zero for $1 \leq i \leq n$, so that (5-14) and (5-16) give nothing beyond the trivial bound for the exponential sum $S(\alpha, \beta)$.

Recall the definitions (5-4) and (5-6) of $\mathfrak{M}(J)$ and $\mathfrak{N}(K)$, respectively. We want to bound the size of $S(\alpha, \beta)$ when $\alpha \notin \mathfrak{M}(J)$ and $\beta \notin \mathfrak{N}(K)$. To do this it will be convenient to introduce two parameters s_1 and s_2 . Associated to these are the quantities

$$l_1 = e - j + 1 - s_1 \quad \text{and} \quad l_2 = e - j + 1 - s_2.$$

We can use our geometry-of-numbers shrinking result to establishing the following pair of estimates.

Lemma 5.6. *Let $\alpha \notin \mathfrak{M}(J)$ and let $l_1 \in \mathbb{Z}$ be such that*

$$l_1 \leq 1 + \frac{J}{d-1} \quad \text{and} \quad l_1 \leq e - j + 1.$$

Then there exists a constant $c_{d,n} > 0$ such that.

$$N(\alpha, e - j + 1) \leq c_{d,n} q^{-nl_1} |P|^{(d-1)n}.$$

Proof. It follows from Lemma 5.4 that $N(\alpha, e - j + 1)$ is at most

$$q^{(d-1)ns_1} \#\{\underline{\mathbf{g}} \in \mathbb{F}_q[T]^{(d-1)n} : |\mathbf{g}_1|, \dots, |\mathbf{g}_{d-1}| < |P|/q^{s_1}, \|\alpha \Psi_i(\underline{\mathbf{g}})\| < |P|^{-1} q^{-(d-1)s_1} (\forall i \leq n)\},$$

for any $s_1 \geq 0$. Note that $|P|/q^{s_1} = q^{l_1}$ and $q^{s_1} = |P_0|/q^{l_1-1}$. Suppose that

$$|\mathbf{g}_1|, \dots, |\mathbf{g}_{d-1}| < |P|/q^{s_1}$$

and $\|\alpha \Psi_i(\underline{\mathbf{g}})\| < |P|^{-1} q^{-(d-1)s_1}$ but $\Psi_i(\underline{\mathbf{g}}) \neq 0$. Let $r = \Psi_i(\underline{\mathbf{g}})$ and let a be the integer part of $\alpha \Psi_i(\underline{\mathbf{g}})$, each divided through by any common factors that they might share. Then $|r| \leq q^{(d-1)(l_1-1)}$ and

$$|r\alpha - a| < |P|^{-1} q^{-(d-1)s_1} = q^{(d-1)(l_1-1)-1} |P|_0^{-d}.$$

This contradicts the assumption that $\alpha \notin \mathfrak{M}(J)$, if $J \geq (d - 1)(l_1 - 1)$. Hence, if $J \geq (d - 1)(l_1 - 1)$ and $\alpha \notin \mathfrak{M}(J)$, we have

$$N(\alpha, e - j + 1) \leq q^{(d-1)ns_1} \#\{\underline{\mathbf{g}} \in \mathbb{F}_q[T]^{(d-1)n} : |\mathbf{g}_1|, \dots, |\mathbf{g}_{d-1}| < q^{l_1}, \Psi_i(\underline{\mathbf{g}}) = 0 (\forall i \leq n)\}.$$

The statement of the lemma follows on noting that the remaining cardinality is $O(q^{(d-2)nl_1})$ for dimensionality reasons, where the implied constant depends only on d and n . □

Lemma 5.7. *Let $\beta \notin \mathfrak{N}(K)$ and let $l_2 \in \mathbb{Z}$ be such that*

$$l_2 \leq 1 + \frac{K}{d-1} \quad \text{and} \quad l_2 \leq e - j + 1 - \max(0, \varrho - j + 1).$$

Then there exists a constant $c_{d,n} > 0$ such that.

$$N(\beta, e - \varrho) \leq c_{d,n} q^{-nl_2 + n \max(0, \lfloor (\varrho - j + 1)/2 \rfloor)} |P|^{(d-1)n}.$$

Proof. This time we take $r = e - \varrho$ in [Lemma 5.4](#) and deduce that

$$N(\beta, e - \varrho) \leq q^{(d-1)ns_2 + n \max(0, \lfloor (\varrho - j + 1)/2 \rfloor)} \times \#\{\underline{\mathbf{g}} \in \mathbb{F}_q[T]^{(d-1)n} : |\mathbf{g}_1|, \dots, |\mathbf{g}_{d-1}| < q^{l_2}, \|\beta \Psi_i(\underline{\mathbf{g}})\| < |Q|^{-1} q^{-(d-1)s_2} (\forall i \leq n)\},$$

for any $s_2 \geq \max(0, \varrho - j + 1)$. Arguing as in the previous result it is simple to check that we must in fact have $\Psi_i(\underline{\mathbf{g}}) = 0$ for all $1 \leq i \leq n$ whenever $\beta \notin \mathfrak{N}(K)$ and $K \geq (d-1)(l_2 - 1)$. But then there are $O(q^{(d-2)nl_2})$ possible vectors $\underline{\mathbf{g}} \in \mathbb{F}_q[T]^{(d-1)n}$ that contribute. The statement of the lemma follows. \square

In our work we shall take

$$l_1 = 1 + \left\lfloor \frac{J}{d-1} \right\rfloor, \quad l_2 = 1 + \left\lfloor \frac{K}{d-1} \right\rfloor. \tag{5-17}$$

We need to check that the remaining conditions on l_1 and l_2 are satisfied in [Lemmas 5.6](#) and [5.7](#). To begin with we note that

$$J \leq \left\lceil \frac{d(e-j)}{2} \right\rceil - 1 \leq \frac{d(e-j)}{2} - \frac{1}{2}.$$

Hence for [Lemma 5.6](#) to be applicable it suffices to have

$$d(e-j) - 1 \leq 2(d-1)(e-j).$$

But this is equivalent to $0 \leq 1 + (d-2)(e-j)$ which follows from [\(5-8\)](#). Next, we note that

$$K \leq \left\lceil \frac{(e-j)(d-1) + e - \varrho}{2} \right\rceil - 1 \leq \frac{(e-j)(d-1) + e - \varrho}{2} - \frac{1}{2},$$

so that [Lemma 5.7](#) is applicable if

$$e - \varrho - 1 \leq (d-1)(e - j - 2 \max(0, \varrho - j + 1)).$$

Thus it suffices to have

$$e - \varrho - 1 \leq (d-1)(e - j) \tag{5-18}$$

and

$$e - \varrho - 1 \leq (d-1)(e + j - 2\varrho - 2). \tag{5-19}$$

However, [\(5-18\)](#) follows from [\(5-8\)](#), so it suffices to assume that [\(5-19\)](#) holds.

Inserting Lemmas 5.6 and 5.7 into our Weyl differencing bounds (5-14) and (5-16), we deduce that there exists a constant $c_{d,n} > 0$ such that

$$|S(\alpha, \beta) - q^{n(e-\varrho)}| \leq c_{d,n} |P|^n |Q|^n \min(q^{-nl_1/2^{d-1}}, q^{-n(l_2-n \max(0, \lfloor (\varrho-j+1)/2 \rfloor)) / 2^{d-2}}) \\ = c_{d,n} |P|^n |Q|^n / \max(q^{l_1}, q^{2l_2-2 \max(0, \lfloor (\varrho-j+1)/2 \rfloor)}) n / 2^{d-1},$$

whenever $(\alpha, \beta) \in \mathfrak{M}(J+1) \setminus \mathfrak{M}(J) \times \mathfrak{N}(K+1) \setminus \mathfrak{N}(K)$ and (5-19) holds. We shall proceed under the assumption that the parameter l_2 satisfies

$$l_2 - \max\left(0, \left\lfloor \frac{\varrho - j + 1}{2} \right\rfloor\right) \geq 0. \tag{5-20}$$

This is precisely the circumstance under which our β -treatment is nontrivial. Assume that $n > (d-1)2^d$, so that $2^d(d-1)/n < 1$. If (5-20) holds we can invoke the inequality $\max(A, B) \geq A^{2^d(d-1)/n} B^{1-2^d(d-1)/n}$, which is valid for any $A, B \geq 1$. Thus it follows that

$$|S(\alpha, \beta) - q^{n(e-\varrho)}| \leq c_{d,n} \frac{q^{2(d-1)(2l_2-l_1)-4(d-1) \max(0, \lfloor (\varrho-j+1)/2 \rfloor)} |P|^n |Q|^n}{q^{(l_2-\max(0, \lfloor (\varrho-j+1)/2 \rfloor))n/2^{d-2}}}.$$

Returning to (5-2) we see that

$$\sum_{\substack{\mathbf{g} \in \mathbb{F}_q[T]^n \\ 0 < |\mathbf{g}| < q^{e-j+1} \\ f(\mathbf{g})=0}} \int_{n_j} S(\beta) d\beta \leq \sum_{J=-1}^{M-1} \sum_{K=e-\varrho}^{N-1} E(J, K)$$

where we recall from (5-5) and (5-7) that

$$M = \left\lceil \frac{d(e-j)}{2} \right\rceil, \quad N = \left\lceil \frac{(e-j)(d-1) + e - \varrho}{2} \right\rceil,$$

and

$$E(J, K) = \int_{\mathfrak{M}(J+1) \setminus \mathfrak{M}(J)} \int_{\mathfrak{N}(K+1) \setminus \mathfrak{N}(K)} |S(\alpha, \beta) - q^{n(e-\varrho)}| d\alpha d\beta.$$

The measure of all (α, β) in the integral is at most $q^{4+2J+2K} |P_0|^{-2d+1} |Q|^{-1}$, by (5-9) and (5-10). Let us consider the total contribution

$$E_{l_1, l_2} = \sum_{J=\max((d-1)(l_1-1), -1)}^{(d-1)l_1-1} \sum_{K=\max((d-1)(l_2-1), e-\varrho)}^{(d-1)l_2-1} E_{J, K},$$

from J, K associated to integers $l_1 \geq 0$ and $l_2 \geq 1$ via (5-17). Then

$$E_{l_1, l_2} \ll \frac{q^{6(d-1)l_2} |P|^n |Q|^{n-1} |P_0|^{-2d+1} q^{-4(d-1) \max(0, \lfloor (\varrho-j+1)/2 \rfloor)}}{q^{(l_2-\max(0, \lfloor (\varrho-j+1)/2 \rfloor))n/2^{d-2}}} \\ = q^{\Delta_j - l_2(n/2^{d-2} - 6(d-1)) + \max(0, \lfloor (\varrho-j+1)/2 \rfloor)(n/2^{d-2} - 4(d-1))},$$

where we have put

$$\Delta_j = (e-j)(n-2d+1) + (e-\varrho)(n-1) + n.$$

Because $K \geq e - \varrho$, we have

$$l_2 \geq 1 + \left\lfloor \frac{e - \varrho}{d - 1} \right\rfloor.$$

In particular our condition (5-20) is satisfied when

$$1 + \left\lfloor \frac{e - \varrho}{d - 1} \right\rfloor \geq \max\left(0, \left\lfloor \frac{\varrho - j + 1}{2} \right\rfloor\right). \tag{5-21}$$

Furthermore, assuming $n > 3(d - 1)2^{d-1}$, the bound is decreasing in l_2 , so the dominant contribution occurs when

$$l_2 = 1 + \left\lfloor \frac{e - \varrho}{d - 1} \right\rfloor.$$

Since there are $O(e)$ choices for l_1 , our work has therefore shown that

$$\sum_{\substack{\mathbf{g} \in \mathbb{F}_q[T]^n \\ 0 < |\mathbf{g}| < q^{e-j+1} \\ f(\mathbf{g})=0}} \int_{n_j} S(\beta) d\beta \ll eq^{\Delta_j - \Gamma_j},$$

where

$$\begin{aligned} \Gamma_j &= \left(\frac{n}{2^{d-2}} - 6(d-1)\right) \left(1 + \left\lfloor \frac{e - \varrho}{d - 1} \right\rfloor\right) - \left(\frac{n}{2^{d-2}} - 4(d-1)\right) \max\left(0, \left\lfloor \frac{\varrho - j + 1}{2} \right\rfloor\right) \\ &= \left(\frac{n}{2^{d-2}} - 6(d-1)\right) \left(1 + \left\lfloor \frac{e - \varrho}{d - 1} \right\rfloor - \max\left(0, \left\lfloor \frac{\varrho - j + 1}{2} \right\rfloor\right)\right) - 2(d-1) \max\left(0, \left\lfloor \frac{\varrho - j + 1}{2} \right\rfloor\right). \end{aligned}$$

Thus we certainly require (5-21) to hold in order to expect any saving in our minor arc estimate.

We summarize our argument in the following result.

Lemma 5.8. *Let $d \geq 3$ and $n > 3(d - 1)2^{d-1}$. Assume that $\varrho \geq -1$ and*

$$e \geq \max\left(\varrho + (d - 1) \left\lfloor \frac{\varrho + 1}{2} \right\rfloor, (\varrho + 1) \left(2 + \frac{1}{d - 2}\right)\right). \tag{5-22}$$

Then

$$N_q^{minor}(q, e, f) \ll eq^{\Delta_0 - \Gamma_0}$$

where

$$\Delta_0 = 2e(n - d) - \varrho(n - 1) + n$$

and

$$\Gamma_0 = \left(\frac{n}{2^{d-2}} - 6(d-1)\right) \left(1 + \left\lfloor \frac{e - \varrho}{d - 1} \right\rfloor - \left\lfloor \frac{\varrho + 1}{2} \right\rfloor\right) - 2(d-1) \left\lfloor \frac{\varrho + 1}{2} \right\rfloor.$$

Proof. Recall (5-1) and note that $\Delta_j = \Delta_0 - j(n - 2d + 1)$. Hence for the range of n in which we are interested we deduce from (4-2) that

$$|c_j| q^{\Delta_j - \Gamma_j} \ll q^{\Delta_0 - \Gamma_0},$$

for all $j \geq 0$. Moreover, Γ_0 takes the value recorded in the statement of the lemma when $\varrho \geq -1$ and the condition (5-22) on e is enough to ensure that (5-19) and (5-21) both hold for every $j \in \{0, 1, 2\}$. (For (5-19) we note that it suffices to have $e(d - 2) \geq (\varrho + 1)(2d - 3)$.) This completes the proof. \square

5C. Deduction of Theorem 1.1. We assume that $n > (2d - 1)2^{d-1}$. We revisit the argument deployed in [Browning and Vishe 2015] to establish the irreducibility and dimension of $\mathcal{M}_{0,0}(X, e)$. This is based on a counting argument over a finite field \mathbb{F}_q whose characteristic is greater than the degree d of the nonsingular form $f \in \mathbb{F}_q[x_1, \dots, x_n]$ that defines X . According to [loc. cit., Equation (3.3)], in order to deduce that $\mathcal{M}_{0,0}(X, e)$ is irreducible and of the expected dimension it suffices to show that

$$\lim_{q \rightarrow \infty} q^{-(n-d)e-n+1} \hat{N}(q, e, f) \leq 1, \tag{5-23}$$

where $\hat{N}(q, e, f)$ is the number of $\mathbf{g} \in \mathbb{F}_q[T]^n$ such that $|\mathbf{g}| < q^{e+1}$ and $f(\mathbf{g}) = 0$.

We have

$$\hat{N}(q, e, f) = \int_{\mathbb{T}} S_{\text{BV}}(\alpha) d\alpha,$$

where

$$S_{\text{BV}}(\alpha) = \sum_{\substack{\mathbf{g} \in \mathbb{F}_q[T]^n \\ |\mathbf{g}| < q^{e+1}}} \psi(\alpha f(\mathbf{g})) = q^{-n(e-\varrho)} S(\alpha, 0),$$

in the notation of (5-3), with $j = 0$. Take $j = 0$ in the major arcs $\mathfrak{M}(J)$ that were defined in (5-4). A straightforward calculation shows that the contribution from the major arc around 0 is

$$\int_{\mathfrak{M}(0)} S_{\text{BV}}(\alpha) d\alpha = \sum_{\substack{\mathbf{g} \in \mathbb{F}_q[T]^n \\ |\mathbf{g}| < q^{e+1}}} \int_{|\theta| < q^{-de}} \psi(\theta f(\mathbf{g})) d\theta = q^{ne-de} (q^{n-1} + O(q^{n/2})).$$

In order to complete the proof of (5-23) it therefore suffices to show that

$$\lim_{q \rightarrow \infty} q^{-(n-d)e-n+1} \sum_{J=0}^{M-1} \int_{\mathfrak{M}(J+1) \setminus \mathfrak{M}(J)} |S_{\text{BV}}(\alpha)| d\alpha < 1$$

where $M = \lceil de/2 \rceil$ is given by (5-5). To do this we may apply our previous work. Thus it follows from (5-14) and Lemma 5.6 that

$$S_{\text{BV}}(\alpha) \ll |P|^n q^{-nl_1/2^{d-1}},$$

if $\alpha \notin \mathfrak{M}(J)$ and l_1 is any integer such that $l_1 \leq 1 + J/(d - 1)$ and $l_1 \leq e + 1$. The choice $l_1 = 1 + \lfloor J/(d - 1) \rfloor$ is acceptable since $J \leq \lceil de/2 \rceil - 1 \leq (de - 1)/2$, whence

$$l_1 \leq 1 + \frac{de - 1}{2(d - 1)} = 1 + e,$$

for $d \geq 3$. Since $J \geq 0$ we are clearly only interested in integers $l_1 \geq 1$. Appealing to (5-9) to estimate the volume of $\mathfrak{M}(J + 1)$, we deduce that for given $l_1 \geq 1$ the total associated contribution is

$$\begin{aligned} \sum_{J=(d-1)(l_1-1)}^{(d-1)l_1-1} \int_{\mathfrak{M}(J+1) \setminus \mathfrak{M}(J)} |S_{BV}(\alpha)| d\alpha &\ll \sum_{J=(d-1)(l_1-1)}^{(d-1)l_1-1} q^{2J+2-de} \cdot |P|^n q^{-nl_1/2^{d-1}} \\ &\ll q^{-de+n(e+1)+(2(d-1)-n/2^{d-1})l_1}. \end{aligned}$$

This is decreasing with l_1 if $n > (d - 1)2^d$ and we may therefore sum over $l_1 \geq 1$ to finally deduce that

$$q^{-(n-d)e-n+1} \sum_{J=0}^{M-1} \int_{\mathfrak{M}(J+1) \setminus \mathfrak{M}(J)} |S_{BV}(\alpha)| d\alpha \ll q^{1+2(d-1)-n/2^{d-1}}.$$

The exponent of q is negative if $n > (2d - 1)2^{d-1}$, which thereby concludes the proof of (5-23), whence $\mathcal{M}_{0,0}(X, e)$ is indeed irreducible and of the expected dimension. It follows from the same method used in [Harris et al. 2004, page 2] that $\mathcal{M}_{0,0}(X, e)$ is locally a complete intersection. Indeed, since $\mathcal{M}_{0,0}(X, e)$ is locally the intersection of $de + 1$ equations in $\mathcal{M}_{0,0}(\mathbb{P}^{n-1}, e)$, a smooth stack of dimension $ne - 4$, it is a locally complete intersection if and only if its dimension is $(n - d)e + n - 5$.

5D. Deduction of Theorem 1.5. Assume that $d \geq 3, n > 3(d-1)2^{d-1}, \varrho \geq -1$, and $e \geq (\varrho+1)(2+(1)/d-2)$. In particular, this implies that $e \geq \varrho$, which is needed for Lemma 5.1. In view of Theorem 1.1, the stated bound is trivial unless $1 + \lfloor (e - \varrho)/(d - 1) \rfloor - \lfloor (\varrho + 1)/2 \rfloor > 0$, so we may assume that $\lfloor (e - \varrho)/(d - 1) \rfloor - \lfloor (\varrho + 1)/2 \rfloor \geq 0$ and thus $e \geq \varrho + (d - 1)\lfloor (\varrho + 1)/2 \rfloor$. Hence we may assume that (5-22) holds.

Combining Lemmas 5.1 and 5.8 we deduce that

$$\#Z_\varrho(\mathbb{F}_q) \ll e q^{e(n-d)+n-5-\min(\mu_1(n), \mu_2(n))}, \tag{5-24}$$

with

$$\mu_1(n) = \left(\frac{n}{2^{d-2}} - 6(d-1) \right) \left(1 + D - \left\lfloor \frac{\varrho+1}{2} \right\rfloor \right) - 2(d-1) \left\lfloor \frac{\varrho+1}{2} \right\rfloor$$

and

$$\mu_2(n) = (1 + D)(n - d - 1) - de + e + 1.$$

Here we recall that D is given by (4-7) as $\lfloor (e - \varrho)/(d - 1) \rfloor$.

We claim that $\mu_1(n) \leq \mu_2(n)$. They are both increasing affine functions of n , with $\mu_1(n)$ of lesser slope than $\mu_2(n)$. Hence to check that $\mu_1(n)$ is the minimum, it suffices to check that $\mu_2(n) \geq 0$ and $\mu_1(n) \leq 0$ when $n = 3(d - 1)2^{d-1}$. In other words, we must show that

$$3(d - 1)2^{d-1} \geq d + 1 + \frac{e(d - 1) - 1}{1 + D}.$$

To do this, observe that because $e \geq \varrho + (d - 1)\lfloor (\varrho + 1)/2 \rfloor$ we have $e \geq ((d + 1)/2)\varrho$, so that

$$1 + D \geq \frac{e + 1 - \varrho}{d - 1} \geq \frac{e + 1 - (2/(d + 1))e}{d - 1} \geq \frac{e}{d + 1}.$$

Thus

$$d + 1 + \frac{e(d - 1) - 1}{1 + D} \leq d + 1 + \frac{e(d - 1)}{e/(d + 1)} = d(d + 1),$$

so it suffices to check

$$3(d - 1)2^{d-1} \geq d(d + 1).$$

But it is clear that this holds for all $d \geq 3$, whence $\mu_2(n) \geq \mu_1(n)$.

By [Lang and Weil 1954], it now follows from (5-24) that

$$\dim Z_\varrho \leq e(n - d) + n - 5 - \mu_1(n)$$

for any smooth hypersurface defined over a finite field. For a general hypersurface, we can spread it out to a family defined over a ring finitely generated over \mathbb{Z} . The dimension of Z_ϱ in this family is manifestly constant on some open subset of the spectrum of this ring, which must contain a finite-field valued point, so $\dim Z_\varrho$ is at most $e(n - d) + n - 5 - \mu_1(n)$ for the generic point and thus for the original hypersurface. This completes the proof of Theorem 1.5.

5E. Deduction of Theorem 1.2. We consider the effect of taking $\varrho = -1$ in Theorem 1.5. Clearly (1-1) is equivalent to $e \geq 0$ and can be ignored. Note that Z_{-1} contains the singular locus of $\mathcal{M}_{0,0}(X, e)$ by [Debarre 2001, Theorem 2.6]. Thus the codimension of the singular locus is at least $\dim \mathcal{M}_{0,0}(X, e) - \dim Z_{-1}$. Theorem 1.2 therefore follows from applying Theorem 1.1 to calculate $\dim \mathcal{M}_{0,0}(X, e)$ and Theorem 1.5 to bound $\dim Z_{-1}$.

Because the lower bound for the codimension of the singular locus is strictly positive, the moduli space is generically smooth. Any generically smooth locally complete intersection scheme is reduced, which thereby completes the proof of Theorem 1.1.

6. Peyre’s freedom counting function

In this section we prove the asymptotic formula in Theorem 1.6 for the counting function (1-4), by piecing together our work above and the main results in Lee’s thesis [2013]. We have

$$N_X^{\varepsilon\text{-free}}(B) = N_X(B) - E_\varepsilon(B), \tag{6-1}$$

where $E_\varepsilon(B)$ counts the number of $x \in X(\mathbb{F}_q(T))$ with $H_{\omega_V^{-1}}(x) \leq q^B$ such that $\ell(x) < \varepsilon$.

Let us begin by studying $N_X(B)$. As usual we suppose that X is defined by a nonsingular form $f \in \mathbb{F}_q[x_1, \dots, x_n]$ of degree $d \geq 3$. It follows from the proof of part (1) of Proposition 3.8 that

$$N_X(B) = \frac{1}{q - 1} \#\{\mathbf{g} \in \mathbb{F}_q[T]^n : \gcd(g_1, \dots, g_n) = 1 | \mathbf{g} |^{n-d} < q^{B+1}, f(\mathbf{g}) = 0\}.$$

Using the Möbius function to detect the coprimality condition we obtain

$$\begin{aligned}
 N_X(B) &= \frac{1}{q-1} \sum_{\substack{k \in \mathbb{F}_q[T] \\ k \text{ monic}}} \mu(k) \#\{\mathbf{g} \in \mathbb{F}_q[T]^n : 0 < |k\mathbf{g}|^{n-d} < q^{B+1}, f(\mathbf{g}) = 0\} \\
 &= \frac{1}{q-1} \sum_{j \geq 0} \sum_{\substack{k \in \mathbb{F}_q[T] \\ |k|=q^j \\ k \text{ monic}}} \mu(k) \#\{\mathbf{g} \in \mathbb{F}_q[T]^n : 0 < |\mathbf{g}|^{n-d} < q^{B+1-j(n-d)}, f(\mathbf{g}) = 0\}.
 \end{aligned}$$

Put $m = n - (d - 1)2^d$ and assume that $m > 0$. Then, on appealing to Lee’s thesis [2013, Theorem 4.1.1], it follows that

$$\#\{\mathbf{g} \in \mathbb{F}_q[T]^n : 0 < |\mathbf{g}|^{n-d} < q^{R+1}, f(\mathbf{g}) = 0\} = q^R(c_f + O(q^{-mR/(2^{d+1}(d-1)(n-d)})), \tag{6-2}$$

for any $R > 0$, where c_f is the usual product of singular series and singular integral. Using (4-1) to handle the sum over j and k , it now follows from (6-2) that there exists $\delta > 0$ such that

$$N_X(B) = \frac{c_f}{(q-1)\zeta_{\mathbb{F}_q(T)}(n-d)} q^B + O(q^{(1-\delta)B}),$$

where $\zeta_{\mathbb{F}_q(T)}(s) = (1 - q^{1-s})^{-1}$ is the rational zeta function. Arguing along standard lines (as in Peyre [Peyre 1995, Section 5.4], for example), one readily confirms that this agrees with the Batyrev–Manin–Peyre prediction for the hypersurface X .

It remains to produce an upper bound for the quantity $E_\varepsilon(B)$ in (6-1). Let $x \in X(\mathbb{F}_q(T))$ and suppose that it defines a map $c : \mathbb{P}^1 \rightarrow X$ of degree e . Then it follows from [Peyre 2017, Notation 5.7] that

$$\ell(x) = \frac{(n-1)\varrho}{e(n-d)}$$

if and only if c is ϱ -free but not $(\varrho+1)$ -free. (In particular, Remark 1.4 implies that $\ell(x) \in [0, 1]$.) We deduce that $E_\varepsilon(B)$ is at most the number of rational maps from $\mathbb{P}^1 \rightarrow X$ with degree at most $B/(n-d)$ which are not ϱ -free, with

$$\varrho = \left\lfloor \frac{\varepsilon B}{n-1} \right\rfloor + 2. \tag{6-3}$$

We may therefore appeal to the proof of Proposition 3.8(2) to estimate this quantity, finding that

$$E_\varepsilon(B) \leq \frac{N_\varrho(q, B/(n-d), f)q^{\varrho(n-1)-B} - N(q, B/(n-d), f)}{(q-1)^2},$$

with ϱ given by (6-3). In what follows it will be convenient to set $e = B/(n-d)$ and to assume that $e \in \mathbb{N}$. All of the implied constants that follow are allowed to depend on q and f , but not on e or ϱ . We seek conditions on n and ϱ under which we can deduce that there exists $\delta > 0$ such that $E_\varepsilon(B) = O(q^{(1-\delta)e(n-d)})$.

First we improve our treatment of Lemma 4.4 slightly by revisiting the argument (4-10). Since we no longer care about a dependence on the finite field, rather than invoking a trivial bound we may apply

(6-2) to deduce that $N(q, u - \ell, f) \ll q^{(u-\ell)(n-d)}$ if $n > (d - 1)2^d$. But then (4-10) can be replaced by the bound

$$E_j \ll_f \sum_{0 \leq u \leq e-j} q^{u(n-2d+1)} \sum_{\ell \geq D+1+j-e+u} q^{-\ell(n-2d)} \ll_f q^{(e-j)(n-2d+1)-(D+1)(n-2d)},$$

where D is given by (4-7), whence

$$q^{(n-1)(e-\varrho)} \sum_{j \geq 0} |c_j| E_j \ll_f q^{2e(n-d)-\varrho(n-1)-(D+1)(n-2d)} \ll_f q^{2e(n-d)-\varrho(n-1)-(e-\varrho)(n-2d)/(d-1)}.$$

It now follows from (4-3) and our modified version of Lemma 4.4 that

$$E_\varepsilon(B) \ll q^{e(n-d)-(e-\varrho)(n-2d)/(d-1)} + q^{-e(n-d)+\varrho(n-1)} N_\varrho^{\text{minor}}(q, e, f),$$

provided that $e \geq \varrho$. Note that $\Gamma_0 = \gamma_0 + O_{d,n}(1)$, with

$$\gamma_0 = \left(\frac{n}{2^{d-2}} - 6(d-1) \right) \left(\frac{e-\varrho}{d-1} - \frac{\varrho}{2} \right) - (d-1)\varrho.$$

Appealing now to Lemma 5.8 we therefore deduce that

$$E_\varepsilon(B) \ll q^{e(n-d)-(e-\varrho)(n-2d)/(d-1)} + e q^{e(n-d)-\gamma_0}$$

if (5-22) holds.

Recall that $n > 3(d-1)2^{d-1}$. Then $n/2^{d-2} - 6(d-1) \geq 2^{-d+2}$ and we can ensure that $\gamma_0 \geq \delta e$ for a small parameter $\delta > 0$ (that depends only on d) provided that

$$e \geq (d-1)^2 2^{d-1} \varrho. \tag{6-4}$$

This is also enough to ensure that $(e-\varrho)(n-2d)/(d-1) \geq \delta e$. This inequality is clearly much stronger than (5-22). The statement of Theorem 1.6 now follows on taking $e = B/(n-d)$ and noting that the hypothesis on ε in the theorem is enough to ensure that (6-4) holds when ϱ is given by (6-3) and B is sufficiently large.

Acknowledgements

The authors are grateful to Paul Nelson, Per Salberger and Jason Starr for useful comments. While working on this paper the first author was supported by EPSRC grant EP/P026710/1. The research was partially conducted during the period the second author served as a Clay Research Fellow, and partially conducted during the period he was supported by Dr. Max Rössler, the Walter Haefner Foundation and the ETH Zurich Foundation.

References

- [Browning and Sawin 2020a] T. Browning and W. Sawin, “Free rational points on smooth hypersurfaces”, *Comment. Math. Helv.* **95**:4 (2020), 635–659. [MR](#) [Zbl](#)
- [Browning and Sawin 2020b] T. Browning and W. Sawin, “A geometric version of the circle method”, *Ann. of Math. (2)* **191**:3 (2020), 893–948. [MR](#) [Zbl](#)
- [Browning and Vishe 2015] T. D. Browning and P. Vishe, “Rational points on cubic hypersurfaces over $\mathbb{F}_q(t)$ ”, *Geom. Funct. Anal.* **25**:3 (2015), 671–732. [MR](#) [Zbl](#)
- [Browning and Vishe 2017] T. Browning and P. Vishe, “Rational curves on smooth hypersurfaces of low degree”, *Algebra Number Theory* **11**:7 (2017), 1657–1675. [MR](#) [Zbl](#)
- [Campana 1992] F. Campana, “Connexité rationnelle des variétés de Fano”, *Ann. Sci. École Norm. Sup. (4)* **25**:5 (1992), 539–545. [MR](#) [Zbl](#)
- [Debarre 2001] O. Debarre, *Higher-dimensional algebraic geometry*, Springer, 2001. [MR](#) [Zbl](#)
- [Eisenbud and Harris 2016] D. Eisenbud and J. Harris, *3264 and all that—a second course in algebraic geometry*, Cambridge University Press, 2016. [MR](#) [Zbl](#)
- [Franke et al. 1989] J. Franke, Y. I. Manin, and Y. Tschinkel, “Rational points of bounded height on Fano varieties”, *Invent. Math.* **95**:2 (1989), 421–435. [MR](#) [Zbl](#)
- [Harris et al. 2004] J. Harris, M. Roth, and J. Starr, “Rational curves on hypersurfaces of low degree”, *J. Reine Angew. Math.* **571** (2004), 73–106. [MR](#) [Zbl](#)
- [Hartshorne 1977] R. Hartshorne, *Algebraic geometry*, Graduate Texts in Mathematics **52**, Springer, 1977. [MR](#) [Zbl](#)
- [Kollár 1996] J. Kollár, *Rational curves on algebraic varieties*, *Ergeb. Math. Grenzgeb.* **32**, Springer, 1996. [MR](#)
- [Kollár et al. 1992a] J. Kollár, Y. Miyaoka, and S. Mori, “Rational connectedness and boundedness of Fano manifolds”, *J. Differential Geom.* **36**:3 (1992), 765–779. [MR](#) [Zbl](#)
- [Kollár et al. 1992b] J. Kollár, Y. Miyaoka, and S. Mori, “Rationally connected varieties”, *J. Algebraic Geom.* **1**:3 (1992), 429–448. [MR](#) [Zbl](#)
- [Lang and Weil 1954] S. Lang and A. Weil, “Number of points of varieties in finite fields”, *Amer. J. Math.* **76** (1954), 819–827. [MR](#) [Zbl](#)
- [Lee 2013] S. Lee, *On the applications of the circle method to function fields, and related topics*, Ph.D. thesis, University of Bristol, 2013.
- [Mustață 2001] M. Mustață, “Jet schemes of locally complete intersection canonical singularities”, *Invent. Math.* **145**:3 (2001), 397–424. [MR](#) [Zbl](#)
- [Peyre 1995] E. Peyre, “Hauteurs et mesures de Tamagawa sur les variétés de Fano”, *Duke Math. J.* **79**:1 (1995), 101–218. [MR](#) [Zbl](#)
- [Peyre 2017] E. Peyre, “Liberté et accumulation”, *Doc. Math.* **22** (2017), 1615–1659. [MR](#) [Zbl](#)
- [Riedl and Yang 2019] E. Riedl and D. Yang, “Kontsevich spaces of rational curves on Fano hypersurfaces”, *J. Reine Angew. Math.* **748** (2019), 207–225. [MR](#) [Zbl](#)
- [Starr 2003] J. Starr, “The Kodaira dimension of spaces of rational curves on low degree hypersurfaces”, preprint, 2003. [arXiv math/0305432](#)

Communicated by Philippe Michel

Received 2021-06-28 Revised 2022-02-24 Accepted 2022-04-22

tdb@ist.ac.at

Institute of Science and Technology Austria, Am Campus 1, Austria

sawin@math.columbia.edu

Department of Mathematics, Columbia University, New York, NY, United States

Optimal lifting for the projective action of $\mathrm{SL}_3(\mathbb{Z})$

Amitay Kamber and Hagai Lavner

Let $\epsilon > 0$ and let $q \rightarrow \infty$ be a prime. We prove that with high probability, given x, y in the projective plane over \mathbb{F}_q , there exists $\gamma \in \mathrm{SL}_3(\mathbb{Z})$, with coordinates bounded by $q^{1/3+\epsilon}$, whose projection to $\mathrm{SL}_3(\mathbb{F}_q)$ sends x to y . The exponent $\frac{1}{3}$ is optimal and the result is a high rank generalization of Sarnak's optimal strong approximation theorem for $\mathrm{SL}_2(\mathbb{Z})$.

1. Introduction

In a letter to Miller and Talebizadeh, Sarnak [2015] proved the following lifting theorem, which he called optimal strong approximation.

Theorem 1.1. *Let $\Gamma = \mathrm{SL}_2(\mathbb{Z})$, $q \in \mathbb{Z}_{>0}$, $G_q = \mathrm{SL}_2(\mathbb{Z}/q\mathbb{Z})$ and let $\pi_q : \Gamma \rightarrow G_q$ be the quotient map. Then for every $\epsilon > 0$, as $q \rightarrow \infty$, there exists a set $Y \subset G_q$ of size $|Y| \geq |G_q|(1 - o_\epsilon(1))$, such that for every $y \in Y$ there exists $\gamma \in \Gamma$ of norm $\|\gamma\|_\infty \leq q^{3/2+\epsilon}$, with $\pi_q(\gamma) = y$, where $\|\cdot\|_\infty$ is the infinity norm on the coordinates of the matrix.*

The exponent $\frac{3}{2}$ in Theorem 1.1 is optimal, as the size of G_q is asymptotic to q^3 , while the number of $\gamma \in \mathrm{SL}_2(\mathbb{Z})$ satisfying $\|\gamma\|_\infty \leq T$ grows asymptotically like the Haar measure of the ball B_T of radius T in $\mathrm{SL}_2(\mathbb{R})$ [Duke et al. 1993; Maucourant 2007], i.e., $\mu(B_T) \asymp T^2$.

We use the standard notation $x \ll_z y$ to say that there is a constant C depending only on z such that $x \leq Cy$, and $x \asymp_z y$ means that $x \ll_z y$ and $y \ll_z x$.

We wish to discuss extensions of this theorem to SL_3 , with a view towards general SL_N . If $\Gamma = \mathrm{SL}_N(\mathbb{Z})$, then the number of $\gamma \in \Gamma$ of satisfying $\|\gamma\|_\infty \leq T$ also grows like the Haar measure of the ball of radius T in $\mathrm{SL}_N(\mathbb{R})$, i.e., $\mu(B_T) \asymp T^{N^2-N}$ [Duke et al. 1993; Maucourant 2007], while the size of $G_q = \mathrm{SL}_N(\mathbb{Z}/q\mathbb{Z})$ is $|G_q| \asymp q^{N^2-1}$. One is therefore led to the following:

Conjecture 1.2. *Let $\Gamma = \mathrm{SL}_N(\mathbb{Z})$, $q \in \mathbb{Z}_{>0}$, $G_q = \mathrm{SL}_N(\mathbb{Z}/q\mathbb{Z})$ and let $\pi_q : \Gamma \rightarrow G_q$ be the quotient map. Then for every $\epsilon > 0$, as $q \rightarrow \infty$, there exists a set $Y \subset G_q$ of size $|Y| \geq |G_q|(1 - o_\epsilon(1))$, such that for every $y \in Y$ there exists $\gamma \in \Gamma$ of norm $\|\gamma\|_\infty \leq q^{(N^2-1)/(N^2-N)+\epsilon}$, with $\pi_q(\gamma) = y$, where $\|\cdot\|_\infty$ is the infinity norm on the coordinates of the matrix.*

While we were unable to prove Conjecture 1.2 even for $N = 3$, we prove a similar theorem for a nonprincipal congruence subgroup of $\mathrm{SL}_3(\mathbb{Z})$. For a prime q , let \mathbb{F}_q be the field with q elements, let

MSC2020: 11F06.

Keywords: optimal lifting, congruence subgroups.

$P_q = P^2(\mathbb{F}_q)$ be the 2-dimensional projective space over \mathbb{F}_q , i.e., the set of vectors $\begin{pmatrix} a \\ b \\ c \end{pmatrix}$, $a, b, c \in \mathbb{F}_q$ not all 0, modulo the equivalence relation $\begin{pmatrix} a \\ b \\ c \end{pmatrix} \sim \begin{pmatrix} \alpha a \\ \alpha b \\ \alpha c \end{pmatrix}$ for $\alpha \in \mathbb{F}_q^\times$. The group $\text{SL}_3(\mathbb{F}_q)$ acts naturally on P_q , and by composing this action with π_q we have an action $\Phi_q : \text{SL}_3(\mathbb{Z}) \rightarrow \text{Sym}(P_q)$.

Theorem 1.3. *Let $\Gamma = \text{SL}_3(\mathbb{Z})$, and for a prime q let $P_q = P^2(\mathbb{F}_q)$ and $\Phi_q : \text{SL}_3(\mathbb{Z}) \rightarrow \text{Sym}(P_q)$ as above. Then for every $\epsilon > 0$, as $q \rightarrow \infty$, there exists a set $Y \subset P_q$ of size $|Y| \geq (1 - o_\epsilon(1))|P_q|$, such that for every $x \in Y$, there exists a set $Z_x \subset P_q$ of size $|Z_x| \geq (1 - o_\epsilon(1))|P_q|$, such that for every $y \in Z_x$, there exists an element $\gamma \in \Gamma$ satisfying $\|\gamma\|_\infty \leq q^{1/3+\epsilon}$, such that $\Phi_q(\gamma)x = y$.*

The exponent $\frac{1}{3}$ is optimal, since the size of P_q is $|P_q| \asymp q^2$, while the number of elements $\gamma \in \text{SL}_3(\mathbb{Z})$ satisfying $\|\gamma\|_\infty \leq T$ is $\asymp T^6$.

An alternative formulation of [Theorem 1.3](#) is that for all but $o_\epsilon(|P_q|^2)$ of pairs $(x, y) \in P_q \times P_q$, there exists an element $\gamma \in \Gamma$ satisfying $\|\gamma\|_\infty \leq q^{1/3+\epsilon}$ such that $\Phi_q(\gamma)x = y$. However, in this formulation it is a bit harder to see why the exponent $1/3$ is optimal, and our proof actually uses the formulation of [Theorem 1.3](#) as stated.

An important observation is that the premise of [Theorem 1.3](#) actually fails for the point $x = \mathbf{1} = \begin{pmatrix} 0 \\ 0 \\ 1 \end{pmatrix} \in P_q$. Elements sending $\mathbf{1}$ to $\begin{pmatrix} a \\ b \\ c \end{pmatrix} \in P_q$ necessarily have the third column modulo q equivalent to $\begin{pmatrix} a \\ b \\ c \end{pmatrix}$ (modulo the action of \mathbb{F}_q^\times). Since there are only $\asymp T^3$ possibilities for the third column, we need to consider matrices of infinity norm at least $q^{2/3}$ in order to reach from $x = \mathbf{1}$ to almost all of $y \in P_q$. As a matter of fact, one may use the explicit property (T) of $\text{SL}_3(\mathbb{R})$ from [\[Oh 2002\]](#) together with ideas from [\[Ghosh et al. 2018\]](#) to deduce that if we allow the size of the matrices to reach $q^{2/3+\epsilon}$ we may replace the set Y in [Theorem 1.3](#) by the entire set P_q .

We deduce [Theorem 1.3](#) from a lattice point counting argument, in the spirit of the work of Sarnak and Xue [\[1991\]](#). To state it, we first define a different gauge of largeness on $\text{SL}_3(\mathbb{Z})$ by $\|\gamma\|_\infty \|\gamma^{-1}\|_\infty$. The number of $\gamma \in \text{SL}_3(\mathbb{Z})$ satisfying $\|\gamma\|_\infty \|\gamma^{-1}\|_\infty \leq T$ grows asymptotically like $T^2 \log T$ [\[Maucourant 2007\]](#). Note that if $\|\gamma\|_\infty \leq T$ then $\|\gamma^{-1}\|_\infty \leq 2T^2$. In particular, the ball of radius $2T$ relatively to $\|\cdot\|_\infty \|\cdot^{-1}\|_\infty$ contains the ball of radius $T^{1/3}$ relatively to $\|\cdot\|_\infty$, and their volume is asymptotically the same up to $T^{o(1)}$. The counting result is as follows:

Theorem 1.4. *Let $\Gamma = \text{SL}_3(\mathbb{Z})$, and for a prime q let $P_q = P^2(\mathbb{F}_q)$ and $\Phi_q : \text{SL}_3(\mathbb{Z}) \rightarrow \text{Sym}(P_q)$ as above. Then there exists a constant $C > 0$ such that for every prime q , $T \leq Cq^2$ and $\epsilon > 0$ it holds that*

$$|\{(\gamma, x) \in \text{SL}_3(\mathbb{Z}) \times P^2(\mathbb{F}_q) : \|\gamma\|_\infty \|\gamma^{-1}\|_\infty \leq T, \Phi_q(\gamma)(x) = x\}| \ll_\epsilon q^{2+\epsilon} T.$$

Underlying [Conjecture 1.2](#) is the principal congruence subgroup $\Gamma(q) = \ker \pi_q$. Let $\mathbf{1} = \begin{pmatrix} 0 \\ 0 \\ 1 \end{pmatrix} \in P_q$. Then the group

$$\Gamma'_0(q) = \{\gamma \in \text{SL}_3(\mathbb{Z}) : \Phi_q(\gamma)(\mathbf{1}) = \mathbf{1}\} = \left\{ \begin{pmatrix} * & * & a \\ * & * & b \\ * & * & * \end{pmatrix} \in \text{SL}_3(\mathbb{Z}) : a = b = 0 \pmod q \right\}$$

is a nonprincipal congruence subgroup of $\text{SL}_3(\mathbb{Z})$. [Theorem 1.3](#) says that [Conjecture 1.2](#) holds “on average” for the nonprincipal congruence subgroup $\Gamma'_0(q)$.

Conjecturally, such “optimal lifting on average” should hold for every sequence of congruence subgroups of $\Gamma = \mathrm{SL}_N(\mathbb{Z})$, i.e., subgroups of some $\Gamma(q)$, $q > 1$ an integer. We provide a further example of this phenomenon for the action of $\mathrm{SL}_3(\mathbb{Z})$ on flags of \mathbb{F}_q^3 in [Theorem 5.1](#).

Let us provide a spectral context for our results, namely Sarnak’s density conjecture for exceptional eigenvalues. See also [\[Golubev and Kamber 2020\]](#) for a more detailed discussion.

[Theorem 1.1](#) follows from Selberg’s conjecture about the smallest nontrivial eigenvalue of the Laplacian of the hyperbolic surfaces $\Gamma(q)\backslash\mathcal{H}$, where \mathcal{H} is the hyperbolic plane and $\Gamma(q)$ is the q -th principal congruence subgroup of $\Gamma = \mathrm{SL}_2(\mathbb{Z})$. While Selberg’s conjecture remains widely open, Sarnak proved [Theorem 1.1](#) using density estimates on exceptional eigenvalues of the Laplacian, which are due to Huxley [\[1986\]](#). Similar density results were proved by Sarnak and Xue [\[1991\]](#) using lattice point counting arguments, but only for arithmetic quotients which are compact. The compactness assumption was removed in [\[Huntley and Katznelson 1993; Gamburd 2002\]](#) (and the results were moreover extended to some thin subgroups of $\mathrm{SL}_2(\mathbb{Z})$). As a matter of fact, in rank 1 the density property is equivalent to the lattice point counting property [\[Golubev and Kamber 2020\]](#).

In higher rank, [Conjecture 1.2](#) would similarly follow from a naive Ramanujan conjecture for $\Gamma(q)\backslash\mathrm{SL}_N(\mathbb{R})$, $\Gamma = \mathrm{SL}_N(\mathbb{Z})$, which says (falsely!) that the representation of $\mathrm{SL}_N(\mathbb{R})$ on $L^2(\Gamma(q)\backslash\mathrm{SL}_N(\mathbb{R}))$ decomposes into a trivial representation and a tempered representation. Burger, Li and Sarnak’s explanation of the failure of the naive Ramanujan conjecture [\[Burger et al. 1992\]](#) is closely related to the behavior of the point $x_0 = \mathbf{1} \in P_q$. As in rank 1, [Theorem 1.4](#) should be equivalent to density estimates for $\Gamma'_0(q)$, but there are some technical problems coming from the fact that $\mathrm{SL}_3(\mathbb{Z})$ is not cocompact [\[Golubev and Kamber 2020\]](#). Closely related density results were recently proven by Blomer, Buttcane and Maga for $N = 3$ in [\[Blomer et al. 2017\]](#), and for general N by [\[Blomer 2019\]](#), using the Kuznetsov trace formula, and it is very likely that [Theorem 1.3](#) can also be proven (and generalized to $N > 3$) using those density arguments. There are some technical problems with the implementation of this approach, for example, the results of [\[Blomer et al. 2017\]](#) and [\[Blomer 2019\]](#) concern cusp forms, and one has to deal with the presence of nontempered Eisenstein representations and some other technical issues. Moreover, those results are limited to subgroups similar to $\Gamma'_0(q)$, and are not available in the context of [Theorem 5.1](#). Our counting approach is more elementary, and is easier to generalize to other contexts.

The approach of this article can be carried far more generally. We refer to [\[Golubev and Kamber 2020\]](#) where the approach is studied in detail and in great generality. In particular, counting results such as [Theorem 1.4](#) (called the *weak injective radius property* by Golubev and Kamber), imply optimal lifting results such as [Theorem 1.3](#); see [\[loc. cit., Theorem 1.5\]](#). In particular, the right counting theorem will imply [Conjecture 1.2](#). Our restriction to $N = 3$ and the cases considered in [Theorems 1.3](#) and [5.1](#) follows from the fact that in those cases we can prove the relevant counting theorems, namely [Theorems 1.4](#) and [5.2](#). Such counting results are available in rank 1 following [\[Sarnak and Xue 1991\]](#), but as far as we know are new in rank greater than 1. As explained in [\[Golubev and Kamber 2020\]](#), the counting theorems are closely related to some spectral questions as in the rank 1 case discussed above, but the fact that the space is not compact significantly complicates matters. We refer again to [\[Sarnak and Xue 1991\]](#) for a more complete discussion.

Structure of the article. We provide a proof of [Theorem 1.1](#) in [Section 2](#), which serves as a guideline for the harder case of SL_3 . The main difference between our proof and the proof in [\[Sarnak 2015\]](#) is that we avoid using spectral decomposition, which is far harder in SL_3 .

In [Section 3](#) we prove [Theorem 1.4](#). The proof uses basic number theory and linear algebra.

In [Section 4](#) we deduce [Theorem 1.3](#) from [Theorem 1.4](#). The argument is analytic, and uses various tools from spectral analysis and representation theory, which include property (T), the pretrace formula (in a disguised form), and bounds on Harish-Chandra's Ξ function. This section is based on a general framework developed by the first author with Konstantin Golubev surrounding similar questions [\[Golubev and Kamber 2020\]](#).

Finally, in [Section 5](#) we prove [Theorem 5.1](#) which is a variant of [Theorem 1.3](#) for the action of $\mathrm{SL}_3(\mathbb{Z})$ on flags of \mathbb{F}_q^3 .

2. Proof of [Theorem 1.1](#)

The basic input for the proof of [Theorem 1.1](#) is the following counting result, proved in [\[Gamburd 2002, Lemma 5.3\]](#); it also appeared earlier, e.g., in [\[Huxley 1986\]](#).

Lemma 2.1. *Let $\epsilon > 0$. Then for every $q \in \mathbb{N}$, the size of the set*

$$\{\gamma \in \mathrm{SL}_2(\mathbb{Z}) : \gamma = I \pmod{q}, \|\gamma\|_\infty \leq T\}$$

is bounded by $\ll_\epsilon T^\epsilon (T^2/q^3 + T/q + 1)$.

Proof. Let $\gamma = \begin{pmatrix} a & b \\ c & d \end{pmatrix} \in \mathrm{SL}_2(\mathbb{Z})$ be in the set. It holds that $\gamma - I \in qM_n(\mathbb{Z})$, so $\det(\gamma - I) = 0 \pmod{q^2}$, or explicitly

$$(a - 1)(d - 1) - bc = 0 \pmod{q^2}.$$

Since $ad - bc = 1$, we have $a + d = 2 \pmod{q^2}$. Since both a and d are bounded in absolute value by T , the number of options for $a + d$ is at most $4T/q^2 + 1$. Similarly, the number of options for a is at most $2T/q + 1$. Therefore, the number of options for (a, d) is $\ll (T/q^2 + 1)(T/q + 1)$.

To determine b, c , note that if $ad \neq 1$, then $bc = 1 - ad \neq 0$, and by standard divisor bounds this gives $\ll_\epsilon T^\epsilon$ options for (b, c) . Otherwise, assuming $q > 2$, $a = d = 1$, and then $b = 0$ or $c = 0$ (or both). If $b = 0$ then c has at most $2T/q + 1$ options, while if $c = 0$, then b has at most $2T/q + 1$ options.

All in all, the number of solution is bounded by

$$\ll_\epsilon (T/q^2 + 1)(T/q + 1)T^\epsilon + T/q + 1 \ll T^\epsilon (T^2/q^3 + T/q + 1). \quad \square$$

Our proof of [Theorem 1.1](#) proceeds with some spectral analysis of hyperbolic surfaces associated to $\mathrm{SL}_2(\mathbb{Z})$ and its congruence subgroups, which will require some preliminaries. Let \mathcal{H} be the hyperbolic plane, with the model $\mathcal{H} = \{z = x + iy \in \mathbb{C} : y > 0\}$. The space \mathcal{H} is equipped with the metric defined by $d(x + iy, x' + iy') = \operatorname{arccosh}(1 + ((x - x')^2 + (y - y')^2)/(2yy'))$ and a measure defined by $dx dy/y^2$. It also has a natural $\mathrm{SL}_2(\mathbb{R})$ action by Möbius transformation, i.e., $\begin{pmatrix} a & b \\ c & d \end{pmatrix} z = (az + b)/(cz + d)$.

This action allows us to identify \mathcal{H} with G/K , where $G = SL_2(\mathbb{R})$, and $K = SO(2)$ is the stabilizer of the point $i \in \mathcal{H}$. We also assume that the Haar measure on G is normalized to agree with the measure on \mathcal{H} on right K -invariant measurable sets.

When using spectral arguments, it will be useful to use a bi- K -invariant (i.e., left and right K -invariant) gauge of largeness of an element. We therefore define $\|g\|_{\mathcal{H}} = e^{d(i,gi)/2}$. Explicitly, by the Cartan decomposition of G , g can be written as

$$g = k_1 \begin{pmatrix} e^{r/2} & \\ & e^{-r/2} \end{pmatrix} k_2,$$

with $k_1, k_2 \in K = SO(2)$, and $r \in \mathbb{R}_{\geq 0}$ unique. Then $\|g\|_{\mathcal{H}} = e^{r/2}$. As the L^2 -norm of the coordinates of γ is $\sqrt{e^r + e^{-r}}$, $\|g\|_{\mathcal{H}}$ is closely related to the infinity norm on the coordinates, namely, there exists a constant $C > 0$ such that $C^{-1}\|g\|_{\infty} \leq \|g\|_{\mathcal{H}} \leq C\|g\|_{\infty}$. We may therefore prove [Theorem 1.1](#) using the gauge $\|\cdot\|_{\mathcal{H}}$ instead of $\|\cdot\|_{\infty}$. Two important properties of $\|\cdot\|_{\mathcal{H}}$ are symmetry $\|g\|_{\mathcal{H}} = \|g^{-1}\|_{\mathcal{H}}$, and submultiplicativity $\|g_1g_2\|_{\mathcal{H}} \leq \|g_1\|_{\mathcal{H}}\|g_2\|_{\mathcal{H}}$. The submultiplicativity follows from the fact that d is a G -invariant metric on \mathcal{H} .

We define the function $\chi_T \in L^1(K \backslash G / K)$ as the normalized probability characteristic function of the set $\{g \in G : \|g\|_{\mathcal{H}} \leq T\}$, i.e.,

$$\chi_T(g) = \frac{1}{2\pi(\cosh(2 \log T) - 1)} \begin{cases} 1 & \text{if } \|g\|_{\mathcal{H}} \leq T, \\ 0 & \text{if } \|g\|_{\mathcal{H}} > T. \end{cases}$$

Notice that $2\pi(\cosh r - 1)$ is the volume of the hyperbolic ball of radius r . Here and later by a probability function we mean a nonnegative function with integral 1.

We also define $\psi_T \in L^1(K \backslash G / K)$ as the function

$$\psi_T(g) = \frac{1}{T} \begin{cases} \|g\|_{\mathcal{H}}^{-1} & \text{if } \|g\|_{\mathcal{H}} \leq T, \\ 0 & \text{if } \|g\|_{\mathcal{H}} > T. \end{cases}$$

There is a convolution of $f \in L^\infty(G/K) \cong L^\infty(\mathcal{H})$ and $\chi \in L^1(K \backslash G / K)$, which we usually think as an action of χ on f . It is simply the convolution of the two functions, when both are considered as invariant functions on G :

$$f * \chi(x) = \int_{g \in G} f(xg^{-1})\chi(g) dg = \int_{g \in G} f(g^{-1})\chi(gx) dg.$$

It holds that $f * \chi \in L^\infty(\mathcal{H})$. For example, the value of $f * \chi_T$ at g_0 , is the average of f over the ball $\{g_0g \in G : \|g\|_{\mathcal{H}} \leq T\}$.

Lemma 2.2 (convolution lemma). *For every $g \in G$, $(\chi_T * \chi_T)(g) \ll \psi_{T^2}(g)$.*

We refer to [\[Sarnak and Xue 1991, Lemma 2.1\]](#) or [\[Gamburd 2002, Proposition 5.1\]](#) for a proof. Geometrically, the proof calculates the volume of an intersection of two hyperbolic balls. In [Lemma 4.2](#) we give a spectral proof of a similar statement for $SL_3(\mathbb{R})$, which also works for $SL_2(\mathbb{R})$, but adds a factor that is logarithmic in T .

As in the statement [Theorem 1.1](#), let $q \in \mathbb{Z}_{>0}$, $\Gamma = \mathrm{SL}_2(\mathbb{Z})$, $G_q = \mathrm{SL}_2(\mathbb{Z}/q\mathbb{Z})$ and let $\pi_q : \Gamma \rightarrow G_q$ be the quotient map. Let $\Gamma(q) = \ker \pi_q$.

We look at the locally symmetric space $X_q := \Gamma(q) \backslash \mathcal{H} \cong \Gamma \backslash G/K$. This space is a hyperbolic orbifold of finite volume. By $L^2(X_q)$ we mean the Hilbert space of measurable functions on X_q with bounded L^2 -norm relative to the finite measure on X_q , with the obvious inner-product. We still consider a function on $X_q = \Gamma(q) \backslash \mathcal{H} = \Gamma(q) \backslash G/K$ as a left $\Gamma(q)$ -invariant function on \mathcal{H} or on G . Right convolution by functions from $L^1(K \backslash G/K)$ is defined for bounded functions on X_q , and extends to functions in $L^2(X_q)$ as the convolution defines a bounded operator. In particular, we will consider right convolution of $f \in L^2(X_q)$ with χ_T .

For $x_0 \in X_q$, denote $b_{T,x_0}(x) := \sum_{\gamma \in \Gamma(q)} \chi_T(\tilde{x}_0^{-1} \gamma x)$, when \tilde{x}_0 is any lift of x_0 to G . It holds that $b_{T,x_0} \in L^2(X_q)$, and $\int_{X_q} b_{T,x_0}(x) dx = 1$.

In particular $b_{T,e}$ corresponds to the point $\Gamma(q)eK \in \Gamma(q) \backslash \mathcal{H}$, where e is the identity matrix in G .

Lemma 2.3. *For $f \in L^2(X_q)$ bounded,*

$$\langle f, b_{T,x_0} \rangle = f * \chi_T(x_0).$$

Proof. By unfolding,

$$\begin{aligned} \langle f, b_{T,x_0} \rangle &= \int_{x \in \Gamma(q) \backslash \mathcal{H}} f(x) \sum_{\gamma \in \Gamma(q)} \chi_T(x_0^{-1} \gamma x) dx \\ &= \int_{x \in \Gamma(q) \backslash \mathcal{H}} \sum_{\gamma \in \Gamma(q)} f(\gamma x) \chi_T(x_0^{-1} \gamma x) dx \\ &= \int_{x \in \mathcal{H}} f(x) \chi_T(x_0^{-1} x) dx \\ &= \int_{x \in \mathcal{H}} f(x) \chi_T(x^{-1} x_0) dx \\ &= f * \chi_T(x_0). \end{aligned}$$

Notice that we used the fact that $\chi_T(g) = \chi_T(g^{-1})$, which is a simplification that will not occur in SL_3 . \square

The following lemma uses the combinatorial [Lemma 2.1](#) to get analytic information:

Lemma 2.4. *It holds that*

$$\|b_{T,e}\|_2^2 \ll_\epsilon T^\epsilon \left(\frac{1}{q^3} + \frac{1}{T^2} \right).$$

In particular, for $T = q^{3/2}$,

$$\|b_{T,e}\|_2^2 \ll_\epsilon \frac{T^\epsilon}{q^3}.$$

Proof. By [Lemmas 2.3](#) and [2.2](#),

$$\|b_{T,e}\|_2^2 = b_{T,e} * \chi_T(e) = \sum_{\gamma \in \Gamma(q)} (\chi_T * \chi_T)(\gamma) \ll \sum_{\gamma \in \Gamma(q)} \psi_{T^2}(\gamma) = \frac{1}{T^2} \sum_{\gamma \in \Gamma(q) : \|\gamma\|_{\mathcal{H}} \leq T^2} \|\gamma\|_{\mathcal{H}}^{-1}.$$

We next apply discrete partial summation [Hardy and Wright 1979, Theorem 421] which says that for $g : \Gamma(q) \rightarrow [1, \infty]$, $f : [1, \infty] \rightarrow \mathbb{R}$ nice enough it holds that

$$\sum_{\gamma:1 \leq g(\gamma) \leq Y} f(g(\gamma)) = f(Y) |\{\gamma : 1 \leq g(\gamma) \leq Y\}| - \int_1^Y |\{\gamma : g(\gamma) \leq S\}| \frac{df}{dS}(S) dS. \tag{2-1}$$

Apply this to $g(\gamma) = \|\gamma\|_{\mathfrak{H}}$, $f(x) = x^{-1}$ and $Y = T^2$,

$$\begin{aligned} \frac{1}{T^2} \sum_{\gamma \in \Gamma(q) : \|\gamma\|_{\mathfrak{H}} \leq T^2} \|\gamma\|_{\mathfrak{H}}^{-1} &= \frac{1}{T^2} \left(\frac{1}{T^2} |\{\gamma \in \Gamma(q) : \|\gamma\|_{\mathfrak{H}} \leq T^2\}| + \int_1^{T^2} |\{\gamma \in \Gamma(q) : \|\gamma\|_{\mathfrak{H}} \leq S\}| S^{-2} dS \right) \\ &\ll_{\epsilon} T^{\epsilon} \frac{1}{T^2} \left(\frac{1}{T^2} \left(\frac{T^4}{q^3} + \frac{T^2}{q} + 1 \right) + \int_1^{T^2} \frac{1}{S^2} \left(\frac{S^2}{q^3} + \frac{S}{q} + 1 \right) dS \right) \\ &\ll_{\epsilon} T^{\epsilon} \frac{1}{T^2} \left(\frac{T^2}{q^3} + \frac{1}{q} + \frac{1}{T^2} + 1 \right) \\ &\ll T^{\epsilon} \left(\frac{1}{q^3} + \frac{1}{T^2} \right). \end{aligned}$$

The first inequality follows from Lemma 2.1. □

Let $\pi \in L^2(X_q)$ be the constant probability function on X_q (recall that the space has finite volume). Denote by $L_0^2(X_q)$ the set of functions of integral 0, or alternatively the set of functions orthogonal to π . The deepest input to the proof is the following celebrated theorem of Selberg:

Theorem 2.5 (Selberg’s spectral gap theorem). *There is an explicit $\tau > 0$ such that for every $f \in L_0^2(X_q)$ and $T > 0$ it holds that $\|f * \chi_{T\eta}\|_2 \ll T^{-\eta\tau} \|f\|_2$.*

Selberg’s theorem is usually stated as a lower bound on the spectrum of the Laplacian. However, it is well known that it can be translated to a spectral gap of the convolution operators by large balls. The statement is true in great generality (see, e.g., [Ghosh et al. 2013, Section 4]), but for the benefit of the reader we give a sketch of the proof, based on [Golubev and Kamber 2019]. For $r \geq 0$ we define an operator

$$A_r : L^2(X_q) \rightarrow L^2(X_q),$$

by

$$A_r f(x) = \int_K \int_K f \left(x k_1 \begin{pmatrix} e^{r/2} & 0 \\ 0 & e^{-r/2} \end{pmatrix} k_2 \right) dk_1 dk_2.$$

By [Golubev and Kamber 2019, Proposition 7.2] (or alternatively, by bounds on Harish-Chandra’s function for $SL_2(\mathbb{R})$), if the smallest nonzero eigenvalue of the Laplacian Δ on $L^2(X_q)$ is larger than $\frac{1}{4} - (\frac{1}{2} - p^{-1})^2$, then for every $f \in L_0^2(X_q)$ it holds that

$$\|A_r f\|_2 \leq (r + 1) e^{-r/p} \|f\|_2.$$

Selberg’s spectral gap theorem says that the smallest nontrivial eigenvalue of the Laplacian is at least $\frac{3}{16}$, so the above holds with $p = 4$. There are various results improving the value of p in Selberg’s

theorem (see [Sarnak 2005]), and the best one is due to Kim and Sarnak, giving $p = \frac{64}{25}$. However, those improvements are inconsequential for us. In any case, by comparing the definition, we see that

$$f * \chi_T(x) = \frac{1}{2\pi \cosh(2 \log T) - 1} \int_0^{2 \log T} 2\pi \sinh r (A_r f)(x) dr,$$

and therefore

$$\begin{aligned} \|f * \chi_T\|_2 &\leq \frac{1}{2\pi \cosh(2 \log T) - 1} \int_0^{2 \log T} 2\pi \sinh r \|A_r f\|_2 dr \\ &\leq \frac{\|f\|_2}{\cosh(2 \log T) - 1} \int_0^{2 \log T} (r + 1)e^{r(1-1/4)} dr \\ &\leq \frac{2(\log T + 1)^2 T^{2(1-1/4)} \|f\|_2}{\cosh(2 \log T) - 1}. \end{aligned}$$

For T large enough the above is

$$\ll T^{-2/5} \|f\|_2,$$

which give us the needed result, with $\tau = \frac{2}{5}$. The Kim–Sarnak bounds allows us to take $\tau = \frac{32}{25} + \epsilon$ for any $\epsilon > 0$.

The important part of the theorem is the independence of τ from q . We fix this $\tau > 0$ for the rest of this section.

From Selberg’s theorem we deduce:

Lemma 2.6. *For $T = q^{3/2}$, and every $\epsilon > 0$*

$$\|b_{T,e} * \chi_{T^\eta} - \pi\|_2 \ll_\epsilon q^{-3/2 - \eta\tau + \epsilon}.$$

Proof. We have $b_{T,e} - \pi \in L_0^2(X_q)$ and $\pi * \chi_T = \pi$ (as an average of the constant function is the constant function).

Therefore,

$$\|b_{T,e} * \chi_{T^\eta} - \pi\|_2 = \|(b_{T,e} - \pi) * \chi_{T^\eta}\|_2 \ll T^{-\eta\tau} \|b_{T,e} - \pi\|_2 \ll_\epsilon q^{-3/2 - \eta\tau + \epsilon},$$

where in the first inequality we applied [Theorem 2.5](#), and in the second inequality we applied $\|b_{T,e} - \pi\|_2 \leq \|b_{T,e}\|_2$ ($b_{T,e} - \pi$ is the orthogonal projection of $b_{T,e}$ onto $L_0^2(X_q)$) and [Lemma 2.4](#). □

The last lemma implies that the function $b_{T,e} * \chi_{T^\eta}$ is very close to the constant probability function π . Let us show how this implies [Theorem 1.1](#).

We have a map $\iota: G_q \cong \Gamma(q) \backslash \Gamma \rightarrow X_q \cong \Gamma(q) \backslash G/K$, defined as $\iota(\Gamma(q)\gamma) = \Gamma(q)\gamma K$. For $y \in G_q$, we may consider the function $b_{T_0, \iota(y)}$. We choose T_0 small enough (independently of q), so that the functions $b_{T_0, \iota(y)}$ will have disjoint supports for $\iota(y) \neq \iota(y')$. Specifically, it is enough to choose T_0 such that the ball of radius $2 \log T_0$ around i and around $\gamma i \neq i$ for $\gamma \in \text{SL}_2(\mathbb{Z})$ are disjoint. We also notice that ι has fibers of bounded size, specifically $|\text{SL}_2(\mathbb{Z}) \cap K| = 4$. This implies that for every $\iota(y)$, $x \in X_q$,

identified with some lifts \tilde{y}, \tilde{x} to $SL_2(\mathbb{R})$, there are at most 4 element $\gamma \in \Gamma(q)$ such that $\chi_{T_0}(\tilde{y}^{-1}\gamma\tilde{x}) \neq 0$. Therefore,

$$\|b_{T_0, \iota(y)}\|_2^2 \leq 16\|\chi_{T_0}\|_2^2.$$

In particular, $\|b_{T_0, \iota(y)}\|_2$ is bounded uniformly in q .

Lemma 2.7. *Assume that $\langle b_{T,e} * \chi_{T^\eta}, b_{T_0, \iota(y)} \rangle > 0$. Then there exists $\gamma \in \Gamma$ such that $\pi_q(\gamma) = y$, and $\|\gamma\|_{\mathcal{H}} \leq T_0 T^{1+\eta}$.*

Proof. By Lemma 2.3, the condition implies that

$$\langle b_{T,e} * \chi_{T^\eta} * \chi_{T_0}, \iota(y) \rangle > 0.$$

Treat the function as a left $\Gamma(q)$ -invariant and right K -invariant function on G . Let γ_y be a lift of y to Γ , i.e., $\pi_q(\gamma_y) = y$. Therefore, $b_{T,e} * \chi_{T^\eta} * \chi_{T_0}(\gamma_y) > 0$.

By the definition of convolution, there are $g'_1, g_2, g_3 \in G$, such that $g'_1 \in \text{supp}(b_{T,e})$, $g_2 \in \text{supp}(\chi_{T^\eta})$, $g_3 \in \text{supp}(\chi_{T_0})$, and such that $g'_1 g_2 g_3 = \gamma_y$. Looking at the definition of $b_{T,e}$ and g'_1 , there are $g_1 \in \text{supp}(\chi_T)$, $\gamma \in \Gamma(q)$ such that $e^{-1}\gamma g'_1 = g_1$ (we write e for the identity element instead of discarding it, anticipating the case of SL_3 below). Therefore $\gamma^{-1} e g_1 g_2 g_3 = \gamma_y$.

Write $g = g_1 g_2 g_3$. By the above, $\|g\|_{\mathcal{H}} \leq \|g_1\|_{\mathcal{H}} \|g_2\|_{\mathcal{H}} \|g_3\|_{\mathcal{H}} \leq T_0 T^{1+\eta}$. In addition, $eg = \gamma \gamma_y$, so that $g \in \Gamma(q)\gamma_y$. Therefore $g \in \Gamma$ and $\pi_q(g) = y$, as needed. \square

We may now finish the proof of Theorem 1.1. Let $\eta > 0$ and write $T = q^{3/2}$. Assume that $Z \subset G_q$ is the set of $y \in G_q$ such that there is no $\gamma_y \in \Gamma$ with $\|\gamma_y\|_{\mathcal{H}} \leq T_0 T^{1+\eta}$ and $\pi_q(\gamma_y) = y$. It suffices to prove that for a fixed $\eta > 0$ it holds that $|Z| = o_\eta(q^3)$.

By Lemma 2.7, for every $y \in Z$,

$$\langle b_{T,e} * \chi_{T^\eta}, b_{T_0, \iota(y)} \rangle = 0.$$

Let $B = \sum_{y \in Z} b_{T_0, \iota(y)}$. Then by the above and the fact that $\langle \pi, b_{T_0, \iota(y)} \rangle = 1/\text{Vol}(\Gamma(q)\backslash\mathcal{H}) \gg 1/q^3$,

$$|\langle b_{T,e} * \chi_{T^\eta} - \pi, B \rangle| \gg \frac{|Z|}{q^3}.$$

On the other hand, by the choice of T_0 and the remarks following it, $\|B\|_2^2 \ll |Z|$. Therefore, using Lemma 2.6 and Cauchy-Schwarz,

$$|\langle b_{T,e} * \chi_{T^\eta} - \pi, B \rangle| \ll \|B\|_2 \|b_{T,e} * \chi_{T^\eta} - \pi\|_2 \ll_\epsilon \sqrt{|Z|} q^{-3/2-\eta\tau+\epsilon}.$$

Combining the two estimates and taking $\epsilon = \eta\tau/2$ gives

$$|Z| \ll_\eta q^{3-\eta\tau} = o_\eta(q^3),$$

as needed.

3. Proof of Theorem 1.4

Our goal is to prove that there exists a constant $C > 0$ such that for every prime q , $\epsilon > 0$ and $T \leq Cq^2$, we have

$$|\{(\gamma, x) \in \text{SL}_3(\mathbb{Z}) \times P^2(\mathbb{F}_q) : \|\gamma\|_\infty \|\gamma^{-1}\|_\infty \leq T, \Phi_q(\gamma)x = x\}| \ll_\epsilon Tq^{2+\epsilon}.$$

If $\gamma \pmod q$ has no eigenspace of dimension 2 or 3, then it has at most 3 eigenvectors in $P^2(\mathbb{F}_q)$. Call such a γ *good* mod q and otherwise call it *bad* mod q . Recall that the number of $\gamma \in \text{SL}_3(\mathbb{Z})$ such that $\|\gamma\|_\infty \|\gamma^{-1}\|_\infty \leq T$ is bounded up to a constant by the measure of the corresponding set in $\text{SL}_3(\mathbb{R})$ [Duke et al. 1993; Maucourant 2007], which is bounded for every $\epsilon > 0$ by $T^{2+\epsilon}$ [Maucourant 2007]; see also (4-3). Therefore, for $T \leq q^2$,

$$\begin{aligned} |\{(\gamma, x) \in \text{SL}_3(\mathbb{Z}) \times P^2(\mathbb{F}_q) : \|\gamma\|_\infty \|\gamma^{-1}\|_\infty \leq T, \Phi_q(\gamma)x = x, \gamma \text{ good mod } q\}| \\ \ll |\{\gamma \in \text{SL}_3(\mathbb{Z}) : \|\gamma\|_\infty \|\gamma^{-1}\|_\infty \leq T\}| \ll T^{2+\epsilon} \ll Tq^{2+\epsilon}. \end{aligned}$$

We therefore restrict to the case of bad γ -s. Notice that bad elements do exist and may have a lot of fixed points: e.g., the element $I \in \text{SL}_3(\mathbb{Z})$ is bad mod q and $\Phi_q(I)$ fixes all of $P^2(\mathbb{F}_q)$. There are two types of bad elements:

- Elements $\gamma \in \text{SL}_3(\mathbb{Z})$ such that $\Phi_q(\gamma) = \alpha I_{\text{SL}_3(\mathbb{F}_q)}$, for $\alpha \in \mathbb{F}_q$, $\alpha^3 = 1$. Such elements will fix the entire space $P^2(\mathbb{F}_q)$.
- In any other case, $\Phi_q(\gamma)$ will have one eigenspace of dimension 2, and possibly another eigenspace of dimension 1. Thus $\Phi_q(\gamma)$ fixes at most $q + 1 + 1$ elements in $P^2(\mathbb{F}_q)$.

Assuming that we choose $C < \frac{1}{4}$, it will hold that either $\|\gamma\|_\infty < q/2$ or $\|\gamma^{-1}\|_\infty < q/2$. On the other hand, if $\gamma \neq I$ and $\Phi_q(\gamma) = \alpha I_{\text{SL}_3(\mathbb{F}_q)}$, then γ and γ^{-1} will have a nonzero entry divisible by q , which is a contradiction. Therefore, we may assume that for each bad γ , $\Phi_q(\gamma)$ will fix at most $q + 1$ elements in $P^2(\mathbb{F}_q)$.

It thus suffices to prove that for some $C > 0$, and $T \leq Cq^2$,

$$|\{\gamma \in \text{SL}_3(\mathbb{Z}) : \|\gamma\|_\infty \|\gamma^{-1}\|_\infty \leq T, \gamma \text{ bad mod } q\}| \ll_\epsilon Tq^{1+\epsilon}.$$

Assume that γ is bad mod q and $\|\gamma\|_\infty \|\gamma^{-1}\|_\infty \leq T$. Without loss of generality assume that $\|\gamma\|_\infty \leq \|\gamma^{-1}\|_\infty \leq T^{1/2} < q/2$. We identify elements of \mathbb{F}_q with integers of absolute value at most $q/2$. Thus, once we know the value of an entry of $\gamma \pmod q$ we know the same entry in γ .

We divide the range of $\|\gamma\|_\infty$ into $O(\log T)$ dyadic subintervals. Denote by S the bound on $\|\gamma\|_\infty$ and by R the bound on $\|\gamma^{-1}\|_\infty$. Then it is enough to prove that there exists $C > 0$ such that for every $RS \leq Cq^2$ and $S \leq R$ it holds that

$$|\{\gamma \in \text{SL}_3(\mathbb{Z}) : \|\gamma\|_\infty \leq S, \|\gamma^{-1}\|_\infty \leq R, \gamma \text{ bad mod } q\}| \ll_\epsilon RSq^{1+\epsilon}.$$

It will be useful to understand the behavior of bad γ . Let $\alpha \in \mathbb{F}_q \setminus \{0\}$ be the eigenvalue of $\gamma \pmod q$ with an eigenspace of dimension 2. Then the third eigenvalue is $\alpha^{-2} \pmod q$.

From this it follows that $(\gamma - \alpha I)(\gamma - \alpha^{-2}I) = 0 \pmod q$, or,

$$\gamma + \alpha^{-1}\gamma^{-1} = \alpha + \alpha^{-2} \pmod q. \tag{3-1}$$

By considering the trace of γ and γ^{-1} we have that

$$\text{tr } \gamma = \alpha + 2\alpha^{-2} \pmod q, \quad \text{tr } \gamma^{-1} = \alpha^{-1} + 2\alpha^2 \pmod q. \tag{3-2}$$

Finally, identify α with some lift of it in \mathbb{Z} . Then $\gamma - \alpha I \pmod q$ is of rank 1, which means that $\det(\gamma - \alpha I) = 0 \pmod{q^2}$. Since $\det \gamma = 1$, we have

$$\det(\gamma - xI) = 1 - \text{tr } \gamma^{-1}x + \text{tr } \gamma x^2 - x^3,$$

and hence

$$\alpha^2 \text{tr } \gamma - \alpha \text{tr } \gamma^{-1} = \alpha^3 - 1 \pmod{q^2}. \tag{3-3}$$

Denote the entries of γ by a_{ij} , $1 \leq i, j \leq 3$ and the entries of γ^{-1} by b_{ij} , $1 \leq i, j \leq 3$.

There are $\leq (2S + 1)^3$ options for choosing the diagonal a_{11}, a_{22}, a_{33} of γ , and once we know them, we know $\text{tr } \gamma$. By (3-2) α (when considered as an element of \mathbb{F}_q) is a root of a known third degree polynomial, so there are at most 3 options for α . By (3-3) we know $\text{tr } \gamma^{-1} \pmod{q^2}$. Since $R \leq RS \leq Cq^2 < q^2/4$, we may assume that $|\text{tr } \gamma^{-1}| < q^2/2$, so now we know $\text{tr } \gamma^{-1}$.

By (3-1) we now know the diagonal $b_{11}, b_{22}, b_{33} \pmod q$ of $\gamma^{-1} \pmod q$. Since the entries b_{11}, b_{22}, b_{33} are bounded in absolute value by R , we have at most $2R/q + 1$ options for each of them. We may guess b_{11}, b_{22} and get b_{33} since we know $\text{tr } \gamma^{-1}$.

In total, we had $\ll S^3(R/q + 1)^2$ options so far. We call the case where $a_{ii}a_{jj} = b_{kk}$ for some $\{i, j, k\} = \{1, 2, 3\}$ exceptional. We will deal with it later and assume for now that we are in the nonexceptional case.

Notice that $a_{11}a_{22} - a_{12}a_{21} = b_{33}$, or

$$a_{12}a_{21} = a_{11}a_{22} - b_{33}.$$

Since we are in the nonexceptional case, the right hand side is not 0. By the divisor bound there are at most $\ll_{\epsilon} q^{\epsilon}$ options for a_{12}, a_{21} . Similarly, all the other entries $a_{13}, a_{31}, a_{23}, a_{32}$ have at most $\ll_{\epsilon} q^{\epsilon}$ options.

In total, we counted $\ll_{\epsilon} q^{\epsilon} S^3(R/q + 1)^2$ bad γ -s in the nonexceptional case. We postpone the exceptional case to the end of the proof. The same (and better) bounds hold for it as well.

It remains to show that

$$S^3(R/q + 1)^2 \ll RSq,$$

assuming $S \leq R, RS \leq Cq^2$.

If $R \leq q$, then we need to show that $S^3 \ll RSq$, or $S^2 \ll Rq$, which is obvious since $S \leq R \leq q$.

If $R > q$ then we need to show that $S^3 R^2/q^2 \ll RSq$, or $S^2 R \ll q^3$. Since $RS \leq Cq^2$, this reduces to showing that $S \ll q$, which is obvious since $S^2 \leq RS \leq Cq^2$.

Exceptional cases. Recall that the exceptional case is when $a_{ii}a_{jj} = b_{kk}$ for some $\{i, j, k\} = \{1, 2, 3\}$. Assume without loss of generality that $a_{11}a_{22} = b_{33}$. Therefore $a_{12}a_{21} = a_{11}a_{22} - b_{33} = 0$.

We know that $\gamma - \alpha I \pmod q$ is of rank 1, so each determinant of a 2×2 submatrix of γ equals 0 mod q . Therefore

$$(a_{11} - \alpha)(a_{22} - \alpha) - a_{12}a_{21} = 0 \pmod q,$$

so

$$(a_{11} - \alpha)(a_{22} - \alpha) = 0 \pmod q.$$

Without loss of generality again, we may assume that $a_{11} = \alpha \pmod q$. By our assumptions on the size of the matrix, we may lift α to some fixed element in \mathbb{Z} of absolute value $\leq q/2$ and let $a_{11} = \alpha$. By the above, $a_{12}a_{21} = 0$, and by symmetry again, we may assume that $a_{21} = 0$. Some more minors give:

$$a_{31}(a_{22} - \alpha) = a_{21}a_{32} = 0 \pmod q. \quad (3-4)$$

$$a_{31}a_{23} = a_{21}(a_{33} - \alpha) = 0 \pmod q. \quad (3-5)$$

We now divide into two cases according to whether $a_{31} = 0$:

Case 1 $a_{11} = \alpha, a_{21} = 0, a_{31} = 0$. In this case, the matrix is of the form

$$\gamma = \begin{pmatrix} \alpha & a_{12} & a_{13} \\ 0 & a_{22} & a_{23} \\ 0 & a_{32} & a_{33} \end{pmatrix}.$$

Denote $A = \begin{pmatrix} a_{22} & a_{23} \\ a_{32} & a_{33} \end{pmatrix}$. It holds that $\alpha \det A = 1$. Therefore $\alpha = \pm 1$ and $\det A = \pm 1$. We also know that the eigenvalues of $A \pmod q$ are either ± 1 (if $\alpha = -1$) or 1 with multiplicity 2 (if $\alpha = 1$). Therefore the trace of A is either 0 or 2. We now separate into two further cases. In the first case $a_{22} \neq \alpha$ and $a_{33} \neq \alpha$, or equivalently $a_{22}a_{33} \neq \det A$. In the second case we may assume without loss of generality that $a_{22} = \alpha$.

Case 1a $a_{11} = \alpha, a_{21} = 0, a_{31} = 0, a_{22} \neq \alpha, a_{33} \neq \alpha$. The entry a_{22} has $2S + 1$ options, and it determines the value of a_{33} since we know the trace of A . In this subcase it holds that $a_{23}a_{32} = \det A - a_{22}a_{33} \neq 0$. By the divisor bound there are $\ll_{\epsilon} S^{\epsilon}$ options for a_{23}, a_{32} and both are nonzero. We also know that the third column of $\gamma - \alpha I \pmod q$ is a multiple of the second column, and now we know the ratio. This means that after we choose a_{12} in $2S + 1$ ways it sets a_{13} uniquely. Therefore there are $\ll_{\epsilon} S^{2+\epsilon} \leq RSq^{\epsilon}$ options in this case.

Case 1b $a_{11} = \alpha, a_{21} = 0, a_{31} = 0, a_{22} = \alpha, a_{33} = 1$. In this case $a_{23}a_{32} = \det A - a_{22}a_{33} = 0$. If $a_{23} \neq 0$ then $a_{32} = a_{12} = 0$ and there are $\leq (2S + 1)^2$ options for a_{23}, a_{13} . Similarly, if $a_{32} \neq 0$ then $a_{23} = 0$ and once we know a_{12} we also know a_{13} . Therefore there are $\ll S^2 \leq RS$ option in this case.

Case 2 $a_{11} = \alpha, a_{21} = 0, a_{31} \neq 0$. By (3-4), (3-5) we have $a_{22} = \alpha, a_{23} = 0$, and hence

$$\gamma - \alpha I = \begin{pmatrix} 0 & a_{12} & a_{13} \\ 0 & 0 & 0 \\ a_{31} & a_{32} & a_{33} - \alpha \end{pmatrix}$$

Since its rank mod q is 1 and $a_{31} \neq 0$ the second and third columns are scalar multiples of the first, thus $a_{12} = a_{13} = 0$. Therefore γ is of the form

$$\gamma = \begin{pmatrix} \alpha & 0 & 0 \\ 0 & \alpha & 0 \\ a_{31} & a_{32} & a_{33} \end{pmatrix}.$$

Since $\det \gamma = 1$ it holds that $\alpha = \pm 1$, $a_{33} = 1$ and there are $\ll S^2 \leq RS$ options for γ .

4. Proof of Theorem 1.3

As in the proof of Theorem 1.1, the proof of Theorem 1.3 is analytic, and employs the combinatorial Theorem 1.4 as an input. Since we wish to use the usual notations of dividing $SL_3(\mathbb{R})$ by $SL_3(\mathbb{Z})$ from the left, we apply a transpose to the question as stated in Theorem 1.3.

Let

$$\Gamma_0(q) = \left\{ \begin{pmatrix} * & * & * \\ * & * & * \\ a & b & * \end{pmatrix} \in SL_3(\mathbb{Z}) : a = b = 0 \pmod q \right\}.$$

We have a right action of $\Gamma = SL_3(\mathbb{Z})$ on $\Gamma_0(q)$. We let $P_q^{tr} = \Gamma_0(q) \backslash \Gamma$ (it is obviously isomorphic to P_q as a set with a Γ action). Then Theorem 1.3 can be stated in the following equivalent formulation:

Theorem 4.1. *As $q \rightarrow \infty$ among primes, for every $\epsilon > 0$ there exists a set $Y \subset \Gamma_0(q) \backslash \Gamma = P_q^{tr}$ of size $|Y| \geq (1 - o_\epsilon(1)) |P_q^{tr}|$, such that for every $x_0 \in Y$, there exists a set $Z_{x_0} \subset P_q^{tr}$ of size $|Z_{x_0}| \geq (1 - o_\epsilon(1)) |P_q^{tr}|$, such that for every $y \in Z_{x_0}$, there exists an element $\gamma \in \Gamma$ satisfying $\|\gamma\|_\infty \leq q^{1/3+\epsilon}$, such that $x_0\gamma = y$.*

Let $K = SO(3)$ be the maximal compact subgroup of $G = SL_3(\mathbb{R})$. By the Cartan decomposition each element $g \in G$ can be written as

$$g = k_1 \begin{pmatrix} a_1 & & \\ & a_2 & \\ & & a_3 \end{pmatrix} k_2,$$

with $k_1, k_2 \in SO(3)$, and unique $a_1, a_2, a_3 \in \mathbb{R}_{>0}$, satisfying $a_1 \geq a_2 \geq a_3 > 0$ and $a_1 a_2 a_3 = 1$. Define $\|g\|_K = a_1$. Since $K = SO(3)$ is compact there exists a constant $C > 0$ such that

$$C^{-1} \|g\|_\infty \leq \|g\|_K \leq C \|g\|_\infty.$$

We may therefore prove Theorem 4.1 using $\|\cdot\|_K$ instead of $\|\cdot\|_\infty$.

The size $\|\cdot\|_K$ will play the same role as $\|\cdot\|_{\mathcal{H}}$ in the SL_2 case. Let us note some of its properties. There is a constant $C > 0$ such that $\|g_1 g_2\|_K \leq C \|g_1\|_K \|g_2\|_K$ (actually, one may take $C = 1$, but this detail will not influence us). A big difference from the SL_2 case comes from the fact that $\|\gamma\|_K$ and $\|\gamma^{-1}\|_K$ can be quite different. However, it does hold that $\|\gamma\|_K \ll \|\gamma^{-1}\|_K^2$.

It will also be useful to define another bi- K invariant gauge of largeness, by $\|g\|_\delta = a_1 a_3^{-1}$, where a_1, a_3 are as in the Cartan decomposition. It holds that there is a constant $C > 0$ such that

$$C^{-1} \|g\|_\infty \|g^{-1}\|_\infty \leq \|g\|_\delta \leq C \|g\|_\infty \|g^{-1}\|_\infty. \tag{4-1}$$

Now we have $\|g\|_\delta = \|g^{-1}\|_\delta$, and there is $C > 0$ (which may be chosen to be $C = 1$ by extra analysis) such that $\|g_1 g_2\|_\delta \leq C \|g_1\|_\delta \|g_2\|_\delta$.

The relation between the two sizes is that $\|g\|_\delta \leq \|g\|_K^3$, which follows from the fact that in the Cartan decomposition $a_3^{-1} = a_1 a_2 \leq a_1^2$, so $a_1 a_3^{-1} \leq a_1^3$.

We will want to estimate the size of balls relative to $\|\cdot\|_K$ and $\|\cdot\|_\delta$. For this, we use the following formula for the Haar measure μ of G [Knapp 1986, Proposition 5.28], which holds up to multiplication by a scalar $C > 0$:

$$\int_G f(g) d\mu = C \int_K \int_K \int_{\mathfrak{a}_+} f(k \exp(a) k') S(a) dk dk' da,$$

where

$$\mathfrak{a}_+ = \left\{ a = \begin{pmatrix} \alpha_1 & & \\ & \alpha_2 & \\ & & \alpha_3 \end{pmatrix} \in M_3(\mathbb{R}) : \alpha_1 \geq \alpha_2 \geq \alpha_3, \alpha_1 + \alpha_2 + \alpha_3 = 0 \right\},$$

and

$$S(a) = \sinh(\alpha_1 - \alpha_2) \sinh(\alpha_2 - \alpha_3) \sinh(\alpha_3 - \alpha_1).$$

Notice that for $\alpha_1 - \alpha_2 \geq 1, \alpha_2 - \alpha_3 \geq 1$, $S(a)$ behaves like $\|a\|_\delta^2$. This implies that

$$\mu(\{g \in G : \|g\|_K \leq T\}) \asymp T^6, \tag{4-2}$$

and

$$\mu(\{g \in G : \|g\|_\delta \leq T\}) \asymp \log(T) T^2. \tag{4-3}$$

For completeness let us explain the calculation of (4-3), the calculation for (4-2) is similar; see [Maucourant 2007; Gorodnik and Weiss 2007] for more accurate and general statements. To simplify notations we identify $a \in \mathfrak{a}_+$ with $a = (\alpha_1, \alpha_2, \alpha_3) \in \mathbb{R}^3$. The condition $a_1 a_3^{-1} \leq T$ translates under the inverse of the exponential map and the Cartan decomposition to $\alpha_1 - \alpha_3 \leq \log T$. Denote

$$B(T) = \{a \in \mathfrak{a}_+ : \alpha_1 - \alpha_3 \leq \log T\}$$

Since $\{g \in G : \|g\|_\delta \leq T\} = K \exp(B(T))K$,

$$\mu(\{g \in G : \|g\|_\delta \leq T\}) = \int_{a \in B(T)} S(a) da.$$

Let us parametrize the set $B(T)$ by looking at the vectors $v_1 = (1, -1, 0), v_2 = (-1, 2, -1)$. Then $B(T) = \{s v_1 + t v_2 : 0 \leq s \leq \frac{1}{2} \log T, 0 \leq t \leq s/2\}$. We therefore get

$$\mu(\{g \in G : \|g\|_\delta \leq T\}) = \int_0^{\frac{1}{2} \log T} \int_0^{s/2} \sinh(2s - 3t) \sinh(3t) \sinh(2s) dt ds.$$

Using the upper bound $\sinh x \leq e^x$, the above is upper bounded by

$$\leq \int_0^{\frac{1}{2} \log T} \int_0^{s/2} e^{4s} dt ds \leq \int_0^{\frac{1}{2} \log T} s e^{4s} / 2 ds \ll \log(T) T^2.$$

Using the lower bound $\sinh x \geq e^x / 4$ for $x \geq 1$, we get the lower bound

$$\geq \int_{\frac{1}{2} \log T - 1}^{\frac{1}{2} \log T} \int_1^{s/2 - 1} e^{4s} dt ds \gg \log(T) T^2.$$

Let $\chi_T, \chi_{T,\delta} \in L^1(K \backslash G / K)$ be

$$\chi_T(g) = \frac{1}{\mu(\{g \in G : \|g\|_K \leq T\})} \begin{cases} 1 & \|g\|_K \leq T, \\ 0 & \text{else,} \end{cases} \quad \chi_{T,\delta}(g) = \frac{1}{\mu(\{g \in G : \|g\|_\delta \leq T\})} \begin{cases} 1 & \|g\|_\delta \leq T, \\ 0 & \text{else.} \end{cases}$$

The functions $\chi_T, \chi_{T,\delta}$ are simply the probability characteristic functions of the balls according to $\|\cdot\|_K$ and $\|\cdot\|_\delta$.

By (4-2), (4-3) and the definition of $\|\cdot\|_K, \|\cdot\|_\delta$, for every $g \in G$,

$$\chi_T(g) \gg \log T \chi_{T^3,\delta}(g).$$

Let $\psi_T : G \rightarrow \mathbb{R}$ be

$$\psi_T(g) = \frac{1}{T} \begin{cases} \|g\|_\delta^{-1} & \|g\|_\delta \leq T, \\ 0 & \text{else.} \end{cases}$$

For $f : G \rightarrow \mathbb{C}$, we let $f^* : G \rightarrow \mathbb{C}$ be the function $f^*(g) = \overline{f(g^{-1})}$.

Now we have the following version of Lemma 2.2:

Lemma 4.2 (convolution lemma). *There exists a constant $C > 0$ such that for $T \geq 1$*

$$\chi_{T,\delta} * \chi_{T,\delta}(g) \leq (\log T + 2)^C \psi_{CT^2}(g).$$

As a result, there exist a constant $C' > 0$ such that for $T \geq 1$

$$\chi_T * \chi_T^* \leq (\log T + 2)^{C'} \psi_{C'T^6}(g).$$

Proof. Normalize K to have measure 1. Let $\Xi : G \rightarrow \mathbb{R}_+$ be Harish-Chandra's function, defined as

$$\Xi(g) = \int_K \delta^{-1/2}(gk) dk,$$

where $\delta : G \rightarrow \mathbb{R}_{>0}$ is defined, using the Iwasawa decomposition $G = KP$, as

$$\delta \left(k \begin{pmatrix} a_1 & * & * \\ 0 & a_2 & * \\ 0 & 0 & a_3 \end{pmatrix} \right) = a_1^2 a_3^{-2}.$$

(When restricted to P , δ is the modular function of P . Notice the similarity between $\delta(g)$ and $\|g\|_\delta^2$, hence the notation.)

There are standard bounds on Ξ , given by (see, e.g., [Trombi and Varadarajan 1972, 2.1])

$$\|g\|_\delta^{-1} \leq \Xi(g) \ll (\log\|g\| + 1)^{C_0} \|g\|_\delta^{-1} \tag{4-4}$$

for some $C_0 > 0$. Using these upper bounds, we find that for some $C_2 > 0$,

$$\int_G \chi_{T,\delta} \Xi(g) dg = \frac{1}{\mu(\{g \in G : \|g\|_\delta \leq T\})} \int_{g:\|g\|_\delta \leq T} \Xi(g) dg \ll (\log T + 1)^{C_2} T^{-1}.$$

Harish-Chandra’s function Ξ arises as follows; see, e.g., [Ghosh et al. 2013, Section 3]. Let (π, V) be the spherical representation of G unitarily induced from the trivial character of P . It holds that if $f \in L^1(K \backslash G / K)$ and $v \in V$ is K -invariant, then

$$\pi(f)v = \int_G f(g)\pi(g)v dg = \left(\int_G f(g)\Xi(g) dg \right)v.$$

Since $\pi(f_1 * f_2)v = \pi(f_1)\pi(f_2)v$,

$$\int_G (\chi_{T,\delta} * \chi_{T,\delta})(g)\Xi(g) dg = \left(\int_G \chi_{T,\delta}(g)\Xi(g) dg \right) \left(\int_G \chi_{T,\delta}(g)\Xi(g) dg \right) \ll (\log T + 1)^{2C_2} T^{-2}.$$

To show pointwise bounds, we notice that if $\chi_{T,\delta} * \chi_{T,\delta}(g) = R$, then $\chi_{T+1,\delta} * \chi_{T+1,\delta}(g') \gg R$, for g' in an annulus of size similar to that of g , i.e., for $C^{-1}\|g\|_\delta \leq \|g'\|_\delta \leq C\|g\|_\delta$ for some $C > 1$. This annulus is of measure $\asymp \|g\|_\delta^2$. Therefore,

$$\chi_{T,\delta} * \chi_{T,\delta}(g)\|g\|_\delta^2 \Xi(g) \ll \int_G (\chi_{T+1,\delta} * \chi_{T+1,\delta})(g')\Xi(g') dg' \ll (\log T + 1)^{2C_2} T^{-2},$$

and the first bound follows by applying the lower bound of (4-4).

The bound on χ_T follows from the bound on $\chi_{T,\delta}$ and the relation between them. □

Now consider the locally symmetric space $X_q = \Gamma_0(q) \backslash G / K$. As in the SL_2 case, it has finite measure, and we will consider the space $L^2(X_q)$, with the natural L^2 -norm.

We first discuss the spectral gap. We denote by $L_0^2(X_q)$ the functions in $L^2(X_q)$ of integral 0. Since χ_T is bi- K -invariant and sufficiently nice, the function χ_T acts by convolution from the right on $f \in L^2(X_q)$, and the resulting function is well defined pointwise if f is bounded. The operation sends $L_0(X_q)$ to itself.

Theorem 4.3 (spectral gap). *There exists $\tau > 0$ such that for $T > 0$ the operator χ_T satisfies for every $f \in L_0^2(X_q)$,*

$$\|f * \chi_T\|_2 \ll T^{-\tau} \|f\|_2.$$

The theorem follows from explicit versions of property (T), or explicit versions of the mean ergodic theorem (e.g., [Ghosh et al. 2013, Section 4]) which are actually true for all lattices in $G = SL_3(\mathbb{R})$ uniformly in T and the lattice. It is remarkable that the proof of Theorem 4.3 is much simpler than the proof of Theorem 2.5.

As in the SL_2 case, we define for $x_0 \in X_q$ the function $b_{T,x_0}(x) = \sum_{\gamma \in \Gamma_0(q)} \chi_T(\tilde{x}_0^{-1}\gamma x)$, where \tilde{x}_0 is any lift of x_0 to G .

We have a map $\iota : \Gamma_0(q)\backslash\Gamma \rightarrow X_q$ defined by $\iota(\Gamma_0(q)x_0) = \Gamma_0x_0K \in X_q$. By a slight abuse of notation we write $\iota(\Gamma_0(q)x_0) = \iota(x_0)$.

The map ι has fibers of bounded size (independently of q), and we may choose T_0 small enough so that $\iota(y) \neq \iota(y')$ implies that $b_{T_0,\iota(y)}$ and $b_{T_0,\iota(y')}$ have disjoint supports. In addition, $b_{T_0,\iota(y)}$ will have a bounded L^2 -norm as a function in $L^2(X_q)$.

Lemma 4.4. For $f \in L^2(X_q)$ bounded,

$$\langle f, b_{T,x_0} \rangle = (f * \chi_T^*)(x_0).$$

The proof is the same as the proof of [Lemma 2.3](#).

Lemma 4.5. Let $C > 0, \epsilon_0 > 0$ fixed. Let $x_0 \in \Gamma_0(q)\backslash\Gamma$ and assume for $T' \leq Cq^2$,

$$|\{\gamma \in \Gamma : \|\gamma\|_\delta \leq T', x_0\gamma = x_0\}| \ll_{\epsilon_0} q^{\epsilon_0} T'.$$

Then there exists $C' > 0$ depending only on C such that for $T = C'q^{1/3}$ it holds that for every $\epsilon > 0$,

$$\|b_{T,\iota(x_0)}\|_2 \ll_{\epsilon_0,\epsilon} q^{-1+\epsilon_0+\epsilon}.$$

Proof. Notice that $\gamma \in \Gamma$ satisfies $\Gamma_0(q)x_0\gamma = \Gamma_0(q)x_0$ if and only if $\gamma \in x_0^{-1}\Gamma_0(q)x_0$ (the last group is a well defined subgroup of Γ). Therefore we may rewrite the assumption in the following manner: For every $T' \leq Cq^2$,

$$|\{\gamma \in \Gamma_0(q) : \|x_0^{-1}\gamma x_0\|_\delta \leq T'\}| \ll_{\epsilon_0} q^{\epsilon_0} T', \tag{4-5}$$

where we identify x_0 with a fixed element of $\Gamma \leq G$.

Write using [Lemma 4.4](#),

$$\|b_{T,\iota(x_0)}\|_2^2 = \langle b_{T,\iota(x_0)}, b_{T,\iota(x_0)} \rangle = b_{T,\iota(x_0)} * \chi_T^*(\iota(x_0)) = \sum_{\gamma \in \Gamma_0(q)} (\chi_T * \chi_T^*)(x_0^{-1}\gamma x_0) \ll_{\epsilon} T^\epsilon \psi_{C_1 T^6}(x_0^{-1}\gamma x_0),$$

where in the last inequality we used [Lemma 4.2](#).

Therefore, the lemma will follow if we will prove that for $T = C'q^{1/3}$,

$$\begin{aligned} \sum_{\gamma \in \Gamma_0} \psi_{C_1 T^6}(x_0^{-1}\gamma x_0) &= T^{-6} \sum_{\gamma \in \Gamma_0(q): \|x_0^{-1}\gamma x_0\|_\delta \leq C_1 T^6} \|x_0^{-1}\gamma x_0\|_\delta^{-1} \\ &\ll q^{-2} \sum_{\gamma \in \Gamma_0(q): \|x_0^{-1}\gamma x_0\|_\delta \leq C_2 q^2} \|x_0^{-1}\gamma x_0\|_\delta^{-1} \\ &\stackrel{!}{\ll}_{\epsilon} q^{-2+\epsilon_0+\epsilon}, \end{aligned}$$

where $C_2 = C_1 C'^6$.

So it suffices to show that

$$\sum_{\gamma \in \Gamma_0(q): \|x_0^{-1}\gamma x_0\|_\delta^{-1} \leq C_2 q^2} \|x_0^{-1}\gamma x_0\|_\delta \stackrel{!}{\ll}_{\epsilon,\epsilon_0} q^{\epsilon+\epsilon_0}.$$

Applying (2-1) (discrete partial summation), with $g(\gamma) = \|\gamma\|_\delta$, $f(x) = x^{-1}$ and $Y = C_2q^2$, we have

$$\sum_{\substack{\gamma \in \Gamma_0(q) \\ \|x_0^{-1}\gamma x_0\|_\delta \leq C_2q^2}} \|x_0^{-1}\gamma x_0\|_\delta^{-1} \ll |\{\gamma : \|x_0^{-1}\gamma x_0\|_\delta \leq C_2q^2\}| q^{-2} + \int_1^{C_2q^2} |\{\gamma : \|x_0^{-1}\gamma x_0\|_\delta \leq S\}| S^{-2} dS.$$

Choosing C' small enough so that $C_2 = C_1C'^6 \leq C$ and applying (4-5) we obtain the desired bound for the last value:

$$\ll_{\epsilon, \epsilon_0} q^{\epsilon+\epsilon_0} + q^{\epsilon+\epsilon_0} \int_1^{C_3q^2} S^{-1} dS \ll_{\epsilon} q^{2\epsilon+\epsilon_0}. \quad \square$$

We denote by $\pi \in L^2(X_q)$ the constant probability function on X_q .

Using the counting result Theorem 1.4 we will now show that for many points $x_0 \in \Gamma_0(q)\backslash\Gamma$ the condition of Lemma 4.5 holds, and thus obtain:

Lemma 4.6. *There exists $C > 0$, $\tau > 0$, such that for every $\epsilon_0 > 0$, as $q \rightarrow \infty$ among primes, there exists a set $Y \subset \Gamma_0(q)\backslash\Gamma = P_q^{tr}$ of size $|Y| \geq (1 - o_{\epsilon_0}(1))|\Gamma_0(q)\backslash\Gamma|$, such that for every $\Gamma_0x_0 \in Y$, it holds for $T = Cq^{1/3}$ that*

$$\|b_{T, \iota(x_0)} * \chi_{T^\eta} - \pi\|_2 \ll_{\epsilon_0} q^{-1-\eta\tau+\epsilon_0}.$$

Proof. By Theorem 1.4 and (4-1) it holds that for some $C > 0$, for all $T \leq Cq^2$ and $\epsilon > 0$

$$\sum_{x_0 \in \Gamma_0(q)\backslash\Gamma} |\{\gamma \in \Gamma : \|\gamma\|_\delta \leq T, x_0\gamma = x_0\}| \ll_{\epsilon} q^{2+\epsilon}T.$$

Since $|\Gamma_0(q)\backslash\Gamma| = (1 + o(1))q^2$, we may choose a subset $Y \subset \Gamma_0(q)\backslash\Gamma$ of size

$$|Y| \geq (1 - o_{\epsilon_0}(1))|\Gamma_0(q)\backslash\Gamma|,$$

such that for every $x_0 \in Y$,

$$|\{\gamma \in \Gamma : \|\gamma\|_\delta \leq T, x_0\gamma = x_0\}| \ll_{\epsilon_0} q^{\epsilon_0}T.$$

We now apply Lemma 4.5 to every $x_0 \in Y$ to obtain

$$\|b_{T, \iota(x_0)}\|_2 \ll_{\epsilon_0} q^{-1+\epsilon_0}.$$

Next, we apply Theorem 4.3 as in Lemma 2.6 to deduce the final result. □

We may now finish the proof of Theorem 4.1, similar to the SL_2 case.

Lemma 4.7. *There is $C' > 0$ such that for $x_0, y \in \Gamma_0(q)\backslash\Gamma$, if $\langle b_{T, \iota(x_0)} * \chi_{T^\eta}, b_{T_0, \iota(y)} \rangle > 0$, then there is $\gamma \in \Gamma$ such that $x_0\gamma = y$, and $\|\gamma\|_K \leq C'T^{1+\eta}$.*

Proof. The proof is essentially the same as Lemma 2.7. We have by Lemma 4.4

$$b_{T, \iota(x_0)} * \chi_{T^\eta} * \chi_{T_0}^*(\iota(y_0)) > 0.$$

Denote by \tilde{x}_0, \tilde{y} as some lifts of x_0, y to Γ . We get $g_1, g_2, g_3 \in G, \gamma \in \Gamma_0(q)$ such that $\gamma^{-1}\tilde{x}_0g_1g_2g_3 = \tilde{y}$, with $g_1 \in \text{supp}(\chi_T), g_2 \in \text{supp}(\chi_{T^\eta}), g_3 \in \text{supp}(\chi_{T_0}^*)$. Writing $g = g_1g_2g_3$, we have that

$$\|g\|_K \ll \|g_1\|_K \|g_2\|_K \|g_3\|_K \ll T^{1+\eta}.$$

In addition $g = \tilde{x}_0^{-1}\gamma\tilde{y} \in x_0^{-1}\Gamma_0(q)y \subset \Gamma$, which says that $x_0\gamma = y$, as needed. □

To complete the proof, fix $\epsilon > 0$. Let $x_0 \in \Gamma_0(q) \setminus \Gamma$ be in the set Y of Lemma 4.6. Denote by \tilde{Z}_{x_0} the set of elements $y \in \Gamma_0(q) \setminus \Gamma$ for which there is no $\gamma \in \Gamma$ with $\|\gamma\|_K \leq q_K^{1/3+\epsilon}$ such that $x_0\gamma = y$. It is enough to prove that $\tilde{Z}_{x_0} = o(|\Gamma_0(q) \setminus \Gamma|) = o(q^2)$.

Choose $T = Cq^{1/3}$, and η small enough so that $C'T^{1+\eta} < q^{1/3+\epsilon}$, with C as in Lemma 4.6 and C' as in Lemma 4.7.

We denote $B = \sum_{y \in \tilde{Z}_{x_0}} b_{T,\iota(y)} \in L^2(X_q)$. Then by Lemma 4.7

$$\langle b_{T,x_0} * \chi_{T^\eta} - \pi, B \rangle = \frac{|\tilde{Z}_{x_0}|}{\text{Vol}(X_q)} \gg \frac{|\tilde{Z}_{x_0}|}{q^2}.$$

On the other hand, by the choice of x_0 and Lemma 4.6,

$$\langle b_{T,x_0} * \chi_{T^\eta} - \pi, B \rangle \ll \|B\|_2 \|b_{T,x_0} * \chi_{T^\eta} - \pi\|_2 \ll_{\epsilon_0} \sqrt{|\tilde{Z}_{x_0}|} q^{-1-\eta\tau+\epsilon_0}.$$

By combining the two estimates and choosing ϵ_0 small enough, we get the desired result

$$|\tilde{Z}_{x_0}| \ll_{\epsilon_0} q^{2-2\eta\tau-2\epsilon_0} = o(q^2).$$

5. Optimal lifting for the action on flags

In this section we prove optimal lifting for another action of $SL_3(\mathbb{Z})$. Let B_q be the set of complete flags in \mathbb{F}_q^3 , i.e.,

$$B_q = \{(V_1, V_2) : 0 < V_1 < V_2 < \mathbb{F}_q^3\},$$

i.e., $V_1 \subset V_2$ are subspaces of \mathbb{F}_q^3 , such that $\dim V_1 = 1, \dim V_2 = 2$.

There is a natural action $\Phi_q : SL_3(\mathbb{Z}) \rightarrow \text{Sym}(B_q)$. It gives rise to a nonprincipal congruence subgroup

$$\Gamma'_2(q) = \left\{ \begin{pmatrix} * & a & b \\ * & * & c \\ * & * & * \end{pmatrix} \in SL_3(\mathbb{Z}) : a = b = c = 0 \pmod q \right\}.$$

Concretely,

$$\Gamma'_2(q) = \{\gamma \in SL_3(\mathbb{Z}) : \Phi_q(\gamma)(\mathbf{1}) = \mathbf{1}\},$$

where

$$\mathbf{1} = \left(\text{span} \left\{ \begin{pmatrix} 0 \\ 0 \\ 1 \end{pmatrix} \right\}, \text{span} \left\{ \begin{pmatrix} 0 \\ 0 \\ 1 \end{pmatrix}, \begin{pmatrix} 0 \\ 1 \\ 0 \end{pmatrix} \right\} \right)$$

The result reads as follows:

Theorem 5.1. *Let $\Gamma = \text{SL}_3(\mathbb{Z})$, and for a prime q let B_q and $\Phi_q : \text{SL}_3(\mathbb{Z}) \rightarrow \text{Sym}(B_q)$ as above. Then for every $\epsilon > 0$, as $q \rightarrow \infty$, there exists a set $Y \subset B_q$ of size $|Y| \geq (1 - o_\epsilon(1))|B_q|$, such that for every $x \in Y$, there exists a set $Z_x \subset B_q$ of size $|Z_x| \geq (1 - o_\epsilon(1))|B_q|$, such that for every $y \in Z_x$, there exists an element $\gamma \in \Gamma$ satisfying $\|\gamma\|_\infty \leq q^{1/2+\epsilon}$, such that $\Phi_q(\gamma)x = y$.*

The exponent $\frac{1}{2}$ is optimal, since the size of B_q is $|B_q| \asymp q^3$, while the number of elements $\gamma \in \text{SL}_3(\mathbb{Z})$ satisfying $\|\gamma\|_\infty \leq T$ is $\asymp T^6$. This also hints why handling flags is harder than handling the projective plane: The volume of the homogenous space is larger (q^3 instead of q^2). In comparison, the principal congruence subgroup gives the much larger volume q^8 , and optimal lifting for it is still open.

The proof of **Theorem 5.1** is very similar to the proof of **Theorem 1.3**. The analytic part is essentially identical to **Section 4**, with some minor modifications coming from the fact that the size $|P_q| \asymp q^2$ is replaced by $|B_q| \asymp q^3$. We therefore leave it to the reader.

The counting part needs a slightly more delicate argument. The needed result is an analog of **Theorem 1.4**, as follows:

Theorem 5.2. *There exists a constant $C > 0$ such that for every prime q , $T \leq Cq^3$ and $\epsilon > 0$ it holds that*

$$|\{(\gamma, x) \in \text{SL}_3(\mathbb{Z}) \times B_q : \|\gamma\|_\infty \|\gamma^{-1}\|_\infty \leq T, \Phi_q(\gamma)(x) = x\}| \ll_\epsilon q^{3+\epsilon} T.$$

We prove **Theorem 5.2** in the rest of this section.

By dyadically dividing the range of $\|\gamma\|_\infty$ into $O(\log T)$ subintervals, it is enough to prove that there exists $C > 0$ such that for every $S \leq R$ and $RS \leq Cq^3$:

$$|\{(\gamma, x) \in \text{SL}_3(\mathbb{Z}) \times B_q : \|\gamma\|_\infty \leq S, \|\gamma^{-1}\|_\infty \leq R, \Phi_q(\gamma)(x) = x\}| \ll_\epsilon q^{3+\epsilon} RS.$$

We identify $\Phi_q(\gamma) \in \text{SL}_3(\mathbb{F}_q)$, and let $P(t) \in \mathbb{F}_q[t]$ be the characteristic polynomial of $\Phi_q(\gamma)$.

We first notice that if $x = (V_1, V_2) \in B_q$ is a fixed point of $\Phi_q(\gamma)$, then V_1 defines a projective eigenvector of $\Phi_q(\gamma)$, so $\Phi_q(\gamma)$ has an eigenvector and $P(t)$ has a root. Similarly, V_2 is a two-dimensional invariant subspace containing an eigenvector, so $P(t)$ has at least two roots. We deduce that if $\Phi_q(\gamma)$ has a fixed point $x \in B_q$, then the polynomial $P(t)$ splits. Assuming $P(t)$ splits, we divide into several subcases:

(1) Assume that $P(t)$ has three different roots, $\Phi_q(\gamma)$ is diagonalizable, with eigenvectors v_1, v_2, v_3 . Then $\Phi_q(\gamma)$ fixes the points of the form (V_1, V_2) , $V_1 = \text{span}\{v_i\}$, $V_2 = \text{span}\{v_i, v_j\}$, for $1 \leq i \neq j \leq 3$. So $\Phi_q(\gamma)$ has 6 fixed points in B_q .

(2) Assume that $P(t)$ has the roots $(\alpha, \alpha, \alpha^{-2})$, $\alpha^3 \neq 1$, and the eigenspace $\ker(\Phi_q(\gamma) - \alpha I)$ of eigenvalue α is of dimension 1. Then let v_1 be an eigenvector of eigenvalue α , v_2 an eigenvector of eigenvalue α^{-2} , and $U = \ker(\Phi_q(\gamma) - \alpha I)^2$ the two-dimensional generalized eigenspace of eigenvalue α . Then the fixed points of $\Phi_q(\gamma)$ are of the form $V_1 = \text{span}\{v_i\}$, $V_2 = \text{span}\{v_1, v_2\}$ for $1 \leq i \neq j \leq 2$, or of the form $V_1 = \text{span}\{v_1\}$, $V_2 = U$. So $\Phi_q(\gamma)$ has 3 fixed points in B_q .

(3) Assume that $P(t)$ has a triple root $\alpha \in \mathbb{F}_q$ (with $\alpha^3 = 1$), and the eigenspace $\ker(\Phi_q(\gamma) - \alpha I)$ is one dimensional, then the only fixed point is of the form $V_1 = \ker(\Phi_q(\gamma) - \alpha I)$, $V_2 = \ker(\Phi_q(\gamma) - \alpha I)^2$. So $\Phi_q(\gamma)$ has a unique fixed point in B_q .

(4) Assume that $P(t)$ has roots $(\alpha, \alpha, \alpha^{-2})$, $\alpha^3 \neq 1$, and the eigenspace $U = \ker(\Phi_q(\gamma) - \alpha I)$ of eigenvalue α is of dimension 2, i.e., the Jordan form of $\Phi_q(\gamma)$ is

$$\begin{pmatrix} \alpha & 0 & 0 \\ 0 & \alpha & 0 \\ 0 & 0 & \alpha^{-2} \end{pmatrix}, \quad \alpha^3 \neq 1.$$

Let $v_1 \in U$ denote an eigenvector of eigenvalue α , and let v_2 be an eigenvector of eigenvalue α^{-2} . Then all fixed points of $\Phi_q(\gamma)$ are of the form $V_1 = \text{span}\{v_i\}$, $v_2 = \text{span}\{v_i, v_j\}$, $1 \leq i \neq j \leq 2$, or $V_1 = \text{span}\{v_1\}$, $V_2 = U$ (for different choices of v_1). There are $(q + 1)$ options for $\text{span}\{v_1\}$, so in total $\Phi_q(\gamma)$ has $3(q + 1)$ fixed points in B_q .

(5) If $P(t)$ has a unique root $\alpha \in \mathbb{F}_q$, $\alpha^3 = 1$, and the eigenspace $U = \ker(\Phi_q(\gamma) - \alpha I)$ of eigenvalue α is of dimension 2, then the Jordan form of $\Phi_q(\gamma)$ is of the form

$$\begin{pmatrix} \alpha & 1 & 0 \\ 0 & \alpha & 0 \\ 0 & 0 & \alpha \end{pmatrix} \quad \alpha^3 = 1.$$

In this case, the operator $\Phi_q(\gamma) - \alpha$ is nilpotent, with $\dim \text{Im}(\Phi_q(\gamma) - \alpha) = 1$, $\dim \ker(\Phi_q(\gamma) - \alpha) = 2$. If $x = (V_1, V_2)$ is a fixed point of $\Phi_q(\gamma)$, then $U = V_2 \cap \ker(\Phi_q(\gamma) - \alpha)$ satisfies either $\dim U = 2$ or $\dim U = 1$:

- If $\dim U = 1$, we must choose $V_1 = U$, and $V_2 = (\Phi_q(\gamma) - \alpha)V_2$, and by dimension counting $V_1 = \text{Im}(\Phi_q(\gamma) - \alpha)$. Therefore, V_1 is uniquely defined and V_2 can be chosen as any subspace containing V_1 , in $q + 1$ ways.
- If $\dim U = 2$, then $V_2 = \ker(\Phi_q(\gamma) - \alpha I)$ is uniquely defined, and V_1 can be chosen in $q + 1$ ways as a subspace of V_2 .

We conclude that $\Phi_q(\gamma)$ has $2(q + 1)$ fixed points in B_q .

(6) If $P(t)$ has a unique root $\alpha \in \mathbb{F}_q$, $\alpha^3 = 1$ and $\Phi_q(\gamma) = \alpha I_{SL_3(\mathbb{F}_q)}$, then every $x \in B_q$ is a fixed point of $\Phi_q(\gamma)$.

As in Section 3, we call $\gamma \in SL_3(\mathbb{Z})$ bad mod q if $\Phi_q(\gamma)$ has an eigenspace of dimension at least 2, i.e., corresponds to one of the last three cases above.

Theorem 5.2 will therefore follow from the following two lemmas:

Lemma 5.3. *There exists $C > 0$ such that for every $\alpha \in \mathbb{F}_q$, $\alpha^3 = 1$, $S \leq R$ and $RS \leq Cq^3$*

$$|\{\gamma \in SL_3(\mathbb{Z}) : \|\gamma\|_\infty \leq S, \|\gamma^{-1}\|_\infty \leq R, \gamma = \alpha I \pmod q\}| \ll_\epsilon q^\epsilon RS.$$

Lemma 5.4. *There exists $C > 0$ such that for every $S \leq R$ and $RS \leq Cq^3$*

$$|\{\gamma \in \text{SL}_3(\mathbb{Z}) : \|\gamma\|_\infty \leq S, \|\gamma^{-1}\|_\infty \leq R, \gamma \text{ bad mod } q\}| \ll_\epsilon q^{2+\epsilon} RS.$$

Proof of Lemma 5.3. We will give a short and nonefficient estimate, which may be improved significantly, at least when $\alpha = 1 \in \mathbb{F}_q$.

Fix some lift of α to \mathbb{Z} , such that $\alpha^3 = 1 \pmod{q^2}$. Then $(\gamma - \alpha I)^2 = 0 \pmod{q^2}$, so $\gamma^2 - 2\alpha\gamma + \alpha^2 I = 0 \pmod{q^2}$. Multiply by $\alpha\gamma^{-1}$ and we get that

$$\gamma^{-1} = 2\alpha^2 - \alpha\gamma \pmod{q^2}. \tag{5-1}$$

By the inversion formula, it holds that $\|\gamma^{-1}\|_\infty \leq 2\|\gamma\|_\infty^2$. We may therefore assume that $R \leq 2S^2$, so $R^3 \leq 2R^2S^2 \leq 2C^2q^6$. By adjusting the constant C we may assume that $\|\gamma^{-1}\|_\infty \leq R \leq q^2/4$, and (5-1) then implies that given an entry of γ , we know the corresponding entry of γ^{-1} .

As in Section 3, we denote the entries of γ by a_{ij} and the entries of γ^{-1} by b_{ij} .

Since $\gamma = \alpha I \pmod{q}$, we may choose the diagonal of γ using $\ll (S/q + 1)^3$ options. By (5-1) we know the diagonal of γ^{-1} . We can write $a_{12}a_{21} = a_{11}a_{22} - b_{33}$, and the right hand side is known. If $a_{11}a_{22} - b_{33} \neq 0$ then there are $\ll S^\epsilon$ options for a_{12}, a_{21} . If $a_{11}a_{22} - b_{33} = 0$ then there are $\ll (S/q + 1)$ options for a_{12}, a_{21} . The same is true for the other nondiagonal elements.

All in all, there are

$$\ll_\epsilon (S/q + 1)^3 (S/q + 1 + S^\epsilon)^3$$

options for γ . If $S \leq q$ this is obviously smaller than $q^\epsilon RS$. If $S \geq q$, then we need to show that

$$(S/q)^6 \ll q^\epsilon RS$$

or $S^5/R \ll q^{6+\epsilon}$, which is true since

$$S^5/R \leq S^4 \leq (RS)^2 \leq q^6.$$

□

For the proof of Lemma 5.4 we will need the following:

Lemma 5.5. *The number of solutions for (3-2), (3-3) in $\text{tr } \gamma, \text{tr } \gamma^{-1} \in \mathbb{Z}, \alpha \in \mathbb{F}_q, |\text{tr } \gamma| \leq S, |\text{tr } \gamma^{-1}| \leq R$ is bounded by $\ll (S/q + 1)(R/q + 1) + q$.*

Proof. Assume that $(x_1, y_1, \alpha), (x_2, y_2, \alpha)$ are solutions. Then by (3-2), $x_1 - x_2 = y_1 - y_2 = 0 \pmod{q}$. Denote $z = (x_1 - y_1)/q, w = (x_2 - y_2)/q$. Notice that $|z| \leq 2S/q, |w| \leq 2R/q$. By (3-3) (z, w, α) is a solution to $\alpha qz - qw = 0 \pmod{q^2}$, or

$$\alpha z - w = 0 \pmod{q}. \tag{5-2}$$

Therefore, A solutions with the same $\alpha \in \mathbb{F}_q$ for (3-2),(3-3) give A solutions to (5-2) with the same $\alpha \in \mathbb{F}_q$. So the total number of solutions is bounded by the number of solutions of (5-2) with $|z| \leq 2S/q, |w| \leq 2R/q$,

$\alpha \in \mathbb{F}_q$. The last number is bounded by $\ll (S/q + 1)(R/q + 1) + q$, since every choice of z, w sets α uniquely, unless $z = w = 0$. \square

Proof of Lemma 5.4. Since our definition of a bad element mod q agrees with the definition in Section 4, by Lemma 5.5 there are $\ll (S/q + 1)(R/q + 1) + q$ options for $\text{tr } \gamma, \text{tr } \gamma^{-1}, \alpha$. In our range of parameters it holds that $RS \leq Cq^3$ and since $\|\gamma^{-1}\|_\infty \leq 2\|\gamma\|_\infty^2$, we may assume that $R \leq 2S^2$, so $R \ll q^2$, and therefore $(S/q + 1)(R/q + 1) + q \ll q$.

There are at most S^2 options for a_{11}, a_{22} , and knowing $\text{tr } \gamma$, we have now all of the diagonal of γ . By (3-1), the diagonal of γ determines the diagonal of $\gamma^{-1} \pmod q$. Lifting, the first two entries b_{11}, b_{22} have just $(R/q + 1)^2$ options, giving b_{33} for free. Thus there are at most $\ll qS^2(R/q + 1)^2$ options.

In the nonexceptional case when the nondiagonal entries are nonzero, the rest of the matrix has $\ll_\epsilon q^\epsilon$ options. So we should show that

$$qS^2(R/q + 1)^2 \ll RSq^2,$$

or $S(R/q + 1)^2 \ll Rq$. For $R < q$, this reduces to $S \ll Rq$, which is obvious. For $R > q$, this reduces to $RS \ll q^3$, which is again true.

Let us deal with the exceptional case. Without loss of generality we may assume that $a_{11}a_{22} = b_{33}$ and $a_{21} = 0$. We further separate into cases:

(1) If all other nondiagonal entries besides a_{21} and a_{12} are nonzero, then we may guess the diagonal of γ and γ^{-1} as before, and get the other nondiagonal entries using divisor bounds. The matrix γ is then of the form

$$\begin{pmatrix} * & ? & \times \\ 0 & * & \times \\ \times & \times & * \end{pmatrix},$$

with a_{12} the only unknown and where \times denotes a nonzero value. Then we get that $\det \gamma = Ea_{12} + F$, with $E = a_{23}a_{31} \neq 0, F$ known, so a_{12} is determined uniquely from $\det \gamma = 1$.

(2) If $a_{31} = 0$, then $a_{11} = \alpha = \pm 1$, and the matrix is of the form

$$\begin{pmatrix} \pm 1 & * & * \\ 0 & * & * \\ 0 & * & * \end{pmatrix}.$$

As in the first exceptional case of Section 3, denote $A = \begin{pmatrix} a_{22} & a_{23} \\ a_{32} & a_{33} \end{pmatrix}$. We know that $\det A = \alpha = \pm 1$, and either $\text{tr } A = 0 \pmod q$ or $\text{tr } A = 2 \pmod q$. Therefore, a_{22}, a_{33} have at most $\ll S(S/q + 1)$ options. If $a_{22}a_{33} \neq \det A = \pm 1$ then we get q^ϵ options for a_{23}, a_{32} by the divisor bound. If $a_{22}a_{33} = \det A = \pm 1$, then they are both ± 1 , and $a_{23}a_{32} = 0$, so there are $\ll S$ options for A . So in any case A has at most $q^\epsilon S(S/q + 1)$ options. The remaining two entries have at most S^2 options, so all in all there are $S^3(S/q + 1)$ options. It remains to prove that

$$S^3(S/q + 1) \ll RSq^2,$$

which is a simple verification.

(3) If $a_{23} = 0$ then $a_{22} = \alpha = \pm 1$, and the matrix is of the form

$$\begin{pmatrix} * & * & * \\ 0 & \pm 1 & 0 \\ * & * & * \end{pmatrix}.$$

We reduce to the previous case (after permuting indices and transposing).

(4) We may now assume $a_{31} \neq 0$, $a_{23} \neq 0$. If $a_{13} = 0$, we may assume $a_{12} \neq 0$, otherwise we reduce to a previous case. We now guess the diagonals as before, and further diverge into subcases:

(a) If $a_{32} \neq 0$: Then since $a_{23} \neq 0$ we have $a_{23}a_{32} = a_{22}a_{33} - b_{11}$, so we have $\ll_{\epsilon} q^{\epsilon}$ options for a_{23} , a_{32} by the divisor bound. Then the matrix is of the form

$$\begin{pmatrix} * & ? & 0 \\ 0 & * & \times \\ ? & \times & * \end{pmatrix}.$$

From $\det \gamma = 1$ we get $a_{12}a_{31}$, which is nonzero. By the divisor bound we are done.

(b) If $a_{32} = 0$, the matrix is of the form

$$\begin{pmatrix} * & ? & 0 \\ 0 & * & ? \\ ? & 0 & * \end{pmatrix}.$$

From $\det \gamma = 1$ we get $a_{12}a_{23}a_{31}$, which is again nonzero, and by the divisor bound we are done.

(5) If $a_{13} \neq 0$, $a_{23} \neq 0$, $a_{31} \neq 0$, $a_{32} = 0$. We may assume that $a_{12} \neq 0$ otherwise we reduce to a previous case. Then we guess the diagonals as usual, and since $a_{31}a_{13} \neq 0$ we know them in $\ll_{\epsilon} q^{\epsilon}$ ways by the divisor bound. Then the matrix is of the form

$$\begin{pmatrix} * & ? & \times \\ 0 & * & ? \\ \times & 0 & \alpha^{-2} \end{pmatrix}.$$

From $\det \gamma = 1$ we get $a_{12}a_{23}$ which is nonzero, and by the divisor bound we are done. \square

Acknowledgments

We are grateful to Amos Nevo and Elon Lindenstrauss for various discussions surrounding this project, and for Peter Sarnak for his continued encouragement. We also thank Amos Nevo and the anonymous referee for careful reading of previous versions of this article and for pointing out some inaccuracies.

This work is part of the Ph.D. theses of the authors at the Hebrew University of Jerusalem. The first author was under the guidance of Prof. Alex Lubotzky, and was supported by the ERC grant 692854. The second author is under the guidance of Prof. Tamar Ziegler, and is supported by the ERC grant 682150.

Added in proof

In a recent preprint Jana and Kamber [2022, Theorem 6], following a breakthrough of Assing and Blomer [2022], proved [Conjecture 1.2](#) for q square-free.

References

- [Assing and Blomer 2022] E. Assing and V. Blomer, “The density conjecture for principal congruence subgroups”, preprint, 2022. [arXiv 2204.08868](#)
- [Blomer 2019] V. Blomer, “Density theorems for $GL(n)$ ”, preprint, 2019. [arXiv 1906.07459](#)
- [Blomer et al. 2017] V. Blomer, J. Buttcane, and P. Maga, “Applications of the Kuznetsov formula on $GL(3)$ II: the level aspect”, *Math. Ann.* **369**:1–2 (2017), 723–759. [MR](#)
- [Burger et al. 1992] M. Burger, J.-S. Li, and P. Sarnak, “Ramanujan duals and automorphic spectrum”, *Bull. Amer. Math. Soc. (N.S.)* **26**:2 (1992), 253–257. [MR](#) [Zbl](#)
- [Duke et al. 1993] W. Duke, Z. Rudnick, and P. Sarnak, “Density of integer points on affine homogeneous varieties”, *Duke Math. J.* **71**:1 (1993), 143–179. [MR](#) [Zbl](#)
- [Gamburd 2002] A. Gamburd, “On the spectral gap for infinite index “congruence” subgroups of $SL_2(\mathbb{Z})$ ”, *Israel J. Math.* **127** (2002), 157–200. [MR](#) [Zbl](#)
- [Ghosh et al. 2013] A. Ghosh, A. Gorodnik, and A. Nevo, “Diophantine approximation and automorphic spectrum”, *Int. Math. Res. Not.* **2013**:21 (2013), 5002–5058. [MR](#) [Zbl](#)
- [Ghosh et al. 2018] A. Ghosh, A. Gorodnik, and A. Nevo, “Best possible rates of distribution of dense lattice orbits in homogeneous spaces”, *J. Reine Angew. Math.* **745** (2018), 155–188. [MR](#) [Zbl](#)
- [Golubev and Kamber 2019] K. Golubev and A. Kamber, “Cutoff on hyperbolic surfaces”, *Geom. Dedicata* **203** (2019), 225–255. [MR](#) [Zbl](#)
- [Golubev and Kamber 2020] K. Golubev and A. Kamber, “On Sarnak’s density conjecture and its applications”, preprint, 2020. [arXiv 2004.00373](#)
- [Gorodnik and Weiss 2007] A. Gorodnik and B. Weiss, “Distribution of lattice orbits on homogeneous varieties”, *Geom. Funct. Anal.* **17**:1 (2007), 58–115. [MR](#) [Zbl](#)
- [Hardy and Wright 1979] G. H. Hardy and E. M. Wright, *An introduction to the theory of numbers*, 5th ed., Oxford University Press, New York, 1979. [MR](#) [Zbl](#)
- [Huntley and Katznelson 1993] J. Huntley and Y. R. Katznelson, “Density theorems for congruence groups in real rank 1”, *Duke Math. J.* **71**:2 (1993), 463–473. [MR](#) [Zbl](#)
- [Huxley 1986] M. N. Huxley, “Exceptional eigenvalues and congruence subgroups”, pp. 341–349 in *The Selberg trace formula and related topics* (Brunswick, Maine, 1984), edited by D. A. Hejhal et al., Contemp. Math. **53**, Amer. Math. Soc., Providence, RI, 1986. [MR](#) [Zbl](#)
- [Jana and Kamber 2022] S. Jana and A. Kamber, “On the local L^2 -bound of the Eisenstein series”, preprint, 2022. [arXiv 2210.16291](#)
- [Knapp 1986] A. W. Knap, *Representation theory of semisimple groups*, Princeton Mathematical Series **36**, Princeton University Press, 1986. [MR](#) [Zbl](#)
- [Maucourant 2007] F. Maucourant, “Homogeneous asymptotic limits of Haar measures of semisimple linear groups and their lattices”, *Duke Math. J.* **136**:2 (2007), 357–399. [MR](#) [Zbl](#)
- [Oh 2002] H. Oh, “Uniform pointwise bounds for matrix coefficients of unitary representations and applications to Kazhdan constants”, *Duke Math. J.* **113**:1 (2002), 133–192. [MR](#) [Zbl](#)
- [Sarnak 2005] P. Sarnak, “Notes on the generalized Ramanujan conjectures”, pp. 659–685 in *Harmonic analysis, the trace formula, and Shimura varieties*, edited by J. Arthur et al., Clay Math. Proc. **4**, Amer. Math. Soc., Providence, RI, 2005. [MR](#) [Zbl](#)
- [Sarnak 2015] P. Sarnak, letter to Stephen D. Miller and Naser Talebizadeh Sardari on optimal strong approximation by integral points on quadrics, 2015.

[Sarnak and Xue 1991] P. Sarnak and X. X. Xue, “Bounds for multiplicities of automorphic representations”, *Duke Math. J.* **64**:1 (1991), 207–227. [MR](#) [Zbl](#)

[Trombi and Varadarajan 1972] P. C. Trombi and V. S. Varadarajan, “Asymptotic behaviour of eigen functions on a semisimple Lie group: the discrete spectrum”, *Acta Math.* **129**:3-4 (1972), 237–280. [MR](#) [Zbl](#)

Communicated by Roger Heath-Brown

Received 2021-08-09 Revised 2022-03-14 Accepted 2022-05-10

ak2356@dpmms.cam.ac.uk

*Centre for Mathematical Sciences, University of Cambridge, Cambridge,
United Kingdom*

hagai.lavner@mail.huji.ac.il

*Einstein Institute of Mathematics, The Hebrew University of Jerusalem,
Jerusalem, Israel*

Sums of two squares are strongly biased towards quadratic residues

Ofir Gorodetsky

Chebyshev famously observed empirically that more often than not, there are more primes of the form $3 \pmod{4}$ up to x than of the form $1 \pmod{4}$. This was confirmed theoretically much later by Rubinstein and Sarnak in a logarithmic density sense. Our understanding of this is conditional on the generalized Riemann hypothesis as well as on the linear independence of the zeros of L -functions.

We investigate similar questions for sums of two squares in arithmetic progressions. We find a significantly stronger bias than in primes, which happens for almost all integers in a *natural density* sense. Because the bias is more pronounced, we do not need to assume linear independence of zeros, only a Chowla-type conjecture on nonvanishing of L -functions at $\frac{1}{2}$. To illustrate, we have under GRH that the number of sums of two squares up to x that are $1 \pmod{3}$ is greater than those that are $2 \pmod{3}$ 100% of the time in natural density sense.

1. Introduction

1A. Review of sums of two squares in arithmetic progressions. Let S be the set of positive integers expressible as a sum of two perfect squares. We denote by $\mathbf{1}_S$ the indicator function of S . It is multiplicative and for a prime p we have

$$\mathbf{1}_S(p^k) = 0 \quad \text{if and only if} \quad p \equiv 3 \pmod{4} \text{ and } 2 \nmid k. \quad (1-1)$$

Landau [1908] proved that

$$\#(S \cap [1, x]) \sim \frac{Kx}{\sqrt{\log x}}$$

where $K = \prod_{p \equiv 3 \pmod{4}} (1 - p^{-2})^{-1/2} / \sqrt{2} \approx 0.764$ is the Landau–Ramanujan constant; see [Hardy 1940, Lecture IV] for Hardy’s account of Ramanujan’s unpublished work on this problem. Landau’s method yields an asymptotic expansion in descending powers of $\log x$, which gives an error term $O_k(x/(\log x)^{k+1/2})$ for each $k \geq 1$.¹ Prachar [1953] proved that sums of two squares are equidistributed

MSC2020: primary 11N37; secondary 11M06.

Keywords: Chebyshev’s bias, sums of two squares, omega function, prime divisor function.

¹A more complicated main term, leading to a significantly better error term (conjecturally $O_\varepsilon(x^{1/2+\varepsilon})$, but no better than that), is described e.g., in [Gorodetsky and Rodgers 2021, Appendix B]; compare [Ramachandra 1976; Montgomery and Vaughan 2007, page 187; David et al. 2022, Theorem 2.1].

in arithmetic progressions, in the following sense. If $(a, q) = 1$ then

$$S(x; q, a) := \#\{n \in S : n \leq x, n \equiv a \pmod{q}\} \sim \frac{(4, q)}{(2, q)q} \prod_{\substack{p|q \\ p \equiv 3 \pmod{4}}} \left(1 + \frac{1}{p}\right) \frac{Kx}{\sqrt{\log x}}$$

as $x \rightarrow \infty$ as long as $a \equiv 1 \pmod{(4, q)}$; see Iwaniec’s work [1976] on the half-dimensional sieve for results allowing q to vary with x . The condition $a \equiv 1 \pmod{(4, q)}$ is necessary: otherwise $(a, q) = 1$ and $a \not\equiv 1 \pmod{(4, q)}$ imply $a \equiv 3 \pmod{4}$. However, S is disjoint from $3 \pmod{4}$.

1B. Main theorem and corollary. Here we consider a Chebyshev’s bias phenomenon for S . We ask, what can be said about the size of the set

$$\{n \leq x : S(n; q, a) > S(n; q, b)\} \tag{1-2}$$

for distinct $a, b \pmod{q}$ with $a \equiv b \equiv 1 \pmod{(4, q)}$ and $(a, q) = (b, q) = 1$? These conditions guarantee that $S(n; q, a) \sim S(n; q, b) \rightarrow \infty$ as $n \rightarrow \infty$, so it is sensible to study (1-2). We let χ_{-4} be the unique nonprincipal Dirichlet character modulo 4. Motivated by numerical evidence (based on $n \leq 10^8$) showing $S(n; 3, 1) - S(n; 3, 2)$ and $S(n; 5, 1) - S(n; 5, 3)$ are positive much more frequently than not, we were led to discover and prove the following.

Theorem 1.1. Fix a positive integer q . Assume that the generalized Riemann hypothesis (GRH) holds for the Dirichlet L -functions $L(s, \chi)$ and $L(s, \chi\chi_{-4})$ for all Dirichlet character χ modulo q . Then, whenever a, b satisfy $a \equiv b \equiv 1 \pmod{(4, q)}$, $(a, q) = (b, q) = 1$ and

$$C_{q,a,b} := \sum_{\substack{\chi \pmod{q} \\ \chi^2 = \chi_0}} (\chi(a) - \chi(b)) \left(1 - \frac{\chi(2)}{\sqrt{2}}\right)^{-1/2} \sqrt{L\left(\frac{1}{2}, \chi\right)L\left(\frac{1}{2}, \chi\chi_{-4}\right)} > 0 \tag{1-3}$$

we have, as $x \rightarrow \infty$,

$$\#\{n \leq x : S(n; q, a) > S(n; q, b)\} = x(1 + o(1)).$$

Here (and later) χ_0 is the principal character modulo q . Observe that $\chi(a) = \chi(b) = 1$ for $\chi = \chi_0$ as well as for $\chi = \chi_0\chi_{-4}$ (if $4 \mid q$), so these two characters may be omitted from the sum (1-3). As we explain in Remark 1.2 below, $L(\frac{1}{2}, \chi)L(\frac{1}{2}, \chi\chi_{-4})$ is nonnegative under the conditions of Theorem 1.1; the square root we take in (1-3) is the nonnegative one.

Remark 1.2. Under GRH for (nonprincipal) real χ , we have $L(\frac{1}{2}, \chi) \geq 0$ since otherwise there is a zero of $L(s, \chi)$ in $(\frac{1}{2}, 1)$ by the intermediate value theorem. Similarly, $L(\frac{1}{2}, \chi\chi_{-4}) \geq 0$ if $\chi \neq \chi_0\chi_{-4}$. Conrey and Soundararajan [2002], proved, unconditionally, that for a positive proportion of quadratic characters χ we have $L(s, \chi) > 0$ on $(\frac{1}{2}, 1)$ implying $L(\frac{1}{2}, \chi) \geq 0$. Chowla’s conjecture [1965] states that $L(\frac{1}{2}, \chi) \neq 0$ for all real Dirichlet characters. It was studied extensively; see e.g., Soundararajan [2000].

If $\chi(a) = 1$ for all real characters modulo q then a is a quadratic residue modulo q , and vice versa. Let us specialize a to be a quadratic residue modulo q and b to be a nonquadratic residue. We observe that

(on GRH) $(\chi(a) - \chi(b))\sqrt{L(\frac{1}{2}, \chi)L(\frac{1}{2}, \chi\chi_{-4})}$ is nonnegative for each real $\chi \pmod q$ that is not χ_0 or $\chi_0\chi_{-4}$. Hence, under GRH and our assumptions on a and b , a necessary and sufficient condition for (1-3) to hold is that $L(\frac{1}{2}, \chi)L(\frac{1}{2}, \chi\chi_{-4}) \neq 0$ for some real $\chi \pmod q$ with $\chi(b) = -1$. One way to guarantee this is to assume Chowla's conjecture. We state this as the following corollary.

Corollary 1.3. *Suppose that GRH holds for χ and $\chi\chi_{-4}$ as χ varies over all Dirichlet characters modulo q . Let a and b be quadratic and nonquadratic residues modulo q , respectively, with $(a, q) = (b, q) = 1$ and $a \equiv b \equiv 1 \pmod{4, q}$. If $L(\frac{1}{2}, \chi)L(\frac{1}{2}, \chi\chi_{-4}) \neq 0$ for some $\chi \pmod q$ with $\chi(b) = -1$ then*

$$S(n; q, a) > S(n; q, b) \tag{1-4}$$

holds for a density-1 set of integers. In particular, if Chowla's conjecture holds then (1-4) holds for a density-1 set of integers.

It would be interesting to try and establish the positivity of (1-3), possibly in a statistical sense, without hypotheses like Chowla's conjecture.

For a given Dirichlet character χ , one can computationally verify that $L(\frac{1}{2}, \chi)$ is nonzero, and in fact compute all zeros of $L(s, \chi)$ up to a certain height; see Rumely [1993] which in particular shows $L(\frac{1}{2}, \chi) \neq 0$ for characters of conductor ≤ 72 . Nowadays computing $L(\frac{1}{2}, \chi)$ is a one-line command in *Mathematica*, and so the verification of (1-3) is practical for fixed q, a and b .

We expect the expression in (1-3) to be nonzero as long as $\chi(a) \neq \chi(b)$ for some real character, or equivalently, if a/b is nonquadratic residue modulo q . It is instructive to consider the following two possibilities for a and b separately:

- Suppose a, b and a/b are all nonquadratic residues, a situation that could occur only if the modulus q is composite. Although the expression $C_{q,a,b}$ should be nonzero and give rise to a bias, it seems the sign is very difficult to predict. Interestingly, for primes, as we shall review below, there is no bias in this case.
- If exactly one of a and b is a quadratic residue then Corollary 1.3 tells us the direction of the bias (if it exists) is towards the quadratic residue. A sufficient condition for the bias to exist is Chowla's conjecture.

1C. Comparison with primes. Chebyshev's bias was originally studied in the case of primes, that is, replacing S by the set of primes. Letting $\pi(x; q, a)$ be the numbers of primes up to x lying in the arithmetic progression $a \pmod q$, Chebyshev [1853, pages 697–698] famously observed that $\pi(x; 4, 3) > \pi(x; 4, 1)$ happens more often than not.

Littlewood [1914] showed that $\pi(x; 4, 3) - \pi(x; 4, 1)$ changes sign infinitely often. Knapowski and Turán [1962] conjectured that $\pi(x; 4, 3) > \pi(x; 4, 1)$ holds 100% of the time in natural density sense. This was refuted, under GRH, by Kaczorowski [1992; 1995], who showed (conditionally) that $\{x : \pi(x; 4, 3) > \pi(x; 4, 1)\}$ does not have a natural density, and that its upper natural density is strictly less than 1.

Rubinstein and Sarnak [1994] studied the set

$$\{x : \pi(x; q, a) > \pi(x; q, b)\} \quad \text{where } a \not\equiv b \pmod{q} \text{ and } (a, q) = (b, q) = 1.$$

They showed, under GRH and the grand simplicity hypothesis (GSH) that this set has logarithmic density strictly between 0 and 1. Additionally, the logarithmic density is greater than $\frac{1}{2}$ if and only if a is a nonquadratic residue and b is a quadratic residue. In particular, no bias is present at all if both a and b are nonquadratic residues, as opposed to the sums of two squares analogue.

GSH asserts that the multiset of $\gamma \geq 0$ such that $L(\frac{1}{2} + i\gamma, \chi) = 0$, for χ running over primitive Dirichlet characters, is linearly independent over \mathbb{Q} ; here γ are counted with multiplicity. It implies Chowla's conjecture (since 0 is linearly dependent) and that zeros of $L(s, \chi)$ are simple. As opposed to Chowla, it is very hard to gather evidence for GSH, even for individual L -functions. However, see [Best and Trudgian 2015] for such evidence in the case of ζ . In the literature, this hypothesis also goes under the name linear independence (LI).

1D. Strong biases. Chebyshev's bias was studied in various settings and for various sets, e.g., [Ng 2000; Moree 2004; Fiorilli 2014a; 2014b; Devin 2020; 2021; Bailleul 2021], in particular for products of a fixed number of primes [Dummit et al. 2016; Ford and Sneed 2010; Meng 2018; Devin and Meng 2021].

As far as we are aware, Theorem 1.1 is the first instance where a set of integers of arithmetic interest — in this case sums of two squares — is shown to exhibit a complete Chebyshev's bias, that is, a bias that holds for a natural density-1 set of integers:

$$\#\{n \leq x : M(n; q, a) > M(n; q, b)\} = x(1 + o(1))$$

where $M(n; q, a)$ counts elements up to n in a set $M \subseteq \mathbb{N}$ that are congruent to a modulo q . A key issue here is the natural density: Meng [2020] has a related work about a bias that holds for a logarithmic density-1 set of integers (see Section 2E). Recently, Devin proposed a conjecture [2021, Conjecture 1.2] on a bias in logarithmic density 1. See Fiorilli [2014b; 2014a] for biases, in logarithmic density, that come arbitrarily close to 1, and Fiorilli and Jouve [2022] for complete biases in “Frobenius sets” of primes (that generalize arithmetic progressions).

We also mention a very strong bias was proved by Dummit, Granville and Kisilevsky [Dummit et al. 2016] who take Chebyshev's observation to a different direction. They show that substantially more than a quarter of the odd integers of the form pq up to x , with p, q both prime, satisfy $p \equiv q \equiv 3 \pmod{4}$.

In the function field setting, complete biases were established in various special situations (e.g., for low degree moduli) [Cha 2008, Corollary 4.4; Cha et al. 2016, Theorem 1.5; Devin and Meng 2021, Example 6]. See also the work of Porritt [2020] on which we elaborate in Section 2B.

2. Origin of the bias, computational evidence and a variation

2A. Review of the original bias. Fix a modulus q . All the constants below might depend on q . We give an informal explanation for the origin of the bias. It is instructive to start with the case of primes. By

orthogonality of characters,

$$\pi(x; q, a) - \pi(x; q, b) = \frac{1}{\phi(q)} \sum_{\chi_0 \neq \chi \pmod q} \overline{(\chi(a) - \chi(b))} \sum_{\substack{n \leq x \\ n \text{ is a prime}}} \chi(n).$$

The generating function of primes was studied by Riemann [2013], who showed that

$$\sum_{n \geq 1} \frac{\mathbf{1}_{n \text{ is a prime}}}{n^s} = \sum_{k \geq 1} \frac{\mu(k)}{k} \log \zeta(sk)$$

for $\Re s > 1$. Here μ is the Möbius function, ζ is the Riemann zeta function and the logarithm is chosen so that $\log \zeta(s)$ is real if s is real and greater than 1. More generally, given a Dirichlet character χ we have

$$\sum_{n \geq 1} \frac{\mathbf{1}_{n \text{ is a prime}} \chi(n)}{n^s} = \sum_{k \geq 1} \frac{\mu(k)}{k} \log L(sk, \chi^k).$$

We may also write this L -function identity in terms of arithmetic functions

$$\mathbf{1}_{n \text{ is a prime}} \chi(n) = \frac{\Lambda(n) \chi(n)}{\log n} + \sum_{k \geq 2} \frac{\mu(k) \Lambda(n^{1/k}) \chi(n)}{\log n} \mathbf{1}_{n \text{ is a } k\text{-th power}} \tag{2-1}$$

$$= \frac{\Lambda(n) \chi(n)}{\log n} - \frac{1}{2} \mathbf{1}_{n=p^2, p \text{ prime}} \chi^2(p) + \alpha(n) \chi(n), \tag{2-2}$$

where Λ is the von Mangoldt function and α is supported only on cubes and higher powers and its sum is negligible for all practical purposes. Under GRH we can show that (see [Rubinstein and Sarnak 1994, Lemma 2.1])

$$\sum_{n \leq x} \frac{\chi(n) \Lambda(n)}{\log n} = \frac{\sum_{n \leq x} \chi(n) \Lambda(n)}{\log x} + O\left(\frac{\sqrt{x}}{(\log x)^2}\right)$$

and (still under GRH) we can use the explicit formula to show that $\sum_{n \leq x} \chi(n) \Lambda(n)$ is typically of order $\asymp \sqrt{x}$, in the sense that

$$\frac{1}{X} \int_X^{2X} \left| \frac{\sum_{n \leq x} \chi(n) \Lambda(n)}{\sqrt{x}} \right|^2 dx \ll 1; \tag{2-3}$$

see [Montgomery and Vaughan 2007, Theorem 13.5]. Under linear independence, one can show that the random variable

$$e^{-y/2} \sum_{n \leq e^y} \chi(n) \Lambda(n)$$

has a limiting distribution with expected value 0 (here y is chosen uniformly at random between 0 and Y , and $Y \rightarrow \infty$). The exponential change of variables leads to the appearance of logarithmic density. To summarize, $(\log x / \sqrt{x}) \sum_{n \leq x} \chi(n) \Lambda(n) / \log n$ (with $x = e^y$) has expectation 0 and order of magnitude $\asymp 1$. The bias comes from the term $-\mathbf{1}_{n=p^2, p \text{ prime}} \chi^2(p) / 2$. Indeed,

$$-\frac{1}{2} \sum_{\substack{n \leq x \\ n=p^2, p \text{ prime}}} \chi^2(p) = -\frac{1}{2} \sum_{p \leq \sqrt{x}} \chi^2(p).$$

If χ is a nonreal character, χ^2 is nonprincipal and GRH guarantees this sum is $o(\sqrt{x}/\log x)$. However, if χ is real, this sum is of the same order of magnitude as $\sum_{n \leq x} \chi(n)\Lambda(n)/\log n$, namely it is

$$-\frac{1}{2} \sum_{n \leq x} \mathbf{1}_{n=p^2, p \text{ prime}} \chi^2(p) = -\frac{1}{2}(\pi(\sqrt{x}) + O(1)) \sim -\frac{\sqrt{x}}{\log x}$$

using the prime number theorem.

Rubinstein and Sarnak replaced $\sum_{n \leq x} \chi(n)\Lambda(n)/\log n$ with $\sum_{n \leq x} \chi(n)\Lambda(n)/\log x$ using partial summation. This is advantageous as we have a nice explicit formula for the sum of $\chi(n)\Lambda(n)$. However, one can work directly with $\chi(n)\Lambda(n)/\log n$, whose generating function is $\log L(s, \chi)$, and this was done by Meng [2018] in his work on Chebyshev’s bias for products of k primes. Meng’s approach is more flexible because it works even when the generating function has singularities which are not poles. So while $-L'(s, \chi)/L(s, \chi) = \sum_{n \geq 1} \Lambda(n)\chi(n)/n^s$ is meromorphic with simple poles at zeros of $L(s, \chi)$, which leads to the explicit formula by using the residue theorem, Meng’s approach can deal with $-\log L(s, \chi)$ directly although it does not have poles, rather it has essential singularities. Meng’s work applies in particular to $k = 1$ and $k = 2$, thus generalizing Rubinstein and Sarnak as well as Ford and Sneed [2010].

2B. The generating function of sums of two squares. Let us now return to sums of two squares. Let a, b be residues modulo q with $(a, q) = (b, q) = 1$ and $a \equiv b \equiv 1 \pmod{4, q}$. Orthogonality of characters shows

$$S(x; q, a) - S(x; q, b) = \frac{1}{\phi(q)} \sum_{\chi_0 \neq \chi \pmod{q}} \overline{(\chi(a) - \chi(b))} \sum_{n \leq x} \mathbf{1}_S(n) \chi(n). \tag{2-4}$$

We want to relate $\sum_{n \leq x} \mathbf{1}_S(n)\chi(n)$ to L -functions and their zeros, and obtain an analogue of the explicit formula for primes. The generating function of sums of two squares was studied by Landau [1908], who showed that for $\Re s > 1$,

$$\sum_{n \geq 1} \frac{\mathbf{1}_S(n)}{n^s} = \sqrt{\zeta(s)L(s, \chi_{-4})} H(s) \tag{2-5}$$

where H has analytic continuation to $\Re s > \frac{1}{2}$. Here the square root is chosen so that $\sqrt{\zeta(s)}$ and $\sqrt{L(s, \chi_{-4})}$ are real and positive for s real and greater than 1. This representation of the generating function plays a crucial role in the study of the distribution of sums of two squares; see e.g., [Gorodetsky and Rodgers 2021].

Later, Shanks [1964, page 78] and Flajolet and Vardi [1996, pages 7–9] (compare [Radziejewski 2014, equation (3); Gorodetsky and Rodgers 2021, Lemma 2.2]) proved independently the identity

$$\sum_{n \geq 1} \frac{\mathbf{1}_S(n)}{n^s} = \sqrt{\zeta(s)L(s, \chi_{-4})(1 - 2^{-s})^{-1}} \prod_{k \geq 1} \left(\frac{(1 - 2^{-2^k s})\zeta(2^k s)}{L(2^k s, \chi_{-4})} \right)^{2^{-k-1}}, \tag{2-6}$$

and their proof can yield an analogue of (2-6) with a twist by $\chi(n)$. Shanks and Flajolet and Vardi were interested in efficient computation of the constant K , and this identity leads to

$$K = \frac{1}{\sqrt{2}} \prod_{k \geq 1} \left(\frac{\zeta(2^k)(1 - 2^{-2^k})}{L(2^k, \chi_{-4})} \right)^{2^{-k-1}}.$$

Since both sides of (2-6) enjoy Euler products, this identity can be verified by checking it locally at each prime; one needs to check $p = 2$, $p \equiv 1 \pmod{4}$ and $p \equiv 3 \pmod{4}$ separately using (1-1). For the purpose of this paper we do not need the terms corresponding to $k > 1$ in (2-6). What we need is stated and proved in Lemma 3.5, namely that

$$F(s, \chi) := \sum_{n \geq 1} \frac{\mathbf{1}_S(n) \chi(n)}{n^s} = \sqrt{L(s, \chi) L(s, \chi \chi_{-4})} \sqrt[4]{\frac{L(2s, \chi^2)}{L(2s, \chi^2 \chi_{-4})}} G(s, \chi) \quad (2-7)$$

for G which is analytic and nonvanishing in $\Re s > \frac{1}{4}$ and bounded in $\Re s \geq \frac{1}{4} + \varepsilon$ for each $\varepsilon > 0$. The important feature of this formula is that it allows us to analytically continue $F(s, \chi)$ to the left of $\Re s = \frac{1}{2}$ (once we remove certain line segments), as opposed to (2-5) whose limit is $\Re s > \frac{1}{2}$. See the discussion at the end Section 3B.

Recently, a formula very similar to (2-7) was used by Porritt [2020] in his study of character sums over polynomials with k prime factors, and k tending to ∞ . We state his formula in the integer setting. Let Ω be the additive function counting prime divisors with multiplicity. He showed that, for complex z with $|z| < 2$, we have [Porritt 2020, (4)]

$$\sum_{n \geq 1} \frac{z^{\Omega(n)} \chi(n)}{n^s} = L(s, \chi)^z L(2s, \chi^2)^{(z^2-z)/2} E_z(s, \chi)$$

for $E_z(s, \chi)$ which is analytic in $\Re s > \max\{\frac{1}{3}, \log_2 |z|\}$. He then proceeds to apply a Selberg–Delange type analysis, leading to an explicit formula for a polynomial analogue of $\sum_{n \leq x, \Omega(n)=k} \chi(n)$ where k grows like $a \log \log x$ for $a \in (0, 2^{1/2})$ (in the polynomial world, q and $q^{1/2}$ replace 2 and $2^{1/2}$, where q is the size of the underlying finite field). His results show a strong Chebyshev’s bias once $a > 1.2021 \dots$ [Porritt 2020, Theorem 4].

2C. Analyzing singularities. We shall analyze each of the sums in (2-4). We first observe that we do not need to analyze the sums corresponding to χ or $\chi \chi_{-4}$ being principal, because these characters do not contribute to (2-4) (as $\chi_0(a) = \chi_0(b)$).

Assume GRH and let χ be a nonprincipal character such that $\chi \chi_{-4}$ is also nonprincipal. We apply a truncated Perron’s formula to $\sum_{n \leq x} \mathbf{1}_S(n) \chi(n)$ (Corollary 3.3). We then want to shift the contour to $\Re s = \frac{1}{2} - c$ ($c = \frac{1}{10}$, say) and apply the residue theorem. We cannot do it, because $L(s, \chi)$ and $L(s, \chi \chi_{-4})$ have zeros on $\Re s = \frac{1}{2}$ so $F(s, \chi)$, which involves the square root of $L(s, \chi) L(s, \chi \chi_{-4})$, cannot be analytically continued to $\Re s \geq \frac{1}{2} - c$. Let us analyze the zeros and poles, in the half-plane $\Re s > \frac{1}{4}$, of $L(s, \chi)$, $L(s, \chi \chi_{-4})$, $L(2s, \chi^2)$ and $L(2s, \chi^2 \chi_{-4})$. These are the functions which appear in (2-7) and dictate the region to which we may analytically continue $F(s, \chi)$:

- We have zeros of $L(s, \chi)$, $L(s, \chi \chi_{-4})$ on $\Re s = \frac{1}{2}$ (only) by GRH. We do not have poles at $s = 1$ because we assume χ , $\chi \chi_{-4}$ are nonprincipal.
- Under GRH, $L(2s, \chi^2)$ and $L(2s, \chi^2 \chi_{-4})$ have no zeros in $\Re s > \frac{1}{4}$.

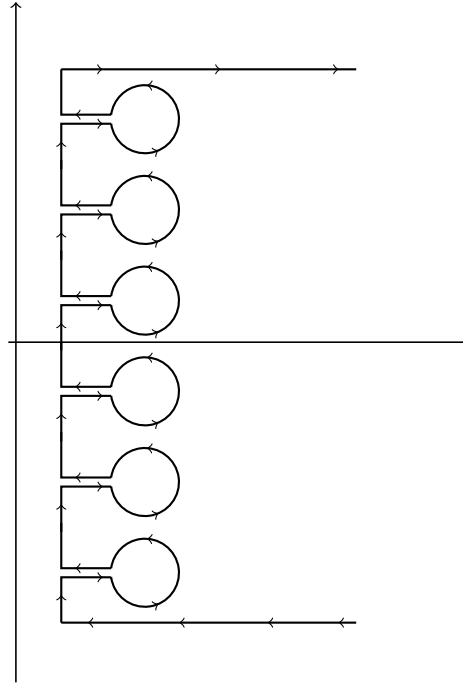

Figure 1. Contour of integration.

- If χ^2 is principal then $L(2s, \chi^2)$ has a simple pole at $s = \frac{1}{2}$. Similarly, if $\chi^2\chi_{-4}$ is principal then $L(2s, \chi^2\chi_{-4})$ has a simple pole at $s = \frac{1}{2}$. If χ^2 and $\chi^2\chi_{-4}$ are nonprincipal then these L -functions have no poles.

We call these zeros and poles “singularities of F ”. They all lie on $\Re s = \frac{1}{2}$. We construct an open set A_χ by taking the half-plane $\Re s > \frac{1}{4}$ and removing the segments $\{\sigma + it : \frac{1}{4} < \sigma \leq \frac{1}{2}\}$ for every singularity $\frac{1}{2} + it$. This domain is simply connected and $L(s, \chi)$, $L(s, \chi\chi_{-4})$, $L(2s, \chi^2)$ and $L(2s, \chi^2\chi_{-4})$ have no poles or zeros there. Hence, they have well-defined logarithms there and we may analytically continue $F(s, \chi)$ to A_χ .

Although we cannot literally shift the contour to the left of $\Re s = \frac{1}{2}$, we can move to a contour which stays in A_χ and is to the left of $\Re s = \frac{1}{2}$ “most of the time”. Specifically, we shall use truncated Hankel loop contours going around the singularities, joined to each other vertically on $\Re s = \frac{1}{2} - c$, as in Meng [2018; 2020]. The precise contour is described in Section 3D. See Figure 1 for depiction. A truncated Hankel loop contour around a singularity ρ of $F(s, \chi)$ is a contour \mathcal{H}_ρ traversing the path depicted in Figure 2. It is parametrized in (3-13).

Given a character χ and a singularity ρ of $F(s, \chi)$ we let

$$f(\rho, \chi, x) := \frac{1}{2\pi i} \int_{\mathcal{H}_\rho} F(s, \chi) x^s \frac{ds}{s}$$

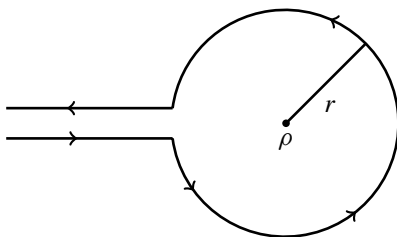

Figure 2. Truncated Hankel loop contour around ρ with radius r .

be the Hankel contour integral around ρ . By analyticity, the value of $f(\rho, \chi, x)$ is independent of r (once r is small enough) and for our purposes we choose $r = o(1/\log x)$. We end up obtaining

$$\sum_{n \leq x} \mathbf{1}_{S(n)} \chi(n) \approx \sum_{\substack{\rho: L(\rho, \chi) L(\rho, \chi \chi_{-4}) = 0 \\ \text{or } \rho = 1/2}} f(\rho, \chi, x). \quad (2-8)$$

See [Lemma 3.10](#) for a statement formalizing (2-8) (in practice we sum only over zeros up to a certain height). If $F(s, \chi) \sim C(s - \rho)^m$ asymptotically as $s \rightarrow \rho^+$ (i.e., as $s - \rho$ tends to 0 along the positive part of the real line) for one of the singularities ρ , it can be shown that

$$f(\rho, \chi, x) \sim \frac{C}{\Gamma(-m)} \frac{x^\rho}{\rho} (\log x)^{-1-m} \quad (2-9)$$

as $x \rightarrow \infty$. An informal way to see this is

$$\int_{\mathcal{H}_\rho} F(s, \chi) x^s \frac{ds}{s} \approx \frac{C}{\rho} \int_{\mathcal{H}_\rho} (s - \rho)^m x^s ds = \frac{C x^\rho}{\rho} (\log x)^{-1-m} \int_{(\log x)(\mathcal{H}_\rho - \rho)} z^m e^z dz$$

and the last integral gives (2-9) by Hankel's original computation [[Tenenbaum 2015](#), Theorem II.0.17].² In particular, from analyzing $\sqrt{L(s, \chi)L(s, \chi \chi_{-4})}$ we have

$$f(\rho, \chi, x) \sim c_\rho \frac{x^\rho}{\rho} (\log x)^{-1-m_\rho/2}, \quad c_\rho = \frac{\lim_{s \rightarrow \rho^+} F(s, \chi)(s - \rho)^{-m_\rho/2}}{\Gamma(-m_\rho/2)},$$

for any given $\rho \neq \frac{1}{2}$ where m_ρ is the multiplicity of ρ in $L(s, \chi)L(s, \chi \chi_{-4})$. As $m_\rho \geq 1$, we are led to think of $\sum_{\rho \neq 1/2} f(\rho, \chi, x)$ as a quantity of order $\asymp \sqrt{x}(\log x)^{-3/2}$. However, we are not able to use (2-9) in order to bound $\sum_{\rho \neq 1/2} f(\rho, \chi, x)$ efficiently. We proceed via a different route and show

$$\frac{1}{X} \int_X^{2X} \left| \frac{\sum_{\rho \neq 1/2} f(\rho, \chi, x)}{\sqrt{x}(\log x)^{-3/2}} \right|^2 dx \ll 1 \quad (2-10)$$

without making use of (2-9). It follows that $\sum_{\rho \neq 1/2} f(\rho, \chi, x) \ll \sqrt{x}(\log x)^{-3/2}$ most of the time. This estimate is analogous to (2-3) and its proof is similar too. We believe this sum is $\ll_\epsilon \sqrt{x}(\log x)^{\epsilon-3/2}$ always but are not able to show this. This is similar to how GRH can show $\sum_{n \leq x} \Lambda(n) \chi(n) \ll \sqrt{x}(\log x)^2$,

²To justify the first passage it suffices to show $\int_{\mathcal{H}_\rho} |G(s)x^s| |ds| = o(x^{\Re \rho} (\log x)^{-1-m})$ for $G(s) = F(s, \chi)/s - C(s - \rho)^m/\rho$, which is possible in our case.

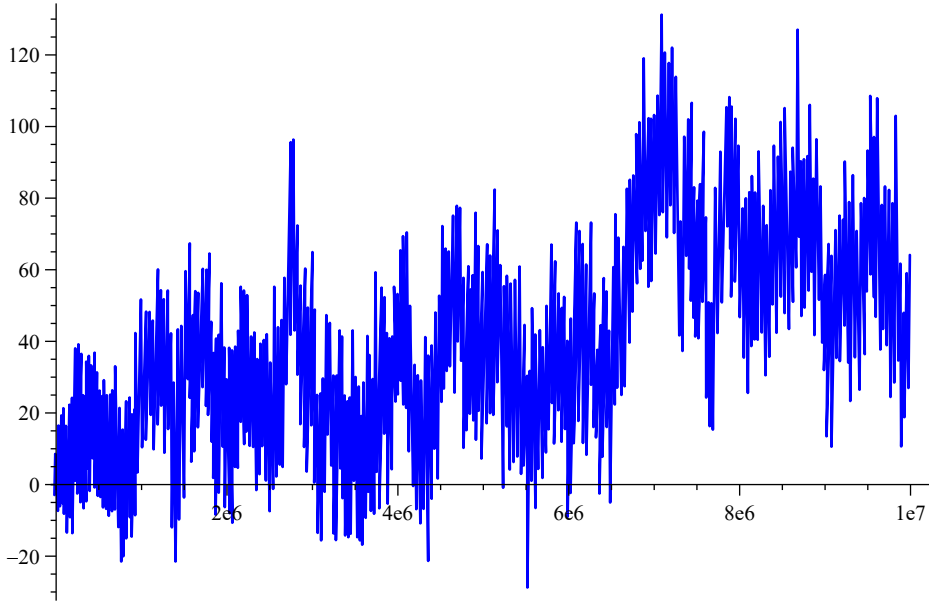

Figure 3. Graph of $S(x; 3, 1) - S(x; 3, 2)$ up to 10^7 .

but the true size in this question is expected to be $\ll_{\epsilon} \sqrt{x}(\log x)^{\epsilon}$. Here one should think of $f(\rho, \chi, x)$ as an analogue of the expression $-x^{\rho}/\rho$ from the explicit formula.

Finally, let us analyze the contribution of the (possible) singularity at $\frac{1}{2}$. If $L(\frac{1}{2}, \chi)L(\frac{1}{2}, \chi\chi_{-4}) = 0$ or if $\chi^2\chi_{-4}$ is principal we can show (e.g., using (2-9)) that $f(\frac{1}{2}, \chi, x) \ll \sqrt{x}(\log x)^{-5/4}$; see Lemma 4.4. The constant $\frac{5}{4}$ arises from analyzing $\sqrt{L(s, \chi)L(s, \chi\chi_{-4})}$ and $\sqrt[4]{L(2s, \chi^2)/L(2s, \chi^2\chi_{-4})}$ and applying (2-9) with $m \geq \frac{1}{4}$. It follows from (2-8) and (2-10) that

$$\frac{1}{X} \int_X^{2X} \left| \frac{\sum_{n \leq x} \mathbf{1}_S(n)\chi(n)}{\sqrt{x}(\log x)^{-5/4}} \right|^2 dx \ll 1$$

unless χ^2 is principal and $L(\frac{1}{2}, \chi)L(\frac{1}{2}, \chi\chi_{-4}) \neq 0$. This remaining case leads to the bias. Indeed, we have

$$F(s, \chi) \sim C(s - \frac{1}{2})^{-1/4}$$

as $s \rightarrow \frac{1}{2}^+$ because of the fourth root in $\sqrt[4]{L(2s, \chi^2)}$, and this allows us to show (Lemma 4.5) that

$$f(\frac{1}{2}, \chi, x) \asymp \sqrt{x}(\log x)^{-3/4}.$$

This is bigger than the typical contribution of all the other singularities by $(\log x)^{1/2}$. In one line, the bias comes from the fact that the value of m in the asymptotic relation $F(s, \chi) \sim C(s - \rho)^m$ ($s \rightarrow \rho^+$, ρ a singularity) is minimized when χ^2 is principal, $\rho = \frac{1}{2}$ and $L(\frac{1}{2}, \chi)L(\frac{1}{2}, \chi\chi_{-4}) \neq 0$, in which case $m = -\frac{1}{4}$.

		b						
	1	4	2	7	8	11	13	14
	1		1.427	9.698	1.427	9.931	9.698	9.931
	4		1.427	9.698	1.427	9.931	9.698	9.931
	2			8.271		8.504	8.271	8.504
a	7				-8.271	0.233		0.233
	11						-0.233	
	13							0.233

Table 1. Values of $C_{15,a,b}$.

		b						
	1	4	2	7	8	11	13	14
	1		93.99	99.99	86.12	99.98	99.99	99.99
	4		96.28	99.97	90.72	99.99	99.99	99.96
	2			99.90		99.85	99.93	99.90
a	7				0.03	57.99		57.99
	8					99.52	99.96	99.99
	11						40.19	
	13							59.23

Table 2. Percentage of $n \leq 10^7$ with $S(n; 15, a) > S(n; 15, b)$.

2D. Computational evidence. We examine the bias for $q \in \{3, 5, 15\}$. For $q = 3$ we only have two relevant residues modulo q , namely 1 mod 3 (quadratic), and 2 mod 3 (nonquadratic). We have $L(\frac{1}{2}, \chi) \approx 0.480$ for the unique nonprincipal Dirichlet character modulo 3 and $L(\frac{1}{2}, \chi\chi_{-4}) \approx 0.498$. Under GRH, [Corollary 1.3](#) predicts $S(x; 3, 1) > S(x; 3, 2)$ for almost all x . Up to 10^8 , 96.8% of the time $S(x; 3, 1) > S(x; 3, 2)$. See [Figure 3](#) for the (quite oscillatory) graph of $S(x; 3, 1) - S(x; 3, 2)$ up to 10^7 .

For $q = 5$ we have 4 possible residues: 1 and 4 mod 5, both quadratic, and 2 and 3 mod 5, nonquadratic. We have $L(\frac{1}{2}, \chi) \approx 0.231$ and $L(\frac{1}{2}, \chi\chi_{-4}) \approx 1.679$ for χ , the unique nonprincipal quadratic character modulo 5. [Corollary 1.3](#) predicts, under GRH, that $S(x; 5, 1)$ and $S(x; 5, 4)$ are almost always greater than $S(x; 5, 2)$ and $S(x; 5, 3)$. The value of $C_{5,a,b}$ is simply $\chi(a) - \chi(b)$ times $(1 + 1/\sqrt{2})^{-1/2} \sqrt{L(\frac{1}{2}, \chi)L(\frac{1}{2}, \chi\chi_{-4})}$. For $(a, b) \in \{(1, 2), (1, 3), (4, 2), (4, 3)\}$ its value is ≈ 0.7309 , since $\chi(a) = 1$ and $\chi(b) = -1$. For $(a, b) \in \{(1, 2), (1, 3), (4, 2), (4, 3)\}$, we find that the percentage of integers $n \leq 10^7$ with $S(n; 5, a) > S(n; 5, b)$ are 96.1%, 95.2%, 95.3% and 94.6%, respectively.

For $q = 15$ we have the quadratic residues 1, 4 and the nonquadratic residues 2, 7, 8, 11, 13, 14. We expect $S(x; 5, a) - S(x; 5, b)$ to be positively biased for $a \in \{1, 4\}$ and $b \in \{2, 7, 8, 11, 13, 14\}$. Moreover, we expect a bias also for $S(x; 5, a) - S(x; 5, b)$ whenever $a \neq b \in \{2, 7, 8, 11, 13, 14\}$ and $a/b \not\equiv 4 \pmod{15}$, which means $(a, b) \neq (2, 8), (7, 13), (11, 14)$. The direction of the bias in this case is harder to predict. See [Table 1](#) for a table of the values of $C_{15,a,b}$ and [Table 2](#) for $\#\{n \leq 10^7 : S(n; 15, a) > S(n; 15, b)\}/10^7$ (in percentages). We omit pairs with $a \geq b$ due to symmetry and pairs a, b with a/b being a quadratic residue.

We see that the two tables are correlated. This is not a coincidence: the proof of [Theorem 1.1](#) actually shows that $S(x; q, a) - S(x; q, b) = \phi(q)^{-1} C_q C_{q,a,b} \sqrt{x}/(\log x)^{3/4} + E(x)$ where C_q is positive constant depending only on q and $E(x)$ is a function which, on average, is smaller than $\sqrt{x}/(\log x)^{3/4}$. Concretely, $(1/X) \int_X^{2X} |E(x)|^2 dx \ll X/(\log X)^{5/2}$. So, for most values of x , $S(x; q, a) - S(x; q, b)$ is proportional to $C_{q,a,b}$.

2E. Martin’s conjecture. Let ω be the additive function counting prime divisors (without multiplicity). Meng [\[2020\]](#) states a conjecture of Greg Martin, motivated by numerical data, saying that

$$\left\{ x : \sum_{\substack{n \leq x \\ n \equiv 1 \pmod 4}} \omega(n) < \sum_{\substack{n \leq x \\ n \equiv 3 \pmod 4}} \omega(n) \right\}$$

contains all sufficiently large x . Meng assumed GRH and GSH to prove that this set has logarithmic density 1. He also obtains results for other moduli under Chowla’s conjecture, and studies an analogous problem with the completely additive function Ω . Meng [\[2020, Remark 4\]](#) writes: “In order to prove the full conjecture, one may need to formulate new ideas and introduce more powerful tools to bound the error terms of the summatory functions”. We are able to prove a natural density version of Meng’s result, making progress towards Martin’s conjecture. We do not assume GSH.

Theorem 2.1. Fix a positive integer q . Assume that GRH holds for the Dirichlet L -functions $L(s, \chi)$ for all Dirichlet character χ modulo q . Then, whenever a, b satisfy $(a, q) = (b, q) = 1$ and

$$D_{q,a,b} := \sum_{\substack{\chi \pmod q \\ \chi^2 = \chi_0}} (\chi(a) - \chi(b)) L\left(\frac{1}{2}, \chi\right) > 0 \tag{2-11}$$

we have, as $x \rightarrow \infty$,

$$\#\left\{ n \leq x : \sum_{\substack{m \leq n \\ m \equiv a \pmod q}} \omega(m) < \sum_{\substack{m \leq n \\ m \equiv b \pmod q}} \omega(m) \right\} = x(1 + o(1))$$

and

$$\#\left\{ n \leq x : \sum_{\substack{m \leq n \\ m \equiv a \pmod q}} \Omega(m) > \sum_{\substack{m \leq n \\ m \equiv b \pmod q}} \Omega(m) \right\} = x(1 + o(1))$$

The proof is given in [Section 6](#). If a is a quadratic residue modulo q and b is not, a sufficient condition for $D_{q,a,b}$ to be positive is Chowla’s Conjecture.

3. Preparatory lemmas

Given a Dirichlet character χ modulo q we write

$$F(s, \chi) = \sum_{n \in S} \frac{\chi(n)}{n^s} = \prod_{p \not\equiv 3 \pmod 4} (1 - \chi(p)p^{-s})^{-1} \prod_{p \equiv 3 \pmod 4} (1 - \chi^2(p)p^{-2s})^{-1}.$$

This converges absolutely for $\Re s > 1$. For $\Re s = 1$ (or smaller) it does not, because such convergence implies $\sum_{p \neq 3 \bmod 4, p \nmid q} 1/p$ converges. Observe that $F(s, \chi)$ does not vanish for $\Re s > 1$.

We shall use the convention where σ and t denote the real and complex parts of $s \in \mathbb{C}$.

3A. Perron.

Lemma 3.1 (effective Perron's formula [Tenenbaum 2015, Theorem II.2.3]). *Let $F(s) = \sum_{n \geq 1} a_n/n^s$ be a Dirichlet series with abscissa of absolute convergence $\sigma_a < \infty$. For $\kappa > \max\{0, \sigma_a\}$, $T \geq 1$ and $x \geq 1$ we have*

$$\sum_{n \leq x} a_n = \frac{1}{2\pi i} \int_{\kappa-iT}^{\kappa+iT} F(s)x^s \frac{ds}{s} + O\left(x^\kappa \sum_{n \geq 1} \frac{|a_n|}{n^\kappa(1+T|\log(x/n)|)}\right), \quad (3-1)$$

with an absolute implied constant.

This lemma leads to the following, which is a variation on [Tenenbaum 2015, Corollary II.2.4].

Corollary 3.2. *Suppose $|a_n| \leq 1$. Let $F(s) = \sum_{n \geq 1} a_n/n^s$. Then, for $x, T \gg 1$,*

$$\sum_{n \leq x} a_n = \frac{1}{2\pi i} \int_{1+1/\log x-iT}^{1+1/\log x+iT} F(s)x^s \frac{ds}{s} + O\left(1 + \frac{x \log x}{T}\right), \quad (3-2)$$

with an absolute implied constant.

Proof. Since $|a_n| \leq 1$ we have $\sigma_a \leq 1$ so that we may apply Lemma 3.1 with $\kappa = 1 + 1/\log x$. The contribution of $n \leq x/2$ to the error term is

$$\ll x \sum_{n \leq x/2} \frac{1}{Tn} \ll \frac{x \log x}{T}.$$

The contribution of $n \geq 2x$ to the error is

$$\ll x \sum_{k \geq 1} \sum_{n \in [2^k x, 2^{k+1} x)} \frac{1}{n^\kappa T k} \ll x \sum_{k \geq 1} \frac{2^{-k/\log x}}{T} \ll \frac{x \log x}{T}.$$

Finally, if $n \in (x/2, 2x)$, the contribution is

$$\ll \sum_{n \in (x/2, 2x)} \frac{1}{1+T|\log(x/n)|} \ll 1 + \frac{x \log x}{T}$$

where the second inequality follows e.g., by the argument in [Tenenbaum 2015, Corollary II.2.4]. \square

As a special case of this corollary we have

Corollary 3.3. *Let χ be a Dirichlet character. We have*

$$\sum_{\substack{n \leq x \\ n \in S}} \chi(n) = \frac{1}{2\pi i} \int_{1+1/\log x-iT}^{1+1/\log x+iT} F(s, \chi)x^s \frac{ds}{s} + O\left(1 + \frac{x \log x}{T}\right). \quad (3-3)$$

Remark 3.4. Since $|F(s, \chi)| \leq \sum_{n \geq 1} n^{-1-1/\log x} \ll \log x$ when $\Re s = 1 + 1/\log x$, we see that perturbing the parameter T (appearing in the range of integration) by $O(1)$ incurs an error of $O(x \log x/T)$ which is absorbed in the existing error term.

3B. Analytic continuation. Given a Dirichlet series $G(s)$ associated with a multiplicative function $g(n)$, which converges absolutely for $\Re s > 1$ and does not vanish there, we define the k -th root of G as

$$G^{1/k}(s) = \exp\left(\frac{\log G(s)}{k}\right)$$

for each positive integer k , where the logarithm is chosen so that $\arg G(s) \rightarrow 0$ as $s \rightarrow \infty$. The function $G^{1/k}$ is also a Dirichlet series, since

$$G^{1/k}(s) = \prod_p \exp\left(\frac{\log \sum_{i \geq 0} g(p^i)/p^{is}}{k}\right).$$

Lemma 3.5. Let χ be a Dirichlet character modulo q . We have, for $\Re s > 1$,

$$F(s, \chi) = \sqrt{L(s, \chi)L(s, \chi\chi_{-4})} \sqrt[4]{\frac{L(2s, \chi^2)}{L(2s, \chi^2\chi_{-4})}} G(s, \chi)$$

for G which is analytic and nonvanishing in $\Re s > \frac{1}{4}$ and bounded in $\Re s \geq \frac{1}{4} + \varepsilon$. If χ is real then

$$G\left(\frac{1}{2}, \chi\right) = \left(1 - \frac{\chi(2)}{\sqrt{2}}\right)^{-1/2} \left(1 - \frac{\mathbf{1}_{2 \nmid q}}{2}\right)^{1/4} \prod_{\substack{p \equiv 3 \pmod{4} \\ p \nmid q}} \left(1 - \frac{1}{p^2}\right)^{-1/4}. \tag{3-4}$$

Proof. We have, for $\Re s > 1$,

$$\log G(s, \chi) = \log F(s, \chi) - \frac{\log L(s, \chi)}{2} - \frac{\log L(s, \chi\chi_{-4})}{2} + \frac{\log L(2s, \chi^2\chi_{-4})}{4} - \frac{\log L(2s, \chi^2)}{4} \tag{3-5}$$

$$= \frac{-\log(1 - \chi(2)2^{-s})}{2} + \frac{\log(1 - \chi^2(2)2^{-2s})}{4} + \sum_{p \equiv 3 \pmod{4}} g_p(s, \chi) \tag{3-6}$$

for

$$g_p(s, \chi) = \frac{-\log(1 - \chi^2(p)p^{-2s})}{2} + \frac{\log(1 - \chi^2(p)p^{-2s}) - \log(1 + \chi^2(p)p^{-2s})}{4}.$$

Each g_p is analytic in $\Re s > 0$. Fix $c > 0$. For $\Re s \geq c$ we have

$$g_p(s, \chi) = \frac{\chi^4(p)}{4} p^{-4s} + O_c(p^{-6c}) = O_c(p^{-4c})$$

by Taylor expanding $\log(1 + x)$. In particular, if $c = \frac{1}{4} + \varepsilon$ we have

$$\left| \sum_{p \equiv 3 \pmod{4}} g_p(s, \chi) \right| \ll \sum_{p \equiv 3 \pmod{4}} p^{-4c} \ll \sum_{n \geq 1} n^{-1-4\varepsilon} < \infty$$

and so G may be extended to $\Re s > \frac{1}{4}$ via (3-6). As each g_p is analytic in $\Re s > \frac{1}{4}$, and $\sum_{p \equiv 3 \pmod 4} g_p(s, \chi)$ converges uniformly in $\Re s \geq \frac{1}{4} + \varepsilon$ for every choice of $\varepsilon > 0$, it follows that $\log G$ is analytic in $\Re s > \frac{1}{4}$ and so is G . The formula for $G(\frac{1}{2}, \chi)$ for real χ follows from evaluating g_p at $s = \frac{1}{2}$ and observing $\chi^2 = \chi_0$. □

Assuming GRH for $L(s, \chi)$ where χ is nonprincipal, $L(s, \chi)^{1/k}$ may be analytically continued to the region

$$\mathbb{C} \setminus (\{\sigma + it : L(\frac{1}{2} + it, \chi) = 0 \text{ and } \sigma \leq \frac{1}{2}\} \cup \{\sigma : \sigma \leq -1\}) \tag{3-7}$$

and is nonzero there (because of trivial zeros of $L(s, \chi)$ we have to remove $\{\sigma : \sigma \leq -1\}$). For χ principal we have a singularity at $s = 1$ and so $L(s, \chi)^{1/k}$ may be analytically continued to

$$\mathbb{C} \setminus (\{\sigma + it : L(\frac{1}{2} + it, \chi) = 0 \text{ and } \sigma \leq \frac{1}{2}\} \cup \{\sigma : \sigma \leq 1\}). \tag{3-8}$$

Hence, given χ which is nonprincipal and such that $\chi\chi_{-4}$ is nonprincipal, we have the following. Under GRH for $\chi, \chi\chi_{-4}, \chi^2$ and $\chi^2\chi_{-4}$, we may continue $F(s, \chi)$ analytically to

$$\{s \in \mathbb{C} : \Re s > \frac{1}{4}\} \setminus \{\sigma + it : L(\frac{1}{2} + it, \chi)L(\frac{1}{2} + it, \chi\chi_{-4}) = 0 \text{ and } \sigma \leq \frac{1}{2}\} \tag{3-9}$$

if both χ^2 and $\chi^2\chi_{-4}$ are nonprincipal; otherwise we may continue it to

$$\{s \in \mathbb{C} : \Re s > \frac{1}{4}\} \setminus (\{\sigma + it : L(\frac{1}{2} + it, \chi)L(\frac{1}{2} + it, \chi\chi_{-4}) = 0 \text{ and } \sigma \leq \frac{1}{2}\} \cup \{\sigma : \sigma \leq \frac{1}{2}\}). \tag{3-10}$$

3C. L -function estimates. We quote three classical bounds on L -functions from the book of Montgomery and Vaughan [2007].

Lemma 3.6 [Montgomery and Vaughan 2007, Theorem 13.18 and Example 8 in Section 13.2.1]. *Let χ be a Dirichlet character. Under GRH for $L(s, \chi)$, there exists a constant A depending only on χ such that the following holds. Uniformly for $\sigma \geq \frac{1}{2}$ and $|t| \geq 1$,*

$$|L(s, \chi)| \leq \exp\left(A \frac{\log(|t| + 4)}{\log \log(|t| + 4)}\right).$$

Lemma 3.7 [Montgomery and Vaughan 2007, Theorem 13.23]. *Let χ be a Dirichlet character. Suppose $|t| \gg 1$. Under GRH for $L(s, \chi)$, there exists a constant A depending only on χ such that the following holds. Uniformly for $\sigma \geq \frac{1}{2} + 1/\log \log(|t| + 4)$ and $|t| \geq 1$,*

$$\left| \frac{1}{L(s, \chi)} \right| \leq \exp\left(A \frac{\log(|t| + 4)}{\log \log(|t| + 4)}\right).$$

Lemma 3.8 [Montgomery and Vaughan 2007, Corollary 13.16 and Example 6(c) in Section 13.2.1]. *Let $\sigma \in (\frac{1}{2}, 1)$ be fixed. Let χ be a primitive Dirichlet character. We have, as $|t| \rightarrow \infty$,*

$$|\log L(s, \chi)| \ll_{\sigma} \frac{(\log(|t| + 4))^{2-2\sigma}}{\log \log(|t| + 4)}.$$

The following is a consequence of the functional equation.

Lemma 3.9 [Montgomery and Vaughan 2007, Corollary 10.10]. *Let χ be a Dirichlet character and $\varepsilon \in (0, 1)$. We have $|L(s, \chi)| \asymp |L(1 - s, \bar{\chi})|(|t| + 4)^{1/2 - \sigma}$ uniformly for $\varepsilon \leq \sigma \leq \frac{1}{2}$ and $|t| \geq 1$, where the implied constants depend only on χ and ε .*

These four lemmas are originally stated for primitive characters. However, if χ is induced from a primitive character ψ , then in $\Re s > 0$ the ratio $L(s, \chi)/L(s, \psi)$ is equal to the finite Euler product $\prod_{p:\chi(p)=0}(1 - \psi(p)/p^s)$. This product is bounded away from 0 and from ∞ when $\Re s \geq \varepsilon$, so we can convert results for $L(s, \psi)$ to results for $L(s, \chi)$ as long as we restrict our attention to $\sigma \geq \varepsilon$.

3D. Contour choice. Let χ be a nonprincipal Dirichlet character modulo q . Fix $c \in (0, \frac{1}{8})$ (say, $c = \frac{1}{10}$). Let $T \gg 1$.

We want to use Cauchy’s integral theorem to shift the vertical contour appearing in (3-3) to the left of $\Re s = \frac{1}{2}$ (namely to $\Re s = \frac{1}{2} - c$), at the “cost” of certain horizontal contributions. As we want to avoid zeros of $L(s, \chi)L(s, \chi\chi_{-4})$ and poles and zeros of $L(2s, \chi^2)/L(2s, \chi^2\chi_{-4})$ (which by GRH can only occur at $s = \frac{1}{2}$), we will use (truncated) Hankel loop contours to go around the relevant zeros and poles; the integrals over these loops will be the main contribution to our sum. It will also be convenient for $\frac{1}{2} - iT$ and $\frac{1}{2} + iT$ to avoid zeros of $L(s, \chi)L(s, \chi\chi_{-4})$; this is easy due to Remark 3.4, showing that changing T by $O(1)$ does not increase the error term arising from applying Perron’s (truncated) formula. We replace the range $[1 + 1/\log x - iT, 1 + 1/\log x + iT]$ with $[1 + 1/\log x - iT'', 1 + 1/\log x + iT']$ where $T - 1 \leq T', T'' \leq T$ and

$$L(\frac{1}{2} + it, \chi)L(\frac{1}{2} + it, \chi\chi_{-4}) \neq 0$$

for every $t \in [T', T) \cup (-T, -T'']$. Let

$$\gamma_1 < \gamma_2 < \dots < \gamma_m \tag{3-11}$$

be the imaginary parts of the zeros of $L(s, \chi)L(s, \chi\chi_{-4})$ on $\sigma = \frac{1}{2}$ with $t \in (-T, T)$ (without multiplicities), and, if either χ^2 or $\chi^2\chi_{-4}$ is principal, we include the number 0 (if it is not there already). Let $r \in (0, 1)$ be a parameter that will tend to 0 later. Consider the contour

$$I_1 \cup \bigcup_{j=1}^m (J_j \cup \mathcal{H}_{1/2+i\gamma_j}) \cup J_{m+1} \cup I_2 \tag{3-12}$$

where I_1 traverses the horizontal segment

$$I_1 = \left\{ \sigma - iT'' : \frac{1}{2} - c \leq \sigma \leq 1 + \frac{1}{\log x} \right\}$$

from right to left, I_2 traverses the horizontal segment

$$I_2 = \left\{ \sigma + iT' : \frac{1}{2} - c \leq \sigma \leq 1 + \frac{1}{\log x} \right\}$$

from left to right, J_j traverses the following vertical segment from its bottom point to the top:

$$J_j = \left\{ \frac{1}{2} - c + it : \gamma_{j-1} \leq t \leq \gamma_j \right\}$$

where

$$\gamma_0 := -T'', \quad \gamma_{m+1} := T',$$

and finally each \mathcal{H}_ρ traverses the following truncated Hankel loop contour in an anticlockwise fashion:

$$\begin{aligned} \{s \in \mathbb{C} : \frac{1}{2} - c \leq \Re s \leq \frac{1}{2} - r, \Im s = \Im \rho, \arg(s - \rho) = -\pi\} \\ \cup \{s \in \mathbb{C} : |s - \rho| = r, -\pi < \arg(s - \rho) < \pi\} \\ \cup \left\{ \frac{1}{2} - c \leq \Re s \leq \frac{1}{2} - r, \Im s = \Im \rho, \arg(s - \rho) = \pi \right\} \end{aligned} \quad (3-13)$$

where in our case $c = \frac{1}{10}$ and $r = o(1/\log x)$. We refer the reader to [Tenenbaum 2015, pages 179–180] for background on the Hankel contour and its truncated version. If r is small enough, the contour in (3-12) does not intersect itself.

If both χ^2 and $\chi^2\chi_{-4}$ are nonprincipal characters and the corresponding L -functions satisfy GRH observe $\sqrt[4]{L(2s, \chi^2)/L(2s, \chi^2\chi_{-4})}$ is analytic in $\Re s > \frac{1}{2} - 2c > \frac{1}{4}$ and so is $F(s, \chi)$ by Lemma 3.5.

If χ^2 is principal then $\chi^2\chi_{-4}$ cannot be principal. Similarly, if $\chi^2\chi_{-4}$ is principal then χ is a nonreal Dirichlet character of order 4 and χ^2 cannot be principal. In both cases, $\sqrt[4]{L(2s, \chi^2)/L(2s, \chi^2\chi_{-4})}$ has an algebraic singularity at $s = \frac{1}{2}$, which we avoid already as we inserted 0 to the list (3-11) if it is not there already.

In any case, by Cauchy’s integral theorem,

$$\begin{aligned} \frac{1}{2\pi i} \int_{1+1/\log x - iT''}^{1+1/\log x + iT'} F(s, \chi) x^s \frac{ds}{s} \\ = \frac{1}{2\pi i} \left(\int_{I_1} + \sum_{j=1}^m \left(\int_{J_j} + \int_{\mathcal{H}_{1/2+i\gamma_j}} \right) + \int_{J_{m+1}} + \int_{I_2} \right) F(s, \chi) x^s \frac{ds}{s}. \end{aligned} \quad (3-14)$$

Lemma 3.10. *Let χ be a nonprincipal Dirichlet character. Assume GRH holds for the four characters*

$$\chi, \quad \chi\chi_{-4}, \quad \chi^2, \quad \chi^2\chi_{-4}. \quad (3-15)$$

Let $c \in (0, \frac{1}{8})$ be a fixed constant. Let $T \gg 1$. We have

$$\begin{aligned} \sum_{\substack{n \leq x \\ n \in S}} \chi(n) = \sum_{j=1}^m \frac{1}{2\pi i} \int_{\mathcal{H}_{1/2+i\gamma_j}} F(s, \chi) x^s \frac{ds}{s} \\ + O\left(1 + \frac{x \log x}{T} + \frac{(x + \max\{x, T\})^{1/2} + x^{1/2-c} T^{c+1} \exp \frac{A \log T}{\log \log T}}{T}\right). \end{aligned} \quad (3-16)$$

The implied constant and A depend only on χ and c .

Proof. By (3-3), Remark 3.4 and (3-14), it suffices to upper bound $\int_{J_j} |F(s, \chi)| |x^s| |ds|/|s|$ and $\int_{J_j} |F(s, \chi)| |x^s| |ds|/|s|$. We first treat I_j , and concentrate on I_2 as the argument for I_1 is analogous. We

have, using [Lemma 3.5](#),

$$\int_{I_2} |F(s, \chi)| |x^s| \frac{|ds|}{|s|} \ll \frac{1}{T} \int_{1/2-c}^{1+1/\log x} \sqrt{|L(\sigma + iT', \chi)L(\sigma + iT', \chi\chi_{-4})|} \sqrt[4]{\frac{|L(2\sigma + 2iT', \chi^2)|}{|L(2\sigma + 2iT', \chi^2\chi_{-4})|}} x^\sigma d\sigma \quad (3-17)$$

$$\ll \frac{1}{T} \int_{1/2-c}^{1+1/\log x} \sqrt{|L(\sigma + iT', \chi)L(\sigma + iT', \chi\chi_{-4})|} \sqrt[4]{\frac{|L(2\sigma + 2iT', \chi^2)|}{|L(2\sigma + 2iT', \chi^2\chi_{-4})|}} x^\sigma d\sigma. \quad (3-18)$$

It is now convenient to consider $\sigma \geq \frac{1}{2}$ and $\sigma \leq \frac{1}{2}$ separately.

If $\sigma \geq \frac{1}{2}$ we bound all the relevant L -functions using [Lemmas 3.6](#) and [3.7](#), obtaining that this part of the integral contributes

$$\ll \frac{\exp \frac{A \log T}{\log \log T}}{T} \int_{1/2}^{1+1/\log x} x^\sigma d\sigma \ll \frac{x \exp \frac{A \log T}{\log \log T}}{T}$$

where A is a constant large enough depending on χ . For σ below $\frac{1}{2}$ we first apply [Lemma 3.9](#) to the L -functions of χ and $\chi\chi_{-4}$ to reduce to the situation where the real parts of the variables inside the L -functions are $\geq \frac{1}{2}$. Then we apply [Lemmas 3.6](#) and [3.7](#) as before, obtaining that this part of the integral contributes

$$\ll \frac{\exp \frac{A \log T}{\log \log T}}{T} \int_{1/2-c}^{1/2} T^{1/2-\sigma} x^\sigma d\sigma \ll \frac{\max\{x, T\}^{1/2} \exp \frac{A \log T}{\log \log T}}{T}.$$

It follows that

$$\left(\int_{I_1} + \int_{I_2} \right) |F(s, \chi)| |x^s| \frac{|ds|}{|s|} \ll \frac{(x + \max\{x, T\}^{1/2}) \exp \frac{A \log T}{\log \log T}}{T}.$$

We turn to the contribution of J_j . We have

$$\sum_{j=1}^{m+1} \int_{J_j} |F(s, \chi)| |x^s| \frac{|ds|}{|s|} \ll x^{1/2-c} \int_{-T-1}^{T+1} |F(\frac{1}{2} - c + it, \chi)| \frac{dt}{|t| + 1} \quad (3-19)$$

$$\ll x^{1/2-c} \left(1 + \sum_{2^k \leq 2T} 2^{-k} \left(\int_{2^{k-1}}^{2^k} + \int_{-2^k}^{-2^{k-1}} \right) |F(\frac{1}{2} - c + it, \chi)| dt \right) \quad (3-20)$$

where

$$|F(\frac{1}{2} - c + it, \chi)| = \sqrt{|L(\frac{1}{2} - c + it, \chi)L(\frac{1}{2} - c + it, \chi\chi_{-4})|} \sqrt[4]{\frac{|L(1 - 2c + 2it, \chi^2)|}{|L(1 - 2c + 2it, \chi^2\chi_{-4})|}} \quad (3-21)$$

$$\ll (|t| + 4)^c \exp\left(A \frac{\log(|t| + 4)}{\log \log(|t| + 4)}\right) \ll T^c \exp\left(\frac{A \log T}{\log \log T}\right), \quad (3-22)$$

where we used Lemmas 3.6 and 3.9 to bound the L -functions of χ and $\chi\chi_{-4}$ and Lemma 3.8 for the other two L -functions. This leads to

$$\sum_{j=1}^{m+1} \int_{J_j} |F(s, \chi)| |x^s| \frac{|ds|}{|s|} \ll x^{1/2-c} T^c \exp\left(\frac{A \log T}{\log \log T}\right)$$

and concludes the proof. \square

4. Hankel calculus

In this section, \mathcal{H}_ρ is the Hankel contour described in (3-13), going around ρ in an anticlockwise fashion.

Lemma 4.1. *Let χ be a Dirichlet character. Assume GRH for $L(s, \chi)$. Given a nontrivial zero $\rho = \frac{1}{2} + i\gamma$ of $L(s, \chi)$ we have*

$$\max_{s \in \mathcal{H}_\rho} \left| \frac{L(s, \chi)}{s - \rho} \right| \ll (|\gamma| + 1)^{c+o(1)}.$$

Here the $o(1)$ exponent goes to 0 as γ goes to ∞ (and it might depend on χ), and the implied constant is absolute.

Proof. Since we can write $L(s, \chi)$ as $L(\rho, \chi)$ plus an integral of $L'(z, \chi)$ over a line segment connecting s and ρ , it follows that the maximum we try to bound is

$$\ll \max_{\substack{|s-\rho| \leq r, \text{ or} \\ s = \sigma + i\gamma \text{ with} \\ 1/2 - c \leq \sigma \leq 1/2}} |L'(s, \chi)|.$$

By Cauchy's integral formula, and Lemmas 3.6 and 3.9,

$$|L'(s, \chi)| \ll \int_{|z-s|=1/\log(|\gamma|+1)} \frac{|L(z, \chi)|}{|z-s|} |dz| \ll (|\gamma| + 1)^{\max\{0, 1/2 - \Re s\} + o(1)},$$

implying the desired bound. \square

Lemma 4.2. *Let χ be a nonprincipal Dirichlet character. Assume GRH for the characters in (3-15). Given a nontrivial zero $\rho = \frac{1}{2} + i\gamma \neq \frac{1}{2}$ of $L(s, \chi)L(s, \chi\chi_{-4})$ we have*

$$\int_{\mathcal{H}_\rho} |F(s, \chi)| |x^s| |ds| \ll \sqrt{x} (|\gamma| + 1)^{c+o(1)} ((\log x)^{-3/2} + r^{3/2} x^r).$$

Here the $o(1)$ exponent goes to 0 as γ goes to ∞ (and it might depend on χ), and the implied constant depends only on χ (it is independent of r).

Proof. We have, for s on the contour,

$$|F(s, \chi)| \ll \sqrt{|L(s, \chi)L(s, \chi\chi_{-4})|} (|\gamma| + 1)^{o(1)}$$

by Lemmas 3.5, 3.6 and 3.7. Integrating $\sqrt{|L(s, \chi)L(s, \chi\chi_{-4})|} |x^s|$ over the circle part of the contour contributes

$$\ll r x^{1/2+r} \int_{-\pi}^{\pi} \sqrt{|L(\rho + r e^{i\theta}, \chi)L(\rho + r e^{i\theta}, \chi\chi_{-4})|} d\theta.$$

Writing $L(s, \chi)L(s, \chi\chi_{-4})$ as $L(s, \chi)L(s, \chi\chi_{-4})/(s - \rho)$ times $s - \rho$ and appealing to Lemmas 4.1, 3.6 and 3.9, we find that this is

$$\ll r x^{1/2+r} (|\gamma| + 1)^{c+o(1)} \int_{-\pi}^{\pi} \sqrt{|r e^{i\theta}|} d\theta \ll r^{3/2} x^{1/2+r} (|\gamma| + 1)^{c+o(1)}.$$

Integrating $\sqrt{|L(s, \chi)L(s, \chi\chi_{-4})|} |x^s|$ over one of the segment parts of the contour contributes

$$\ll \sqrt{x} \int_{-c}^0 \sqrt{|L(\rho + t, \chi)L(\rho + t, \chi\chi_{-4})|} x^t dt.$$

Again writing $L(s, \chi)L(s, \chi\chi_{-4})$ as $L(s, \chi)L(s, \chi\chi_{-4})/(s - \rho)$ times $s - \rho$ and appealing to Lemma 4.1, we can bound this contribution by

$$\ll \sqrt{x} (|\gamma| + 1)^{c+o(1)} \int_{-\infty}^0 \sqrt{|t|} x^t dt \ll \sqrt{x} (|\gamma| + 1)^{c+o(1)} (\log x)^{-3/2}, \tag{4-1}$$

concluding the proof. □

Lemma 4.3. *Let χ be a nonprincipal Dirichlet character. Assume GRH for the characters in (3-15). For any pair $\rho_1 = \frac{1}{2} + i\gamma_1, \rho_2 = \frac{1}{2} + i\gamma_2$ of nontrivial zeros different from $\frac{1}{2}$ we have*

$$\frac{1}{X} \int_X^{2X} \int_{\mathcal{H}_{\rho_1}} \int_{\mathcal{H}_{\rho_2}} F(s_1, \chi) \overline{F(s_2, \chi)} \frac{x^{s_1}}{s_1} \frac{x^{\overline{s_2}}}{\overline{s_2}} ds_1 \overline{ds_2} dx \ll \frac{X((\log X)^{-3/2} + r^{3/2} X^r)^2}{((|\gamma_1| + 1)(|\gamma_2| + 1))^{1-c+o(1)} (1 + |\gamma_1 - \gamma_2|)} \tag{4-2}$$

where implied constants depend only on χ .

Proof. We first integrate by the x -variable and then take absolute values, obtaining that the integral is

$$\ll \int_{\mathcal{H}_{\rho_1}} \int_{\mathcal{H}_{\rho_2}} |F(s_1, \chi)| |F(s_2, \chi)| \frac{X^{\Re(s_1+s_2)}}{|s_1||s_2||s_1 + \overline{s_2} + 1|} |ds_1| |ds_2| \tag{4-3}$$

$$\ll \frac{1}{|\rho_1 \rho_2| (1 + |\gamma_1 - \gamma_2|)} \int_{\mathcal{H}_{\rho_1}} \int_{\mathcal{H}_{\rho_2}} |F(s_1, \chi)| |F(s_2, \chi)| X^{\Re(s_1+s_2)} |ds_1| |ds_2| \tag{4-4}$$

$$= \frac{1}{|\rho_1 \rho_2| (1 + |\gamma_1 - \gamma_2|)} \left(\int_{\mathcal{H}_{\rho_1}} |F(s_1, \chi)| X^{\Re(s_1)} |ds_1| \right) \left(\int_{\mathcal{H}_{\rho_2}} |F(s_2, \chi)| X^{\Re(s_2)} |ds_2| \right). \tag{4-5}$$

The result now follows from Lemma 4.2. □

Lemma 4.4. *Let χ be a nonprincipal Dirichlet character. Assume GRH for the characters in (3-15). If $\chi^2 \chi_{-4}$ is principal, or if χ^2 is principal as well as $L(\frac{1}{2}, \chi)L(\frac{1}{2}, \chi\chi_{-4}) = 0$ then*

$$\int_{\mathcal{H}_{1/2}} F(s, \chi) \frac{x^s}{s} ds \ll \sqrt{x} \left(x^r r^{5/4} + \frac{1}{(\log x)^{5/4}} \right).$$

The implied constant depends only on χ (it is independent of r).

Proof. This is a variation on [Lemma 4.2](#). If $\chi^2\chi_{-4}$ is principal we have

$$|F(s, \chi)| \ll \sqrt[4]{|2s - 1|}$$

on $\mathcal{H}_{1/2}$, where the implied constant depends only on χ . Similarly, if $L(\frac{1}{2}, \chi)L(\frac{1}{2}, \chi\chi_{-4}) = 0$ and χ^2 is principal then

$$|F(s, \chi)| \ll \sqrt{|s - \frac{1}{2}|} \sqrt[4]{\frac{1}{|2s - 1|}} \leq \sqrt[4]{|2s - 1|}$$

by [Lemma 4.1](#). In both cases the integral is

$$\ll \sqrt{x} \int_{\mathcal{H}_{1/2}} \sqrt[4]{|s - \frac{1}{2}|} x^{\max\{\Re s - 1/2, 0\}} |ds|.$$

The contribution of $\Re s \geq \frac{1}{2}$ is $\ll \sqrt{x} x^r r^{5/4}$, while the contribution of $\Re s \leq \frac{1}{2}$ is

$$\ll \sqrt{x} \int_{-\infty}^0 \sqrt[4]{|t|x^t} dt \ll \frac{\sqrt{x}}{(\log x)^{5/4}},$$

concluding the proof. □

Let C_q be the following positive constant, depending only on q :

$$C_q = \frac{2\pi^{-1/4}}{\Gamma(\frac{1}{4})} \prod_{p \equiv 3 \pmod{4}} \left(1 - \frac{1}{p^2}\right)^{-1/4} \prod_{\substack{p|q \\ p \equiv 3 \pmod{4}}} \left(1 - \frac{1}{p}\right)^{1/2}. \tag{4-6}$$

Lemma 4.5. *Let χ be a nonprincipal Dirichlet character modulo q . Assume GRH for the characters in (3-15). If χ^2 is principal and $L(\frac{1}{2}, \chi)L(\frac{1}{2}, \chi\chi_{-4}) \neq 0$ then*

$$\begin{aligned} \frac{1}{2\pi i} \int_{\mathcal{H}_{1/2}} F(s, \chi) \frac{x^s}{s} ds &= C_q \frac{\sqrt{x}}{(\log x)^{3/4}} \left(1 - \frac{\chi(2)}{\sqrt{2}}\right)^{-1/2} \sqrt{L(\frac{1}{2}, \chi)L(\frac{1}{2}, \chi\chi_{-4})} \left(1 + O\left(x^{-c/2}\right)\right) \\ &\quad + O\left(\sqrt{x} \left(x^r r^{7/4} + \frac{1}{(\log x)^{7/4}}\right)\right) \end{aligned} \tag{4-7}$$

where the implied constants depend only on χ .

Proof. Let $M(s, \chi) = \sqrt{L(s, \chi)L(s, \chi\chi_{-4})} \sqrt[4]{L(2s, \chi^2)(2s - 1)/L(2s, \chi^2\chi_{-4})} G(s, \chi)/s$ where G is defined in [Lemma 3.5](#). On $\mathcal{H}_{1/2}$ we have $F(s, \chi)/s = M(s, \chi)(2s - 1)^{-1/4}$. We define M at $s = \frac{1}{2}$ by its limit there, which exists as $L(s, \chi_0) = \zeta(s) \prod_{p|q} (1 - p^{-s})$ has a simple pole at $s = 1$. In fact, M is analytic in a neighborhood of $s = \frac{1}{2}$ by our assumption on χ and χ_{-4} . We have

$$M\left(\frac{1}{2}, \chi\right) = 2\sqrt{L\left(\frac{1}{2}, \chi\right)L\left(\frac{1}{2}, \chi\chi_{-4}\right)} \prod_{p|q} \left(1 - \frac{1}{p}\right)^{1/4} L(1, \chi_0\chi_{-4})^{-1/4} G\left(\frac{1}{2}, \chi\right).$$

The expression $L(1, \chi_0\chi_{-4})$ may be simplified as

$$L(1, \chi_{-4}) \prod_{p|q} (1 - \chi_{-4}(p)/p) = \prod_{p|q} (1 - \chi_{-4}(p)/p) \frac{\pi}{4}.$$

Our integral is

$$\frac{1}{2\pi i} \left(M\left(\frac{1}{2}, \chi\right) \int_{\mathcal{H}_{1/2}} (2s-1)^{-1/4} x^s ds + \int_{\mathcal{H}_{1/2}} (2s-1)^{-1/4} x^s (M(s, \chi) - M\left(\frac{1}{2}, \chi\right)) ds \right).$$

The second integral here is small, namely $\ll \sqrt{x}(x^r r^{7/4} + (\log x)^{-7/4})$, by an argument parallel to [Lemma 4.4](#). It suffices to show that

$$\frac{1}{2\pi i} \int_{\mathcal{H}_{1/2}} \left(s - \frac{1}{2}\right)^{-1/4} x^s ds = \frac{1}{\Gamma\left(\frac{1}{4}\right)} \frac{\sqrt{x}}{(\log x)^{3/4}} (1 + O(x^{-c/2})).$$

Making the change of variables $(s - \frac{1}{2}) \log x = y$, this boils down to Hankel’s Γ -function representation; see, e.g., [\[Tenenbaum 2015, Corollary II.0.18\]](#). □

5. Proof of [Theorem 1.1](#)

5A. Character sum estimates.

Proposition 5.1. *Let χ be a nonprincipal Dirichlet character modulo q . Assume GRH for the characters in (3-15). If $\chi^2 \neq \chi_0$ we have*

$$\frac{1}{X} \int_X^{2X} \left| \sum_{\substack{n \leq x \\ n \in S}} \chi(n) \right|^2 dx \ll \frac{X}{(\log X)^3},$$

while if $\chi^2 = \chi_0$ we have

$$\frac{1}{X} \int_X^{2X} \left| \sum_{\substack{n \leq x \\ n \in S}} \chi(n) - C_q \frac{\sqrt{x}}{(\log x)^{3/4}} \left(1 - \frac{\chi(2)}{\sqrt{2}}\right)^{-1/2} \sqrt{L\left(\frac{1}{2}, \chi\right)L\left(\frac{1}{2}, \chi\chi_{-4}\right)} \right|^2 dx \ll \frac{X}{(\log X)^{5/2}},$$

where C_q is defined in (4-6). The implied constants depend only on q .

Proof. By [Lemma 3.10](#) with $T = X^{3/4} \asymp x^{3/4}$ and $c = \frac{1}{10}$ we have, uniformly for $x \in [X, 2X]$,

$$\sum_{\substack{n \leq x \\ n \in S}} \chi(n) = \sum_{j=1}^m \frac{1}{2\pi i} \int_{\mathcal{H}_{1/2+i\gamma_j}} F(s, \chi) x^s \frac{ds}{s} + O(x^{1/2-1/100})$$

for any nonprincipal χ . The function F is defined in the first line of [Section 3](#) and is analytic in the set (3-7) or in the set (3-8), depending on χ . The $m = m_\chi$ contours $\mathcal{H}_{1/2+i\gamma_j} = \mathcal{H}_{1/2+i\gamma_j, \chi}$ are defined in [Section 3D](#). They are Hankel loop contours going anticlockwise around zeros $\frac{1}{2} + i\gamma_j$ of $L(s, \chi)L(s, \chi\chi_{-4})$ up to height T (exclusive), as well as around $s = \frac{1}{2}$ in case χ^2 or $\chi^2\chi_{-4}$ is principal. Let us write

$$\sum_{\substack{n \leq x \\ n \in S}} \chi(n) = S_1(x) + S_2(x) + O(x^{1/2-1/100})$$

where $S_1(x)$ is the contribution of Hankel loops not going around $\frac{1}{2}$:

$$S_1(x) = \sum_{\substack{1 \leq j \leq m \\ \gamma_j \neq 0}} \frac{1}{2\pi i} \int_{\mathcal{H}_{1/2+i\gamma_j}} F(s, \chi) x^s \frac{ds}{s},$$

and S_2 is the contribution of the loop around $s = \frac{1}{2}$, in case such a loop exists:

$$S_2(x) = \begin{cases} \frac{1}{2\pi i} \int_{\mathcal{H}_{1/2}} F(s, \chi) x^s \frac{ds}{s} & \text{if } L\left(\frac{1}{2}, \chi\right)L\left(\frac{1}{2}, \chi\chi_{-4}\right) = 0 \text{ or } \chi_0 \in \{\chi^2\chi_{-4}, \chi^2\}, \\ 0 & \text{otherwise.} \end{cases}$$

We shall take $r = o(1/\log X)$ in all the definitions of the loops. If $L\left(\frac{1}{2}, \chi\right)L\left(\frac{1}{2}, \chi\chi_{-4}\right) = 0$ or $\chi^2\chi_{-4} = \chi_0$ we have, by [Lemma 4.4](#), the pointwise bound

$$S_2(x) \ll \frac{\sqrt{x}}{(\log x)^{5/4}}.$$

If $\chi^2 = \chi_0$ and $L\left(\frac{1}{2}, \chi\right)L\left(\frac{1}{2}, \chi\chi_{-4}\right) \neq 0$, we have by [Lemma 4.5](#) the following asymptotic relation:

$$S_2(x) = C_q \frac{\sqrt{x}}{(\log x)^{3/4}} \left(1 - \frac{\chi(2)}{\sqrt{2}}\right)^{-1/2} \sqrt{L\left(\frac{1}{2}, \chi\right)L\left(\frac{1}{2}, \chi\chi_{-4}\right)} + O\left(\frac{\sqrt{x}}{(\log x)^{7/4}}\right).$$

In all cases,

$$S_2(x) = \mathbf{1}_{\chi^2 = \chi_0} C_q \frac{\sqrt{x}}{(\log x)^{3/4}} \left(1 - \frac{\chi(2)}{\sqrt{2}}\right)^{-1/2} \sqrt{L\left(\frac{1}{2}, \chi\right)L\left(\frac{1}{2}, \chi\chi_{-4}\right)} + O\left(\frac{\sqrt{x}}{(\log x)^{5/4}}\right).$$

It now suffices to show that $(1/X) \int_X^{2X} |S_1(x)|^2 dx \ll X/(\log X)^3$. We have, by [Lemma 4.3](#),

$$\frac{1}{X} \int_X^{2X} |S_1(x)|^2 dx \ll \frac{1}{X} \int_X^{2X} \left| \sum_{\substack{1 \leq j \leq m \\ \gamma_j \neq 0}} \int_{\mathcal{H}_{1/2+i\gamma_j}} F(s, \chi) x^s \frac{ds}{s} \right|^2 \tag{5-1}$$

$$\ll \frac{X}{(\log X)^3} \sum_{\substack{\gamma_1, \gamma_2 \neq 0: \\ L(1/2+i\gamma_j, \chi) = 0 \text{ or} \\ L(1/2+i\gamma_j, \chi\chi_{-4}) = 0}} \frac{1}{|\gamma_1\gamma_2|^{1-1/5} (1 + |\gamma_1 - \gamma_2|)}. \tag{5-2}$$

The sum over zeros converges by a standard argument; see [\[Montgomery and Vaughan 2007, Theorem 13.5\]](#) where this is proved in the case of zeros of the Riemann zeta function. The only input needed is that between height T and $T + 1$ there are $\ll \log T$ zeros, which is true for any Dirichlet L -function; see [\[loc. cit., Theorem 10.17\]](#). □

5B. Conclusion of proof. Suppose a, b satisfy $a \equiv b \equiv 1 \pmod{4, q}$ and $(a, q) = (b, q) = 1$. Suppose the constant $C_{q,a,b}$ appearing in (1-3) is positive. Consider $X \gg 1$ which will tend to ∞ . By orthogonality of characters we write

$$S(x; q, a) - S(x; q, b) = \frac{1}{\phi(q)} \sum_{\chi_0 \neq \chi \pmod q} \overline{(\chi(a) - \chi(b))} \sum_{\substack{n \leq x \\ n \in S}} \chi(n) \tag{5-3}$$

for each $x \in [X, 2X]$. By [Proposition 5.1](#) and Cauchy–Schwarz, we can write

$$S(x; q, a) - S(x; q, b) = \frac{C_q}{\phi(q)} \frac{\sqrt{x}}{(\log x)^{3/4}} C_{q,a,b} + T(x) \tag{5-4}$$

where

$$\frac{1}{X} \int_X^{2X} |T(x)|^2 dx \ll \frac{X}{(\log X)^{5/2}}.$$

We see that in an L^2 -sense, $T(x)$ is smaller (by a power of $\log x$) than the term of order $\sqrt{x}/(\log x)^{3/4}$ in [\(5-4\)](#). To make this precise, we use Chebyshev’s inequality:

$$\mathbb{P}_{x \in [X, 2X]} \left(|T(x)| \geq \frac{\sqrt{X}}{\Psi(X)(\log X)^{3/4}} \right) \ll \frac{\Psi^2(X)}{\log X} = o(1)$$

for any function Ψ tending to ∞ slower than $(\log X)^{1/2}$. Here x is a number chosen uniformly at random between X and $2X$. It follows that $\mathbb{P}_{x \in [X, 2X]}(S(x; q, a) > S(x; q, b)) \sim 1$ which finishes the proof. \square

6. Martin’s conjecture

6A. Preparation. Let $F_\omega(s, \chi) = \sum_{n \geq 1} \chi(n)\omega(n)/n^s$ for $\Re s > 1$. By [Lemma 3.1](#) with $\kappa = 1 + 1/\log x$ and $\omega(n) \ll \log n$,

$$\sum_{n \leq x} \chi(n)\omega(n) = \frac{1}{2\pi i} \int_{1+1/\log x - iT}^{1+1/\log x + iT} F_\omega(s, \chi) x^s \frac{ds}{s} + O\left(\log x + \frac{x \log^2 x}{T}\right) \tag{6-1}$$

for all $T \gg 1$. We have $\omega = 1 * \mathbf{1}_{\text{primes}}$. For $\Re s > 1$ this identity leads to

$$F_\omega(s, \chi) = L(s, \chi) \left(\log L(s, \chi) - \frac{1}{2} \log L(2s, \chi^2) + G_\omega(s, \chi) \right) \tag{6-2}$$

where G_ω may be analytically continued to $\Re s > \frac{1}{3}$, and is bounded in $\Re s \geq \frac{1}{3} + \varepsilon$; see [\[Meng 2020, \(2.3\)\]](#). If χ is nonprincipal, GRH for χ and χ^2 implies that F_ω can be analytically continued to

$$\left\{ s \in \mathbb{C} : \Re s > \frac{1}{3} \right\} \setminus \left\{ \sigma + it : L\left(\frac{1}{2} + it, \chi\right) = 0 \text{ and } \sigma \leq \frac{1}{2} \right\} \tag{6-3}$$

if χ^2 is nonprincipal, and

$$\left\{ s \in \mathbb{C} : \Re s > \frac{1}{3} \right\} \setminus \left(\left\{ \sigma + it : L\left(\frac{1}{2} + it, \chi\right) = 0 \text{ and } \sigma \leq \frac{1}{2} \right\} \cup \left\{ \sigma : \sigma \leq \frac{1}{2} \right\} \right) \tag{6-4}$$

if χ^2 is principal. Almost the same analysis applies for $F_\Omega(s, \chi) = \sum_{n \geq 1} \chi(n)\Omega(n)/n^s$, with the only change being the following variation on [\(6-2\)](#):

$$F_\Omega(s, \chi) = L(s, \chi) \left(\log L(s, \chi) + \frac{1}{2} \log L(2s, \chi^2) + G_\Omega(s, \chi) \right)$$

where G_Ω may be analytically continued to $\Re s > \frac{1}{3}$ and is bounded in $\Re s \geq \frac{1}{3} + \varepsilon$. This is a consequence of $\Omega = 1 * \mathbf{1}_{\text{prime powers}}$. The following lemma is essentially [\[Meng 2020, Lemma 3\]](#), and its proof is similar to the proof of [Lemma 3.10](#).

Lemma 6.1. *Let χ be a nonprincipal character. Assume GRH holds for χ and χ^2 . Let $c \in (0, \frac{1}{6})$ be a fixed constant. Let $T \gg 1$. We have*

$$\sum_{n \leq x} \chi(n)\omega(n) = \sum_{j=1}^m \frac{1}{2\pi i} \int_{\mathcal{H}_{1/2+i\gamma_j}} F_\omega(s, \chi)x^s \frac{ds}{s} + O\left(\log x + \frac{x \log^2 x}{T} + \frac{(x + \max\{x, T\})^{1/2} + x^{1/2-c} T^{c+1}}{T} \exp \frac{A \log T}{\log \log T}\right) \tag{6-5}$$

where the list $\{\frac{1}{2} + i\gamma_j\}_{j=1}^m$ consists of the distinct nontrivial zeros of $L(s, \chi)$ with $-T'' \leq t \leq T'$ where T', T'' depend only on T and χ are satisfy $T', T'' = T + O(1)$. If χ^2 is principal we include $\frac{1}{2}$ in the list.

Here \mathcal{H}_ρ is the truncated Hankel loop contour defined in (3-13), and it has radius r which is chosen to be sufficiently small (in terms of T, x and the list of γ_j s). The implied constant and A depend only on χ and c .

Proof. The proof is similar to that of Lemma 3.10, the main difference being the appearance of the factor $\log L(s, \chi)$ because of (6-2). We need to be careful because $\log L(s, \chi)$ may be large even if $L(s, \chi)$ is small. We need to explain why the contribution of $\log L(s, \chi)$ may be absorbed into $\exp(A \log T / \log \log T)$. We shall show that $\log L(s, \chi) = O(\log T)$ holds on the relevant contour. Recall that $\arg L(s, \chi)$ is defined via $\log L(s, \chi) = \log|L(s, \chi)| + i \arg L(s, \chi)$. We have $\arg L(s, \chi) = O(\log(|t| + 4))$ uniformly in t and $\sigma \in [\frac{1}{6}, 2]$; see [Montgomery and Vaughan 2007, Lemma 12.8]. Hence our focus will be on bounding $\log|L(s, \chi)|$. By Lemmas 3.6 and 3.9 we have $\log|L(\sigma + it, \chi)| \leq C \log(|t| + 4)$ for $|t| \gg 1$ and $\sigma \in [\frac{1}{6}, 2]$, so that we have an easy upper bound on $\log|L(s, \chi)|$, and the focus is truly on lower bounding $\log|L(s, \chi)|$.

We want to shift the contour in (6-1) to $\Re s = \frac{1}{2} - c$ and avoid logarithmic singularities using Hankel loops. Before we do so, we replace the endpoints of the integral, namely $1 + 1/\log x \pm iT$, with $1 + 1/\log x + iT'$ and $1 + 1/\log x - iT''$, where $T', T'' = T + O(1)$ and the bound $\log|L(s, \chi)| \geq -C \log(|t| + 4)$ holds uniformly on $\Im s = T'$ and $\Im s = -T''$ with $\sigma \in [\frac{1}{6}, 2]$. Changing the endpoints does not affect the error term in (6-1) due to a simple variation on Remark 3.4. The existence of such T' and T'' is exactly the content of [Montgomery and Vaughan 2007, Theorem 13.22].

Lemmas 3.6–3.9 allow us to bound both the vertical and horizontal contributions of $L(s, \chi)$ and $\log L(2s, \chi^2)$. The horizontal contribution of $\log L(s, \chi)$ is small due to the choice of T' and T'' . To bound the vertical contribution of $\log L(s, \chi)$ we use [Montgomery and Vaughan 2007, Example 1 in Section 12.1.1] which says that for $\Re s \geq \frac{1}{6}$,

$$\log L(s, \chi) = \sum_{\rho: |\gamma-t| \leq 1} \log(s - \rho) + O(\log(|t| + 4))$$

unconditionally. Applying this with $\rho = \frac{1}{2} - c + it$ this is $O_c(\log|t|)$ since all the zeros satisfying $|\gamma - t| \leq 1$ are nontrivial and lie on $\Re s = \frac{1}{2}$, and there are $\ll \log|t|$ zeros between height $t - 1$ and $t + 1$. □

The following lemma is implicit in [Meng 2020, pages 110–111].

Lemma 6.2. *Let χ be a nonprincipal character and suppose GRH holds for χ and χ^2 . Let $\rho = \frac{1}{2} + i\gamma \neq \frac{1}{2}$ be a nontrivial zero of $L(s, \chi)$. Let $m_{\rho, \chi}$ be the multiplicity of ρ in $L(s, \chi)$. We have*

$$\int_{\mathcal{H}_\rho} F_\omega(s, \chi)x^s \frac{ds}{s} = m_{\rho, \chi} \int_{\mathcal{H}_\rho} L(s, \chi) \log(s - \rho)x^s \frac{ds}{s}.$$

Proof. Since

$$F_\omega(s, \chi) = L(s, \chi) \log L(s, \chi) - \frac{1}{2}L(s, \chi) \log L(2s, \chi^2) + L(s, \chi)G_\omega(s, \chi)$$

and $L(s, \chi) \log L(2s, \chi^2)$, $L(s, \chi)G_\omega(s, \chi)$ are analytic in an open set containing \mathcal{H}_ρ , it follows that

$$\int_{\mathcal{H}_\rho} F_\omega(s, \chi)x^s \frac{ds}{s} = \int_{\mathcal{H}_\rho} L(s, \chi) \log L(s, \chi)x^s \frac{ds}{s}$$

by Cauchy’s integral theorem. We may write $\log L(s, \chi)$ as

$$\log L(s, \chi) = m_{\rho, \chi} \log(s - \rho) + H_\rho(s, \chi)$$

for a function H_ρ which is analytic in an open set containing the loop, since $L(s, \chi)/(s - \rho)^{m_{\rho, \chi}}$ has a removable singularity at $s = \rho$.³ By Cauchy’s integral theorem, $H_\rho(s, \chi)$ does not contribute to the Hankel contour integral, giving the conclusion. □

Lemmas 6.1 and 6.2 hold as stated for Ω in place of ω as well. We have the following lemma, a “logarithmic” analogue of Lemma 4.2.

Lemma 6.3. *Let χ be a nonprincipal character and suppose GRH holds for χ . Let $\rho = \frac{1}{2} + i\gamma$ be a nontrivial zero of $L(s, \chi)$. Let*

$$I_\rho := \int_{H_\rho} |L(s, \chi)| |\log(s - \rho)| x^{\Re s} |ds|.$$

Then

$$I_\rho \ll \sqrt{x} (|\gamma| + 1)^{c+o(1)} \left(\frac{\log \log x}{\log^2 x} + \log(r^{-1})r^2x^r \right).$$

Proof. We write $L(s, \chi)$ as $L(s, \chi)/(s - \rho)$ times $(s - \rho)$, and use Lemma 4.1 to bound $L(s, \chi)/(s - \rho)$ by $(|\gamma| + 1)^{c+o(1)}$. We now consider separately $|s - \rho| = r$ and $s = \rho + t$, $-c \leq t \leq -r$. □

The following is an ω -analogue of Lemmas 4.4 and 4.5.

Lemma 6.4. *Let χ be a nonprincipal Dirichlet character. Assume GRH holds for χ and χ^2 :*

(1) *If $L(\frac{1}{2}, \chi) = 0$ then*

$$\int_{\mathcal{H}_{1/2}} F_\omega(s, \chi) \frac{x^s}{s} ds \ll \sqrt{x} \left(\frac{\log \log x}{\log^2 x} + \log(r^{-1})r^2x^r \right).$$

³An estimate for $H_\rho(s, \chi)$ on \mathcal{H}_ρ may be obtained; see [Meng 2020, (2.15)].

(2) If χ^2 is principal and $L(\frac{1}{2}, \chi) \neq 0$ then

$$\frac{1}{2\pi i} \int_{\mathcal{H}_{1/2}} F_\omega(s, \chi) \frac{x^s}{s} ds = -L(\frac{1}{2}, \chi) \frac{\sqrt{x}}{\log x} + O\left(\frac{\sqrt{x}}{(\log x)^2}\right). \tag{6-6}$$

The implied constants depend only on χ .

Proof. The first part is a minor modification of the proof of Lemma 6.3. The second part is [Meng 2020, (2.28)]. □

Lemma 6.4 holds for Ω in place of ω , with the only difference being a sign change in (6-6).

6B. Proof of Theorem 2.1. We shall prove the theorem in the case of ω ; the proof for Ω is analogous. Suppose a, b satisfy $(a, q) = (b, q) = 1$. Suppose the constant $D_{q,a,b}$ appearing in (2-11) is positive. Consider $X \gg 1$ which will tend to ∞ . By orthogonality of characters we write

$$\sum_{\substack{n \leq x \\ n \equiv a \pmod q}} \omega(n) - \sum_{\substack{n \leq x \\ n \equiv b \pmod q}} \omega(n) = \frac{1}{\phi(q)} \sum_{\chi_0 \neq \chi \pmod q} \overline{(\chi(a) - \chi(b))} \sum_{n \leq x} \chi(n) \omega(n) \tag{6-7}$$

for each $x \in [X, 2X]$. By (6-5) with $T = X^{3/4} \asymp x^{3/4}$ and $c = \frac{1}{10}$ we have, uniformly for $x \in [X, 2X]$,

$$\sum_{n \leq x} \chi(n) \omega(n) = \sum_{j=1}^m \frac{1}{2\pi i} \int_{\mathcal{H}_{1/2+i\gamma_j}} F_\omega(s, \chi) x^s \frac{ds}{s} + O(x^{1/2-1/100})$$

for any nonprincipal χ . For any pair $\rho_1 = \frac{1}{2} + i\gamma_1, \rho_2 = \frac{1}{2} + i\gamma_2$ of nontrivial zeros of $L(s, \chi)$ different from $\frac{1}{2}$ we have, from Lemmas 6.2 and 6.3,

$$\begin{aligned} \frac{1}{X} \int_X^{2X} \int_{\mathcal{H}_{\rho_1}} F_\omega(s_1, \chi) x^{s_1} \frac{ds_1}{s_1} \overline{\int_{\mathcal{H}_{\rho_2}} F_\omega(s_2, \chi) x^{s_2} \frac{ds_2}{s_2}} \\ \ll \frac{m_{\rho_1, \chi} m_{\rho_2, \chi}}{|\gamma_1 \gamma_2|^{1-c+o(1)} (1 + |\gamma_1 - \gamma_2|)} X \left(\frac{\log \log X}{\log^2 X} + \log r^{-1} r^2 x^r \right)^2 \end{aligned} \tag{6-8}$$

in analogy with Lemma 4.3. We take $r = o(1/\log X)$. Since $m_\rho = O(\log(|\rho| + 1))$ [Montgomery and Vaughan 2007, Theorem 10.17] and

$$\sum_{\substack{\gamma_1, \gamma_2 \neq 0: \\ L(1/2+i\gamma_j, \chi) = 0}} \frac{1}{|\gamma_1 \gamma_2|^{1-1/5} (1 + |\gamma_1 - \gamma_2|)}$$

converges [Montgomery and Vaughan 2007, Theorem 13.5], it follows that in an L^2 -sense, the contribution of $\rho \neq \frac{1}{2}$ to (6-7) is $O(\sqrt{x} \log \log x / (\log x)^2)$; this step corresponds to (5-1). By Lemma 6.4, the contribution of loops around $s = \frac{1}{2}$ is

$$-\frac{\sqrt{x}}{\log x} \frac{1}{\phi(q)} \sum_{\substack{\chi \pmod q \\ \chi^2 = \chi_0}} \overline{\chi(a) - \chi(b)} L(\frac{1}{2}, \chi) + O\left(\frac{\sqrt{x} \log \log x}{\log^2 x}\right) = -\frac{\sqrt{x}}{\log x} \left(\frac{D_{q,a,b}}{\phi(q)} + o(1) \right).$$

As in the proof of [Theorem 1.1](#), Chebyshev’s inequality allows us to conclude the following. The probability that for a number x chosen uniformly at random from $[X, 2X]$, $\sum_{n \leq x, n \equiv a \pmod q} \omega(n) < \sum_{n \leq x, n \equiv b \pmod q} \omega(n)$ tends to 1 with X . This finishes the proof. \square

Acknowledgements

We thank James Maynard and Zeev Rudnick for helpful discussions, Dor Elboim for teaching me about the Hankel contour, Dan Carmon and Max Xu for typographical corrections, Tom Bloom for pointing out the works of Kaczorowski and Andrew Granville for useful comments that substantially improved the presentation. We are thankful for the referee’s thorough reading of the manuscript and valuable comments. This project has received funding from the European Research Council (ERC) under the European Union’s Horizon 2020 research and innovation programme (grant agreement No 851318).

References

- [Bailleul 2021] A. Bailleul, “Chebyshev’s bias in dihedral and generalized quaternion Galois groups”, *Algebra Number Theory* **15**:4 (2021), 999–1041. [MR](#) [Zbl](#)
- [Best and Trudgian 2015] D. G. Best and T. S. Trudgian, “Linear relations of zeroes of the zeta-function”, *Math. Comp.* **84**:294 (2015), 2047–2058. [MR](#) [Zbl](#)
- [Cha 2008] B. Cha, “Chebyshev’s bias in function fields”, *Compos. Math.* **144**:6 (2008), 1351–1374. [MR](#) [Zbl](#)
- [Cha et al. 2016] B. Cha, D. Fiorilli, and F. Jouve, “Prime number races for elliptic curves over function fields”, *Ann. Sci. Éc. Norm. Supér. (4)* **49**:5 (2016), 1239–1277. [MR](#) [Zbl](#)
- [Chebyshev 1853] P. L. Chebyshev, “Lettre de M. le professeur Tchébychev à M. Fuss [Mr. P. N. Fuss, Permanent Secretary of the Academy], sur un nouveau théorème relatif aux nombres premiers contenus dans les formes $4n + 1$ et $4n + 3$ ”, *Bull. phys. math. Acad. St. Petersb.* **11**:13 (1853), p. 208. Reprinted as pp. 697–698 in *Oeuvres de P. L. Tchebychef*, vol. I, edited by A. A. Markoff and N. Y. Sonin, Académie impériale des sciences, St. Petersburg, 1899.
- [Chowla 1965] S. Chowla, *The Riemann hypothesis and Hilbert’s tenth problem*, Mathematics and its Applications **4**, Gordon and Breach Science Publishers, New York, 1965. [MR](#) [Zbl](#)
- [Conrey and Soundararajan 2002] J. B. Conrey and K. Soundararajan, “Real zeros of quadratic Dirichlet L -functions”, *Invent. Math.* **150**:1 (2002), 1–44. [MR](#) [Zbl](#)
- [David et al. 2022] C. David, L. Devin, J. Nam, and J. Schlitt, “Lemke Oliver and Soundararajan bias for consecutive sums of two squares”, *Math. Ann.* **384**:3-4 (2022), 1181–1242. [MR](#) [Zbl](#)
- [Devin 2020] L. Devin, “Chebyshev’s bias for analytic L -functions”, *Math. Proc. Cambridge Philos. Soc.* **169**:1 (2020), 103–140. [MR](#) [Zbl](#)
- [Devin 2021] L. Devin, “Discrepancies in the distribution of Gaussian primes”, preprint, 2021. [arXiv 2105.02492](#)
- [Devin and Meng 2021] L. Devin and X. Meng, “Chebyshev’s bias for products of irreducible polynomials”, *Adv. Math.* **392** (2021), Paper No. 108040, 45. [MR](#) [Zbl](#)
- [Dummit et al. 2016] D. Dummit, A. Granville, and H. Kisilevsky, “Big biases amongst products of two primes”, *Mathematika* **62**:2 (2016), 502–507. [MR](#) [Zbl](#)
- [Fiorilli 2014a] D. Fiorilli, “Elliptic curves of unbounded rank and Chebyshev’s bias”, *Int. Math. Res. Not.* **2014**:18 (2014), 4997–5024. [MR](#) [Zbl](#)
- [Fiorilli 2014b] D. Fiorilli, “Highly biased prime number races”, *Algebra Number Theory* **8**:7 (2014), 1733–1767. [MR](#) [Zbl](#)
- [Fiorilli and Jouve 2022] D. Fiorilli and F. Jouve, “Unconditional Chebyshev biases in number fields”, *J. Éc. polytech. Math.* **9** (2022), 671–679. [MR](#) [Zbl](#)

- [Flajolet and Vardi 1996] P. Flajolet and I. Vardi, “Zeta function expansions of classical constants”, preprint, 1996, available at <https://algo.inria.fr/flajolet/Publications/FIVa96.pdf>.
- [Ford and Sneed 2010] K. Ford and J. Sneed, “Chebyshev’s bias for products of two primes”, *Experiment. Math.* **19**:4 (2010), 385–398. [MR](#) [Zbl](#)
- [Gorodetsky and Rodgers 2021] O. Gorodetsky and B. Rodgers, “The variance of the number of sums of two squares in $\mathbb{F}_q[T]$ in short intervals”, *Amer. J. Math.* **143**:6 (2021), 1703–1745. [MR](#) [Zbl](#)
- [Hardy 1940] G. H. Hardy, *Ramanujan, twelve lectures on subjects suggested by his life and work*, Cambridge University Press, 1940. [MR](#) [Zbl](#)
- [Iwaniec 1976] H. Iwaniec, “The half dimensional sieve”, *Acta Arith.* **29**:1 (1976), 69–95. [MR](#) [Zbl](#)
- [Kaczorowski 1992] J. Kaczorowski, “The boundary values of generalized Dirichlet series and a problem of Chebyshev”, pp. 14, 227–235 in *Journées de Géométrie Algébrique d’Orsay* (Geneva, 1991), Astérisque **209**, Société Mathématique de France, Paris, 1992. [MR](#) [Zbl](#)
- [Kaczorowski 1995] J. Kaczorowski, “On the distribution of primes (mod 4)”, *Analysis* **15**:2 (1995), 159–171. [MR](#) [Zbl](#)
- [Knapowski and Turán 1962] S. Knapowski and P. Turán, “Comparative prime-number theory, I: Introduction”, *Acta Math. Acad. Sci. Hungar.* **13** (1962), 299–314. [MR](#) [Zbl](#)
- [Landau 1908] E. Landau, “Über die Einteilung der positiven ganzen Zahlen in vier Klassen nach der Mindestzahl der zu ihrer additiven Zusammensetzung erforderlichen Quadrate”, *Arch. Math. Phys.* **3**:13 (1908), 305–312.
- [Littlewood 1914] J. E. Littlewood, “Sur la distribution des nombres premiers”, *C. R. Acad. Sci., Paris* **158** (1914), 1869–1872. [Zbl](#)
- [Meng 2018] X. Meng, “Chebyshev’s bias for products of k primes”, *Algebra Number Theory* **12**:2 (2018), 305–341. [MR](#) [Zbl](#)
- [Meng 2020] X. Meng, “Number of prime factors over arithmetic progressions”, *Q. J. Math.* **71**:1 (2020), 97–121. [MR](#) [Zbl](#)
- [Montgomery and Vaughan 2007] H. L. Montgomery and R. C. Vaughan, *Multiplicative number theory, I: Classical theory*, Cambridge Studies in Advanced Mathematics **97**, Cambridge University Press, 2007. [MR](#) [Zbl](#)
- [Moree 2004] P. Moree, “Chebyshev’s bias for composite numbers with restricted prime divisors”, *Math. Comp.* **73**:245 (2004), 425–449. [MR](#) [Zbl](#)
- [Ng 2000] N. C. Ng, *Limiting distributions and zeros of Artin L -functions*, Ph.D. thesis, University of British Columbia, 2000.
- [Porritt 2020] S. Porritt, “Character sums over products of prime polynomials”, preprint, 2020. [arXiv 2003.12002](https://arxiv.org/abs/2003.12002)
- [Prachar 1953] K. Prachar, “Über Zahlen der Form $a^2 + b^2$ in einer arithmetischen Progression”, *Math. Nachr.* **10** (1953), 51–54. [MR](#) [Zbl](#)
- [Radziejewski 2014] M. Radziejewski, “Oscillatory properties of real functions with weakly bounded Mellin transform”, *Q. J. Math.* **65**:1 (2014), 249–266. [MR](#) [Zbl](#)
- [Ramachandra 1976] K. Ramachandra, “Some problems of analytic number theory”, *Acta Arith.* **31**:4 (1976), 313–324. [MR](#)
- [Riemann 2013] B. Riemann, “Ueber die Anzahl der Primzahlen unter einer gegebenen Grösse”, pp. 136–144 in *Bernard Riemann’s gesammelte mathematische Werke und wissenschaftlicher Nachlass*, edited by R. Dedekind and H. M. Weber, Cambridge University Press, 2013.
- [Rubinstein and Sarnak 1994] M. Rubinstein and P. Sarnak, “Chebyshev’s bias”, *Experiment. Math.* **3**:3 (1994), 173–197. [MR](#) [Zbl](#)
- [Rumely 1993] R. Rumely, “Numerical computations concerning the ERH”, *Math. Comp.* **61**:203 (1993), 415–440, S17–S23. [MR](#) [Zbl](#)
- [Shanks 1964] D. Shanks, “The second-order term in the asymptotic expansion of $B(x)$ ”, *Math. Comp.* **18** (1964), 75–86. [MR](#) [Zbl](#)
- [Soundararajan 2000] K. Soundararajan, “Nonvanishing of quadratic Dirichlet L -functions at $s = \frac{1}{2}$ ”, *Ann. of Math. (2)* **152**:2 (2000), 447–488. [MR](#) [Zbl](#)
- [Tenenbaum 2015] G. Tenenbaum, *Introduction to analytic and probabilistic number theory*, 3rd ed., Graduate Studies in Mathematics **163**, American Mathematical Society, Providence, RI, 2015. [MR](#) [Zbl](#)

Communicated by Andrew Granville

Received 2021-11-30 Revised 2022-05-01 Accepted 2022-06-21

ofir.goro@gmail.com

Mathematical Institute, University of Oxford, Oxford, United Kingdom

Guidelines for Authors

Authors may submit manuscripts in PDF format on-line at the Submission page at the [ANT website](#).

Originality. Submission of a manuscript acknowledges that the manuscript is original and is not, in whole or in part, published or under consideration for publication elsewhere. It is understood also that the manuscript will not be submitted elsewhere while under consideration for publication in this journal.

Language. Articles in *ANT* are usually in English, but articles written in other languages are welcome.

Length There is no a priori limit on the length of an *ANT* article, but *ANT* considers long articles only if the significance-to-length ratio is appropriate. Very long manuscripts might be more suitable elsewhere as a memoir instead of a journal article.

Required items. A brief abstract of about 150 words or less must be included. It should be self-contained and not make any reference to the bibliography. If the article is not in English, two versions of the abstract must be included, one in the language of the article and one in English. Also required are keywords and subject classifications for the article, and, for each author, postal address, affiliation (if appropriate), and email address.

Format. Authors are encouraged to use L^AT_EX but submissions in other varieties of T_EX, and exceptionally in other formats, are acceptable. Initial uploads should be in PDF format; after the refereeing process we will ask you to submit all source material.

References. Bibliographical references should be complete, including article titles and page ranges. All references in the bibliography should be cited in the text. The use of BibT_EX is preferred but not required. Tags will be converted to the house format, however, for submission you may use the format of your choice. Links will be provided to all literature with known web locations and authors are encouraged to provide their own links in addition to those supplied in the editorial process.

Figures. Figures must be of publication quality. After acceptance, you will need to submit the original source files in vector graphics format for all diagrams in your manuscript: vector EPS or vector PDF files are the most useful.

Most drawing and graphing packages (Mathematica, Adobe Illustrator, Corel Draw, MATLAB, etc.) allow the user to save files in one of these formats. Make sure that what you are saving is vector graphics and not a bitmap. If you need help, please write to graphics@msp.org with details about how your graphics were generated.

White space. Forced line breaks or page breaks should not be inserted in the document. There is no point in your trying to optimize line and page breaks in the original manuscript. The manuscript will be reformatted to use the journal's preferred fonts and layout.

Proofs. Page proofs will be made available to authors (or to the designated corresponding author) at a Web site in PDF format. Failure to acknowledge the receipt of proofs or to return corrections within the requested deadline may cause publication to be postponed.

Algebra & Number Theory

Volume 17 No. 3 2023

Quadratic relations between Bessel moments	541
JAVIER FRESÁN, CLAUDE SABBAB and JENG-DAW YU	
Morphismes de périodes et cohomologie syntomique	603
SALLY GILLES	
Maximizing Sudler products via Ostrowski expansions and cotangent sums	667
CHRISTOPH AISTLEITNER and BENCE BORDA	
Free rational curves on low degree hypersurfaces and the circle method	719
TIM BROWNING and WILL SAWIN	
Optimal lifting for the projective action of $SL_3(\mathbb{Z})$	749
AMITAY KAMBER and HAGAI LAVNER	
Sums of two squares are strongly biased towards quadratic residues	775
OFIR GORODETSKY	