

## Tightness and efficiency of irreducible automorphisms of handlebodies

LEONARDO NAVARRO CARVALHO

Among (isotopy classes of) automorphisms of handlebodies those called irreducible (or generic) are the most interesting, analogues of pseudo-Anosov automorphisms of surfaces. We consider the problem of isotoping an irreducible automorphism so that it is most efficient (has minimal growth rate) in its isotopy class. We describe a property, called tightness, of certain invariant laminations, which we conjecture characterizes this efficiency. We obtain partial results towards proving the conjecture. For example, we prove it for genus two handlebodies. We also show that tightness always implies efficiency.

In addition, partly in order to provide counterexamples in our study of properties of invariant laminations, we develop a method for generating a class of irreducible automorphisms of handlebodies.

[57M99](#); [57N37](#)

### 1 Introduction

#### 1.1 Some history and background

The classification of *automorphisms* (ie self-diffeomorphisms) of a manifold, up to isotopy, is a fundamental problem. Nielsen addressed the case where the manifold is a compact and connected surface and his results were later substantially improved by Thurston (see the work of Nielsen [11; 12; 13], Thurston [17], Handel and Thurston [9] and Fathi, Laudenbach and Poenaro [8]). We briefly state their main result: An automorphism of a surface is, up to isotopy, either *periodic* (ie has finite order), *reducible* (ie preserves an essential codimension 1 submanifold) or *pseudo-Anosov*. We refer the reader to any of [8; 9; 17], or the book by Casson and Bleiler [6] for details, including the definition of a pseudo-Anosov automorphism. The Nielsen–Thurston theory also shows that the reducible case may be reduced to the other two cases. Since periodic automorphisms are relatively easy to understand, the remaining *irreducible* case, ie the pseudo-Anosov case, is the most interesting and rich one. Indeed, pseudo-Anosov automorphisms of surfaces are the subject of intense and wide research (see [17]).

The author and U Oertel have attempted a similar classification of automorphisms of three-dimensional manifolds. First Oertel [14] studied the special case of automorphisms of handlebodies and compression bodies. Recently, the author and Oertel [5] have described a classification of automorphisms of an arbitrary compact, connected, and orientable three-manifold  $M$  satisfying Thurston's Geometrization Conjecture. The classification falls short of being a perfect analogue of the Nielsen–Thurston classification because an automorphism of a reducible three-manifold must, in general, first be written as a composition of two automorphisms, each of which fits into the classification. With the help of standard three-manifolds techniques (eg the JSJ-decomposition, Bonahon's "characteristic compression body", Seifert fiberings, and Heegaard splittings), the authors describe how a given automorphism of a three-manifold  $M$  may be decomposed along suitable "reducing surfaces". The automorphisms which arise and were not previously understood are, in fact, just automorphisms of *handlebodies* and *compression bodies* (defined below). Therefore the path to a better understanding of automorphisms of arbitrary compact three-manifolds leads directly to the study of automorphisms of handlebodies and compression bodies. The goal of this paper is to improve our understanding of automorphisms of handlebodies.

We give precise definitions. A *compression body* is a manifold pair  $(Q, F)$  obtained from a compact and orientable surface  $F$  in the following way. Consider the disjoint union of the product  $F \times I$  and finitely many balls (three dimensional 0–handles)  $B$ . Attach 1–handles to  $(F \times \{1\}) \cup \partial B$ , obtaining  $Q$ . Identifying  $F$  with  $F \times \{0\} \subseteq Q$ , we obtain the compression body  $(Q, F)$ . Then  $F \subseteq Q$  is the *interior boundary* of  $(Q, F)$ , denoted by  $\partial_i Q$ . The *exterior boundary*  $\partial_e Q$  of  $(Q, F)$  is the closure  $\overline{\partial Q - \partial_i Q}$ . We allow empty or non-empty  $\partial F$ , but  $F$  cannot have sphere components. If  $Q$  is homeomorphic to the disjoint union of  $F \times I$  with balls then  $(Q, F)$  is said to be *trivial*.

A *handlebody*  $H$  is a connected compression body whose interior boundary is empty, ie  $H$  is obtained from attaching 1–handles to balls. The *genus* of  $H$  is the rank of  $\pi_1(H)$ .

The following definition is due to Oertel:

**Definition 1.1** An automorphism  $f: H \rightarrow H$  of a handlebody  $H$  is said *reducible* if any of the following hold:

- There exists an  $f$ –invariant (up to isotopy) nontrivial compression body  $(Q, F)$  with  $Q \subseteq H$ ,  $\partial_e Q \subseteq \partial H$  and  $F = \partial_i Q \neq \emptyset$  not containing  $\partial$ –parallel disc components.
- There exists an  $f$ –invariant (up to isotopy) collection of pairwise disjoint, incompressible, non- $\partial$ –parallel and properly embedded annuli.

- $H$  admits an  $f$ -invariant (up to isotopy)  $I$ -bundle structure.

The automorphism  $f$  is called *irreducible* (or *generic*, as in [14]) if

- (1)  $\partial f = f|_{\partial H}$  is pseudo-Anosov, and
- (2) there exists no *closed reducing surface*  $F$ : a closed reducing surface is a surface  $F \neq \emptyset$  which is the interior boundary  $\partial_i Q$  of a nontrivial compression body  $(Q, F)$  such that  $Q \subseteq H$ ,  $(Q, F)$  is  $f$ -invariant (up to isotopy) and  $\partial_e Q = \partial H$ .

An obvious remark is that this definition of irreducible automorphism excludes the periodic case. Also, a “closed reducing surface” in (2) above is indeed closed because the exterior boundary  $\partial_e Q = \partial H$  is closed (recall that the boundaries of  $\partial_i Q$  and  $\partial_e Q$  coincide).

**Theorem 1.2** (Oertel [14]) *An automorphism of a handlebody is either*

- (1) *periodic*,
- (2) *reducible*, or
- (3) *irreducible*.

We note that the theorem above is not entirely obvious. For example, one must show that if an automorphism  $f: H \rightarrow H$  of a handlebody does not restrict to a pseudo-Anosov  $\partial f$  on  $\partial H$ , then  $f$  is actually reducible according to Definition 1.1, or periodic.

Our interest is precisely in the irreducible case, which is in many ways analogous to the pseudo-Anosov case for surfaces. An important similarity is related to the existence of certain invariant projective measured laminations (see [14], and Theorem 1.3 and Remarks 1.4 below). A good part of the original article is dedicated to the construction of these laminations, which depends on many choices. Among these one has to choose a handlebody  $H_0 \subseteq \mathring{H}$  “concentric” with  $H$ , in the sense that the complement  $H - \mathring{H}_0$  is a product. Also, the automorphism  $f: H \rightarrow H$  must be isotoped so that  $H_1 = f(H_0)$  contains  $H_0$  in its interior and  $\bigcup_{i \in \mathbb{Z}} f^i(H_0) = \mathring{H}$ . This yields a nested chain  $H_i \subseteq \mathring{H}_{i+1} \subseteq H_{i+1}$ , where  $H_i = f^i(H_0)$ ,  $i \in \mathbb{Z}$ . Also,  $\mathring{H} = \bigcup_{i \in \mathbb{Z}} H_i$ . Next, a handle decomposition  $\mathcal{H}_0$  of  $H_0$  as union of 0 and 1-handles is needed (alternatively, one can choose a complete system of discs, as in [14]). The 1-handles come with a product structure  $D^2 \times I$ .

We refer the reader to [14] for details on the construction of the laminations. Important properties are summarized in the following theorem and remarks. See Remarks 1.4 for a comment on the singularities of the one-dimensional lamination.

**Theorem 1.3** (Oertel) *Let  $f: H \rightarrow H$  be a generic automorphism of a handlebody. Then there exist a two-dimensional measured lamination  $(\Lambda, \mu)$  of  $\mathring{H}$  with full support, a one-dimensional measured singular lamination  $(\Omega, \nu)$  in  $H_0$  which is transverse to  $\Lambda$  and also with full support,  $\widehat{f}$  isotopic to  $f$  and  $\lambda > 1$  such that*

- (1)  $\widehat{f}(\Lambda, \mu) = (\Lambda, \lambda\mu)$ ,
- (2)  $\widehat{f}(\Omega, \nu) = (\Omega, \lambda^{-1}\nu)$ ,
- (3) *the leaves of  $\Lambda$  are open discs and fill  $H_0$ , in the sense that  $\Lambda \cap H_0$  consists of essential discs in  $H_0$  whose complement  $H_0 - \Lambda$  consists of contractible components,*
- (4)  $\Lambda \cup \partial H$  is closed in  $H$ ,
- (5)  $\Lambda \cap \Omega$  is disjoint from the singular set of  $\Omega$ .

**Remarks 1.4** The handle decomposition  $\mathcal{H}_0$  of  $H_0$  determines handle decompositions  $\mathcal{H}_i$  of any  $H_i = f^i(H_0)$ ,  $i \in \mathbb{Z}$ , through  $f^i$ . Each 1-handle has a fixed product structure  $D^2 \times I$ . Consider the corresponding product foliation by discs. We call a leaf of this foliation a *disc dual to the 1-handle*, or just a *dual disc*. The representative  $\widehat{f}$  can be chosen so that the 1-handles of  $\mathcal{H}_1$  and  $\mathcal{H}_0$  are *compatible* in the sense that 1) dual discs in  $H_1$  intersect  $H_0$  in dual discs and 2)  $I$ -fibers of the dual foliation of a 1-handle of  $\mathcal{H}_0$  by intervals intersect 1-handles of  $\mathcal{H}_1$  in  $I$ -fibers. In fact similar properties hold for any  $\mathcal{H}_i, \mathcal{H}_j$ ,  $i < j$ . For instance, dual discs in  $H_j$  intersect  $H_i$  in dual discs.

Consider the intersection  $\Lambda \cap H_0$  referred to in property (3) in the theorem. It consists of a union of discs dual to the 1-handles of the decomposition  $\mathcal{H}_0$  (a Cantor set of such discs). A similar description also holds for any  $H_i$  by the invariance of  $\Lambda$  under  $f$ . For instance,  $\Lambda \cap H_1$  consists of families of discs essential in  $H_1$  which laminate the 1-handles of  $\mathcal{H}_1$  with dual discs.

Under the same point of view as above one can regard  $\Lambda$  as being obtained from  $\Lambda_0 = \Lambda \cap H_0$  by considering the union of discs  $\Lambda = \bigcup_{i \geq 0} f^i(\Lambda_0)$ , where  $f^i(\Lambda_0) \subseteq f^j(\Lambda_0)$  whenever  $i \leq j$ .

The lamination  $\Omega$  contains a *singular set*  $S(\Omega) = \bigcap_{i \in \mathbb{Z}} f^i(h^0)$ , where  $h^0$  is the union of 0-handles of the decomposition  $\mathcal{H}_0$ . One can choose  $\widehat{f}$  so that  $S(\Omega)$  is finite. The complement  $\Omega - S(\Omega)$  is a lamination of  $H_0 - S(\Omega)$ . That is where the measure  $\nu$  is defined and is its support. Also, the notion of tangency to  $\Omega$  is not defined at  $S(\Omega)$ . Therefore, in general, by saying that a surface  $F$  is *transverse* to  $\Omega$  we assume, in particular, that  $F \cap S(\Omega) = \emptyset$ . The intersection of a 1-handle with  $\Omega$  consists of  $I$ -fibers of the 1-handle.

The problem with [Theorem 1.3](#) is that the laminations, whose construction depends on many choices, are not unique in any reasonable sense. For example, the scalar  $\lambda$ , called *the growth rate of  $f$  with respect to  $\mathcal{H}$*  or just *the growth rate of  $f$* , which is a measure of the complexity of the automorphism, is not unique. This phenomenon is not unlike what happens with automorphisms of surfaces, if one allows the invariant laminations to have monogons for complementary components.

The main problem we shall address here, though not solve, is the following.

**Problem** *Characterize canonical invariant laminations for a given irreducible automorphism of a handlebody.*

In the case of surfaces, a solution is to fix a hyperbolic metric in its interior and work with certain geodesic laminations which, among other properties, realize minimal growth. For automorphisms of handlebodies there is no such solution. Still, there is a minimum in the set of possible growth rates. Naturally, canonical laminations must yield minimal growth, ie the corresponding automorphism must be most *efficient* in its isotopy class. A step (a big step, we believe) in the direction of solving the problem above would then be to characterize minimal growth. Oertel gives a necessary condition [\[14\]](#).

**Theorem 1.5** (Oertel) *If  $\lambda$  is minimal then  $\Lambda$  has the incompressibility property: for each leaf  $L$  of  $\Lambda$  the complement  $L - \mathring{H}_0$  is incompressible in  $\mathring{H} - \mathring{H}_0$ .*

A clear sufficient condition, much stronger than incompressibility, is that the leaves of  $\Omega$  do not “back-track” (with respect to  $\Lambda$ ) in  $H_0$  (see the work of Bestvina and Handel [\[1\]](#)). Not surprisingly it cannot always be realized (see remark below).

We will also consider the problem of constructing examples of irreducible automorphisms of handlebodies. As in any field of mathematics, examples provide a useful investigative tool. The construction of irreducible automorphisms of handlebodies is not an obvious task. The main difficulty resides in proving that a given example does not admit closed reducing surfaces, see [Definition 1.1](#) (the other property, that the restriction to the boundary is pseudo-Anosov, can be achieved with the help of some well-established tools; see the articles by Penner [\[15\]](#) and by Bestvina and Handel [\[2\]](#)).

A result of Bonahon [\[3\]](#) implies that any automorphism of a genus two handlebody whose restriction to the boundary is a pseudo-Anosov automorphism is then irreducible (see also the article by Long [\[10\]](#) and the author’s doctoral thesis [\[4\]](#)). This is not true for higher genus handlebodies.

**Remark 1.6** Bonahon’s result may be used to generate interesting examples. For instance, in [7], Fathi and Laudenbach build an automorphism of a genus two handlebody which (1) restricts to the boundary as a pseudo-Anosov automorphism — thus, as mentioned before, is irreducible — and (2) induces the identity on the fundamental group. In particular, the leaves of  $\Omega$  have to “back-track”. Such an example illustrates the richness of irreducible automorphisms of handlebodies when compared with pseudo-Anosov automorphisms of surfaces, whose complexity is captured on the level of the fundamental group.

## 1.2 Summary of results

Our main results address the problem of characterizing minimal growth of a given irreducible automorphism of a handlebody. We will identify a property on some two-dimensional laminations  $\Lambda$ , which we call “tightness”<sup>1</sup> in [Definition 3.2](#). Essentially,  $\Lambda$  is “tight” if the weighted intersection of its leaves with  $(\Omega, \nu)$  is minimal. The property of being tight is (strictly) stronger than that of Oertel’s incompressibility and (strictly) weaker than that of having “no back-tracking”. We conjecture that it characterizes minimal growth.

**Conjecture 3.5** *The growth rate  $\lambda$  is minimal if and only if  $\Lambda$  is tight.*

This work will prove one direction:

**Theorem 3.6** *If  $\Lambda$  is tight then  $\lambda$  is minimal.*

As for necessity, the problem is harder. We will prove it only under some technical hypotheses ([Proposition 3.7](#)). These hypotheses are useful: we will show that they can be assumed for genus two handlebodies. In this case tightness characterizes minimal growth:

**Corollary 3.8** *Conjecture 3.5 is true for genus two handlebodies.*

Moreover, tightness yields results concerning the growth rates. We prove:

**Corollary 3.23** *If  $\Lambda$  is tight, then the growth rate  $\lambda$  (which is minimal) is less than or equal to the growth rate of the restriction of the automorphism  $f: H \rightarrow H$  to the boundary  $\partial H$  (which is pseudo-Anosov).*

The following is a corollary of [Theorem 3.6](#).

<sup>1</sup>In fact, being tight is a property of the pair of measured laminations.

**Corollary 3.22** *If  $\Lambda$  is tight then the minimal growth  $\lambda_{\min}(f^n)$  of any power  $f^n$  is  $(\lambda_{\min}(f))^n$ .*

From our point of view the measures  $\nu$ ,  $\mu$  on the invariant laminations  $\Omega$ ,  $\Lambda$  and the corresponding growth rate  $\lambda$  come from eigenvectors and eigenvalue of certain incidence matrices of a handle decomposition  $\mathcal{H}$  of the handlebody (or complete disc system  $\mathcal{E}$ ) obtained through  $f$ . The construction depends on such a matrix  $M$  being non-negative and *irreducible*. That means that for any  $1 \leq i, j \leq \dim(M)$  there exists a power  $M^n$ ,  $n \geq 1$ , in which the corresponding entry  $ij$  is not zero. If the automorphism  $f$  is irreducible we can assume that the matrix  $M$  is irreducible (see the paper [14] by Oertel), which is required in the construction of the laminations. Irreducible matrices have many nice spectral properties. For instance its spectral radius, which we denote by  $\lambda(M)$ , is realized by a positive real eigenvalue. We call it the *Perron–Frobenius eigenvalue of  $M$* . The corresponding positive eigenvector, which is well-defined (up to scaling, naturally), is called the *Perron–Frobenius eigenvector*. The following result is useful (see, for example, the articles [16] by Seneta, and [1] by Bestvina and Handel).

**Proposition 1.7** *Let  $M$  be a non-negative and irreducible  $n \times n$  matrix and  $v \in \mathbb{R}^n$  with  $v_i \geq 0$  and  $v \neq 0$ . If*

$$(Mv)_i \leq \lambda v_i \quad \text{for all } i$$

*then  $\lambda(M) \leq \lambda$  and  $v_i > 0$ . If, moreover,  $(Mx)_i < \lambda x_i$  for some  $i$ , then  $\lambda(M) < \lambda$ .*

We will also present a method for generating a certain class of irreducible automorphisms. This method produces examples on higher genus handlebodies. The fact that our techniques fail to prove [Conjecture 3.5](#) for a general automorphism of a handlebody of genus greater than two makes it especially important to study examples in higher genus cases. Our method will depend on the two following results. See [Definition 2.5](#) and [Remark 1.10](#) below for important definitions or the work of Penner [15] and of Bestvina and Handel [1], respectively, for more details.

**Theorem 1.8** (Penner) *Let  $\mathcal{C}$ ,  $\mathcal{D}$  be two systems of closed curves in an oriented surface  $S$  with  $\chi(S) < 0$ . Assume that  $\mathcal{C}$  and  $\mathcal{D}$  intersect efficiently, do not have parallel components and fill  $S$ . Let  $f: S \rightarrow S$  be a composition of Dehn twists: right twists along curves of  $\mathcal{C}$  and left twist along curves of  $\mathcal{D}$ . If a twist along each curve appears at least once in the composition, then  $f$  is isotopic to a pseudo-Anosov automorphism of  $S$ .*

**Theorem 1.9** *Let  $S$  be a compact surface with  $\chi(S) < 0$  and precisely one boundary component. An automorphism  $f: S \rightarrow S$  is pseudo-Anosov if and only if the map  $f_*^n: \pi_1(S) \rightarrow \pi_1(S)$  is irreducible for all  $n > 0$ .*

**Remark 1.10** We recall from Bestvina–Handel [1] the definition of an irreducible automorphism of a free group  $F$ . The *outer automorphism group* of  $F$  is obtained from the group of automorphisms (ie self-isomorphisms) of  $F$  by identifying any two which differ by an inner isomorphism. An “outer automorphism” (ie an equivalence class)  $[\varphi]$  is said *reducible* if the following holds. There are proper free factors  $F_1, \dots, F_k$  of  $F$  such that  $[\varphi]$  permutes the conjugacy classes of the  $F_i$ ’s and such that  $F_1 * \dots * F_k$  is a free factor (not necessarily proper) of  $F$ . If  $[\varphi]$  is not reducible it is said *irreducible*.

The following abuse is present in this paper. When considering an automorphism of a group (typically of a fundamental group) it will often be regarded as its outer automorphism class. For instance,  $f_*^n$  makes sense in the statement of [Theorem 1.9](#) as an outer automorphism. As such it makes sense to wonder whether it is reducible or irreducible (note that  $\pi_1(S)$  is free).

The results of this article are divided in two following sections. In [Section 2](#) we will describe our method for generating examples of irreducible automorphisms. We will develop a particular case and then generalize it in [Theorem 2.6](#). Its statement depends on some technical constructions unsuited for this introduction. We will then use it to build a certain irreducible automorphism of a genus four handlebody ([Example 2.10](#)). It will help in motivating the relevance of the property of tightness. For this reason we shall determine a certain pair of invariant laminations for this automorphism and estimate the corresponding growth rate. The two–dimensional lamination will have Oertel’s incompressibility property.

[Section 3](#) is dedicated to the tightness property. We shall see that the example built in the preceding section does not realize minimal growth. The lack of tightness, which we will define then, will appear naturally there. This will be done through the existence of “tightening discs”, which will be our main objects in dealing with lack of tightness. In the remainder of the section we shall prove the theorems and corollaries on tightness already mentioned.

We adopt the following notations and conventions. Given a topological space  $A$  (typically a manifold or sub-manifold),  $\bar{A}$  denotes its topological closure,  $\overset{\circ}{A}$  its interior and  $|A|$  its number of connected components. If  $H$  is a handlebody we denote a handle decomposition of  $H$  by  $\mathcal{H}$ . By considering co-cores of 1–handles (which we may also call *dual discs*, see [Remarks 1.4](#)) it is clear that a handle decomposition  $\mathcal{H}$  of  $H$  corresponds to a complete system of discs  $\mathcal{E} \subseteq H$ . In fact, the set of handle decompositions and the set of complete disc systems are, up to isotopy, in 1–1 correspondence. This remark is relevant for while the paper by Oertel [14] uses discs systems — because the author focuses on the two–dimensional lamination — we shall use handle decompositions — because we focus more on the one–dimensional



lamination. The incidence matrix associated to a  $\mathcal{H}$  corresponds to the transpose of the incidence matrix associated to the corresponding  $\mathcal{E}$ . There is also an embedded graph  $\Gamma \subseteq H$  dual to  $\mathcal{E}$ , with vertices corresponding to 0–handles of  $\mathcal{H}$  and edges corresponding to 1–handles. We can then regard  $H$  as a fibered neighborhood of  $\Gamma$ . Such embedded graphs are also, up to isotopy, in 1–1 correspondence with handle decompositions and complete disc systems.

I thank Ulrich Oertel for his helpful suggestions in his role as dissertation advisor, and also for laying the foundations on which the research in this paper is built. I thank the referee for reading the paper carefully, and for suggesting improvements to the exposition.

This research was partly supported by CNPq—Brazil, CAPES—Brazil fellowship BEX0292/99-0 and FAPESP—Brazil fellowship 03/06914-2.

## 2 Examples

### 2.1 An example

We will develop a simple particular case of the method that will be obtained in the following subsection. Let  $H$  be a genus 2 handlebody. An automorphism of  $H$  will be described as a composition of Dehn twists along two annuli and a disc. We shall prove that it is irreducible by showing that its restriction to  $\partial H$  is pseudo-Anosov and that, for an algebraic reason, there can be no closed reducing surface. The argument that proves this last part is distinct from that of Bonahon [3] for genus 2 handlebodies and, with the right hypotheses, generalizes to higher (even) genus handlebodies.

**Example 2.1** We first construct a pseudo-Anosov automorphism  $\varphi: S \rightarrow S$  of the once punctured oriented torus  $S$ . It will be defined as a composition of Dehn twists along two curves.

We represent  $S$  as a cross with pairs of opposite sides identified as shown in [Figure 1](#). Fixing a base point in  $S$  we note that  $\pi_1(S)$  is the free group on two generators.

Let  $\alpha_0, \alpha_1$  be simple closed curves as in the figure. It is easy to verify that the systems  $\mathcal{C} = \{\alpha_0\}$  e  $\mathcal{D} = \{\alpha_1\}$  satisfy the hypotheses of [Theorem 1.8](#) (Penner). Let  $T_0^-$  be the left Dehn twist along  $\alpha_0$  and  $T_1^+$  the right twist along  $\alpha_1$ . We define

$$\varphi = T_1^+ \circ T_0^-.$$

By [Theorem 1.8](#)  $\varphi$  is pseudo-Anosov. And by [Theorem 1.9](#) any positive power  $\varphi_*^n$  of the induced isomorphism  $\varphi_*: \pi_1(S) \rightarrow \pi_1(S)$  is *irreducible* (see [Remark 1.10](#)). We note this fact for future use.

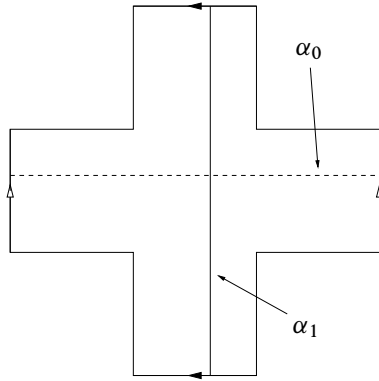

Figure 1: The oriented surface  $S$  and the curves  $\alpha_0, \alpha_1$

We now consider the handlebody  $H = S \times I$ , identifying  $S$  with  $S \times \{1\}$ . The orientation of  $S$  then determines an orientation on  $H$  through inclusion. Now lift  $\phi$  to  $H$ , obtaining  $\phi: H \rightarrow H$ , a composition of twists along the annuli  $A_0 = \alpha_0 \times I$ ,  $A_1 = \alpha_1 \times I$  as in Figure 2. Identifying  $\pi_1(H)$  with  $\pi_1(S)$  yields  $\phi_* = \varphi_*$ .

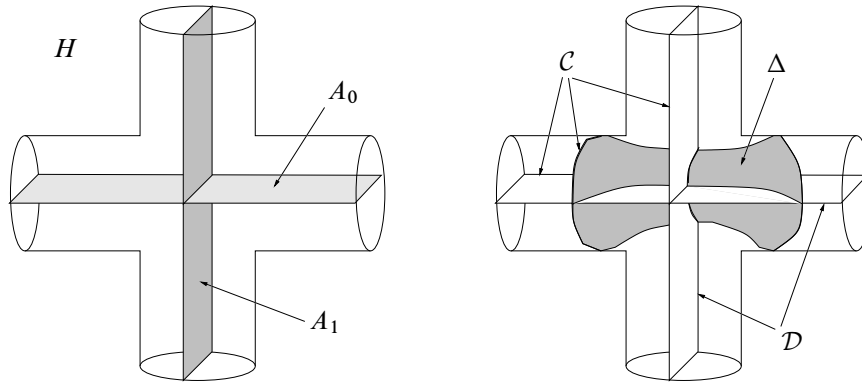

Figure 2: The automorphism  $f$  is defined as a composition of Dehn twists along the annuli  $A_0, A_1$  and the disc  $\Delta$ .

Finally, we will obtain the desired irreducible automorphism  $f: H \rightarrow H$  by composing  $\phi$  with a twist along a disc  $\Delta$ , shown in Figure 2. Let  $T_{\Delta}^+$  be the right Dehn twist along  $\Delta$ . We define:

$$f = T_{\Delta}^+ \circ \phi.$$

**Proposition 2.2** *The automorphism  $f: H \rightarrow H$  is irreducible.*

The lack of closed reducing surfaces will come from the following general lemma. See [Remark 1.10](#) for the definition of a *reducible automorphism of a free group*.

**Lemma 2.3** *Let  $g: H \rightarrow H$  be an automorphism of a handlebody  $H$  such that  $\partial g$  is pseudo-Anosov. If  $g$  is reducible then, for some  $n \in \mathbb{N}$ ,  $g_*^n: \pi_1(H) \rightarrow \pi_1(H)$  is reducible.*

**Remark 2.4** It is clear that the result does not depend on the choice of base point.

**Proof** Since  $\partial g$  is pseudo-Anosov and  $g$  is reducible it follows from [Definition 1.1](#) and [Theorem 1.2](#) that there exists a  $g$ -invariant and nontrivial compression body  $Q$  such that  $\partial_e Q = \partial H$  and  $\partial_i Q \neq \emptyset$ . Let  $F \subseteq \partial_i Q$  be a component of the closed reducing surface  $\partial_i Q$ . By removing 1-handles of  $Q$  it is easy to see that  $F$  bounds a handlebody  $J \subseteq \overset{\circ}{H}$ . By choosing a base point in  $J$  (see the remark above) and omitting the obvious inclusion homomorphisms we claim that

$$\pi_1(H) = \pi_1(J) * G,$$

where  $G$  is not trivial. To see this first consider the connected and nontrivial compression body  $Q' = \overline{H - J}$ , whose boundary decomposes as  $\partial_i Q' = F$  and  $\partial_e Q' = \partial H$ . A compression body structure of  $Q'$  gives it as a product  $F \times I$  to which 1-handles are attached. Regarding  $F \times I \subseteq Q' \subseteq H$  we see that the handlebody  $J' = (F \times I) \cup J$  deformation retracts to  $J$  (so  $\pi_1(J') = \pi_1(J)$  through inclusion). Using the compression body structure of  $Q'$  we can regard  $H$  as obtained from  $J'$  by attaching 1-handles to  $\partial J'$ . Since  $\partial J'$  is connected, we can moreover assume that these 1-handles are attached to a disc in  $\partial J'$ , which gives  $\pi_1(H) = \pi_1(J') * G = \pi_1(J) * G$ , where  $G$  is a free group (whose rank equals the minimal number of 1-handles in a compression body structure of  $Q'$ ). But  $Q'$  is not trivial, so  $G$  is not trivial, proving the claim. Therefore  $\pi_1(J)$  is a proper free factor of  $\pi_1(H)$ .

Let  $g^n$  be the first power of  $g$  preserving  $J$ . Isotoping  $g$  we assume moreover that the base point is fixed by  $g^n$ . From

$$g^n(J) = J$$

it follows that  $g_*^n(\pi_1(J))$  is conjugate to  $\pi_1(J)$ , hence  $g_*^n$  is reducible.  $\square$

**Proof of Proposition 2.2** We need to prove that  $\partial f = f|_{\partial H}$  is pseudo-Anosov and that  $f$  does not admit closed reducing surfaces.

We start by verifying that  $\partial f$  is pseudo-Anosov. It is given as a composition of Dehn twists: left twists along curves of

$$\mathcal{C} = \{(\alpha_0 \times \{1\}), (\alpha_1 \times \{0\})\},$$

(see [Figure 2](#)) and right twists along curves of

$$\mathcal{D} = \{(\alpha_0 \times \{0\}), (\alpha_1 \times \{1\}), \partial\Delta\}.$$

We now note that  $\mathcal{C}, \mathcal{D}$  satisfy the hypotheses of [Theorem 1.8](#) (also see [Definition 2.5](#)), hence  $\partial f$  is pseudo-Anosov.

Now suppose by contradiction that there exists a closed reducing surface. By [Lemma 2.3](#) there exists  $n$  such that  $f_*^n$  is reducible. But  $f = (T_\Delta^+) \circ \phi$  and the twist  $T_\Delta^+$  (along a disc) induces the identity in  $\pi_1(H)$ . Therefore, recalling that  $\pi_1(H)$  is identified with  $\pi_1(S)$ , we have that  $f_*^n = \phi_*^n = \varphi_*^n$ , which was seen before to be irreducible for any  $n$ , a contradiction. This shows that there are no closed reducing surfaces, completing the proof.  $\square$

## 2.2 A method for generating irreducible automorphisms

The construction of [Example 2.1](#) may be generalized to provide a method for generating a larger class of irreducible automorphisms of handlebodies ([Theorems 2.6](#) and [2.8](#)). It partially solves a problem proposed by Oertel [[14](#)].

**Definition 2.5** Let  $(\mathcal{C}, \mathcal{D})$  be a pair of curve systems in a compact, connected and orientable surface  $S$  with  $\chi(S) < 0$ . It is called a *Penner pair in  $S$*  if  $\mathcal{C}, \mathcal{D}$  satisfy the hypotheses of Penner's [Theorem 1.8](#), that is,

- (1) each  $\mathcal{C}, \mathcal{D}$  is a finite collection of simple, closed and pairwise disjoint essential curves without parallel copies,
- (2)  $\mathcal{C}$  and  $\mathcal{D}$  intersect efficiently, do not have parallel components and *fill*  $S$  (ie the components of  $S - (\mathcal{C} \cup \mathcal{D})$  are either contractible or deformation retract to a component of  $\partial S$ ).

Suppose that  $(\mathcal{C}, \mathcal{D})$  is a Penner pair. An automorphism  $\varphi$  of  $S$  obtained from  $\mathcal{C}, \mathcal{D}$  as in [Theorem 1.8](#) is called a *Penner automorphism subordinate to  $(\mathcal{C}, \mathcal{D})$*  (which is in particular pseudo-Anosov).

If  $\partial S \neq \emptyset$  then a properly embedded and essential arc  $\theta$  is called *dual to  $(\mathcal{C}, \mathcal{D})$*  if  $\theta$  intersects  $\mathcal{C} \cup \mathcal{D}$  transversely and in exactly one point  $p \notin \mathcal{C} \cap \mathcal{D}$ .

We constructed the irreducible automorphism in [Example 2.1](#) by lifting a pseudo-Anosov automorphism of a surface to a product and composing it with a twist on a disc. The general method will be similar. Our interest in dual arcs is that we can use them to construct discs that will yield irreducible automorphisms.

Throughout this subsection we fix a compact, connected and oriented surface  $S$  with  $\partial S \neq \emptyset$  and define  $H = S \times I$ , which is a handlebody. We identify  $S$  with  $S \times \{1\} \subseteq H$ , inducing orientation in  $H$ . We also fix a base point in  $S \times \{1\}$  for both  $S$  and  $H$  and identify  $\pi_1(H)$  with  $\pi_1(S)$ .

Given a Penner pair  $(\mathcal{C}, \mathcal{D})$  in  $S$  and a dual arc  $\theta$  we build a disc  $\Delta_\theta$  in  $H$  in the following way. Let  $\gamma$  be the curve of  $(\mathcal{C}, \mathcal{D})$  that  $\theta$  intersects and assume without loss of generality that  $\gamma \subseteq \mathcal{C}$ . Let  $D = \theta \times I \subseteq H$ . Then  $\partial D$  intersects  $\gamma_1 = \gamma \times \{1\}$  in a point. Now let  $\Delta_\theta$  be the *band sum* of  $D$  with itself along  $\gamma_1$ . This means that  $\Delta_\theta$  is obtained from  $D$  and  $\gamma_1$  by the following construction. Consider a regular neighborhood  $N = N(D \cup \gamma_1)$ . Then  $\Delta_\theta = \overline{\partial N - \partial H}$  is a properly embedded disc.

**Theorem 2.6** *Suppose that  $\partial S \neq \emptyset$  has exactly one component. Let  $(\mathcal{C}, \mathcal{D})$  be a Penner pair in  $S$  with dual arc  $\theta$  and  $\varphi: S \rightarrow S$  a Penner automorphism subordinate to  $(\mathcal{C}, \mathcal{D})$ . Let  $\widehat{\varphi}: H \rightarrow H$  be the lift of  $\varphi$  to the product  $H = S \times I$  and  $\Delta_\theta \subseteq H$  the disc constructed from the arc  $\theta$  as above. Then there exists a simple Dehn twist  $T_{\Delta_\theta}: H \rightarrow H$  along  $\Delta_\theta$  such that the composition*

$$\widehat{\varphi} \circ T_{\Delta_\theta}: H \rightarrow H$$

*is an irreducible automorphism of  $H$ .*

The key to the proof is the verification that  $\mathcal{C}$ ,  $\mathcal{D}$  and  $\partial\Delta_\theta$  determine a Penner pair in  $\partial H$ .

**Lemma 2.7** *Let  $S$ ,  $(\mathcal{C}, \mathcal{D})$ ,  $\theta$ ,  $H = S \times I$  and  $\Delta_\theta$  be as in the statement of [Theorem 2.6](#). Let  $\mathcal{C}_i = \mathcal{C} \times \{i\} \subseteq S_i = S \times \{i\}$  and  $\mathcal{D}_i = \mathcal{D} \times \{i\} \subseteq S_i = S \times \{i\}$ , defining  $\mathcal{C}_0, \mathcal{D}_0 \subseteq S_0$  and  $\mathcal{C}_1, \mathcal{D}_1 \subseteq S_1$ . Under these conditions the system*

$$\begin{aligned} \mathcal{Q} &= \mathcal{D}_0 \cup \mathcal{C}_1 \cup \{\partial\Delta_\theta\}, \\ \mathcal{R} &= \mathcal{C}_0 \cup \mathcal{D}_1, \end{aligned}$$

*of curves in  $\partial H$ , determines a Penner pair  $(\mathcal{Q}, \mathcal{R})$  in  $\partial H$ .*

**Proof** We start by making the obvious remarks that  $\mathcal{C}_0, \mathcal{D}_0, \mathcal{C}_1, \mathcal{D}_1 \subseteq \partial H$  and  $\mathcal{C}_0 \cap \mathcal{D}_1 = \emptyset, \mathcal{D}_0 \cap \mathcal{C}_1 = \emptyset$ . Recall that we are assuming that  $\theta \cap (\mathcal{C} \cup \mathcal{D}) \subseteq \gamma \subseteq \mathcal{C}$ . We verify that

- $\partial\Delta_\theta \cap \mathcal{D}_0 = \emptyset$ , because  $(\theta \times \{0\}) \cap \mathcal{D}_0 = \emptyset$  and  $\partial\Delta_\theta \cap S_0$  consists of two arcs in  $S_0$  parallel to  $\theta \times \{0\}$ ,
- $\partial\Delta_\theta \cap \mathcal{C}_1 = \emptyset$ , because  $\partial\Delta_\theta \cap \gamma_1 = \emptyset$  by construction.

Therefore each  $\mathcal{Q} = \mathcal{D}_0 \cup \mathcal{C}_1 \cup \{\partial\Delta\}$  and  $\mathcal{R} = \mathcal{C}_0 \cup \mathcal{D}_1$  is a system of simple closed curves essential in  $\partial H$ . To conclude that  $(\mathcal{Q}, \mathcal{R})$  is indeed a Penner pair it remains to verify that  $\mathcal{Q} \cup \mathcal{R}$  fills  $\partial H$ .

A component of  $S - (\mathcal{C} \cup \mathcal{D})$  either is a disc or an annulus that retracts to  $\partial S$ . Therefore a component of  $\partial H - (\mathcal{C}_0 \cup \mathcal{D}_0 \cup \mathcal{C}_1 \cup \mathcal{D}_1)$  either is a disc or an annulus  $A$  (that retracts to  $\partial S \times I$ ). But  $A \cap \partial\Delta_\theta$  is a union of four arcs essential in  $A$ , hence each component of  $\partial H - (\mathcal{Q} \cup \mathcal{R})$  is a disc. In other words  $\mathcal{Q} \cup \mathcal{R}$  fills  $\partial H$ , completing the proof.  $\square$

Instead of proving [Theorem 2.6](#) we will prove the more general result below, which clearly implies the other. We note that twists on curves of  $\mathcal{C}$ ,  $\mathcal{D}$  in  $S$  lift to twists along annuli in  $H$ . We denote these systems of annuli by  $\widehat{\mathcal{C}}$ ,  $\widehat{\mathcal{D}}$  respectively. The “direction of a twist” along these vertical annuli should be understood as the direction of its restriction to  $S \times \{1\} \subseteq \partial H$ .

**Theorem 2.8** *Let  $(\mathcal{C}, \mathcal{D})$ ,  $S$ ,  $\theta$ ,  $H$  and  $\Delta_\theta$  be as in [Theorem 2.6](#). Let  $f$  be a composition  $f: H \rightarrow H$  of twists along the annuli of  $\widehat{\mathcal{C}}$ ,  $\widehat{\mathcal{D}}$  and the disc  $\Delta_\theta$ : in one direction along the annuli in  $\widehat{\mathcal{D}}$  and in the opposite direction along the annuli in  $\widehat{\mathcal{C}}$  and the disc  $\Delta_\theta$ . If each of these twists appear in the composition at least once  $f$  is irreducible.*

**Proof** We first show that  $f_*^n: \pi_1(H) \rightarrow \pi_1(H)$  is an irreducible automorphism of a free group for any  $n \geq 0$  (hence there can be no closed reducing surface by [Lemma 2.3](#)) and then that  $\partial f = f|_{\partial H}$  is pseudo-Anosov, thus completing the proof that  $f$  is irreducible.

Recall that  $S$  is identified with  $S \times \{1\} \subseteq H$  and  $\pi_1(S)$  with  $\pi_1(H)$ . Let  $T_{\Delta_\theta}$  be a twist along  $\Delta_\theta$ . Since  $(T_{\Delta_\theta})_*: \pi_1(H) \rightarrow \pi_1(H)$  is the identity ( $\Delta_\theta$  is a disc) the hypotheses on  $f$  imply that  $f_* = \varphi_*$  for some Penner automorphism  $\varphi: S \rightarrow S$  subordinate to  $(\mathcal{C}, \mathcal{D})$ . Penner automorphisms are pseudo-Anosov so, given that  $\partial S$  has a single component, it follows from [Theorem 1.9](#) that  $\varphi_*^n$  is an irreducible automorphism of  $\pi_1(S)$  for any  $n \geq 0$ . Therefore  $f_*^n: \pi_1(H) \rightarrow \pi_1(H)$  is irreducible, and then  $f$  does not admit closed reducing surfaces ([Lemma 2.3](#)).

To see that  $\partial f$  is pseudo-Anosov, let  $(\mathcal{Q}, \mathcal{R})$  be as in [Lemma 2.7](#), therefore a Penner pair. By construction the twists that compose  $f$  restrict to  $\partial H$  as twists along curves of  $\mathcal{Q}$  or  $\mathcal{R}$ . It is then straightforward to verify that  $\partial f$  is a Penner automorphism subordinate to  $(\mathcal{Q}, \mathcal{R})$ , hence pseudo-Anosov, completing the proof that  $f$  is irreducible.  $\square$

**Remark 2.9** Note that the conditions that  $S$  is orientable and  $|\partial S| = 1$  imply that  $H$  has even genus.

**Example 2.10** Consider  $S$  a genus 2 surface minus a disc, represented in Figure 3 as an octagon whose sides are identified according to the arrows.

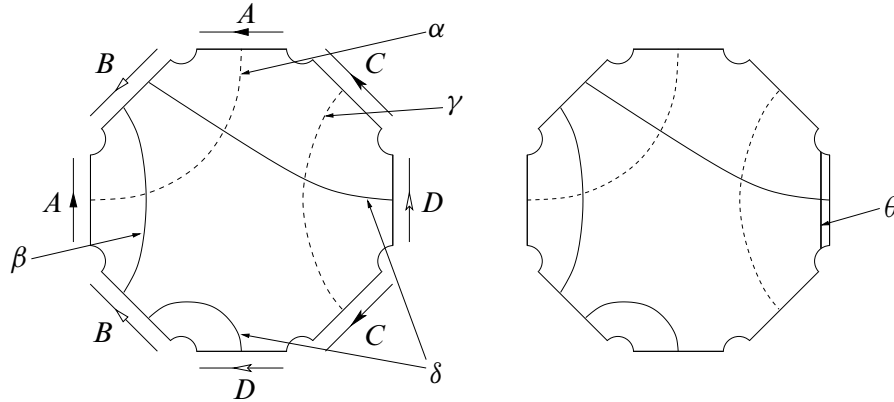

Figure 3: A Penner pair in  $S$ , with dual arc  $\theta$

In the picture there are represented four further curves:  $\alpha$ ,  $\beta$ ,  $\gamma$  and  $\delta$ . Defining

$$\begin{aligned} \mathcal{C} &= \{\beta, \delta\}, \\ \mathcal{D} &= \{\alpha, \gamma\}, \end{aligned}$$

it is easy to check that  $(\mathcal{C}, \mathcal{D})$  is a Penner pair in  $S$ . The automorphism  $\varphi: S \rightarrow S$  defined by

$$\varphi = T_{\beta}^{-} \circ T_{\delta}^{-} \circ T_{\alpha}^{+} \circ T_{\gamma}^{+}$$

is, therefore, a Penner automorphism subordinate to the pair  $(\mathcal{C}, \mathcal{D})$ .

The pair  $(\mathcal{C}, \mathcal{D})$  admits dual arcs. The picture shows one, labelled as  $\theta$ . We consider the corresponding disc  $\Delta_{\theta}$ . Figure 4 shows  $S_0 = S \times \{0\}$ ,  $S_1 = S \times \{1\} \subseteq \partial H$  and how  $\partial\Delta_{\theta}$  intersects them<sup>2</sup>.

Figure 4 also shows the pair  $(\mathcal{Q}, \mathcal{R})$  obtained by Lemma 2.7:  $\mathcal{Q}$  consists of the “solid” lines, including  $\partial\Delta_{\theta}$ , while the “dashed” lines form  $\mathcal{R}$ .

Let  $\widehat{\varphi}: H \rightarrow H$  be the lift of  $\varphi$  to  $H$ . By Theorem 2.8

$$\widehat{\varphi} \circ T_{\Delta_{\theta}}^{-}: H \rightarrow H$$

is an irreducible automorphism, where  $T_{\Delta_{\theta}}^{-}$  is the left twist along  $\Delta_{\theta}$ .

<sup>2</sup>In fact, one can picture the whole  $\partial\Delta_{\theta} \cap \partial H$  in the figure. The only portion of  $\partial H$  not represented is the vertical annulus  $\partial S \times I$ , which  $\partial\Delta_{\theta}$  intersects in four vertical arcs.

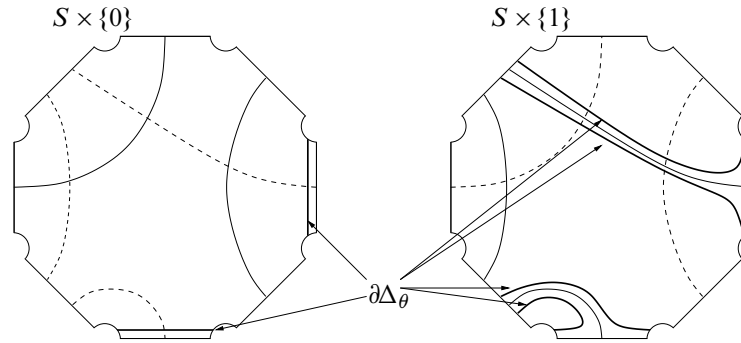
Figure 4: The curve  $\partial\Delta_\theta$  in  $\partial H$ 

### 2.3 The incompressibility condition

**Example 2.11** We continue working with [Example 2.10](#). Now we will determine certain  $f$ -invariant laminations and estimate their corresponding growth rate  $\lambda$ . Recall [Section 1.1](#), especially [Theorem 1.3](#), [Remarks 1.4](#) and [Theorem 1.5](#). We refer the reader to [\[14\]](#) for details on the constructions.

Recall the oriented surface  $S$ , a once punctured genus two surface. Here it will be convenient to regard  $S \times I$  as  $H_0 \subseteq H$ . We now choose a complete system of discs  $\mathcal{E}_0$  in  $H_0$ , as follows. Consider the labelled arcs  $A, B, C$  and  $D \subseteq S$  as in the figure (the sides of the octagon), and construct the discs  $A \times I, B \times I, C \times I, D \times I \subseteq H_0$ . Abusing notation, we use the same labels  $A, B, C$  and  $D$  respectively to represent these discs. Let  $\mathcal{E}_0 = \{A, B, C, D\}$ . From  $\mathcal{E}_0$  we can consider the dual graph  $\Gamma$ . In fact, we will regard  $\Gamma$  as an oriented labeled graph (represented as a spine in [Figure 5](#), on the left). To avoid ambiguities we require that  $\Gamma \subseteq S \times \{\frac{1}{2}\}$ . We now regard  $H_0$  as a neighborhood of  $\Gamma$  and consider the corresponding handle decomposition  $\mathcal{H}_0$  in  $H_0$ .

Together with the handle decomposition we will now choose a representative in the class of  $f$  (which we also label as  $f$ ) and study the associated laminations. These are determined by how the handles of  $H_0$  intersect the handles of  $H_1 = f(H_0)$ . But it is equivalent to consider  $H_{-1} = f^{-1}(H_0) \subseteq H_0$  (apply the diffeomorphism  $f^{-1}$ ), which is easier to picture.

Regarding  $H_0$  as a neighborhood of  $\Gamma$ , we consider  $f^{-1}(\Gamma) = T_{\Delta_\theta}^+ \circ (\widehat{\varphi})^{-1}(\Gamma) \subseteq H_0$  (the disc  $\Delta_\theta$  and the automorphism  $\widehat{\varphi}$  are defined in [Example 2.10](#)). [Figure 5](#), right, shows this image  $f^{-1}(\Gamma)$ , determining how  $\Gamma$ , and hence  $H_0$ , should be pictured in  $H_1$ .

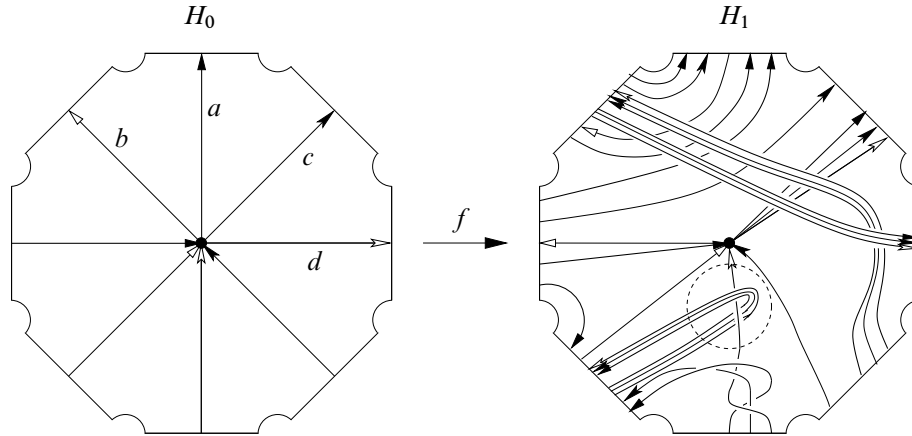

Figure 5: The graph  $\Gamma \subseteq H_0$  and  $\Gamma \subseteq H_1$ 

This intersection pattern determines an  $f$ -invariant measured lamination  $\Lambda$  with full support provided that the incidence matrix corresponding to  $\mathcal{E}_0$  is irreducible. We verify this using the transpose of that matrix, which is the incidence matrix  $M(\mathcal{H}_0)$  for the 1-handles of  $\mathcal{H}_0$ . To do that consider the handle decomposition  $\mathcal{H}_1$  of  $H_1$  induced by  $\mathcal{H}_0$  through  $f$ . The incidence matrix  $M = M(\mathcal{H}_0) = \{m_{ij}\}$  is given by  $m_{ij} = |f(e_i) \cap e_j|$ , where  $f(e_i)$  is a 1-handle of  $\mathcal{H}_1$  and  $e_j$  is a 1-handle of  $\mathcal{H}_0$ . Therefore

$$M = M(\mathcal{H}_0) = \begin{pmatrix} 3 & 1 & 1 & 0 \\ 4 & 1 & 3 & 2 \\ 1 & 0 & 2 & 1 \\ 1 & 0 & 1 & 1 \end{pmatrix},$$

which is indeed irreducible (all entries of  $M^2$  are strictly positive) with a Perron–Frobenius eigenvalue, to three decimal places, of

$$\lambda = \lambda(\mathcal{H}_0) \approx 4.987.$$

We now ask the question of whether  $\lambda$  is the minimal growth in the isotopy class of  $f$  or not. The “no back-tracking” sufficient condition does not apply to this case (for instance, there is an unremovable “back-tracking”, linked on the circled part of [Figure 5](#), right). Oertel’s incompressibility property, a necessary condition, holds here, as methodic — though tedious — computation reveals<sup>3</sup>.

<sup>3</sup>One can carry on this computation in a manner not unlike those in the papers [2; 1] by Bestvina and Handel. Here one just has to be careful with certain back-trackings, which are allowed because of linkings (eg the circled section in [Figure 5](#)).

We see then that, up to this point, we have no criterion to decide whether  $\lambda \approx 4.987$  is minimal or not. In the next section, [Section 3](#), a simple argument shows that this growth rate is not minimal. This will be related to the fact that this lamination is not “tight”.

### 3 Tightness

From now on we assume that  $f: H \rightarrow H$  is an irreducible automorphism of a handlebody  $H$ . We consider a handle decomposition  $\mathcal{H}_0$  of  $H_0$  and the corresponding disc system  $\mathcal{E}_0$ ,  $f$ -invariant measured laminations  $(\Lambda, \mu)$ ,  $(\Omega, \nu)$  and growth rate  $\lambda$ . The one-dimensional lamination  $\Omega$  and its measure  $\nu$  will play important roles throughout this section. Given an immersed surface  $F \subseteq H$  transverse to  $\Omega$  we will denote  $\int_F \nu$  by either  $\nu(F)$  or  $F \bullet (\Omega, \nu)$ . The advantage of the first notation is in its simplicity and will be preferred whenever there are no ambiguities. The advantage of the second is that it emphasizes the object  $\Omega$  supporting  $\nu$ , which will be convenient in certain contexts. We call  $\nu(F) = F \bullet (\Omega, \nu)$  the *weighted intersection* (or just the *intersection*) of  $F$  with  $(\Omega, \nu)$ .

Recall that the goal is to characterize minimal growth.

#### 3.1 Tightening discs

In [Example 2.11](#) we left unproven the claim that Oertel’s incompressibility property does not imply minimal  $\lambda$ . Recall from [Theorem 1.5](#) the incompressibility property, which can also be stated as follows. The two-dimensional lamination  $\Lambda$  has the property if for any  $n > 0$  the leaves of  $\Lambda \cap (H_n - \mathring{H}_0)$  (which are properly embedded planar surfaces with a boundary component in  $\partial H_n$  and the others in  $\partial H_0$ ) are incompressible in  $H_n - \mathring{H}_0$  (see the paper [\[14\]](#) by Oertel).

Let then  $f: H \rightarrow H$  be an irreducible automorphism, assume that an invariant  $\Lambda$  has the incompressibility property and consider the associated growth rate  $\lambda$ . The next schematic example suggests a reason for the fact that this incompressibility does not imply minimality of  $\lambda$ . A handle decomposition  $\mathcal{H}_0$  of  $H_0$  determines, through  $f^i$ , a handle decomposition  $\mathcal{H}_i$  of  $H_i = f^i(H_0)$ ,  $i \in \mathbb{Z}$ . The corresponding incidence matrix  $M(\mathcal{H})$  is assumed to be irreducible, a condition required for the construction of the laminations (see the paragraph preceding [Proposition 1.7](#)).

**Example 3.1** Let  $V$  be a 0-handle of  $\mathcal{H}_1$  and suppose that  $H_0 \cap V$  is as in [Figure 6\(a\)](#), with  $V$  intersecting 1-handles  $e_p$  and  $e_q$  of  $\mathcal{H}_0$ , and  $f(E)$  the image of a disc  $E \in \mathcal{E}_0 = \{E_1, \dots, E_k\}$ .

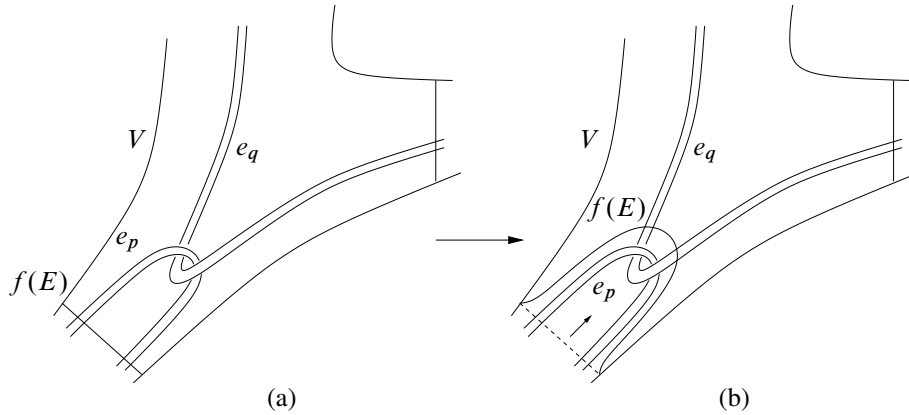

Figure 6: (a) A disc  $f(E)$  dual to a 1–handle of  $H_1$ , intersecting the 1–handle  $e_i$  of  $\mathcal{H}_0$ ; (b) the move that reduces  $\lambda$

Now consider  $M = M(\mathcal{H}_0) = \{m_{ij}\}$ , the incidence matrix for the 1–handles of  $\mathcal{H}_0$ :  $m_{ij} = |f(e_i) \cap e_j|$  counts how many times the 1–handle  $e_j$  (of  $\mathcal{H}_0$ ) crosses the 1–handle  $f(e_i)$  of  $\mathcal{H}_1$ . Recall that we are assuming that  $M$  is irreducible. Its Perron–Frobenius eigenvalue is then  $\lambda$ , the growth rate of  $f$  (with respect to  $\mathcal{H}_0$ ).

Now note that  $E_i$  is transverse to  $\Omega$ , so it makes sense to consider

$$\widehat{v}_i = \nu(E_i),$$

where we recall that  $\nu$  is the transverse measure on  $\Omega$ . That determines a vector  $\widehat{v} = (\widehat{v}_1, \dots, \widehat{v}_k)$ , which is precisely a Perron–Frobenius eigenvector of  $M$ :

$$M\widehat{v} = \lambda\widehat{v}.$$

Suppose that  $\widehat{v}_q < \widehat{v}_p$ . We can isotope  $f$  to replace intersections of  $f(E)$  with  $e_p$  by intersections with  $e_q$  (see Figure 6(b)).

This operation does not change the handle decomposition. Now the new incidence matrix  $M' = \{m'_{ij}\}$  is given by

$$\begin{aligned} m'_{ij} &= m_{ij} && \text{if } ij \neq 1p, 1q; \\ m'_{1p} &= m_{1p} - 2; \\ m'_{1q} &= m_{1q} + 2. \end{aligned}$$

Suppose that  $M'$  is irreducible. In this case recall that  $\widehat{v}_q < \widehat{v}_p$  and consider  $M'\widehat{v}$ :

$$\begin{aligned} (M'\widehat{v})_i &= \lambda\widehat{v}_i && \text{if } i \neq 1; \\ (M'\widehat{v})_1 &= \lambda\widehat{v}_1 - 2\widehat{v}_p + 2\widehat{v}_q < \lambda\widehat{v}_1. \end{aligned}$$

By [Proposition 1.7](#)

$$\lambda(M') < \lambda = \lambda(M),$$

therefore the isotopy reduces the growth rate.

A situation like the one described in the example above indeed happens, see [Example 3.4](#). It not only shows that Oertel's incompressibility property does not imply minimality of the growth rate but also suggests that the weighted intersection  $E \bullet (\Omega, \nu) = \nu(E)$  (where  $E \in \mathcal{E}_0$ ) should be relevant in the search for the minimal growth. We introduce, then, the following definition:

**Definition 3.2** Let  $(\Delta, \partial\Delta) \rightarrow (H, \Lambda)$  be an embedded disc transverse to  $\Omega$ . Consider  $\Delta' \subseteq \Lambda$  such that  $\partial\Delta' = \partial\Delta$ . We say that  $\Delta$  is a *tightening disc* for the triple  $(\Lambda, \Omega, \nu)$  if

$$\nu(\Delta) < \nu(\Delta').$$

The triple  $(\Lambda, \Omega, \nu)$  is said *tight* if there is no tightening disc. We will often abuse notation and say that  $\Lambda$  is tight or not, leaving  $(\Omega, \nu)$  implicit. Accordingly, we may say that a tightening disc for  $(\Lambda, \Omega, \nu)$  is a tightening disc for  $\Lambda$  only.

**Remark 3.3** The requirement that the tightening disc  $\Delta$  is transverse to  $\Omega$  implies that it does not intersect the singular set  $S(\Omega)$ .

We also note that  $\Lambda$  being tight implies that it has the incompressibility property: a compressing disc for  $\Lambda - \mathring{H}_0$  is a tightening disc.

Now we can say that the original lamination in [Example 3.1](#) is not tight, with a tightening disc represented in [Figure 6\(b\)](#). As previously mentioned, that is a hypothetical situation. The following is a specific example.

**Example 3.4** We refer to [Example 2.11](#) and consider the automorphism  $f: H \rightarrow H$  and the handle decomposition  $\mathcal{H}_0$  of  $H_0$  defined then. We consider the disc  $f(B) \subseteq H_1$ , the co-core of a handle of  $\mathcal{H}_1$ .

One can see in [Figure 7](#) a tightening disc  $\Delta$  (represented at the right by a dashed line), with its boundary in a leaf of  $\Lambda \cap H_1$  parallel to  $f(B)$ . Indeed, let  $\Delta' \subseteq f(B)$  be the disc such that  $\partial\Delta' = \partial\Delta$  (represented by a thick line). It is easy to check that

$$\nu(\Delta) = 2\nu(D) < 2(\nu(A) + \nu(C) + \nu(D)) = \nu(\Delta'),$$

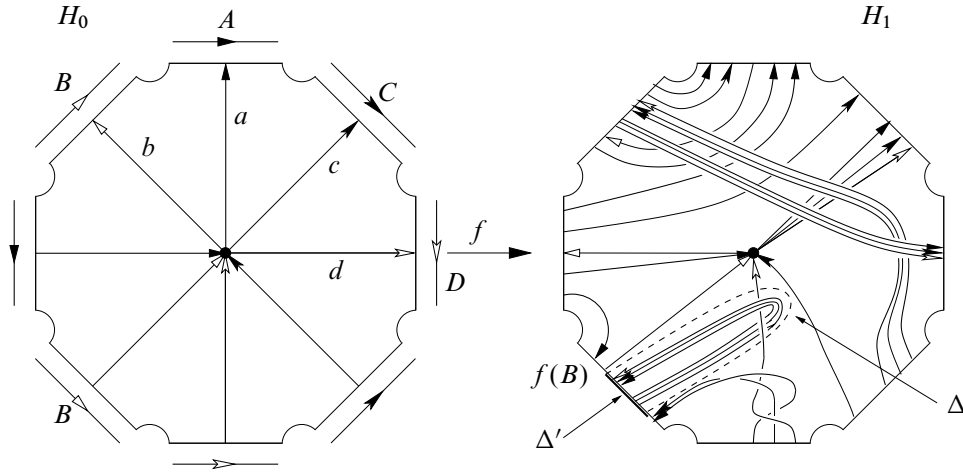

Figure 7: A tightening disc  $\Delta$  in  $H_1$

for  $\nu$  has full support on  $\Omega$ . We now can change  $f$  through an isotopy taking  $\Delta'$  to  $\Delta$ . Figure 8 shows the result of such an isotopy.

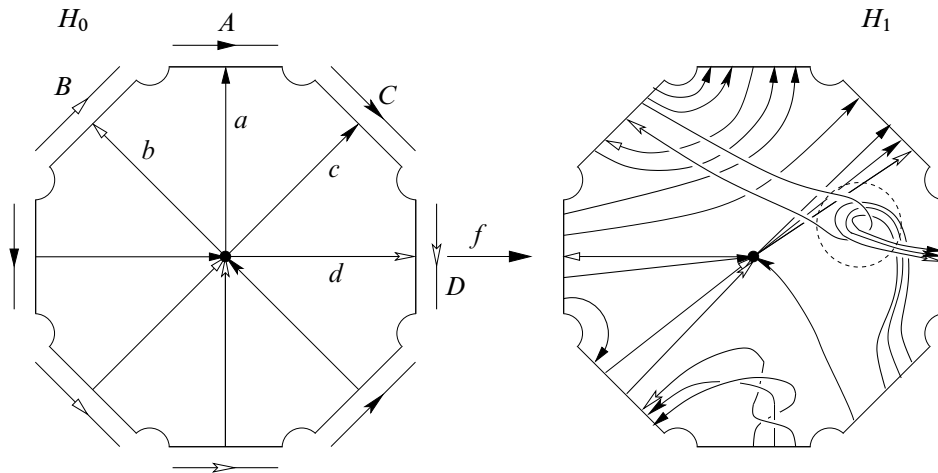

Figure 8: After the growth-reducing isotopy

We verify that the new incidence matrix is:

$$M(\mathcal{H}) = \begin{pmatrix} 3 & 1 & 1 & 0 \\ 2 & 1 & 1 & 2 \\ 1 & 0 & 2 & 1 \\ 1 & 0 & 1 & 1 \end{pmatrix}$$

which is irreducible with Perron–Frobenius eigenvalue  $\lambda(\mathcal{H}) \approx 4.542$  (precise up to three decimals), showing that the previous lamination did not have minimal growth rate.

We are interested in the problem of characterizing minimal growth rate. Considering these examples one should expect tightness to play a role in the solution.

**Conjecture 3.5** *The growth rate is minimal if and only if the lamination  $\Lambda$  is tight.*

At this point we note that tightness is strictly stronger than Oertel’s incompressibility — which is too weak — and strictly weaker than “no back-tracking” — which is too strong.

In the direction of proving the conjecture we will prove the following theorem.

**Theorem 3.6** *If  $\Lambda$  is tight then  $\lambda$  is minimal.*

Concerning the converse we will prove the following proposition.

**Proposition 3.7** *Suppose that all 0–handles of the handle decomposition  $\mathcal{H}$  have valence 2 or 3. If  $\lambda$  is minimal then  $\Lambda$  is tight.*

By *valence* of a 0–handle of  $\mathcal{H}_0$  we mean the number of ends of 1–handles that are attached to it. In other words, consider the graph  $\Gamma$  corresponding to  $\mathcal{H}_0$ . The valence of the vertex corresponding to the 0–handle is its valence. As an application of the technical proposition above we will get the following corollary.

**Corollary 3.8** *Conjecture 3.5 is true if the handlebody has genus 2.*

The proofs will be given in the following subsections.

### 3.2 Strong tightening discs

In this subsection we introduce some technical constructions and results.

The definition of tightening disc that we gave was quite general. We will work with tightening discs having some special properties. These will be called *strong tightening disc* (see [Definition 3.11](#) below). We will show that there is no loss of generality in working with them ([Proposition 3.12](#)).

Consider the handle decomposition  $\mathcal{H}_0$  of  $H_0$ , with 1–handles  $e_1, \dots, e_k$ . We will give weights to these 1–handles, ie assign a positive number  $v_j$  to each 1–handle

$e_j$ . More precisely, given a positive vector  $v = (v_1, \dots, v_k)$ , ( $v_j > 0$ ), we say that the pair  $(\mathcal{H}_0, v)$  is a *weighted handle decomposition of  $H_0$* . In this case we say that  $v$  is a *system of weights in  $\mathcal{H}_0$* . We extend these notions for any level  $i$  through  $f^i$ , so it makes sense to refer to a weighted handle decomposition  $(\mathcal{H}_i, v)$  for any  $H_i = f^i(H_0)$ .

Consider a weighted handle decomposition  $(\mathcal{H}_i, v)$  for  $H_i$  and let  $S$  be an embedded surface intersecting  $H_i$  just in its 1–handles. Suppose further that  $S \cap H_i$  consists of discs dual to the 1–handles  $e_j$  of  $\mathcal{H}_i$ . We define

$$S \bullet (\mathcal{H}_i, v) = \sum_{1 \leq j \leq k} |S \cap e_j| \cdot v_j.$$

If  $E_j$  is a disc dual to the 1–handle  $e_j$  of  $\mathcal{H}_0$  we consider

$$\widehat{v}_j = E_j \bullet (\Omega, v) = v(E_j).$$

Note that  $\widehat{v}_j$  does not depend on the choice of dual disc  $E_j$ . Also, the vector  $\widehat{v} = (\widehat{v}_1, \dots, \widehat{v}_k)$  is a Perron–Frobenius eigenvector of the incidence matrix associated to  $\mathcal{H}_0$  and  $f$ .

**Definition 3.9** Consider  $\widehat{v}$  built above. We regard it as a system of weights in  $\mathcal{H}_0$ . We call  $(\mathcal{H}_0, \widehat{v})$  the *standard weighted handle decomposition of  $H_0$* .

**Remark 3.10** It is clear by the construction above that

$$E_j \bullet (\mathcal{H}_0, \widehat{v}) = E_j \bullet (\Omega, v).$$

Hence, for a general surface  $S$  intersecting  $H_0$  in dual discs,

$$(1) \quad S \bullet (\mathcal{H}_0, \widehat{v}) = S \bullet (\Omega, v).$$

In the definition below  $(\mathcal{H}_0, \widehat{v})$  is standard.

**Definition 3.11** Let  $(\Delta, \partial\Delta) \subseteq (H, \Lambda)$  be an embedded disc and  $\Delta' \subseteq \Lambda$  be such that  $\partial\Delta' = \partial\Delta$ . We say that  $\Delta$  is a *strong tightening disc* if there exists  $n$  such that

- (1)  $\Delta \subseteq H_n$  and  $\partial\Delta \subseteq \partial H_n$ ;
- (2) for any  $0 \leq i \leq n$ ,  $\Delta \cap H_i$  consists of essential discs (in  $H_i$ ) and  $\Delta \cap H_0$  consists, moreover, of discs dual to the 1–handles;
- (3)  $\Delta \cap \Lambda = \partial\Delta$ ;
- (4)  $\Delta \bullet (\mathcal{H}_0, \widehat{v}) < \Delta' \bullet (\mathcal{H}_0, \widehat{v})$ .

**Proposition 3.12** *There exists a tightening disc if and only if there exists a strong tightening disc.*

**Proof** One direction is immediate: a strong tightening disc is a tightening disc by property 4 and the equation (1) above.

We prove the other direction. Let  $\Delta$  be a tightening disc. We will build another one with the required properties. These properties will be realized progressively (not necessarily in the order specified in Definition 3.11 above). For simplicity of notation we will also label these intermediate discs as  $\Delta$ .

**Part 1: property (3)** Let  $n$  be such that  $\Delta \subseteq H_n$ . We first note that  $\partial\Delta$  is contained in a leaf of  $\Lambda \cap H_n$ , which consists of discs dual to the 1–handles of  $H_n$  (see Remarks 1.4). In particular  $\partial\Delta$  is contained in a 1–handle  $e_l$  and fix  $E_l \supseteq \partial\Delta$  the corresponding dual disc. In each other 1–handle  $e_i$  of  $H_n$  choose an arbitrary dual disc  $E_i \subseteq H_n$ . We assume that  $\Delta$  is transverse to  $\bigcup_i E_i$ , including at  $\partial\Delta \subseteq E_j$ .

The main goal is to reduce the complexity  $|\Delta \cap \bigcup_i E_i|$  by performing surgeries and isotopies which preserve the property of being a tightening disc, to eventually yield  $\Delta \cap \bigcup_i E_i = \partial\Delta$ .

Consider  $\Delta \cap \bigcup_i E_i$  (which consists just of closed curves) and choose a curve  $\gamma \subseteq E_j$  that is innermost in some  $E_j$ . Let  $D \subseteq E_j$  and  $D' \subseteq \Delta$  be the discs bounded by  $\gamma$ . There are two cases to consider:

**Case 1:**  $v(D) \leq v(D')$  In this case we perform a surgery in  $\Delta$ , replacing  $D' \subseteq \Delta$  by  $D$  and pushing it a bit away from  $E_j$  (this pushing should be vertical, that is, along the  $I$ –fibers of the product structure  $D^2 \times I$  of the 1–handle  $e_j$ , and “to the side opposite to”  $D'$ ). Since  $\Omega \cap e_j$  consists of  $I$ –fibers, which are preserved by the “pushing” move, the process does not increase  $v(\Delta)$ . It clearly reduces  $|\Delta \cap \bigcup_i E_i|$ .

**Case 2:**  $v(D) > v(D')$  Here  $D'$  is a tightening disc by definition. If  $\gamma \neq \partial\Delta$  then  $|D' \cap \bigcup_i E_i| < |\Delta \cap \bigcup_i E_i|$  and we replace  $\Delta$  with  $D'$ , reducing complexity. If  $\gamma = \partial\Delta \subseteq E_j$  then there are several possibilities:

- There exists another curve  $\gamma' \subseteq (\Delta \cap \bigcup_i E_i)$ ,  $\gamma' \neq \gamma$ , innermost in some  $E_j$ . In this case  $\gamma' \neq \partial\Delta$  and we apply the procedure described above for  $\gamma'$ , reducing  $|\Delta \cap \bigcup_i E_i|$ .
- $\Delta \cap \bigcup_i E_i = \gamma = \partial\Delta$  and we have achieved what was desired.
- $|\Delta \cap \bigcup_i E_i| \geq 2$  and no curve  $\gamma' \subseteq (\Delta \cap \bigcup_i E_i)$ ,  $\gamma' \neq \gamma = \partial\Delta$  is innermost in the dual disc  $E_j$  that contains it. Therefore  $\partial\Delta \subseteq E_j = E_l$  and, if  $i \neq r$ ,  $\Delta \cap E_i = \emptyset$ . Let then  $\gamma' \subseteq \Delta \cap E_l$  be *second innermost* in  $E_l$ , in the sense



that the (interior of the) disc  $D'' \subseteq E_l$  it bounds contains just innermost curves. Since we are assuming that  $\partial\Delta$  is the single innermost curve,  $D'' \cap \Delta = \gamma' \cup \partial\Delta$ . On the other hand,  $\gamma' \subseteq \Delta$  bounds a disc  $\Delta'' \subseteq \Delta$ . We shall prove that  $\Delta''$  is a tightening disc. Indeed recall that  $\Delta'' \subseteq \Delta$  and  $\Delta' \subseteq D''$  and, therefore

$$v(\Delta'') \leq v(\Delta) \quad \text{and} \quad v(\Delta') \leq v(D'').$$

But  $\Delta$  is a tightening disc, ie  $v(\Delta) < v(\Delta')$ . Combining these inequalities one gets that

$$v(\Delta'') < v(D''),$$

ie  $\Delta''$  is a tightening disc. It is also clear that  $|\Delta'' \cap \bigcup_i E_i| < |\Delta \cap \bigcup_i E_i|$ , reducing complexity. We relabel  $\Delta''$  as  $\Delta$ .

In any case complexity is reduced, so eventually  $\Delta \cap \bigcup_i E_i = \partial\Delta$ . Since we can regard the 1–handles of  $\mathcal{H}_n$  as neighborhoods of the  $E_i$ 's, we may assume that those do not intersect  $\Delta$ . In fact, because of the exceptional 1–handle  $e_l$  and disc  $E_l$  which contain  $\partial\Delta$ , this neighborhood argument yields  $\Delta$  intersecting the union of the 1–handles of  $\mathcal{H}_n$  only in a collar neighborhood  $F \subseteq \Delta$  of  $\partial\Delta$ . To obtain the goal that  $\Delta \cap \Lambda = \partial\Delta$  we will, roughly, isotope  $F$  along the  $I$ –fibers of the product structure  $D^2 \times I$  of  $e_l$  up to the point that  $\partial\Delta$  is contained in an extreme leaf of  $\Lambda \cap e_l$  (see [Remarks 1.4](#)).

More precisely, consider an isotopy of  $e_l$  which preserves both of its product foliations  $D^2 \times I$  (preserving the  $I$ –fibers) and takes  $E_l$  to an extreme boundary leaf  $E'_l$  of  $\Lambda \cap e_l$  (an isotopy along the  $I$ –fibers). Here we assume that such a  $E'_l$  is not any of the discs  $D^2 \times (\partial I) \subseteq e_l$ , possibly extending the product structure of  $e_l$  to a slightly larger neighborhood in  $H_n$ . There are two choices of such a boundary leaf  $E'_l$ . We choose the one that is “to the side of  $\Delta$ ”, in the sense that  $F$  is contained in the product  $D^2 \times [a, b] \subseteq D^2 \times I = e_l$  between  $E_l$  and  $E'_l$ . The desired isotopy can be obtained from an isotopy between  $\text{Id}_I$  to a homeomorphism  $I \rightarrow I$  taking  $a \mapsto b$  (or  $b \mapsto a$ , depending on whether  $E_l$  comes before or after  $E'_l$  in the orientation of  $I$ ).

This isotopy fixes  $D^2 \times (\partial I) \subseteq e_l$ , so it extends to an isotopy of  $H_n$  with support in  $e_l$ . We apply it to the disc  $\Delta$ , obtaining  $\Delta'$ . By construction  $F$  is moved away from  $\Lambda \cap e_l$ , yielding  $\Delta' \cap \Lambda = \partial\Delta'$ . Because  $\Omega \cap e_l$  consists of  $I$ –fibers of  $e_l$ , which are preserved by the isotopy, it also holds that  $v(\Delta') = v(\Delta)$  and  $\Delta'$  is a tightening disc satisfying property 3. We relabel  $\Delta'$  as  $\Delta$ .

**Part 2: property (1)** Again let  $n$  be such that  $\Delta \subseteq H_n$ . Let  $L$  be the leaf of  $\Lambda \cap H_n$  containing  $\partial\Delta$ . Hence  $\partial\Delta$  bounds a disc  $\Delta' \subseteq L$ . Consider the annulus  $A = \overline{L - \Delta'}$  ([Figure 9](#)).

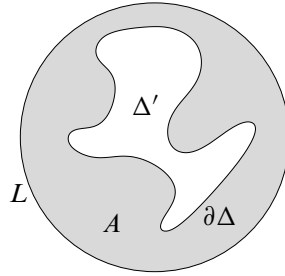

Figure 9: The curve  $\partial\Delta$  separates a disc  $\Delta'$  from an annulus  $A$  in  $L$ .

The desired disc  $D$  (satisfying property 1) will be, essentially,  $\Delta \cup A$ . Just push  $\Delta \cup A$  slightly away from  $L$ , leaving  $\partial(\Delta \cup A)$  unchanged. Since  $\Delta \cup A$  is transverse to  $\Omega$  we can do that preserving  $\nu(\Delta \cup A)$ . Therefore the resulting disc  $D$  has the property that  $\nu(D) = \nu(\Delta \cup A)$ .

It is easy to see that  $D$  still is a tightening disc because the whole operation increased intersection with  $(\Omega, \nu)$  by the same amount  $\nu(A)$  both on the side of the disc and that of the leaf. More precisely,

$$\nu(D) = \nu(\Delta) + \nu(A) < \nu(\Delta') + \nu(A) = \nu(L).$$

We relabel  $D$  as  $\Delta$ , realizing property (1) (and preserving property (3)).

**Part 3: property (4)** At this point we have a tightening disc  $\Delta$  and  $n$  such that  $(\Delta, \partial\Delta) \subseteq (H_n, \partial H_n)$  and  $\Delta \cap \Lambda = \partial\Delta$ .

It is clear that for a sufficiently large  $m$ ,  $\Delta$  does not intersect the 0–handles of  $H_{-m}$ , otherwise  $\Delta$  would intersect the singular set  $S(\Omega)$  (see [Remarks 1.4](#)). In fact, for a sufficiently large  $m$ ,  $\Delta$  is transverse to the  $I$ –fibers of the 1–handles  $D^2 \times I$  of  $H_{-m}$ , otherwise  $\Delta$  would not be transverse to  $\Omega$  (recall that for a 1–handle  $e_i$ ,  $\Omega \cap e_i$  consists of  $I$ –fibers). By taking a sufficiently large  $N$ ,  $f^N(\Delta)$  will intersect  $H_0$  only in its 1–handles and transverse to its  $I$ –fibers. We relabel  $f^N(\Delta)$  as  $\Delta$  and  $n + N$  as  $n$ .

Now note that, since  $\Delta$  is transverse to the fibers of the 1–handles  $e_i$  of  $H_0$ ,  $\Delta \cap e_i$  consists of discs parallel to dual discs. We can then isotope  $\Delta$  so that  $\Delta \cap e_i$  consists of dual discs. This isotopy does not change  $\Delta \bullet (\Omega, \nu)$  and  $\Delta$  still is a tightening disc. From (1)  $\Delta \bullet (\mathcal{H}_0, \widehat{\nu}) = \Delta \bullet (\Omega, \nu)$  (see [Remark 3.10](#)), and it follows that  $\Delta$  satisfies property 4 of a strong tightening disc.

Properties (3) and (1) of  $\Delta$  were preserved, so it only remains to verify property (2).

**Part 4: property (2)** We assume the following technical lemma, which will be proved later.

**Lemma 3.13** *Let  $(E, \partial E) \subseteq (H_m, \partial H_m)$  be an embedded disc intersecting  $H_0$  in discs dual to the 1–handles. If  $E \cap \Lambda$  (which may be empty) is contained in  $\partial E$  then there exists a disc  $E'' \subseteq H_m$  such that*

- $E'' \cap \Lambda \subseteq \partial E'' = \partial E$ ,
- $E'' \cap H_{m-1}$  consists of discs essential in  $H_{m-1}$ ,
- $E'' \cap H_0$  consists of dual discs, and
- $E'' \bullet (\mathcal{H}_0, \widehat{\nu}) \leq E \bullet (\mathcal{H}_0, \widehat{\nu})$ .

So suppose that for some  $0 \leq j \leq n-1$ ,  $\Delta \cap H_j$  does not consist of essential discs. Let  $m-1$  be the greatest such value. Therefore the components of  $\Delta \cap H_m$  are essential discs. Apply the lemma for each such component  $E$ , replacing  $E \subseteq \Delta$  by  $E''$ . Now  $\Delta \cap H_j$  consists of essential discs for all  $m-1 \leq j \leq n$  and we proceed by induction. In the end  $\Delta$  will satisfy property 2 of the definition of strong tightening disc.

We note that the other assertions of the lemma ensure that the other properties (1), (3) and (4) of  $\Delta$  are preserved.

This completes the proof of the proposition up to the proof of [Lemma 3.13](#).  $\square$

**Corollary 3.14** *The lamination is tight if and only if there exists no strong tightening disc.*

### Proof of [Lemma 3.13](#)

Perturb  $E$  in a neighborhood of  $\partial H_{m-1}$  so that it is transverse to  $\partial H_{m-1}$ . We want to change  $E$  so that  $E \cap H_{m-1}$ , which is a planar surface, consists just of essential discs. A natural strategy would be the following: isotope any inessential component of  $E \cap H_{m-1}$  away from  $H_{m-1}$ , so we would have to deal only with essential components. These would be either discs, which we want, or compressible in  $H_{m-1}$ . Simplify the compressible components by compressing them. The problem with this last step is that these compressions, being performed in  $H_{m-1}$ , could introduce undesired intersections with  $H_0$ , increasing  $E \bullet (\mathcal{H}_0, \widehat{\nu})$ . Instead, we will perform surgeries in  $H_m - \mathring{H}_{m-1}$ , where they will not be subject to this problem.

We start by making some quite general comments. “Cut  $H_m$  open along  $\Lambda$ ” (ie take the completion of  $H_m - \Lambda$  under a path-metric inherited from a metric in  $H_m$ ) and let  $C$  be the component that contains  $E$ . We claim that  $\partial H_{m-1} \cap C$  is incompressible in

$C - \mathring{H}_{m-1}$ . Indeed, let  $F$  be a component of  $\partial H_{m-1} \cap C$  and consider the following commutative diagram:

$$\begin{array}{ccc} \pi_1(F) & \xrightarrow{i_1} & \pi_1(C - \mathring{H}_{m-1}) \\ i_2 \downarrow 1-1 & & \downarrow i_3 \\ \pi_1(\partial H_{m-1}) & \xrightarrow[1-1]{i_4} & \pi_1(H_m - \mathring{H}_{m-1}) \end{array}$$

where all homomorphisms are induced by the corresponding inclusion. We claim that  $i_2$  is injective. Indeed, recall that  $\Lambda \cap H_{m-1}$  consists of discs dual to the 1–handles in  $H_{m-1}$  (see [Theorem 1.3](#) and [Remarks 1.4](#)) and hence  $\Lambda \cap \partial H_{m-1}$  consists of essential curves in  $\partial H_{m-1}$ . Also  $i_4$  is injective (because  $H_m - \mathring{H}_{m-1} \simeq \partial H_{m-1} \times I$ ). Therefore  $i_4 \circ i_2$ , and thus  $i_3 \circ i_1$ , is injective. Then  $i_1$  is injective and hence  $F$  is incompressible in  $C - \mathring{H}_{m-1}$ .

From  $\partial E \subseteq \partial H_m$  follows that  $E \cap (\partial H_{m-1} \cap C)$  consists of simple closed curves. Therefore, if  $S = E \cap (C - \mathring{H}_{m-1})$ , then  $\partial S$  has exactly one component in  $\partial H_m \cap C$  (namely,  $\partial E$ ) and all the others in  $\partial H_{m-1} \cap C$ .

We now describe the operations that change  $E$  to yield the desired final  $E''$ . They will be performed in the interior of  $H_m \cap C$ , therefore will not introduce intersections with  $\Lambda$  or with  $\partial H_m$ . For simplicity of notation, we also label the modified discs by  $E$ .

**Process 1** Let  $\gamma$  be a component of  $E \cap (\partial H_{m-1} \cap C)$ . If  $\gamma \subseteq (\partial H_{m-1} \cap C)$  is not essential then it bounds a disc  $D \subseteq (\partial H_{m-1} \cap C)$ . But  $\gamma$  bounds a disc  $D' \subseteq E$  and  $H_m$  is irreducible, therefore we can isotope  $D'$  to  $D$  (also pushing any part of  $E$  that is on the way).

Since  $D \cap H_0 = \emptyset$  this operation does not introduce intersections with  $H_0$ , hence it does not increase  $E \bullet (\mathcal{H}_0, \hat{\nu})$ . It is clear that it also reduces  $|E \cap (\partial H_{m-1} \cap C)|$ . By repeating the process we can assume that  $E \cap (\partial H_{m-1} \cap C)$  consists only of curves that are essential in  $\partial H_{m-1} \cap C$ .

Recall  $S = E \cap (C - \mathring{H}_{m-1})$ . Consider a component  $F$  of  $S$ . If  $F$  is a disc then, by the previous paragraph,  $\partial F \subseteq (\partial H_{m-1} \cap C)$  is an essential curve. Hence  $F$  is a compressing disc for  $\partial H_{m-1} \cap C$  in  $C - \mathring{H}_{m-1}$ , a contradiction. So  $S$  cannot contain discs.

Now let  $\gamma$  be a component of  $E \cap (\partial H_{m-1} \cap C)$  which is innermost in  $E$ . It bounds a disc  $E' \subseteq E$ . From the paragraph above  $E' \subseteq (H_{m-1} \cap C)$ , which will be essential (by

previous considerations). We conclude that when all components of  $E \cap (\partial H_{m-1} \cap C)$  are innermost in  $E$  (in other words, when  $S$  is connected) the proof is complete.

Suppose that that is not the case. The following procedure allows us to assume that  $S$  is incompressible (in  $C - \mathring{H}_{m-1}$ ).

**Process 2** If there exists a compressing disc  $D$  for  $S$  in  $C - \mathring{H}_{m-1}$  we “compress” along it in the following sense. Consider the disc  $D' \subseteq E$  with  $\partial D' = \partial D$ . Irreducibility of  $H_m$  implies that the sphere  $D \cup D'$  bounds a ball. Change  $E$  through an isotopy taking  $D'$  to  $D$  along this ball.

The isotopy does not increase  $E \bullet (\mathcal{H}_0, \hat{\nu})$  because the compressing disc  $D$  does not intersect  $H_0$ . Also, note that  $S \subseteq E$  is a planar surface therefore  $\partial D \subseteq S$  is separating, one of the sides being contained in  $D' \subseteq E$ . Therefore the process, which essentially replaces  $D'$  with  $D$ , reduces  $|\partial S| = |E \cap (\partial H_{m-1} \cap C)|$ . We can repeat the process and assume that  $S$  is incompressible in  $C - \mathring{H}_{m-1}$ .

The next step makes  $S$  connected and hence, as was argued before,  $E \cap H_{m-1}$  consisting of essential discs.

**Process 3** Supposing that  $S$  is not connected, let  $S'$  be a component such that  $\partial S' \subseteq (\partial H_{m-1} \cap C)$ . Now consider  $S'$  in  $H_m - \mathring{H}_{m-1}$ . We verify that  $S'$ , being incompressible in  $C - \mathring{H}_{m-1}$ , is incompressible in  $H_m - \mathring{H}_{m-1}$ . Indeed, if  $D$  is a compressing disc for  $S'$  (in  $H_m - \mathring{H}_{m-1}$ ) we can simplify  $D \cap \Lambda$  by standard “cut and paste” techniques until  $D \cap \Lambda = \emptyset$ . These surgeries will not change  $\partial D$ , so  $D$  still is a compressing disc. But now  $D \subseteq C$ , contradicting incompressibility of  $S'$  in  $C - \mathring{H}_{m-1}$ . So  $S'$  is incompressible in  $H_m - \mathring{H}_{m-1}$ .

But  $H_m - \mathring{H}_{m-1}$  has a product structure  $(H_m - \mathring{H}_{m-1}) \simeq \partial H_{m-1} \times I$ . It is a well known fact that an incompressible surface  $S'$  in such a product with  $\partial S' \subseteq \partial H_{m-1} \times \{0\}$  is parallel to a surface  $S'' \subseteq \partial H_{m-1}$ . Let  $P$  be the product bounded by  $S' \cup S''$ . It is easy to see that  $P \cap \Lambda = \emptyset$ , so we can use the  $I$ -fibers of  $P$  to isotope  $E \cap P$  vertically, through an isotopy taking  $S'$  a bit further than  $S''$ .

We note that this operation reduces  $|S|$ , does not change intersections with  $H_0$  and does not introduce intersections of  $E$  with  $\Lambda$  (recall that  $P \cap \Lambda = \emptyset$ ). Repetition of the process yields  $|S| = 1$ , ie  $S$  is connected and, therefore,  $E \cap H_{m-1}$  consists of essential discs.

We relabel  $E$  as  $E''$ . It satisfies all the desired conditions in the statement of the lemma, completing the proof.  $\square$

### 3.3 Minimality and tightness

We will use strong tightening discs to perform isotopies that reduce the growth rate.

**Lemma 3.15** *If there is a strong tightening disc  $\Delta \subseteq H_1$  then  $\lambda$  is not minimal.*

**Remark 3.16** [Example 3.1](#) shows a particular case of the proposition. The proof follows essentially the same argument that we gave in the example.

**Proof** Let  $(\mathcal{H}_0, \widehat{v})$  be the standard weighted handle decomposition of  $H_0$  (see [Definition 3.9](#)) and consider the weighted decomposition  $(\mathcal{H}_1, \lambda \widehat{v})$ . Since  $\partial \Delta \subseteq H_1 \cap \Lambda$  then  $\partial \Delta = \partial E_{i_0}^1$ , where  $E_{i_0}^1 = f(E_{i_0})$  is a disc dual to a 1–handle of  $H_1$ . Moreover, from (1) (see [Remark 3.10](#)):

$$\Delta \bullet (\mathcal{H}_0, \widehat{v}) < E_{i_0}^1 \bullet (\mathcal{H}_0, \widehat{v}) = \lambda \widehat{v}_{i_0}.$$

Since  $\Delta \cap H_0$  consists of discs dual to the 1–handles of  $\mathcal{H}_0$  we can change  $f$  through an isotopy taking  $E_{i_0}$  to  $\Delta$ , without changing the handle decomposition and preserving “compatibility” (see [Remarks 1.4](#)).

Let  $M' = (m'_{ij})$  be the new incidence matrix. Then  $m'_{ij} = m_{ij}$  if  $i \neq i_0$  and  $m'_{i_0 j} = m_{i_0 j} + d_j$ , where  $d_j \in \mathbb{Z}$  satisfies the following inequality:

$$\sum_{1 \leq j \leq k} d_j \widehat{v}_j < 0.$$

If  $M'$  is irreducible then for  $i \neq i_0$ ,

$$(M' \widehat{v})_i = (M \widehat{v})_i = \lambda \widehat{v}_i$$

but, for the row  $i_0$ ,

$$(M' \widehat{v})_{i_0} = (M \widehat{v})_{i_0} + \sum_{1 \leq j \leq k} d_j \widehat{v}_j < \lambda \widehat{v}_{i_0},$$

hence, by [Proposition 1.7](#),

$$\lambda' = \lambda(M') < \lambda,$$

completing the proof in this case.

If  $M'$  is reducible then, possibly permuting the indices,  $M'$  may be written in the form

$$M' = \left( \begin{array}{c|c} * & * \\ \hline 0 & M'' \end{array} \right)$$

where, for some  $1 \leq r \leq k-1$ ,  $M''$  is irreducible of dimension  $(k-r)$ . From the original system of discs  $\mathcal{E} = \{E_1, \dots, E_k\}$  we pass to an irreducible subsystem  $\mathcal{E}'' = \{E_{r+1}, \dots, E_k\}$ . The transpose of the incidence matrix for these discs is precisely  $M''$ . We will show that also in this case  $\lambda(M'') < \lambda(M)$ .

Since  $M$  is irreducible there exist  $r+1 \leq i_1 \leq k$  and  $1 \leq j_1 \leq r$  such that  $m_{i_1 j_1} > 0$ . Let  $\widehat{v}$  be the  $(k-r)$ -vector defined by  $\widehat{v}_i = \widehat{v}_{i+r}$ ,  $1 \leq i \leq k-r$  (ie  $\widehat{v}$  consists of the last  $k-r$  coordinates of  $\widehat{v}$ ). It follows that, for  $i \neq i_0-r, i_1-r$ ,

$$(M'' \widehat{v})_i \leq (M \widehat{v})_{i+r} = \lambda \widehat{v}_{i+r} = \lambda \widehat{v}_i$$

and, for  $i = i_1-r$ ,

$$(M'' \widehat{v})_{i_1-r} \leq (M \widehat{v})_{i_1} - (m_{(i_1 j_1)}) \widehat{v}_{j_1} < (M \widehat{v})_{i_1} = \lambda \widehat{v}_{i_1} = \lambda \widehat{v}_{i_1-r}.$$

If  $1 \leq i_0 \leq r$  then it follows that  $\lambda'' = \lambda(M'') < \lambda$ , proving the lemma in this case.

If  $r+1 \leq i_0 \leq k$ , in addition to the inequalities above, we further have (for  $i = i_0-r$ )

$$(M'' \widehat{v})_{i_0-r} = \sum_{r+1 \leq j \leq k} (n'_{i_0 j}) \widehat{v}_j \leq \sum_{1 \leq j \leq k} (n'_{i_0 j}) \widehat{v}_j = (M' \widehat{v})_{i_0} < \lambda \widehat{v}_{i_0} = \lambda \widehat{v}_{i_0-r},$$

therefore  $\lambda'' < \lambda$ , completing the proof of the lemma.  $\square$

The hypothesis of  $\Delta$  being contained in  $H_1$  in the statement of [Lemma 3.15](#) is needed because the growth-reducing move has to be performed equivariantly. The difficulty in proving the conjecture is precisely in finding such a disc in  $H_1$ . We can do that under the hypotheses of [Proposition 3.7](#) (ie maximum 0-handle valence 3), as stated in [Lemma 3.17](#) below. The reason is, essentially, that under such conditions every properly embedded essential disc in  $H_0$  which is disjoint from the original disc system is parallel to a disc of this system.

**Lemma 3.17** *Suppose that all 0-handles of the handle decomposition  $\mathcal{H}_0$  have valence 2 or 3. If  $\Lambda(\mathcal{H})$  is not tight then there exists a strong tightening disc in  $H_1$ .*

**Proof** Supposing that  $\Lambda$  is not tight we use [Proposition 3.12](#) to get a strong tightening disc. Among all such discs let  $\Delta$  have minimal *height*, in the sense that if  $H_n$  contains a strong tightening disc then  $\Delta \subseteq H_n$ . Let  $n$  be the smallest integer with the property that  $\Delta \subseteq H_n$ . The lemma states that  $n = 1$ , so assume otherwise that  $n \geq 2$ .

If such a disc  $D$  does not intersect any 0-handles then it is contained in a 1-handle of  $H_{n-1}$ . In this case it is clear that  $D$  is parallel to a dual disc. If  $D$  intersects a 0-handle we can assume it is actually contained in it: using the product structure on the

1–handles that  $D$  intersects, the fact that  $D \cap \Lambda = \emptyset$  and that  $\Lambda \cap H_{n-1}$  contains a representative of any dual disc, we can isotope  $D$  into that 0–handle. Since the handle has valence at most 3, again  $D$  is parallel to a disc dual to a 1–handle. Therefore  $\Delta \cap H_{n-1}$  consists of discs parallel to the co-cores of the 1–handles.

Let  $D$  be such a disc, parallel to the co-core  $E_i^{n-1} \subseteq H_{n-1}$ . Since  $D \subseteq \Delta$  (which is a strong tightening disc) then  $D \cap H_0$  consists of dual discs of  $\mathcal{H}_0$ , so it makes sense to consider  $D \bullet (\mathcal{H}_0, \widehat{\nu})$ . If

$$(2) \quad D \bullet (\mathcal{H}_0, \widehat{\nu}) \geq E_i^{n-1} \bullet (\mathcal{H}_0, \widehat{\nu})$$

for all discs  $D \subseteq \Delta \cap H_{n-1}$  then we can alter  $\Delta$  by an isotopy in such a way that each  $D$  is moved to the corresponding dual disc. This operation does not increase  $\Delta \bullet (\mathcal{H}_0, \widehat{\nu})$  and preserves the other properties of strong tightening discs. Now  $E_i^{n-1} \bullet (\mathcal{H}_0, \widehat{\nu}) = \lambda^{n-1} \widehat{\nu}_i$  is precisely the weight  $E_i^{n-1} \bullet (\Omega, \nu)$  on the  $i$ -th 1–handle of  $H_{n-1}$ . If we apply  $f^{-n+1}$  to  $\Delta$  and  $E_i^{-n+1}$  the inequality

$$f^{-n+1}(D) \bullet (\mathcal{H}_0, \widehat{\nu}) \geq E^i \bullet (\mathcal{H}_0, \widehat{\nu}),$$

is obtained from (2) by multiplying both sides by a factor of  $\lambda^{-n+1}$ . That proves that  $f^{-n+1}(\Delta) \subseteq H_1$  is a strong tightening disc, a contradiction to the assumption  $n \geq 2$ .

The argument above then shows that

$$D \bullet (\mathcal{H}_0, \widehat{\nu}) < E_i^{n-1} \bullet (\mathcal{H}_0, \widehat{\nu})$$

for some  $D \subseteq \Delta \cap H_{n-1}$ . Modifying  $D$  through an isotopy supported in a regular neighborhood of  $\partial H_{n-1}$  (hence preserving  $D \bullet (\mathcal{H}_0, \widehat{\nu})$ ), we can assume that  $\partial D = \partial E_i^{n-1}$ . Now  $D \subseteq H_{n-1}$  is a strong tightening disc, contradicting minimality of  $n$ .

Therefore  $n = 1$  and the proof is complete.  $\square$

We recall and prove:

**Proposition 3.7** *Suppose that all 0–handles of the handle decomposition  $\mathcal{H}$  have valence 2 or 3. If  $\Lambda(\mathcal{H})$  is not tight then  $\lambda(\mathcal{H})$  is not minimal.*

**Proof** Use [Lemma 3.17](#) and apply [Lemma 3.15](#).  $\square$

**Corollary 3.18** *Let  $f: H \rightarrow H$  be a generic automorphism of a handlebody of genus 2. If  $\lambda$  is minimal then  $\Lambda$  is tight.*



**Proof** Consider the handle decomposition  $\mathcal{H}_0$  of  $H_0$  with co-core  $\mathcal{E}_0$ . If every 0–handle has valence 2 or 3 then [Proposition 3.7](#) completes the proof. So we assume that this is not the case. Since  $H$  has genus 2, then it has just one 0–handle with valence 4 and the others (possibly none) with valence 2.

We sketch the proof in the one–dimensional setting: we consider  $\Gamma_0$  the graph corresponding to  $\mathcal{H}_0$ , which will have a valence 4 vertex and some valence 2 vertices. Using the height function in  $H_1 - \overset{\circ}{H}_0$  (projection on the  $I$  coordinate of the product) we obtain graphs  $\Gamma_t$  dual to  $\mathcal{E}_1 \cap H_t$  (when  $t$  is a regular value of the height function in  $\mathcal{E}_1$ ). As  $t$  increases,  $\Gamma_t$  changes by folds. The first fold will have to happen at the valence 4 vertex (folds at valence 2 vertices do not happen by incompressibility). We want to say that this fold replaces the valence 4 vertex by two of valence 3, reducing the problem to the previous case. It could happen that the fold is done along an edge determining a closed loop and, after that, the fold actually replaces the vertex by another one still with valence 4. We can solve this problem by sufficiently subdividing the edges of  $\Gamma$  (ie introducing valence 2 vertices in the interior of the edges).

We now give the more detailed proof in the two–dimensional setting. The fact that one 0–handle has valence 4 means, in genus 2, that  $\mathcal{E}_0$  consists of just two isotopy classes of discs. We want each of these isotopy classes to contain at least two distinct discs of  $\mathcal{E}_0$ . This can be easily achieved by *splittings* (see the paper [\[14\]](#) by Oertel, or the dual *subdivision* of Bestvina and Handel [\[1\]](#)).

Since  $\lambda$  is minimal,  $\Lambda$  has the incompressibility property. In particular  $\mathcal{E}_1 - \overset{\circ}{H}_0$  is incompressible in  $H_1 - \overset{\circ}{H}_0$ . We then have a height function in  $H_1 - \overset{\circ}{H}_0$  with respect to which we may suppose that  $\mathcal{E}_1$  is in Morse position having just saddles as critical points, no pair in the same level (see [\[14\]](#)). Let  $t$  be a bit greater than the first critical value and consider the intermediate  $H_0 \subsetneq H_t \subsetneq H_1$ . Then  $\mathcal{E}_t = \mathcal{E}_1 \cap H_t$  is a system of discs for  $H_t$ . It determines a handle decomposition  $\mathcal{H}_t$ . By regarding  $H_t$  as a “new  $H_0$ ” and following the construction of the invariant measures laminations, we obtain the same original lamination and growth:  $(\Lambda_t, \mu_t) = (\Lambda, \mu)$ ,  $(\Omega_t, \nu_t) = (\Omega, \nu)$  and  $\lambda_t = \lambda$  (see [\[14\]](#) for details).

We claim that  $\mathcal{E}_t$  contains three distinct isotopy classes of discs. To see this we identify  $H_t$  with  $H_0$  through the product structure and note that  $\mathcal{E}_t$  is obtained from  $\mathcal{E}_0 \subseteq H_0$  by replacing two distinct discs by their band sum. This sum is done along a band contained in a 0–handle. If such a 0–handle had valence 2 then the band sum would join two parallel discs, contradicting incompressibility in  $H_1 - \overset{\circ}{H}_0$ , so the band is contained in the 0–handle with valence 4. But the band sum of discs in a 0–handle with valence greater than 3 yields a disc in a new isotopy class. Now recall that we chose  $\mathcal{E}_0$  to have at least two discs in each class. Therefore a single band sum will

preserve at least one disc in each of these original classes, proving the claim that  $\mathcal{E}_t$  contains three classes of discs.

Now that  $\mathcal{E}_t$  contains three distinct isotopy classes of discs, all its 0–handles have valence 3 or 2. Therefore, by [Proposition 3.7](#),  $\Lambda_t = \Lambda$  is tight.  $\square$

**Remark 3.19** There is another interesting point of view, from which we also sketch the proof here. It uses the disc complex of  $H$ . The disc complex  $\mathcal{D}(H)$  of a handlebody  $H$  of genus 2 has dimension 2. We identify each  $H_t$  with  $H$  by collapsing the  $I$ –fibers of the product  $H - \mathring{H}_t \simeq \partial H \times I$ . Now consider the path  $t \mapsto \Lambda \cap H_t$  on  $\mathcal{D}(H)$  (here we use normalized transverse measures as barycentric coordinates). But  $\Lambda \cap H_t$  determines a complete system of discs for any  $t$  so it has at least two isotopy classes of discs. Therefore the path  $t \mapsto \Lambda \cap H_t$  never intersects the 0–skeleton of  $\mathcal{D}(H)$ . But the path intersects infinitely many simplices, so it has to intersect the interior of some 2–simplex of  $\mathcal{D}(H)$ , which corresponds to three distinct isotopy classes of discs. The argument is finished as before.

### 3.4 Tightness implies minimality

The next goal is to prove [Theorem 3.6](#). For that, we need a technical result coming below. If  $G, G' \subseteq H$  are embedded graphs we shall say that  $G'$  follows  $G$  if  $G' \subseteq F_G$ , where  $F_G$  is a fixed fibered neighborhood of  $G$ , the vertices of  $G'$  are contained in the union of the neighborhoods of vertices of  $G$  and the edges of  $G'$  are transverse to the fibers of  $F_G$  over the edges.

Now suppose that  $g: H \rightarrow H$  is an automorphism and that  $g(G)$  follows  $G$ . In this case we define an incidence matrix  $N = N_G(g)$  by  $n_{ij} = |g(e_i) \cap F(e_j)|$ , where  $F(e_j) \subseteq F_G$  is the fibered neighborhood over the edge  $e_j$ . If  $N$  is irreducible we say that its Perron–Frobenius eigenvalue  $\lambda_G = \lambda_G(g)$  is the growth of  $g$  on  $G$ .

In the following we assume that  $f: H \rightarrow H$  and handle decomposition  $\mathcal{H}_0$  of  $H_0$  are fixed. We consider the corresponding disc system  $\mathcal{E}_0$ , dual graph  $\Gamma_0$ , laminations  $(\Lambda, \mu)$ ,  $(\Omega, \nu)$  and growth rate  $\lambda$ .

**Proposition 3.20** *Suppose that there exists  $g$  isotopic to  $f^{-1}$  and graph  $G \subseteq H$  such that  $g(G)$  follows  $G$  with  $\lambda_G < \lambda$ . If  $\Gamma_0$  is isotopic to a graph  $\Gamma'_0$  which follows  $G$  then  $\Lambda$  is not tight.*

**Proof** As usual, the measured lamination  $(\Omega, \nu)$  determines the standard weighted handle decomposition  $(\mathcal{H}_0, \widehat{\nu})$  of  $H_0$ . We use  $(\mathcal{H}_0, \widehat{\nu})$  and  $f^{-n}$  to induce a weighted

handle decomposition  $(\mathcal{H}_{-n}, \widehat{\nu})$  in  $H_{-n} = f^{-n}(H_0)$  (ie the weight in the 1–handle  $f^{-n}(e_i)$  of  $H_{-n}$  is  $\widehat{\nu}_i$ ).

Let  $E_i$  be the co-core of the 1–handle  $e_i$  of  $\mathcal{H}_0$ . By the eigenvalue property of  $\widehat{\nu}$ , for any  $n > 0$

$$\frac{E_i \bullet (\mathcal{H}_{-n}, \widehat{\nu})}{\lambda^n} = \widehat{\nu}_i.$$

The goal of the argument is to find a disc  $\Delta$  isotopic to  $E_i$  (rel  $\partial E_i$ ) such that, for some  $N > 0$ ,

$$(3) \quad \frac{\Delta \bullet (\mathcal{H}_{-N}, \widehat{\nu})}{\lambda^N} < \widehat{\nu}_i.$$

Since  $E_i$  may be chosen as a leaf of  $\Lambda \cap H_0$  and  $\Delta \bullet (\Omega, \nu) = \frac{\Delta \bullet (\mathcal{H}_{-N}, \widehat{\nu})}{\lambda^N}$ , such a  $\Delta$  will then be a tightening disc.

The rough strategy is to isotope  $H_0$  into the fibered neighborhood  $F_G$  of  $G$  and iterate  $g$ . Since its growth is smaller, the number of components of the intersection with the disc  $E_i$  will grow more slowly than originally, what will yield a tightening disc. We shall develop this idea more precisely.

A big part of the proof consists of certain constructions, as follows. We choose an isotopy  $h$  taking  $\Gamma_0$  to  $\Gamma'_0$ . We now consider  $H_0$  as a neighborhood of  $\Gamma_0$  and can obtain an isotopic  $H'_0 \subseteq F_G$ . The weighted handle decomposition of  $H_0$  determines a handle decomposition  $(\mathcal{H}'_0, \widehat{\nu})$  of  $H'_0$ . Also, the fibered structure of  $F_G$  determines a handle decomposition  $\mathcal{G}$  of  $F_G$  in the natural way (ie neighborhoods of vertices correspond to 0–handles and fibered neighborhoods over the edges to 1–handles). By adjusting  $h$  we can assume further that  $\mathcal{H}'_0$  and  $\mathcal{G}$  are *compatible* in the following sense. Any dual disc of a 1–handle of  $\mathcal{G}$  intersects  $H'_0$  in dual discs of  $\mathcal{H}'_0$ .

Now use  $(\mathcal{H}'_0, \widehat{\nu})$  to induce a system of weights on  $\mathcal{G}$  in the following way. Let  $e_0, \dots, e_l$  be the 1–handles of  $\mathcal{G}$  and, for each  $i$ , let  $D_i$  be a dual disc of  $e_i$ . Define

$$(4) \quad (\widehat{\nu}_G)_i = D'_i \bullet (\mathcal{H}'_0, \widehat{\nu}).$$

Such a  $\widehat{\nu}_G$  is well defined: the way the handles of  $\mathcal{G}$  intersect those of  $\mathcal{H}'_0$  assures that (4) above makes sense and does not depend on the choice of disc dual to  $e_i$ . This defines a weighted decomposition  $(\mathcal{G}, \widehat{\nu}_G)$ .

We recall  $g$  from the hypotheses of the lemma. The decomposition  $\mathcal{G}$  determines a decomposition  $\mathcal{G}_{-1}$  of  $g(F_G)$ . We can adjust  $g$  so that  $\mathcal{G}$  and  $\mathcal{G}_{-1}$  are compatible (in particular,  $g(F_G) \subseteq F_G$ ). Through  $g^n$  we can define decompositions  $\mathcal{G}_{-n}$  of  $g^n(F_G)$ . It is clear that these decompositions are automatically compatible.

We now define  $H'_{-n} = g^n(H'_0)$ , also with weighted handle structure  $(\mathcal{H}'_{-n}, \widehat{v})$  defined through  $g^n$ . Clearly  $(\mathcal{H}'_{-n}, \widehat{v})$  is isotopic to  $(\mathcal{H}_{-n}, \widehat{v})$ . It is also clear that if  $-m \leq -n$  then  $\mathcal{G}_{-n}$  and  $\mathcal{H}'_{-m}$  are compatible.

Recall the weight system  $\widehat{v}_G$  defined in (4) above. Now define weighted handle decompositions  $(\mathcal{G}_{-n}, \widehat{v}_G)$ . For a general surface  $S$  the construction implies that (assuming that both sides makes sense)

$$(5) \quad S \bullet (\mathcal{H}'_{-n}, \widehat{v}) = S \bullet (\mathcal{G}_{-n}, \widehat{v}_G).$$

To complete the constructions necessary in this proof, let  $E_i$  be a disc in the original system  $\mathcal{E}_0$ . For a technical reason we extend it through the product structure in  $H - \overset{\circ}{H}_0$  to a disc  $(E, \partial E) \subseteq (H, \partial H)$ . It is clear that  $E \bullet (\Omega, \nu) = E_i \bullet (\Omega, \nu) = \widehat{v}_i$ . We isotope  $E$  and also assume that  $E \cap F_G$  consists of dual discs of  $\mathcal{G}$ .

Recall that  $\lambda_G = \lambda_G(g)$  is the growth of  $g$  on  $G$ . Clearly the sequence

$$n \mapsto \frac{E \bullet (\mathcal{G}_{-n}, v_G)}{(\lambda_G)^n}$$

is bounded. But  $\lambda > \lambda_G$ , therefore

$$\frac{E \bullet (\mathcal{G}_{-n}, v_G)}{\lambda^n} \rightarrow 0$$

and then, for some  $N$ ,

$$(6) \quad \frac{E \bullet (\mathcal{G}_{-N}, v_G)}{\lambda^N} < \widehat{v}_i.$$

By (5) and (6),

$$(7) \quad \frac{E \bullet (\mathcal{H}'_{-N}, \widehat{v})}{\lambda^N} < \widehat{v}_i.$$

Now note that there is an ambient isotopy  $h': H \rightarrow H$  such that  $h'(\mathcal{H}'_{-N}, \widehat{v}) = (\mathcal{H}_{-N}, \widehat{v})$ . By applying  $h'$  to  $(\mathcal{H}'_{-N}, \widehat{v})$ , it follows from (7) above that

$$(8) \quad \frac{h'(E) \bullet (\mathcal{H}_{-N}, \widehat{v})}{\lambda^N} < \widehat{v}_i.$$

We can choose  $h'$  restricting to the identity at  $\partial H$ , so  $\Delta' = h'(E)$  has the property that  $\partial \Delta' = \partial E$ .

Now recall that  $E$  is the extension to  $H$  of the co-core  $E_i$  of a handle of  $\mathcal{H}_0$ . We can use the product structure in  $H - \overset{\circ}{H}_0$  to obtain a disc  $\Delta \subseteq H_0$  from  $\Delta'$ . Clearly  $\partial \Delta = \partial E_i$ ,  $E_i$  may be chosen as a leaf of  $\Lambda \cap H_0$  and  $\Delta \bullet (\mathcal{H}_{-N}, \widehat{v}) = \Delta' \bullet (\mathcal{H}_{-N}, \widehat{v})$ . Therefore (3) follows from (8), showing  $\Delta$  as a tightening disc.  $\square$

**Theorem 3.6** *If  $\Lambda$  is tight then  $\lambda$  is minimal.*

**Proof** It is a corollary of [Proposition 3.20](#) above. We prove the contrapositive, so assume that  $\lambda$  is not minimal. Then there exists another structure  $\widehat{\mathcal{H}}_0$  for some  $\widehat{H}_0$  and representative  $\widehat{f}$  for which the growth rate  $\widehat{\lambda}$  is less than  $\lambda$ . We consider the graph  $\widehat{\Gamma}_0$  corresponding to  $\widehat{\mathcal{H}}_0$ . It is direct that 1)  $(\widehat{f})^{-1}(\widehat{\Gamma}_0)$  follows  $\Gamma_0$  (with  $\lambda_{\widehat{\Gamma}_0} = \widehat{\lambda} < \lambda$ ) and 2) that  $\Gamma_0$  is isotopic to a  $\Gamma'_0 = \widehat{\Gamma}_0$ . By [Proposition 3.20](#)  $\Lambda$  is not tight, completing the proof.  $\square$

**Remark 3.21** [Theorem 3.6](#) can be used to find the minimal growth of some actual examples (see the author's doctoral thesis [\[4\]](#)).

### 3.5 Applications: comparing growth rates

In this subsection we prove some results on the growth rate of an irreducible automorphism with respect to a tight lamination.

The following is a direct corollary of [Theorem 3.6](#).

**Corollary 3.22** *If  $\Lambda$  is tight and  $n > 0$  then  $\lambda_{\min}(f^n) = \lambda^n$ .*

**Proof** Since  $f^n(\Lambda, \mu) = (\Lambda, \lambda^n \mu)$  and  $f^n(\Omega, \nu) = (\Omega, \lambda^{-n} \nu)$ , the growth of  $f^n$  with respect to the handle decomposition that determine  $\Lambda$  and  $\Omega$  is  $\lambda^n$ . But  $\Lambda$  is tight, therefore  $\lambda^n$  is minimal.  $\square$

In Oertel's paper [\[14\]](#) the question is posed whether there is any relation between the growth rate  $\lambda = \lambda(f)$  of a generic automorphism and the growth rate  $\lambda_\partial$  of the pseudo-Anosov restriction  $\partial f = f|_{\partial H}$  to the boundary. The following is another corollary of [Proposition 3.20](#).

**Corollary 3.23** *Let  $f: H \rightarrow H$  be a generic automorphism. If  $\Lambda$  is tight then  $\lambda \leq \lambda_\partial$ .*

**Proof** We prove the contrapositive, so suppose that  $\lambda_\partial < \lambda$ .

Let  $g = f^{-1}$  and let  $\tau$  be a stable train-track of  $\partial g$  (we regard  $\tau$  simply as a graph, with switches for vertices and branches for edges). Let  $F_\tau \subseteq H$  be a fibered neighborhood of  $\tau$  and isotope  $g$  so that  $g(\tau)$  follows  $\tau$ . It is clear that  $\Gamma_0$  is isotopic to a graph  $\Gamma'_0$  which follows  $\tau$ . Indeed,  $\Gamma_0$  is boundary parallel and  $\tau$  fills  $\partial H$ . [Proposition 3.20](#) completes the proof.  $\square$

**Corollary 3.24** *The (minimal) growth rate of a generic automorphism  $f: H \rightarrow H$  of a handlebody of genus 2 is less than or equal to the growth rate of the pseudo-Anosov  $\partial f = f|_{\partial H}$ .*

**Proof** Use [Corollary 3.23](#) and [Corollary 3.18](#).  $\square$

## References

- [1] **M Bestvina, M Handel**, *Train tracks and automorphisms of free groups*, Ann. of Math. (2) 135 (1992) 1–51 [MR1147956](#)
- [2] **M Bestvina, M Handel**, *Train-tracks for surface homeomorphisms*, Topology 34 (1995) 109–140 [MR1308491](#)
- [3] **F Bonahon**, *Ribbon fibred knots, cobordism of surface diffeomorphisms and pseudo-Anosov diffeomorphisms*, Math. Proc. Cambridge Philos. Soc. 94 (1983) 235–251 [MR715046](#)
- [4] **LN Carvalho**, *Generic automorphisms of handlebodies*, PhD thesis, Rutgers University (2003)
- [5] **LN Carvalho, U Oertel**, *A classification of automorphisms of compact 3-manifolds* [arXiv:math.GT/0510610](#)
- [6] **A J Casson, S A Bleiler**, *Automorphisms of surfaces after Nielsen and Thurston*, London Mathematical Society Student Texts 9, Cambridge University Press, Cambridge (1988) [MR964685](#)
- [7] **A Fathi, F Laudenbach**, *Difféomorphismes pseudo-Anosov et décomposition de Heegaard*, C. R. Acad. Sci. Paris Sér. A-B 291 (1980) A423–A425 [MR596088](#)
- [8] **A Fathi, F Laudenbach, V Poenaru**, *Travaux de Thurston sur les surfaces*, Astérisque 66 (1979) [MR568308](#)
- [9] **M Handel, W P Thurston**, *New proofs of some results of Nielsen*, Adv. in Math. 56 (1985) 173–191 [MR788938](#)
- [10] **DD Long**, *Bounding laminations*, Duke Math. J. 56 (1988) 1–16 [MR932854](#)
- [11] **J Nielsen**, *Investigations in the topology of closed orientable surfaces I*, from: “Jakob Nielsen: Collected mathematical papers, vol 1”, (V L Hansen, editor), Contemporary Mathematicians, Birkhäuser (1986) 223–341
- [12] **J Nielsen**, *Investigations in the topology of closed orientable surfaces II*, from: “Jakob Nielsen: Collected mathematical papers, vol 1”, (V L Hansen, editor), Contemporary Mathematicians, Birkhäuser (1986) 348–400
- [13] **J Nielsen**, *Investigations in the topology of closed orientable surfaces III*, from: “Jakob Nielsen: Collected mathematical papers, vol 1”, (V L Hansen, editor), Contemporary Mathematicians, Birkhäuser (1986) 401–459
- [14] **U Oertel**, *Automorphisms of three-dimensional handlebodies*, Topology 41 (2002) 363–410 [MR1876895](#)
- [15] **RC Penner**, *A construction of pseudo-Anosov homeomorphisms*, Trans. Amer. Math. Soc. 310 (1988) 179–197 [MR930079](#)
- [16] **E Seneta**, *Non-negative matrices*, Halsted Press [A division of John Wiley & Sons], New York (1973) [MR0389944](#)

- [17] **W P Thurston**, *On the geometry and dynamics of diffeomorphisms of surfaces*, Bull. Amer. Math. Soc. (N.S.) 19 (1988) 417–431 [MR956596](#)

*Departamento de Matemática Aplicada, IM—Universidade Federal Fluminense  
Niterói, RJ, Brazil*

[leonardo\\_carvalho@vm.uff.br](mailto:leonardo_carvalho@vm.uff.br)

Proposed: Cameron Gordon

Received: 1 September 2004

Seconded: Dave Gabai, Jean-Pierre Otal

Revised: 15 December 2005