



# *Geometry & Topology*

Volume 27 (2023)

Issue 5 (pages 1657–2048)

# GEOMETRY & TOPOLOGY

msp.org/gt

## MANAGING EDITOR

András I. Stipsicz    Alfréd Rényi Institute of Mathematics  
stipsicz@renyi.hu

## BOARD OF EDITORS

Dan Abramovich	Brown University dan_abramovich@brown.edu	Mark Gross	University of Cambridge mgross@dpms.cam.ac.uk
Ian Agol	University of California, Berkeley ianagol@math.berkeley.edu	Rob Kirby	University of California, Berkeley kirby@math.berkeley.edu
Mark Behrens	Massachusetts Institute of Technology mbehrens@math.mit.edu	Frances Kirwan	University of Oxford frances.kirwan@balliol.oxford.ac.uk
Mladen Bestvina	Imperial College, London bestvina@math.utah.edu	Bruce Kleiner	NYU, Courant Institute bkleiner@cims.nyu.edu
Martin R. Bridson	Imperial College, London m.bridson@ic.ac.uk	Urs Lang	ETH Zürich urs.lang@math.ethz.ch
Jim Bryan	University of British Columbia jbryan@math.ubc.ca	Marc Levine	Universität Duisburg-Essen marc.levine@uni-due.de
Dmitri Burago	Pennsylvania State University burago@math.psu.edu	John Lott	University of California, Berkeley lott@math.berkeley.edu
Ralph Cohen	Stanford University ralph@math.stanford.edu	Ciprian Manolescu	University of California, Los Angeles cm@math.ucla.edu
Tobias H. Colding	Massachusetts Institute of Technology colding@math.mit.edu	Haynes Miller	Massachusetts Institute of Technology hrm@math.mit.edu
Simon Donaldson	Imperial College, London s.donaldson@ic.ac.uk	Tom Mrowka	Massachusetts Institute of Technology mrowka@math.mit.edu
Yasha Eliashberg	Stanford University eliash-gt@math.stanford.edu	Walter Neumann	Columbia University neumann@math.columbia.edu
Benson Farb	University of Chicago farb@math.uchicago.edu	Jean-Pierre Otal	Université d'Orleans jean-pierre.otal@univ-orleans.fr
Steve Ferry	Rutgers University sferry@math.rutgers.edu	Peter Ozsváth	Columbia University oszvath@math.columbia.edu
Ron Fintushel	Michigan State University ronfint@math.msu.edu	Leonid Polterovich	Tel Aviv University polterov@post.tau.ac.il
David M. Fisher	Rice University davidfisher@rice.edu	Colin Rourke	University of Warwick gt@maths.warwick.ac.uk
Mike Freedman	Microsoft Research michaelf@microsoft.com	Stefan Schwede	Universität Bonn schwede@math.uni-bonn.de
David Gabai	Princeton University gabai@princeton.edu	Peter Teichner	University of California, Berkeley teichner@math.berkeley.edu
Stavros Garoufalidis	Southern U. of Sci. and Tech., China stavros@mpim-bonn.mpg.de	Richard P. Thomas	Imperial College, London richard.thomas@imperial.ac.uk
Cameron Gordon	University of Texas gordon@math.utexas.edu	Gang Tian	Massachusetts Institute of Technology tian@math.mit.edu
Lothar Götsche	Abdus Salam Int. Centre for Th. Physics gotsche@ictp.trieste.it	Ulrike Tillmann	Oxford University tillmann@maths.ox.ac.uk
Jesper Grodal	University of Copenhagen jg@math.ku.dk	Nathalie Wahl	University of Copenhagen wahl@math.ku.dk
Misha Gromov	IHÉS and NYU, Courant Institute gromov@ihes.fr	Anna Wienhard	Universität Heidelberg wienhard@mathi.uni-heidelberg.de

---

See inside back cover or [msp.org/gt](http://msp.org/gt) for submission instructions.

The subscription price for 2023 is US \$740/year for the electronic version, and \$1030/year (+ \$70, if shipping outside the US) for print and electronic. Subscriptions, requests for back issues and changes of subscriber address should be sent to MSP. Geometry & Topology is indexed by Mathematical Reviews, Zentralblatt MATH, Current Mathematical Publications and the Science Citation Index.

Geometry & Topology (ISSN 1465-3060 printed, 1364-0380 electronic) is published 9 times per year and continuously online, by Mathematical Sciences Publishers, c/o Department of Mathematics, University of California, 798 Evans Hall #3840, Berkeley, CA 94720-3840. Periodical rate postage paid at Oakland, CA 94615-9651, and additional mailing offices. POSTMASTER: send address changes to Mathematical Sciences Publishers, c/o Department of Mathematics, University of California, 798 Evans Hall #3840, Berkeley, CA 94720-3840.

---

GT peer review and production are managed by EditFLOW<sup>®</sup> from MSP.

PUBLISHED BY

 **mathematical sciences publishers**  
nonprofit scientific publishing

<http://msp.org/>

© 2023 Mathematical Sciences Publishers

# A sharp lower bound on fixed points of surface symplectomorphisms in each mapping class

ANDREW COTTON-CLAY

Given a compact, oriented surface  $\Sigma$ , possibly with boundary, and a mapping class, we obtain sharp lower bounds on the number of fixed points of a surface symplectomorphism (ie area-preserving map) in the given mapping class, both with and without nondegeneracy assumptions on the fixed points. This generalizes the Poincaré–Birkhoff fixed point theorem to arbitrary surfaces and mapping classes. These bounds often exceed those for non-area-preserving maps. We give a fixed point bound on symplectic mapping classes for monotone symplectic manifolds in terms of the rank of a twisted-coefficient Floer homology group, with computations in the surface case. For the case of possibly degenerate fixed points, we use quantum-cup-length-type arguments for certain cohomology operations we define on summands of the Floer homology.

37E30, 37J10, 53D40; 37C25

## 1 Introduction

### 1.1 Sharp fixed point bounds for surface symplectomorphisms

**1.1.1 Overview** Let  $(\Sigma, \omega)$  be a compact surface of negative Euler characteristic,<sup>1</sup> possibly with boundary, with  $\omega$  a symplectic form (ie area form). For any mapping class we give sharp lower bounds on the number of fixed points of an area-preserving map  $\phi$  in the mapping class, both in the case in which  $\phi$  is assumed to have nondegenerate fixed points<sup>2</sup> and in the general case in which degenerate fixed points are allowed. This generalizes the Poincaré–Birkhoff fixed point theorem, which states that area-preserving twist maps of the annulus have at least two fixed points, to arbitrary surfaces and mapping classes.

© 2023 MSP (Mathematical Sciences Publishers). Distributed under the Creative Commons Attribution License 4.0 (CC BY). Open Access made possible by subscribing institutions via [Subscribe to Open](#).

<sup>1</sup>Our results extend to the nonnegative Euler characteristic case but these exceptional cases would be cumbersome to carry around. All of these cases are already understood.

<sup>2</sup>That is, the fixed points of  $\phi$  are cut out transversally in the sense that  $\det(1 - d\phi_x) \neq 0$  for fixed points  $x$ .

**1.1.2 Traditional lower bound from Nielsen theory** A traditional lower bound, which is sharp for non-area-preserving maps on surfaces, comes from Nielsen theory. Given a symplectomorphism  $\phi: \Sigma \rightarrow \Sigma$  let  $M_\phi \rightarrow S^1$  be the mapping torus as a  $\Sigma$ -bundle over  $S^1$ , and let  $\Gamma(M_\phi)$  be its space of sections. A Nielsen class  $\eta \in \pi_0(\Gamma(M_\phi))$  of a fixed point  $x$  of a map  $\phi$  is its homotopy class when considered as a constant section of the mapping torus. The index of a Nielsen class  $\eta$ , denoted by  $\text{ind}(\eta)$ , is given by the sum of the topological indices<sup>3</sup> of each fixed point in the class  $\eta$ . This quantity is invariant under deformation. The traditional lower bound on fixed points when there is a nondegeneracy condition is given by  $\sum_\eta |\text{ind}(\eta)|$ , as nondegenerate fixed points have index  $\pm 1$ . In the general case with no nondegeneracy condition, the traditional lower bound is given by the number of Nielsen classes with nonzero index.

**1.1.3 Mapping classes and Thurston's classification** Let  $\text{Diff}^+(\Sigma)$  denote the space of orientation-preserving diffeomorphisms of  $\Sigma$ . For closed surfaces, mapping classes are elements of  $\pi_0(\text{Diff}^+(\Sigma))$ . For surfaces with boundary, we define  $\text{Diff}_\partial^+(\Sigma)$  to be the space of orientation-preserving diffeomorphisms with no fixed points on the boundary, and use the term mapping classes to refer to elements of  $\pi_0(\text{Diff}_\partial^+(\Sigma))$ , though this is not standard. By Moser's trick, in dimension two, these are homotopy equivalent to the versions with  $\text{Diff}$  replaced by  $\text{Diff}_{\text{vol}} = \text{Symp}$ .

We state our results in terms of Thurston's classification of surface diffeomorphisms (see Thurston [20] and Fathi, Laudenbach and Poénaru [4]), which states that given a compact, oriented surface  $\Sigma$  (with or without boundary) every element of  $\pi_0(\text{Diff}^+(\Sigma))$  is precisely one of the following types:

- **Periodic (finite order)** For some representative  $\phi$ , we have  $\phi^\ell = \text{id}$  for some  $\ell \in \mathbb{Z}_{>0}$ .
- **Pseudo-Anosov** Some singular representative  $\phi$  preserves two transverse singular measured foliations, expanding the measure on one and contracting the measure on the other. See Cotton-Clay [1] for symplectic smoothings of these singular representatives.
- **Reducible** Some representative  $\phi$  fixes setwise a collection of curves  $C$ , none of which are nullhomotopic or boundary parallel (and the mapping class is not periodic).

<sup>3</sup>The degree of the induced map on  $H_1$  of a deleted neighborhood of the fixed point  $x$ .

In the reducible case, we call such a curve  $C$  above a *reducing* curve. Cutting along a maximal collection of pairwise nonhomotopic reducing curves  $C$  gives a map on each component of  $\Sigma \setminus C$ , given by the smallest power of  $\phi$  which maps that component to itself, which is periodic or pseudo-Anosov. We call these components of  $\Sigma \setminus C$  *reducible components* or *geometric components* when extending this to the case of the entire surface for nonreducible maps. We say a component *abuts* the reducing curves making up its boundary, as well as any curves making up its actual boundary.

**1.1.4 Fixed annuli and standard representatives** To understand fixed points of surface symplectomorphisms, we are interested in components which map to themselves. In addition to the geometric components described above, we must extend the notion of *components* to allow for a number of *fixed annuli* between geometric components or near a boundary when there is sufficient twisting along the reducing curve or at a boundary curve. After standard perturbations (see Section 4.1.1), near a reducing curve or boundary curve  $C$ , we choose *standard representatives* to have twisting regions (à la Dehn twists) connecting the components. Such a twisting region may have any number (in  $\mathbb{Z}_{\geq 0}$ ) of circles of fixed points, which we think of as fattened to annuli and consider as *fixed annuli*. See Section 4.1.2 for a definition and, for an optional further elucidation of these, see Section 4.1.3 relating counting the number of these to a variant of fractional Dehn twist coefficients, related to the concept in Honda, Kazez and Matic [7].

These fixed annuli are important to consider as they can show up in one of two types of components (see Section 1.1.5 below) which contribute to excess fixed points over the traditional Nielsen theory lower bound. Indeed, the case of the Poincaré–Birkhoff fixed point theorem can be thought of as a solitary fixed annulus in this context.

**1.1.5 Excess over Nielsen lower bound: components of types A and B** In what follows, these fixed annuli are additionally considered *components*, on which the induced map is considered to be the identity. Additionally, we consider mapping classes on a surface with boundary with fixed annuli reducible in  $\pi_0(\text{Diff}_\partial^+(\Sigma))$ , even if they are not reducible in  $\pi_0(\text{Diff}^+(\Sigma))$ .

There are two settings, in terms of standard representatives, in which the minimum for area-preserving maps exceeds the topological minimum from Nielsen theory. Both involve components on which the induced map is the identity:

- **Components of type A** We say a component is of type A if
  - its induced map is the identity,

- it is genus-zero but nonannular,
- it does not abut with twist  $0 \in \mathbb{Q}$  any pseudo-Anosov components,
- all its boundaries are nullhomologous or boundary-parallel, and
- all its boundaries have twist in  $\mathbb{Q}$  with the same sign or 0.
- **Components of type B** We say a component is of type B if
  - it is a fixed annulus (as above), and
  - it is nullhomologous or boundary-parallel.

Here *twist* is in the sense of the fractional Dehn twist coefficient of [7].

### 1.1.6 Theorems and discussion

**Theorem 1.1** *Let  $(\Sigma, \omega)$  be a compact, oriented surface, possibly with boundary, with area form  $\omega$ . The minimum number of fixed points of an area-preserving map with nondegenerate fixed points in a mapping class  $h$  is given by*

$$\begin{cases} \sum_{\eta} |\text{ind}(\eta)| & \text{if } h \text{ is periodic or pseudo-Anosov,} \\ \sum_{\eta} |\text{ind}(\eta)| + 2A + 2B & \text{if } h \text{ is reducible.} \end{cases}$$

Here  $A$  is the number of components of type A, and  $B$  the number of components of type B, of a standard representative of the mapping class  $h$ .

The upper bound here is given by construction, which comes from perturbing maps which are nice with respect to the Nielsen–Thurston geometry, which we call standard form maps, with particular symplectic vector fields. The lower bound comes from Floer homology computations for these standard form maps with certain twisted coefficients, based on computations we performed in [1], plus a result discussed below showing how computations with appropriate twisted coefficients give fixed point bounds over entire mapping classes.

In this case, counting nondegenerate fixed points, components of types A and B each contribute an additional two fixed points, analogous to the Poincaré–Birkhoff fixed point theorem, which can be thought of as the case of a solitary fixed annulus.

**Theorem 1.2** *The minimum number of fixed points of an area-preserving map in a mapping class  $h$  is given by*

$$\begin{cases} \#\{\eta : \text{ind}(\eta) \neq 0\} & \text{if } h \text{ is periodic or pseudo-Anosov,} \\ \#\{\eta : \text{ind}(\eta) \neq 0\} + A + 2B & \text{if } h \text{ is reducible,} \end{cases}$$

where  $A$  and  $B$  are as in Theorem 1.1.

To clarify Theorem 1.2, both components contributing to  $A$  and components contributing to  $B$  contribute two to the minimum number of fixed points, but those contributing to  $A$  have nonzero index and thus have already contributed one in the traditional Nielsen bound. For type A components, degeneracy allow collapsing down to two fixed points, but (also with type B components) no further.

Though we have restricted to surfaces of negative Euler characteristic, we note that a twist map on the annulus may be considered to have one component of type B, and the two fixed points guaranteed by the Poincaré–Birkhoff fixed point theorem appear in the  $2B$  term here.

Again the upper bound is given by construction. The lower bound comes from “quantum cup-length” computations for a certain cohomology operation<sup>4</sup> on the summand of Floer homology corresponding to the given Nielsen class, plus a compactness argument of Taubes. This cohomology operation is morally given by counting intersections of holomorphic cylinders with cycles in  $H_1(S, \partial S)$  for  $S$  a reducible component on which the map is the identity whose fixed points are in the Nielsen class. The fact that this is well defined comes from an understanding of the homotopy type of the component of the space of sections  $\Gamma(M_\phi)$  of  $M_\phi \rightarrow S^1$  corresponding to the given Nielsen class, plus an algebraic invariance result given in [1] for certain types of cohomology operations on Floer homology.

## 1.2 Fixed point bounds for monotone symplectic manifolds.

Let  $(X, \omega)$  be a symplectic manifold, and consider the problem of finding fixed point bounds for symplectic mapping classes, which are connected components of  $\text{Symp}(X)$ .

The symplectic Floer homology of a symplectomorphism  $\phi$  is the homology of a chain complex generated by the fixed points of  $\phi$ ; see Section 2 for more details. Thus the rank of Floer homology gives a bound on the number of fixed points of  $\phi$ , and results on the invariance of Floer homology under deformation of  $\phi$  give more general fixed point bounds. A main challenge in obtaining fixed point bounds for symplectic mapping classes is that we are interested in fixed point bounds on connected components of  $\text{Symp}(X)$  as opposed to on  $\text{Ham}(X)$ –cosets of  $\text{Symp}(X)$ . Floer homology is invariant under Hamiltonian perturbations between maps with nondegenerate fixed points, so as long as we can define it on a given  $\text{Ham}(X)$ –coset, the rank of the Floer homology for

<sup>4</sup>We note that the usual module structure over the quantum cohomology of  $\Sigma$  vanishes in the situation of interest.

any map in the coset is a bound on the number of fixed points for all nondegenerate maps in the coset.

To deal with this, we give a general method for finding fixed point bounds for symplectic mapping classes on monotone symplectic manifolds  $(X, \omega)$ . We say that  $(X, \omega)$  is monotone if  $[\omega] \in H^2(X)$  is a positive multiple of  $c_1(X)$ .<sup>5</sup> The method consists of performing a single Floer homology computation, for a suitable map  $\phi$  in the symplectic mapping class, with suitable twisted coefficients. Along the way, we show that Floer homology computations for one suitable map  $\phi$  with various twisted coefficients give computations of  $HF_*(\psi, \Lambda_\psi)$ , the Floer homology of  $\psi$  with its natural Novikov coefficients  $\Lambda_\psi$ , for any  $\psi$  in the symplectic mapping class.

We identify a subset of each mapping class, which we call *weakly monotone*, such that Floer homology is defined with any coefficients and is invariant under deformations through such maps. In [1] we have shown that standard form maps on surfaces are in this subset. Let  $\omega_\phi$  be the two-form on  $M_\phi$  induced by  $\omega$  on  $\Sigma \times \mathbb{R}$  and let  $c_\phi$  be the first Chern class of the vertical tangent bundle of  $M_\phi \rightarrow S^1$ .

**Definition 1.3** A map  $\phi: X \rightarrow X$  is *weakly monotone*<sup>6</sup> if  $[\omega_\phi]$  vanishes on  $T_0(M_\phi)$ , where  $T_0(M_\phi) \subset H_2(M_\phi; \mathbb{R})$  is generated by tori  $T$  with  $c_\phi(T) = 0$  such that  $\pi|_T: T \rightarrow S^1$  is a fibration with fiber  $S^1$ , where the map  $\pi: M_\phi \rightarrow S^1$  is the projection.

In Section 3.1 we define a flux map. Monotone maps have zero flux, which allows their Floer homology with untwisted coefficients to be computed. Weakly monotone maps need not have zero flux, but they still have well-defined Floer homology with untwisted coefficients. Further, if we apply well-chosen twisted coefficients, the Floer homology gives a lower bound on fixed points for non-weakly-monotone maps in the same symplectic mapping class.

Consider a flux map  $\text{Flux}(\phi): N_h \rightarrow \mathbb{R}$ . Here  $N_h$  denotes the image under the map  $H_2(M_\phi) \rightarrow \ker(\phi_* - \text{id}) \subset H_1(\Sigma)$  of  $\ker(c_\phi) \subset H_2(M_\phi)$ . Let  $N'_h$  be the image under the map from the long exact sequence for the mapping torus fibration  $H_2(M_\phi) \rightarrow \ker(\phi_* - \text{id}) \subset H_1(\Sigma)$  of the subset  $T_0(M_\phi) \subset \ker(c_\phi) \subset H_2(M_\phi)$ .

<sup>5</sup>If the multiple is negative, everything goes through similarly if there are no spheres with Chern class above  $-n - 2$ , where  $n$  is half the (real) dimension of  $X$ . Even failing this, we should be able to use virtual moduli space or polyfold methods. These are technical issues, but the statement that  $[\omega]$  is some multiple of  $c_1(X)$  seems vital to our argument.

<sup>6</sup>We used “weakly monotone for every Nielsen class” to refer to the same concept in [1].



**Theorem 1.4** *Let  $X$  be a monotone symplectic manifold,  $h$  a symplectic mapping class on  $X$ , and  $\phi \in h$ .*

- (i)  $\text{Flux}(\phi): N_h/\text{tors} \rightarrow \mathbb{R}$  is well-defined.
- (ii)  $\text{Flux}(\phi)|_{N_h'/\text{tors}} = 0$  if and only if  $\phi$  is weakly monotone.
- (iii) Let  $\phi$  be such that  $\text{Flux}(\phi)|_{N_h} = 0$ . Then the rank of  $HF_*(\phi; Q(\mathbb{Z}/2[N_h'/\text{tors}]))$  gives a lower bound on the rank  $HF_*(\psi; \Lambda_\psi)$  for  $\psi$  any map in the class  $h$ , where  $\Lambda_\psi$  is the Novikov ring over which  $HF_*(\psi)$  is naturally defined, and thus gives a lower bound on the number of fixed points of a map in the mapping class with nondegenerate fixed points.

Here  $Q(\mathbb{Z}/2[N_h'/\text{tors}])$  is the quotient field of the group ring of  $N_h'/\text{tors}$  over  $\mathbb{Z}/2$ . The Novikov ring  $\Lambda_\psi$  is a ring over which  $HF_*(\psi)$  can be defined, with generators given by fixed points, even if  $\psi$  is not weakly monotone. The main idea is that in some cases the field  $Q(\mathbb{Z}/2[N_h])$  injects into  $\Lambda_\psi$ , in which case we have a field extension and the ranks of the homology are the same. When we do not have an injection, we can extend  $\Lambda_\psi$  to a larger Novikov ring into which  $Q(\mathbb{Z}/2[N_h])$  does inject. When homology is computed over the larger Novikov ring, the rank can only decrease, giving the lower bound in Theorem 1.4. Yi-Jen Lee's bifurcation analysis [12; 13] is vital to this argument, giving a way to compare the Floer homology of maps with proportional fluxes. We note that Lee and Taubes [14, Corollary 6.6] have a similar Theorem for periodic Floer homology coming from their isomorphism with Seiberg-Witten Floer homology. Lee also informed us that she was independently aware of the existence of results such as Theorem 1.4.

## Organization of the paper

In Section 2 we review Floer homology and Nielsen classes; develop general twisted coefficients for Floer homology; review Novikov rings; and discuss invariance results due to Yi-Jen Lee [12; 13].

In Section 3 we give a general method for finding fixed point bounds on a monotone symplectic manifold using a Floer homology computation for any weakly monotone symplectomorphism with a particular choice of twisted coefficients.

In Section 4 we carry out this method in the case of surface symplectomorphisms to give a lower bound, using computations from [1]. We obtain an equal upper bound by explicit constructions.

In Section 5, we give fixed point bounds for surface symplectomorphisms with possibly degenerate fixed points. We use a certain cohomology operation in place of the quantum cap product, which vanishes in the situation of interest, to give cup-length-type bounds. An equal upper bound is again given by explicit constructions.

**Acknowledgements** This paper is adapted from part of my thesis [2] at UC Berkeley under Michael Hutchings, who gave invaluable advice and support. I'd also like to thank MIT for their hospitality during my last year of graduate school, and Denis Auroux, for his advising and helpful discussions. The reviewers and editors also gave numerous valuable comments and suggestions.

## 2 Floer homology, Nielsen classes, twisted coefficients, Novikov rings and bifurcation analysis

### 2.1 Review of Floer theory and monotonicity

We provide a brief summary. For a more complete discussion, see [3; 18; 1; 15].

Let  $\Sigma$  be a compact, connected, oriented surface, possibly with boundary, of negative Euler characteristic. Let  $\omega$  be a symplectic form (ie an area form) on  $\Sigma$ . Let  $\phi$  be an element of  $\text{Symp}_\partial(\Sigma, \omega)$ , the space of symplectomorphisms (ie area-preserving diffeomorphisms) with no fixed points on the boundary. We consider the mapping torus of  $\phi$ ,

$$M_\phi = \frac{\mathbb{R} \times \Sigma}{(t+1, x) \simeq (t, \phi(x))}.$$

Note that this is a  $\Sigma$ -bundle over  $S^1$  with projection  $\pi: M_\phi \rightarrow \mathbb{R}/\mathbb{Z} = S^1$ .

Let  $\Gamma(M_\phi)$  denote the space of smooth sections of  $\pi: M_\phi \rightarrow S^1$ . Note that a fixed point  $x \in \Sigma$  of  $\phi$  can be interpreted as a constant section  $\gamma_x$ . Let  $\mathcal{J}$  denote the space of almost complex structures  $J$  on  $\mathbb{R} \times M_\phi$  which are  $\mathbb{R}$ -invariant, preserve the vertical tangent bundle of  $\pi: \mathbb{R} \times M_\phi \rightarrow \mathbb{R} \times S^1$ , and for which  $\pi$  is  $(J, j)$ -holomorphic, given the standard complex structure  $j$  on the cylinder  $\mathbb{R} \times S^1$ .

Suppose  $\phi$  has nondegenerate fixed points, in the sense that  $d\phi$  does not have 1 as an eigenvalue at any fixed point. Let  $P_{x,y}\Gamma(M_\phi)$  denote the space of paths from  $\gamma_x$  to  $\gamma_y$  in  $\Gamma(M_\phi)$ . Let  $C \in \pi_0(P_{x,y}\Gamma(M_\phi))$ . Given a generic  $J \in \mathcal{J}$ , the moduli space  $\mathcal{M}(\phi, x, y, C)$  of holomorphic sections  $\mathbb{R} \times S^1 \rightarrow \mathbb{R} \times M_\phi$  in the homotopy class  $C$  is smooth and compact, of dimension  $\text{ind}(C)$ ; see [5] or [6].

For a statement of the index formula, see [16], or [1, Section 2.2] for a discussion tailored to the current setting. Other than computations that we will cite below from [1], we have need only of the change of homology class formula. In preparation, we define the cohomology class  $c_\phi \in H^2(M_\phi) = H^2(\mathbb{R} \times M_\phi)$  to be the first Chern class of the vertical tangent bundle to the projection  $\pi$ .

**Proposition 2.1** [16] *Let  $C, C' \in \pi_0(P_{x,y}\Gamma(M_\phi))$ . Then  $\text{ind}(C) - \text{ind}(C') = 2\langle c_\phi, [C - C'] \rangle$ .*

Let  $\omega_\phi$  denote the cohomology class in  $H^2(M_\phi) = H^2(\mathbb{R} \times M_\phi)$  of the vertical area form on  $M_\phi$ .

**Proposition 2.2** (Gromov compactness [6]) *Let  $I \subset \pi_0(P_{x,y}\Gamma(M_\phi))$ . The union  $\bigcup_{C \in I} \mathcal{M}(\phi, x, y, C)$  is compact if the set of values*

$$\{\omega_\phi(C - C') \mid C, C' \in \pi_0(P_{x,y}\Gamma(M_\phi))\}$$

*is bounded.*

We have the following conditions.

**Definition 2.3** A map  $\phi \in \text{Symp}_\partial(\Sigma, \omega)$  is *monotone* if  $\omega_\phi$  vanishes on the kernel of  $c_\phi$ .

**Definition 2.4** A map  $\phi \in \text{Symp}_\partial(\Sigma, \omega)$  is *weakly monotone* if  $\omega_\phi$  vanishes on  $T_0(M_\phi)$ , where  $T_0(M_\phi) \subset H_2(M_\phi; \mathbb{R})$  is generated by tori  $T$  with  $c_\phi(T) = 0$  such that  $\pi|_T: T \rightarrow S^1$  is a fibration with fiber  $S^1$ , where the map  $\pi: M_\phi \rightarrow S^1$  is the projection.

Under either of these conditions, the moduli space

$$\mathcal{M}_1(\phi, x, y) = \bigcup_{C: \text{ind}(C)=1} \mathcal{M}(\phi, x, y, C)$$

is compact. Thus we may define the symplectic Floer homology  $HF_*(\phi)$  of  $\phi$  with coefficients in  $\mathbb{Z}/2$  to be the homology of the  $\mathbb{Z}/2$ -graded chain complex  $CF(\phi) = \bigoplus_{x \in \text{Fix}(\phi)} \mathbb{Z}/2 \cdot x$  with differential

$$\partial x = \sum_y \#(\mathcal{M}(\phi, x, y)/\mathbb{R}) \cdot y,$$

where the  $\mathbb{R}$ -action is by translation in the  $\mathbb{R}$ -direction in  $\mathbb{R} \times M_\phi$ , and the  $\mathbb{Z}/2$ -grading of a fixed point  $x$  is given by the sign of  $\det(1 - d\phi)$ . The homology of this chain complex is invariant under deformations through monotone or weakly monotone maps.

We recall:

**Proposition 2.5** (monotone [18]; weakly monotone [1]) *The space of monotone (resp. weakly monotone) maps  $\phi \in \text{Symp}_\partial(\Sigma, \omega)$  is homotopy equivalent to  $\text{Diff}_\partial(\Sigma)$  under the inclusion map. In particular, the space of those in each mapping class is connected.*

## 2.2 Nielsen classes and Reidemeister trace

There is a topological separation of fixed points due to Nielsen: given a fixed point  $x$  of  $\phi$ , we obtain an element  $[\gamma_x] \in \pi_0(\Gamma(M_\phi))$ , the free homotopy class of  $\gamma_x$  in the space of sections  $\Gamma(M_\phi)$ . We denote this homotopy class by  $\Gamma(M_\phi)_{[\gamma_x]}$ . The chain complex  $CF_*(\phi)$  defined above, as well as all the variants to be defined below, split into direct summands for each Nielsen class  $\eta \in \pi_0(\Gamma(M_\phi))$ :

$$HF_*(\phi) = \sum_{\eta \in \pi_0(\Gamma(M_\phi))} HF_*(\phi, \eta).$$

We note that in the case of surfaces of negative Euler characteristic, Nielsen classes are well-defined on entire mapping classes (ie there is no monodromy). Thus the rank of  $HF_*(\phi, \eta)$  is a lower bound on the number of fixed points in the Nielsen class  $\eta$  on, for example, the weakly monotone subset of the mapping class.

A simpler lower bound on the number of nondegenerate fixed points in a Nielsen class  $\eta \in \pi_0(\Gamma(M_\phi))$  is given by the absolute value of the index of the Nielsen class

$$\text{ind}(\eta) = \sum_{x: [\gamma_x] = \eta} \text{ind}(x).$$

We note that  $\text{ind}(\eta)$  is the Euler characteristic of  $HF_*(\phi, \eta)$ . A lower bound for the number of fixed points of a map  $\psi$  with nondegenerate fixed points in the same mapping class as  $\phi$  is thus given by

$$\sum_{\eta \in \pi_0(\Gamma(M_\phi))} |\text{ind}(\eta)|.$$

For maps with possibly degenerate fixed points, the bound from Nielsen theory is the number of *essential* Nielsen classes; that is, the number of Nielsen classes  $\eta$  for which  $\text{ind}(\eta) \neq 0$ .

## 2.3 Twisted coefficients

We have a groupoid  $\mathcal{G}_\phi$  whose objects are sections of the mapping torus  $M_\phi$  and whose morphisms from  $x$  to  $y$  are given by homotopy classes of paths from  $x$  to  $y$

in  $\Gamma(M_\phi)$ . Given a ring  $R$ , we can take the groupoid algebroid  $R\langle\mathcal{G}_\phi\rangle$ , a category enriched over  $R$ -modules with the same objects as  $\mathcal{G}_\phi$  and with  $\text{Hom}_{R\langle\mathcal{G}_\phi\rangle}(x, y)$  given by the free  $R$ -module generated by elements of  $\text{Hom}_{\mathcal{G}_\phi}(x, y)$ . Note that we have a homomorphism  $\text{ind}: \mathcal{G}_\phi \rightarrow \mathbb{Z}$  given by the index.

If we have a representation  $\rho$  from  $R\langle\mathcal{G}_\phi\rangle$  to an  $R$ -module  $M$ , we can define *Floer homology with coefficients in  $\rho$*  (or  $M$  if  $\rho$  is understood) as the homology of a chain complex over  $M$  with generators the fixed points of  $\phi$  and differential given by

$$\partial x = \sum_y \sum_{C \in \mathcal{M}_1(x, y)} \rho([C]) \cdot y,$$

where  $[C]$  is the homotopy class of the path in  $\Gamma(M_\phi)$  associated to the flow line  $C$ , and we abuse notation by identifying  $y$  with the section  $\gamma_y \in \Gamma(M_\phi)$ . This is defined for weakly monotone  $\phi$  for arbitrary  $\rho$  (because then  $\mathcal{M}_1(\phi, x, y)$  is compact). In Section 2.4 we discuss representations  $\Lambda_\phi$  suitable for each  $\phi$ .

We will typically suppress the ring  $R$ , which throughout this paper may be assumed to be  $\mathbb{Z}/2$ .

The *standard representation*  $\rho_{\text{st}}$  into the group ring of  $H_1(\Gamma(M_\phi))$  is defined as follows. For every pair of sections  $x, y$  and every index  $i$ , we choose a path  $C_{x, y}^i$  in  $\Gamma(M_\phi)$  between them, of index  $i$  if possible. We require that

$$C_{x, y}^i \cdot C_{y, z}^j \simeq C_{x, z}^{i+j}, \quad C_{x, y}^i = -C_{y, x}^{-i} \quad \text{and} \quad C_{x, x}^0 = *.$$

Here  $\cdot$  signifies appending paths,  $-$  signifies reversal of a path, and  $*$  signifies the constant path. Then  $\rho_{\text{st}}([C])$ , for  $C$  a path from  $x$  to  $y$ , is defined to be  $[C \cdot C_{y, x}^{-\text{ind}(C)}] \in H_1(\Gamma(M_\phi))$ . Note that in fact this lies in  $\ker(c_\phi) \subset H_1(\Gamma(M_\phi))$ . We have made choices, but the resulting Floer homology is well-defined up to a change of basis.

We typically compose this with the map  $H_1(\Gamma(M_\phi)) \rightarrow H_2(M_\phi)$  to get what we call *fully twisted coefficients*, over  $\mathbb{Z}/2[H_2(M_\phi)]$ . If we desire to have field coefficients, we may for example take the quotient field of the group ring of  $H_2(M_\phi)/\text{tors}$ .

## 2.4 Novikov rings

**Definition 2.6** For  $R$  a ring,  $G$  an abelian group and  $N: G \rightarrow \mathbb{R}$  a homomorphism, the *Novikov ring*  $\text{Nov}_R(G, N)$  is defined to be the ring whose elements are formal sums  $\sum_{g \in G} a_g \cdot g$ , where  $a_g \in R$  are such that for each  $r \in \mathbb{R}$ , only finitely many of the  $a_g$  with  $N(g) < r$  are nonzero.

There is also the universal Novikov ring:

**Definition 2.7** For  $R$  a ring, the *universal Novikov ring*  $\Lambda_R$  is defined to be the ring whose elements are formal sums  $\sum_{r \in \mathbb{R}} a_r \cdot T^r$ , where  $a_r \in R$  are such that, for each  $s \in \mathbb{R}$ , only finitely many of the  $a_r$  with  $r < s$  are nonzero.

Note that this is a field if  $R$  is a field. We have maps  $\text{Nov}_R(G, N) \rightarrow \Lambda_R$  given by  $g \mapsto T^{N(g)}$ . If  $R$  is a field and  $N$  is injective, this is an extension of fields.

We define a representation, the *natural Novikov coefficients for  $\phi$* , denoted by  $\Lambda_\phi$ , as follows. We have a representation into  $\text{Nov}_{\mathbb{Z}/2}(\ker(c_\phi), \omega_\phi)$ , where the maps  $c_\phi, \omega_\phi: H_1(\Gamma(M_\phi)) \rightarrow \mathbb{R}$  are defined as in Section 2.1. The representation is defined in the same manner as the standard representation; we have simply taken a submodule  $\ker(c_\phi) \subset H_1(\Gamma(M_\phi))$  in which the image must lie, and allowed certain infinite sums. We further compose this with the map to  $\Lambda_{\mathbb{Z}/2}$ . This all is simply to say we take

$$\Lambda_\rho([C]) = T^{\omega_\phi(C \cdot C_{y,x}^{-\text{ind}(C)})}.$$

We may define  $HF_*(\phi, \Lambda_\phi)$ , the Floer homology of  $\phi$  with coefficients in  $\Lambda_\phi$  for any  $\phi$ . The point is simply that, while we may not have finiteness for  $\mathcal{M}_1(x, y)$ , we do have that there are only finitely many  $C \in \mathcal{M}_1(x, y)$  with  $\omega_\phi(C) < r$  for any given  $r \in \mathbb{R}$ , by Gromov compactness, and this is precisely what is required.

### 2.5 Bifurcation analysis of Yi-Jen Lee

Yi-Jen Lee [12; 13] has worked out a general bifurcation argument for what she calls Floer-type theories. Michael Usher [21] has a nice summary of the invariance result this gives (which Lee conjectured in an earlier paper [11, equation 3.2] but did not explicitly state as a theorem in [12; 13]) and its algebraic aspects. We have adapted the statement to our setting involving representations  $\rho$  of  $\mathbb{Z}/2\langle \mathcal{G}_\phi \rangle$ .

**Theorem 2.8** ([21, Theorem 3.6], due to Lee [12; 13]) *Suppose  $(X, \omega)$  is a symplectic manifold with  $\pi_2(X) = 0$ . Let  $\phi_r: X \rightarrow X$  be a smooth family of symplectomorphisms with  $r \in \mathbb{R}$  and  $J_r = \{J_t\}_r$  with  $t \in \mathbb{R}$  a smooth family (of 1-periodic families) of almost complex structures on  $X$  such that  $(\phi_0, J_0)$  and  $(\phi_1, J_1)$  are generic. Let  $N = \ker(c_\phi): H_1(\Gamma(M_{\phi_r})_\eta) \rightarrow \mathbb{R}$  (this is independent of  $r$ ).*

- (i) *Suppose  $\omega_{\phi_r}|_N = f(r)\omega_{\phi_0}|_N$ , for  $f(r) \in \mathbb{R}$ . Then  $HF_*(\phi_0, \eta, J_0; \Lambda_{\phi_0}) \cong HF_*(\phi_1, \eta, J_1; \Lambda_{\phi_0})$ . □*
- (ii) *Suppose  $\omega_{\phi_r}|_N = 0$  for all  $r$ . Then  $HF_*(\phi_0, \eta, J_0) \cong HF_*(\phi_1, \eta, J_1)$ . In fact,  $HF_*(\phi_0, \eta, J_0; \rho) \cong HF_*(\phi_1, \eta, J_1; \rho)$  for any representation  $\rho$ .*

We point out that in item (i) we are indeed taking the Floer homology of  $\phi_1$  with coefficients given by the representation  $\Lambda_{\phi_0}$ . What this means is that we use  $\omega_{\phi_0}$  to determine the power of  $T$  in  $\rho([C])$ .

### 3 Bounds on fixed points in symplectic mapping classes

#### 3.1 Representations and flux

Throughout this section consider  $(X, \omega)$  a monotone symplectic manifold. The goal of this section is to give a lower bound on fixed points for symplectomorphisms in a symplectic mapping class  $h \in \pi_0(\text{Symp}(X, \omega))$  in terms of the rank of  $HF_*(\phi, \rho)$  for one suitable choice of a pair  $(\phi, \rho)$  with  $\phi \in h$  and  $\rho$  a representation of  $\mathbb{Z}/2(\mathcal{G}_\phi)$ . In this subsection we define the representations  $\rho_m$  for which it will be shown that  $(\phi, \rho_m)$  is such a pair for any monotone  $\phi$ , and  $\rho_{wm}$  for which it will be shown that  $(\phi, \rho_{wm})$  is such a pair for any weakly monotone  $\phi$ .

**Monotone case** We have a representation  $\rho_m$  that works for any monotone  $\phi$ . The representation  $\rho_m$  is defined as follows:

We have the representation  $\rho_{st}$  into  $\mathbb{Z}/2[H_1(\Gamma(M_\phi))]$ . We first compose<sup>7</sup> with the map  $H_1(\Gamma(M_\phi)) \rightarrow H_2(M_\phi)$ , noting that the image lies in the kernel of  $c_\phi: H_2(M_\phi) \rightarrow \mathbb{R}$ . Now we compose with the map to  $H_1(X)$  in the long exact sequence for the mapping torus, a part of which is

$$(1) \quad H_2(X) \xrightarrow{i} H_2(M_\phi) \xrightarrow{\partial} \ker(\phi_* - \text{id}) \subset H_1(X).$$

We denote the image of  $\ker(c_\phi)$  in  $H_1(X)$  by  $N_h$  (this depends only on the mapping class  $h$ ). Finally, we mod out by torsion and then take the quotient field, so that our coefficients lie in the field

$$Q(\mathbb{Z}/2[N_h/\text{tors}]),$$

where  $Q$  denotes taking the quotient field. Essentially we have taken fully twisted field coefficients, but we have been careful about where the image lies so that we can define flux in this context, which both will be useful in specifying which maps  $\phi$  are suitable to work with and will be a useful tool in what is to come.

<sup>7</sup>Technically we are composing with the map induced on the group ring by this map on homology. We continue this abuse of terminology in what follows.

We have a characterization of monotone maps in terms of Flux, which we define using the long exact sequence (1) above:

**Definition–Lemma 3.1** *The flux of any symplectomorphism  $\phi$ , denoted by*

$$\text{Flux}(\phi): N_h/\text{tors} \rightarrow \mathbb{R}$$

*and defined as*

$$\text{Flux}(\phi)(\gamma) = \omega_\phi(C_\gamma),$$

where  $C_\gamma \in H_2(M_\phi)$  is such that  $\partial(C_\gamma) = \gamma$  and  $c_\phi(C_\gamma) = 0$ , is well-defined. Here  $\partial$  is the map from the long exact sequence (1).

**Proof** First, we note that such a  $C_\gamma$  exists because  $N_h$  is the image under  $\partial$  (in the long exact sequence) of  $\ker(c_\phi)$ . Next we note that  $\omega_\phi(C_\gamma)$  is well-defined because if we take any other  $C'_\gamma$  such that  $\partial(C'_\gamma) = \gamma$  and  $c_\phi(C'_\gamma) = 0$ , the difference  $C_\gamma - C'_\gamma$  is in the kernel of  $c_\phi$  and, being in the kernel of  $\partial$ , must also come from an element of  $H_2(X)$ , which we denote by  $B$ . We have that  $c_\phi \circ i: H_2(X) \rightarrow \mathbb{Z}$  agrees with  $c_1(X): H_2(X) \rightarrow \mathbb{Z}$ . Thus  $c_1(X)(B) = 0$ . By monotonicity of  $X$ , this implies that  $\omega(B) = 0$ . Because  $\omega_\phi \circ i: H_2(X) \rightarrow \mathbb{R}$  agrees with  $\omega: H_2(X) \rightarrow \mathbb{R}$  as well, we conclude that  $\omega_\phi(C_\gamma) - \omega_\phi(C'_\gamma) = 0$ . Finally, we remark that this is a homomorphism, and thus any torsion in  $N_h$  must map to  $0 \in \mathbb{R}$ . □

**Lemma 3.2** *For a symplectomorphism  $\phi$ , we have*

$$\phi \text{ is monotone} \iff \text{Flux}(\phi) = 0.$$

**Proof** The statement  $\text{Flux}(\phi) = 0$  is equivalent to  $\omega_\phi$  vanishing on the kernel of  $c_\phi$ . This implies that  $\omega_\phi$  is some multiple of  $c_\phi$ . □

**Weakly monotone case** With  $(X, \omega)$  monotone, we also give a representation  $\rho_{\text{wm}}$  that works for any weakly monotone  $\phi$ . The representation  $\rho_{\text{wm}}$  is defined as follows:

Let the image of the map  $H_1(\Gamma(M_\phi)) \rightarrow H_2(M_\phi)$  be denoted by  $T(M_\phi)$ . This is generated by 2–tori in  $M_\phi$  standardly fibering over  $S^1$ . When composing the standard representation into  $\mathbb{Z}/2[H_1(\Gamma(M_\phi))]$  with the map  $H_1(\Gamma(M_\phi)) \rightarrow H_2(M_\phi)$ , the image thus lies not only in  $\ker(c_\phi)$  but in  $\ker(c_\phi|_{T(M_\phi)})$ . In fact it lies moreover in  $T_0(M_\phi)$ , generated by 2–tori  $T$  in  $M_\phi$  standardly fibering over  $S^1$  such that  $c_\phi(T) = 0$ . We denote the image of  $T_0(M_\phi)$  under  $\partial$  in the long exact sequence as

$$N'_h \subset N_h \subset \ker(\phi_* - \text{id}) \subset H_1(X).$$



As before, we mod out by torsion and then take the quotient field, so our coefficients lie in the field

$$Q(\mathbb{Z}/2[N'_h/\text{tors}]).$$

We restrict  $\text{Flux}(\phi)$  to  $N'_h/\text{tors} \subset N_h/\text{tors}$ .

**Lemma 3.3** For a symplectomorphism  $\phi$ , we have

$$\phi \text{ is weakly monotone Nielsen class } \eta \iff \text{Flux}(\phi)|_{N'_h/\text{tors}} = 0.$$

**Proof** The statement  $\text{Flux}(\phi)|_{N'_h/\text{tors}} = 0$  is equivalent to  $\omega_\phi$  vanishing on  $T_0(M_\phi)$ . Let  $T_0(M_\phi)_\eta$  be generated by 2-tori  $T$  in  $M_\phi$  standardly fibering over  $S^1$  such that  $c_\phi(T) = 0$  and which moreover have a section in Nielsen class  $\eta$ . Then the vanishing of  $\omega_\phi$  on  $T_0(M_\phi)$  is equivalent to  $\omega_\phi$  vanishing on  $T_0(M_\phi)_\eta$  for every  $\eta$ , because every such torus has a section, which lies in some Nielsen class, ie component of  $\Gamma(M_\phi)$ .  $\square$

**Corollary 3.4** The space  $\text{Symp}_h^{\text{wm}}(X, \omega)$  of maps in the mapping class  $h$  which are weakly monotone Nielsen class  $\eta$  is homotopy equivalent under the inclusion to  $\text{Symp}_h(X, \omega)$ .  $\square$

### 3.2 Fixed point bounds

**Theorem 3.5** Let  $(X, \omega)$  be a monotone symplectic manifold,  $h$  a symplectic mapping class on  $X$ , and  $\phi \in h$ . Let  $\phi$  be such that  $\text{Flux}(\phi)|_{N'_h} = 0$ . Then the rank of

$$HF_*(\phi; Q(\mathbb{Z}/2[N'_h/\text{tors}]))$$

gives a lower bound on the rank  $HF_*(\psi; \Lambda_\psi)$  for  $\psi$  any map in the class  $h$ .

**Corollary 3.6** Let  $X$  be a monotone symplectic manifold,  $h$  a symplectic mapping class on  $X$ , and  $\phi \in h$ . Let  $\phi$  be such that  $\text{Flux}(\phi)|_{N'_h} = 0$ . Then the rank of

$$HF_*(\phi; Q(\mathbb{Z}/2[N'_h/\text{tors}]))$$

gives a lower bound on the number of fixed points of any map in the mapping class with nondegenerate fixed points.  $\square$

**Remark 3.7** The corresponding versions with  $\phi$  such that  $\text{Flux}(\phi) = 0$  and coefficients in  $Q(\mathbb{Z}/2[N_h/\text{tors}])$  also hold, either with the same proofs or as a formal consequence.

Theorem 3.5 follows from the following three lemmas.

**Lemma 3.8** *Let  $\phi \in h$  be such that  $\text{Flux}(\phi)|_{N'_h} = 0$  and let  $\psi \in h$ . Then  $HF(\psi, \Lambda_\psi) \cong HF(\phi, \Lambda_\psi)$ .*

**Proof** We use (i) from Theorem 2.8. Consider a smooth family  $\psi_r$  of symplectomorphisms from  $\psi_0 = \psi$  to  $\psi_1 = \phi$  with  $\text{Flux}(\psi_r)|_{N'_h} = (1 - r)\text{Flux}(\psi)|_{N'_h}$ . Note that such a family exists as we can modify Flux in any direction we desire by flowing by an  $S^1$ -valued Hamiltonian representing, as a map to  $S^1$ , the desired cohomology class of the modification. Then (for a generic family of almost complex structures) the conditions of (i) in Theorem 2.8 are met with  $f(r) = 1 - r$ . Summing over Nielsen classes gives the result. □

**Lemma 3.9** *With  $\phi$  and  $\psi$  as above, the rank of  $HF(\phi, \Lambda_\psi)$  equals the rank of*

$$HF(\phi, Q(\mathbb{Z}/2[N'_h/\text{tors}])/\ker(\text{Flux}(\psi)|_{N'_h})).$$

**Proof** We have field extensions

$$\begin{aligned} Q(\mathbb{Z}/2[N'_h/\text{tors}])/\ker(\text{Flux}(\psi)|_{N'_h}) \\ \hookrightarrow \text{Nov}_{\mathbb{Z}/2}(N'_h/\text{tors}/\ker(\text{Flux}(\psi)|_{N'_h}), \text{Flux}(\psi)|_{N'_h}) \hookrightarrow \Lambda_\psi. \end{aligned}$$

The first is by allowing some infinite sums, and the second is the map discussed in Section 2.4. Field extensions are flat, so the ranks are equal. □

**Lemma 3.10** (Vân, Ono and Lê [22, Appendix C]) *Let  $k$  be a field and let  $C_*$  be a chain complex over  $k_n := k[t_1, \dots, t_n]$ . Consider  $k_n$  as an augmented  $k_m$ -algebra (for some  $0 < m < n$ ) with augmentation sending  $t_i$  to  $t_i$  for  $i \leq m$  and  $t_i$  to 1 for  $i > m$ . Then*

$$\text{rank } H_*(C_* \otimes_{k_n} k_m) \leq \text{rank } H_*(C_*). \quad \square$$

**Proof of Theorem 3.5** Lemma 3.8 implies that, in particular, the rank of  $HF(\psi, \Lambda_\psi)$  equals the rank of  $HF(\phi, \Lambda_\psi)$ . By Lemma 3.9, this rank is equal to the rank of  $HF(\phi, Q(\mathbb{Z}/2[N'_h/\text{tors}])/\ker(\text{Flux}(\psi)|_{N'_h}))$ . We note that

$$\begin{aligned} CF(\phi, Q(\mathbb{Z}/2[N'_h/\text{tors}])/\ker(\text{Flux}(\psi)|_{N'_h})) \\ \simeq CF(\phi, Q(\mathbb{Z}/2[N'_h/\text{tors}])) \otimes_{Q(\mathbb{Z}/2[N'_h/\text{tors}])} Q(\mathbb{Z}/2[N'_h/\text{tors}])/\ker(\text{Flux}(\psi)|_{N'_h}), \end{aligned}$$

with the augmentation map sending elements of the kernel of  $\text{Flux}(\psi)|_{N'_h}$  to one. The spaces  $Q(\mathbb{Z}/2[N'_h/\text{tors}])$  and  $Q(\mathbb{Z}/2[N'_h/\text{tors}])/\ker(\text{Flux}(\psi)|_{N'_h})$  are vector spaces

over  $\mathbb{Q}$  and as such their group rings over  $\mathbb{Z}/2$  and the aforementioned augmentation map are as in Lemma 3.10, where  $n$  and  $m$  are their respective dimensions, with  $k = \mathbb{Z}/2$ . Thus, by Lemma 3.10, the rank of the homology of the displayed complexes is less than or equal to the rank of  $HF(\phi, \mathbb{Z}/2[N'_h/\text{tors}])$ , which is the same as the rank of  $HF(\phi, Q(\mathbb{Z}/2[N'_h/\text{tors}]))$ , giving the result.  $\square$

## 4 Bounds on fixed points for surface symplectomorphisms

### 4.1 Standard form maps and Nielsen classes

In this section we describe standard form maps and their Nielsen classes. See also [1, Sections 3–4], which has more background.

#### 4.1.1 Standard form for geometric components

**Definition 4.1** For the identity mapping class, a standard form map is a small perturbation of the identity map by the Hamiltonian flow associated to a Morse function for which the boundary components are locally minima and maxima.

In this case every fixed point is in the same Nielsen class. This Nielsen class has index given by the Euler characteristic of the surface.

**Definition 4.2** For nonidentity periodic mapping classes, a standard form map is an isometry with respect to a hyperbolic structure on the surface with geodesic boundary.

Every fixed point is in a separate Nielsen class and each of the Nielsen classes for which there is a fixed point has index one.

**Definition 4.3** For a pseudo-Anosov mapping classes, a standard form map is a (specified) symplectic smoothing of the singularities and boundary components of the standard singular representative. Each singularity has a number  $p \geq 3$  of prongs, and each boundary component has a number  $p \geq 1$  of prongs. If a singularity or boundary component is (setwise) fixed, it has some relative fractional twist coefficient in  $\mathbb{Q}/\mathbb{Z}$  with denominator  $p$ .

See [1, Section 3.2] for further details, including an introduction to pseudo-Anosov maps. For the specified smoothing, see [1, Figure 3 and surrounding]. See also the top images in Figure 1 for a rendition in an example.

There is a separate Nielsen class for every smooth fixed point, which is of index one or minus one; for every fixed singularity, which when symplectically smoothed gives

$p - 1$  fixed points all of index minus one if the rotation number is zero modulo  $p$ , or one fixed point of index one otherwise [1]; and for every fixed boundary component with rotation number zero modulo  $p$ , which when symplectically smoothed gives  $p$  fixed points all of index minus one.

In the pseudo-Anosov case, note that what we are using as a boundary is a deformation of a punctured singularity in terms of the standard singular representative.

**Remark 4.4** From this discussion, we see that for nonidentity periodic and pseudo-Anosov mapping classes, the standard form map is such that all fixed points are nondegenerate and, for every Nielsen class  $\eta$ , the number of fixed points in  $\eta$  is  $|\text{ind}(\eta)|$ .

**4.1.2 Standard form for reducible maps and fixed annuli** In addition to the geometric components described above, we extend the notion of *components* to allow for a number of *fixed annuli* between geometric components or near a boundary when there is sufficient twisting along the reducing curve or at a boundary curve.

To obtain a standard form for reducible mapping classes, the standard forms for geometric components, described above, are joined by twisting regions (à la Dehn twists). Each twisting region may have any number (in  $\mathbb{Z}_{\geq 0}$ ) of circles of fixed points, which we think of as fattened to annuli and consider as *fixed annuli*. Formally we have a standard form whose existence follows from Thurston’s classification [20; 4]; see also [1, Definition 4.6].

**Definition 4.5** A reducible map  $\phi$  is in *standard form* if there is a  $\phi$ - and  $\phi^{-1}$ -invariant finite union of disjoint noncontractible (closed) annuli  $N \subset \Sigma$  such that:

- (i) For  $A$  a component of  $N$  and  $\ell$  the smallest positive integer such that  $\phi^\ell$  maps  $A$  to itself, the map  $\phi^\ell|_A$  is either a *twist map* or a *flip-twist map*. That is, with respect to coordinates  $(q, p) \in [0, 1] \times \mathbb{R}/\mathbb{Z}$ , we have one of

$$\begin{aligned} (q, p) &\mapsto (q, p - f(q)) && \text{(twist map),} \\ (q, p) &\mapsto (1 - q, -p + f(q)) && \text{(flip-twist map),} \end{aligned}$$

where  $f : [0, 1] \rightarrow \mathbb{R}$  is a strictly monotonic smooth map. We call the (flip-) twist map *positive* or *negative* if  $f$  is increasing or decreasing, respectively. Note that these maps are area-preserving.

- (ii) Let  $A$  and  $\ell$  be as in (i). If  $\ell = 1$  and  $\phi|_N$  is a twist map, then  $\text{Im}(f) \subset [0, 1]$ . That is,  $\phi|_{\text{int}(A)}$  has no fixed points. (If we are to twist multiple times, we

separate the twisting region into the parallel *fixed annuli* separated by regions on which the map is the identity.) We further require that parallel twisting regions twist in the same direction.

- (iii) For  $S$  a component of  $\Sigma \setminus N$  and  $\ell$  the smallest integer such that  $\phi^\ell$  maps  $A$  to itself, the map  $\phi^\ell|_S$  is area-preserving and is either isotopic to the *identity*, *periodic*, or *pseudo-Anosov*. In these cases, we require the map to be in standard form as above.

We are most interested in the *fixed annuli* defined in item (ii) and which are parallel and interstitial to the twist regions, as that is where fixed points may occur.

**4.1.3 Counting fixed annuli** The fixed annuli described above can be counted in terms of a variant of fractional Dehn twist coefficients, related to those in [7]. This subsection is optional, as the arguments proceed from the definition of fixed annuli in the preceding subsection, but may be of interest. We first discuss fractional twist coefficients, and then how to use that to count the number of fixed annuli.

**Relative fractional twist coefficient** Consider a mapping class  $g$  with a *reducing* (setwise-fixed non-nullhomotopic, non-boundary-parallel) curve  $C$  or a setwise-fixed boundary  $C$ . Suppose the induced map on the homology of  $C$  is the identity (rather than  $-1$ ). Then for each component abutting  $C$ , a geometric (periodic or pseudo-Anosov) representative of that component gives a *relative fractional twist coefficient* in  $\mathbb{Q}/\mathbb{Z}$  at its boundary. In the periodic case, this is simply the fraction by which it rotates its circle boundary. In the pseudo-Anosov case, the singular measured foliations have  $p$  prongs arranged around  $C$  and these are permuted, which we interpret as a rational rotation.

**Number of fixed annuli: reducing curve case** Across such a reducing curve  $C$ , relative to the geometric representatives on each side, we obtain a total fractional Dehn twist coefficient  $x \in \mathbb{Q}$  at  $C$ , which is a lift of the sum of the two relative fractional twist coefficients. Obtain these lifts by isotoping the map to pointwise fix  $C$  and using the fractional Dehn twist coefficient [7] from each side. (Such isotopies are related by a free  $\mathbb{Z}$ -action which adjusts the coefficients on each side in complementary fashion.)

We say the mapping class  $g$  has a *fixed annulus* parallel to the reducing curve  $C$  for each (necessary) more-than-full twist. That is, we say  $g$  has  $\text{ceil}(|x| - 1)$  fixed annuli parallel to  $C$ .

**Number of fixed annuli: boundary curve case** In the case of a setwise-fixed boundary curve  $C$ , we are considering the mapping class  $g$ , which is an element of  $\pi_0$  of the space of maps in  $\text{Diff}_0^+(\Sigma)$ , which fix no points on the boundary. There are then two neighboring mapping classes  $g_1, g_2$  in  $\pi_0$  of the space of maps  $\text{Diff}^+(\Sigma, \partial\Sigma)$  which fix pointwise the boundary. Each of these has its own fractional Dehn twist coefficient [7], which we denote by  $y_1, y_2 \in \mathbb{Q}$  respectively; these necessarily differ by 1. We may think of the total twisting for  $g$  at  $C$  as being allowed to take any value in the open interval between  $y_1$  and  $y_2$ .

Again, for each (necessary) more-than-full twist at  $C$  we say the mapping class  $g$  has a *fixed annulus* parallel to the boundary curve  $C$ . That is the minimum over the possible total twisting values, ie over the values in the open interval between  $y_1$  and  $y_2$ , of the number of more-than-full twists. More simply, this is the minimum (over  $i = 1, 2$ ) of  $\text{floor}(|y_i|)$ .

**4.1.4 Fixed points of standard form maps** The fixed points of our standard form reducible maps are as follows:

- **Type Ia** The entire component of components  $S$  of  $\Sigma \setminus N$  on which the induced map is the identity, with  $\chi(S) < 0$ .
- **Type Ib** The entire component of components  $S$  of  $\Sigma \setminus N$  on which the induced map is the identity, with  $\chi(S) = 0$ . These are annuli and only occur when we have multiple parallel Dehn twists.
- **Type IIa** Fixed points  $x$  of periodic components  $S$  of  $\Sigma \setminus N$  with  $\chi(S) < 0$  which are setwise fixed by  $\phi$ . These are each index one.
- **Type IIb** Fixed points  $x$  of flip-twist regions. These are each index one. Note that each flip-twist region has two fixed points.
- **Type III** Fixed points  $x$  of pseudo-Anosov components  $S$  of  $\Sigma \setminus N$  which are setwise fixed by  $\phi$ . These come in 4 types (note that there are no fixed points associated to a rotated puncture):
  - **Type IIIa** Fixed points which are not associated with any singularity or boundary component of the pre-smoothed map. These are index one or negative one.
  - **Type IIIb- $p$**  Fixed points which come from an unrotated singular point with  $p$  prongs. There are  $p - 1$  of these for each such singular point, each of index negative one.

- **Type IIIc** Fixed points which come from a rotated singular point. These are each of index one.
- **Type IIId- $p$**  Fixed points which come from an unrotated boundary component with  $p$  prongs. There are  $p$  for each such boundary component, each of index negative one.

**4.1.5 Nielsen classes of fixed points of standard form maps** We review Nielsen classes of fixed points of standard form reducible maps, as discussed in [1].

In [1], adapting the work of [10] to the area-preserving case, we showed that we have a separate Nielsen class for every component of type Ia or type Ib, for every single fixed point of type IIa, IIb, IIIa, or IIIc, and for every unrotated singular point of the pre-smoothed map for type IIIb (ie the collection of fixed points associated to a single unrotated singular point are all in the same Nielsen class).

Type IIId fixed points associated to the same boundary component are in the same Nielsen class. They may also be in the same Nielsen class as fixed points of the component they abut if that component has fixed points at that boundary also of type IIId or of type Ia (they cannot abut regions of with type Ib fixed points). In the former case this Nielsen class is again separate from all others already specified, and has combined index  $-p - q$  from the  $p + q$  index negative one fixed points. In the latter case, we have already stated that this Nielsen class is separate from all others already specified. Thus we have:

**Lemma 4.6** *The combined index of the Nielsen class  $\eta$  associated to a fixed component of  $S$  is*

$$\text{ind}(\eta) = \chi(S) - \sum_{\substack{C \in \pi_0(\partial S) \\ \text{component abutting at } C \text{ is of type IIId-}p}} p. \quad \square$$

Finally, the index of a fixed component of type Ib is zero.

**4.2 Floer homology with twisted coefficients**

We compute the Floer homology  $HF_*(\phi, Q(\mathbb{Z}/2[N'_h/\text{tors}]))$  for  $\phi$  a standard form reducible map. This splits into a direct sum over Nielsen classes. For Nielsen classes not associated to a fixed component,  $\phi$  has fixed points all of the same index and thus there are no flow-lines at all and the differential vanishes.

Consider first components  $S$  on which the induced map is the identity, possibly abutting components at a boundary with type IIIId fixed points of pseudo-Anosovs. We perturb with the Hamiltonian flow of a small Morse–Smale function that patches together with the perturbation of the function on a neighborhood of any boundary components with type IIIId fixed points. This is given by a Hamiltonian flow of a Morse–Smale function with  $p$  saddle points; see [1] for details. In [1] we showed that the flow-lines we get between fixed points in the Nielsen class  $\eta$  corresponding to the fixed points in this component are only those which correspond to Morse flow-lines.

We are interested in the rank of the summand of  $HF_*(\phi, Q(\mathbb{Z}/2[N'_h/\text{tors}]))$  corresponding to such a Nielsen class  $\eta$ . The key is to understand the extrema of the Morse–Smale function. If the component has boundaries which rotate in opposite directions, we may choose the Morse–Smale function to have no extrema, and then there are  $|\text{ind}(\eta)|$  fixed points in the Nielsen class all of the same index and thus no flow-lines. If the component has boundaries rotating all in the same direction, we may choose a Morse–Smale function with one extremum. There are  $|\text{ind}(\eta)| + 2$  fixed points in the Nielsen class  $\eta$ . Finally, if there is no boundary, we may choose a Morse–Smale function with two extrema. There are  $|\text{ind}(\eta)| + 4$  fixed points in the Nielsen class  $\eta$ . In these latter two cases, we must further understand the flow-lines.

We consider the one-boundary-component case first. For the purposes of computing rank, we may assume the extremum is a minimum by duality. Suppose first that we have a type IIIId boundary component abutting our fixed component  $S$ . In [1] we show that there is precisely one flow-line from each of the  $p$  type IIIId fixed points to the minimum; see Figure 1. In this case we have a cancellation because we are working with field coefficients and whatever element (even zero) of  $N'_h/\text{tors}$  this flow-line corresponds to under the representation  $\rho_{\text{wm}}$ , it corresponds to a nonzero and thus invertible element of  $Q(\mathbb{Z}/2[N'_h/\text{tors}])$ . Thus the rank of the summand corresponding to the Nielsen class  $\eta$  is  $|\text{ind}(\eta)|$ .

Suppose next that  $S$  does not abut any type IIIId boundary components. Denote the minimum by  $y$ . Then for every saddle point  $x$  we have two flow-lines to  $y$ .

**Lemma 4.7** *We have that  $\partial x = a_x y$ , where  $a_x$  is nonzero if and only if the class of the closure of the descending manifold of  $x$  in  $N'_h/\text{tors} \subset H_1(\Sigma)$  is nonzero.*

**Proof** See Figure 2. We have two flow-lines  $C_1$  and  $C_2$ . Thus

$$\partial x = \rho([C_1 \cdot C_{y,x}^{-1}])y + \rho([C_2 \cdot C_{y,x}^{-1}])y = a \cdot y - b \cdot y.$$



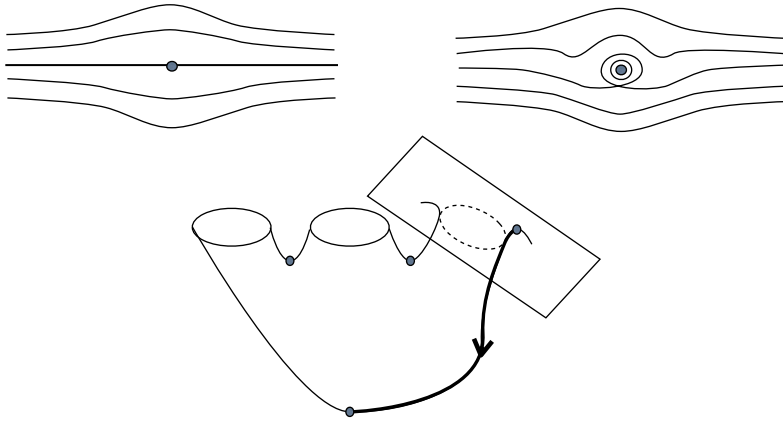

Figure 1: Top left: level sets of a Morse–Smale function for a neighborhood of an unperturbed III d boundary, viewed as a puncture. Top right: level sets of the perturbed Morse–Smale function. Note that the central disk, which rotates under the Hamiltonian flow, is excised to glue with other components. Bottom: the plane represents part of the pseudo-Anosov with type III d boundary. The remainder of the surface represents a component with type Ia fixed points. The unique flow-line is shown in bold.

Here, considered as elements of the group ring, the values  $a, b \in N'_h/\text{tors}$  are such that  $a - b$  in  $N'_h/\text{tors}$  is the class of the descending manifold of  $x$ . This value is zero if and only if  $a = b$ . The result follows.  $\square$

If  $a_x \neq 0$  for some  $x$ , then  $y$  is a boundary because our coefficients lie in a field, and so we have a cancellation and the rank is only  $|\text{ind}(\eta)|$ . If  $a_x = 0$  for all  $x$ , this is the statement that the differential vanishes in the summand corresponding to the Nielsen class  $\eta$ , and so the rank is  $|\text{ind}(\eta)| + 2$ .

**Lemma 4.8** *In the above situation,  $a_x = 0$  for every saddle point  $x$  if and only if  $S$  has genus zero and every boundary component of  $S$  is nullhomologous in  $H_1(\Sigma, \partial\Sigma)$ .*

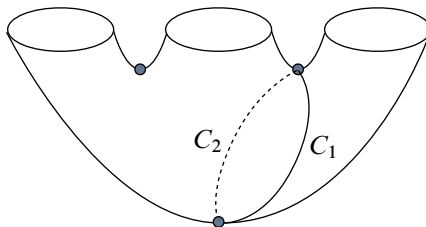

Figure 2: The closure of the descending manifold.

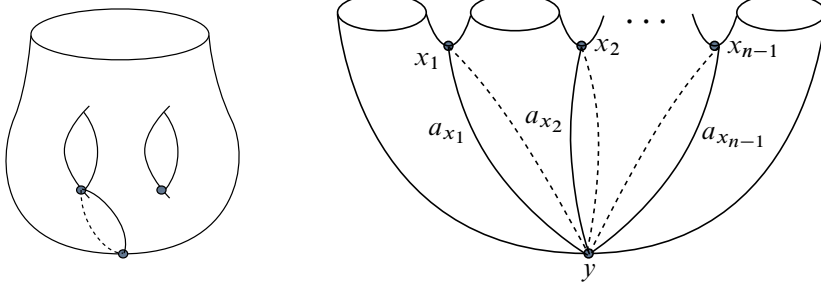

Figure 3: Left: the nonzero genus case. Right: the genus zero case with all boundary components rotating the same direction.

**Proof** In the case in which  $S$  has genus, we can find two descending manifolds which meet algebraically once. It follows that neither of them are nullhomologous. See Figure 3, left.

If  $S$  is genus zero, it appears as in Figure 3, right. The homology class of each of the boundary components is given by either (plus or minus) the homology class of one of the descending manifolds (if on either end) or the difference of two such. We see all the descending manifolds are nullhomologous if and only if all of the boundary components are. □

In the case in which  $S$  has no boundary, we see that  $a_x$  is never zero for saddle points  $x$  and thus we cancel the minimum. Dually, we also cancel the maximum, say with any saddle point we haven't used to cancel the minimum. Thus in this case the rank is  $|\text{ind}(\eta)|$ . Summing up, we have shown:

**Proposition 4.9** *Consider a Nielsen class  $\eta$  corresponding to a fixed component  $S$ . If  $S$  does not abut any type IIIId boundary components, every boundary component rotates in the same direction,  $S$  has genus zero, and every boundary component of  $S$  is nullhomologous in  $H_1(\Sigma, \partial\Sigma)$ , then the rank of the summand of  $HF_*(\phi, Q(\mathbb{Z}/2[N'_h/\text{tors}]))$  corresponding to such a Nielsen class  $\eta$  is  $|\text{ind}(\eta)| + 2$ . Otherwise it is  $|\text{ind}(\eta)|$ . □*

### 4.3 Construction of maps using symplectic vector fields

We now construct a map  $\psi$  in our mapping class  $h$  so that in every Nielsen class  $\eta$ , the number of fixed points in this Nielsen class equals the rank of the summand of  $HF_*(\phi, Q(\mathbb{Z}/2[N'_h/\text{tors}]))$  corresponding to the Nielsen class  $\eta$ , which we computed in the previous section.

We start with a map  $\phi_{st}$ , a standard-form reducible map but which is the identity on any fixed components as opposed to having been perturbed by Hamiltonian flows. We next perturb by Hamiltonian flows on any components for which there was no cancellation in the previous section; that is, components for which the number of fixed points equaled the rank. These are components which have boundary components rotating in different directions as well as components which satisfy all of the criteria in Proposition 4.9.

Next we use a modified Hamiltonian on components  $S$  which meet a type III $d$  boundary, geometrically canceling the extremum with one of the type III $d$  fixed points. We start with a Hamiltonian function with at most one extremum on such a component, which patches together with the Hamiltonian on a neighborhood of the boundary of the pseudo-Anosov region as in the previous section.

**Lemma 4.10** *On a component  $S$  meeting a type III $d$  boundary, there exists a modification of the aforementioned Hamiltonian perturbation whose critical points are all nondegenerate saddle points.*

**Proof** We geometrically cancel one of the  $p$  type III $d$  fixed points and the fixed point corresponding to the minimum as in Figure 4. To do this, we consider, as in Figure 5, the perturbed situation but without the central disk excised. We draw a loop  $\gamma$ , excising the disk it bounds and replacing it with “the rest” of  $S$ , ie the portion to the left of  $\gamma$  in Figure 4. This reduces the situation to one standard case. We rescale the Hamiltonian on  $S$  to be small if necessary so there are points on which the Hamiltonian evaluates to a number less than the evaluation of the Hamiltonian at the (local) minimum.  $\square$

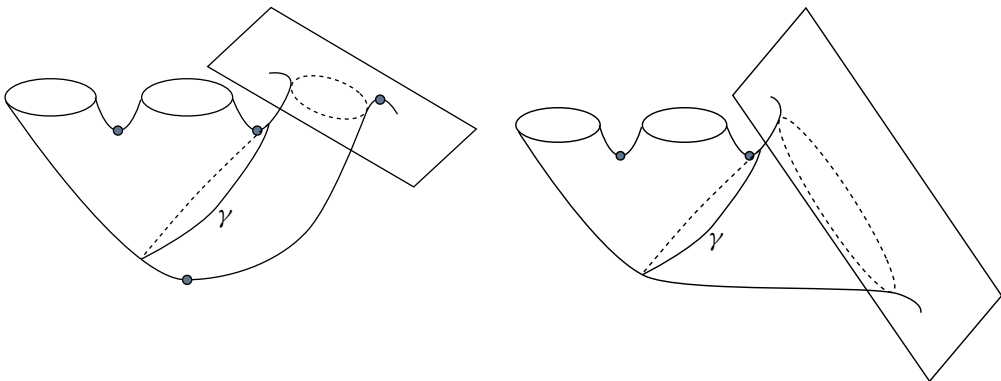

Figure 4: Geometrically canceling the minimum when meeting a type III $d$  boundary. Left: before. Right: after.

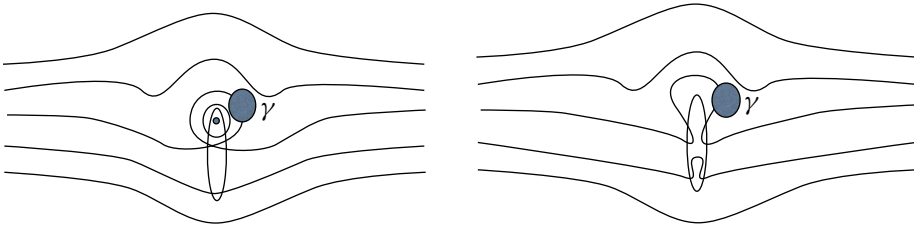

Figure 5: The perturbed type III d boundary with shaded  $\gamma$ -bounded disk to be excised and replaced with the rest of the component  $S$ , and unshaded region in which we are modifying the Hamiltonian. Left: before. Right: after.

Next we consider components  $S$  whose boundary components rotate all in the same direction and which meet no type III d boundaries, but have nonzero genus. In this case, we can use an  $S^1$ -valued Hamiltonian to remove extrema.

**Lemma 4.11** *There exists an  $S^1$ -valued Hamiltonian on such a component whose associated symplectic vector field is parallel to the boundary and whose critical points are all nondegenerate saddle points.*

**Proof** We modify the Hamiltonian away from the boundary as in Figure 6. □

Now we perturb this whole map by the flow of a small symplectic vector field.

**Lemma 4.12** *There exists a symplectic vector field  $V$  transverse to every boundary  $C$  of a reducible component for which  $[C] \neq 0$  in  $H_1(\Sigma, \partial\Sigma)$ .*

**Proof** The plan is to choose a totally irrational flux class. In order to see that we can choose the flow to be transverse to every reducing curve, we choose a handlebody

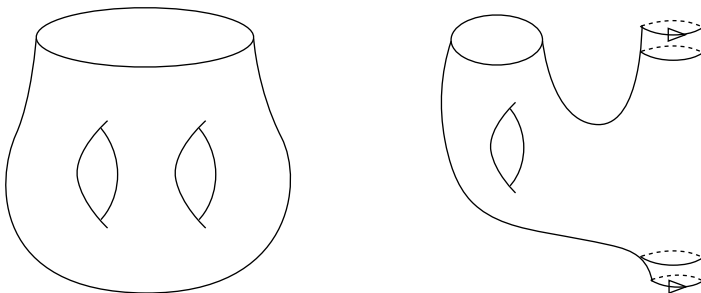

Figure 6: On a component which has genus, we can locally cancel the minimum geometrically with an  $S^1$ -valued Hamiltonian. Left: before. Right: after. The top and bottom circles marked with arrows are identified.

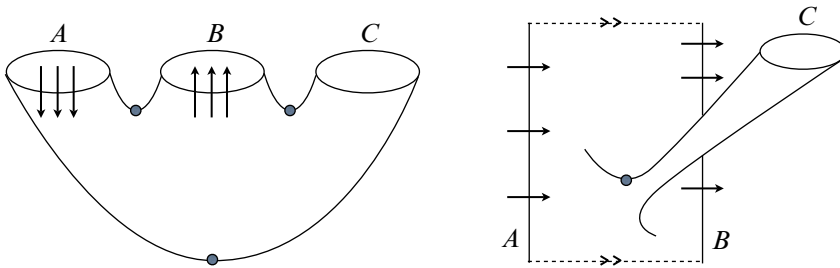

Figure 7: On a genus zero component, if the symplectic vector field is nonzero on at least one boundary component, then we can geometrically cancel the minimum with an  $S^1$ -valued Hamiltonian. Left: before. Right: after.

bounding  $\Sigma$  such that the reducing curves all bound disks. Next we collapse this to the underlying graph and put flows on each edge of the graph whose only rational dependences are given by balancing conditions at the vertices. We then use this as a guide to build the flow on the surface.  $\square$

We rescale the symplectic vector field so that it is small enough that its time-1 flow does not move any of the fixed points too much and does not create any new fixed points.

For components  $S$  whose boundary components rotate all in the same direction, which meet no type IIIId boundaries, and are genus zero but which have a non-nullhomologous boundary component, we now modify the symplectic vector field  $V$  in a neighborhood of the component, keeping it transverse to each reducing curve.

**Lemma 4.13** *There exists an  $S^1$ -valued Hamiltonian on such a component whose associated symplectic vector field is transverse to the boundary and whose critical points are all nondegenerate saddle points.*

**Proof** We modify the Hamiltonian away from the boundary as in Figure 7.  $\square$

We’ve shown:

**Proposition 4.14** *Given a reducible mapping class  $h$ , there exists a map  $\psi$  in the mapping class such that in every Nielsen class  $\eta$ , the number of fixed points in this Nielsen class equals the rank of the summand of  $HF_*(\phi, Q(\mathbb{Z}/2[N'_h/\text{tors}]))$  corresponding to the Nielsen class  $\eta$ .*  $\square$

Combining this with our observations regarding identity, periodic, pseudo-Anosov mapping classes and, for reducible mapping classes, with Proposition 4.9, we obtain (summing over Nielsen classes):

**Theorem 4.15** *The minimum number of fixed points of an area-preserving map  $\phi$  with nondegenerate fixed points in a mapping class  $h$  is given by*

$$\begin{cases} \sum_{\eta} |\text{ind}(\eta)| & \text{if } h \text{ is periodic or pseudo-Anosov,} \\ \sum_{\eta} |\text{ind}(\eta)| + 2A & \text{if } h \text{ is reducible,} \end{cases}$$

where  $A$  is the number of genus zero components of the reducible mapping class on which the map is the identity, which do not abut any pseudo-Anosov components, and all of whose boundary components rotate in the same direction and are nullhomologous or homologically boundary parallel.  $\square$

## 5 Degenerate fixed points

If we are allowed degenerate fixed points, each of the Nielsen classes  $\eta$  for which the bound for nondegenerate fixed points was  $|\text{ind}(\eta)|$  can be reduced to a single degenerate fixed point. To see this, note that the only of these situations in which we are not already reduced to a single fixed point are in cases in which the Nielsen class is associated with a  $p$ -prong pseudo-Anosov singularity or in which the Nielsen class is associated to a fixed component (possibly meeting type III<sub>d</sub> boundaries). In the former case, we simply modify the singular Hamiltonian  $H_{\text{sing}} = \mu r^2 \cos(p\theta) = \mu \text{Re}(z^p)/|z|^{p-2}$  to a smooth Hamiltonian which agrees with  $H_{\text{sing}}$  outside a small ball and inside a yet smaller ball is  $Cr^p \cos(p\theta) = C \text{Re}(z^p)$ , which is smooth at the origin, where it has a (generalized) monkey saddle. In the latter case, all of the fixed points are index negative one, ie are given by saddles, and we can again combine them all into the appropriate generalized monkey saddle, using  $p = |\text{ind}(\eta)| + 1$  (the index of such a degenerate fixed point is  $1 - p$ ).

Similarly, each of the Nielsen classes  $\eta$  for which the bound for nondegenerate fixed points was  $|\text{ind}(\eta)| + 2$  can be reduced to two fixed points: each of these corresponds to a genus zero component of the standard form map on which the map is the identity and for which each boundary component rotates in the same direction. Each of these in the nondegenerate case one index one fixed point, some number  $k$  of index negative one fixed points, where the component has  $k + 1$  boundary components. All of the index negative one fixed points can be combined in one degenerate fixed point of the

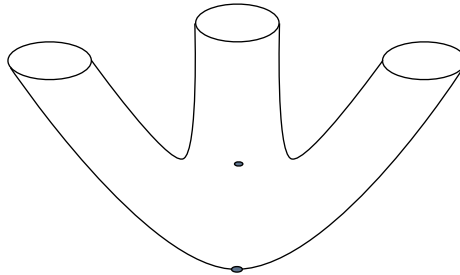

Figure 8: A three boundary component genus zero component with one minimum and, instead of two nondegenerate index negative one fixed points, one 3-prong monkey saddle.

same sort as in the previous paragraph. See Figure 8. Our task is now to show that we can do no better. That is, we cannot combine these two fixed points into one.

To show this, we use a cohomology operation. The argument has similarities with arguments that cup lengths give bounds on (even degenerate) fixed points, but even though we have, by [1, Section 2.5], a deformation-invariant module structure over the quantum homology of  $\Sigma$  (which agrees with  $H_*(\Sigma)$ ), the module structure is trivial. Every element of  $H_1(\Sigma)$  acts as zero because each of the descending manifolds from Lemma 4.7 is nullhomologous, and thus has zero algebraic intersection with any element of  $H_1(\Sigma)$ .

All is not lost, however. If we restrict our attention to one Nielsen class  $\eta$ , there is a sense in which this descending manifold is homologically essential for this Nielsen class.

**Lemma 5.1** *Let  $\Sigma$  be a surface of negative Euler characteristic,  $h$  reducible mapping class, and  $\eta$  a Nielsen class corresponding to a fixed component  $S$ . Then  $H_1(\Gamma(M_\phi)_\eta) \cong H_1(S)$  for any  $\phi \in h$ . In fact,  $\pi_1(\Gamma(M_\phi)_\eta) \cong \pi_1(S)$ . Furthermore, the image of*

$$H_1(\Gamma(M_\phi)_\eta) \rightarrow H_2(M_\phi) \rightarrow H_1(\Sigma)$$

*in  $H_1(\Sigma)$  agrees with the image of  $H_1(S) \rightarrow H_1(\Sigma)$ .*

**Proof** We consider  $\gamma$  as a map  $\mathbb{R} \rightarrow \Sigma$  with  $\gamma(t) = \phi(\gamma(t + 1))$ . An element of  $\pi_1(\Gamma(M_\phi)_\eta, \gamma)$  is of the form  $\gamma_s(t)$  for  $s \in S^1 = \mathbb{R}/\mathbb{Z}$  with  $\gamma_0(t) = \gamma(t)$ . We consider  $\alpha_0(s) = \gamma_s(0)$  and  $\alpha_1(s) = \gamma_s(1)$ . These are closed curves on  $\Sigma$  and  $\phi(\alpha_1(s)) = \alpha_0(s)$ . Furthermore,  $\alpha_0(s)$  is homotopic to  $\alpha_1(s)$  by the homotopy  $\alpha_t(s) = \gamma_s(t)$ .

As in [1, Lemma 3.2], we have a fibration  $\Omega\Sigma \rightarrow \Gamma(M_\phi) \rightarrow \Sigma$  and thus a long exact sequence on homotopy groups, a piece of which is

$$\pi_2(\Sigma, \gamma(0)) \rightarrow \pi_1(\Gamma(M_\phi), \gamma) \rightarrow \pi_1(\Sigma, \gamma(0)).$$

The image in  $\pi_1(\Sigma, \gamma(0))$  of the element of  $\pi_1(\Gamma(M_\phi), \gamma)$  represented by the homotopy  $\gamma_s(t)$  is represented by  $\alpha_0(s)$ . Because  $\Sigma$  is a surface of negative Euler characteristic,  $\pi_2(\Sigma) = 0$ . Thus we have an injection

$$\pi_1(\Gamma(M_\phi), \gamma) \hookrightarrow \pi_1(\Sigma, \gamma(0)).$$

We choose our map  $\phi$  (amongst those in the mapping class) to be a standard form one which is the identity on  $S$  and choose our basepoint  $\gamma$  to be the constant path at some point in  $S$ . We claim that the image of this map is  $\pi_1(S, \gamma(0))$ . We note that the image consists of elements of  $\pi_1(\Sigma, \gamma(0))$  represented by loops  $\alpha(s)$  based at  $\gamma(0)$  which are homotopic through loops based at  $\gamma(0)$  (because  $\gamma$  is the constant path) to  $\phi(\alpha(s))$ . Thus the image contains  $\pi_1(S, \gamma(0))$ .

We now claim that any  $\alpha(s)$  based at  $\gamma(0)$  homotopic to  $\phi(\alpha(s))$  through loops based at  $\gamma(0)$  can be homotoped inside  $S$ . This would give the result. This follows from [10, Lemma 3.4], with its modification to the standard form maps for the area-preserving case (in which we need to consider multiple parallel Dehn twist regions with fixed annuli in between) given in [1, Lemma 3.8 and Corollary 3.9]. These state that any path between two fixed points of a standard form map which is homotopic rel endpoints to  $\phi$  applied to itself can be homotoped inside the fixed point set of  $\phi$ . The component of  $\text{Fix}(\phi)$  containing  $\gamma(0)$  is simply  $S$ .

Finally, we note that the result continues to hold for any other map in the mapping class. Nielsen classes are well-defined on the entire mapping class  $h$  by [1, Lemma 4.2], so this statement is sensible.  $\square$

Now we restrict our attention to fixed genus zero components  $S$  which do not meet type IIIId boundaries, and whose boundary components all rotate in the same direction and are all nullhomologous.

**Lemma 5.2** *The Floer homology chain complex  $CF_*(\phi, \mathbb{Z}/2[H_1(\Gamma(M_\phi)_\eta)]; \eta)$  of a map  $\phi \in h$ , restricted to Nielsen class  $\eta$  summand of such a fixed component  $S$ , with coefficients in the representation  $\mathbb{Z}/2[H_1(\Gamma(M_\phi)_\eta)]$ , is well defined on the entire mapping class  $h$  and invariant up to quasi-isomorphism. The same holds for  $CF_*(\phi, \mathbb{Z}/2; \eta)$ , where the coefficients are the trivial representation  $\mathbb{Z}/2$ .*



**Proof** It is well-defined for any  $\phi$  because  $\omega_\phi: H_1(\Gamma(M_\phi)_\eta) \rightarrow \mathbb{R}$  is the zero map for any  $\phi$  (which implies that every  $\phi$  is  $\eta$ -weakly monotone as defined in [1]). This follows because  $\omega_\phi: H_1(\Gamma(M_\phi)_\eta) \rightarrow \mathbb{R}$  agrees with the map

$$H_1(\Gamma(M_\phi)_\eta) \rightarrow (\ker(c_\phi) \subset H_2(M_\phi)) \rightarrow (N_h \subset H_1(\Sigma)) \xrightarrow{\text{Flux}} \mathbb{R},$$

and the image of  $H_1(\Gamma(M_\phi)_\eta)$  under all but the last composition is the image of  $H_1(S) \rightarrow H_1(\Sigma)$ , by Lemma 5.1. This, however, is zero because  $S$  has genus zero so that  $H_1(\partial S)$  surjects to  $H_1(S)$ , but we've assumed the boundary of  $S$  is nullhomologous in  $\Sigma$ . The invariance up to quasi-isomorphism follows from Theorem 2.8(ii).  $\square$

We compute with  $\phi$  a standard form map. We assume without loss of generality that the Morse–Smale function on the component  $S$  has one extremum, a minimum (otherwise reverse orientation on  $\Sigma$ ). The homology  $HF_*(\phi, \mathbb{Z}/2; \eta)$  has dimension  $|\text{ind}(\eta)| + 2$ , generated by a fixed point  $y$  corresponding to the minimum and  $|\text{ind}(\eta)| + 1$  fixed points  $x_i$  of index negative one.

Consider a homomorphism

$$\begin{aligned} \beta \in \text{Hom}(H_1(\Gamma(M_\phi)_\eta), \mathbb{Z}/2) &= \text{Hom}(H_1(S), \mathbb{Z}/2) \\ &= H^1(S; \mathbb{Z}/2) = H_1(S, \partial S; \mathbb{Z}/2). \end{aligned}$$

As in [9, Section 12.1.3] and [1, Section 2.5] we get a degree one map

$$\partial_\beta: HF_*(\phi, \mathbb{Z}/2; \eta) \rightarrow HF_*(\phi, \mathbb{Z}/2; \eta)$$

defined by

$$\partial_\beta z = \sum_w \sum_{C \in \mathcal{M}_1(z,w)} \beta([C \cdot C_{z,w}^{-1}]) \cdot w.$$

Moreover, we show in [1, Proof of Proposition 2.9] that  $\partial_\beta$  is well-defined (purely algebraically) up to quasi-isomorphism of the pair

$$CF_*(\phi, \mathbb{Z}/2[H_1(\Gamma(M_\phi)_\eta)]; \eta) \quad \text{and} \quad CF_*(\phi, \mathbb{Z}/2; \eta).$$

Thus, by Lemma 5.2,  $\partial_\beta$  is a well-defined operation  $HF_*(h, \mathbb{Z}/2; \eta)$  on the  $\eta$  component of the Floer homology for the mapping class  $h$ . This operation is what replaces quantum cup products such as in [17] in a cup-length argument.

**Lemma 5.3** *There is a  $\beta$  such that  $\partial_\beta x_i = y$ . In fact, for any sum  $\sum_i c_i x_i$  with  $c_1 \in \mathbb{Z}/2$  not all zero, there exists a  $\beta$  such that  $\partial_\beta \sum_i c_i x_i = y$ .*

**Proof** We simply take  $\beta$  to be the class in  $H_1(\Sigma, \partial\Sigma; \mathbb{Z}/2)$  of an arc meeting the closure of the descending manifold of the saddle point corresponding to an  $x_i$  appearing with coefficient one once and all others zero times. See Figure 3 for a picture of the descending manifolds.  $\square$

Thus the “cup-length” of  $HF_*(h, \mathbb{Z}/2; \eta)$  as an  $H^1(S)$ -module is two.

We will be taking a limit in which degenerate fixed points are allowed to appear. We have need of a Gromov compactness result appropriate for such a situation. We use Taubes’s currents-in-the-target version of Gromov compactness (valid in dimension four) [19, Proposition 3.3] as applied to compact subsets  $[a, b] \times M_\phi$  in [8, Lemma 9.9].

**Proposition 5.4** [19, Proposition 3.3; 8, Lemma 9.9] *Let  $u_k : \mathbb{R} \times [0, 1] \rightarrow \mathbb{R} \times M_\phi$  be a sequence of holomorphic sections with energies bounded by some  $E_0$ . Then we can pass to a subsequence such that*

- (i) *the  $u_k$  converge weakly as currents in  $\mathbb{R} \times M_\phi$  to a proper pseudoholomorphic map  $u : \mathbb{R} \times [0, 1] \rightarrow \mathbb{R} \times M_\phi$ , and*
- (ii) *for any compact  $K \subset \mathbb{R} \times M_\phi$ ,*

$$\lim_{k \rightarrow \infty} \left[ \sup_{x \in \text{Im}(u_k) \cap K} \text{dist}(x, \text{Im}(u)) + \sup_{x \in \text{Im}(u) \cap K} \text{dist}(x, \text{Im}(u_k)) \right] = 0. \quad \square$$

From this we see that we have  $C^0$ -convergence to the orbit corresponding to a fixed point at each end.

**Theorem 5.5** *There must be at least two fixed points in the Nielsen class  $\eta$  corresponding to such a fixed component  $S$  even if we allow degenerate fixed points.*

**Proof** Suppose there is just one, necessarily degenerate, fixed point in Nielsen class  $\eta$ . Perturb by a small Hamiltonian flow such that all fixed points are nondegenerate. Because  $HF_*(h, \mathbb{Z}/2; \eta)$  has rank one in even degree, we have at least one index-one fixed point which survives in homology; choose one such and call it  $y$ . By Lemma 5.3, for any index negative one fixed point  $x$  which survives in homology, there is a  $\beta \in H_1(S, \partial S)$  such that  $\partial_\beta[x] = [y]$ . Thus there are (at least) two flow-lines from  $x$  to  $y$ , and there are two such that the difference between their classes, mapped to  $H_1(S; \mathbb{Z}/2)$ , is nonzero.

We now take a limit of small perturbations limiting to the degenerate situation. By Proposition 5.4, after passing to a subsequence, the two flow-lines  $u_k$  and  $v_k$  above limit to holomorphic curves  $u, v: \mathbb{R} \times [0, 1] \rightarrow \mathbb{R} \times M_\phi$ , which  $C^0$ -limit to the degenerate fixed point at each end. Thus each of these two limits give continuous loops in  $\Gamma(M_\phi)_\eta$ . We additionally see that  $[u] - [v] = \lim_{k \rightarrow \infty} [u_k - v_k]$  in  $H_1(\Gamma(M_\phi)_\eta) \cong H_1(S)$ . This latter limit is nonzero, and in particular at least one of  $u, v$  is nonconstant and thus has positive energy. However,  $\omega_\phi: H_1(\Gamma(M_\phi)_\eta) \rightarrow \mathbb{R}$  is the zero map, so we see that each of  $u, v$  has zero energy, a contradiction.  $\square$

Summing over Nielsen classes, we conclude:

**Theorem 5.6** *The minimum number of fixed points of an area-preserving map  $\phi$  in a mapping class  $h$  is given by*

$$\begin{cases} \#\{\eta : \text{ind}(\eta) \neq 0\} & \text{if } h \text{ is periodic or pseudo-Anosov,} \\ \#\{\eta : \text{ind}(\eta) \neq 0\} + A + B & \text{if } h \text{ is reducible,} \end{cases}$$

where  $A$  is as before and  $B$  is the number of fixed annuli.

## References

- [1] **A Cotton-Clay**, *Symplectic Floer homology of area-preserving surface diffeomorphisms*, *Geom. Topol.* 13 (2009) 2619–2674 MR Zbl
- [2] **A W Cotton-Clay**, *Symplectic Floer homology of area-preserving surface diffeomorphisms and sharp fixed point bounds*, PhD thesis, University of California, Berkeley (2009) MR Available at <https://www.proquest.com/docview/304844677>
- [3] **S Dostoglou, D A Salamon**, *Self-dual instantons and holomorphic curves*, *Ann. of Math.* 139 (1994) 581–640 MR Zbl
- [4] **A Fathi, F Laudenbach, V Poénaru** (editors), *Travaux de Thurston sur les surfaces*, *Astérisque* 66–67, Soc. Math. France, Paris (1979) MR Zbl
- [5] **A Floer, H Hofer, D Salamon**, *Transversality in elliptic Morse theory for the symplectic action*, *Duke Math. J.* 80 (1995) 251–292 MR Zbl
- [6] **M Gromov**, *Pseudoholomorphic curves in symplectic manifolds*, *Invent. Math.* 82 (1985) 307–347 MR Zbl
- [7] **K Honda, W H Kazez, G Matić**, *Right-veering diffeomorphisms of compact surfaces with boundary*, *Invent. Math.* 169 (2007) 427–449 MR Zbl
- [8] **M Hutchings**, *An index inequality for embedded pseudoholomorphic curves in symplectizations*, *J. Eur. Math. Soc.* 4 (2002) 313–361 MR Zbl

- [9] **M Hutchings, M Sullivan**, *Rounding corners of polygons and the embedded contact homology of  $T^3$* , *Geom. Topol.* 10 (2006) 169–266 MR Zbl
- [10] **B J Jiang, J H Guo**, *Fixed points of surface diffeomorphisms*, *Pacific J. Math.* 160 (1993) 67–89 MR Zbl
- [11] **Y-J Lee**, *Heegaard splittings and Seiberg–Witten monopoles*, from “Geometry and topology of manifolds”, *Fields Inst. Commun.* 47, Amer. Math. Soc., Providence, RI (2005) 173–202 MR Zbl
- [12] **Y-J Lee**, *Reidemeister torsion in Floer–Novikov theory and counting pseudo-holomorphic tori, I*, *J. Symplectic Geom.* 3 (2005) 221–311 MR Zbl
- [13] **Y-J Lee**, *Reidemeister torsion in Floer–Novikov theory and counting pseudo-holomorphic tori, II*, *J. Symplectic Geom.* 3 (2005) 385–480 MR Zbl
- [14] **Y-J Lee, C H Taubes**, *Periodic Floer homology and Seiberg–Witten–Floer cohomology*, *J. Symplectic Geom.* 10 (2012) 81–164 MR Zbl
- [15] **T Perutz**, *Lagrangian matching invariants for fibred four-manifolds, II*, *Geom. Topol.* 12 (2008) 1461–1542 MR Zbl
- [16] **J Robbin, D Salamon**, *The spectral flow and the Maslov index*, *Bull. London Math. Soc.* 27 (1995) 1–33 MR Zbl
- [17] **M Schwarz**, *A quantum cup-length estimate for symplectic fixed points*, *Invent. Math.* 133 (1998) 353–397 MR Zbl
- [18] **P Seidel**, *Symplectic Floer homology and the mapping class group*, *Pacific J. Math.* 206 (2002) 219–229 MR Zbl
- [19] **C H Taubes**, *The structure of pseudoholomorphic subvarieties for a degenerate almost complex structure and symplectic form on  $S^1 \times B^3$* , *Geom. Topol.* 2 (1998) 221–332 MR Zbl
- [20] **W P Thurston**, *On the geometry and dynamics of diffeomorphisms of surfaces*, *Bull. Amer. Math. Soc.* 19 (1988) 417–431 MR Zbl
- [21] **M Usher**, *Vortices and a TQFT for Lefschetz fibrations on 4-manifolds*, *Algebr. Geom. Topol.* 6 (2006) 1677–1743 MR Zbl
- [22] **L H Vân, K Ono**, *Symplectic fixed points, the Calabi invariant and Novikov homology*, *Topology* 34 (1995) 155–176 MR Zbl With Appendix C written jointly with T Q T Lê

Fullpower Technologies  
 Santa Cruz, CA, United States  
 cottonclay@gmail.com

Proposed: Peter Teichner  
 Seconded: András I Stipsicz, Ciprian Manolescu

Received: 25 February 2014  
 Revised: 7 November 2021

# High-energy harmonic maps and degeneration of minimal surfaces

CHARLES OUYANG

Let  $S$  be a closed surface of genus  $g \geq 2$  and  $\rho$  a maximal  $\mathrm{PSL}(2, \mathbb{R}) \times \mathrm{PSL}(2, \mathbb{R})$  surface group representation. By a result of Schoen, there is a unique  $\rho$ -equivariant minimal surface  $\tilde{\Sigma}$  in  $\mathbb{H}^2 \times \mathbb{H}^2$ . We study the induced metrics on these minimal surfaces and prove the limits are precisely mixed structures. We prove a similar result for maximal surfaces in  $\mathrm{AdS}^3$ . In the second half of the paper, we provide a geometric interpretation: the minimal surfaces  $\tilde{\Sigma}$  degenerate to the core of a product of two  $\mathbb{R}$ -trees. As a consequence, we obtain a compactification of the space of maximal representations of  $\pi_1(S)$  into  $\mathrm{PSL}(2, \mathbb{R}) \times \mathrm{PSL}(2, \mathbb{R})$ .

49Q05, 53C43

1. Introduction and main results	1692
2. Geometric preliminaries	1695
3. Minimal lagrangians	1703
4. Embedding of the induced metrics	1705
5. Compactification of the induced metrics	1712
6. Analysis of the limits	1725
7. Applications to maximal surfaces in $\mathrm{AdS}^3$	1739
8. Compactification of maximal representations	1742
References	1743

## 1 Introduction and main results

Let  $S$  be a closed, orientable, smooth surface of genus  $g > 1$ . For any reductive Lie group  $G$ , one can form the character variety  $\mathcal{R}(\pi_1(S), G) = \text{Hom}^+(\pi_1(S), G) // G$ , consisting of conjugacy classes of reductive surface group representations into  $G$ . In the classical setting, where  $G = \text{PSL}(2, \mathbb{R})$ , one recovers a copy of Teichmüller space. A goal in the higher Teichmüller theory is to understand geometric aspects of surface group representations into higher-rank Lie groups.

Following the work of Labourie [23], given a reductive surface group representation  $\rho$  into a semisimple Lie group  $G$ , to each complex structure  $J$  on the surface  $S$ , one can record the energy of the unique  $\rho$ -equivariant harmonic map from  $(\tilde{S}, J)$  to the Riemannian symmetric space  $G/K$ . This defines an energy functional on Teichmüller space, and Labourie proves that if the original representation  $\rho$  is *Anosov*, then the energy functional admits a critical point. Hence, to each such representation  $\rho$ , there is an associated branched immersed minimal surface in the symmetric space  $G/K$ .

The existence and uniqueness of the minimal surface in the associated symmetric space has been resolved by Labourie [24] for the rank-two real split simple Lie groups: namely  $\text{SL}(3, \mathbb{R})$ ,  $\text{PSp}(4, \mathbb{R})$  and  $G_2$ . Interestingly enough, the result still holds when  $G$  is merely semisimple, as the case of  $\text{PSL}(2, \mathbb{R}) \times \text{PSL}(2, \mathbb{R})$  was proven by Schoen in [39].

There is also the aim in the program of the higher Teichmüller theory to understand representations as geometric objects. This is a natural goal, given that in the case of classical Teichmüller theory, where the group is  $G = \text{PSL}(2, \mathbb{R})$  and the representation is discrete and faithful, the associated geometric objects are given by marked hyperbolic surfaces. Moreover, it is of interest to obtain a description of boundary points associated to higher Teichmüller spaces in terms of degenerations of geometric objects. It would be interesting to have these geometric objects at the boundary be a generalization of measured laminations (see [43, Section 11]), which are the limiting geometric objects in the Thurston compactification of Teichmüller space.

In the setting  $G = \text{PSL}(2, \mathbb{R}) \times \text{PSL}(2, \mathbb{R})$ , this paper does exactly that: we provide a parametrization of maximal surface group representations into  $\text{PSL}(2, \mathbb{R}) \times \text{PSL}(2, \mathbb{R})$ , by studying the induced metrics on the  $\rho$ -equivariant minimal surfaces in the symmetric space  $\mathbb{H}^2 \times \mathbb{H}^2$ . If  $\rho = (\rho_1, \rho_2)$ , and  $\tilde{\Sigma}$  is the unique  $\rho$ -equivariant minimal surface in  $\mathbb{H}^2 \times \mathbb{H}^2$ , then its quotient by the action of the fundamental group via the representation

is the graph of the unique minimal lagrangian isotopic to the identity between  $(S, g_1) = \mathbb{H}^2/\rho_1$  and  $(S, g_2) = \mathbb{H}^2/\rho_2$ .

Let  $\text{Ind}(S)$  be the equivalence class of induced metrics on the graph minimal surface in the product of two hyperbolic surfaces. Two such metrics are identified if one is the pullback metric of the other by a diffeomorphism homotopic to the identity map.

We study the length spectrum of these induced metrics on the minimal surface and show that we can degenerate the metrics to obtain singular flat metrics, measured laminations and mixed structures. A *mixed structure*  $\eta = (S_\alpha, q_\alpha, \lambda)$  is the data of a collection of incompressible subsurfaces  $\bigsqcup S_\alpha$ , with a prescribed meromorphic (integrable) quadratic differential on each subsurface (collapsing the boundary components and viewing them as punctures), with a measured lamination  $\lambda$  supported on the complement  $S \setminus \bigsqcup S_\alpha$ . Observe that a holomorphic quadratic differential on  $S$  and a measured lamination on  $S$  are trivial examples of mixed structures, where  $S_\alpha = S$  and  $S_\alpha = \emptyset$ , respectively. Define then  $\text{PMix}(S)$  to be the space of projectivized mixed structures. Our first main result is the following.

**Theorem A** *The space  $\text{Ind}(S)$  of induced metrics embeds into the space  $\text{PCurr}(S)$  of projectivized currents. Its closure is  $\text{Ind}(S) \sqcup \text{PMix}(S)$ .*

If we keep track of the ambient space, namely  $\mathbb{H}^2 \times \mathbb{H}^2$ , we show that by scaling the ambient space by a suitable sequence of constants (which generally will be the total energy of a harmonic map), we can obtain as limits of minimal lagrangians the core of a pair of  $\mathbb{R}$ -trees coming from measured foliations. In fact, we show there is an isometric embedding from a metric space obtained from the data of a mixed structure to the core of trees.

As a consequence, we have an answer to our original goal of ascribing something geometric to maximal surface group representations into  $\text{PSL}(2, \mathbb{R}) \times \text{PSL}(2, \mathbb{R})$ . By studying degenerations of the minimal lagrangians, we obtain natural boundary objects which are both geometric and are natural extensions of measured laminations.

**Theorem B** *The space of maximal representations of  $\text{PSL}(2, \mathbb{R}) \times \text{PSL}(2, \mathbb{R})$  embeds into the space of  $\pi_1 S$ -equivariant minimal lagrangians in  $\mathbb{H}^2 \times \mathbb{H}^2$ . The scaled Gromov–Hausdorff limits of the minimal lagrangians are given by the core of a product  $T_1 \times T_2$  of trees, where  $T_1$  and  $T_2$  are a pair of  $\mathbb{R}$ -trees coming from a projective pair of measured foliations.*

Minimal lagrangians in  $\mathbb{H}^2 \times \mathbb{H}^2$  arise as the image of the Gauss map of the unique embedded spacelike maximal surface in a Globally Hyperbolic Maximal Compact (GHMC)  $\text{AdS}^3$ -manifold; see [22]. Mess [28] showed that the maximal representations into  $\text{PSL}(2, \mathbb{R}) \times \text{PSL}(2, \mathbb{R})$  are precisely the holonomy representations of GHMC  $\text{AdS}^3$ -structures. One could have studied maximal representations into  $\text{PSL}(2, \mathbb{R}) \times \text{PSL}(2, \mathbb{R})$  by looking at the induced metric on the maximal surface instead. We show an analogue of Theorem A, that the limits one obtains are also mixed structures. If  $\text{Max}(S)$  denotes the space of induced metrics on the maximal surface, then our final result is the following.

**Theorem C** *The space  $\text{Max}(S)$  of induced metrics on the maximal surfaces embeds into the space  $\text{PCurr}(S)$  of projectivized currents. Its closure is  $\text{Max}(S) \sqcup \text{PMix}(S)$ .*

There has been some recent interest in studying surface group representations to the Lie group  $\text{PSL}(2, \mathbb{R}) \times \text{PSL}(2, \mathbb{R})$  by way of geodesic currents. Work of Glorieux [15] shows that the average of two Liouville currents,  $\frac{1}{2}(L_{X_1} + L_{X_2})$ , yields the length spectrum of the Globally Hyperbolic Maximal Compact  $\text{AdS}^3$  manifold with holonomy  $(\rho_1, \rho_2)$ , where  $X_i = \mathbb{H}^2 \setminus \rho_i$ . In another recent paper of Glorieux [16], it is shown that this map which sends unordered pairs of elements in Teichmüller space to the space of projectivized currents, given by  $(X_1, X_2) = (X_2, X_1) \rightarrow \frac{1}{2}(L_{X_1} + L_{X_2})$ , is injective. Recent work of Burger, Iozzi, Parreau and Pozzetti [6] show the limits of this embedding are given by the projectivization of a pair of measured laminations. The limiting current  $\eta$  thus satisfies

$$(1-1) \quad i(\eta, \cdot) = i(\lambda_1, \cdot) + i(\lambda_2, \cdot),$$

where  $\lambda_1$  and  $\lambda_2$  are specific representatives of the projectivize classes  $[\lambda_1]$  and  $[\lambda_2]$ , respectively, representing limits on the Thurston boundary.

We remark that our compactification via geodesic currents is distinct. If the limiting laminations  $\lambda_1$  and  $\lambda_2$  fill, that is, the sum of their intersection numbers with any third measured lamination is never zero, then the corresponding limiting object  $\eta'$  under our compactification is a singular flat metric coming from a unit-norm holomorphic quadratic differential  $\Phi$  whose horizontal and vertical laminations are  $\lambda_1$  and  $\lambda_2$ . The corresponding current is thus given by

$$(1-2) \quad l_{|\Phi|}^2(\alpha) = i^2(\eta', \alpha) = i^2(\lambda_1, \alpha) + i^2(\lambda_2, \alpha)$$

for a suitably short arc  $\alpha$  away from the zeros of  $|\Phi|$ . In general, this is different from the sum of  $\lambda_1$  and  $\lambda_2$ . Notice that for  $\gamma$  an arc of the horizontal lamination of  $\Phi$ ,



the two intersection numbers  $i(\eta, \alpha)$  and  $i(\eta', \alpha)$  coincide, so that the two currents  $\eta$  and  $\eta'$  are distinct even as projectivized currents. However, using their limiting currents, Burger, Iozzi, Parreau and Pozzetti are able to construct and interpret their boundary objects as subbuildings in the product of trees, endowed with the  $L^1$ -metric.

Finally, since the first version of this paper appeared, related work has been done on some of the other rank-two Lie groups; see Ouyang and Tamburelli [34; 35; 36]. More recently, together with Martone and Tamburelli [26], we have described our compactification as a closed ball, upon which the mapping class group acts.

**Acknowledgements** It is the author's privilege to thank his advisor Mike Wolf for first suggesting the problem and for his continued patience, support and guidance. The author would like to express his gratitude to Zeno Huang and Andrea Tamburelli for many fruitful conversations throughout this project. He would also like to thank Chris Leininger and Ivo Slegers for helpful comments on an earlier draft. Finally, he would like to thank the referee for the many careful comments to improve the paper. The author acknowledges support from the National Science Foundation through grant DMS-1564374.

## 2 Geometric preliminaries

### 2.1 Harmonic maps between surfaces

Let  $(M, \sigma |dz|^2)$  and  $(N, \rho |dw|^2)$  be two closed Riemannian surfaces and

$$w: (M, \sigma |dz|^2) \rightarrow (N, \rho |dw|^2)$$

a Lipschitz map. Then the energy of the map  $w$  is given by the integral

$$\mathcal{E}(w) := \frac{1}{2} \int_M \|dw\|^2 d\text{vol}_\sigma.$$

A critical point of the energy functional is a *harmonic map*. The energy density of the map  $w$ , defined almost everywhere, is given by

$$e(w) = \frac{\rho(w(z))}{\sigma(z)} (|w_z|^2 + |w_{\bar{z}}|^2),$$

and so the total energy is also given by the formula

$$\mathcal{E}(w) = \int_M e(w) \sigma dz \wedge d\bar{z} = \int_M \rho(w(z)) (|w_z|^2 + |w_{\bar{z}}|^2) dz \wedge d\bar{z},$$

which shows the total energy depends only upon the conformal structure of the domain surface but on the metric of the target. Alternatively, a harmonic map  $w$  solves the Euler–Lagrange equation for the energy functional, a second-order nonlinear PDE,

$$w_{z\bar{z}} + (\log \rho)_w w_z w_{\bar{z}} = 0.$$

To any harmonic map  $w : (M, \sigma |dz|^2) \rightarrow (N, \rho |dw|^2)$ , the pullback of the metric tensor decomposes by type according to

$$w^*(\rho |dw|^2) = \Phi dz^2 + \sigma e dz d\bar{z} + \bar{\Phi} d\bar{z}^2,$$

where  $\Phi dz^2$  is a holomorphic quadratic differential with respect to the complex structure coming from the conformal class of  $(M, \sigma |dz|^2)$ , called the *Hopf differential* of  $w$ . Much of the formulas arising from harmonic maps make use of the auxiliary functions

$$\mathcal{H} = \frac{\rho(w(z))}{\sigma(z)} |w_z|^2 \quad \text{and} \quad \mathcal{L} = \frac{\rho(w(z))}{\sigma(z)} |w_{\bar{z}}|^2.$$

We list some of these formulas and make liberal use of them without always explicitly citing the precise one:

- The energy density  $e = \mathcal{H} + \mathcal{L}$ .
- The Jacobian  $\mathcal{J} = \mathcal{H} - \mathcal{L}$ .
- The norm of the quadratic differential

$$\frac{|\Phi|^2}{\sigma^2} = \mathcal{H}\mathcal{L}.$$

- The Laplace–Beltrami operator

$$\Delta \equiv \frac{4}{\sigma} \frac{\partial^2}{\partial z \partial \bar{z}}.$$

- Gaussian curvature of the source

$$K(\sigma) = -\frac{2}{\sigma} \frac{\partial^2 \log \sigma}{\partial z \partial \bar{z}}.$$

- Gaussian curvature of the target

$$K(\rho) = -\frac{2}{\rho} \frac{\partial^2 \log \rho}{\partial w \partial \bar{w}}.$$

- The Beltrami differential

$$v = \frac{w_{\bar{z}}}{w_z} = \frac{\bar{\Phi}}{\sigma \mathcal{H}}, \quad \text{with } |v|^2 = \frac{\mathcal{L}}{\mathcal{H}}.$$

The Bochner formula is given by

$$\begin{aligned}\Delta \log \mathcal{H} &= -2K(\rho)\mathcal{H} + 2K(\rho)\mathcal{L} + 2K(\sigma) \quad \text{when } \mathcal{H}(p) \neq 0, \\ \Delta \log \mathcal{L} &= -2K(\rho)\mathcal{L} + 2K(\rho)\mathcal{H} + 2K(\sigma) \quad \text{when } \mathcal{L}(p) \neq 0.\end{aligned}$$

We shall often be in the setting where both the source and target are hyperbolic surfaces, that is,  $K(\sigma) = K(\rho) \equiv -1$ , and so some of the formulas listed above can be simplified. In the more general setting where the target has negative curvature, the existence of a harmonic map in the homotopy class is due to Eells and Sampson [11], its uniqueness is due to Hartman [19] and Al'ber [1], and the fact that if the homotopy class contains a diffeomorphism, then the harmonic map itself is a diffeomorphism and  $\mathcal{H} > 0$ , is due to Schoen and Yau [40] and Sampson [38].

## 2.2 Teichmüller space

Recall that Teichmüller space  $\mathcal{T}(S)$  is the space of all hyperbolic metrics on  $S$  with the identification  $g \sim h$  if there exists a diffeomorphism  $\phi$  of the surface, homotopic to the identity map, for which  $\phi^*g = h$ . The topology is given by its marked length spectrum.

Alternatively, one may regard Teichmüller space as the space of marked Riemann surfaces. For a fixed surface  $S$ , two complex structures  $(S, J_1)$  and  $(S, J_2)$  are identified if there exists a biholomorphism  $f: (S, J_1) \rightarrow (S, J_2)$  which is homotopic to the identity. The topology is given by the metric which, for two points of Teichmüller space, assigns the logarithm of the quasiconformal dilatation of the unique Teichmüller mapping between the marked Riemann surfaces.

Teichmüller space is topologically trivial, being homeomorphic to an open ball of dimension  $6g - 6$ .

## 2.3 Measured foliations and measured laminations

For a closed surface  $S$ , a measured foliation  $(S, \mathcal{F})$  is a singular foliation (finitely many  $k$ -pronged singularities, with  $k \in \{3, 4, \dots\}$ ) with a transverse measure, that is, a measure  $\mu$  defined on each arc transverse to the foliation, such that the measure is invariant under isotopy between two arcs through transverse arcs.

To any isotopy class of measured foliations, there is an associated measured lamination. A measured geodesic lamination on a hyperbolic surface is a closed disjoint set of

geodesics with a transverse measure. Likewise, to any measured lamination, there is an associated measured foliation, so that there is a canonical way to pass from one to the other; see [7] and [37]. Hence, the space of measured laminations does not depend upon the choice of hyperbolic metric. Thurston showed that both spaces are homeomorphic to Euclidean balls of dimension  $6g - 6$ ; see [12] and [42].

## 2.4 Holomorphic quadratic differentials

The space of holomorphic quadratic differentials  $Q_g$  is a holomorphically trivializable vector bundle over Teichmüller space, whose fiber over the Riemann surface  $X$  is the vector space of holomorphic quadratic differentials on  $X$ . It is the vector space of holomorphic sections of the square of the canonical bundle  $K_X$ , and so may be written  $H^0(X, K_X^2)$ . By the Riemann–Roch theorem, the complex dimension of this vector space is  $3g - 3$ . More concretely, if  $X$  is a Riemann surface and  $q$  is a holomorphic quadratic differential on  $X$ , then locally  $q = f(z) dz^2$ , where  $f$  is a holomorphic function and  $z$  is a chart for  $X$ .

Holomorphicity of the differential and compactness of the Riemann surface ensures the quadratic differential has precisely  $4g - 4$  zeros counted with multiplicity. Hence, in a neighborhood avoiding a zero of  $q$ , one may choose natural coordinates  $\zeta$  so that  $q = d\zeta^2$ . The metric  $|q|$  is well-defined on the complement of the zeros and is locally Euclidean. At the zeros, the metric has conic singularities of angle  $(n + 2)\pi$ , where  $n$  is the order of the zero of the quadratic differential at that point.

For any point on the complement of the zeros of the quadratic differential, there is a unique direction for which  $q(v, v) \in \mathbb{R}^+$ . Integrating the resulting line field, one obtains a foliation, called the *horizontal foliation* of the quadratic differential  $q$ . Likewise, one can define the *vertical foliation* of  $q$ , by integrating the line field of directions for which  $q(v, v) \in \mathbb{R}^-$ . The foliations come equipped with a transverse measure. For any arc  $\gamma$  transverse to the horizontal foliation, the measure for the horizontal foliation is given by

$$\tau_h = \int_{\gamma} |\operatorname{Im}(\sqrt{f})(z)| |dz|,$$

and likewise, the transverse measure for the vertical foliation is given by integrating the real part  $|\operatorname{Re}(\sqrt{q})|$  over an arc  $\gamma$ .

If  $S_{g,n}$  is a compact surface of genus  $g$  with  $n$  punctures such that  $3g - 3 + n > 0$ , then  $Q_{g,n}$  will denote the space of integrable holomorphic quadratic differentials on  $S_{g,n}$ . At each of the punctures, the differential has a pole of order one.

## 2.5 Geodesic currents and marked length spectra

Let  $(S, \sigma)$  be a fixed closed hyperbolic surface of genus  $g \geq 2$ . Then its universal cover  $\tilde{S}$  may be identified isometrically with  $\mathbb{H}^2$ . Let  $G(\tilde{S})$  denote the space of geodesics of  $\tilde{S}$ . Then a geodesic current on  $S$  is a  $\pi_1(S)$ -equivariant Radon measure on  $G(\tilde{S})$ . The space of geodesic currents, denoted by  $\text{Curr}(S)$ , is given by the weak\* topology.

**Remark** A priori, the definition of a geodesic current may appear to depend upon the choice of hyperbolic metric, but it turns out  $G(\tilde{S})$  depends only upon  $\pi_1(S)$ ; see [4]. Hence the space of geodesic currents is independent of the hyperbolic metric initially chosen for  $S$ .

The ur-example of a geodesic current is given by a single closed geodesic  $\gamma$  on  $S$ . Lift  $\gamma$  to a discrete set of geodesics  $\tilde{\gamma}$  on  $\tilde{S}$ . These lifted geodesics may be given a Dirac measure, which is  $\pi_1(S)$ -invariant as the lifts themselves are  $\pi_1(S)$ -invariant. Hence for any closed curve, by looking at its geodesic representative, one obtains a geodesic current on  $S$ . In fact, Bonahon [4] shows the space of weighted closed curves is dense in  $\text{Curr}(S)$  and the geometric intersection number between curves has a continuous bilinear extension to  $i: \text{Curr}(S) \times \text{Curr}(S) \rightarrow \mathbb{R}_{\geq 0}$ . Moreover, a geodesic current on  $S$  is determined by its intersection number with all closed curves [33]. The topology then on the space of geodesic currents is given by its marked length spectrum. For the fixed surface  $S$ , denote by  $\mathcal{C}$  the set of isotopy classes of closed curves. The marked length spectrum of a geodesic current  $\mu$  is given by the collection  $\{i(\mu, \gamma)\}_{\gamma \in \mathcal{C}}$ . A sequence of geodesic currents  $\mu_n$  is said to converge to  $\mu$  if their marked length spectra converge; that is, for each  $\gamma \in \mathcal{C}$  and  $\epsilon > 0$ , there is an  $N(\epsilon, \gamma)$  such that for  $n > N(\epsilon, \gamma)$ , one has  $|i(\mu, \gamma) - i(\mu_n, \gamma)| < \epsilon$ . It is important to note that  $N$  is allowed to depend on the curve class chosen. No requirement on uniform convergence is required.

If a current arises from a metric, the following rather useful formula applies.

**Proposition 2.1** (Bonahon [4]; Otal [33]) *Let  $\mu$  be a current arising from a metric  $\sigma$ . Then*

$$i(\mu, \mu) = \frac{\pi}{2} \text{Area}(\sigma).$$

In the case where  $\mu$  is a geodesic current arising from a measured lamination, it is not hard to see that  $i(\mu, \mu) = 0$ , but in fact, this turns out to be a characterization of measured laminations.

**Proposition 2.2** (Bonahon [4]) *Let  $\mu$  be a geodesic current such that  $i(\mu, \mu) = 0$ . Then  $\mu$  is a measured lamination.*

It is clear that if  $\mu$  is a geodesic current, then so is  $c\mu$  for  $c \in \mathbb{R}_+$ . The set of projectivized currents, denoted by  $\text{PCurr}(S)$ , is given by  $\text{Curr}(S)/\sim$ , where  $\mu \sim \nu$  if there exists a positive constant  $c$  for which  $\mu = c\nu$ , and so consists of projective classes of geodesic currents. The space  $\text{PCurr}(S)$  is then given the quotient topology. We highlight an important property of this space.

**Proposition 2.3** (Bonahon [4]) *The space  $\text{PCurr}(S)$  is compact.*

Several geometric structures have been shown to be embedded into  $\text{Curr}(S)$ . The first such example was due to Bonahon [4], who showed Teichmüller space could be embedded inside  $\text{Curr}(S)$  via its Liouville current, namely  $\sigma \mapsto L_\sigma$  with the property that for any closed curve  $\gamma$ , one has  $l_\sigma([\gamma]) = i(L_\sigma, \gamma)$ , so that the length of the geodesic representative of  $\gamma$  with respect to the hyperbolic metric  $\sigma$  coincides with the intersection number between the currents  $L_\sigma$  and  $\gamma$ . As the space of measured laminations can be realized as geodesic currents, Bonahon recovers the Thurston compactification by way of projectivized geodesic currents.

Otal [33] has shown the space of negatively curved Riemannian metrics on surfaces can be realized by geodesic currents. For any simple curve class  $[\gamma]$ , the length of the unique geodesic representative coincides with the intersection number of the corresponding geodesic current and the curve class  $[\gamma]$ , extending the work of Bonahon.

Duchin, Leininger and Rafi [9] have embedded the space of singular flat metrics arising from integrable holomorphic quadratic differentials into the space of geodesic currents. We summarize a few results here, as we shall use them in what follows. Recall that to any holomorphic quadratic differential  $q$ , one can associate a singular flat metric  $|q|$  via canonical coordinates.

The unit sphere  $Q_g^1 \subset Q_g$  consists of the holomorphic quadratic differentials with  $L^1$ -norm one. Then the space  $\text{Flat}(S)$  of unit-norm singular flat metrics may be identified by

$$\text{Flat}(S) = Q_g^1 / \mathbb{S}^1,$$

where the action of  $\mathbb{S}^1$  is given by multiplication by  $e^{i\theta}$ , for  $0 \leq \theta \leq 2\pi$ . We require this quotient because if  $q$  is a holomorphic quadratic differential, then  $q$  and  $e^{i\theta}q$  will have the same singular flat metric  $|q|$ . For  $q \in Q_g^1$ , consider the transverse measure

for the vertical foliation of  $q$ , that is,  $v_q = |\operatorname{Re}(\sqrt{q})|$ . Denote by  $v_q^\theta = |\operatorname{Re}(e^{i\theta} \sqrt{q})|$  the vertical foliation of  $e^{i\theta}q$ . Form the integral

$$L_q := \frac{1}{2} \int_0^\pi v_q^\theta d\theta.$$

**Theorem 2.4** (Duchin, Leininger and Rafi [9]) *The integral  $L_q$  is a geodesic current such that to any simple closed curve  $\gamma$ ,*

$$l_{|q|}(\gamma) = i(L_q, \gamma),$$

where  $|q|$  is the singular flat metric arising from the holomorphic quadratic differential  $q$ . Furthermore, the map which sends  $|q| \in \operatorname{Flat}(S)$  to  $L_q \in \operatorname{PCurr}(S)$  is an embedding.

As a geodesic current is determined by its marked length spectrum, the construction of the geodesic current  $L_q$  depends only upon the  $U(1)$ -orbit of  $q$ . Hence we will use the notation  $L_{|q|}$  to denote the geodesic current whose marked length spectrum coincides with that of the singular flat metric  $|q|$ .

As the space of projectivized currents is compact, one may take the closure of the space  $\operatorname{Flat}(S)$ , and it is shown in [9] that the limiting structures consist precisely of projectivized mixed structures. A *mixed structure* may be defined as follows. Let  $S'$  be an incompressible subsurface of  $S$  equipped with a Riemann surface structure. Then consider  $Q_{S'}$ , the space of integrable meromorphic quadratic differentials on  $S'$  such that with respect to the underlying complex structure on  $S'$ , neighborhoods of boundary components of  $\partial S'$  are conformally punctured disks. To any such quadratic differential  $q$ , the corresponding singular flat metric on  $S'$  thus assigns length zero to any peripheral curve. Let  $\lambda$  be a measured lamination supported on the complement  $S \setminus S'$ . The triple  $(S', q, \lambda)$  is called a mixed structure on  $S$ . For any  $\eta = (S', q, \lambda)$ , one obtains a geodesic current  $L_\eta$  given by the property

$$i(L_\eta, \gamma) = i(\lambda, \gamma) + \frac{1}{2} \int_0^{\pi/2} i(v_q^\theta, \gamma) d\theta,$$

where  $\lambda$  is a closed curve on  $S$ . We remark that in the case  $S' = \emptyset$ , then  $\eta$  is a measured lamination on  $S$ , so that the space  $\operatorname{Mix}(S)$  properly contains  $\operatorname{ML}(S)$ . The compactification of the singular flat metrics arising from unit-norm quadratic differentials is then given by the following theorem.

**Theorem 2.5** (Duchin, Leininger and Rafi [9]) *The closure of  $\operatorname{Flat}(S)$  in  $\operatorname{PCurr}(S)$  is given by  $\operatorname{PMix}(S)$ .*

## 2.6 Anti-de Sitter space

We are primarily concerned with the anti-de Sitter space of signature  $(2, 1)$ , which is given by the quasisphere  $x_1^2 + x_2^2 - x_3^2 - x_4^2 = -1$  inside  $\mathbb{R}^{(2,2)}$  with the metric  $ds^2 = dx_1^2 + dx_2^2 - dx_3^2 - dx_4^2$ . More precisely,

$$\widehat{\text{AdS}}^3 = \{x \in \mathbb{R}^{(2,2)} : \langle x, x \rangle = -1\}.$$

As the manifold is pseudo-Riemannian, tangent vectors  $v \in T\widehat{\text{AdS}}^3$  come in one of the following three types:

- timelike if  $\langle v, v \rangle < 0$ ,
- lightlike if  $\langle v, v \rangle = 0$ ,
- spacelike if  $\langle v, v \rangle > 0$ .

The anti-de Sitter space  $\text{AdS}^3$  is given by the projectivization of  $\widehat{\text{AdS}}^3$ , its double cover. The isometry group of  $\text{AdS}^3$  is  $\text{PSL}(2, \mathbb{R}) \times \text{PSL}(2, \mathbb{R})$ .

A smooth surface  $S \hookrightarrow \text{AdS}^3$  is said to be *spacelike* if the restriction to  $S$  of the metric on  $\text{AdS}^3$  is a Riemannian metric. This is equivalent to the condition that every tangent vector  $v \in TS$  is spacelike.

Consider the Levi-Civita connections on  $S$  and  $\text{AdS}^3$  given by  $\nabla^S$  and  $\nabla$ , respectively. For a unit normal field  $N$  on  $S$ , the second fundamental form is given by

$$\nabla_{\tilde{v}} \tilde{w} = \nabla_v^S w + \text{II}(v, w)N,$$

where  $v$  and  $w$  are vector fields on  $S$ , and  $\tilde{v}$  and  $\tilde{w}$  are vector fields extending  $v$  and  $w$ . The shape operator is the  $(1, 1)$  tensor given by  $B(v) = \nabla_v N$ . It satisfies the property  $\text{II}(v, w) = \langle B(v), w \rangle$ . The maximal surfaces then are governed by the condition that  $\text{tr } B = 0$ .

An  $\text{AdS}^3$  manifold is a Lorentzian manifold locally isometric to  $\text{AdS}^3$ . Among these manifolds, we restrict our attention to those which are *globally hyperbolic maximal compact*, henceforth written as GHMC. These manifolds are defined by those satisfying the following three properties:

- (1) They contain a closed orientable spacelike surface  $S$ .
- (2) Each complete timelike geodesic intersects  $S$  precisely once.
- (3) They are maximal with respect to isometric embeddings.



It follows that GHMC  $\text{AdS}^3$  manifolds must be homeomorphic to  $S \times \mathbb{R}$ . Mess [28] showed that the genus of  $S$  must be at least two, and that GHMC structures are parametrized by two copies of Teichmüller space. Barbot, Béguin and Zeghib [2] showed that for each such GHMC manifold, there exists a unique embedded spacelike maximal surface  $\Sigma$ . In fact, there is a parametrization of all such GHMC manifolds by the unique embedded maximal surface it contains, along with its second fundamental form.

**Theorem 2.6** (Krasnov and Schlenker [22]) *Let  $M$  be a GHMC  $\text{AdS}^3$ -manifold and let  $\Sigma$  be its unique embedded spacelike maximal surface. The second fundamental form of  $\Sigma$  is given by the real part of a holomorphic quadratic differential on the underlying complex structure of the maximal surface. Furthermore, there is a homeomorphism between the space of all GHMC  $\text{AdS}^3$ -structures and the cotangent bundle of Teichmüller space, which assigns to a GHMC  $\text{AdS}^3$ -structure the conformal class of its unique maximal surface and the holomorphic quadratic differential for which its real part is the second fundamental form.*

The induced metric of the maximal surface is given by  $e^{2u}\sigma$ , where  $\sigma$  is the hyperbolic metric and  $u$  satisfies the PDE

$$\Delta_\sigma u = e^{2u} - e^{-2u}|\Phi|^2 - 1.$$

But the solution to this PDE is  $u = \frac{1}{2} \log \mathcal{H}$ , for which the PDE becomes the usual Bochner equation. Here  $\mathcal{H}$  is the holomorphic energy density arising from harmonic maps between closed hyperbolic surfaces. Hence, the induced metric of the maximal surface is given by  $\mathcal{H}\sigma$ . As a corollary of our main result, we will describe the limiting length spectrum of any sequence of induced metrics of the maximal surface.

### 3 Minimal lagrangians

A diffeomorphism  $\phi: (S, g_1) \rightarrow (S, g_2)$  is *minimal* if its graph  $\Sigma \subset (S \times S, g_1 \oplus g_2)$  with the induced metric is a minimal surface. Recall that  $\Sigma$  is a minimal surface if the inclusion  $i: \Sigma \rightarrow (S \times S, g_1 \oplus g_2)$  is critical point of the area functional. Observe that if  $\phi$  is minimal then so is  $\phi^{-1}$ . If  $\omega_1$  and  $\omega_2$  denote the area forms of  $g_1$  and  $g_2$ , respectively, and if in addition  $\Sigma \subset (S \times S, \omega_1 - \omega_2)$  is a lagrangian submanifold, then we say that  $\phi$  is a minimal lagrangian.

**Theorem 3.1** (Schoen [39]) *If  $g_1$  and  $g_2$  are hyperbolic metrics on  $S$ , then there is a unique minimal lagrangian map  $\phi: (S, g_1) \rightarrow (S, g_2)$  in the homotopy class of the identity.*

Let  $\Sigma$  denote the graph minimal surface with the induced metric. Then its inclusion into the product  $i: \Sigma \rightarrow (S \times S, g_1 \oplus g_2)$  is a conformal harmonic map. A conformal map to a product space is a product of harmonic maps whose Hopf differentials sum to zero. Hence, for any pair of points in Teichmüller space, one may record the data of both the conformal structure of the minimal surface along with one of the Hopf differentials. The harmonic-maps parametrization of Teichmüller space which we record below ensures the map is bijective. Sampson proved injectivity and continuity of the map, and Wolf showed the map was surjective and admits a continuous inverse.

**Theorem 3.2** (Sampson [38], Wolf [44]) *Let  $(S, \sigma)$  be a fixed hyperbolic surface. For any point in Teichmüller space  $[(S, \rho)]$ , select the representative  $(S, \rho)$  so that the identity map  $\text{id}: (S, \sigma) \rightarrow (S, \rho)$  is the unique harmonic map in its homotopy class, and denote its Hopf differential by  $\Phi(\rho)$ . Then this map*

$$\Phi: \mathcal{T}(S) \rightarrow H^0(X, K_X^2)$$

*is a homeomorphism, where  $X$  is the complex structure associated to  $(S, \sigma)$ .*

**Theorem 3.3** *There is a homeomorphism*

$$\Psi: \mathcal{T}(S) \times \mathcal{T}(S) \rightarrow \mathcal{Q}_g, \quad (X_1, X_2) \mapsto ([\Sigma], \text{Hopf}(u_1)),$$

*which assigns to any pair of points  $X_1, X_2$  in Teichmüller space the conformal structure of the unique graph minimal surface  $\Sigma \subset X_1 \times X_2$  along with the Hopf differential  $\text{Hopf}(u_1)$  of the projection  $u_1: \Sigma \rightarrow X_1$ .*

**Proof** The discussion above ensures the map  $\Psi$  is well-defined. As the construction of the minimal surface varies continuously with the choice of  $X_1$  and  $X_2$ , it is clear the map is continuous. To see injectivity of  $\Psi$ , suppose that  $\Psi(X_1, X_2) = \Psi(Y_1, Y_2) = (\Sigma, \Phi)$ . Then the harmonic maps  $u_1: \Sigma \rightarrow X_1$  and  $v_1: \Sigma \rightarrow Y_1$  have the same Hopf differentials, so by the harmonic-maps parametrization,  $X_1 = Y_1$ . The same argument forces  $X_2 = Y_2$ . Surjectivity follows similarly, as to any choice of Riemann surface  $\Sigma = (S, J)$  and holomorphic quadratic differential  $\Phi$ , there exists a unique hyperbolic metric  $X_1 = (S, g_1)$  such that the identity map  $\text{id}: \Sigma \rightarrow X_1$  is a harmonic map with Hopf differential  $\Phi$ . Similarly, one can find an  $X_2$  arising from the Hopf differential  $-\Phi$ .

Hence  $\Psi(X_1, X_2) = (\Sigma, \Phi)$ , which gives surjectivity. The inverse is clearly continuous as given the data of a Riemann surface and a holomorphic quadratic differential, the pair of hyperbolic metrics may be written explicitly and vary continuously, which suffices for the proof.  $\square$

## 4 Embedding of the induced metrics

In this section we study the induced metric on the graph minimal surfaces. Recall that given a pair  $(X_1, X_2)$  of hyperbolic surfaces, Theorem 3.1 produces a graph minimal surface  $\Sigma$  in the 4-manifold  $(S \times S, g_1 \oplus g_2)$ , where  $X_i = (S, g_i)$ . If  $m: (S, g_1) \rightarrow (S, g_2)$  is the unique minimal map isotopic to the identity, then  $\text{id}: (S, g_1) \rightarrow (S, m^*g_2)$  is the unique minimal map isotopic to the identity, which in this case is the identity map. The graph  $\Sigma$ , then, is the diagonal in  $S \times S$ , and there is a canonical diffeomorphism from  $S$  to the diagonal in  $S \times S$ . The induced metric on  $\Sigma$  thus furnishes a metric  $g$  on  $S$  by the pullback of this diffeomorphism. Henceforth, when we say *induced metric*, we refer to this metric  $g$  on  $S$ , and will use  $\Sigma$  to denote  $(S, g)$ . We consider these metrics up to pullback by a diffeomorphism isotopic to the identity, and call this subspace of metrics  $\text{Ind}(S)$  and endowing it with the compact-open topology. The remainder of the section is devoted towards studying geometric properties of the minimal surfaces and showing that  $\text{Ind}(S)$  can be embedded into  $\text{PCurr}(S)$ .

**Proposition 4.1** *Let  $X_1 = (S, g_1)$ ,  $X_2 = (S, g_2)$  and  $\Psi(X_1, X_2) = (\Sigma, \Phi)$ . Then the induced metric on the minimal surface  $\Sigma$  is given by  $g_1 + m^*g_2$ . Consequently, the induced metric is given by twice the  $(1, 1)$  part of a hyperbolic metric when expressed in conformal coordinates.*

**Proof** As in the discussion above, we may choose a suitable hyperbolic metric  $X_2 = (S, g_2)$  in the equivalence class of  $[X_2]$  to ensure that the unique minimal map isotopic to the identity is the identity map. Hence, the graph of the minimal map is the diagonal in  $S \times S$ , so that (after identifying the diagonal with  $S$ ) the harmonic map from the minimal surface  $\Sigma$  to  $X_i$  is given by the identity map. The first result then follows by definition of the product metric. Notice that the hyperbolic metric  $g_1$  may be written in conformal coordinates on  $\Sigma$  as  $\Phi dz^2 + \sigma e_1 dz d\bar{z} + \bar{\Phi} d\bar{z}^2$ . As the minimal surface  $\Sigma$  is mapped conformally into the product  $X_1 \times X_2$  of hyperbolic surfaces, then one obtains a pair  $u_i: \Sigma \rightarrow X_i$  of harmonic maps, whose Hopf differentials,  $\text{Hopf}(u_1)$  and  $\text{Hopf}(u_2)$ , sum to zero. Hence  $g_2$  may be written in conformal coordinates

on  $\Sigma$  as  $-\Phi dz^2 + \sigma e_2 dz d\bar{z} - \bar{\Phi} d\bar{z}^2$ , with  $|\Phi| = |-\Phi|$ , so by a result of Sampson (Proposition 4.4) the energy densities  $e_1$  and  $e_2$  will coincide. As the induced metric is given by the sum, the induced metric has local expression  $2\sigma e dz d\bar{z}$ .  $\square$

**Proposition 4.2** *The induced minimal surfaces have sectional curvature that is strictly negative.*

**Proof** For any point  $p \in \Sigma$ , it is clear that  $K_p \leq 0$ , since  $\Sigma$  is a minimal surface in an NPC space, so we wish to show that  $K_p \neq 0$ . The proof is by contradiction. Let  $\{e_1, e_2\}$  be an orthonormal basis of  $N_p \Sigma$ . Now consider the 2-plane spanned by eigenvectors  $X$  and  $Y$  of the second fundamental form  $\Pi$ . One has  $\Pi(X, Y) = \sum_{j=1}^2 \Pi_j(X, Y)e_j$ . The mean curvatures of the immersion are given by

$$(4-1) \quad \begin{aligned} H_1 &= \Pi_1(X, X) + \Pi_1(Y, Y) = 0, \\ H_2 &= \Pi_2(X, X) + \Pi_2(Y, Y) = 0. \end{aligned}$$

The Gauss equation tells us that at  $p$ ,

$$(4-2) \quad \begin{aligned} 0 &= \text{Rm}(X, Y, Y, X) \\ &= \widetilde{\text{Rm}}(X, Y, Y, X) - \langle \Pi(X, X), \Pi(Y, Y) \rangle + \langle \Pi(X, Y), \Pi(X, Y) \rangle \\ &= \widetilde{\text{Rm}}(X, Y, Y, X) + \sum_{j=1}^2 \Pi_j(X, X)\Pi_j(Y, Y) - \sum_{j=1}^2 \Pi_j(X, Y)^2, \end{aligned}$$

and as  $\mathbb{H}^2 \times \mathbb{H}^2$  is NPC, from (4-1) and (4-2) it follows that  $\Pi \equiv 0$  at  $p$  and that  $\widetilde{\text{Rm}}(X, Y, Y, X) = 0$  at  $p$ . As  $T(\mathbb{H}^2 \times \mathbb{H}^2) \cong T\mathbb{H}^2 \oplus T\mathbb{H}^2$ , we may write  $X = X_1 \oplus X_2$  and  $Y = Y_1 \oplus Y_2$ . A simple calculation shows

$$\begin{aligned} 0 &= \widetilde{\text{Rm}}(X, Y, Y, X) \\ &= \text{Rm}_1(X_1, Y_1, Y_1, X_1) + \text{Rm}_2(X_2, Y_2, Y_2, X_2) \\ &= \kappa(X_1, Y_1)(|X_1|^2|Y_1|^2 - \langle X_1, Y_1 \rangle^2) + \kappa(X_2, Y_2)(|X_2|^2|Y_2|^2 - \langle X_2, Y_2 \rangle^2) \\ &= -1 \cdot (|X_1|^2|Y_1|^2 - \langle X_1, Y_1 \rangle^2) - 1 \cdot (|X_2|^2|Y_2|^2 - \langle X_2, Y_2 \rangle^2), \end{aligned}$$

which by Cauchy–Schwarz implies that  $X_1$  and  $Y_1$  (and also  $X_2$  and  $Y_2$ ) are linearly dependent. So the map  $u_{1*}$  drops rank, a contradiction, as our surface was a graph.  $\square$

For a choice of complex coordinates  $z = x + iy$  on the minimal surface  $\Sigma$ , then  $\partial/\partial x$  and  $\partial/\partial y$  form an orthogonal frame. Denote then

$$E_1 = \left| \frac{\partial}{\partial x} \right|_{\Sigma}^{-1} \frac{\partial}{\partial x} \quad \text{and} \quad E_2 = \left| \frac{\partial}{\partial y} \right|_{\Sigma}^{-1} \frac{\partial}{\partial y}.$$

Let  $J$  be the almost complex structure on the 4-manifold  $X_1 \times X_2$ . Then  $J = J_1 \oplus J_2$ , where  $J_i$  is the almost complex structure arising from  $X_i = (S, g_i)$ .

**Proposition 4.3** *Let  $E_1, E_2$  and  $J$  be as above. The second fundamental form is given by*

$$\begin{aligned} \Pi(E_1, E_1) &= \frac{-\operatorname{Re} \Phi(\sigma e)_y - \sigma e(\operatorname{Im} \Phi)_x + \operatorname{Im} \Phi(\sigma e)_x}{\sigma e \sqrt{2\sigma e(\sigma^2 e^2 - 4|\Phi|^2)}} J E_1 \\ &\quad + \frac{\operatorname{Im} \Phi(\sigma e)_y - \sigma e(\operatorname{Re} \Phi)_x + \operatorname{Re} \Phi(\sigma e)_x}{\sigma e \sqrt{2\sigma e(\sigma^2 e^2 - 4|\Phi|^2)}} J E_2, \\ \Pi(E_2, E_2) &= \frac{\operatorname{Re} \Phi(\sigma e)_y + \sigma e(\operatorname{Im} \Phi)_x - \operatorname{Im} \Phi(\sigma e)_x}{\sigma e \sqrt{2\sigma e(\sigma^2 e^2 - 4|\Phi|^2)}} J E_1 \\ &\quad + \frac{-\operatorname{Im} \Phi(\sigma e)_y + \sigma e(\operatorname{Re} \Phi)_x - \operatorname{Re} \Phi(\sigma e)_x}{\sigma e \sqrt{2\sigma e(\sigma^2 e^2 - 4|\Phi|^2)}} J E_2, \\ \Pi(E_1, E_2) &= \frac{\operatorname{Im} \Phi(\sigma e)_y - \sigma e(\operatorname{Re} \Phi)_x + \operatorname{Re} \Phi(\sigma e)_x}{\sigma e \sqrt{2\sigma e(\sigma^2 e^2 - 4|\Phi|^2)}} J E_1 \\ &\quad + \frac{-\sigma e(\operatorname{Re} \Phi)_y + \operatorname{Re} \Phi(\sigma e)_y - \operatorname{Im} \Phi(\sigma e)_x}{\sigma e \sqrt{2\sigma e(\sigma^2 e^2 - 4|\Phi|^2)}} J E_2. \end{aligned}$$

**Proof** As  $\Sigma \subset X_1 \times X_2$  is a lagrangian submanifold,  $\{E_1, E_2, J E_1, J E_2\}$  forms an orthonormal basis of  $T(X_1 \times X_2) \cong T X_1 \oplus T X_2$  in this neighborhood. The second fundamental form then is given by

$$\Pi(X, Y) = \sum_{j=1}^2 \tilde{g}(\tilde{\nabla}_X Y, J E_j) J E_j,$$

where  $\tilde{g} = g_1 \oplus g_2$  and  $\tilde{\nabla} = \nabla_1 \oplus \nabla_2$ . We first calculate  $\Pi(E_1, E_1)$ . As the minimal surface metric is given by  $2\sigma e |dz|^2 = 2\sigma e (dx^2 + dy^2)$ , one has

$$2\sigma e(dx^2 + dy^2) \left( \frac{\partial}{\partial x}, \frac{\partial}{\partial x} \right) = 2\sigma e = \left\| \frac{\partial}{\partial x} \right\|_{\Sigma}^2,$$

so that

$$E_1 = \frac{1}{\sqrt{2\sigma e}} \frac{\partial}{\partial x}.$$

Similarly,  $E_2$  is given by

$$E_2 = \frac{1}{\sqrt{2\sigma e}} \frac{\partial}{\partial y}.$$

To calculate  $JE_1$ , we project  $E_1$  to each of its factors and apply the almost complex structure on each of its factors; namely, we find the vector which has the same length and forms angle  $\frac{\pi}{2}$  with the projected factor using the hyperbolic metric. This is the complex structure arising from the conformal class of the metric. To find  $J_1 E_1 = a(\partial/\partial x) + b(\partial/\partial y)$ , for instance, we observe first that the hyperbolic metric on  $X_1$  is given by

$$\begin{aligned}\rho_1 &= \Phi dz^2 + \sigma e dz d\bar{z} + \bar{\Phi} d\bar{z}^2 \\ &= (2 \operatorname{Re} \Phi + \sigma e) dx^2 - 4 \operatorname{Im} \Phi dx dy + (-2 \operatorname{Re} \Phi + \sigma e) dy^2.\end{aligned}$$

Hence we want to solve for  $a \neq 0$  and  $b > 0$  which satisfy

$$(4-3) \quad g_1\left(a \frac{\partial}{\partial x} + b \frac{\partial}{\partial y}, E_1\right) = 0,$$

$$(4-4) \quad g_1\left(a \frac{\partial}{\partial x} + b \frac{\partial}{\partial y}, a \frac{\partial}{\partial x} + b \frac{\partial}{\partial y}\right) = g_1(E_1, E_1) = \frac{2 \operatorname{Re} \Phi + \sigma e}{2\sigma e}.$$

Some basic algebra yields that

$$a = \frac{2 \operatorname{Im} \Phi}{\sqrt{(2\sigma e)((\sigma e)^2 - 4|\Phi|^2)}} \quad \text{and} \quad b = \frac{2 \operatorname{Re} \Phi + \sigma e}{\sqrt{(2\sigma e)((\sigma e)^2 - 4|\Phi|^2)}},$$

so that

$$J_1 E_1 = \frac{2 \operatorname{Im} \Phi}{\sqrt{(2\sigma e)((\sigma e)^2 - 4|\Phi|^2)}} \frac{\partial}{\partial x} + \frac{2 \operatorname{Re} \Phi + \sigma e}{\sqrt{(2\sigma e)((\sigma e)^2 - 4|\Phi|^2)}} \frac{\partial}{\partial y}.$$

Now  $J_2 E_1$  is found similarly, and is given by

$$J_2 E_1 = \frac{-2 \operatorname{Im} \Phi}{\sqrt{2\sigma e((\sigma e)^2 - 4|\Phi|^2)}} \frac{\partial}{\partial x} + \frac{-2 \operatorname{Re} \Phi + \sigma e}{\sqrt{2\sigma e((\sigma e)^2 - 4|\Phi|^2)}} \frac{\partial}{\partial y}.$$

The tangent vector given by  $\tilde{\nabla}_{E_1} E_1$  splits as  $\nabla_{E_1}^1 E_1 \oplus \nabla_{E_1}^2 E_1$ . The Christoffel symbols for  $g_1$  and  $g_2$  can be readily calculated:

$$\begin{aligned}\nabla_{E_1}^1 E_1 &= \nabla_{(1/\sqrt{2\sigma e})\partial/\partial x}^1 \frac{1}{\sqrt{2\sigma e}} \frac{\partial}{\partial x} \\ &= \frac{1}{\sqrt{2\sigma e}} \left( \frac{1}{\sqrt{2\sigma e}} \nabla_{\partial/\partial x}^1 \frac{\partial}{\partial x} + \left( \frac{1}{\sqrt{2\sigma e}} \right)_x \frac{\partial}{\partial x} \right) \\ &= \frac{1}{\sqrt{2\sigma e}} \left( \frac{1}{\sqrt{2\sigma e}} \left( {}^1\Gamma_{11}^1 \frac{\partial}{\partial x} + {}^1\Gamma_{11}^2 \frac{\partial}{\partial y} \right) + \left( \frac{1}{\sqrt{2\sigma e}} \right)_x \frac{\partial}{\partial x} \right) \\ &= \left( \frac{1}{2\sigma e} {}^1\Gamma_{11}^1 + \frac{1}{\sqrt{2\sigma e}} \left( \frac{1}{\sqrt{2\sigma e}} \right)_x \right) \frac{\partial}{\partial x} + \frac{1}{2\sigma e} {}^2\Gamma_{11}^2 \frac{\partial}{\partial y},\end{aligned}$$

where  ${}^1\Gamma_{11}^1$  and  ${}^1\Gamma_{11}^2$  are the usual Christoffel symbols, with the extra superscript denoting that these are the ones for the metric  $g_1$ . They are given explicitly by

$$\begin{aligned}
 {}^1\Gamma_{11}^1 &= \frac{1}{2} \left( \frac{-2 \operatorname{Re} \Phi + \sigma e}{\sigma^2 e^2 - 4|\Phi|^2} (2 \operatorname{Re} \Phi + \sigma e)_x \right. \\
 &\quad \left. + \frac{2 \operatorname{Im} \Phi}{\sigma^2 e^2 - 4|\Phi|^2} ((-4 \operatorname{Im} \Phi_x) - (2 \operatorname{Re} \Phi + \sigma e)_y) \right), \\
 {}^2\Gamma_{11}^1 &= \frac{1}{2} \left( \frac{2 \operatorname{Im} \Phi}{\sigma^2 e^2 - 4|\Phi|^2} (2 \operatorname{Re} \Phi + \sigma e)_x \right. \\
 &\quad \left. + \frac{2 \operatorname{Re} \Phi + \sigma e}{\sigma^2 e^2 - 4|\Phi|^2} ((-4 \operatorname{Im} \Phi_x) - (2 \operatorname{Re} \Phi + \sigma e)_y) \right).
 \end{aligned}$$

Similarly, the same can be done for the metric  $g_2$  and using the formula for  $\Pi$ , one gets  $\Pi(E_1, E_1)$ . The same can be done for the rest. □

It would be curious to see under what conditions different points in  $Q_g$  would yield the same induced metric. One might hope that the space of induced metrics would be homeomorphic to  $Q_g$ , but the following result of Sampson shows this is not possible.

**Proposition 4.4** (Sampson) *For a fixed closed hyperbolic surface  $X = (S, \sigma)$ , if  $\Phi_1$  and  $\Phi_2$  are two Hopf differentials on  $X$  arising from harmonic maps from  $X$  to closed hyperbolic surfaces of the same genus such that the norms  $|\Phi_1|$  and  $|\Phi_2|$  coincide, then the energy densities coincide, that is,  $e_1 = e_2$ .*

Hence, if we select two elements of  $Q_g$ , say  $(X, \Phi_1)$  and  $(X, \Phi_2)$ , where  $|\Phi_1| = |\Phi_2|$  but  $\Phi_1 \neq \Phi_2$ , then the corresponding energy densities are the same and hence the corresponding induced metrics are the same.

The following proposition is a converse to the result of Sampson and shows this is the only situation for which the corresponding induced metrics coincide.

**Lemma 4.5** *On a fixed closed hyperbolic surface, we have  $e_1 = e_2$  if and only if  $|\Phi_1| = |\Phi_2|$ .*

**Proof** That  $|\Phi_1| = |\Phi_2|$  implies  $e_1 = e_2$  is due to Sampson. Now suppose  $e_1 = e_2$ . Then  $\mathcal{H}_1 + \mathcal{L}_1 = \mathcal{H}_2 + \mathcal{L}_2$ , so the Bochner formula  $\Delta \log \mathcal{H}_i = 2\mathcal{H}_i - 2\mathcal{L}_i - 2$  may be rewritten as  $\Delta \log \mathcal{H}_i = 4\mathcal{H}_i - 2e_i - 2$ . Subtracting the two equations for  $i = 1, 2$  yields

$$\Delta \log \frac{\mathcal{H}_1}{\mathcal{H}_2} = 4(\mathcal{H}_1 - \mathcal{H}_2).$$

Now  $\mathcal{H}_i > 0$ , so that the quotient  $\mathcal{H}_1/\mathcal{H}_2$  attains its maximum on the surface; we claim this is 1, for if the maximum of  $\mathcal{H}_1/\mathcal{H}_2$  were greater than 1, then at the maximum (which is also the maximum of  $\log(\mathcal{H}_1/\mathcal{H}_2)$ ) we would have

$$0 \geq \Delta \log \frac{\mathcal{H}_1}{\mathcal{H}_2} = 4(\mathcal{H}_1 - \mathcal{H}_2) = 4\mathcal{H}_2 \left( \frac{\mathcal{H}_1}{\mathcal{H}_2} - 1 \right) > 0,$$

a contradiction, so that  $\mathcal{H}_1/\mathcal{H}_2 \leq 1$  and symmetrically  $\mathcal{H}_2/\mathcal{H}_1 \leq 1$ . Hence  $\mathcal{H}_1 = \mathcal{H}_2$  and so  $\mathcal{L}_1 = \mathcal{L}_2$ , by the assumption on the energy densities. From the formula  $|\Phi|^2/\sigma^2 = \mathcal{H}\mathcal{L}$ , the conclusion follows.  $\square$

**Corollary 4.6** *The space of induced metrics  $\text{Ind}(S)$  may be identified with  $Q_g/\sim$ , where  $(X, \Phi_1) \sim (Y, \Phi_2)$  if  $X = Y$  and  $|\Phi_1| = |\Phi_2|$ .*

We conclude this section by proving that the space  $\text{Ind}(S)$  can be embedded into the space of currents, and that the embedding remains injective after projectivization, thereby obtaining an embedding into projectivized currents.

**Proposition 4.7** *The space  $\text{Ind}(S)$  can be realized as geodesic currents.*

**Proof** From Proposition 4.2, the induced metrics have strictly negative curvature, so by Otal [33], there is a well-defined embedding  $\mathcal{C}: \text{Ind}(S) \rightarrow \text{Curr}(S)$  from the space of induced metrics on  $S$  to the space of geodesic currents, which sends  $2\sigma e \mapsto L_{2\sigma e}$ , so that if  $\gamma$  is a closed curve, then  $l_{2\sigma e}([\gamma]) = i(L_{2\sigma e}, \gamma)$ .  $\square$

The following lemma is a statement concerning energy densities and their failure to scale linearly.

**Lemma 4.8** *On a fixed closed hyperbolic surface, if  $e_1 = ce_2$ , then  $c = 1$ , and hence  $|\Phi_1| = |\Phi_2|$ .*

**Proof** Without loss of generality, suppose  $c \geq 1$ , else we may re-index so that  $c \geq 1$ . Then  $\mathcal{H}_1/\mathcal{H}_2 \leq c$ , for if  $\mathcal{H}_1/\mathcal{H}_2 > c$ , we locate the maximum of  $\mathcal{H}_1/\mathcal{H}_2$ , and the Bochner formula at that point yields

$$\begin{aligned} 0 \geq \Delta \log \frac{\mathcal{H}_1}{\mathcal{H}_2} &= 4(\mathcal{H}_1 - \mathcal{H}_2) - 2(e_1 - e_2) = 4(\mathcal{H}_1 - \mathcal{H}_2) - 2(ce_2 - e_2) \\ &= 4\mathcal{H}_2 \left( \frac{\mathcal{H}_1}{\mathcal{H}_2} - 1 \right) - 2e_2(c - 1) \\ &> 4\mathcal{H}_2(c - 1) - 2e_2(c - 1) \\ &= (c - 1)(4\mathcal{H}_2 - 2e_2) = (c - 1)(2\mathcal{H}_2 - 2\mathcal{L}_2) = 2(c - 1)\mathcal{J}_2 > 0, \end{aligned}$$



a contradiction. Notice the upper bound is actually attained, for at a zero of  $|\Phi_1|$ , we have that  $\mathcal{L}_1$  vanishes and so at such a zero we have the equation

$$\mathcal{H}_1 = c\mathcal{H}_2 + c\mathcal{L}_2,$$

and as we have  $\mathcal{H}_1/\mathcal{H}_2 \leq c$ , it follows that  $\mathcal{L}_2$  must also vanish whenever  $\mathcal{L}_1$  does. In fact, we can say more about the zeros of  $\mathcal{L}_i$ . The condition on the energy densities yields the equality

$$0 = (c\mathcal{H}_2 - \mathcal{H}_1) + (c\mathcal{L}_2 - \mathcal{L}_1),$$

and the bound on the quotient  $\mathcal{H}_1/\mathcal{H}_2$  implies that the first term is nonnegative so the second term is nonpositive, that is,  $c\mathcal{L}_2 - \mathcal{L}_1 \leq 0$  or  $c \leq \mathcal{L}_1/\mathcal{L}_2$  or  $\mathcal{L}_2/\mathcal{L}_1 \leq 1/c$ , so that the order of the zeros of  $\mathcal{L}_2$  is greater than or equal to the order of zeros of  $\mathcal{L}_1$ . As  $|\Phi|^2/\sigma^2 = \mathcal{H}\mathcal{L}$  and  $\mathcal{H} > 0$ , both  $\mathcal{L}_1$  and  $\mathcal{L}_2$  have exactly  $8g - 8$  zeros counted with multiplicity, so the order of vanishing of  $\mathcal{L}_1$  is the same as that of  $\mathcal{L}_2$  at every point of the surface. Hence the quadratic differentials  $\Phi_1$  and  $\Phi_2$  differ by a multiplicative constant  $k \in \mathbb{C}$ , that is,  $\Phi_1 = k\Phi_2$ . At the zero of  $|\Phi_2|$  (and so also a zero of  $|\Phi_1|$ ), which is a maximum of the quotient  $\mathcal{H}_1/\mathcal{H}_2$ , the Bochner equation now reads

$$0 \geq \Delta \log \frac{\mathcal{H}_1}{\mathcal{H}_2} = 2\mathcal{H}_1 - \frac{2|\Phi_1|^2}{\sigma^2\mathcal{H}_1} - 2\mathcal{H}_2 + \frac{2|\Phi_2|^2}{\sigma^2\mathcal{H}_2} = 2(\mathcal{H}_1 - \mathcal{H}_2) = 2\mathcal{H}_2(c - 1) \geq 0,$$

which implies  $c = 1$ , and by the previous lemma  $|k| = 1$ . □

**Theorem 4.9** *The space of induced metrics  $\text{Ind}(S)$  embeds into  $\text{PCurr}(S)$ .*

**Proof** Let  $\pi : \text{Curr}(S) \rightarrow \text{PCurr}(S)$  be the natural projection map. It suffices to show that the map  $\pi \circ \mathcal{C} : \text{Ind}(S) \rightarrow \text{PCurr}(S)$  is injective. If the images of two induced metrics under the map  $\pi \circ \mathcal{C}$  coincide, then by Otal’s theorem [33] on the marked length spectrum rigidity of negatively curved Riemannian metrics, we have

$$\sigma dz d\bar{z} = c\sigma' e' dz d\bar{z},$$

where  $c \in \mathbb{R}_{>0}$ . Then they will be in the same conformal class, so that  $\sigma = \sigma'$ . Then  $e = ce'$ , and by Lemma 4.8,  $c = 1$ . □

**Remark** As the induced metrics are not scalar multiples of each other, we make a slight modification by dividing the induced metrics by 2 to ensure these metrics are now precisely the  $(1, 1)$ -part of a hyperbolic metric when written in conformal coordinates, rather than twice that.

## 5 Compactification of the induced metrics

In this section we identify the elements in the closure  $\overline{\text{Ind}(S)} \subset \text{PCurr}(S)$ . As the space of projectivized currents is compact, we obtain a compactification  $\text{Ind}(S) \sqcup \text{PMix}(S)$  of the induced metrics from the embedding obtained in the previous section.

### 5.1 Flat metrics as limits

In a simple scenario where the conformal structure of the minimal surface remains fixed, we can describe the asymptotic behavior of the induced metric. We consider the simplest case, where  $X_{1,n}$  (and consequently  $X_{2,n}$ ) lie along a harmonic-maps ray, that is, the sequence of Hopf differentials of the projection map onto the first factor is given by  $t_n\Phi$ , where  $\Phi \neq 0$  and  $t_n \rightarrow \infty$ .

**Proposition 5.1** *Let  $\sigma_n e_n$  be the induced metric where  $\sigma_n = \sigma$  for all  $n$ , and the Hopf differentials of the harmonic maps  $u_{1,n}: (S, \sigma) \rightarrow X_{1,n}$  are given by  $t_n\Phi_0$ , where  $\Phi_0$  is a unit-norm quadratic differential on  $(S, \sigma)$ . Suppose  $\mathcal{E}_n \rightarrow \infty$ . Then everywhere away from the zeros of  $|\Phi_0|$ , one has*

$$\lim_{n \rightarrow \infty} \frac{\sigma_n e_n}{\mathcal{E}_n} = |\Phi_0|.$$

**Proof** By construction, the Hopf differential of the harmonic map from  $(S, \sigma)$  to  $X_{1,n}$  is given by  $t_n\Phi_0$ , where  $\Phi_0$  is a unit-norm quadratic differential. In a neighborhood away from any zero of  $\Phi_0$ , consider then the horizontal foliation of  $\Phi_n = t_n\Phi_0$ . By the estimates on the geodesic curvature of its image [45], a horizontal arc of the foliation in this neighborhood will be mapped close to a geodesic in  $X_{1,n}$ ; we do not reproduce the techniques here, as we will do so later in a slightly modified setting. Using normal coordinates  $(x, y)$  for the target adapted to this geodesic and estimates on stretching [44], we have that

$$(x, y) \mapsto (2t_n^{1/2}x, 0) + o(e^{-ct}),$$

where the constant  $c$  only depends upon the domain Riemann surface and the distance from the zero of the quadratic differential. For the harmonic map from  $(S, \sigma)$  to  $X_{2,n}$ , its Hopf differential is given by  $-t_n\Phi_0$ , so that an arc of its horizontal foliation, which is an arc of the vertical foliation of  $t_n\Phi_0$ , gets mapped close to a geodesic, yielding

$$(x, y) \mapsto (0, 2t_n^{1/2}y) + o(e^{-ct}).$$

Hence, as a map from  $\Sigma$  to the 4-manifold  $X_{1,n} \times X_{2,n}$  with the product metric, we have that the induced metric  $\sigma_n e_n$  in this neighborhood has the form

$$(4t_n + o(e^{-ct})) dx^2 + 2o(e^{-ct}) dx dy + (4t_n + o(e^{-ct})) dy^2.$$

Dividing by  $4t_n$  and observing that for a high-energy harmonic map, the total energy is comparable to twice the  $L^1$ -norm of the quadratic differential (Proposition 5.8), and taking the limit, yields the conclusion.  $\square$

**Proposition 5.2** *Suppose  $\sigma_n e_n$  is a sequence of induced metrics such that  $\sigma_n \rightarrow \sigma$  in  $\mathcal{T}(S)$  and  $\mathcal{E}_n \rightarrow \infty$ . Then, after passing to a subsequence, there exists a sequence  $t_n$  and a unit-norm quadratic differential  $\Phi_0$  on  $[\sigma]$  such that*

$$\lim_{n \rightarrow \infty} \frac{\sigma_n e_n}{t_n} \rightarrow |\Phi_0|.$$

**Proof** Let  $t_n = \mathcal{E}_n$ . Then the result follows from the compactness of unit-norm holomorphic quadratic differentials over a compact set in  $\text{Teich}(S)$ , and the argument in the previous proposition.  $\square$

As the previous results only show  $C^0$  convergence in any neighborhood away from a zero of the quadratic differential, it is not quite so obvious we have convergence in the sense of length spectrum. The following technical proposition shows we actually do have convergence when the metrics are regarded as projectivized geodesic currents. With the length spectrum embedding (as given in Theorem 4.9), we now have sequences of points whose limits are the flat structures in the space of geodesic currents.

**Proposition 5.3** *Let  $\sigma_n e_n$  and  $\mathcal{E}_n$  be in the same setting as above. Then, as currents,*

$$\frac{L_{\sigma_n e_n}}{\mathcal{E}_n^{1/2}} \rightarrow L_{|\Phi_0|}.$$

**Proof** As the topology of geodesic currents is determined by the intersection number against closed curves, it suffices to show that given any closed, nonnull homotopic curve class  $[\gamma]$  and  $\epsilon > 0$ , there is an  $N([\gamma], \epsilon)$  such that for  $n > N$ , one has that  $|i(L_{\sigma_n e_n / \mathcal{E}_n}, \gamma) - i(L_{|\Phi_0|}, \gamma)| < \epsilon$ . We choose a representative  $\gamma$  of  $[\gamma]$  to be a  $|\Phi_0|$ -geodesic with length  $L = i(L_{|\Phi_0|}, \gamma)$  with some fixed orientation. As the estimate in Proposition 5.2 does not hold near a zero  $z_i$  of  $|\Phi_0|$ , the first step is to construct open balls  $V_i$  of radius  $\epsilon$  in the  $|\Phi_0|$ -metric about each zero  $z_i$  of  $\Phi_0$  (choosing  $\epsilon$  sufficiently

small) so that

- (i) balls centered about distinct zeros do not intersect,
- (ii) if the curve  $\gamma$  enters one of the neighborhoods  $V_i$ , then the curve  $\gamma$  must intersect the zero  $z_i$  before  $\gamma$  exits  $V_i$ ,
- (iii)  $(1 - \epsilon)C - (4g - 2)\pi\epsilon > 0$ , where  $C$  is the systolic length of the surface  $(S, |\Phi_0|)$ .

As  $\Phi_0$  is holomorphic, the zeros are isolated, so we can easily ensure that (i) is satisfied. If the curve  $\gamma$  does not intersect  $z_i$ , then as  $\gamma$  is a closed curve, the distance from  $z_i$  to the curve  $\gamma$  in the  $|\Phi_0|$ -metric is bounded away from zero, guaranteeing condition (ii). Finally, condition (iii) follows as the systolic length  $C$  of  $(S, |\Phi_0|)$  and the genus of surface are fixed.

As the complement of the union of the  $V_i$  forms a compact set, by Proposition 5.2 we can find an  $N$  so that for  $n > N$  the metrics  $\sigma_n e_n / \mathcal{E}_n$  and  $|\Phi_0|$  differ by at most  $\epsilon$ . Now each time  $\gamma$  enters  $V_i$ , say at  $p$ , then hits the zero  $z_i$  and exits  $V_i$  for the first time thereafter, say at  $q$ , we may replace that segment of  $\gamma$  with a segment running along the boundary of  $V_i$  connecting  $p$  and  $q$ . Notice that this does not change the homotopy class of  $\gamma$ . We make this alteration for each instance  $\gamma$  enters a  $V_i$ , and denote the new curve by  $\gamma'$ . Observe that each time we make such an alteration, the length of the curve (in the  $|\Phi_0|$ -metric) increases by at most  $K_i\epsilon$ , where  $K_i$  is a constant depending only upon the  $|\Phi_0|$  and the order of the zero  $z_i$ . In fact  $K_i \leq (4g - 2)\pi$ . Hence the  $|\Phi_0|$ -length of  $\gamma'$  is bounded above by  $L + \sum_{i=1}^j n_i K_i \epsilon$ , where  $n_i$  is the number of times  $\gamma$  enters  $V_i$ . But as  $\gamma'$  now lies in the complement of the union of the  $V_i$ , by Proposition 5.2, the length of  $\gamma'$  in the  $\sigma_n e_n / \mathcal{E}_n$ -metric is at most  $(1 + \epsilon)(L + \sum_{i=1}^j n_i K_i \epsilon)$ . But the length of  $\gamma'$  in the  $\sigma_n e_n / \mathcal{E}_n$ -metric must be at least the length of the geodesic in its homotopy class, which has length  $L'_n = i(L_{\sigma_n e_n / \mathcal{E}_n}, \gamma)$ ; hence

$$(1 + \epsilon) \left( L + \sum_{i=1}^j n_i K_i \epsilon \right) \geq L'_n.$$

Distributing on the left-hand side and subtracting both sides by  $L$  yields

$$\sum_{i=1}^j n_i K_i \epsilon + \epsilon \left( L + \sum_{i=1}^j n_i K_i \epsilon \right) \geq L'_n - L := i(L_{\sigma_n e_n / \mathcal{E}_n}, \gamma) - i(L_{|\Phi_0|}, \gamma).$$

Now if  $L'_n - L \geq 0$ , we are done, for  $K_i$  is independent of  $\epsilon$  and  $n_i$  is constant in  $\epsilon$ .

So consider the case where  $L'_n - L < 0$ , that is,  $L > L'_n$ . Consider the  $\sigma_n e_n / \mathcal{E}_n$ -geodesic  $\tilde{\gamma}_n$  in the homotopy class of  $\gamma$ , and again we give  $\tilde{\gamma}_n$  an orientation. Naturally  $\tilde{\gamma}_n$  can enter and exit the  $V_i$  neighborhoods multiple times, but we remark that as the distance function on a NPC space from a convex set is itself convex, then each time the curve leaves  $V_i$ , it must pick up some topology before returning, that is, the part of the curve rel endpoints lying on the boundary of  $V_i$  is not homotopic to a segment along the boundary of  $V_i$ .

However, now if  $\tilde{\gamma}$  enters and exits  $V_i$  say a total of  $r$  times, we consider the pairs of entry and exit points ordered accordingly as  $p_1, q_1, \dots, p_r, q_r$  using the chosen orientation. Now look at the segment of  $\tilde{\gamma}_n$  between  $p_s$  and  $p_{s+1}$ . If this is homotopic rel endpoints to a segment of the boundary of  $V_i$ , then we look at the segment of  $\tilde{\gamma}_n$  between  $p_s$  and  $p_{s+2}$  (using a cyclic ordering, so  $r + 1$  is identified with 1) and see if that segment is homotopic relative endpoints to a segment along the boundary of  $V_i$ . We repeat this until the segment of  $\tilde{\gamma}_n$  between  $p_s$  and  $p_{s'}$  is not homotopic rel endpoints to the boundary of  $V_i$ . Then we repeat this process for  $p_s$  and  $p_{s-1}$  (again using a cyclic ordering) until we find the segment of  $\tilde{\gamma}_n$  between  $p_s$  and  $p_{s''}$  which is not homotopic rel endpoints to the boundary of  $V_i$ . Then we replace the segment of  $\tilde{\gamma}$  between  $p_{s''+1}$  and  $p_{s'-1}$  with a segment along the boundary of  $V_i$  connecting these two points. We repeat this for each  $i$ , so that when the curve leaves  $V_i$ , it picks up some topology before reentering  $V_i$ . Altering  $\tilde{\gamma}_n$  in this fashion yields a curve  $\tilde{\gamma}'_n$  lying outside of all the  $V_i$ . Switching over to the  $|\Phi_0|$ -metric yields the inequality

$$(1 + \epsilon)L'_n + \sum_{i=1}^{4g-4} m_i K_i \epsilon \geq L,$$

where  $m_i$  is the number of segments of the altered curve  $\tilde{\gamma}'_n$  lying on the boundary of  $V_i$ , and once again  $K_i$  is a constant depending solely on the order of the zero  $z_i$ . By the assumption that  $L > L'_n$ , we have actually that

$$L'_n + \epsilon L + \sum_{i=1}^{4g-4} m_i K_i \epsilon \geq L, \quad \text{so} \quad \epsilon L + \sum_{i=1}^{4g-4} m_i K_i \epsilon \geq L - L'_n.$$

It suffices to show that  $m_i$  can be bounded independently of  $n$ . This follows from an estimate on the systolic length of the metric  $\sigma e_n / \mathcal{E}_n$ . Let  $C'$  denote the systolic length among all homotopically nontrivial curves which avoid the  $V_i$  for the metric  $|\Phi|$ . Then  $C' \geq C$ . Then by Proposition 5.1, the systolic length among all homotopically nontrivial curves which avoid all the  $V_i$  for the metric  $\sigma e_n / \mathcal{E}_n$  is at least  $(1 - \epsilon)C'$ .

If  $K$  denotes the largest constant among the  $K_i$ , then one has that

$$\sum_{i=1}^{4g-4} m_i \leq \frac{L}{(1-\epsilon)C - K\epsilon},$$

for by construction we had  $m_i$  segments of  $\tilde{\gamma}'_n$  each of which is not homotopic rel endpoints to the boundary of  $V_i$ , so that if we connect the endpoints of the segment with a segment along the boundary of  $V_i$ , we add at most  $K\epsilon$  to the length of the segment. But we now have a closed curve not homotopic to the boundary of any of the  $V_i$ , so the length of this closed curve is bigger than  $C'$ . This suffices for the proof.  $\square$

The resulting flat metrics arising from unit-norm holomorphic quadratic differentials are distinct as Riemannian metrics from the induced metrics as the quadratic differential metrics have zero curvature away from the zeros, whereas the induced metrics have negative curvature everywhere (Proposition 4.2). In fact, the flat metrics are distinct as geodesic currents, as work of Frazier [13] shows that the marked length spectrum distinguishes nonpositively curved Euclidean metrics from the negatively curved Riemannian metrics.

## 5.2 Measured laminations as limits

However, not all limits of induced metrics are given by flat metrics. One can also obtain measured laminations. This is most readily seen in the setting where one takes a hyperbolic metric and looks at the minimal lagrangian to itself. The induced metric of the minimal surface is then twice the hyperbolic metric. We thus have a copy of Teichmüller space inside the space of induced metrics inside the space of projectivized currents. From Bonahon [4], we know we must have projectivized measured laminations in our compactification of the induced metrics. However, there are more ways to obtain measured laminations than by degenerating only the induced metrics which are scalar multiples of hyperbolic metrics, as the following proposition shows.

**Proposition 5.4** *Suppose that  $L_{\sigma_n e_n}$  leaves all compact sets, but that the sequence  $\mathcal{E}_n$  of total energies is bounded. Then, in  $\text{PCurr}(S)$ , we have  $[L_{\sigma_n e_n}] \rightarrow [\lambda] \in \text{PMF}(S)$ . Furthermore, if  $[L_{\sigma_n}] \rightarrow [\lambda']$  in the Thurston compactification, then  $i(\lambda, \lambda') = 0$ , where  $\lambda \in [\lambda]$  and  $\lambda' \in [\lambda']$ .*

**Proof** By the compactness of  $\text{PCurr}(S)$ , any sequence  $[L_{\sigma_n e_n}]$  subconverges to  $[\lambda] \in \text{PCurr}(S)$ . Hence, there is a sequence of positive real numbers so that  $t_n L_{\sigma_n e_n} \rightarrow \lambda \in \text{Curr}(S)$ . We claim  $t_n \rightarrow 0$ .

Consider a finite set of curves  $\gamma_1, \gamma_2, \dots, \gamma_k$  which fill the surface  $S$ . Then the current  $\gamma_1 + \gamma_2 + \dots + \gamma_k$  is a *binding current*, that is to say, it has positive intersection number with any nonzero geodesic current.

As  $L_{\sigma_n e_n}$  leaves all compact sets in  $\text{Curr}(S)$ ,

$$\lim_{n \rightarrow \infty} i(L_{\sigma_n e_n}, \gamma_1 + \dots + \gamma_k) \rightarrow \infty,$$

so by continuity of the intersection form, one has

$$\lim_{n \rightarrow \infty} t_n i(L_{\sigma_n e_n}, \gamma_1 + \dots + \gamma_k) = i(\lambda, \gamma_1 + \dots + \gamma_k).$$

But the intersection number on the right-hand side is finite, hence  $t_n \rightarrow 0$ . From Proposition 2.1, one has  $i(L_{\sigma_n e_n}, L_{\sigma_n e_n}) = \frac{\pi}{2} \text{Area}(S, \sigma_n e_n)$ , which in this case is  $\frac{\pi}{2} \mathcal{E}_n$ . Then

$$i(\lambda, \lambda) = \lim_{n \rightarrow \infty} i(t_n L_{\sigma_n e_n}, t_n L_{\sigma_n e_n}) = \lim_{n \rightarrow \infty} t_n^2 \frac{\pi}{2} \mathcal{E}_n = 0,$$

where the last equality follows from the boundedness of total energy, hence  $\lambda \in \text{MF}(S)$ . Now if  $[L_{\sigma_n}] \rightarrow [\lambda']$ , then there is a sequence  $t'_n \rightarrow 0$  such that  $t'_n L_{\sigma_n} \rightarrow \lambda'$ . Then

$$i(\lambda, \lambda') = \lim_{n \rightarrow \infty} i(t_n L_{\sigma_n e_n}, t'_n L_{\sigma_n}) \leq \lim_{n \rightarrow \infty} t_n t'_n i(L_{\sigma_n e_n}, L_{\sigma_n e_n}) = \lim_{n \rightarrow \infty} t_n t'_n \mathcal{E}_n = 0,$$

where the inequality follows from  $\sigma_n \leq \sigma_n e_n$  as metrics, and the last equality by the boundedness of the sequence of total energy  $\mathcal{E}_n$  along with the sequences  $t_n, t'_n$  tending towards zero. □

### 5.3 Mixed structures as limits

As some of the possible limits are the singular flat metrics arising from a holomorphic quadratic differential, the closure of the space of induced metrics on the minimal surface must include mixed structures, as these arise as limits of singular flat metrics. The main theorem asserts these are precisely all the possible limits of the degenerating minimal surfaces.

**Theorem 5.5** *Let  $\sigma_n e_n$  be a sequence of induced metrics such that  $\sigma_n$  leaves all compact sets in  $\mathcal{T}(S)$  or  $\mathcal{E}_n \rightarrow \infty$ . Then there exists a sequence  $t_n \rightarrow 0$  such that, up to a subsequence, we have  $t_n L_{\sigma_n e_n} \rightarrow \eta = (S', q, \lambda) \in \text{Mix}(S) \subset \text{Curr}(S)$ . Furthermore, given any  $\eta \in \text{Mix}(S)$ , there exists a sequence of induced metrics  $\sigma_n e_n$ , and a sequence of constants  $t_n \rightarrow 0$ , such that  $t_n L_{\sigma_n e_n} \rightarrow \eta$ . Hence, the closure of the space of induced metrics in the space of projectivized currents is  $\overline{\text{Ind}(S)} = \text{Ind}(S) \sqcup \text{PMix}(S)$ .*

The proof of the main theorem will follow from a series of intermediate results, and will be at the end of the section. The strategy is to show that if the sequence of currents coming from the induced metrics is not converging projectively to a measured lamination, then scaling the induced metrics to have total area 1 is enough to ensure convergence in length spectrum. To each normalized induced metric, we produce a quadratic differential metric in the same conformal class as the induced metric, which will serve as a lower bound. Convergence of the quadratic differential metric to a mixed structure will yield a decomposition of the surface into a flat part and a laminar part. On each flat part, we will prove the conformal factor between the normalized induced metric and the quadratic differential converges to 1 uniformly (away from finitely many points). An area argument will show the complement is laminar.

The following proposition allows us to analyze sequences of induced metrics which are not converging to projectivized measured laminations. If the sequence of induced metrics is not converging to a projectivized measured lamination, we may scale the current associated to the induced metric by the square root of its area (which is also the total energy). We remark that in the case where the limiting geodesic current is not a measured lamination, scaling the induced metrics by total energy of the associated harmonic map is strong enough to ensure length-spectrum convergence, yet delicate enough to ensure the limiting length spectrum is not identically zero. This should be compared to the situation in [45; 8], where one always scales the metric by the total energy.

**Proposition 5.6** *Suppose the conformal class of the minimal surface leaves all compact sets in  $\mathcal{T}(S)$ , and the sequence of total energy is unbounded, that is,  $\mathcal{E}_n \rightarrow \infty$ . Then, up to a subsequence, there exists a sequence  $c_n \rightarrow 0$  and a geodesic current  $\mu$  such that  $c_n L_{\sigma_n e_n} \rightarrow \mu$ . If  $\mu$  is a measured lamination, then  $c_n = o(\mathcal{E}_n^{-1/2})$ . If  $\mu$  is not a measured lamination, then  $c_n \asymp \mathcal{E}_n^{-1/2}$ .*

**Proof** By Theorem 4.9, one has an embedding of the space of induced metrics into the space of projectivized geodesic currents, which is compact. Taking the closure implies the first result. If  $[\mu]$  is the limiting projective geodesic current, then one can choose a fixed representative; call it  $\mu$ .

If  $\mu$  is a measured lamination, then dividing the current  $L_{\sigma_n e_n}$  by  $\mathcal{E}_n^{1/2}$  normalizes the current to have self-intersection number 1. Then, as the measured laminations have self-intersection 0, the second result follows.



Suppose then that  $\mu$  is not a measured lamination. Then its self-intersection number is positive and finite. But

$$\begin{aligned} i(\mu, \mu) &= \lim_{n \rightarrow \infty} i(c_n L_{\sigma_n e_n}, c_n L_{\sigma_n e_n}) = \lim_{n \rightarrow \infty} c_n^2 i(L_{\sigma_n e_n}, L_{\sigma_n e_n}) \\ &= \lim_{n \rightarrow \infty} c_n^2 \frac{\pi}{2} \text{Area}(S, \sigma_n e_n) = \lim_{n \rightarrow \infty} c_n^2 \frac{\pi}{2} \int_S \sigma_n e_n dz_n \wedge d\bar{z}_n \\ &= \lim_{n \rightarrow \infty} c_n^2 \frac{\pi}{2} \mathcal{E}_n, \end{aligned}$$

so that  $0 < \lim_{n \rightarrow \infty} c_n^2 \mathcal{E}_n < \infty$ ; that is,  $c_n \asymp \mathcal{E}_n^{-1/2}$ , as desired. □

With this normalization, the self-intersection of the current will be  $\frac{\pi}{2}$ ; that is to say we have scaled the induced metric to have total area 1.

The following proposition shows the relation of the induced metric to the corresponding Hopf differential metric.

**Proposition 5.7** *Away from the zeros of  $\Phi$ , one has the identity*

$$\sigma e = |\Phi| \left( \frac{1}{|v|} + |v| \right).$$

Consequently,

$$\sigma_n e_n \geq 2|\Phi_n|.$$

**Proof** This result follows immediately by manipulation of the formulae involving  $\mathcal{H}$  and  $\mathcal{L}$ . One has

$$\sigma^2 e^2 = \sigma^2 (\mathcal{H}^2 + 2\mathcal{H}\mathcal{L} + \mathcal{L}^2) = \sigma^2 \mathcal{H}\mathcal{L} \left( \frac{\mathcal{H}}{\mathcal{L}} + 2 + \frac{\mathcal{L}}{\mathcal{H}} \right) = |\Phi|^2 \left( \frac{1}{|v|^2} + 2 + |v|^2 \right).$$

Taking a square root on both sides yields the result. □

For a given sequence  $\sigma_n e_n$  we consider the associated smooth (away from the zeros of the quadratic differential) function  $1/|v_n| + |v_n|$ . This function is well-defined for each  $n$  by Lemma 4.5.

The following proposition due to Wolf allows us to pass freely between the  $L^1$ -norm of a Hopf differential and the total energy of the corresponding harmonic map. The original proof was for a fixed Riemann surface as the domain, but the argument holds when the domain is allowed to change. For the ease of the reader, we have included the adapted proof.

**Proposition 5.8** [44, Lemma 3.2] *For any Riemann surface  $(S, J)$  and hyperbolic surface  $(S, \sigma)$ , if  $\text{id}: (S, J) \rightarrow (S, \sigma)$  is a harmonic map with Hopf differential  $\Phi$  and total energy  $\mathcal{E}$ , then*

$$\mathcal{E} + 2\pi\chi(S) \leq 2\|\Phi\| \leq \mathcal{E} - 2\pi\chi(S).$$

**Proof** As  $\mathcal{H} - \mathcal{L} = \mathcal{J}$  and  $\int \mathcal{J}\sigma \, dz \, d\bar{z} = -2\pi\chi$ , we have

$$\int \mathcal{H}\sigma \, dz \, d\bar{z} + 2\pi\chi = \int \mathcal{L}\sigma \, dz \, d\bar{z} = \int \Phi v \, dz \, d\bar{z},$$

as the integrands agree. But, recalling that  $|v| < 1$ , we have

$$\int \Phi v \, dz \, d\bar{z} \leq \int |\Phi| \, dz \, d\bar{z} = \int \mathcal{H}|v|\sigma \, dz \, d\bar{z} \leq \int \mathcal{H}\sigma \, dz \, d\bar{z} = \int \mathcal{L}\sigma \, dz \, d\bar{z} - 2\pi\chi.$$

Summing up the first two and last two integrals respectively yields

$$\int e\sigma \, dz \, d\bar{z} + 2\pi\chi \leq 2 \int |\Phi| \, dz \, d\bar{z} \leq \int e\sigma \, dz \, d\bar{z} - 2\pi\chi,$$

proving the proposition.  $\square$

**Corollary 5.9** *If the sequence  $\Phi_{0,n}$  of unit-norm quadratic differential metrics converges projectively to a measured lamination, then so does the associated sequence  $L_{\sigma_n e_n} / \mathcal{E}_n^{1/2}$  of geodesic currents.*

**Proof** Suppose that  $L_{|\Phi_{0,n}|} \rightarrow [\lambda]$  in the space of projectivized currents. Since  $i(L_{|\Phi_{0,n}|}, L_{|\Phi_{0,n}|}) = \frac{\pi}{2}$ , while  $i(\lambda, \lambda) = 0$ , there exists a sequence  $t_n \rightarrow 0$  such that the length spectrum of  $t_n|\Phi_{0,n}|$  converges to that of some  $\lambda \in [\lambda]$ . This is to say, there is a curve class  $[\gamma]$  for which the length of its geodesic representative against the metric  $|\Phi_{0,n}|$  is unbounded, so by Propositions 5.7 and 5.8, the sequence of lengths of the  $[\gamma]$ -geodesic against the metrics  $\sigma_n e_n / \mathcal{E}_n$  is unbounded. Hence there is a sequence  $s_n \rightarrow 0$  such that  $s_n L_{\sigma_n e_n} / \mathcal{E}_n^{1/2}$  converges to a current  $\mu$ . But as the self-intersection of  $L_{\sigma_n e_n} / \mathcal{E}_n$  is exactly  $\frac{\pi}{2}$ , the intersection of  $\mu$  with itself is zero, from which the result follows.  $\square$

The previous corollary allows us to exclude the case where the sequence of flat metrics tends towards a projectivized measured lamination, for in that case, we have that the sequence of induced metrics also tends towards a projectivized measured lamination. Hence, we need only consider the case where the sequence of flat metrics converges to a nontrivial mixed structure, say  $\eta$ . The data of  $\eta$  gives us a subsurface  $S'$  for which the

restriction of  $\eta$  is a flat metric arising from a quadratic differential. Here we consider  $S'$  up to isotopy.

The remainder of the section is devoted towards showing that if the sequence of unit-norm quadratic differential metrics converges to a mixed structure that is not entirely laminar, then so does the sequence of unit-area induced metrics. This will then complete the proof of Theorem 5.5.

We begin by recording the following useful bound due to Minsky, for the function  $\mathcal{G} = \log(1/|\nu|)$ .

**Proposition 5.10** [29, Lemma 3.2] *Let  $p \in S$  be a point with a neighborhood  $U$  such that  $U$  contains no zeros of  $\Phi$  and in the  $|\Phi|$ -metric is a round disk of radius  $r$  centered at  $p$ . Then there is a bound*

$$\mathcal{G}(p) \leq \sinh^{-1} \left( \frac{|\chi(S)|}{r^2} \right).$$

**Proof** The PDE  $\Delta \mathcal{G} = 2\mathcal{J} > 0$  shows that  $\mathcal{G}$  is subharmonic in  $U$ . It suffices therefore to bound the average of  $\mathcal{G}$  on  $U$  in the  $|\Phi|$ -metric. Some algebra yields

$$\sinh \mathcal{G} = \frac{1}{2} \frac{\sigma}{|\Phi|} \mathcal{J}.$$

Using the concavity of  $\sinh^{-1}$  on the positive real axis, we obtain

$$\begin{aligned} \mathcal{G}(p) &\leq |\Phi|-\text{Avg}_U(\mathcal{G}) && \text{(by subharmonicity of } \mathcal{G}) \\ &= |\Phi|-\text{Avg}_U \left( \sinh^{-1} \frac{1}{2} \frac{\sigma}{|\Phi|} \right) \\ &\leq \sinh^{-1} \left( |\Phi|-\text{Avg}_U \left( \frac{1}{2} \frac{\sigma}{|\Phi|} \right) \right) && \text{(by concavity of } \sinh^{-1}) \\ &= \sinh^{-1} \left( \frac{1}{2\pi r^2} \int_U \frac{\sigma}{|\Phi|} \mathcal{J} \, dA(|\Phi|) \right) \\ &\leq \sinh^{-1} \left( \frac{|\chi(S)|}{r^2} \right) && \text{(by Gauss–Bonnet).} \quad \square \end{aligned}$$

As we are in the setting where the sequence  $L_{\Phi_{0,n}}$  of currents coming from unit-area holomorphic quadratic differential metrics converges to a nontrivial mixed structure  $\eta = (S', \Phi_\infty, \lambda)$ , we have that the restriction of the metric  $|\Phi_{0,n}|$  to  $S'$  converges to the metric  $|\Phi_\infty|$ . On this systole positive collection  $S'$  of subsurfaces, we have the following proposition.

**Proposition 5.11** Given  $\epsilon, \epsilon' > 0$ , there exists  $N = N(\epsilon, \epsilon')$  such that for  $n > N$ ,

$$m_{|\Phi_{0,n}|} \left( \left\{ p \in S : \left( \frac{1}{|v_n|} + |v_n| \right)(p) \geq 2 + \epsilon' \right\} \right) < \epsilon.$$

Consequently the limiting function  $1/|v| + |v|$  is equal to 2 almost everywhere with respect to the  $|\Phi_\infty|$ -metric.

**Proof** By Proposition 5.7, one has the equality

$$\frac{\sigma_n e_n}{\mathcal{E}_n} = \frac{|\Phi_n|}{\mathcal{E}_n} \left( \frac{1}{|v_n|} + |v_n| \right) = \frac{\|\Phi_n\|}{\mathcal{E}_n} \frac{|\Phi_n|}{\|\Phi_n\|} \left( \frac{1}{|v_n|} + |v_n| \right).$$

Defining

$$\frac{1 - c_n}{2} := \frac{\|\Phi_n\|}{\mathcal{E}_n},$$

one has  $c_n \rightarrow 0$  by virtue of Proposition 5.8. Observe that  $c_n \geq 0$ , as the function  $1/|v_n| + |v_n| \geq 2$ , the area of  $|\Phi_{0,n}| = |\Phi_n|/\|\Phi_n\|$  is 1 and the area of the scaled metric  $\sigma_n e_n/\mathcal{E}_n$  is also 1. If  $m_n$  then denotes the  $|\Phi_{0,n}|$ -measure of the set of points for which the function  $1/|v_n| + |v_n|$  is at least  $2 + \epsilon'$ , then one has

$$\begin{aligned} & \int_{\{p:(1/|v_n|+|v_n|)(p)\geq 2+\epsilon'\}} \left( \frac{1}{|v_n|} + |v_n| \right) \left( \frac{1 - c_n}{2} \right) dA(|\Phi_{0,n}|) \\ & + \int_{\{p:(1/|v_n|+|v_n|)(p)< 2+\epsilon'\}} \left( \frac{1}{|v_n|} + |v_n| \right) \left( \frac{1 - c_n}{2} \right) dA(|\Phi_{0,n}|) \\ & = \int dA \left( \frac{\sigma_n e_n}{\mathcal{E}_n} \right) = 1. \end{aligned}$$

The integrand in the first integral is at least  $(2 + \epsilon')(1 - c_n)/2$ , whereas the second integrand is at least  $2(1 - c_n)/2$ . Multiplying these lower bounds with the measures of their respective sets yields

$$(2 + \epsilon') \left( \frac{1 - c_n}{2} \right) m_n + 2 \left( \frac{1 - c_n}{2} \right) (1 - m_n) \leq 1.$$

Some basic algebraic manipulation leads from

$$m_n \left( (2 + \epsilon') \left( \frac{1 - c_n}{2} \right) - 2 \left( \frac{1 - c_n}{2} \right) \right) \leq c_n \quad \text{to} \quad m_n \leq \frac{2c_n}{(1 - c_n)(\epsilon')},$$

and as  $\epsilon'$  is now fixed, one may find a sufficiently large  $N$  to guarantee  $m_n < \epsilon$ . As the metric  $|\Phi_\infty|$  has finite total area, convergence in measure of the sequence of functions  $1/|v_n| + |v_n|$  to the constant function 2 implies that up to a subsequence, one has convergence to the constant function 2 almost everywhere. □

Sets of measure zero can be rather problematic if we wish to say something about length of curves. The following proposition shows that we actually have convergence off the zeros and poles of  $|\Phi_\infty|$ .

**Proposition 5.12** *Suppose  $\mathcal{E}_n \rightarrow \infty$ . Then, up to a subsequence,*

$$\frac{1}{|v_n|} + |v_n| \rightarrow 2$$

*everywhere on  $S'$  except at the zeros and poles of  $|\Phi_\infty|$ .*

**Proof** Observe that the function  $1/|v_n| + |v_n|$  is not defined at the zeros of  $|\Phi_n|$ , but is well-defined everywhere else. Moreover, the auxiliary function  $\mathcal{G} = \log(1/|v|)$  satisfies the partial differential equation

$$\Delta \log \frac{1}{|v_n|} = 2\mathcal{J}_n > 0,$$

so that the function  $\mathcal{G}$  and hence  $1/|v_n| + |v_n|$  never attains an interior maximum on the complement of the zeros. It follows that  $1/|v_n| + |v_n|$  is only unbounded in a neighborhood of a zero of a corresponding quadratic differential  $\Phi_n$ . The sequence of flat metrics  $|\Phi_{0,n}|$  on  $S'$  converges geometrically to  $|\Phi_\infty|$ , and so the zeros of  $|\Phi_n|$  on  $S'$  will converge to the zeros of  $|\Phi_\infty|$ . For any  $\epsilon > 0$ , consider balls of radius  $3\epsilon$  about each zero of  $|\Phi_\infty|$ , choosing  $\epsilon$  sufficiently small that balls about distinct zeros do not intersect. Call this collection  $B$ . Then for large  $n$ , balls of radius  $\epsilon$  in the  $|\Phi_{0,n}|$ -metric about the zeros of  $|\Phi_n|$  will be contained in  $B$ . For each boundary component of  $S'$ , which in the geometric limit is collapsed to a puncture, choose a geodesic curve with respect to the  $|\Phi_\infty|$ -metric, homotopic to the puncture and enclosing the puncture, of length  $l_\epsilon > 3\epsilon$ , so that the  $|\Phi_\infty|$ -distance of each point of the curve to the puncture is at least  $3\epsilon$ , possibly choosing a smaller  $\epsilon$  until such a configuration is possible. This gives an annulus for each boundary component of  $S'$ . Call the collection of these annuli  $A$ .

For any point in the complement of both  $A$  and  $B$ , for large  $n$ , the injectivity radius with respect to the  $|\Phi_{0,n}|$ -metric is at least  $\epsilon$  and the distance to any of the zeros is at least  $\epsilon$ . Moreover, each point  $p$  in the region satisfies the property that any  $q \in B_{\epsilon/2}(p)$  has injectivity radius at least  $\frac{\epsilon}{2}$  and distance at least  $\frac{\epsilon}{2}$  to any zero or the boundary of the cylindrical region. Hence, by Proposition 5.10, the value of  $\log(1/|v_n|)$  is at most  $M_{\epsilon/2}$ , where the constant no longer depends on  $n$ , once  $n$  is chosen sufficiently large.

As the function  $\log(1/|v_n|)$  is subharmonic, by the mean-value property, one has at any point  $p$  in this set that

$$\log \frac{1}{|v_n|}(p) \leq \int_{B_{\epsilon/2}(p)} \log \frac{1}{|v_n|} dA_{|\Phi_{0,n}|} \leq (|\Phi_{0,n}| - \text{Area}(B_{\epsilon/2}(p)))\epsilon' + M_{\epsilon/2}\epsilon''$$

for  $n$  large enough, so that  $\log(1/|v_n|) < \epsilon'$  outside a set of measure at most  $\epsilon''$  by Proposition 5.11. As the choice of  $\epsilon$  was arbitrary, the conclusion follows.  $\square$

This collection of propositions proves the following result:

**Theorem 5.13** *Suppose  $L_{|\Phi_{0,n}|}$  converges to a nontrivial mixed structure  $\mu$ . Then the corresponding metrics  $\sigma_n e_n / \mathcal{E}_n$  as  $\mathcal{E}_n \rightarrow \infty$ , restricted to  $S'$ , converge in length spectrum to  $|\Phi_\infty|$ .*

**Proof** Defining  $A$  and  $B$  as in the previous proof, on the region  $S' \setminus (A \cup B)$  Proposition 5.12 guarantees that we have uniform bounds on the sequence of functions  $1/|v_n| + |v_n|$  whose limit was the constant function 2. Hence, by Arzelá–Ascoli, up to a subsequence, we have uniform convergence on this region. Hence, by the same argument as that of Proposition 5.3, the length spectrum of the scaled induced metric on this domain converges to the limiting length spectrum of the sequence  $|\Phi_{0,n}|$ , which is  $|\Phi_\infty|$ .  $\square$

**Proof of Theorem 5.5** Recall that for any flat metric arising from a holomorphic quadratic differential, one can find a sequence of induced metrics so that the chosen flat metric is the limit in the space of geodesic currents (Proposition 5.3). Hence by Theorem 2.5, any mixed structure  $\eta$  can be obtained by a sequence  $L_{\sigma_n e_n}$  of currents coming from the induced metrics. On the other hand, to any sequence of induced metrics leaving all compact sets, then either it converges projectively to a measured lamination or it does not. If it does not converge to a measured lamination, then the energy is unbounded and the corresponding sequence of normalized Hopf differential metrics must converge to a mixed structure  $\mu$  which is not purely laminar. The previous theorem thus ensures there is a nonempty collection of incompressible subsurfaces,  $S'$ , on which the limiting current  $\eta$  is a flat metric. But on the complement of  $S'$ , the current  $\eta$  restricts to a measured lamination (as on this complement the areas of the metric tend to zero), so the proof of Theorem 5.5 is complete.  $\square$

## 5.4 Dimension of the boundary

We end this section with a remark about the compactification of the induced metrics. Recall the dimension of the space of induced metrics (being homeomorphic to  $\mathcal{Q}_g/\mathbb{S}^1$ ) was  $12g - 13$ . The dimension of the singular flat metrics can be readily seen to be  $12g - 14$ . The actual mixed structures are stratified by the subsurfaces for which the mixed structure is a flat metric. A subsurface of lower complexity yields fewer free parameters in the choice of a flat structure, and the extra choices one gains for a measured lamination on the complementary subsurface is strictly less in our loss of choice for the flat structure. Hence the boundary of the compactification of the induced metrics via projectivized geodesic currents is of codimension one.

## 6 Analysis of the limits

In this section, we wish to relate the mixed structures with cores of  $\mathbb{R}$ -trees arising from measured laminations. To this end, we elucidate the relation between the mixed structure and the pair of projective measured laminations obtained from the pair of degenerating hyperbolic surfaces.

### 6.1 $\mathbb{R}$ -trees

Here we recall some basic facts about  $\mathbb{R}$ -trees. An  $\mathbb{R}$ -tree  $T$  is a metric space for which any two points are connected by a unique topological arc, and such that the arc is a geodesic. Equivalently, if  $(X, d)$  is a metric space, for any pair of points  $x, y \in X$ , define the segment  $[x, y] = \{z \in X : d(x, y) = d(x, z) + d(z, y)\}$ . Then an  $\mathbb{R}$ -tree is a real nonempty metric space  $(T, d)$  satisfying:

- (i) For all  $x, y \in T$ , the segment  $[x, y]$  is isometric to a segment in  $\mathbb{R}$ .
- (ii) The intersection of two segments with an endpoint in common is a segment.
- (iii) The union of two segments of  $T$  whose intersection is a single point which is an endpoint of each is itself a segment.

A group  $\Gamma$  acts on  $T$  by *isometry* if there is a group homomorphism  $\theta: \Gamma \rightarrow \text{Isom}(T)$ . The action is from the left. An action is said to be *small* if the stabilizer of each arc does not contain a free group of rank two. An action is said to be *minimal* if no proper subtree is invariant under  $\Gamma$ .

A particularly important class of  $\mathbb{R}$ -trees comes from the leaf space of a lift of a measured foliation on a closed surface to its universal cover. Any measured foliation  $\mathcal{F}$  on a closed surface of genus  $g \geq 2$  may be lifted to a  $\pi_1 S$ -equivariant measured foliation on its universal cover. The leaf space can be made into a metric space, by letting the distance be induced from the transverse measure. This is an  $\mathbb{R}$ -tree with a  $\Gamma = \pi_1 S$  action by isometries. Naturally, not all  $\mathbb{R}$ -trees with a  $\pi_1 S$  action arise from this construction. A theorem of Skora [41] shows that an  $\mathbb{R}$ -tree with a  $\pi_1 S$  action comes from a measured foliation if and only if the action is small and minimal. Alternatively, one may start with a measured lamination  $(\lambda, \mu)$  on  $S$  and lift it to a measured lamination  $(\tilde{\lambda}, \mu)$  on the universal cover. Then an  $\mathbb{R}$ -tree may be formed by taking the connected components of  $\tilde{S} \setminus \tilde{\lambda}$  with edges between two vertices if the two components were adjacent (separated by a geodesic), and then metrically completing the distance induced by the transverse measure. The  $\mathbb{R}$ -tree comes equipped with a  $\pi_1 S$  action, and is  $\pi_1 S$ -equivariantly isometric to the  $\mathbb{R}$ -tree constructed from the corresponding measured foliation. In what follows, we will deal exclusively with  $\mathbb{R}$ -trees with a  $\pi_1 S$  action coming from the leaf space of the lift of a measured foliation. There is a rich theory of convergence of hyperbolic space to  $\mathbb{R}$ -trees in the literature from a number of different perspectives; see [3; 30; 31; 41; 46].

## 6.2 Convergence of metric spaces

In this section, we construct noncompact metric spaces admitting a  $\pi_1 S$  action by isometries.

**Definition 6.1** Let  $X$  and  $X'$  be two metric spaces and let  $\epsilon > 0$ . An  $\epsilon$ -approximation between  $X$  and  $X'$  is a relation  $R$  in  $X \times X'$  that is onto, and such that for every  $x, y \in X$  and every  $x', y' \in X'$ , the conditions  $xRx'$  and  $yRy'$  imply  $|d_X(x, y) - d_{X'}(x', y')| < \epsilon$ .

**Definition 6.2** Let  $X_n$  be a sequence of metric spaces, each admitting an isometric action by a group  $\Gamma$ , and let  $X_\infty$  be a supposed limiting metric space, also admitting an isometric action by the same group  $\Gamma$ . We say  $X_n$  converges to  $X_\infty$  in the sense of Gromov–Hausdorff if for every  $\epsilon > 0$  and every finite set  $A \subset \Gamma$ , and for every compact subset  $K \subset X_\infty$ , then, for  $n$  sufficiently large, there is a compact set  $K_n \subset X_n$  and an  $\epsilon$ -approximation  $R_n$  which is  $A$ -equivariant between  $K_n$  and  $K$  in the following sense: for every  $x \in K$ , every  $x_n, y_n \in K_n$ , and every  $\alpha \in A$ , the conditions  $\alpha x \in K$  and  $x_n R_n x$  and  $y_n R_n \alpha x$  imply  $d(\alpha x_n, y_n) < \epsilon$ .



We construct a sequence of noncompact metric spaces  $X_n$  with an isometric action by  $\Gamma = \pi_1 S$ , as follows. Take the induced metric  $(S, \sigma_n e_n)$  and lift the metric to the universal cover  $(\tilde{S}, \widetilde{\sigma_n e_n})$ . We will deal with the case where the induced metric converges in length spectrum to a mixed structure that is not entirely laminar — this is to ensure so that we can scale our metric spaces by total energy; for the case of a mixed structure that is entirely laminar, the same discussion holds after amending the sequence of constants. The sequence of noncompact metric spaces thus will be  $X_n = (\tilde{S}, \widetilde{\sigma_n e_n} / \mathcal{E}_n)$ . The following proposition is clear.

**Proposition 6.1** *The manifold  $X_n = (\tilde{S}, \widetilde{\sigma_n e_n} / \mathcal{E}_n)$  is a noncompact metric space admitting an isometric action by the group  $\Gamma = \pi_1 S$ .*

**Proof** As  $X_n$  itself is a noncompact Riemannian manifold with  $\Gamma = \pi_1 S$  acting on it by isometries, the result follows immediately.  $\square$

Up to a subsequence, the metrics  $(S, \sigma_n e_n / \mathcal{E}_n)$  will converge in length spectrum to a nontrivial mixed structure  $\eta = (S', q, \lambda)$ . We construct a noncompact metric space  $X_\infty = X_\eta$  from the mixed structure  $\eta$ . Regard  $\eta$  as a geodesic current on  $(\tilde{S}, g)$ . To any two distinct points  $x, y \in \tilde{S}$ , one can form the geodesic arc  $\alpha$  connecting the two points. Let  $c$  be the set of bi-infinite geodesics which intersect  $\alpha$  transversely. Then the intersection number  $i(\eta, \alpha)$  is given by the  $\eta$ -measure of  $c$ . This yields a pseudometric space coming from the geodesic current  $\eta$ . Notice that it is possible for the intersection number to be zero, for instance if the geodesic arc is disjoint from the support of the current, or if it forms no nontransverse intersection with the support of  $\eta$ . Taking the quotient by identifying points which are distance 0 from each other, and then taking the metric completion, yields a noncompact metric space  $X_\infty$ . As  $\Gamma = \pi_1 S$  acted on  $\eta$  equivariantly,  $\Gamma$  acts by isometries on  $X_\infty$ . For a more detailed discussion about the construction of a metric space from the data of a geodesic current, see [5].

**Remark** In the setting where  $\eta$  is a measured foliation, the metric space  $X_\eta$  is a familiar one. It is an  $\mathbb{R}$ -tree dual to the foliation. The space is constructed by collapsing the leaves of the foliation with the distance on the tree inherited by intersection number and then completing; see [32]. The case where  $\eta$  is a nontrivial mixed structure follows the same spirit of this construction. The laminar part is treelike, formed on the universal cover by collapsing leaves of the supported lamination and then completing. On the flat part, the metric space is formed by the product of the trees dual to the vertical and horizontal lamination of a quadratic differential whose metric is the given flat metric.

The preceding discussion is summarized by the following proposition.

**Proposition 6.2** *To any mixed structure  $\eta$ , the construction above gives a noncompact metric space  $X_\eta$  admitting an isometric action by  $\Gamma = \pi_1 S$ .*

Using the Gromov–Hausdorff topology, one has the following.

**Theorem 6.3** *A subsequence of the metric spaces  $(\tilde{S}, \widetilde{\sigma_n e_n} / \varepsilon_n)$  converges in the sense of Gromov–Hausdorff to a noncompact metric space  $X_\eta$  coming from a mixed structure  $\eta$  acted upon by  $\Gamma = \pi_1 S$ .*

Before presenting the proof, we record one useful fact regarding convergence of maps. This follows from work of Korevaar and Schoen.

**Theorem 6.4** (Korevaar and Schoen [21]; see also [8]) *Let  $\tilde{M}$  be the universal cover of a compact Riemannian manifold. Let  $u_k: \tilde{M} \rightarrow X_k$  be a sequence of maps such that*

- (a) *each  $X_k$  is an NPC space, and*
- (b) *the  $u_k$  have uniform modulus of continuity: for each  $x$ , there is a monotone function  $\omega(x, \cdot)$  such that*

$$\lim_{R \rightarrow 0} \omega(x, R) = 0 \quad \text{and} \quad \max_{B(x, R)} d(u_k(x), u_k(y)) \leq \omega(x, R).$$

*Then the pullback metrics  $d_{u_k}$  converge (possibly after passing to a subsequence) pointwise, locally uniformly to a pseudometric  $d_\infty$ .*

**Proof of Theorem 6.3** Recall from Theorem 5.13 that on  $S'$  we have uniform convergence of the induced metric to the flat metric. For the complementary subsurface, recall that metric spaces were obtained as the induced metric on the minimal surface, so that the metric came from a pullback of a harmonic map. By Proposition 5.6, the scaled metric is the pullback metric of a harmonic map with energy at most 1. Hence, by Theorem 6.4 (see [21, Proposition 3.7] or [8, Theorem 2.2]), the metrics converge uniformly. As the lifts of the induced metrics admitted an  $\pi_1 S$  action by isometries, so does the limit.  $\square$

### 6.3 Convergence of harmonic maps

Not only do the metric spaces converge in a suitable topology, the harmonic maps do as well. As we have shown in the preceding section that the domains converge in the sense

of Gromov–Hausdorff to a metric space arising from a mixed structure, and as shown in work of Wolf [46], one has that the lifts of a sequence of degenerating hyperbolic metrics, when properly scaled, subconverge in the sense of Gromov–Hausdorff to  $\mathbb{R}$ –trees dual to a particular measured lamination in the projective class of the associated point on the Thurston boundary. Hence we have both domain and target converging in the same topology to noncompact metric spaces with isometric actions by  $\Gamma = \pi_1 S$ . It is natural to expect some sort of convergence in the harmonic maps. In Wolf [46], the domain is a fixed Riemann surface, and the target is changing. Here, we have both domain and target changing (and converging). We begin by reviewing the necessary definitions.

**Definition 6.3** Let  $X_n$  and  $X_\infty$  be metric spaces admitting an action of a group  $\Gamma$  and let  $(Y_n, d_n)$  and  $(Y_\infty, d_\infty)$  be metric spaces admitting an isometric action of  $\Gamma$ . Suppose  $f_n: X_n \rightarrow Y_n$  and  $f_\infty: X_\infty \rightarrow Y_\infty$  are equivariant maps. Then we say that  $f_n$  converges (uniformly) to  $f$  if

- (i) both  $X_n$  and  $Y_n$  converge (uniformly) to  $X$  and  $Y$  respectively in the sense of Gromov, and
- (ii) for every  $\epsilon > 0$ , there is an  $N(\epsilon)$  such that for  $n > N(\epsilon)$ , the  $\epsilon$ –approximations  $R_n, R'_n$  satisfy the condition that for every  $x_n R_n x$ , one has  $f_n(x_n) R'_n f(x)$ .

We will require a notion of harmonic map for maps between singular spaces. The following can be found in more detail in [10]. While the general theory of harmonic maps between Riemannian polyhedra is covered there, in what follows, we only deal with singular flat metrics and metric graphs.

**Definition 6.4** Let  $X$  be an admissible Riemannian polyhedron and  $Y$  a metric space. Let  $\phi \in L^2_{\text{loc}}(X, Y)$ . The approximate energy density is defined for  $\epsilon > 0$  by

$$e_\epsilon(\phi)(x) = \int_{B_X(x, \epsilon)} \frac{d_Y^2(\phi(x), \phi(x'))}{\epsilon^{m+2}} d\mu_g(x').$$

**Definition 6.5** The energy  $E(\phi)$  of a map  $\phi$  of class  $L^2_{\text{loc}}(X, Y)$  is

$$E(\phi) = \sup_{f \in C_c(X, [0, 1])} \left( \limsup_{\epsilon \rightarrow 0} \int_X f e_\epsilon(\phi) d\mu_g \right).$$

**Definition 6.6** A harmonic map  $\phi : X \rightarrow Y$  is a continuous map of class  $W_{\text{loc}}^{1,2}(X, Y)$  which is bi-locally  $E$ -minimizing in the sense that  $X$  can be covered by relatively compact subdomains  $U$  for each of which there is an open set  $V \supset \phi(U)$  in  $Y$  such that

$$E(\phi|_U) \leq E(\psi|_U)$$

for every continuous map  $\psi \in W_{\text{loc}}^{1,2}(X, Y)$  with  $\psi(U) \subset V$  and  $\psi = \phi$  in  $X \setminus U$ .

We obtain a classification of the flat parts of the mixed structure arising from the data of the limits of the sequences  $X_{1,n}$  and  $X_{2,n}$ . Let  $S'$  be a connected subsurface for which the limiting mixed structure  $\eta$  is a flat metric. For each  $n$ , denote by  $S'_n$  the subsurface isotopic to  $S'$  such that the boundary components are geodesics with respect to the induced metric  $\sigma_n e_n / \mathcal{E}_n$ . Let  $X'_{1,n}$  denote the restriction of the hyperbolic metric  $X_{1,n}$  to the subsurface of  $S$ , in the same isotopy class of  $S'$ , but which has geodesic boundary with respect to the hyperbolic metric. Then let  $u'_{i,n}$  denote the restriction to  $S'_n$  of the harmonic map  $u_{i,n} : (S, \sigma_n e_n) \rightarrow X_{i,n}$ .

**Theorem 6.5** Consider a connected component of  $S'$ . The sequence of harmonic maps  $u'_{1,n} : (S'_n, \sigma_n e_n / \mathcal{E}_n) \rightarrow X_{1,n} / 2\mathcal{E}_n$  converges to a  $\pi_1(S')$ -equivariant harmonic map  $u' : (S', |\Phi_\infty|) \rightarrow T_1$ , where  $T_1$  is the  $\mathbb{R}$ -tree dual to  $\lambda_1 = \lim_{n \rightarrow \infty} X_{1,n} / 2\mathcal{E}_n$ . The Hopf differential is given by  $\Phi_\infty$ . Likewise, the same holds for  $\lambda_2$  and  $-\Phi_\infty$ . Hence, the laminations are the vertical and horizontal foliations of  $\Phi_\infty$ .

**Proof** We begin by showing that  $\lambda_1$  is a well-defined measured lamination in the projective class of  $[\lambda_1]$ , which is the limit on the Thurston boundary of the sequence  $X_{1,n}$ . This will follow from standard estimates on stretching and geodesic curvature of an arc of the horizontal foliation which avoids the zeros. This will be an adaptation of the argument employed in [45], for the case where the domain conformal structure is fixed and the Hopf differentials lie along a ray.

We first show boundedness of the Jacobian. For any neighborhood  $U$  of the surface which avoids a zero of  $\Phi_{0,n}$ , one has the usual PDE

$$(6-1) \quad \Delta_{\sigma_n} \log \frac{1}{|v_n|^2} = 4\mathcal{J}_n > 0,$$

and, consequently,

$$(6-2) \quad \Delta_{\sigma_n} \|\Phi_n\| \log \frac{1}{|v_n|^2} = 4\|\Phi_n\| \mathcal{J}_n > 0.$$

Using the conformal invariance of harmonic maps, we replace the metric  $\sigma_n$  on the neighborhood  $U$  with a metric  $\sigma'_n$  in the same conformal class as  $\sigma_n$ , but one which is flat on  $U$ . Subharmonicity of the function  $\|\Phi_n\| \log(1/|v_n|^2)$  yields

$$(6-3) \quad \|\Phi_n\| \log \frac{1}{|v_n|^2}(p) \leq \frac{1}{\pi R^2} \int_{B_R(p)} \|\Phi_n\| \log \frac{1}{|v_n|^2} dA(\sigma'_n)$$

on a ball of  $\sigma'_n$  radius  $R$  contained in  $U$ . Some algebra yields

$$(6-4) \quad \mathcal{J}_n(p) \frac{\|\Phi_n\| \log |v_n|^{-2}(p)}{\mathcal{J}_n(p)} \leq \frac{1}{\pi R^2} \int_{B_R(p)} \frac{\mathcal{J}_n}{\mathcal{J}_n} \|\Phi_n\| \log \frac{1}{|v_n|^2} dA(\sigma'_n),$$

and hence

$$(6-5) \quad \mathcal{J}_n(p) \leq \frac{\mathcal{J}_n(p)}{\|\Phi_n\| \log |v_n|^{-2}(p)} \left( \sup_{q \in B_R(p)} \frac{\|\Phi_n\| \log |v_n|^{-2}(q)}{\mathcal{J}_n(q)} \right) \frac{1}{\pi R^2} \int_{B_R(p)} \mathcal{J}_n dA(\sigma'_n).$$

But one has that

$$(6-6) \quad \frac{\mathcal{J}_n}{\|\Phi_n\| \log |v_n|^{-2}} = \frac{|\Phi_{0,n}| (1 - |v_n|^2)}{\sigma_n |v_n| \log |v_n|^{-2}},$$

so that in applying Proposition 5.12 to the expression (6-6), one obtains that (6-5) may be rewritten as

$$(6-7) \quad \mathcal{J}_n(p) \leq c_n \int_{B_R(p)} \mathcal{J}_n dA(\sigma'_n),$$

where  $c_n$  will depend on the metric  $|\Phi_{0,n}|$ ,  $|v_n|$ ,  $R$  and  $\sigma_n$ . But, on the neighborhood  $U$ , we know for sufficiently large  $n$  that  $|\Phi_n| \rightarrow |\Phi_\infty|$ , and  $|v_n| \rightarrow 1$  and  $\sigma_n \rightarrow \sigma_\infty$ , where  $\sigma_\infty$  is the uniformizing metric of  $\Phi_\infty$ . Hence  $c_n$  remains bounded on  $U$ . But, finally,

$$(6-8) \quad \int_{B_R(p)} \mathcal{J}_n dA(\sigma'_n) = \int_{B_R(p)} \frac{\sigma'_n}{\sigma_n} \mathcal{J}_n dA(\sigma_n) \leq \sup_U \frac{\sigma'_n}{\sigma_n} \int_M \mathcal{J}_n dA(\sigma_n) \leq -2\pi \chi(S) c'_n,$$

where here  $c'_n$  will only depend upon the injectivity radius of the metric  $\sigma_n$  on the neighborhood  $U$ , which for large  $n$  will be close to the injectivity radius of  $\sigma_\infty$ .

From (6-7), (6-8) and the PDE in (6-1), by elliptic regularity (see [14, Problem 4.8a]) one obtains that  $|v_n| \rightarrow 1$  in  $C^{1,\alpha}(U)$ , where  $U$  does not contain a zero or pole of  $\Phi_\infty$ .

In the natural coordinates of the quadratic differential, the hyperbolic metric  $g_{1,n}$  is given by  $(\sigma_n e_n + 2\|\Phi_n\|) d\xi_n^2 + (\sigma_n e_n - 2\|\Phi_n\|) d\eta_n^2$ .

Recall that the geodesic curvature of an arc of the horizontal foliation of  $\Phi_{0,n}$  in the natural coordinates for  $\Phi_{0,n} = d\xi_n^2 = d\xi_n^2 + d\eta_n^2$  is given by the equation

$$(6-9) \quad \kappa(\gamma)_{\eta=\text{constant}} = -\frac{1}{2g_{11,n}\sqrt{g_{22,n}}} \frac{\partial g_{11,n}}{\partial \eta_n},$$

so that for  $\gamma$  an arc of the horizontal foliation of  $\Phi_{0,n}$  avoiding the zeros, one has

$$(6-10) \quad \begin{aligned} \kappa(\gamma)_{\eta=\text{constant}} &= -\frac{1}{2(\sigma_n e_n + 2\|\Phi_n\|)(\sigma_n e_n - 2\|\Phi_n\|)^{1/2}} \frac{\partial}{\partial \eta_n} (\sigma_n e_n + 2\|\Phi_n\|) \\ &= -\frac{1}{2\mathcal{J}_n(\sigma_n e_n + 2\|\Phi_n\|)^{1/2}} \frac{\partial}{\partial \eta_n} \sigma_n e_n. \end{aligned}$$

But simple algebra yields that  $\sigma_n e_n = \|\Phi_n\| |\Phi_{0,n}| (|v_n|^{-1} + |v_n|)$ , so that in the natural coordinates as  $|\Phi_{0,n}| \equiv 1$ , one actually has  $\sigma_n e_n = \|\Phi_n\| (|v_n|^{-1} + |v_n|)$ . Hence

$$(6-11) \quad \kappa(\gamma) = \frac{1}{2} \|\Phi_n\| (1 - |v_n|^2) \mathcal{J}_n^{-1} |v_n|^{-2} (\sigma_n e_n + 2\|\Phi_n\|)^{-1/2} \frac{\partial}{\partial \eta_n} |v_n|$$

$$(6-12) \quad = \frac{1}{2} \|\Phi_n\| \mathcal{H}_n^{-1} |v_n|^{-2} (\sigma_n e_n + 2\|\Phi_n\|)^{-1/2} \frac{\partial}{\partial \eta_n} |v_n|,$$

as  $\mathcal{J}_n = \mathcal{H}_n(1 - |v_n|^2)$ . As  $\|\Phi_n\| \mathcal{H}_n^{-1} = |v_n|/|\Phi_{0,n}|$ , rewriting (6-12) gives

$$(6-13) \quad \kappa(\gamma) = \frac{1}{2} \frac{1}{(|\Phi_{0,n}| \cdot |v_n|)(\sigma_n e_n + 2\|\Phi_n\|)^{1/2}} \cdot \frac{\partial}{\partial \eta_n} |v_n|,$$

and as  $|v_n| \rightarrow 1$  in  $C^{1,\alpha}(U)$ , one obtains  $\kappa_{g_{1,n}}(\gamma) = o(\|\Phi_n\|^{-1/2}) = o(\mathcal{E}_n^{-1/2})$ .

Then to any arc  $\gamma$  of the horizontal foliation of  $\Phi_n$ , one has that it is mapped close to its geodesic in the target hyperbolic surface. The following standard calculation on the stretching shows that by normalizing the target hyperbolic manifold by the total energy, the resulting length is given by the intersection number with the measured lamination  $\lambda_1$ . One has

$$\begin{aligned} l_{g_{1,n}}(\gamma) &= \int_{\gamma} \mathcal{H}_n^{1/2} + \mathcal{L}_n^{1/2} ds_{\sigma_n} = \int_{\gamma} \mathcal{H}_n^{1/2} (1 + |v_n|) ds_{\sigma_n} \\ &= \int_{\gamma} \frac{\|\Phi_n\|^{1/2} |\Phi_0|^{1/2}}{|v_n|^{1/2}} (1 + |v_n|) \frac{ds_{\sigma_n}}{\sigma_n^{1/2}} \\ &= \|\Phi_n\|^{1/2} \int_{\gamma} \left( 1 + \left( \frac{1}{|v_n|^{1/2}} - 1 \right) \right) (2 - (1 - |v_n|)) ds_{|\Phi_0|} \\ &= 2\|\Phi_n\|^{1/2} l_{|\Phi_{0,n}|}(\gamma) + O(\|\Phi_n\|^{1/2} (1 - |v_n|)), \end{aligned}$$

recalling that in order to obtain the metric  $\sigma e$ , one has to divide both hyperbolic surfaces by twice the energy, which is approximately four times the  $L^1$ -norm of the Hopf differential for sufficiently large energy, independent of the Riemann surface structure; see Proposition 5.8. Meanwhile, a similar calculation shows that an arc of the vertical foliation of  $\Phi_n$ , say  $\alpha$ , has length in the target hyperbolic surface given by

$$\begin{aligned} l_{g_{1,n}}(\alpha) &= \int_{\alpha} \mathcal{H}_n^{1/2} - \mathcal{L}_n^{1/2} ds_{\sigma_n} = \int_{\alpha} \mathcal{H}_n^{1/2}(1 - |v_n|) ds_{\sigma_n} \\ &= \int_{\alpha} \frac{\|\Phi_n\|^{1/2} |\Phi_{0,n}|^{1/2}}{\sigma_n^{1/2} |v_n|^{1/2}} (1 - |v_n|) ds_{\sigma_n} \\ &= \|\Phi_n\|^{1/2} \int_{\alpha} \frac{1 - |v_n|}{|v_n|^{1/2}} ds_{|\Phi_{0,n}|} \\ &= o(\mathcal{E}_n^{1/2}). \end{aligned}$$

Noting that a horizontal arc of  $\Phi_n$  is a vertical arc of  $-\Phi_n$ , one sees the  $\lambda_1$  and  $\lambda_2$  are the horizontal and vertical foliations of  $\Phi_{\infty}$  (the geometric limit of  $\Phi_n$ ; see [27]), respectively.

To get our desired harmonic map from the flat subsurface to the two trees, notice that the above estimates show that a horizontal arc of  $\Phi_{0,n}$  gets mapped close to a geodesic in the target space which is a hyperbolic surface scaled by the reciprocal of total energy. As the scaled induced metric limits to the flat metric  $|\Phi_{\infty}|$ , a horizontal arc of  $\Phi_{\infty}$  will thus be mapped by an isometry to the tree  $T_1$  and any vertical arc collapsed, so that the limiting map in the universal cover is given by a projection onto the leaf space of the vertical foliation of  $\Phi_{\infty}$ . The same argument holds for  $T_2$ . □

**Proposition 6.6** *For any closed curve  $\gamma$  on the surface  $S$ , one has the inequalities*

$$l_{g_{1,n}}(\gamma) \leq l_{\sigma_n e_n}(\gamma) \quad \text{and} \quad l_{g_{2,n}}(\gamma) \leq l_{\sigma_n e_n}(\gamma).$$

Consequently, if  $t_n L_{\sigma_n e_n} \rightarrow \eta$  as currents, then the length spectra of  $\lim_{n \rightarrow \infty} t_n L_{g_{i,n}}$  are well-defined. If the limiting currents are denoted by  $\lambda_j$ , then

$$i(\lambda_j, \cdot) \leq i(\eta, \cdot).$$

**Proof** As the minimal surface has induced metric of the form  $g_{1,n} + g_{2,n}$ , where the  $g_{i,n}$  is a hyperbolic metric, both inequalities follow immediately. The final comment follows from choosing a closed curve  $\gamma = \gamma_n$  to be a  $\sigma_n e_n$ -geodesic and using the inequality  $l_{t_n^2 g_{i,n}}([\gamma]) \leq l_{t_n^2 g_{i,n}}(\gamma)$ . □

Combining Proposition 6.6 and Theorem 6.5, we obtain a necessary and sufficient condition on the pair of measured laminations  $\lambda_1$  and  $\lambda_2$  to determine a corresponding flat part on the mixed structure. Recall that a pair of measured laminations  $\lambda_1, \lambda_2$  *fill* if for any measured lamination  $\lambda_3$ , one has  $i(\lambda_1, \lambda_3) + i(\lambda_2, \lambda_3) > 0$ .

**Corollary 6.7** *Let  $\lambda'_i = \lim_{n \rightarrow \infty} X'_{i,n}/2\mathcal{E}_n$  be a pair of nonzero measured laminations on a subsurface  $S'$ . Then the pair of laminations fill if and only if the restriction of the mixed structure  $\eta$  to  $S'$  is flat.*

**Proof** If  $\eta$  is flat on  $S'$ , the preceding theorem shows the pair of laminations are dual and hence fill. If the pair of laminations do fill, then for any third lamination  $\lambda'$  one has by Proposition 6.6 that  $i(\eta, \lambda') > 0$ , so that it cannot be a lamination, and hence must be flat by definition of a mixed structure.  $\square$

**Proposition 6.8** *On the subsurface  $S'' = S \setminus S'$ , the laminations  $\lambda_1$  and  $\lambda_2$  restrict to a pair of measured laminations which have no transverse intersection. If  $\lambda$  denotes the measured lamination part of the mixed structure, then  $i(\lambda, \lambda_1) = i(\lambda, \lambda_2) = 0$ .*

**Proof** By Proposition 6.6, since  $i(\lambda, \lambda) = 0$ , one has that  $i(\lambda_1, \lambda) = i(\lambda_2, \lambda) = 0$ . Using the inequality again yields  $i(\lambda_1, \lambda_2) \leq i(\lambda, \lambda_2) = 0$ , from which the result follows.  $\square$

In the setting where both singular spaces are finite metric graphs, the resulting harmonic maps are *affine maps*. Each edge of the domain graph is mapped via the constant map, or mapped linearly to the target graph. The following result of Lebeau characterizes all such harmonic maps.

**Theorem 6.9** (Lebeau [25]) *Given two finite metric graphs  $G$  and  $G'$ , every continuous map between  $G$  and  $G'$  is homotopic to an affine map which minimizes the energy within its homotopy class. Furthermore, the map is unique up to parallel transport.*

**Proposition 6.10** *Suppose  $L_{\sigma_n e_n/C_n}$  converges to  $\lambda$ , where  $\lambda$  is a Jenkins–Strebel lamination (measured lamination supported on finitely many closed curves). Then the sequence of metric spaces  $(S, \sigma_n e_n/C_n)$  converges geometrically to a finite metric graph.*

**Proof** This follows immediately from Theorem 6.4 (see also [21, Proposition 3.7]), as the induced metrics are the pullback metrics of a harmonic map from  $\mathbb{H}^2$  to  $\mathbb{H}^2 \times \mathbb{H}^2$ ,



which is NPC. The assumption on the modulus of continuity follows from the bound on the total energy of the maps  $u_n$  to the rescaled target, so that total energy is at most 1. Hence, the limiting metric space is the dual graph of  $\lambda$ , which is a finite metric graph.  $\square$

**Theorem 6.11** *Let  $C_n \rightarrow \infty$ , so that  $L_{\sigma_n e_n/C_n} \rightarrow \eta$ , where  $\eta$  is a mixed structure with laminar part supported on a finite collection of simple closed curves. Suppose  $L_{X_{i,n}/C_n} \rightarrow \lambda_i$ , where  $\lambda_i$  are measured laminations also supported on a finite collection of simple closed curves. Then the sequence of harmonic maps  $u_{i,n}: (S, \sigma_n e_n/C_n) \rightarrow X_{i,n}/C_n$  converges to a map  $u_i: X_\eta \rightarrow T_i$ , which is a union of harmonic maps.*

**Proof** Recall that  $X_\eta$  is the metric completion of the metric space obtained from the geodesic current  $\eta$  by creating a pseudometric space from the intersection number with  $\eta$ , and then identifying points with 0 distance.

As the case where  $\eta$  is flat has been previously handled in Theorem 6.5, we first construct a  $\pi_1 S$ -equivariant map between the laminar part of  $X_\eta$  and  $T_1$  (here we will consider only the case where  $\eta$  is a Jenkins–Strebel lamination). The same construction will produce a similar map to  $T_2$ . Let  $D$  be a connected fundamental domain of the laminar region of  $X_\eta$ . Then  $D$  is a finite metric graph. We embed the graph  $D$  into the laminar region  $S''$  of the minimal surface as follows: we map each vertex of  $D$  to its corresponding thick region on  $S''$ . The geometric convergence of the minimal surfaces to  $D$  from Proposition 6.10 allows us to determine which region of the minimal surface will converge to a given vertex. Once we have made our choice of where to send each vertex of  $D$ , if there is an edge  $e$  connecting two vertices of  $D$ , then we send the edge  $e$  to the geodesic arc connecting the two points on the minimal surface where we have mapped our two vertices. (The limiting map we will obtain later will not depend on this choice, as distances will converge uniformly.)

As we have convergence in length spectrum and as there are only finitely many edges, we can ensure that for large  $n > N(\epsilon)$ , the length of the image of each edge has changed by at most  $\epsilon$ . We require that the embedding is proportional to arclength. Then there is a collection of continuous maps  $\phi_n: D \rightarrow X_n$  with the property that given  $\epsilon > 0$ , there is an  $N = N(\epsilon)$  so that  $\phi_n$  is a  $(1 + \epsilon)$ -quasi-isometry.

Likewise, as  $\tilde{X}_{1,n}/C_n$  converges geometrically to an  $\mathbb{R}$ -tree, a fundamental domain of  $\tilde{X}_{1,n}/C_n$  will converge geometrically to a finite graph  $G_1$ ; see for instance [46]. Hence,

there is a collection of continuous maps  $\psi_n: X_{1,n}/C_n \rightarrow G_1$  with the same property as  $\phi_n$ .

Form the composition  $g_n = \psi_n \circ u_{1,n} \circ \phi_n: D \rightarrow G_1$ , where  $u_{1,n}: (S, \sigma_n e_n/C_n) \rightarrow X_{1,n}/C_n$  is a harmonic map with total energy at most 1. We claim this sequence of maps  $g_n$  is uniformly bounded and equicontinuous. Uniform boundedness is clear as the target graph  $G_1$  is a finite graph. To see it is equicontinuous, we note that, as  $\phi_n$  and  $\psi_n$  were  $(1+\epsilon)$ -quasi-isometries, and since there is a uniform Lipschitz constant of the maps  $u_{1,n}$ , as the total energy of the maps are bounded by 1 (see [20, Theorem 2.4.6]), equicontinuity follows. Hence, by the Arzelà–Ascoli theorem, we have a subsequence  $g_k$  converging uniformly to a map  $g: D \rightarrow G_1$ .

We have that  $g$  is harmonic as a map between singular spaces, for we have uniform convergence of distances (see [21]) between the approximate metric spaces coming from our scaled induced metrics and the limiting  $\mathbb{R}$ -tree. Hence all the quantities in the definitions of the approximate energy density, and the energy, converge. As there is a unique energy minimizer (up to parallel transport, by Theorem 6.9) between the limiting spaces (which are finite graphs), the map  $g$  must be this unique energy minimizer. (If  $g$  were not the energy minimizer, it would have larger energy than the unique energy minimizer, by say  $\delta$ . One could then construct a map between the approximate Riemannian manifolds, which would have energy lower than the harmonic maps  $u_{1,n}$ , contradicting the harmonicity of  $u_{1,n}$ .)

From Theorem 6.5, we obtained a limiting harmonic map  $u'$  on the flat part of  $X_\eta$  to the tree  $T_1$ , and now we have a limiting harmonic map  $g$  from the laminar part of  $X_\eta$  to the tree  $T_1$ . Taking the union yields the desired  $u: X_\eta \rightarrow T_1$ . The same argument holds for  $T_2$ .  $\square$

## 6.4 Cores of trees

Here we review some basics of cores of  $\mathbb{R}$ -trees. A more detailed overview of this material may be found in [18; 46].

For any  $\mathbb{R}$ -tree, a *direction* at a point  $x \in T$  is a connected component of  $T \setminus x$ . A *quadrant* in  $T_1 \times T_2$  is the product  $\delta_1 \times \delta_2$  of two directions  $\delta_1 \subset T_1$  and  $\delta_2 \subset T_2$ . We will say that the quadrant is based at  $(x_1, x_2) \in T_1 \times T_2$ , where  $x_i$  is the basepoint for the direction  $\delta_i$ .

Let  $T_1, T_2$  be a pair of trees with a common group action by  $\Gamma$ . Let  $x = (x_1, x_2) \in T_1 \times T_2$  be a basepoint.

**Definition 6.7** Consider a quadrant  $Q = \delta_1 \times \delta_2 \subset T_1 \times T_2$ . Then  $Q$  is said to be *heavy* if there exists a sequence  $\gamma_k \in \Gamma$  such that

- (i)  $\gamma_k \cdot x \in Q$ ,
- (ii)  $d_i(\gamma_k \cdot x_i, x_i) \rightarrow \infty$  as  $k \rightarrow \infty$  for  $i = 1, 2$ .

Otherwise we say  $Q$  is *light*.

We define the *core* of a product of trees to be the product  $T_1 \times T_2$  with all light quadrants removed.

**Definition 6.8** (Guirardel [18]) The *core*  $\mathcal{C}$  of  $T_1 \times T_2$  is the subset

$$\mathcal{C} = T_1 \times T_2 \setminus \left[ \bigcup_{Q \text{ light quadrant}} Q \right].$$

Take a pair  $\gamma_1, \gamma_2$  of simple closed geodesics on a hyperbolic surface and let  $T_1$  and  $T_2$  be the trees dual to the laminations. On the surface  $S$ , foliate by parallel curves a small open tubular neighborhood  $A_i = \gamma_i \times (-\epsilon, \epsilon)$  of each of the curves. Define the map  $p_i: \tilde{S} \rightarrow T_i$  which maps the connected components of  $\tilde{S} \setminus \tilde{A}_i$  to the corresponding vertex of  $T_i$  and each  $\tilde{A}_i$  to the corresponding edge of  $T_i$ . This construction extends to measured laminations, as the simple closed curves are dense in the space of measured laminations. The following proposition characterizes the core in terms of the map  $p = (p_1, p_2)$ .

**Proposition 6.12** [18] *Let  $T_1$  and  $T_2$  be dual to a pair of measured laminations  $\lambda_1$  and  $\lambda_2$ , respectively. Consider the map  $p = (p_1, p_2): \tilde{S} \rightarrow T_1 \times T_2$ , as defined above. Then  $\mathcal{C}(T_1 \times T_2) = p(\tilde{S})$ .*

**Proof** The result will follow from the claim that any quadrant  $Q = \delta_1 \times \delta_2$  in  $T_1 \times T_2$  is light if and only if  $p_1^{-1}(\delta_1) \cap p_2^{-1}(\delta_2) = \emptyset$ . It is clear that if  $p_1^{-1}(\delta_1) \cap p_2^{-1}(\delta_2) = \emptyset$ , then  $Q$  is light, as for each point  $x \in \tilde{S}$ , the orbit of  $(p_1(x), p_2(x))$  does not intersect  $Q$ . Conversely, if  $p_1^{-1}(\delta_1)$  intersects  $p_2^{-1}(\delta_2)$ , then take  $U_{\delta_i}$  to be an open half-plane in  $\tilde{S}$  with bounded Hausdorff distance from  $p_i^{-1}(\delta_i)$ , where  $U_{\delta_i}$  is bounded by a geodesic in  $\tilde{\lambda}_i$ . As  $p_1^{-1}(\delta_1)$  has nonempty intersection with  $p_2^{-1}(\delta_2)$ , so do  $U_{\delta_1}$  and  $U_{\delta_2}$ . Moreover, there exists an  $h \in \pi_1 S$  whose axis  $\gamma$  intersects the pair of geodesics bounding  $U_{\delta_1}$  and  $U_{\delta_2}$ . Then  $h$  is hyperbolic in both  $T_1$  and  $T_2$ , and  $h$  makes  $Q$  heavy. □

**Remark** This characterization of the core of two trees is particularly useful in our setting. When the trees come from a pair of dual measured laminations, the map  $p = p_1 \times p_2$  has the same image as the map which sends  $\mathbb{H}^2$  to the corresponding leaf space of each of the measured foliations. However, the map defined above is not quite projection to the leaf space when the two laminations are not dual. One has to refine the pair of laminations to  $\lambda_1^r, \lambda_2^r$ , so that each now has the same support as  $\text{supp}(\lambda_1) \cup \text{supp}(\lambda_2)$ . We describe the measure on  $\lambda_1^r$  by describing the case where  $\lambda_1$  and  $\lambda_2$  are a collection of simple closed curves. To  $\lambda_1$  we add the weighted curves in  $\lambda_2$  not in  $\lambda_1$  and vice versa for  $\lambda_2^r$ . We now take the image of the projection of  $\mathbb{H}^2$  onto the leaf space of the trees dual to  $\lambda_i^r$ , followed by projection of the tree  $T_i^r$  to  $T_i$ . This map now has image coinciding with the core. This slight modification is required to ensure the core is one-dimensional when the laminations have no transverse intersection; see [18, Theorem 6.1].

We present our next main result concerning the relation between the mixed structures we obtain as limits of the induced metrics and the limits of the corresponding graphs of the minimal lagrangians.

**Theorem 6.13** *Suppose  $C_n \rightarrow \infty$ , so that  $L_{\sigma_n e_n / C_n} \rightarrow \eta$  and  $X_{1,n} / C_n \rightarrow T_1$  and  $X_{2,n} / C_n \rightarrow T_2$ . Then the metric space  $X_\eta$  is isometric to the core of the pair of trees  $(T_1, T_2)$ . Consequently, the minimal lagrangians  $\tilde{\Sigma}_n / C_n \subset \mathbb{H}^2 / C_n \times \mathbb{H}^2 / C_n$  converge geometrically to the core  $\mathcal{C}(T_1 \times T_2) \subset T_1 \times T_2$ .*

**Proof** Define the auxiliary map  $\Psi: \text{P}(\text{ML} \times \text{ML}) \rightarrow \text{PMix}(S)$  by

$$\Psi([\lambda_1, \lambda_2]) = \lim_{n \rightarrow \infty} [L_{\sigma_n e_n}],$$

where  $\Sigma_n \subset X_{1,n} \times X_{2,n}$  is the minimal lagrangian with induced metric  $2\sigma_n e_n$  and the  $(X_{1,n}, X_{2,n})$  converge projectively to  $[(\lambda_1, \lambda_2)]$ . We claim the map is well-defined.

Choose  $[(\lambda_1, \lambda_2)] \in \text{P}(\text{ML} \times \text{ML})$  and a representative  $(\lambda_1, \lambda_2) \in [(\lambda_1, \lambda_2)]$ . Then if both  $(X_{1,n}/k_n, X_{2,n}/k_n)$  and  $(Y_{1,n}/d_n, Y_{2,n}/d_n)$  converge in length spectrum to  $(\lambda_1, \lambda_2)$ , then for large enough  $n$ , we will have that  $X_{1,n}/k_n$  will be close to  $Y_{1,n}/d_n$  as negatively curved Riemannian surfaces (and likewise for  $X_{2,n}/k_n$  and  $Y_{2,n}/d_n$ ) by [33]. Hence the induced metrics on the respective pairs of minimal lagrangians will have close length spectra, so that  $\Psi$  is well-defined.

To see that  $\Psi$  is continuous, observe that the induced metric on the minimal surface varies continuously as a map defined on  $\mathcal{T}(S) \times \mathcal{T}(S)$ , and since the length spectrum of

the induced metric varies continuously as one takes a sequence of hyperbolic surfaces  $(X_{1,n}, X_{2,n}) \rightarrow [(\lambda_1, \lambda_2)] \in P(\text{ML} \times \text{ML})$ , one finds the space of mixed structures varies continuously on  $P(\text{ML} \times \text{ML})$  by a diagonal argument.

But we now have a union of harmonic maps from  $X_\eta$  to  $T_1 \times T_2$ . From Theorem 6.5, the harmonic map on the flat part is given by projection to its vertical and horizontal lamination. By Theorem 6.11, the harmonic map from the laminar part is given by an affine map, when both trees come from Jenkins–Strebel differentials.

As the homotopy classes of the maps were given by the identity map, one sees that vertices on the domain graph are mapped to the vertices of the target graph—the thick regions of the minimal surface are necessarily mapped to the thick regions of the target scaled hyperbolic surface; for if a vertex were to be mapped away from vertices, the approximating thick region of the minimal surface would be mapped deep into a thin region of the target scaled hyperbolic surface, so that the thick region of the minimal surface would not have diameter going to zero, contradicting the geometric convergence of the thick region to a vertex. Hence by Theorem 6.9, the map is an affine map which maps vertices to the corresponding vertices.

But this yields the product metric for the core of the two trees; see Proposition 6.12 and the remark which follows. The equality of the metric space associated to the mixed structure and the core of the trees then holds for pairs of  $\mathbb{R}$ -trees dual to a pair of Jenkins–Strebel foliations, which is a dense set in  $P(\text{ML} \times \text{ML})$ , and both quantities vary continuous for  $P(\text{ML} \times \text{ML})$ , thus the theorem follows.  $\square$

## 7 Applications to maximal surfaces in $\text{AdS}^3$

In this section, we prove the required analogues of the minimal lagrangian setting to show a similar result for limits of maximal surfaces.

**Proposition 7.1** *On a fixed hyperbolic surface  $(S, \sigma)$  one has  $\mathcal{H}_1 = \mathcal{H}_2$  if and only if  $e_1 = e_2$ .*

**Proof** If  $e_1 = e_2$ , then  $|\Phi_1| = |\Phi_2|$  by Lemma 4.5. From  $|\Phi_1| = |\Phi_2|$ , one has by some basic algebra,  $\mathcal{L}_2 = \mathcal{H}_1 \mathcal{L}_1 / \mathcal{H}_2$ . From the Bochner formula, one has

$$\begin{aligned} \Delta \log \mathcal{H} &= 2\mathcal{H} - 2\mathcal{L} - 2, \\ \frac{1}{2} \Delta \log \frac{\mathcal{H}_1}{\mathcal{H}_2} &= (\mathcal{H}_1 - \mathcal{H}_2) - (\mathcal{L}_1 - \mathcal{L}_2) = (\mathcal{H}_1 - \mathcal{H}_2) - \mathcal{L}_1 \left(1 - \frac{\mathcal{H}_1}{\mathcal{H}_2}\right). \end{aligned}$$

At a point  $p \in S$  for which the quotient  $\mathcal{H}_1/\mathcal{H}_2$  achieves its maximum (which without loss of generality we may assume to be greater than 1, or else as before we may re-index), the left-hand side of the preceding calculation must be nonpositive, but the right-hand side is positive, hence  $\mathcal{H}_1 = \mathcal{H}_2$  everywhere.  $\square$

**Proposition 7.2** *On a fixed hyperbolic surface  $(S, \sigma)$ , if  $\mathcal{H}_1 = c\mathcal{H}_2$  then  $c = 1$ .*

**Proof** Without loss of generality, take  $c > 1$  or we may re-index to ensure this is the case. Once again by the Bochner formula,

$$\begin{aligned}\Delta \log \frac{\mathcal{H}_1}{\mathcal{H}_2} &= 2(\mathcal{H}_1 - \mathcal{H}_2) - 2(\mathcal{L}_1 - \mathcal{L}_2), \\ 0 = \Delta \log c &= 2(c\mathcal{H}_2 - \mathcal{H}_2) - 2(\mathcal{L}_1 - \mathcal{L}_2) = 2\mathcal{H}_2(c - 1) - 2(\mathcal{L}_1 - \mathcal{L}_2).\end{aligned}$$

Hence, everywhere one has

$$\mathcal{L}_1 - \mathcal{L}_2 = \mathcal{H}_2(c - 1) > 0.$$

But  $\mathcal{L}_1$  vanishes at the zeros of the quadratic differential  $\Phi_1$ , a contradiction. Hence  $c = 1$ .  $\square$

**Proposition 7.3** *Let  $H = \int \mathcal{H} dA(\sigma)$ . Then  $\mathcal{E} = 2H + 4\pi\chi$ . Consequently, if  $\mathcal{E}_n \rightarrow \infty$ , then  $\lim_{n \rightarrow \infty} \mathcal{E}_n/H_n = 2$ .*

**Proof** As  $\mathcal{J} = \mathcal{H} - \mathcal{L}$  and  $\int \mathcal{J}\sigma dz d\bar{z} = -2\pi\chi$ , one has

$$\int \mathcal{H}\sigma dz d\bar{z} + 2\pi\chi = \int \mathcal{L}\sigma dz d\bar{z}.$$

Adding the terms yields

$$\mathcal{E} = \int (\mathcal{H} + \mathcal{L})\sigma dz d\bar{z} = 2 \int \mathcal{H}\sigma dz d\bar{z} + 4\pi\chi = 2H + 4\pi\chi. \quad \square$$

Recall from Section 2.6 the existence and uniqueness of a spacelike, embedded maximal surface in any GHMC AdS<sup>3</sup> manifold.

**Proposition 7.4** [22, Lemma 3.6] *The induced metric on the maximal surface is of the form  $\mathcal{H}\sigma$ .*

**Proposition 7.5** *The induced metric on the maximal surface has strictly negative curvature.*

**Proof** The formula for curvature is given by

$$K_{\mathcal{H}\sigma} = -\frac{1}{2\mathcal{H}\sigma} \Delta \log \mathcal{H}\sigma = -\frac{1}{2} \frac{1}{\mathcal{H}} \left( \frac{\Delta \log \mathcal{H}}{\sigma} + \frac{\Delta \log \sigma}{\sigma} \right) = \frac{-\mathcal{J}}{\mathcal{H}},$$

where the last step comes from the Bochner equation and the curvature of the hyperbolic metric. □

**Theorem 7.6** *There exists an embedding of the space of maximal surfaces into the space of projectivized currents.*

**Proof** As the induced metrics on the maximal surfaces are negatively curved, they may be realized as geodesic currents. By Proposition 7.2, the projectivization remains injective. □

**Theorem 7.7** *The closure of the space of induced metrics on the maximal surfaces is given by the space of flat metrics arising from unit-norm holomorphic quadratic differentials and projectivized mixed structures.*

**Proof** To any induced metric  $\mathcal{H}\sigma$  on the maximal surface, there is a unique singular quadratic differential metric  $|\Phi|$  associated to it. Some algebra shows that

$$\mathcal{H}\sigma = \frac{|\Phi|}{|v|} \geq |\Phi|,$$

which for high energy, Proposition 7.3 tells us  $H$  approximates the  $L^1$ -norm of the quadratic differential, so that if the sequence of unit-norm quadratic differentials converges to measured lamination, then so does the projective current associated to the induced metric on the maximal surface. (If the energy is bounded, an adaptation of the proof of Proposition 5.4 shows that the limit of induced metrics will be a measured lamination.) Hence, we assume the sequence of unit-norm quadratic differential metrics converges to a mixed structure. On the flat part of the mixed structure, from the proof of Proposition 5.12 we know that up to a subsequence the Beltrami differentials converge uniformly to 1 outside of a small region about the zeros of the differential and a cylindrical neighborhood of the boundary curves. But then we know that on this subsurface the maximal surface metric will converge to  $|\Phi_\infty|$  in terms of its length spectrum. As the total area of the mixed structure is 1 and we have normalized the maximal surface metric by the total holomorphic energy, on the complement, the area of the metric tends to 0, so that the restriction of the limiting current is a measured lamination. □

We observe there is a rather interesting trichotomy at play here. For high energy, on the subsurface  $S'$ , if the quadratic differentials converge to  $|\Phi_\infty|$  then so do the associated sequence of minimal surface metrics and the sequence of maximal surface metrics.

## 8 Compactification of maximal representations to $\mathrm{PSL}(2, \mathbb{R}) \times \mathrm{PSL}(2, \mathbb{R})$

In this final section, we provide an application of our work to compactifying the maximal component of the character variety  $\chi(\mathrm{PSL}(2, \mathbb{R}) \times \mathrm{PSL}(2, \mathbb{R}))$ . The theory of maximal representations is defined for general Hermitian Lie groups  $G$  and is considerably more straightforward to define in our specific setting of  $G = \mathrm{PSL}(2, \mathbb{R}) \times \mathrm{PSL}(2, \mathbb{R})$ . Nevertheless, we will define a maximal representation in the general setting before providing a straightforward characterization in our setting.

Let  $G$  be a *Hermitian* Lie group, that is, a noncompact simple Lie group whose symmetric space  $G/K$  is a Kähler manifold. Equivalently, there is a  $G$ -invariant two-form  $\omega$  on  $G/K$ . Let  $S$  be a closed, orientable, smooth surface of genus  $g \geq 2$ . Then given a representation  $\rho: \pi_1 S \rightarrow G$ , there is a  $\rho$ -equivariant map  $\tilde{f}: \tilde{S} \rightarrow G/K$  defined by taking any smooth section of the flat bundle  $E_\rho = \tilde{S} \times_\rho G/K \rightarrow S$ . Define the *Toledo invariant* to be

$$T(\rho) := \frac{1}{2\pi} \int_S \tilde{f}^* \omega.$$

The Toledo invariant will be well-defined for each such representation as the number obtained will not depend on the choice of section chosen above; a different section would yield another map differing by a  $\rho$ -equivariant homotopy, giving the same number. A well-known *Milnor–Wood* type inequality holds for the Toledo invariant,

$$|T(\rho)| \leq |\chi(S)| \cdot \mathrm{rank}(G/K).$$

Representations whose Toledo invariant attains the upper bound are known as *maximal representations*. We now restrict our attention specifically to the group  $G = \mathrm{PSL}(2, \mathbb{R}) \times \mathrm{PSL}(2, \mathbb{R})$ , whose associated symmetric space is  $\mathbb{H}^2 \times \mathbb{H}^2$ .

For each representation to the group  $\mathrm{PSL}(2, \mathbb{R}) \times \mathrm{PSL}(2, \mathbb{R})$ , one obtains a pair of representations to the group  $\mathrm{PSL}(2, \mathbb{R})$ . By work of Goldman [17], the Euler number of representations to  $\mathrm{PSL}(2, \mathbb{R})$  characterizes the connected components of the representation variety. The maximal representations are precisely those whose projections live in the Hitchin component of  $\mathrm{PSL}(2, \mathbb{R})$  representations, that is, those



representations that are both discrete and faithful. Hence, such a representation yields a pair of points in Teichmüller space and an associated minimal surface. We may parametrize such representations by the equivariant minimal lagrangian in  $\mathbb{H}^2 \times \mathbb{H}^2$  from Theorem 3.1. As a final consequence of our study of these minimal lagrangians, we obtain a compactification of the maximal component of surface group representations to  $\mathrm{PSL}(2, \mathbb{R}) \times \mathrm{PSL}(2, \mathbb{R})$ .

**Theorem 8.1** *Let  $S$  be a closed surface of genus  $g > 1$ . The space of maximal representations of  $\pi_1(S)$  to  $\mathrm{PSL}(2, \mathbb{R}) \times \mathrm{PSL}(2, \mathbb{R})$  embeds into the space of  $\pi_1 S$ -equivariant minimal lagrangians in  $\mathbb{H}^2 \times \mathbb{H}^2$ . The scaled Gromov–Hausdorff limits of the minimal lagrangians are given by cores in the product  $T_1 \times T_2$  of trees, where  $T_1$  and  $T_2$  are a pair of  $\mathbb{R}$ -trees coming from a projective pair of measured foliations.*

**Proof** For any maximal representation  $\rho = (\rho_1, \rho_2)$ , we may look at the two closed hyperbolic surfaces given by  $X_1 = \mathbb{H}^2 \setminus \rho_1$  and  $X_2 = \mathbb{H}^2 \setminus \rho_2$ . This gives a clear homeomorphism between the maximal component and two copies of Teichmüller space and thus, by Theorem 3.3, to the bundle of holomorphic quadratic differentials over Teichmüller space. By Theorem 3.1, we obtain a minimal lagrangian between  $X_1$  and  $X_2$  which respects the marking. Taking the lift gives a  $\pi_1 S$ -equivariant minimal lagrangian in  $\mathbb{H}^2 \times \mathbb{H}^2$ . As distinct representations have distinct minimal lagrangians (distinguished by both the metric via Corollary 4.6 and the second fundamental form via Proposition 4.3), we have our desired embedding.

If  $\rho_n = (\rho_{1,n}, \rho_{2,n})$  is a sequence of representations leaving all compact sets, then there exists a sequence of constants  $C_n \rightarrow \infty$  such that passing to a subsequence one has  $\tilde{X}_{1,n}/C_n \rightarrow T_1$  and  $\tilde{X}_{2,n}/C_n \rightarrow T_2$ , where  $T_1$  and  $T_2$  are both  $\mathbb{R}$ -trees, and at most one of the trees is just a single vertex. By Theorem 6.13, the Gromov–Hausdorff limit of the minimal lagrangians scaled by  $C_n$  converges to the core of the product  $T_1 \times T_2$ , which suffices for the proof.  $\square$

## References

- [1] **SI Al’ber**, *Higher-dimensional problems in global variational calculus*, Dokl. Akad. Nauk SSSR 156 (1964) 727–730 MR Zbl In Russian; translated in Sov. Math. Dokl. 5 (1964) 700–704
- [2] **T Barbot, F Béguin, A Zeghib**, *Constant mean curvature foliations of globally hyperbolic spacetimes locally modelled on  $\mathrm{AdS}_3$* , Geom. Dedicata 126 (2007) 71–129 MR Zbl

- [3] **M Bestvina**, *Degenerations of the hyperbolic space*, Duke Math. J. 56 (1988) 143–161 MR Zbl
- [4] **F Bonahon**, *The geometry of Teichmüller space via geodesic currents*, Invent. Math. 92 (1988) 139–162 MR Zbl
- [5] **M Burger, A Iozzi, A Parreau, MB Pozzetti**, *Currents, systoles, and compactifications of character varieties*, Proc. Lond. Math. Soc. 123 (2021) 565–596 MR Zbl
- [6] **M Burger, A Iozzi, A Parreau, MB Pozzetti**, *Weyl chamber length compactification of the  $\mathrm{PSL}(2, \mathbb{R}) \times \mathrm{PSL}(2, \mathbb{R})$  maximal character variety*, preprint (2021) arXiv 2112.13624
- [7] **A J Casson, SA Bleiler**, *Automorphisms of surfaces after Nielsen and Thurston*, London Mathematical Society Student Texts 9, Cambridge Univ. Press (1988) MR Zbl
- [8] **G Daskalopoulos, S Dostoglou, R Wentworth**, *Character varieties and harmonic maps to  $\mathbb{R}$ -trees*, Math. Res. Lett. 5 (1998) 523–533 MR Zbl
- [9] **M Duchin, C J Leininger, K Rafi**, *Length spectra and degeneration of flat metrics*, Invent. Math. 182 (2010) 231–277 MR Zbl
- [10] **J Eells, B Fuglede**, *Harmonic maps between Riemannian polyhedra*, Cambridge Tracts in Mathematics 142, Cambridge Univ. Press (2001) MR Zbl
- [11] **J Eells, Jr, JH Sampson**, *Harmonic mappings of Riemannian manifolds*, Amer. J. Math. 86 (1964) 109–160 MR Zbl
- [12] **A Fathi, F Laudenbach, V Poénaru**, *Thurston’s work on surfaces*, Mathematical Notes 48, Princeton Univ. Press (2012) MR Zbl
- [13] **J Frazier**, *Length spectral rigidity of non-positively curved surfaces*, PhD thesis, University of Maryland, College Park (2012) MR Available at <https://www.proquest.com/docview/1033322768>
- [14] **D Gilbarg, NS Trudinger**, *Elliptic partial differential equations of second order*, Grundlehr. Math. Wissen. 224, Springer (1977) MR Zbl
- [15] **O Glorieux**, *Counting closed geodesics in globally hyperbolic maximal compact AdS 3-manifolds*, Geom. Dedicata 188 (2017) 63–101 MR Zbl
- [16] **O Glorieux**, *The embedding of the space of negatively curved surfaces in geodesic currents*, preprint (2019) arXiv 1904.02558
- [17] **WM Goldman**, *Discontinuous groups and the Euler class*, PhD thesis, University of California, Berkeley (1980) MR Available at <https://www.proquest.com/docview/302998874>
- [18] **V Guirardel**, *Cœur et nombre d’intersection pour les actions de groupes sur les arbres*, Ann. Sci. École Norm. Sup. 38 (2005) 847–888 MR Zbl
- [19] **P Hartman**, *On homotopic harmonic maps*, Canadian J. Math. 19 (1967) 673–687 MR Zbl

- [20] **N J Korevaar, R M Schoen**, *Sobolev spaces and harmonic maps for metric space targets*, *Comm. Anal. Geom.* 1 (1993) 561–659 MR Zbl
- [21] **N J Korevaar, R M Schoen**, *Global existence theorems for harmonic maps to non-locally compact spaces*, *Comm. Anal. Geom.* 5 (1997) 333–387 MR Zbl
- [22] **K Krasnov, J-M Schlenker**, *Minimal surfaces and particles in 3-manifolds*, *Geom. Dedicata* 126 (2007) 187–254 MR Zbl
- [23] **F Labourie**, *Cross ratios, Anosov representations and the energy functional on Teichmüller space*, *Ann. Sci. Éc. Norm. Supér.* 41 (2008) 437–469 MR Zbl
- [24] **F Labourie**, *Cyclic surfaces and Hitchin components in rank 2*, *Ann. of Math.* 185 (2017) 1–58 MR Zbl
- [25] **E Lebeau**, *Applications harmoniques entre graphes finis et un théorème de superrigidité*, *Ann. Inst. Fourier (Grenoble)* 46 (1996) 1183–1203 MR Zbl
- [26] **G Martone, C Ouyang, A Tamburelli**, *A closed ball compactification of a maximal component via cores of trees*, preprint (2021) arXiv 2110.06106
- [27] **C McMullen**, *Amenability, Poincaré series and quasiconformal maps*, *Invent. Math.* 97 (1989) 95–127 MR Zbl
- [28] **G Mess**, *Lorentz spacetimes of constant curvature*, *Geom. Dedicata* 126 (2007) 3–45 MR Zbl
- [29] **Y N Minsky**, *Harmonic maps, length, and energy in Teichmüller space*, *J. Differential Geom.* 35 (1992) 151–217 MR Zbl
- [30] **J W Morgan**, *Group actions on trees and the compactification of the space of classes of  $SO(n, 1)$ -representations*, *Topology* 25 (1986) 1–33 MR Zbl
- [31] **J W Morgan, P B Shalen**, *Valuations, trees, and degenerations of hyperbolic structures, I*, *Ann. of Math.* 120 (1984) 401–476 MR Zbl
- [32] **J W Morgan, P B Shalen**, *Free actions of surface groups on  $\mathbb{R}$ -trees*, *Topology* 30 (1991) 143–154 MR Zbl
- [33] **J-P Otal**, *Le spectre marqué des longueurs des surfaces à courbure négative*, *Ann. of Math.* 131 (1990) 151–162 MR Zbl
- [34] **C Ouyang, A Tamburelli**, *Limits of Blaschke metrics*, *Duke Math. J.* 170 (2021) 1683–1722 MR Zbl
- [35] **C Ouyang, A Tamburelli**, *Length spectrum compactification of the  $SO_0(2, 3)$ -Hitchin component*, *Adv. Math.* 420 (2023) art. id. 108997 MR Zbl
- [36] **C Ouyang, A Tamburelli**, *Boundary of the Gothen components*, *Topology Appl.* 326 (2023) art. id. 108420 MR Zbl
- [37] **R C Penner, J L Harer**, *Combinatorics of train tracks*, *Annals of Mathematics Studies* 125, Princeton Univ. Press (1992) MR Zbl

- [38] **J H Sampson**, *Some properties and applications of harmonic mappings*, Ann. Sci. École Norm. Sup. 11 (1978) 211–228 MR Zbl
- [39] **R M Schoen**, *The role of harmonic mappings in rigidity and deformation problems*, from “Complex geometry” (G Komatsu, Y Sakane, editors), Lecture Notes in Pure and Appl. Math. 143, Dekker, New York (1993) 179–200 MR Zbl
- [40] **R Schoen, S T Yau**, *On univalent harmonic maps between surfaces*, Invent. Math. 44 (1978) 265–278 MR Zbl
- [41] **R K Skora**, *Splittings of surfaces*, J. Amer. Math. Soc. 9 (1996) 605–616 MR Zbl
- [42] **W P Thurston**, *On the geometry and dynamics of diffeomorphisms of surfaces*, Bull. Amer. Math. Soc. 19 (1988) 417–431 MR Zbl
- [43] **A Wienhard**, *An invitation to higher Teichmüller theory*, from “Proceedings of the International Congress of Mathematicians” (B Sirakov, P N de Souza, M Viana, editors), volume 2, World Sci., Hackensack, NJ (2018) 1013–1039 MR Zbl
- [44] **M Wolf**, *The Teichmüller theory of harmonic maps*, J. Differential Geom. 29 (1989) 449–479 MR Zbl
- [45] **M Wolf**, *High energy degeneration of harmonic maps between surfaces and rays in Teichmüller space*, Topology 30 (1991) 517–540 MR Zbl
- [46] **M Wolf**, *Harmonic maps from surfaces to  $\mathbb{R}$ -trees*, Math. Z. 218 (1995) 577–593 MR Zbl

Department of Mathematics, Washington University  
St Louis, MO, United States

ouyang@math.wustl.edu

Proposed: Anna Wienhard  
Seconded: Tobias H Colding, Mladen Bestvina

Received: 6 January 2020  
Revised: 25 July 2021

# Orbifold bordism and duality for finite orbispectra

JOHN PARDON

We construct the stable (representable) homotopy category of *finite orbispectra*, whose objects are formal desuspensions of finite orbi-CW-pairs by vector bundles and whose morphisms are stable homotopy classes of (representable) relative maps. The stable representable homotopy category of finite orbispectra admits a contravariant involution extending Spanier–Whitehead duality. This duality relates homotopical cobordism theories (cohomology theories on finite orbispectra) represented by global Thom spectra to geometric (derived) orbifold bordism groups (homology theories on finite orbispectra). This isomorphism extends the classical Pontryagin–Thom isomorphism and its known equivariant generalizations.

55M05, 55P25, 55P42, 55P91, 57R85; 55N91, 55Q91, 55R91, 55U30, 57R91

1. Introduction	1747
2. Topology of orbispaces	1759
3. Homotopy theory of orbispaces	1775
4. Vector bundles	1807
5. Orbifold bordism	1814
6. Global homotopy theory	1828
7. Bordism and stable maps	1839
References	1842

## 1 Introduction

The classical Pontryagin–Thom isomorphism [30; 31; 37] equates manifold bordism groups  $\Omega_*(X)$  with corresponding stable homotopy groups  $[S, X \wedge MO]$  for spaces  $X$ . When  $X$  is a  $G$ -space ( $G$  a compact Lie group), equivariant versions of this isomorphism are well-studied; see for instance Bröcker and Hook [6], Conner and Floyd [10], Schwede [34], Wasserman [38] and tom Dieck [11].

A main result of this paper is to construct the Pontryagin–Thom isomorphism in the homotopy theory of *orbispaces*, as developed in Haefliger [20]. The basic objects of this homotopy theory are *orbi-CW-complexes*, which are built like CW-complexes by attaching cells of the form  $(D^k, \partial D^k) \times \mathbf{B}G$  for finite groups  $G$  along *representable* maps; see Gepner and Henriques [18]. (The more general setting in which one allows compact Lie groups in place of finite groups is unfortunately beyond the scope of this paper, most significantly due to the failure of “enough vector bundles” in this context.) The most familiar instance of orbispaces in topology is probably orbifolds; moduli spaces of solutions to elliptic partial differential equations, as they appear in low-dimensional and symplectic topology, are also best regarded as orbispaces, and they provide some of the motivation for our present investigation.

The Pontryagin–Thom isomorphism relates “geometric bordism theories” with “homotopical cobordism theories” for orbispaces  $X$ . In our setting, the relevant geometric bordism theories  $\Omega_*(X)$  are given by bordism classes of (possibly “derived”) orbifolds with a representable map to  $X$  (and possibly with some sort of tangential structure). The homotopical cobordism theories relevant for us are those associated to the global Thom spectra defined by Schwede [34]. These theories (on both the geometric side and the homotopical side) come in two flavors; on the geometric side, these correspond to the adjectives “ordinary” and “derived”. The difference between ordinary and derived bordism measures the failure of equivariant transversality.

The Pontryagin–Thom isomorphism between geometric bordism and homotopical cobordism passes through the category of *finite representable orbispectra* and a contravariant “duality” involution on this category. The construction of this category and of its involution are our remaining main results. They both rely crucially on the fact, proven in Pardon [29], that compact orbispaces admit “enough vector bundles” — the assertion that a given compact orbi-CW-complex  $X$  admits enough vector bundles is equivalent to the assertion that  $X$  is homotopy equivalent to a compact effective orbifold with boundary; *effective* means that in the local models  $\mathbb{R}^n/G$  or  $(\mathbb{R}^{n-1} \times \mathbb{R}_{\geq 0})/G$ , the homomorphism  $G \rightarrow \mathrm{GL}_n(\mathbb{R})$  is *injective*. Enough vector bundles also underlies much of the other reasoning in this paper, including the definition of derived orbifold bordism groups, the extension of geometric bordism theories to orbispectra, and the relation between orbi-CW-complexes and the global homotopy theory from [34].

Before stating our main results more formally, we give a concrete example to motivate the more abstract discussion which follows.

**Example 1.1** We describe a stable homotopy theoretic realization of the bordism group of closed orbifolds, which for reasons which will become apparent shortly, we denote by  $\Omega_*(R(*))$ . This group has been studied by Druschel [13; 14; 15], Ángel [1; 2] and Sarkar [33].

The first main point of the Pontryagin–Thom construction for manifolds is to note that every manifold  $M$  admits a homotopically unique embedding into  $\mathbb{R}^N$  as  $N \rightarrow \infty$ , in the sense that the space of embeddings  $M \hookrightarrow \mathbb{R}^N$  becomes highly connected in the limit  $N \rightarrow \infty$ . We therefore seek a corresponding sequence of orbifolds  $X_N$  with the property that every orbifold  $M$  admits a homotopically unique embedding into  $X_N$  in the limit  $N \rightarrow \infty$ . In this pursuit, it is helpful to separate the two key properties of  $\mathbb{R}^N$  which give rise to the unique embedding property for manifolds: it is contractible (so everything has a homotopically unique map to it) and high-dimensional (so the locus of maps which are not embeddings has arbitrarily high codimension as  $N \rightarrow \infty$ ).

Now if we are seeking an embedding of orbifolds  $M \hookrightarrow X_N$ , we should first note that an embedding is necessarily *representable*, so we should not seek  $X_N$  which are contractible, rather we should seek  $X_N$  with the property that the space of *representable* maps to  $X_N$  is contractible (for every domain orbispace). This universal property defines a unique homotopy type, which we denote by

$$(1-1) \quad R(*) := \bigsqcup_{G_0 \hookrightarrow \dots \hookrightarrow G_p} \mathbf{B}G_0 \times \Delta^p / \sim,$$

where the right side is modeled on the nerve of the 2–category of finite groups, injective maps and conjugations. It is straightforward to check that  $R(*)$  has the desired property: it is enough (by an obstruction theory argument) to show that the space of representable maps  $\mathbf{B}G \rightarrow R(*)$  is contractible for every finite group  $G$ , and this space is

$$(1-2) \quad \bigsqcup_{G_0 \hookrightarrow \dots \hookrightarrow G_p} \widetilde{\text{RepMaps}}(\mathbf{B}G, \mathbf{B}G_0) \times \Delta^p / \sim = \bigsqcup_{G \hookrightarrow G_0 \hookrightarrow \dots \hookrightarrow G_p} \Delta^p / \sim,$$

which is contractible as it is the nerve of a category with an initial object (the undercategory of  $G$  in the 2–category of finite groups, injective maps and conjugations). Thus, in particular, every compact orbifold  $M$  admits a homotopically unique representable map  $M \rightarrow R(*)$ .

Next, we should realize  $R(*)$  as a high-dimensional orbifold so as to ensure that the locus of representable maps  $M \rightarrow R(*)$  which fail to be an embedding has arbitrarily large codimension inside the space of all maps (in fact, to guarantee this, we need more

than just that the dimension of  $R(*)$  is large, rather we need that when its tangent bundle is decomposed into isotypic pieces with respect to the isotropy group actions, every isotypic piece has high dimension). Filter  $R(*)$  by finite subcomplexes, and use enough vector bundles [29] to realize each as a compact effective orbifold with boundary; moreover, use enough vector bundles again to replace each with the total space of the unit disk bundle of a vector bundle over it, whose isotypic pieces are all high-dimensional. We thus get a sequence of compact orbifolds with boundary and smooth embeddings  $X_0 \hookrightarrow X_1 \hookrightarrow X_2 \hookrightarrow \dots$ , such that for every closed orbifold  $M$ , the direct limit over  $i \rightarrow \infty$  of the space of embeddings  $M \hookrightarrow X_i$  is contractible.

There is now an obvious Pontryagin–Thom collapse map giving, for any smooth suborbifold of  $X_i$  of dimension  $d$ , an element of  $\mathbf{mO}^{-d}((X_i, \partial X_i)^{-TX_i})$ , where  $\mathbf{mO}$  is the global spectrum defined by Schwede [34] — we define the category of orbispectra which includes expressions such as  $(X_i, \partial X_i)^{-TX_i}$  as objects, and we show that global spectra define cohomology theories on orbispectra. The homotopically unique embedding property of the sequence  $X_0 \hookrightarrow X_1 \hookrightarrow X_2 \hookrightarrow \dots$  thus gives us a map  $\Omega_*(R(*)) \rightarrow \varinjlim_{i \rightarrow \infty} \mathbf{mO}^{-*}((X_i, \partial X_i)^{-TX_i})$ . Now Theorem 1.3 defines an involution  $D$  on the category of orbispectra which sends  $X_i$  to  $(X_i, \partial X_i)^{-TX_i}$ , so we may formulate the Pontryagin–Thom map more intrinsically as

$$(1-3) \quad \Omega_*(R(*)) \rightarrow \mathbf{mO}^{-*}(D(R(*))),$$

where to be completely precise we should remark that  $D$  is defined only on the category of finite orbispectra, so  $D(R(*))$  is really an inverse system of orbispectra, to which applying the contravariant functor  $\mathbf{mO}^{-*}$  yields a directed system of graded abelian groups, and the right side above refers to its direct limit. Theorem 1.4 states that this Pontryagin–Thom map is an isomorphism (for any orbispectrum in place of  $R(*)$ ). We thus conclude that the group of closed orbifolds modulo bordism is  $\mathbf{mO}^{-*}(D(R(*)))$ .

## 1.1 Categories of orbispaces

We approach the homotopy theory of orbispaces from the point of view of orbi-CW-complexes; these are built like CW-complexes from cells  $(D^k, \partial D^k) \times \mathbf{B}G$  for integers  $k \geq 0$  and finite groups  $G$ , which are attached along *representable* maps — this is a slight adaptation of a definition given by Gepner and Henriques [18]. We denote by  $\mathbf{Spc}$  the category of CW-complexes and homotopy classes of maps, and we denote by  $\mathbf{OrbSpc}$  (resp.  $\mathbf{RepOrbSpc}$ ) the category of orbi-CW-complexes and homotopy classes



of all (resp. representable) maps. There are thus functors

$$(1-4) \quad \text{Spc} \rightarrow \text{RepOrbSpc} \rightarrow \text{OrbSpc},$$

with  $\text{Spc}$  being a full subcategory of both  $\text{RepOrbSpc}$  and  $\text{OrbSpc}$ . It was pointed out already by Gepner and Henriques [18] that the distinction between representable and all maps leads to two distinct theories, both of which can legitimately be called “the homotopy theory of orbispaces”.

The functor  $\text{Spc} \rightarrow \text{OrbSpc}$  has a left adjoint  $X \mapsto |X|$  (the coarse space of  $X$ ) and a right adjoint  $X \mapsto \tilde{X}$  (the classifying space of  $X$ ). The functor  $\text{RepOrbSpc} \rightarrow \text{OrbSpc}$  also has a right adjoint, which we denote by  $X \mapsto R(X)$ . The orbi-CW-complex  $R(*)$  plays a recurring role in our discussion; it is the terminal object of  $\text{RepOrbSpc}$ , and it is what Rezk [32] calls the *normal subgroup classifier*  $\mathcal{N}$ .

**Remark 1.2** We certainly expect, but do not pursue here,  $\infty$ -categorical refinements of all of our constructions. This expectation is reflected in our notation: although all of the categories under consideration in this paper are homotopy categories, we do not include the prefix  $\text{Ho}$  in their notation.

Of importance are also the categories of *relative orbi-CW-complexes*  $\text{RepOrbSpc}_*$  and  $\text{OrbSpc}_*$ , which are analogues of the category  $\text{Spc}_*$  of pointed CW-complexes. It should be noted, however, that  $\text{RepOrbSpc}_*$  and  $\text{OrbSpc}_*$  are not the homotopy categories of pointed orbi-CW-complexes; rather, their objects are orbi-CW-pairs  $(X, A)$  — meaning  $X$  is an orbi-CW-complex and  $A \subseteq X$  is a subcomplex — with a nontrivial notion of morphism. The essential reason this slightly complicated definition is needed is that for an orbi-CW-pair  $(X, A)$ , there is no good way to collapse  $A$  to a point and form a quotient orbi-CW-complex  $X/A$ . We have functors

$$(1-5) \quad \text{Spc}_* \rightarrow \text{RepOrbSpc}_* \rightarrow \text{OrbSpc}_*,$$

again with  $\text{Spc}_*$  being a full subcategory of the latter two, and there is a natural map from (1-4) to (1-5) given by adjoining a disjoint basepoint.

The categories  $\text{RepOrbSpc}$  and  $\text{RepOrbSpc}_*$  are a natural setting for homotopy theory. The category  $\text{RepOrbSpc}_*$  has a natural notion of a cofiber sequence  $X \rightarrow Y \rightarrow Z$ , and every morphism  $X \rightarrow Y$  in  $\text{RepOrbSpc}_*$  extends to a half-infinite “Puppe” sequence  $X \rightarrow Y \rightarrow Z \rightarrow \Sigma X \rightarrow \Sigma Y \rightarrow \Sigma Z \rightarrow \Sigma^2 X \rightarrow \dots$ , in which every consecutive triple is a cofiber sequence.

The natural functor  $\text{RepOrbSpc} \rightarrow \text{PSh}(\text{Rep}\{\mathbf{BG}\})$  (at the level of  $\infty$ -categories or model categories) is an equivalence by Gepner and Henriques [18], where  $\text{Rep}\{\mathbf{BG}\} \subseteq \text{RepOrbSpc}$  denotes the full subcategory spanned by the objects  $\mathbf{BG}$  for finite groups  $G$ . This means that  $\text{RepOrbSpc}$  is the free cocompletion of its full subcategory  $\text{Rep}\{\mathbf{BG}\}$ . We conjecture that  $\text{RepOrbSpc}$  is the category of representable fibrations over  $R(*)$  (here  $R$  is the right adjoint to  $\text{RepOrbSpc} \rightarrow \text{OrbSpc}$ ) with “reasonable” fibers — note that the data of a representable fibration over  $R(*)$  is at least intuitively comparable to the data of a presheaf on  $\text{Rep}\{\mathbf{BG}\}$ . Let us also remark that both these descriptions of  $\text{RepOrbSpc}$  (and the corresponding descriptions of  $\text{RepOrbSpc}_*$ ) are manifestly natural settings for doing homotopy theory, whereas proving this for  $\text{RepOrbSpc}_*$  as we define it requires a somewhat explicit argument. On the other hand, it is somewhat less apparent from these descriptions what the full subcategory of finite orbi-CW-complexes  $\text{RepOrbSpc}^f \subseteq \text{RepOrbSpc}$  is.

The categories  $\text{OrbSpc}$  and  $\text{OrbSpc}_*$  do not seem to be a natural setting for homotopy theory; for example, there are morphisms in  $\text{OrbSpc}_*$  which do not have a cofiber in any reasonable sense. Rather,  $\text{OrbSpc}$  (similarly for  $\text{OrbSpc}_*$ ) is a full subcategory of the larger category, say denoted by  $\overline{\text{OrbSpc}}$ , obtained by gluing cells  $(D^k, \partial D^k) \times \mathbf{BG}$  along all (not necessarily representable) maps, as constructed by Gepner and Henriques [18]; note that this takes us outside the realm of stacks admitting étale atlases. Gepner and Henriques [18] further showed that  $\overline{\text{OrbSpc}}$  is equivalent, again at the level of  $\infty$ -categories or model categories, to  $\text{PSh}(\{\mathbf{BG}\})$ . This latter category  $\text{PSh}(\{\mathbf{BG}\})$  was shown by Schwede [35] to be equivalent to the global homotopy category  $\text{GloSpc}$  defined in [34] (with respect to the “global family” of all finite groups); see also Körschgen [24] and Juran [21]. We will not explain in detail (nor use) the precise relationship between  $\text{OrbSpc}$  and  $\overline{\text{OrbSpc}} = \text{PSh}(\{\mathbf{BG}\}) = \text{GloSpc}$ ; rather, we describe just the little bit that we need.

## 1.2 Geometric bordism theories

We consider various flavors of geometric bordism groups, all of which are sequences of functors

$$(1-6) \quad Z_i: \text{RepOrbSpc}_* \rightarrow \text{Ab}$$

satisfying  $Z_i(\Sigma X) = Z_{i+1}(X)$  and  $\bigoplus_{\alpha} Z_i(X_{\alpha}) \xrightarrow{\sim} Z_i(\bigsqcup_{\alpha} X_{\alpha})$  and which sends cofiber sequences to exact sequences; such a functor might be called a *homology theory* for orbispaces.

The bordism group  $\Omega_*(X)$  is the set of closed orbifolds with a representable map to  $X$ , modulo bordism (graded by dimension); this is an abelian group under disjoint union. To define  $\Omega_*(X, A)$  for a pair  $(X, A)$ , consider compact orbifolds-with-boundary  $M$  and representable maps of pairs  $(M, \partial M) \rightarrow (X, A)$ . Our notation is consistent with the usual meaning of  $\Omega_*(X)$  for spaces  $X$ , namely bordism classes of closed manifolds mapping to  $X$ , since an orbifold with a representable map to a space is necessarily a manifold. Moreover,  $\Omega_*(X/G)$  is  $G$ -equivariant bordism for  $G$ -spaces  $X$ , ie bordism of  $G$ -manifolds mapping equivariantly to  $X$ .

There is no additional generality to be gained by considering arbitrary (not necessarily representable) maps here, since a map to  $X$  is the same as a representable map to  $R(X)$ , where  $R: \text{OrbSpc} \rightarrow \text{RepOrbSpc}$  is the right adjoint to  $\text{RepOrbSpc} \rightarrow \text{OrbSpc}$ , so bordism of orbifolds with an arbitrary map to  $X$  is given by  $\Omega_*(R(X))$ . For example, the group of bordism classes of closed orbifolds is  $\Omega_*(R(*))$ . Filtering  $R(*)$  by subcomplexes gives a spectral sequence converging to  $\Omega_*(R(*))$ ; see Ángel [1] for a similar spectral sequence.

There are also derived bordism groups  $\Omega_*^{\text{der}}(X)$ , whose elements are represented by “derived orbifold charts”  $(D, E, s)$  consisting of an orbifold  $D$ , a vector bundle  $E$  over  $D$ , and a section  $s: D \rightarrow E$  whose zero set is compact, together with a representable map  $D \rightarrow X$  (grading by “virtual dimension”  $\dim D - \dim E$ ). These are considered modulo restriction (removing from  $D$  a closed subset disjoint from  $s^{-1}(0)$ ), stabilization (replacing  $D$  with the total space of a vector bundle  $V$  over  $D$ , replacing  $E$  with  $E \oplus V$  and replacing  $s$  with  $s \oplus \text{id}_V$ ), and bordism.

The tautological map  $\Omega_* \rightarrow \Omega_*^{\text{der}}$  is not generally an isomorphism; in fact  $\Omega_*^{\text{der}}$  is often nonzero in negative degrees  $* < 0$ ; see Example 5.4. This can be viewed as a strong measurement of the fact that a vector bundle over an orbifold need not have any section which is transverse to zero.

That these derived bordism groups  $\Omega_*^{\text{der}}$  define a homology theory for orbispaces requires enough vector bundles. This is related to the fact that the “proper” definition of a derived orbifold is as something with an atlas of derived orbifold charts (it would be essentially obvious that bordism of these defines a homology theory for orbispaces), and enough vector bundles implies everything has a global chart.

For any vector bundle over  $X$ , there are so-called “inverse Thom maps”

$$(1-7) \quad \Omega_*(X) \rightarrow \Omega_{*+|V|}(X^V) \quad \text{and} \quad \Omega_*^{\text{der}}(X) \rightarrow \Omega_{*+|V|}^{\text{der}}(X^V),$$

with terminology following Schwede [34, Section 6]. For derived bordism, the inverse Thom maps are isomorphisms, whereas for ordinary bordism they are isomorphisms for vector bundles with trivial isotropy representations, but not in general. In fact, similar to the situation in global homotopy theory [34, Section 6], there is a precise sense in which derived bordism is the localization of bordism at the inverse Thom maps.

A remarkable result of Wasserman implies that bordism is in fact a particular instance of derived bordism with tangential structure. Specifically,  $\Omega_*$  is bordism of derived orbifolds together with a vector bundle  $V$  and a stable isomorphism of vector bundles  $TD - E = V - \underline{\mathbb{R}}^k$ , modulo  $(V, k) \mapsto (V \oplus \underline{\mathbb{R}}, k + 1)$ . This fact fundamentally underlies the Pontryagin–Thom isomorphism for  $\Omega_*$  — homotopical cobordism theories are really all derived cobordism theories with some sort of tangential structure.

We can also consider bordism of orbifolds with tangential structure. The sort of tangential structure  $\mathfrak{S}$  permitted (“coarsely stable” or “stable”) depends on whether we are considering  $\Omega_*^{\mathfrak{S}}$  or  $\Omega_*^{\mathfrak{S}, \text{der}}$ . We leave a precise discussion of these theories for the main body of the paper.

Geometric bordism theories may be extended to the category of orbispectra (to be discussed shortly) by twisting. Structured derived bordism of  $(X, A)^{-\xi}$  is defined as bordism of derived orbifolds over  $(X, A)$  with the given structure on their tangent bundle minus  $\xi$ ; so to extend underived bordism to orbispectra, the key is to think of it as structured derived bordism via Wasserman. For example,  $\Omega_0^{\text{fr}}((X, A)^{-\xi})$  is bordism of derived orbifolds representable over  $(X, A)$  with a stable isomorphism between their tangent bundle and  $\xi$ . Such twistings are the natural home for the fundamental class: given a compact orbifold with boundary  $X$ , it has a fundamental class  $[X] \in \Omega_0^{\text{fr}}((X, \partial X)^{-TX})$ ; orienting  $TX$  with respect to some structure allows one to undo the twist after pushing forward to the corresponding structured bordism group.

### 1.3 Homotopical cobordism theories

Any global spectrum [34] defines a cohomology theory for orbispaces, namely a sequence of functors

$$(1-8) \quad Z^i : \text{OrbSpc}_* \rightarrow \text{Ab}$$

satisfying  $Z^i(\Sigma X) = Z^{i+1}(X)$  and  $Z^i(\bigsqcup_{\alpha} X_{\alpha}) \xrightarrow{\sim} \prod_{\alpha} Z^i(X_{\alpha})$  and which sends cofiber sequences to exact sequences. Namely, given an orthogonal spectrum  $Z : \mathbb{O} \rightarrow \text{Top}_*$ , the group  $Z^0(X, A)$  is the direct limit over vector bundles  $E/X$  of sections of

$\Omega^E Z(E) \rightarrow X$  supported away from  $A$ , modulo homotopy. In fact, we may define  $Z^0((X, A)^{-\xi})$  to be the direct limit of sections of  $\Omega^E Z(E \oplus \xi)$ , which extends  $Z^*$  to the category of orbispectra (which we will meet shortly). The viability of this definition depends on enough vector bundles (though one could formulate a more complicated definition, involving patching together choices of local vector bundles, which would not require an appeal to enough vector bundles). We expect, but do not prove, that this definition is equivalent to that obtained from the composition  $\text{OrbSpc} \hookrightarrow \overline{\text{OrbSpc}} = \text{PSh}(\{\mathbf{BG}\}) = \text{GloSpc} \xrightarrow{\Sigma^\infty} \text{GloSp}$ .

The orthogonal spectra relevant for this paper are the global Thom spectra defined by Schwede [34, Section 6]. These include the global sphere spectrum  $\mathbf{S}$  and the two flavors of the Thom spectrum of the infinite orthogonal group,  $\mathbf{mO}$  and  $\mathbf{MO}$ . The associated cohomology theories are called homotopical cobordism theories.

### 1.4 Categories of orbispectra

To relate geometric bordism and homotopical cobordism requires introducing the category of *orbispectra*. We will only ever discuss *finite* orbispectra, namely desuspensions of finite orbi-CW-pairs by vector bundles. The category of “naive orbispectra” has objects of the form  $\Sigma^{-n}(X, A)$ , with morphisms  $\Sigma^{-n}(X, A) \rightarrow \Sigma^{-m}(Y, B)$  given by the direct limit over  $k$  of the space of relative morphisms  $\Sigma^{k-n}(X, A) \rightarrow \Sigma^{k-m}(Y, B)$ . We are more interested in the category of “genuine orbispectra”, whose objects take the form  $(X, A)^{-V}$  for  $V$  a vector bundle (with possibly nontrivial isotropy representations) and whose morphisms are defined by a direct limit over passing to Thom spaces of arbitrary vector bundles.

We define two homotopy categories of finite (genuine) orbispectra  $\text{RepOrbSp}^f$  and  $\text{OrbSp}^f$ , again depending on whether we use representable maps or not. They fit into a diagram

$$(1-9) \quad \text{Sp}^f \rightarrow \text{RepOrbSp}^f \rightarrow \text{OrbSp}^f,$$

with  $\text{Sp}^f$  (the category of finite spectra) being a full subcategory of the latter two. The definitions of these categories use enough vector bundles (though this could probably be eliminated if one took a more abstract approach).

The categories  $\text{Sp}^f$  and  $\text{RepOrbSp}^f$  are natural settings for stable homotopy theory. For example, every morphism in  $\text{RepOrbSp}^f$  fits into an “exact triangle” (although we do not actually prove that  $\text{RepOrbSp}^f$  is triangulated). We conjecture that the category

$\text{RepOrbSp}$ —a category we do not define, but at the level of  $\infty$ -categories it would be  $\text{Ind RepOrbSp}^f$ —is the category of parametrized spectra over  $R(*)$ .

As before,  $\text{OrbSp}^f$  does not seem to be natural setting for stable homotopy theory. It seems likely there is a functor  $\text{OrbSp}^f \rightarrow \text{GloSp}$  (the category of global spectra [34]), though we do not quite construct it, nor is it clear if we should expect it to be fully faithful.

## 1.5 Duality

Now a key result is to define a contravariant involution  $D$  (“duality”) on the category  $\text{RepOrbSp}^f$ . The construction of this functor relies crucially on enough vector bundles.

**Theorem 1.3** *The category  $\text{RepOrbSp}^f$  admits a contravariant involution  $D$  preserving cofiber sequences, defined by declaring that*

- (1) *for any compact orbifold with boundary  $X$  and codimension-zero suborbifold with boundary  $A \subseteq \partial X$ , we have*

$$(1-10) \quad D((X, A)^{-\xi}) = (X, \partial X - A^\circ)^{\xi - TX},$$

and

- (2) *for any smooth embedding of such pairs  $f: (X, A) \hookrightarrow (Y, B)$  (so  $X \subseteq Y$  is a smooth suborbifold of  $Y$  meeting  $\partial Y$  transversely precisely in  $A = X \cap B$ ), we have that  $(Df)^{TY}: (Y, \partial Y - B^\circ) \rightarrow (X, \partial X - A^\circ)^{TY/TX}$  is the obvious collapse map.*

It follows from the definition that  $D$  stabilizes the full subcategory  $\text{Sp}^f \subseteq \text{RepOrbSp}^f$  and coincides on it with classical Spanier–Whitehead duality of finite spectra [36]; the definition of  $D$  is essentially identical to Atiyah’s formulation [3], just generalized to orbifolds. However, whereas Spanier–Whitehead duality on  $\text{Sp}^f$  is characterized by the universal property of a map  $X \wedge Y \rightarrow S^0$  being the same as a map  $X \rightarrow DY$ , we do not know a universal-property characterization of the involution  $D$  on  $\text{RepOrbSp}^f$ . There is at least a natural map from maps  $X \rightarrow Y$  to maps  $X \wedge DY \rightarrow R(*)$ , but it is not an isomorphism and we do not know any sense in which it characterizes  $D$ ; the essential reason for this is that  $\wedge$  does not play well with representability; see Example 1.8. The identity map  $X \rightarrow X$  thus corresponds to a canonical pairing  $X \wedge DX \rightarrow R(*)$  which,

upon passing to classifying spaces (note that  $\widetilde{R}(\ast) = \ast$ ), gives a pairing  $\widetilde{X} \wedge \widetilde{DX} \rightarrow S^0$ , hence a comparison map

$$(1-11) \quad \widetilde{DX} \rightarrow D\widetilde{X},$$

where we should understand that the classifying space of an object of  $\text{RepOrbSp}^f$  is an object of  $\text{Sp} = \text{Ind Sp}^f$ , not  $\text{Sp}^f$ , so  $D\widetilde{X}$  is an object of  $\text{Pro Sp}^f$ . The results of Greenlees and Sadofsky [19, Corollary 1.2] and Cheng [9] may be viewed as the assertion that this comparison map is  $K(n)$ -local for all  $n$ , where  $K(n)$  denotes Morava  $K$ -theory.

Duality allows us to define, for any global spectrum  $E$ , an  $E$ -homology functor  $\text{RepOrbSp}^f \rightarrow \text{Ab}$  by taking

$$(1-12) \quad E_*(X) := E^{-*}(DX).$$

Note that whereas  $E$ -cohomology is a functor on  $\text{OrbSp}^f$ , we only define  $E$ -homology as a functor on  $\text{RepOrbSp}^f$ .

Recall that in ordinary stable homotopy theory, the  $E$ -homology of a (finite) space  $X$  is defined as  $[S^0, X \wedge E] = [DX, E]$ . Due to  $D$  not being the monoidal dual with respect to  $\wedge$ , this equality no longer holds in our context, so there are a priori two reasonable notions of  $E$ -homology for orbispaces. We consider the latter definition since it is the one which is relevant for the Pontryagin–Thom isomorphism. The former definition (implemented in the context of global homotopy theory) is proposed by Schwede [34] and is presumably quite different.

### 1.6 Pontryagin–Thom isomorphism

We may now state the Pontryagin–Thom isomorphism relating geometric bordism and homotopical cobordism on  $\text{RepOrbSp}^f$ .

**Theorem 1.4** *There are natural isomorphisms of functors on  $\text{RepOrbSp}^f$*

$$(1-13) \quad \mathbf{S}_* = \Omega_*^{\text{fr}},$$

$$(1-14) \quad \mathbf{mO}_* = \Omega_*,$$

$$(1-15) \quad \mathbf{MO}_* = \Omega_*^{\text{der}}.$$

**Example 1.5** Under the Pontryagin–Thom isomorphism, the unit  $\mathbf{1} \in \mathbf{S}^0(X)$  is sent to the fundamental class  $[X] \in \Omega_0^{\text{fr}}((X, \partial X)^{-TX})$  for any compact orbifold-with-boundary  $X$ .

**Example 1.6** The orbi-CW-complex  $R(*)$  is not finite, but we may nevertheless define  $\Omega_*(R(*))$  and  $\mathbf{mO}_*(R(*))$  by taking the direct limit over finite subcomplexes, and we conclude they are isomorphic; compare Example 1.1.

The Pontryagin–Thom construction also gives a description of the morphism groups in  $\text{RepOrbSp}^f$  and in  $\text{OrbSp}^f$  in terms of bordism.

**Theorem 1.7** *Let  $(X, A)$  and  $(Y, B)$  be compact orbi-CW-pairs carrying stable vector bundles  $\xi$  and  $\zeta$ . The set of morphisms*

$$(1-16) \quad D((X, A)^{-\xi}) \rightarrow (Y, B)^{-\zeta}$$

*in  $\text{OrbSp}^f$  (resp.  $\text{RepOrbSp}^f$ ) is in canonical bijection with bordism classes of derived orbifolds  $(C, \partial C)$  with a representable map  $f: C \rightarrow X$ , a map (resp. representable map)  $g: C \rightarrow Y$  such that  $\partial C \subseteq f^{-1}(A) \cup g^{-1}(B)$ , and a stable isomorphism between  $TC$  and  $f^*\xi + g^*\zeta$ .*

Note that this result gives multiple descriptions of the same stable mapping group, since a given object of  $\text{OrbSp}^f$  or  $\text{RepOrbSp}^f$  may be expressed as  $(X, A)^{-\xi}$  in many different ways; in particular, passing from  $(X, A)^{-\xi}$  to  $((X, A)^V)^{-V-\xi}$  via the obvious isomorphism acts via Theorem 1.7 on bordism classes of derived orbifolds by passing to the Thom space of the pullback of  $V$  (and similarly for  $(Y, B)^{-\zeta}$ ). Also note that, in the case of  $\text{RepOrbSp}^f$ , the description of morphisms is manifestly symmetric in  $(X, A)^{-\xi}$  and  $(Y, B)^{-\zeta}$ , as it should be given that  $D$  is an involution.

**Example 1.8** As we remarked earlier, there is a canonical pairing  $W \wedge DW \rightarrow R(*)$  in  $\text{RepOrbSp}^f$ , which induces a natural transformation

$$(1-17) \quad \text{Hom}(Z, W) \rightarrow \text{Hom}(Z \wedge DW, R(*)).$$

Let us understand it via Theorem 1.7. Set  $Z = D((X, A)^{-\xi})$  and  $W = (Y, B)^{-\zeta}$ . The domain of (1-17) consists of bordism classes of derived orbifolds  $(C, \partial C)$  with representable maps  $f: C \rightarrow X$  and  $g: C \rightarrow Y$  such that  $\partial C \subseteq f^{-1}(A) \cup g^{-1}(B)$ , together with a stable isomorphism between  $TC$  and  $f^*\xi + g^*\zeta$ . The codomain consists of bordism classes of derived orbifolds  $(C, \partial C)$  with a representable map  $(C, \partial C) \rightarrow (X, A) \times (Y, B)$  and an isomorphism between  $TC$  and the pullback of  $\xi + \zeta$  — note that there is a unique up to homotopy representable map  $C \rightarrow R(*)$ , so we can simply ignore this piece of data. The map from the domain to the codomain is the evident one: send  $(f, g)$  to  $f \times g$ . Of course, representability of  $f \times g$  is a rather different (and weaker) condition from representability of both  $f$  and  $g$ .



A notable omission in Theorem 1.7 is an interpretation of the bordism group where both  $f$  and  $g$  are arbitrary (not necessarily representable).

**Acknowledgements** We thank André Henriques for discussions about orbispaces and Stefan Schwede for discussions about global homotopy theory. The comments from both referees were also extremely helpful. This research was conducted during the period the author served as a Clay Research Fellow and was partially supported by a Packard Fellowship and by the National Science Foundation under the Alan T Waterman Award, grant 1747553.

## 2 Topology of orbispaces

### 2.1 Orbispaces as topological stacks

We briefly recall some definitions and basic properties; for further background we refer the reader to [29, Section 3; 20; 27; 4; 25; 5].

We work in the 2–category  $\text{Shv}(\text{Top}, \text{Grpd})$ , whose objects will simply be called “stacks”. Morphisms between stacks do not form a set, rather a groupoid, which is the meaning of the prefix “2–”.

The Yoneda inclusion  $\text{Top} \hookrightarrow \text{Shv}(\text{Top}, \text{Grpd})$  is continuous, and we systematically identify objects of  $\text{Top}$  with their images in  $\text{Shv}(\text{Top}, \text{Grpd})$ . Such stacks are called *representable*.

A morphism of stacks  $X \rightarrow Y$  is called representable if and only if for every topological space  $Z$  and every map  $Z \rightarrow Y$ , the fiber product  $X \times_Y Z$  is representable. For any property  $\mathcal{P}$  of morphisms of topological spaces which is preserved under pullback, a representable map of stacks  $X \rightarrow Y$  is said to have  $\mathcal{P}$  if and only if  $X \times_Y Z \rightarrow Z$  has  $\mathcal{P}$  for every topological space  $Z$  and every map  $Z \rightarrow Y$ . Examples of such properties include being an open inclusion, a closed inclusion, étale, separated, proper (which by definition implies separated), and admitting local sections.

The inclusion  $\text{Top} \subseteq \text{Shv}(\text{Top}, \text{Grpd})$  admits a left adjoint  $|\cdot| : \text{Shv}(\text{Top}, \text{Grpd}) \rightarrow \text{Top}$  known as passing to the *coarse space* of a stack. For a fixed stack  $X$ , open (resp. closed) inclusions  $Y \hookrightarrow X$  are in bijection with open (resp. closed) subsets  $|Y| \subseteq |X|$ .

A stack  $X$  is called *topological* if and only if there exists a representable map admitting local sections  $U \rightarrow X$  from a topological space  $U$ ; such a map is called an *atlas*.

A choice of atlas  $U \rightarrow X$  gives rise to a topological groupoid  $U \times_X U \rightrightarrows U$  presenting  $X$ . Conversely, every topological groupoid  $M \rightrightarrows O$  is uniquely of this form. The coarse space of a topological stack  $X$  is the quotient of any atlas  $U$  by the image of  $U \times_X U \rightarrow U \times U$  (which is an equivalence relation). For a topological group  $G$  acting continuously on a topological space  $V$ , the stack quotient  $V/G$  is by definition the topological stack presented by the action groupoid  $G \times V \rightrightarrows V$ .

By a “point”  $p$  of a stack  $X$ , we mean a map  $p: * \rightarrow X$ , ie an object of  $X(*)$ , where  $*$  denotes the one point space. The automorphism group of this object of  $X(*)$  is called the *isotropy group* of  $p$ , denoted by  $G_p$ . Given a point  $* \rightarrow X$ , the fiber product  $* \times_X *$  has trivial isotropy, and its points are in bijection with  $G_p$ . If  $X$  is a topological stack, then  $* \times_X *$  is a topological space, which thus endows  $G_p$  with the structure of a topological group.

A *separated orbispace* is a stack  $X$  which admits an étale atlas  $U \rightarrow X$  and whose diagonal  $X \rightarrow X \times X$  is proper. Equivalently,  $X$  is a separated orbispace if and only if  $|X|$  is Hausdorff and there exists a cover of  $X$  by open substacks of the form  $Y/\Gamma$  where  $\Gamma$  is a finite discrete group acting continuously on a Hausdorff topological space  $Y$  [29, Proposition 3.3]. In particular, a separated orbispace has an étale atlas  $U \rightarrow X$  for which  $U$  is Hausdorff. Henceforth we will drop the prefix “separated” from “separated orbispace” and simply write “orbispace”.

The isotropy groups of an orbispace are all finite and discrete. A map of orbispaces is representable if and only if it is injective on isotropy groups [29, Corollary 3.6]; in particular, an orbispace is a space if and only if its isotropy groups are all trivial.

The stack quotient  $V/G$  is an orbispace provided  $V$  is Hausdorff,  $G$  is compact Hausdorff (these imply  $V/G$  has proper diagonal), and there exists a map  $W \rightarrow V$  such that the resulting map  $G \times W \rightarrow V$  is étale (this implies that  $W \rightarrow V/G$  is an étale atlas). In particular,  $V/G$  is an orbispace for  $V$  Hausdorff and  $G$  finite.

An orbispace is called *paracompact* if and only if its coarse space is paracompact.

For any finite group  $G$  (we equip all finite groups with the discrete topology), the stack  $\mathbf{B}G := */G$  (the stack quotient of a point  $*$  by the trivial action of  $G$ ) is an orbispace. The quotient map  $* \rightarrow \mathbf{B}G$  is the universal principal  $G$ -bundle: for any stack  $Y$ , the functor from maps  $Y \rightarrow \mathbf{B}G$  to principal  $G$ -bundles over  $Y$  given by pulling back  $* \rightarrow \mathbf{B}G$  is an equivalence of groupoids. The groupoid of maps  $\mathbf{B}G \rightarrow \mathbf{B}H$  is (canonically equivalent to) the groupoid  $\text{Hom}(G, H)/H$  in which an object is a group

homomorphism  $\varphi: G \rightarrow H$  and in which an isomorphism  $\varphi \xrightarrow{\sim} \varphi'$  is an element  $h \in H$  satisfying  $\varphi = h\varphi'h^{-1}$ . The full subcategory of stacks of the form  $\mathbf{B}G$  for some finite group  $G$  is thus equivalent to the 2–category  $\mathbf{FinGrp}$  of finite groups, homomorphisms, and conjugations. We will frequently restrict consideration to representable maps, in which case the category formed by  $\mathbf{B}G$  is denoted by  $\mathbf{InjFinGrp}$ , which is the same as  $\mathbf{FinGrp}$  except homomorphisms are required to be injective.

**Lemma 2.1** *For orbispaces  $X$  and  $Y$ , the product  $X \times Y$  is an orbispace and the natural map  $|X \times Y| \rightarrow |X| \times |Y|$  is a homeomorphism.*

**Proof** For étale atlases  $U_X \rightarrow X$  and  $U_Y \rightarrow Y$ , the product  $U_X \times U_Y \rightarrow X \times Y$  is an étale atlas, and the diagonal of  $X \times Y$  is the product of the diagonals of  $X$  and  $Y$ , hence is proper. Thus  $X \times Y$  is an orbispace.

The assertion that  $|X \times Y| \rightarrow |X| \times |Y|$  is a homeomorphism can be checked locally on  $|X|$  and  $|Y|$ . It thus suffices to show that for actions of finite groups  $G$  and  $H$  on Hausdorff spaces  $X$  and  $Y$ , the natural map  $|(X \times Y)/(G \times H)| \rightarrow |X/G| \times |Y/H|$  is a homeomorphism. This map is obviously a bijection. Open subsets of the domain correspond to  $(G \times H)$ –invariant open subsets of  $X \times Y$ . Open subsets of the target are generated by products of  $G$ –invariant open subsets of  $X$  with  $H$ –invariant open subsets of  $Y$ . Open subsets of the latter form are certainly of the former form (which is the obvious direction in which  $|X \times Y| \rightarrow |X| \times |Y|$  is continuous). Conversely, suppose  $U \subseteq X \times Y$  is a  $(G \times H)$ –invariant open set and let  $(x, y) \in U$ . Let us show that there exists a product of a  $G$ –invariant open subset of  $X$  and an  $H$ –invariant open subset of  $Y$  which contains  $(x, y)$  and is contained in  $U$ . Since  $U$  is open in the product topology, it contains a neighborhood  $V \times W$  of  $(x, y)$  where  $V \subseteq X$  and  $W \subseteq Y$  are open. Now since  $U$  is  $(G \times H)$ –invariant, it also contains  $(G \cdot V) \times (H \cdot W)$ , so we are done. □

**Lemma 2.2** *If  $X$  is an orbispace and  $U \rightarrow X$  is an étale atlas with  $U$  Hausdorff, then  $U \rightarrow X$  is separated.*

**Proof** The map  $U \times_X U \rightarrow U \times U$  is separated since  $X \rightarrow X \times X$  is separated, and the map  $U \times U \rightarrow U$  is separated since  $U$  is Hausdorff. The composition  $U \times_X U \rightarrow U$  is thus separated; hence  $U \rightarrow X$  is separated. □

**Lemma 2.3** *A map of orbispaces is an isomorphism if and only if it induces isomorphisms on isotropy groups and induces a homeomorphism on coarse spaces.*

**Proof** Let  $f: X \rightarrow Y$  be a map of orbispaces which induces isomorphisms on isotropy groups  $G_x \xrightarrow{\sim} G_{f(x)}$  and induces a homeomorphism on coarse spaces  $|f|: |X| \rightarrow |Y|$ , and let us show that  $f$  is an isomorphism. The property of  $f$  being an isomorphism is local on  $|Y|$ , so we may assume without loss of generality that  $Y = Y'/G$  for some finite group  $G$  acting continuously on a Hausdorff space  $Y'$ . Since  $f$  is representable,  $X' := Y' \times_Y X$  is a space, and  $X = X'/G$ . We thus have a  $G$ -equivariant map  $X' \rightarrow Y'$ , which induces a homeomorphism  $|X'/G| \xrightarrow{\sim} |Y'/G|$  and which induces isomorphisms on stabilizer groups. This implies that  $X' \rightarrow Y'$  is a bijection. It suffices to show that the map  $f': X' \rightarrow Y'$  is open, and hence is a homeomorphism. What we know is that  $f'$  sends  $G$ -invariant open subsets to open subsets. Let  $x \in X'$ . Since  $Y'$  is Hausdorff, there exist open neighborhoods  $U_g \subseteq Y'$  of  $g \cdot f'(x)$  for all  $g \in G$  such that  $g \cdot U_h = U_{gh}$  and  $U_g \cap U_h = \emptyset$  for  $g \cdot f'(x) \neq h \cdot f'(x)$  while  $U_g = U_h$  for  $g \cdot f'(x) = h \cdot f'(x)$ . Now let  $V \subseteq (f')^{-1}(U_1)$  be any open neighborhood of  $x$ . Its image  $f'(V) \subseteq Y$  is the intersection of two open sets  $f'(G \cdot V) \cap U_1$ , so  $f'(V)$  is open. Thus  $f'$  is open.  $\square$

A *topological orbifold* is an orbispace  $X$  which is étale locally homeomorphic to  $\mathbb{R}^n$ , in the sense that for some (equivalently, every) étale atlas  $U \rightarrow X$ , the space  $U$  is locally homeomorphic to  $\mathbb{R}^n$  (it may also be required paracompact if one so desires). In other words,  $X$  is locally isomorphic to  $U/\Gamma$  for  $U \subseteq \mathbb{R}^n$  open and  $\Gamma \curvearrowright U$  acting continuously. A topological orbifold is called *locally tame* if and only if we may take such actions  $\Gamma \curvearrowright U$  to be restrictions of linear actions on  $\mathbb{R}^n$ . A smooth structure on a topological orbifold  $X$  is a choice of atlas  $U \rightarrow X$  together with a smooth structure on  $U$  such that the two smooth structures on  $U \times_X U$  obtained via pullback from the smooth structure on  $U$  coincide (smooth structures relative to  $U \rightarrow X$  and  $U' \rightarrow X$  are equivalent if and only if they give rise to the same pullback smooth structure on  $U \times_X U'$ ). Smooth orbifolds are locally isomorphic to  $U/\Gamma$  for  $U \subseteq \mathbb{R}^n$  open and  $\Gamma \curvearrowright U$  acting smoothly (equivalently, linearly).

## 2.2 Vector bundles and principal bundles over orbispaces

A (real) vector bundle over a stack  $X$  is a representable map  $V \rightarrow X$  along with maps  $\mathbb{R} \times V \rightarrow V$  and  $V \times_X V \rightarrow V$  over  $X$  such that the pullback to any topological space  $Z \rightarrow X$  is a vector bundle over  $Z$  with its fiberwise scaling and addition maps. Similarly, for a Lie group  $G$ , a principal  $G$ -bundle over a stack  $X$  is a representable map  $P \rightarrow X$  along with a map  $G \times P \rightarrow P$  over  $X$  such that the pullback to any

topological space  $Z \rightarrow X$  is a principal  $G$ -bundle with its  $G$ -action. We only ever consider finite-dimensional vector bundles, so we will usually omit the adjective “finite-dimensional” for the sake of brevity. We will also only ever consider positive definite inner products, so we will also usually omit the adjective “positive definite”.

For a vector bundle  $V \rightarrow X$  and a point  $p: * \rightarrow X$ , the fiber  $V_p := V \times_X *$  carries a linear action of the isotropy group  $G_p$ . Similarly, given a principal  $G$ -bundle  $P \rightarrow X$  and a point  $p: * \rightarrow X$ , the fiber  $P_p$  carries a  $G_p$ -action compatible with the  $G$ -action; so, fixing an identification of  $G$ -spaces  $P_p = G$ , this becomes a homomorphism  $G_p \rightarrow G$ .

**Lemma 2.4** *For any topological space  $X$ , the tautological bijection between (setwise) maps  $X \times \mathbb{R}^n \rightarrow \mathbb{R}^m$  (resp.  $X \times G \rightarrow G$ ) which for every fixed  $x \in X$  are linear (resp.  $G$ -equivariant) and maps  $X \rightarrow \text{Hom}(\mathbb{R}^n, \mathbb{R}^m)$  (resp.  $X \rightarrow G$ ) restricts to a bijection between the subsets of continuous maps.*

**Proof** For one direction, the map  $\mathbb{R}^n \times \text{Hom}(\mathbb{R}^n, \mathbb{R}^m) \rightarrow \mathbb{R}^m$  (resp.  $G \times G \rightarrow G$ ) is continuous, so its pullback along a continuous map  $X \rightarrow \text{Hom}(\mathbb{R}^n, \mathbb{R}^m)$  (resp.  $X \rightarrow G$ ) remains continuous. For the other direction, note that the “matrix entries” of a map  $X \rightarrow \text{Hom}(\mathbb{R}^n, \mathbb{R}^m)$  can be recovered from the map  $X \times \mathbb{R}^n \rightarrow X \times \mathbb{R}^m$  by appropriate pre- and post-composition with maps  $* \rightarrow \mathbb{R}^n$  and  $\mathbb{R}^m \rightarrow \mathbb{R}$ , and similarly for Lie groups  $G$ . □

It follows immediately from Lemma 2.4 that for any topological space  $X$ , the functor from the groupoid of maps  $X \rightarrow \bigsqcup_{n \geq 0} */\text{GL}_n(\mathbb{R})$  to vector bundles over  $X$  defined by pulling back the vector bundle  $\bigsqcup_{n \geq 0} \mathbb{R}^n/\text{GL}_n(\mathbb{R}) \rightarrow \bigsqcup_{n \geq 0} */\text{GL}_n(\mathbb{R})$  is an equivalence; similarly for  $X \rightarrow */G$  and principal  $G$ -bundles, and similarly for  $X \rightarrow \bigsqcup_{n \geq 0} */O(n)$  and vector bundles with inner product. These statements automatically extend to arbitrary stacks  $X$ : a vector bundle  $V \rightarrow X$  is the same as the specification, compatible with pullback, of a vector bundle  $V_Z \rightarrow Z$  for every map  $Z \rightarrow X$  from a topological space  $Z$ , which is, by the above result for topological spaces, the same as the specification, compatible with pullback, of a map  $Z \rightarrow */\text{GL}_n(\mathbb{R})$  for every map  $Z \rightarrow X$  from a topological space  $Z$ , which is the same as a map of stacks  $X \rightarrow \bigsqcup_{n \geq 0} */\text{GL}_n(\mathbb{R})$  (and similarly for  $*/G$  and  $*/O(n)$ ).

There is a standard deformation retraction from  $\text{Inj}(\mathbb{R}^n, \mathbb{R}^m)$  to the subspace of isometric injections given by  $f \mapsto f(f^*f)^{-t/2}$  for  $t \in [0, 1]$ . Since this deformation retraction is  $O(n) \times O(m)$ -equivariant, by Lemma 2.4 it induces, for any injective map of vector

bundles with inner products over a topological space  $X$ , a canonical homotopy through injections to an isometric injection; moreover, the same holds for arbitrary stacks  $X$ , by the reasoning as in the previous paragraph.

We now move on to some foundational results which are specific to orbispaces.

**Lemma 2.5** *Every principal  $G$ -bundle over an orbispace  $X$  is locally of the form  $(G \times Y)/\Gamma \rightarrow Y/\Gamma$  for  $\Gamma \curvearrowright Y$  and  $\Gamma \rightarrow G$ .*

**Proof** The case of  $G = GL_n(\mathbb{R})$  (ie vector bundles) was proven in [29, Lemma 6.7]. The essential point in generalizing the proof given there to general  $G$  is to note that there is a  $G$ -conjugation,  $G$ -translation and  $S_n$ -invariant “averaging” operation giving a retraction onto the diagonal  $G \subseteq G^n$  defined in its neighborhood.  $\square$

Some important properties of vector bundles and principal bundles require a paracompactness assumption.

**Lemma 2.6** [29, Lemma 5.1] *Every vector bundle over a paracompact orbispace has an inner product.*  $\square$

**Lemma 2.7** *For a paracompact orbispace  $X$ , every principal  $G$ -bundle over  $X \times [0, 1]$  is pulled back from  $X$ .*

**Proof** The case of  $G = GL_n(\mathbb{R})$  (ie vector bundles) was proven in [29, Lemma 6.2]. The same averaging operation as before allows this proof to apply to general  $G$ .  $\square$

### 2.3 Gluing orbispaces

We now explain how some basic topological gluing constructions are generalized to the orbispace context. These constructions provide the foundation for doing algebraic topology with orbispaces.

We begin with a discussion of how to glue together stacks along open substacks. The first step is to observe the following “descent for morphisms” property:

**Lemma 2.8** *Let  $X = \bigcup_{\alpha} U_{\alpha}$  be a cover by open substacks. The functor*

$$(2-1) \quad \text{Hom}(X, Y) \xrightarrow{\sim} \left\{ f_{\alpha} \in \text{Hom}(U_{\alpha}, Y), g_{\alpha\beta}: f_{\alpha}|_{U_{\alpha} \cap U_{\beta}} \xrightarrow{\sim} f_{\beta}|_{U_{\alpha} \cap U_{\beta}} \mid \right. \\ \left. g_{\alpha\beta} g_{\beta\gamma} = g_{\alpha\gamma} \text{ over } U_{\alpha} \cap U_{\beta} \cap U_{\gamma} \right\}$$

*is an equivalence for any stack  $Y$ . (On the right side, an isomorphism  $(f_{\alpha}, g_{\alpha\beta}) \rightarrow (f'_{\alpha}, g'_{\alpha\beta})$  consists of  $\pi_{\alpha}: f_{\alpha} \xrightarrow{\sim} f'_{\alpha}$  such that  $g'_{\alpha\beta} \pi_{\beta} = \pi_{\alpha} g_{\alpha\beta}$  over  $U_{\alpha} \cap U_{\beta}$ .)*

**Proof** We may construct an inverse to (2-1) as follows. Given an element of the right-hand side, we may associate to any map  $Z \rightarrow X$  (where  $Z$  is a topological space) a map  $Z \rightarrow Y$ , as follows. The map  $Z \rightarrow X$  induces an open cover  $Z = \bigcup_{\alpha} Z \times_X U_{\alpha}$ . Each map  $Z \times_X U_{\alpha} \rightarrow U_{\alpha}$  may be composed with our chosen element on the right side of (2-1) to a map  $Z \times_X U_{\alpha} \rightarrow Y$ . The compatibility data on the right side of (2-1) provides descent data to glue these maps together (using the stack property for  $Y$ ) to a map  $Z \rightarrow Y$ . We have thus associated to each map  $Z \rightarrow X$  a map  $Z \rightarrow Y$ . This construction is compatible with pullback, hence defines a map of stacks  $X \rightarrow Y$ . Tracing through definitions, it can be checked that this map is a two-sided inverse to (2-1).  $\square$

Lemma 2.8 may be reformulated as saying that  $X$  is the colimit of the diagram consisting of the open substacks  $U_{\alpha}$ , their pairwise intersections  $U_{\alpha} \cap U_{\beta}$ , and their triple intersections  $U_{\alpha} \cap U_{\beta} \cap U_{\gamma}$  (and no higher intersections).

Going in the opposite direction, let us argue that pushouts of open inclusions of stacks always exist. Namely, consider a pair of open inclusions  $X \hookrightarrow U \hookrightarrow Y$ . Given such data, we may define a stack  $X \cup_U Y$  by the following natural mapping property: a map  $Z \rightarrow X \cup_U Y$  (with  $Z$  a topological space) consists of an open cover  $Z = Z_X \cup Z_Y$ , maps  $Z_X \rightarrow X$  and  $Z_Y \rightarrow Y$  such that in both cases the inverse image of  $U$  is  $Z_X \cap Z_Y$ , together with an isomorphism between the two resulting maps  $Z_X \cap Z_Y \rightarrow U$ . It is immediate to check that the maps  $X \rightarrow X \cup_U Y \leftarrow Y$  are both open inclusions intersecting along  $U$ , so Lemma 2.8 implies that

$$(2-2) \quad \begin{array}{ccc} U & \longrightarrow & X \\ \downarrow & & \downarrow \\ Y & \longrightarrow & X \cup_U Y \end{array}$$

is a pushout. Since  $X \hookrightarrow X \cup_U Y \leftarrow Y$  are open inclusions, it follows that if  $X$  and  $Y$  both admit étale atlases, then so do  $U$  and  $X \cup_U Y$ . Also, if  $X$  and  $Y$  are locally of the form  $V/\Gamma$  for a finite group  $\Gamma$  acting on a Hausdorff space  $V$ , then the same holds for  $X \cup_U Y$ . Thus if  $X$  and  $Y$  are orbispaces, to verify that  $X \cup_U Y$  is an orbispace, it suffices to show that  $|X \cup_U Y|$  is Hausdorff. Since the coarse space functor  $|\cdot|$  is a left adjoint, it preserves all colimits, so  $|X \cup_U Y| = |X| \cup_{|U|} |Y|$ . This gives an effective procedure to glue together a pair of orbispaces along a common open subspace and to show that the result is again an orbispace.

The next construction we wish to discuss is the formation of mapping cylinders for representable maps of orbispaces. For a map of topological spaces  $A \rightarrow X$ , the mapping

cylinder  $\text{cyl}(A \rightarrow X)$  is defined as the pushout

$$(2-3) \quad \begin{array}{ccc} A & \longrightarrow & X \\ \downarrow \times \{0\} & & \downarrow \\ A \times [0, 1] & \longrightarrow & \text{cyl}(A \rightarrow X) \end{array}$$

A basic property of colimits in the category of topological spaces is that the property of a diagram being a colimit diagram is local on the colimit object. It follows that colimit diagrams are preserved under étale pullback: if  $U \rightarrow \text{colim } p$  is étale, then the natural map  $\text{colim}(p \times_{\text{colim } p} U) \rightarrow U$  is an isomorphism. Thus the formation of mapping cylinders commutes with étale pullback: if  $U \rightarrow X$  is étale, then the natural map  $\text{cyl}(A \times_X U \rightarrow U) \rightarrow \text{cyl}(A \rightarrow X) \times_X U$  is an isomorphism. This fact allows us to define the mapping cylinder of any representable map of stacks  $A \rightarrow X$  for which  $X$  (hence also  $A$ ) admits an étale atlas. Indeed, let  $A \rightarrow X$  be such a map. Choose an étale atlas  $U \rightarrow X$ , which pulls back to an étale atlas  $A \times_X U \rightarrow A$ . We thus obtain a topological groupoid  $U \times_X U \rightrightarrows U$  presenting the stack  $X$ , and we obtain a topological groupoid  $U \times_X A \times_X U \rightrightarrows A \times_X U$  presenting  $A$ . The map  $A \rightarrow X$  induces a map of topological groupoids from the latter to the former, which presents the map  $A \rightarrow X$ . We may consider the “cylinder” of this map of groupoids, namely

$$(2-4) \quad \text{cyl}(U \times_X A \times_X U \rightarrow U \times_X U) \rightrightarrows \text{cyl}(A \times_X U \rightarrow U),$$

and we define  $\text{cyl}(A \rightarrow X)$  to be the topological stack presented by this groupoid. Note that  $\text{cyl}(U \times_X A \times_X U \rightarrow U \times_X U) = \text{cyl}(A \times_X U \rightarrow U) \times_X U$  since  $U \rightarrow X$  is étale.

**Lemma 2.9** *The stack  $\text{cyl}(A \rightarrow X)$  is independent, up to canonical equivalence, of the choice of étale atlas  $U \rightarrow X$ .*

**Proof** It suffices to show that for any two atlases  $U \rightarrow X \leftarrow U'$ , the inclusions of the groupoids (2-4) for  $U$  and  $U'$  into the groupoid for  $U \sqcup U'$  induce equivalences of stacks. To show this, it in turn suffices to show that the map

$$(2-5) \quad \text{cyl}(U' \times_X A \times_X U \rightarrow U' \times_X U) \rightarrow \text{cyl}(A \times_X U \rightarrow U)$$

admits local sections. This in turn is implied by the assertion that the natural map

$$(2-6) \quad \text{cyl}(U' \times_X A \times_X U \rightarrow U' \times_X U) \rightarrow U' \times_X \text{cyl}(A \times_X U \rightarrow U)$$

is an isomorphism, which holds as formation of mapping cylinders of topological spaces commutes with étale pullback (both sides are  $(U' \times_X U) \times_U \text{cyl}(A \times_X U \rightarrow U)$ ).  $\square$



Formation of mapping cylinders commutes with passing to the coarse space: for any representable map of stacks  $A \rightarrow X$  admitting étale atlases, the natural map  $\text{cyl}(|A| \rightarrow |X|) \rightarrow |\text{cyl}(A \rightarrow X)|$  is an isomorphism. This can be checked by inspection, using the fact that for any topological stack  $X$  with atlas  $U \rightarrow X$ , the map  $U \rightarrow |X|$  is the topological quotient by the image of  $U \times_X U \rightarrow U \times U$ , and fact that  $|A \times [0, 1]| \rightarrow |A| \times [0, 1]$  is an isomorphism for any topological stack  $A$  [29, Lemma 6.15].

It now follows that if  $A$  and  $X$  are both orbispaces, then so is  $\text{cyl}(A \rightarrow X)$ . Indeed, if  $Y/\Gamma \hookrightarrow X$  is an open inclusion for  $Y$  Hausdorff and  $\Gamma$  finite, we obtain an open inclusion  $(A \times_X Y)/\Gamma = A \times_X (Y/\Gamma) \hookrightarrow A$ . Since  $A$  is an orbispace, its diagonal is proper, so the action map  $\Gamma \times (A \times_X Y) \rightarrow (A \times_X Y) \times (A \times_X Y)$  is proper, hence its precomposition with  $A \times_X Y \xrightarrow{1 \times} \Gamma \times (A \times_X Y)$  is proper; this being the diagonal of  $A \times_X Y$ , we conclude that  $A \times_X Y$  is Hausdorff. We thus have an open inclusion  $\text{cyl}(A \times_X Y \rightarrow Y)/\Gamma \hookrightarrow \text{cyl}(A \rightarrow X)$ , where  $\text{cyl}(A \times_X Y \rightarrow Y)$  is Hausdorff. The coarse space  $|\text{cyl}(A \rightarrow X)| = \text{cyl}(|A| \rightarrow |X|)$  is Hausdorff since  $|X|$  and  $|A|$  are.

Our next task is to show that the mapping cylinder diagram (2-3) is a pushout. This gives another proof of the fact that formation of mapping cylinders commutes with passing to the coarse space. We begin with an example to show that mapping cylinder diagrams, even of topological spaces, need not be pushouts in the category of *all* stacks. Our task is thus, more precisely, to identify a particular full subcategory of stacks in which mapping cylinder diagrams are pushouts; see Proposition 2.13 below.

**Example 2.10** Consider the pushout diagram

$$(2-7) \quad \begin{array}{ccc} \{1\} & \longrightarrow & [1, 2] \\ \downarrow & & \downarrow \\ [0, 1] & \longrightarrow & [0, 2] \end{array}$$

in the category of topological spaces. Let  $X$  denote the stack defined by the property that a map  $Z \rightarrow X$  from a topological space  $Z$  is a continuous map  $f: Z \rightarrow [0, 2]$  such that there exists an open cover  $Z = U \cup V$  with  $f(U) \subseteq [0, 1]$  and  $f(V) \subseteq [1, 2]$ . (Note that  $X$  is indeed a stack!) Now there is a tautological diagram

$$(2-8) \quad \begin{array}{ccc} \{1\} & \longrightarrow & [1, 2] \\ \downarrow & & \downarrow \\ [0, 1] & \longrightarrow & X \end{array}$$

which is not induced by a map  $[0, 2] \rightarrow X$ ; there is no open covering  $[0, 2] = U \cup V$  with  $U \subseteq [0, 1]$  and  $V \subseteq [1, 2]$ . It follows that the diagram (2-7) is not a pushout in the category of all stacks.

**Lemma 2.11** *Let  $\{X_\alpha\}_{\alpha \in A}$  be any diagram of topological spaces and denote its colimit by  $X := \text{colim}_{\alpha \in A} X_\alpha$ . For any topological stack  $T$ , the map*

$$(2-9) \quad \text{Hom}(X, T) \rightarrow \lim_{\alpha \in A} \text{Hom}(X_\alpha, T)$$

*is fully faithful.*

**Proof** We just need to recall the description of  $\text{Hom}(X, T)$  for  $X$  a topological space and  $T$  the stack associated to a topological groupoid  $M \rightrightarrows \mathcal{O}$ . An object of  $\text{Hom}(X, T)$  is an open cover  $X = \bigcup_i U_i$  together with a collection of maps  $\alpha_i : U_i \rightarrow \mathcal{O}$  and  $\beta_{ij} : U_i \cap U_j \rightarrow M$  projecting to  $\alpha_i \times \alpha_j$  and satisfying  $\beta_{ij}\beta_{jk} = \beta_{ik}$  over  $U_i \cap U_j \cap U_k$ . An isomorphism between  $(U_i, \alpha_i, \beta_{ij})$  and  $(U'_i, \alpha'_i, \beta'_{i'j'})$  is a collection of maps  $\gamma_{ii'} : U_i \cap U'_i \rightarrow M$  projecting to  $\alpha_i \times \alpha'_i$ , and satisfying  $\beta_{ij}\gamma_{jj'} = \gamma_{ij'}$  over  $U_i \cap U_j \cap U_{j'}$  and  $\gamma_{ii'}\beta'_{i'j'} = \gamma_{ij'}$  over  $U_i \cap U'_i \cap U_{j'}$ . Composition of isomorphisms relies on the fact that  $\text{Hom}(-, M)$  is a sheaf.

Now fix two objects  $(U_i, \alpha_i, \beta_{ij})$  and  $(U'_i, \alpha'_i, \beta'_{i'j'})$  of  $\text{Hom}(X, T)$ . The set of isomorphisms between them is the set of collections of maps  $\gamma_{ii'} : U_i \cap U'_i \rightarrow M$  satisfying certain compatibility properties. Now we note that for any open subset  $U \subseteq X$ , the map  $\text{colim}_{\alpha \in A} U_\alpha \xrightarrow{\sim} U$  is an isomorphism, where  $U_\alpha$  denotes the inverse image of  $U$  inside  $X_\alpha$ . Thus, since  $M$  is a topological space, the data of maps  $U_i \cap U'_i \rightarrow M$  is equivalent to giving a compatible collection of such maps over the inverse images of  $U_i \cap U'_i$  in each  $X_\alpha$ . Such data is precisely the data of an isomorphism in  $\lim_{\alpha \in A} \text{Hom}(X_\alpha, T)$  between the images of  $(U_i, \alpha_i, \beta_{ij})$  and  $(U'_i, \alpha'_i, \beta'_{i'j'})$ .  $\square$

**Lemma 2.12** *For any topological stack  $X$  with atlas  $U \rightarrow X$ , the functor*

$$(2-10) \quad \text{Hom}(X, T) \xrightarrow{\sim} \text{Eq}(\text{Hom}(U, T) \rightrightarrows \text{Hom}(U \times_X U, T) \rightrightarrows \text{Hom}(U \times_X U \times_X U, T))$$

*is an equivalence for any stack  $T$ . (Concretely, an object on the right is a map  $f : U \rightarrow T$  and an isomorphism  $i : fp_1 \xrightarrow{\sim} fp_2$  in  $\text{Hom}(U \times_X U, T)$  such that the composition of  $i \circ p_{12}$  and  $i \circ p_{23}$  agrees with  $i \circ p_{13}$  in  $\text{Hom}(U \times_X U \times_X U, T)$ , and an isomorphism  $(f, i) \rightarrow (f', i')$  is an isomorphism  $j : f \xrightarrow{\sim} f'$  such that  $i' \circ jp_1 = jp_2 \circ i$ .)*

**Proof** This is similar to the proof of Lemma 2.8. Given a map  $Z \rightarrow X$  from a topological space  $Z$  and an element of the right side of (2-10), we may define a map  $Z \rightarrow T$  as follows. Our map  $Z \rightarrow X$  may be regarded as an open cover of  $Z$ , maps from the elements of the open cover to  $U$ , and maps from pairwise intersections to  $U \times_X U$ , satisfying a cocycle condition. The element of the right side of (2-10) turns this into maps from the elements of the open cover to  $T$  and isomorphisms between them on their pairwise overlaps, satisfying a cocycle condition. The stack property for  $T$  means that this data defines a map  $Z \rightarrow T$ . One now checks that this is a two-sided inverse to (2-10).  $\square$

**Proposition 2.13** *For any representable map of stacks  $A \rightarrow X$  admitting separated étale atlases, the mapping cylinder diagram (2-3) is a pushout in the 2–category of stacks which admit a separated étale atlas.*

**Proof** We are supposed to show that for any stack  $T$  which admits a separated étale atlas, the map

$$(2-11) \quad \text{Hom}(\text{cyl}(A \rightarrow X), T) \rightarrow \text{Hom}(X, T) \times_{\text{Hom}(A, T)} \text{Hom}(A \times [0, 1], T)$$

is an equivalence of groupoids.

We begin with the case that  $X$  and  $A$  are topological spaces. In this case, Lemma 2.11 says that (2-11) is fully faithful, so it remains to prove essential surjectivity. Thus suppose we have maps  $X \rightarrow T$  and  $A \times [0, 1] \rightarrow T$  and an isomorphism between the respective induced maps  $A \rightarrow T$ . We should glue these together into a map  $\text{cyl}(A \rightarrow X) \rightarrow T$ . Fix a separated étale atlas  $O \rightarrow T$ , hence a groupoid presentation  $M \rightrightarrows O$  of  $T$  with  $M = O \times_T O$ . The map  $X \rightarrow T$  thus may be regarded as an open cover  $X = \bigcup_i U_i$ , maps  $U_i \rightarrow O$ , and maps  $U_i \cap U_j \rightarrow M$ , which we may pull back under  $f: A \rightarrow X$  to obtain the map  $A \rightarrow T$ . This map is isomorphic to the restriction to  $A = A \times \{0\}$  of the given map  $A \times [0, 1] \rightarrow T$ , which is a priori defined by a different open cover. Now the key point is the following. Consider one of the open sets  $f^{-1}(U_i) \subseteq A$ , which is equipped with a map  $f^{-1}(U_i) \rightarrow O$ . This map may be regarded as a section over  $f^{-1}(U_i) \subseteq A = A \times \{0\}$  of the separated étale map  $O \times_T (A \times [0, 1]) \rightarrow A \times [0, 1]$ . Since this map is étale, each point  $p \in f^{-1}(U_i)$  has a neighborhood  $V_p \times [0, \varepsilon_p)$  over which the section extends. Since this map is separated and  $[0, \varepsilon_p)$  is connected, these extensions are unique. They hence glue together to give an open set  $V_i \subseteq A \times [0, 1]$  intersecting  $A \times \{0\}$  in  $f^{-1}(U_i)$  such that the map  $f^{-1}(U_i) \rightarrow O$  admits a unique extension to  $V_i$  together with an isomorphism of the

resulting composition to  $T$  with the given map  $A \times [0, 1] \rightarrow T$ . Now  $V_i$  and  $U_i$  define together an open set  $W_i \subseteq \text{cyl}(A \rightarrow X)$ , and we have defined thus a map  $W_i \rightarrow O$ . These  $W_i$ , together with  $A \times (0, 1]$ , cover  $\text{cyl}(A \rightarrow X)$ , so this data defines for us a map  $\text{cyl}(A \rightarrow X) \rightarrow T$  lifting our given data on the right side of (2-11).

Having treated the case that  $X$  and  $A$  are topological spaces, we deduce the general case using Lemma 2.12. Fix an étale atlas  $U \rightarrow X$ , so that  $\text{cyl}(X \rightarrow A)$  is presented by the topological groupoid

$$(2-12) \quad \text{cyl}(A \times_X U \rightarrow U) \times_X U \rightrightarrows \text{cyl}(A \times_X U \rightarrow U).$$

By Lemma 2.12, we conclude that  $\text{cyl}(X \rightarrow A)$  coincides with the coequalizer

$$(2-13) \quad \text{Coeq}(\text{cyl}(A \times_X U \rightarrow U) \rightrightarrows \text{cyl}(A \times_X U \rightarrow U) \times_X U \rightrightarrows \text{cyl}(A \times_X U \rightarrow U) \times_X U \times_X U).$$

Each term in the coequalizer is a cylinder (since  $\times_X U$  is an étale pullback so can be brought inside  $\text{cyl}$ ) of a map of topological spaces. Hence each of these terms is a pushout (in the 2–category of stacks which admit a separated étale atlas). Since coequalizers commute with pushouts, we conclude that  $\text{cyl}(X \rightarrow A)$  is the pushout of

$$(2-14) \quad \begin{array}{c} \text{Coeq}(U \rightrightarrows U \times_X U \rightrightarrows U \times_X U \times_X U) \\ \uparrow \\ \text{Coeq}(A \times_X U \rightrightarrows A \times_X U \times_X U \rightrightarrows A \times_X U \times_X U \times_X U) \\ \downarrow \\ \text{Coeq}(A \times_X U \times [0, 1] \rightrightarrows A \times_X U \times_X U \times [0, 1] \rightrightarrows A \times_X U \times_X U \times_X U \times [0, 1]) \end{array}$$

The top two coequalizers are simply  $X$  and  $A$  by Lemma 2.12. The bottom coequalizer is  $A \times [0, 1]$ , not by pulling out the  $\times [0, 1]$  on general categorical principles, but rather by applying Lemma 2.12 to the atlas  $U \times [0, 1] \rightarrow A \times [0, 1]$ . □

We now combine the results obtained thus far into a general gluing operation:

**Proposition 2.14** *Let  $B \rightarrow C$  be a representable map of orbispaces, and let  $B \hookrightarrow A$  be a closed inclusion which is **collared** in the sense that it factors as*

$$B \xrightarrow{\times\{0\}} B \times [0, 1] \hookrightarrow A,$$

where the second map is an open inclusion. The pushout

$$(2-15) \quad \begin{array}{ccc} B & \longrightarrow & C \\ \downarrow & & \downarrow \\ A & \longrightarrow & A \cup_B C \end{array}$$

exists in the category of stacks admitting a separated étale atlas, and  $A \cup_B C$  is an orbispace.

**Proof** Define  $A \cup_B C$  by gluing  $A \setminus B$  (an open substack of  $A$ ) to  $\text{cyl}(B \rightarrow C)$  along  $B \times (0, 1)$  using a choice of collar  $B \times [0, 2) \hookrightarrow A$ . The fact that  $\text{cyl}(B \rightarrow C)$  is the pushout of  $B \times [0, 1] \leftarrow B \rightarrow C$  (Proposition 2.13) and  $A \cup_B C$  is the pushout of  $\text{cyl}(B \rightarrow C) \leftarrow B \times (0, 1) \hookrightarrow A$  (Lemma 2.8) implies that (2-15) is a pushout. In particular, the gluing  $A \cup_B C$  does not depend on the choice of collar used to construct it. □

We are also interested in countable iterations of such attachment operations. Let us call a map of orbispaces  $X \rightarrow Y$  a *mapping cylinder inclusion* if and only if it is a closed inclusion and admits a factorization of the form  $X \hookrightarrow (X \cup_A (A \times \mathbb{R}_{\geq 0})) \hookrightarrow Y$ , where the second map is an open inclusion and the first map is the natural inclusion of  $X$  into the open substack  $X \cup_A (A \times [0, 1)) \subseteq X \cup_A (A \times [0, 1]) = \text{cyl}(A \rightarrow X)$  for some representable map of orbispaces  $A \rightarrow X$ . Equivalently,  $X \rightarrow Y$  is a mapping cylinder inclusion if and only if it is the right vertical map in some pushout diagram (2-15) (without specifying a choice of such presentation).

**Proposition 2.15** *Let  $X_0 \rightarrow X_1 \rightarrow \dots$  be a sequence of mapping cylinder inclusions of orbispaces. The colimit  $\text{colim}_i X_i$  exists in the category of stacks admitting a separated étale atlas, and this colimit is an orbispace.*

**Proof** We begin with the case that all  $X_i$  are Hausdorff topological spaces, where we show that the colimit in the category of topological spaces  $X := \text{colim}_i X_i$  is the desired colimit. Let us first note that  $X$  is itself Hausdorff. Indeed, let  $p, q$  be distinct points of  $X$ , and choose  $i$  large so that they both lie in  $X_i$ . Since  $X_i$  is Hausdorff, choose disjoint open subsets  $U_p^i$  and  $U_q^i$  of it containing  $p$  and  $q$ , respectively. A factorization of  $X_i \rightarrow X_{i+1}$  witnessing that it is a mapping cylinder inclusion gives disjoint open subsets  $U_p^{i+1}$  and  $U_q^{i+1}$  of  $X_{i+1}$  whose intersections with  $X_i$  are  $U_p^i$  and  $U_q^i$ , respectively. Iterating in this way, we produce disjoint open subsets  $U_p$  and  $U_q$  of  $X$  containing  $p$  and  $q$ , respectively.

Now let us show that for any stack  $T$  admitting a separated étale atlas, the map  $\text{Hom}(X, T) \rightarrow \lim_i \text{Hom}(X_i, T)$  is an equivalence (still in the case  $X_i$  are topological spaces and  $X = \text{colim}_i X_i$  is the colimit in the category of topological spaces). It is fully faithful by Lemma 2.11, so it remains to show essential surjectivity. Choose a separated étale atlas  $U \rightarrow T$ . Fix an object of  $\lim_i \text{Hom}(X_i, T)$ ; this consists, in particular, of open covers  $X_i = \bigcup_j U_{ij}$  and maps  $U_{ij} \rightarrow U$ , with certain descent data on intersections. Now the key step is to note that, as was proven already during the proof of Proposition 2.13, the open sets  $U_{ij}$  covering  $X_i$  extend to  $X_{i+1}$  along with their maps to  $U$ . We may thus construct new open covers of the  $X_i$  by induction as follows: the new open cover of  $X_0$  is simply the one we are given to start with, and the new open cover of  $X_i$  is obtained by taking the new open cover of  $X_{i-1}$ , extending it to a neighborhood of  $X_{i-1}$  inside  $X_i$  as in the proof of Proposition 2.13, and then adding  $X_i \setminus X_{i-1}$  (which is open since  $X_{i-1} \subseteq X_i$  is closed) intersected with all the open sets in the given open cover of  $X_i$ . We thus obtain an open cover of  $X$  and continuous maps from the elements of this open cover to  $U$ , along with the relevant descent data to define a map  $X \rightarrow T$ . This completes the proof in the case that the  $X_i$  are topological spaces.

We now move on to the general case. Note that if  $X \rightarrow Y$  is a mapping cylinder inclusion, then so is  $|X| \rightarrow |Y|$ , since passing to the coarse space preserves open inclusions and mapping cylinders. Hence  $|X_i| \rightarrow |X_{i+1}|$  is a mapping cylinder inclusion. Thus the colimit  $\text{colim}_i |X_i|$  — which must be the coarse space of  $\text{colim}_i X_i$  if it exists — is Hausdorff as above. Now every  $X_i$  maps to  $\text{colim}_i |X_i|$ , and since the latter is Hausdorff, it suffices to prove the statement after restricting to an open cover of  $\text{colim}_i |X_i|$ . Thus fix a point  $p \in \text{colim}_i |X_i|$  and let us prove the statement in a neighborhood of  $p$ . We have  $p \in |X_i|$  for some  $i$ , and let us construct an open neighborhood of  $p$  as in the paragraph above, ie we begin with an open neighborhood  $U^i \subseteq |X_i|$  of  $p$ , we consider  $U^{i+1} \subseteq |X_{i+1}|$  the inverse image of  $U^i$  in the mapping cylinder  $X_i \cup_A (A \times \mathbb{R}_{\geq 0})$ , and iterating gives the desired open neighborhood in the colimit. The effect of restricting to such an open subset is that we have reduced ourselves to the situation of a chain of closed inclusions  $X_0 \hookrightarrow X_1 \hookrightarrow \dots$ , where  $X_{i+1} = X_i \cup_{A_i} (A_i \times \mathbb{R}_{\geq 0})$ .

We may now treat this special case as follows. By restricting further to an open subset of  $X_0$  (and its inverse image in every  $X_i$ ), we may assume without loss of generality that  $X_0 = Y_0/G$  for some Hausdorff space  $Y_0$  acted on by a finite group  $G$ . Pulling back under each projection, we obtain a sequence of inclusions of Hausdorff topological spaces  $Y_0 \hookrightarrow Y_1 \hookrightarrow \dots$ , each with an action of  $G$ , where  $Y_{i+1} = Y_i \cup_{B_i} (B_i \times \mathbb{R}_{\geq 0})$ ,

$G$ -equivariantly, and  $X_i = Y_i/G$ . Now it suffices to show that  $\text{colim}_i(Y_i/G) = (\text{colim}_i Y_i)/G$ ; note that  $\text{colim}_i Y_i$  is Hausdorff, as shown above. Express each  $Y_i/G$  via the topological groupoid  $G \times Y_i \rightrightarrows Y_i$ , and appeal to Lemma 2.12 to see that for any stack  $T$ , we have

$$\begin{aligned}
 (2-16) \quad & \lim_i \text{Hom}(X_i, T) \\
 & \simeq \lim_i \text{Eq}\left(\text{Hom}(Y_i, T) \rightrightarrows \text{Hom}(G \times Y_i, T) \rightrightarrows \text{Hom}(G \times G \times Y_i, T)\right) \\
 & = \text{Eq}\left(\lim_i \text{Hom}(Y_i, T) \rightrightarrows \lim_i \text{Hom}(G \times Y_i, T) \rightrightarrows \lim_i \text{Hom}(G \times G \times Y_i, T)\right).
 \end{aligned}$$

Now for  $T$  admitting a separated étale atlas, we have an equivalence  $\lim_i \text{Hom}(Y_i, T) = \text{Hom}(\text{colim}_i Y_i, T)$  since  $Y_i \hookrightarrow Y_{i+1}$  are mapping cylinder inclusions, and the same holds for  $G \times Y_i$  and  $G \times G \times Y_i$  for the same reason. We also have  $\text{colim}_i(G \times Y_i) = G \times \text{colim}_i Y_i$  since  $G$  is finite (the functor  $\times G$  on topological spaces is cocontinuous whenever  $G$  is locally compact since it then has a right adjoint  $\text{Maps}(G, -)$ ). We therefore have, for  $T$  admitting a separated étale atlas,

$$\begin{aligned}
 (2-17) \quad & \lim_i \text{Hom}(X_i, T) = \\
 & \text{Eq}\left(\text{Hom}(\text{colim}_i Y_i, T) \rightrightarrows \text{Hom}(G \times \text{colim}_i Y_i, T) \rightrightarrows \text{Hom}(G \times G \times \text{colim}_i Y_i, T)\right).
 \end{aligned}$$

Applying Lemma 2.12 once more, we see that the right side is  $\text{Hom}((\text{colim}_i Y_i)/G, T)$ , as was to be shown. □

### 2.4 Orbi-CW-complexes (topology)

We now define *orbi-CW-complexes*. The definition we give realizes in some form a proposal of Gepner and Henriques [18], but differs on some key details. An orbi-CW-complex  $X$  is specified as follows. We begin with the “(-1)-skeleton”  $X_{-1} := \emptyset$ . The  $k$ -skeleton  $X_k$  is defined in terms of  $X_{k-1}$  by attaching cells of the form  $D^k \times \mathbf{B}G$  for finite groups  $G$  along representable attaching maps  $\partial D^k \times \mathbf{B}G \rightarrow X_{k-1}$ . In other words,  $X_k$  is defined as the pushout

$$\begin{array}{ccc}
 \bigsqcup_{\alpha} \partial D^k \times \mathbf{B}G_{\alpha} & \xrightarrow{\bigsqcup_{\alpha} f_{\alpha}} & X_{k-1} \\
 \downarrow & & \downarrow \\
 \bigsqcup_{\alpha} D^k \times \mathbf{B}G_{\alpha} & \longrightarrow & X_k
 \end{array}$$

(2-18)

in the category of topological stacks admitting an étale atlas, which exists by Proposition 2.14, which also guarantees that  $X_k$  is an orbispace. The orbispace  $X$  is now defined as the ascending union

$$(2-19) \quad X := \operatorname{colim}_k X_k,$$

which exists and is an orbispace by Proposition 2.15. Since the coarse space functor  $|\cdot|$  preserves colimits (since it is a left adjoint), it follows that the coarse space of an orbi-CW-complex is a CW-complex, with exactly the same attaching maps.

An orbi-CW-complex is equivalently a pair  $(X, u_{k,\alpha})$  where  $X$  is an orbispace and  $\{u_{k,\alpha}: D^k \times \mathbf{B}G_\alpha \rightarrow X\}_{k,\alpha}$  is a collection of representable maps which satisfy the following inductive condition: the restriction  $u_{k,\alpha}|_{\partial D^k \times \mathbf{B}G_\alpha}$  has image contained in the closed substack  $X_{k-1} \subseteq X$  (begin with  $X_{-1} := \emptyset$ ), the resulting map  $X_k := X_{k-1} \cup_{u_{k,\alpha}} \bigsqcup_\alpha D^k \times \mathbf{B}G_\alpha \rightarrow X$  is a closed inclusion, and  $X$  is the colimit of the closed substacks  $X_k$ .

**Lemma 2.16** *A pair  $(X, u_{k,\alpha})$  consisting of an orbispace  $X$  and a collection of representable maps  $u_{k,\alpha}: D^k \times \mathbf{B}G_\alpha \rightarrow X$  is an orbi-CW-complex if and only if the pair  $(|X|, |u_{k,\alpha}|)$  is a CW-complex and all  $u_{k,\alpha}|_{(D^k)^\circ \times \mathbf{B}G_\alpha}$  induce isomorphisms on isotropy groups.*

**Proof** We show by induction that  $X_k \subseteq X$  is the closed substack corresponding to the closed subset  $|X|_k \subseteq |X|$  induced by the CW-structure  $(|X|, |u_{k,\alpha}|)$ . The image of  $u_{k,\alpha}|_{\partial D^k \times \mathbf{B}G_\alpha}$  is contained in the closed substack  $X_{k-1} \subseteq X$  since this can be checked at the level of coarse spaces. By assumption  $|X|_{k-1} \cup_{|u_{k,\alpha}|} \bigsqcup_\alpha D^k \rightarrow |X|$  is a closed inclusion, and we would like to show that  $X_{k-1} \cup_{u_{k,\alpha}} \bigsqcup_\alpha D^k \times \mathbf{B}G_\alpha \rightarrow X$  is a closed inclusion, with the same image. The coarse space of the domain of the second map coincides with the domain of the first map since coarse space commutes with colimits and  $|X|_{k-1} = |X_{k-1}|$  by the induction hypothesis. The second map therefore factors through the closed substack of  $|X|$  corresponding to  $|X|_k \subseteq |X|$  (the image of the first map, by definition). To check that the first map of this factorization is an isomorphism, it suffices by Lemma 2.3 to note that it induces a homeomorphism on coarse spaces and isomorphisms on isotropy groups (by the hypothesis on  $u_{k,\alpha}|_{(D^k)^\circ \times \mathbf{B}G_\alpha}$ ).

Next, we should show that the map  $\operatorname{colim}_k X_k \rightarrow X$  is an isomorphism. Again by Lemma 2.3, it suffices to note that it induces isomorphisms on isotropy groups (immediate since  $X_k \subseteq X$  are closed substacks) and induces a homeomorphism on coarse spaces (since  $(|X|, |u_{k,\alpha}|)$  is a CW-complex).  $\square$



**Definition 2.17** A subcomplex  $A$  of an orbi-CW-complex  $X$  consists of a subset of the set of cells of  $X$  such that the attaching map of any  $k$ -cell in  $A$  lands inside  $A_{k-1} \subseteq X_{k-1}$ , which is a closed substack by induction on  $k$ . By Lemma 2.16, subcomplexes of  $X$  are in bijection with subcomplexes of  $|X|$ .

Given two orbi-CW-complexes  $(X, u_{k,\alpha})$  and  $(Y, v_{\ell,\beta})$ , we may ask whether their product  $(X \times Y, u_{k,\alpha} \times v_{\ell,\beta})$  is an orbi-CW-complex; note that a product of cells  $D^k \times \mathbf{B}G_\alpha \times D^\ell \times \mathbf{B}G_\beta$  is indeed a cell  $D^{k+\ell} \times \mathbf{B}(G_\alpha \times G_\beta)$ . In view of Lemma 2.16 and Lemma 2.1, this reduces to the corresponding question for the ordinary CW-complexes obtained by passing to coarse spaces. It is known that a product of CW-complexes is a CW-complex if at least one of the factors is locally finite [40] or if both factors are locally countable [26]. (In fact, the question of when a product of two CW-complexes is a CW-complex is completely solved in [7].)

### 3 Homotopy theory of orbispaces

#### 3.1 Homotopies

Two maps of orbispaces  $f, g: X \rightarrow Y$  are called homotopic if and only if there exists a map  $h: X \times [0, 1] \rightarrow Y$  such that  $h(0, \cdot)$  and  $h(1, \cdot)$  are isomorphic to  $f$  and  $g$ , respectively. In particular, if  $f$  and  $g$  are isomorphic, then they are homotopic. Homotopy classes of maps form a set. A map with a two-sided inverse up to homotopy is called a homotopy equivalence.

**Example 3.1** Homotopy classes of maps  $\mathbf{B}G \rightarrow \mathbf{B}H$  are in bijection with conjugacy classes of group homomorphisms  $G \rightarrow H$ . The “space” (properly defined) of maps  $\mathbf{B}G \rightarrow \mathbf{B}H$  would be the homotopy quotient  $\text{Hom}(G, H)//H$ .

**Lemma 3.2** *If  $f$  and  $g$  are homotopic, then  $f$  is representable if and only if  $g$  is representable.*

**Proof** Since for maps of orbispaces, representability is equivalent to injectivity on isotropy groups, it suffices to consider the case of maps from  $\mathbf{B}G$ . Thus, consider a map  $\mathbf{B}G \times [0, 1] \rightarrow Y$ . Locally  $Y = U/\Gamma$  for  $\Gamma$  finite acting on  $U$  Hausdorff. So, a map  $\mathbf{B}G \times [0, 1] \rightarrow Y$  is (locally) a map  $G \rightarrow \Gamma$  and a map  $[0, 1] \rightarrow U$  landing in the  $G$ -fixed locus. This is injective on isotropy groups if and only if  $G \rightarrow \Gamma$  is injective, which is obviously an open and closed condition on  $[0, 1]$ .  $\square$

**Corollary 3.3** *A homotopy equivalence of orbispaces is representable.*

**Proof** Let  $f$  and  $g$  be homotopy inverses of each other. Since  $f \circ g$  and  $g \circ f$  are homotopic to identity maps, they are representable by Lemma 3.2. Thus  $f \circ g$  and  $g \circ f$  are both injective on isotropy groups, from which it follows that  $f$  and  $g$  are injective on isotropy groups.  $\square$

**Lemma 3.4** *Let  $f: Y \times \mathbf{B}G \rightarrow X$  be a map where  $Y$  is a topological space and  $X$  is an orbispace. There exists a partition of  $Y$  into open subsets  $Y_N$  indexed by the normal subgroups  $N \trianglelefteq G$ , **representable** maps  $Y_N \times \mathbf{B}(G/N) \rightarrow X$ , and an isomorphism between  $f$  and the composition*

$$(3-1) \quad Y \times \mathbf{B}G \rightarrow \bigsqcup_{N \trianglelefteq G} Y_N \times \mathbf{B}(G/N) \rightarrow X.$$

*Moreover, this data is unique up to unique isomorphism.*

**Proof** Applying Lemma 2.12 to the atlas  $Y \rightarrow Y \times \mathbf{B}G$ , we find that the data of a map  $Y \times \mathbf{B}G \rightarrow X$  is the same as the data of a map  $f: Y \rightarrow X$  together with a homomorphism  $G \rightarrow \text{Aut}(f)$ . Moreover, for a point  $y \in Y$ , the homomorphism  $G \rightarrow G_{f(y)}$  induced by restricting  $G \rightarrow \text{Aut}(f)$  coincides with the action of the corresponding map  $Y \times \mathbf{B}G \rightarrow X$  on isotropy groups. Now we recall that for maps of orbispaces, representability is equivalent to injectivity on isotropy groups. It thus suffices to show that for any map  $f: Y \rightarrow X$  and any a homomorphism  $G \rightarrow \text{Aut}(f)$ , the map  $y \mapsto \ker(G \rightarrow G_{f(y)})$  is locally constant.

Thus, fix  $f: Y \rightarrow X$  and  $g \in \text{Aut}(f)$ , and let us show that the set of  $y \in Y$  for which  $g|_y \in G_{f(y)}$  is the identity is open and closed. The set of such  $y$  is the fiber product of  $Y$  and  $X$  over  $X \times_{X \times X} X$ . Thus it suffices to show that  $X \rightarrow X \times_{X \times X} X$  is an open and closed inclusion. We can check this locally, so we can assume that  $X = Z/H$  for  $Z$  Hausdorff and  $H$  finite. Then  $X \times_{X \times X} X = (\bigsqcup_{h \in H} X^h)/H$  (the action of  $H$  is by conjugation) and the map from  $X$  is the inclusion of the component  $h = \mathbf{1}$ .  $\square$

### 3.2 Orbi-CW-complexes (homotopy)

The basic objects with which we shall do homotopy theory are orbi-CW-complexes. Many basic facts about CW-complexes generalize immediately to orbi-CW-complexes, with identical proofs. For example, for  $X$  an orbi-CW-complex and  $A \subseteq X$  a sub-complex, the pair  $(X, A)$  has the homotopy extension property — by the universal property of colimits, we may proceed by induction on cells, for which the statement

is obvious since cells have boundary collars. Every map of orbi-CW-complexes is homotopic to one which sends the  $k$ -skeleton of the domain to the  $k$ -skeleton of the target. Also a homotopy equivalence between orbispaces  $X \xrightarrow{\sim} X'$  and homotopies between attaching maps  $\{f_\alpha: \partial D^k \times \mathbf{B}G_\alpha \rightarrow X\}_\alpha$  and  $\{f'_\alpha: \partial D^k \times \mathbf{B}G_\alpha \rightarrow X'\}_\alpha$  induces a homotopy equivalence

$$(3-2) \quad X \cup_{\{f_\alpha\}_\alpha} \bigsqcup_\alpha \partial D^k \times \mathbf{B}G_\alpha \xrightarrow{\sim} X' \cup_{\{f'_\alpha\}_\alpha} \bigsqcup_\alpha \partial D^k \times \mathbf{B}G_\alpha.$$

**Proposition 3.5** *A compact orbifold is homotopy equivalent to a finite orbi-CW-complex.*

**Proof sketch** Let  $X$  be a compact orbifold, and choose a Morse function  $f: X \rightarrow \mathbb{R}$  as follows. We define  $f$  by induction on the stratification of  $X$  by the order of the stabilizer group. A given stratum is a purely ineffective smooth suborbifold, so we just choose any Morse function on it (generic ones are Morse), and we extend it in the normal directions by a *positive definite* quadratic form. Note that in this way, at any critical point, the isotropy group acts trivially on the negative eigenspace of the Hessian. Thus the change in the homotopy type of sublevel sets when passing a critical point of index  $k$  is precisely to attach a cell  $(D^k, \partial D^k) \times \mathbf{B}G$ . □

We now discuss homotopy groups of orbi-CW-complexes. For an orbispace  $X$ , we have a set  $\pi_0^G(X)$  of homotopy classes of maps  $\mathbf{B}G \rightarrow X$ . These are functorial in  $X$  and (contravariantly) in  $G$ . More generally, we define  $\pi_k^G(X, p)$  for a “basepoint”  $p: \mathbf{B}G \rightarrow X$  as the set of maps  $f: S^k \times \mathbf{B}G \rightarrow X$  together with an isomorphism between  $f|_{*\times \mathbf{B}G}$  and  $p$  (where  $*$   $\in S^k$  is a fixed basepoint), modulo homotopy. A homotopy here means a map  $h: [0, 1] \times S^k \times \mathbf{B}G \rightarrow X$  together with an isomorphism between  $h|_{[0,1] \times * \times \mathbf{B}G}$  and  $p \circ \pi_{*\times \mathbf{B}G}$ . The sets  $\pi_k^G(X, p)$  are functorial in  $(X, p)$  and  $G$ . As with ordinary homotopy groups,  $\pi_k^G(X, p)$  is a pointed set for  $k = 0$ , a group for  $k = 1$ , and an abelian group for  $k = 2$ .

**Example 3.6** We have  $\pi_0^G(\mathbf{B}H) = \text{Hom}(G, H)/H$  (quotient by the conjugation action). For a map  $\varphi: G \rightarrow H$  (inducing a basepoint  $\mathbf{B}\varphi: \mathbf{B}G \rightarrow \mathbf{B}H$ ), we have  $\pi_1^G(\mathbf{B}H, \mathbf{B}\varphi) = Z_H(\text{im}(\varphi))$  (the centralizer of  $\varphi(G) \subseteq H$ ) and  $\pi_k^G(\mathbf{B}H, \mathbf{B}\varphi) = 0$  for  $k \geq 2$ .

In view of Lemma 3.2, there is a distinguished subset  $\pi_0^{G,\text{rep}}(X) \subseteq \pi_0^G(X)$  of homotopy classes of representable maps  $\mathbf{B}G \rightarrow X$ . Evidently  $\pi_0^{G,\text{rep}}(X)$  is functorial under

representable maps of  $X$  and injective maps of  $G$ . The sets  $\pi_0^G(X)$  and  $\pi_0^{G,\text{rep}}(X)$  contain the same information, in the sense that

$$(3-3) \quad \pi_0^{G,\text{rep}}(X) = \pi_0^G(X) \setminus \bigcup_{1 \neq N \leq G} \text{im}(\pi_0^{G/N}(X) \rightarrow \pi_0^G(X)),$$

$$(3-4) \quad \pi_0^G(X) = \bigsqcup_{N \leq G} \pi_0^{G/N,\text{rep}}(X).$$

A basepoint  $p: \mathbf{B}G \rightarrow X$  factors uniquely as  $\mathbf{B}G \rightarrow \mathbf{B}(G/\ker p) \xrightarrow{p^{\text{rep}}} X$ , where the second map is representable, and by Lemma 3.4 we have  $\pi_k^G(X, p) = \pi_k^{G/\ker p}(X, p^{\text{rep}})$  for  $k \geq 1$ ; so in this sense the information in the homotopy groups of an orbispace  $X$  is already contained in the case of representable basepoints.

We will also make use of relative homotopy groups  $\pi_k^G(X, Y, p)$  for a map  $Y \rightarrow X$  and a basepoint  $p: \mathbf{B}G \rightarrow Y$ . For  $k \geq 1$ , an element of  $\pi_k(X, Y, p)$  is represented by a diagram

$$(3-5) \quad \begin{array}{ccc} \partial D^k \times \mathbf{B}G & \longrightarrow & Y \\ \downarrow & & \downarrow \\ D^k \times \mathbf{B}G & \longrightarrow & X \end{array}$$

together with an isomorphism between the restriction of  $\partial D^k \times \mathbf{B}G \rightarrow Y$  to  $* \times \mathbf{B}G$  and the basepoint  $p$ . These are considered up to homotopy, ie diagrams in which the orbispaces on the left are replaced with their product with  $[0, 1]$ , and we specify an isomorphism with  $p \circ \pi_{* \times \mathbf{B}G}$  over  $[0, 1] \times * \times \mathbf{B}G$ . Now  $\pi_k^G(X, Y, p)$  is a pointed set for  $k = 1$ , a group for  $k = 2$ , and an abelian group for  $k \geq 3$ .

It is essentially immediate from the definitions that for a map  $Y \rightarrow X$  and a basepoint  $p: \mathbf{B}G \rightarrow Y$ , there is a long exact sequence (of pointed sets)

$$(3-6) \quad \cdots \rightarrow \pi_2^G(X, Y, p) \rightarrow \pi_1^G(Y, p) \rightarrow \pi_1^G(X, p) \rightarrow \pi_1^G(X, Y, p) \rightarrow \pi_0^G(Y, p) \rightarrow \pi_0^G(X, p).$$

It is thus natural to define  $\pi_0^G(X, Y)$  as the pointed set  $\pi_0^G(X)/\pi_0^G(Y)$ . We now have the following version of Whitehead’s theorem.

**Proposition 3.7** *A map of orbi-CW-complexes is a homotopy equivalence if and only if it induces isomorphisms on  $\pi_k^G$  for all basepoints and on  $\pi_0^G$ .*

**Proof** Let  $Y \rightarrow X$  be a map of orbi-CW-complexes which induces an isomorphism on all  $\pi_k^G$ . In view of (3-3), the map  $Y \rightarrow X$  respects the subsets  $\pi_0^{G, \text{rep}} \subseteq \pi_0^G$ . It follows that  $Y \rightarrow X$  is representable.

Since  $Y \rightarrow X$  is representable, we may form its mapping cylinder  $\text{cyl}(Y \rightarrow X)$ ; moreover, by first applying cellular approximation to  $Y \rightarrow X$  to homotope it to be cellular, we may ensure that  $\text{cyl}(Y \rightarrow X)$  is again an orbi-CW-complex.

It now suffices to construct a dotted lift in the diagram

$$(3-7) \quad \begin{array}{ccc} Y & \longrightarrow & Y \\ \downarrow & \nearrow \text{dotted} & \downarrow \\ \text{cyl}(Y \rightarrow X) & \longrightarrow & X \end{array}$$

after possibly homotoping the bottom map  $\text{rel } Y$ . Since  $Y \subseteq \text{cyl}(Y, X)$  is a subcomplex, it is equivalent to solving the homotopy lifting problem

$$(3-8) \quad \begin{array}{ccc} \partial D^k \times \mathbf{BG} & \longrightarrow & Y \\ \downarrow & \nearrow \text{dotted} & \downarrow \\ D^k \times \mathbf{BG} & \longrightarrow & X \end{array}$$

which is equivalent to the vanishing of all relative homotopy groups of  $Y \rightarrow X$ . We are thus done by the long exact sequence (3-6). □

**Conjecture 3.8** Any metrizable locally tame topological orbifold is homotopy equivalent to an orbi-CW-complex.

A first step towards proving this was taken in [29, Proposition 4.6], which shows that there always exists a representable map  $f$  from any paracompact orbispace to the geometric realization of a simplicial complex of groups (which is a particular case of an orbi-CW-complex). The next step would be to argue that, choosing the cover in the proof of this result to be sufficiently fine, it is possible to construct a map  $g$  in the reverse direction (using equivariant contractibility of  $\mathbb{R}^n$  with respect to a linear  $G$ -action) and, moreover, that  $g \circ f$  is homotopic to the identity. One can then add cells to the target of  $f$ , extending  $g$  appropriately, until  $f$  and  $g$  both induce isomorphisms on all  $\pi_k^G$ , and then apply Proposition 3.7 to  $f \circ g$ . This is how the standard proof of the corresponding assertion for topological manifolds goes. That result also extends to absolute neighborhood retracts, so it is natural to ask whether this extension has a generalization to the orbispace setting. One could also reasonably

conjecture that a *compact* locally tame topological orbifold is homotopy equivalent to a *finite* orbi-CW-complex. This is true for manifolds by the work of Kirby and Siebenmann [22; 23], and other proofs were given later by West [39] and Chapman [8]; see Ferry and Ranicki [16] for further discussion.

### 3.3 Homotopy categories of orbispaces

We denote by  $\text{OrbSpc}$  (resp.  $\text{RepOrbSpc}$ ) the category whose objects are orbi-CW-complexes and whose morphisms are (resp. representable) homotopy classes of maps. By Lemma 3.2, representability is preserved by homotopies, and a homotopy between representable maps is itself representable. The tautological functor  $\text{RepOrbSpc} \rightarrow \text{OrbSpc}$  is thus faithful and conservative. The homotopy category of CW-complexes is denoted by  $\text{Spc}$ , which is a full subcategory of both  $\text{RepOrbSpc}$  and  $\text{OrbSpc}$ .

The functor  $\text{Spc} \hookrightarrow \text{OrbSpc}$  has a left adjoint, namely the coarse space functor  $|\cdot|: \text{OrbSpc} \rightarrow \text{Spc}$ , which sends orbi-CW-complexes to CW-complexes, as noted earlier.

We use  $\text{Spc}^f \subseteq \text{Spc}$ ,  $\text{RepOrbSpc}^f \subseteq \text{RepOrbSpc}$  and  $\text{OrbSpc}^f \subseteq \text{OrbSpc}$  to denote the full subcategories spanned by finite (orbi-)CW-complexes. Note that the adjectives “finite” or “compact”, and the resulting notation for full subcategories, sometimes are used to indicate instead those objects which are compact objects in the categorical sense; finite orbi-CW-complexes are compact objects categorically, but the converse is not true.

### 3.4 Classifying space

The inclusion  $\text{Spc} \hookrightarrow \text{OrbSpc}$  has a right adjoint denoted by  $X \mapsto \tilde{X}$ , where  $\tilde{X}$  is known as the *classifying space* of  $X$ . This right adjoint may be constructed as follows. It suffices to show that for any orbi-CW-complex  $X$ , there exists a CW-complex  $\tilde{X}$  and a map  $\tilde{X} \rightarrow X$  such that the homotopy lifting problem

$$(3-9) \quad \begin{array}{ccc} \partial D^k & \longrightarrow & \tilde{X} \\ \downarrow & \nearrow & \downarrow \\ D^k & \longrightarrow & X \end{array}$$

always has a solution. Indeed, this implies that the map  $\tilde{X} \rightarrow X$  induces a bijection between homotopy classes of maps  $Y \rightarrow \tilde{X}$  and homotopy classes of maps  $Y \rightarrow X$

for any CW-complex  $Y$ . We may construct  $\tilde{X}$  as follows. We begin with  $\tilde{X}_{-1} = \emptyset$ . We define  $\tilde{X}_k$  from  $\tilde{X}_{k-1}$  by attaching a  $k$ -cell for every element of  $\pi_k(X, \tilde{X}_{k-1})$  (for every basepoint when  $k > 0$ ). By cellular approximation and induction, we have  $\pi_i(X, \tilde{X}_k) = 0$  for all  $i \leq k$ . It follows that  $\pi_i(X, \tilde{X}) = 0$  for every  $i$ , which is equivalent to solvability of the above lifting problem.

**Example 3.9** For a CW-complex  $X$ , the set of homotopy classes of maps  $X \rightarrow \mathbf{B}G$  is in natural bijection with the set of isomorphism classes of principal  $G$ -bundles over  $X$ , which is in turn in bijection with the set of homotopy classes of maps  $X \rightarrow BG$ . It follows that  $\widetilde{\mathbf{B}G} = BG$ .

The natural map  $(X \times Y)^\sim \rightarrow \tilde{X} \times \tilde{Y}$  is an isomorphism since  $X \mapsto \tilde{X}$  is a right adjoint.

**Lemma 3.10** *Let  $X$  be an orbi-CW-complex covered by subcomplexes  $P, Q \subseteq X$  intersecting in  $A := P \cap Q$ , so  $X = P \cup_A Q$ . Fix classifying spaces  $\tilde{P} \rightarrow P, \tilde{Q} \rightarrow Q$  and  $\tilde{A} \rightarrow A$ , with subcomplex inclusions  $\tilde{A} \rightarrow \tilde{P}$  and  $\tilde{A} \rightarrow \tilde{Q}$  such that the diagram*

$$(3-10) \quad \begin{array}{ccccc} \tilde{P} & \longleftarrow & \tilde{A} & \longrightarrow & \tilde{Q} \\ \downarrow & & \downarrow & & \downarrow \\ P & \longleftarrow & A & \longrightarrow & Q \end{array}$$

*strictly commutes; this may be achieved by replacing  $\tilde{P}$  and  $\tilde{Q}$  by the mapping cylinders of  $\tilde{A} \rightarrow \tilde{P}$  and  $\tilde{A} \rightarrow \tilde{Q}$ . Then  $\tilde{X} = \tilde{P} \cup_{\tilde{A}} \tilde{Q}$  with the obvious map to  $P \cup_A Q = X$ .*

**Proof** Given a CW-complex  $Z$  and a map  $Z \rightarrow X = P \cup_A Q$ , let us lift it (up to homotopy) to  $\tilde{P} \cup_{\tilde{A}} \tilde{Q}$ . By subdividing  $Z$  and homotoping the map  $Z \rightarrow X$ , we may assume that each cell of  $Z$  maps either entirely to  $P$  or entirely to  $Q$ . Now we first lift the cells which map to  $A = P \cap Q$  to  $\tilde{A}$ . A cell which maps to  $P$  (resp.  $Q$ ) but not entirely to  $A$  is now lifted to  $\tilde{P}$  (resp.  $\tilde{Q}$ ). This shows that the map from homotopy classes of maps  $Z \rightarrow \tilde{P} \cup_{\tilde{A}} \tilde{Q}$  to homotopy classes of maps  $Z \rightarrow X = P \cup_A Q$  is surjective. To show injectivity, apply the same argument rel boundary to a homotopy between the compositions of two maps  $Z \rightarrow \tilde{P} \cup_{\tilde{A}} \tilde{Q}$  with  $\tilde{P} \cup_{\tilde{A}} \tilde{Q} \rightarrow P \cup_A Q$ . Note that in this proof we used the lifting property (3-9), which is a priori stronger than (albeit a posteriori equivalent to) the adjointness property of the classifying space at the level of homotopy categories; the lifting property instead corresponds to a universal property at the  $\infty$ -category level. □

One can similarly argue by induction on cells that one can construct  $\tilde{X}$  by taking each cell  $(D^k, \partial D^k) \times \mathbf{B}G$  of  $X$  and replacing it with  $(D^k, \partial D^k) \times \mathbf{B}G$  and attaching as appropriate.

**Remark 3.11** There are other, more point set topological, definitions of the classifying space of more general topological stacks. These include taking  $\tilde{X}$  to be the nerve of the simplicial space  $[p] \mapsto U \times_X \cdots \times_X U$  ( $p + 1$  times), where  $U \rightarrow X$  is a suitable atlas. It is also possible to define  $\tilde{X} \rightarrow X$  by the universal property that  $\tilde{X} \times_X Z \rightarrow Z$  should be “fiberwise contractible” for any topological space  $Z$  mapping to  $X$ ; compare Noohi [28]. We will not make either of these definitions precise, nor prove that they give the right adjoint of  $\mathbf{Spc} \hookrightarrow \mathbf{OrbSpc}$ , though this is also possible.

### 3.5 Right adjoint

Here is another adjoint.

**Proposition 3.12** *The functor  $\mathbf{RepOrbSpc} \rightarrow \mathbf{OrbSpc}$  has a right adjoint  $R$ .*

**Proof** It suffices to show that for every orbi-CW-complex  $X$ , there exists an orbi-CW-complex  $R(X)$  and a map  $R(X) \rightarrow X$  such that for every commuting diagram of solid arrows

$$(3-11) \quad \begin{array}{ccc} \partial D^k \times \mathbf{B}G & \xrightarrow{\text{rep}} & R(X) \\ \downarrow & \nearrow \text{rep} & \downarrow \\ D^k \times \mathbf{B}G & \longrightarrow & X \end{array}$$

there exists, after possibly homotoping the bottom map rel boundary, a dotted lift. Indeed, given such a map  $R(X) \rightarrow X$ , it follows (by induction on cells) that the induced map  $\mathbf{RepOrbSpc}(Z, R(X)) \rightarrow \mathbf{OrbSpc}(Z, X)$  is a bijection, which implies that the adjoint  $R$  exists as a functor.

We may now construct the orbi-CW-complex  $R(X)$  inductively, just as we constructed  $\tilde{X}$  above. We begin with  $R(X)_{-1} = \emptyset$ , and we define  $R(X)_k$  by attaching copies of  $D^k \times \mathbf{B}G$  to  $R(X)_{k-1}$  along the upper horizontal maps in some set of diagrams (3-11) with  $R(X)_{k-1}$  in place of  $R(X)$  representing every homotopy class of such; note that the attaching maps are by definition representable. Using cellular approximation and induction, it follows that  $R(X)_r$  satisfies the desired lifting property (3-11) for all  $k \leq r$ ; hence  $R(X)$  is as desired. □



The proof of Proposition 3.12 given above shows existence, but is not so amenable to computation. So, let us sketch what we expect is a more concrete definition of the functor  $R: \text{OrbSpc} \rightarrow \text{RepOrbSpc}$ , without claiming to give a complete proof. We define a functor  $R: \text{OrbSpc} \rightarrow \text{RepOrbSpc}$  as

$$(3-12) \quad R(X) := \bigsqcup_{G_0 \hookrightarrow \dots \hookrightarrow G_p} \Delta^p \times \mathbf{B}G_0 \times \widetilde{\text{Maps}}(\mathbf{B}G_p, X) / \sim.$$

The reader may recognize this formula as a “homotopy coend”. Here  $\widetilde{\text{Maps}}(\mathbf{B}G, X)$  denotes the classifying space of the mapping orbispace  $\text{Maps}(\mathbf{B}G, X)$ , which is defined by the universal property that a map  $Y \rightarrow \text{Maps}(\mathbf{B}G, X)$  is the same as a map  $Y \times \mathbf{B}G \rightarrow X$ . When  $X$  is an orbi-CW-complex, one can instead be much more concrete:  $\widetilde{\text{Maps}}(\mathbf{B}G, X)$  may be defined by replacing each cell  $D^k \times \mathbf{B}H$  in  $X$  with  $D^k \times \text{Hom}(G, H) // H$ , where  $H \curvearrowright \text{Hom}(G, H)$  by conjugation and  $//$  denotes the homotopy quotient. Now (3-12) is meant to be modeled on the nerve of the 2-category  $\text{InjFinGrp}$  of finite groups, injective homomorphisms and conjugations; the quotient  $\sim$  indicates the colimit over the natural face and degeneracy identifications.

**Conjecture 3.13** The expression (3-12) defines a functor  $R: \text{OrbSpc} \rightarrow \text{RepOrbSpc}$ , which is right adjoint to  $\text{RepOrbSpc} \rightarrow \text{OrbSpc}$ .

**Proof sketch** There is a tautological map  $R(X) \rightarrow X$ , and it suffices to show that the induced map

$$(3-13) \quad \widetilde{\text{RepMaps}}(\mathbf{B}G, R(X)) \rightarrow \widetilde{\text{Maps}}(\mathbf{B}G, X)$$

is a homotopy equivalence. Now  $\widetilde{\text{RepMaps}}(\mathbf{B}G, R(X))$  is given by

$$(3-14) \quad \bigsqcup_{G_0 \hookrightarrow \dots \hookrightarrow G_p} \Delta^p \times \widetilde{\text{RepMaps}}(\mathbf{B}G, \mathbf{B}G_0) \times \widetilde{\text{Maps}}(\mathbf{B}G_p, X) / \sim.$$

Now  $\widetilde{\text{RepMaps}}(\mathbf{B}G, \mathbf{B}G_0)$  is just the classifying space of the groupoid of morphisms  $G \rightarrow G_0$  in  $\text{InjFinGrp}$ , so we can equivalently write this as

$$(3-15) \quad \bigsqcup_{G \hookrightarrow G_0 \hookrightarrow \dots \hookrightarrow G_p} \Delta^p \times \widetilde{\text{Maps}}(\mathbf{B}G_p, X) / \sim.$$

This being a homotopy colimit over a category with an initial object simply reduces to  $\widetilde{\text{Maps}}(\mathbf{B}G, X)$ , as desired. □

The space  $R(*) \in \text{RepOrbSpc}$  is the terminal object, and so may be expected to play a role in the homotopy theory of orbispaces; see eg Conjectures 3.14 and 3.34. It is characterized by the universal property that the space of representable maps to it is contractible, in the precise sense that  $\pi_0^{G, \text{rep}}(R(*)) = *$  for all  $G$ , and  $\pi_k^G(R(*), p) = 0$  for representable, hence all, basepoints  $p$ . Combining this with Lemma 3.4 implies that the space of all (not necessarily representable) maps from  $\mathbf{BG}$  to  $R(*)$  is homotopy equivalent to the (discrete) set of normal subgroups of  $G$ . It follows that  $R(*)$  is, in Rezk’s language [32], the normal subgroup classifier  $\mathcal{N}$ ; more precisely, the tautological functor  $\text{RepOrbSpc} \rightarrow \text{OrbSpc}$  sends  $R(*) \in \text{RepOrbSpc}$  to  $\mathcal{N} \in \text{OrbSpc}$  — from our perspective, the categories  $\text{RepOrbSpc}$  and  $\text{OrbSpc}$  have the “same” objects, namely orbi-CW-complexes, so it makes sense to simply say that  $R(*)$  is  $\mathcal{N}$ , however in Rezk’s setup the functor  $R: \text{OrbSpc} \rightarrow \text{RepOrbSpc}$  is the more natural one, being given by a restriction of presheaves, so the use of its left adjoint  $\text{RepOrbSpc} \rightarrow \text{OrbSpc}$  becomes more significant.

Specializing (3-12) gives

$$(3-16) \quad R(*) = \bigsqcup_{G_0 \hookrightarrow \dots \hookrightarrow G_p} \Delta^p \times \mathbf{BG}_0 / \sim,$$

which is an orbi-CW-complex, and one can follow the proof sketch above to see that it is indeed  $R(*)$ . Since every object of  $\text{RepOrbSpc}$  admits a unique up to homotopy representable map to  $R(*)$ , we may think of objects of  $\text{RepOrbSpc}$  informally as being “representable over  $R(*)$ ”. More precisely, we make the following conjecture, a form of which is proven by Rezk [32, Proposition 4.6.1]:

**Conjecture 3.14** The category  $\text{RepOrbSpc}$  is equivalent to the category of representable fibrations over  $R(*)$  (with reasonable fibers).

We can specify this further: the equivalence should send a representable fibration over  $R(*)$  to its total space, and the fiber over a generic point of  $R(*)$  should be the classifying space  $\tilde{X}$  of the orbispace  $X$ . There are also interesting functors to  $G$ -spaces given by pulling back under the unique up to contractible choice representable map  $\mathbf{BG} \rightarrow R(*)$ . In fact, it seems that fibrations over  $R(*)$  should be the same (in the  $\infty$ -categorical context) as  $\text{PSh}(\text{Rep}\{\mathbf{BG}\})$ , where  $\text{Rep}\{\mathbf{BG}\} \subseteq \text{RepOrbSpc}$  denotes the full subcategory spanned by the objects  $\mathbf{BG}$ , and  $\text{PSh}$  denotes presheaves. The proposed formula (3-12) and the sketch of proof of Conjecture 3.13 in fact would apply to define an inverse of the restricted Yoneda functor  $\text{RepOrbSpc} \rightarrow \text{PSh}(\text{Rep}\{\mathbf{BG}\})$ .

### 3.6 Homotopy categories of relative orbispaces

We now introduce categories  $\text{OrbSpc}_*$  and  $\text{RepOrbSpc}_*$  of “relative orbispaces”. These categories should be thought of as analogues of the category  $\text{Spc}_*$  of pointed CW-complexes and homotopy classes of pointed maps. They are, however, *not* the (representable) homotopy categories of pointed orbi-CW-complexes and homotopy classes of pointed maps. The reason that pointed orbi-CW-complexes and pointed maps are not what we want to consider may be traced back to the fact that there is no well-defined quotient orbi-CW-complex  $X/A$  of a given orbi-CW-pair  $(X, A)$ .

We begin with the categories of orbi-CW-pairs  $\text{OrbSpcPair}$  and  $\text{RepOrbSpcPair}$ , whose objects are orbi-CW-pairs  $(X, A)$  (meaning  $X$  is an orbi-CW-complex and  $A \subseteq X$  is a subcomplex), and whose morphisms  $(X, A) \rightarrow (Y, B)$  are (representable) commutative squares. Product of pairs is defined as usual,

$$(X, A) \times (Y, B) := (X \times Y, (A \times Y) \cup (X \times B)),$$

as is the notion of homotopies between maps of pairs.

Now the categories  $\text{OrbSpc}_*$  and  $\text{RepOrbSpc}_*$  of “relative orbispaces” are defined as follows. The objects are again orbi-CW-pairs  $(X, A)$ . A “relative map” of orbi-CW-pairs  $(X, A) \dashrightarrow (Y, B)$  consists of a closed set  $A \subseteq A^+ \subseteq X$ , an open set  $U \subseteq X$  with  $X = U \cup (A^+)^{\circ}$  and a map of pairs  $(U, U \cap A^+) \rightarrow (Y, B)$ . The composition of two relative maps

$$(3-17) \quad (X, A) \dashrightarrow^{(A^+, U, f)} (Y, B) \dashrightarrow^{(B^+, V, g)} (Z, C)$$

is the triple

$$(A^+ \cup f^{-1}(B^+), f^{-1}(V), g \circ f),$$

and composition is associative. A homotopy between relative maps is a relative map  $(X, A) \times [0, 1] \rightarrow (Y, B)$ . The morphisms in  $\text{OrbSpc}_*$  and  $\text{RepOrbSpc}_*$  are (representable) relative maps modulo (representable) homotopy. Note that it is not true that representability is preserved under homotopy, nor that a homotopy between representable maps is necessarily representable. There is a tautological functor

$$(3-18) \quad \text{RepOrbSpc}_* \rightarrow \text{OrbSpc}_*,$$

which is not faithful. The homotopy category of pointed CW-complexes  $\text{Spc}_*$  is a full subcategory of both  $\text{RepOrbSpc}_*$  and  $\text{OrbSpc}_*$ .

**Proposition 3.15** (excision) *The functors*

$$(3-19) \quad \text{OrbSpcPair} \rightarrow \text{OrbSpc}_*$$

$$(3-20) \quad \text{RepOrbSpcPair} \rightarrow \text{RepOrbSpc}_*,$$

are localizations at the collection  $W$  of morphisms of the form  $(P, P \cap Q) \rightarrow (X, Q)$ , where  $X = P \cup Q$  is a cover by subcomplexes.

The same holds if we restrict both sides to the full subcategories spanned by finite orbi-CW-pairs.

**Proof** First note that the morphisms  $W$  in  $\text{RepOrbSpcPair}$  do indeed become isomorphisms in  $\text{RepOrbSpc}_*$  (hence also in  $\text{OrbSpc}_*$ ). Indeed, such morphisms are, up to isomorphism in  $\text{RepOrbSpcPair}$ , of the form

$$(3-21) \quad (X, A) \rightarrow (X \cup_{B \times \{0\}} (B \times [0, 1]) \cup_{B \times \{1\}} Y, A \cup_{B \times \{0\}} (B \times [0, 1]) \cup_{B \times \{1\}} Y),$$

and these have an evident inverse up to homotopy in  $\text{RepOrbSpc}_*$ .

We now show that  $\text{OrbSpcPair} \rightarrow \text{OrbSpc}_*$  satisfies the universal property of localization at  $W$ , namely that for any functor  $\text{OrbSpcPair} \rightarrow \mathcal{C}$  which sends all morphisms in  $W$  to isomorphisms factors uniquely up to unique isomorphism through  $\text{OrbSpc}_*$  (and the same for  $\text{RepOrbSpcPair} \rightarrow \text{RepOrbSpc}_*$ ). Let  $F: \text{OrbSpcPair} \rightarrow \mathcal{C}$  be given. The action of  $\tilde{F}$  on objects is fixed since  $\text{OrbSpcPair} \rightarrow \text{OrbSpc}_*$  is essentially surjective. We are thus reduced to showing that there exists a unique collection of maps

$$\tilde{F}: \text{OrbSpc}_*((X, A), (Y, B)) \rightarrow \mathcal{C}(F(X, A), F(Y, B))$$

factoring  $F$ , which are compatible with composition.

Given a map  $(A^+, U, f): (X, A) \rightarrow (Y, B)$  in  $\text{OrbSpc}_*$ , it factors as

$$(3-22) \quad (X, A) \rightarrow (X, A^+) \xleftarrow{W} (U, U \cap A^+) \xrightarrow{f} (Y, B).$$

By subdividing  $X$ , we may shrink  $U \subseteq X$  and  $A^+ \subseteq X$  to be subcomplexes covering  $X$ ; so  $U$  is, in particular, likely no longer open. Since  $F$  sends  $W$  to isomorphisms it follows that  $\tilde{F}$  applied to this map is determined uniquely by  $F$ . It is a tautology that  $\tilde{F}(A^+, U, f)$  defined in this way is invariant under homotopy of  $(A^+, U, f)$ , simply because the two maps  $(X, A) \rightarrow (X \times [0, 1], A \times [0, 1])$  coincide in  $\text{RepOrbSpcPair}$ .

Finally, we should check that  $\tilde{F}$  respects composition; this follows from the commuting diagram

$$\begin{array}{ccc}
 & & (X, A) \\
 & \swarrow & \downarrow \\
 & (X, A^+ \cup f^{-1}(B^+)) & \longleftarrow (X, A^+) \\
 & \uparrow w & \uparrow w \\
 & (U, U \cap (A^+ \cup f^{-1}(B^+))) & \longleftarrow (U, U \cap A^+) \\
 (3-23) & \uparrow w & \searrow f \quad \downarrow f \\
 & (f^{-1}(V), f^{-1}(V) \cap (A^+ \cup f^{-1}(B^+))) & \longrightarrow (Y, B^+) \\
 & \searrow f & \uparrow w \\
 & & (V, V \cap B^+) \\
 & & \downarrow g \\
 & & (Z, C)
 \end{array}$$

The point here is that once the maps  $W$  are declared to be isomorphisms, commutativity of the diagram implies (being careful about the directions of the maps) that the rightmost vertical composition coincides with the leftmost vertical composition.

To see that the same holds after restricting to finite orbi-CW-pairs, we just need to observe that if the input orbi-CW-pairs in the above proof are all finite, then the additional orbi-CW-pairs appearing in the intermediate constructions can also be taken to be finite. □

The functor  $\text{Spc}_* \rightarrow \text{OrbSpc}_*$  has both adjoints. The existence of the left adjoint (the coarse space) is immediate — send an orbi-CW-pair  $(X, A)$  to the CW-pair  $(|X|, |A|)$ . For the existence of the right adjoint (the classifying space), we argue as in Lemma 3.10. Given an orbi-CW-complex  $(X, A)$ , we may find classifying spaces  $\tilde{X} \rightarrow X$  and  $\tilde{A} \rightarrow A$  so that  $\tilde{A} \subseteq \tilde{X}$  is a subcomplex and the classifying maps together define a map of pairs  $(\tilde{X}, \tilde{A}) \rightarrow (X, A)$ . The argument of the proof of Lemma 3.10 then shows that this map exhibits  $(\tilde{X}, \tilde{A})$  as the classifying space of  $(X, A)$ .

There is a symmetric monoidal “smash product”  $\wedge$  on  $\text{RepOrbSpc}_*^f$  and  $\text{OrbSpc}_*^f$ , defined as follows. Product of finite orbi-CW-pairs

$$(X, A) \times (Y, B) := (X \times Y, (A \times Y) \cup (X \times B))$$

is a symmetric monoidal structure on  $\text{RepOrbSpcPair}^f$  and  $\text{OrbSpcPair}^f$ . To see that it descends to  $\text{RepOrbSpc}_*^f$  and  $\text{OrbSpc}_*^f$ , it suffices by Proposition 3.15 to note that  $(P, P \cap Q) \times (Y, B) \rightarrow (X, Q) \times (Y, B)$  is again of the form  $(P', P' \cap Q') \rightarrow (X', Q')$ , namely

$$X' = X \times Y, \quad P' = P \times Y \quad \text{and} \quad Q' = (Q \times Y) \cup (X \times B).$$

Let us argue that there is a natural isomorphism  $(Z \wedge W)^\sim = \tilde{Z} \wedge \tilde{W}$ . If  $Z = (X, A)$  and  $W = (Y, B)$ , then, recalling that the classifying space of  $(X, A)$  is  $(\tilde{X}, \tilde{A})$ , this is the assertion that

$$(3-24) \quad ((X \times Y)^\sim, ((A \times Y) \cup_{A \times B} (X \times B))^\sim) = (\tilde{X} \times \tilde{Y}, (\tilde{A} \times \tilde{Y}) \cup_{\tilde{A} \times \tilde{B}} (\tilde{X} \times \tilde{B})),$$

which follows from Lemma 3.10 and the fact that classifying space commutes with products.

Given any  $\infty$ -category such as (the  $\infty$ -categorical refinement of)  $\text{RepOrbSpc}$ , there is an  $\infty$ -category of “pointed objects of  $\text{RepOrbSpc}$ ”, namely the under-category of the terminal object, in this case  $R(*)$ . It is reasonable to expect this yields the same result as our explicit geometric definition of the category of relative orbispaces:

**Conjecture 3.16** There is an equivalence

$$\text{RepOrbSpc}_* = \text{RepOrbSpc}_{R(*)}/$$

as  $\infty$ -categories.

**Conjecture 3.17** The category  $\text{RepOrbSpc}_*$  is equivalent to the category of pointed representable fibrations over  $R(*)$  and to the category of presheaves of pointed spaces on  $\text{Rep}\{\mathbf{BG}\}$ .

### 3.7 Cofiber sequences

A *cofiber sequence* in  $\text{RepOrbSpc}_*$  is a three-term sequence isomorphic to

$$(3-25) \quad (Y, B) \rightarrow (X, A) \rightarrow (X, A \cup_B Y)$$

for an orbi-CW-complex  $X$  with two subcomplexes  $A, Y \subseteq X$  and  $B := A \cap Y$ .

**Proposition 3.18** Every morphism  $X \rightarrow Y$  in  $\text{RepOrbSpc}_*$  extends to a cofiber sequence  $X \rightarrow Y \rightarrow Z$ .

**Proof** Equivalently, we are to show that every morphism in  $\text{RepOrbSpc}_*$  is isomorphic to an inclusion  $(Y, B) \hookrightarrow (X, A)$ , where  $X$  is an orbi-CW-complex,  $A, Y \subseteq X$  are subcomplexes and  $B = Y \cap A$ .

First, note that any map of orbi-CW-pairs  $(X, A) \rightarrow (Y, B)$  may be replaced by a map of the desired form by first homotoping it to be cellular and then considering  $(X, A) \rightarrow (\text{cyl}(X \rightarrow Y), \text{cyl}(A \rightarrow B))$ . Thus it suffices to show that every morphism in  $\text{RepOrbSpc}_*$  is isomorphic to the image of a morphism in  $\text{RepOrbSpcPair}$ .

A general morphism in  $\text{RepOrbSpc}_*$  may be expressed in terms of morphisms of orbi-CW-pairs as

$$(3-26) \quad (X, A) \rightarrow (X, A^+) \xleftarrow{\simeq} (V, V \cap A^+) \rightarrow (Y, B),$$

where  $X$  is an orbi-CW-complex,  $A^+, V \subseteq X$  are subcomplexes, and  $X = V \cup A^+$ . We now consider the gluing

$$(3-27) \quad (X, A^+) \cup ((V, V \cap A^+) \times I) \cup (Y, B).$$

The inclusion of  $\text{cyl}((V, V \cap A^+) \rightarrow (Y, B))$ —hence also of  $(Y, B)$ —into this orbi-CW-pair is an isomorphism in  $\text{RepOrbSpc}_*$  by Proposition 3.15. Thus the natural map from  $(X, A)$  to (3-27) is a map of orbi-CW-pairs, which becomes isomorphic to our given morphism in  $\text{RepOrbSpc}_*$ .  $\square$

In fact, a quadruple  $(X, A, Y, B)$  as above determines not only a three-term sequence (3-25), but a half-infinite sequence, each of whose consecutive pairs of morphisms form cofiber sequences. This so-called ‘‘Puppe sequence’’ takes the form

$$(3-28) \quad \cdots \dashrightarrow (Y, B) \times (I^k, \partial I^k) \rightarrow (X, A) \times (I^k, \partial I^k) \rightarrow (X, A \cup Y) \times (I^k, \partial I^k) \dashrightarrow \cdots,$$

where the ‘‘connecting maps’’

$$(3-29) \quad (X, A \cup Y) \times (I^k, \partial I^k) \dashrightarrow (Y, B) \times (I^{k+1}, \partial I^{k+1})$$

are defined as  $(r, \text{id}_{I^k}, \varphi)$ , where  $r: (X, A \cup Y) \rightarrow (Y, B)$  is a retraction defined in a neighborhood of  $(Y, B)$ , and  $\varphi: X \rightarrow [0, 1]$  is a map which equals 1 on  $Y$  and equals 0 outside a small neighborhood of  $Y$ .

**Proposition 3.19** *Every consecutive triple in the Puppe sequence is a cofiber sequence.*

**Proof** The three consecutive terms appearing in (3-28) certainly form a cofiber sequence. Shifting forward by one, we have a cofiber sequence

$$(3-30) \quad (X, A) \times (I^k, \partial I^k) \xrightarrow{\times\{0\}} (X \times I, (A \times I) \cup (Y \times \{1\})) \times (I^k, \partial I^k) \\ \rightarrow (X \times I, (X \times \{0\}) \cup (A \times I) \cup (Y \times \{1\})) \times (I^k, \partial I^k),$$

into whose third term  $(Y, B) \times (I, \partial I) \times (I^k, \partial I^k)$  includes isomorphically. Shifting forward by one again, we have a cofiber sequence

$$(3-31) \quad (X \times [\frac{1}{2}, 1], (A \times [\frac{1}{2}, 1]) \cup (Y \times \{1\})) \times (I^k, \partial I^k) \\ \rightarrow (X \times I, (X \times \{0\}) \cup (A \times I) \cup (Y \times \{1\})) \times (I^k, \partial I^k) \\ \dashrightarrow (X \times [0, \frac{1}{2}], (X \times \{0\}) \cup (A \times [0, \frac{1}{2}]) \cup (X \times \{\frac{1}{2}\})) \times (I^k, \partial I^k).$$

This concludes the proof. □

**Example 3.20** Here is an example to show that there is no similar notion of cofiber sequences in  $\text{OrbSpc}_*$ . Consider the map  $\mathbf{BG} \rightarrow *$ ; this is a map in  $\text{OrbSpc}$ , and we consider its image in  $\text{OrbSpc}_*$  under the natural map  $\text{OrbSpc} \rightarrow \text{OrbSpc}_*$  given by “disjoint union with a basepoint”. Suppose it has a cofiber  $\mathbf{BG} \rightarrow * \rightarrow X$ , where  $X \in \text{OrbSpc}_*$ . Now the defining property of the cofiber is that for any  $Y \in \text{OrbSpc}_*$ , a map  $X \rightarrow Y$  is the same thing as a map  $* \rightarrow Y$  and a nullhomotopy of the composition  $\mathbf{BG} \rightarrow * \rightarrow Y$ . On the other hand, a nullhomotopy of this composition induces a nullhomotopy of the original map  $* \rightarrow Y$ , by Lemma 3.4. Thus there is a unique map  $X \rightarrow Y$ , namely the zero map (sending everything to the basepoint). It follows that  $X = \emptyset$  is the terminal object of  $\text{OrbSpc}_*$ . Now if we additionally suppose that our cofiber sequence extends as the Puppe sequence to give  $\mathbf{BG} \rightarrow * \rightarrow X \rightarrow \mathbf{BG} \times (I, \partial I) \rightarrow (I, \partial I)$ , we obtain a contradiction, since  $X = \emptyset$ , so the cofiber of  $X \rightarrow Z$  is  $Z$  for any  $Z \in \text{OrbSpc}_*$ . The key point in this argument was the use of Lemma 3.4.

### 3.8 Enough vector bundles

We now recall the “enough vector bundles property” proved in [29], which underlies most of our subsequent work in this paper. We also derive some corollaries which we will also need.

We begin with some definitions. By “vector bundle” we will always mean a finite-dimensional vector bundle. Recall that for any vector bundle  $V$  over an orbispace  $X$ , the fiber over a point  $p: * \rightarrow X$  is a vector space  $V_p$  which carries a linear action



of the isotropy group  $G_p$  of  $p$ . A vector bundle is called *coarse* if and only if these isotropy representations  $G_p \curvearrowright V_p$  are all trivial—this is equivalent to  $V$  being pulled back from the coarse space  $|X|$ , hence the terminology. A vector bundle is called *faithful* if and only if the isotropy representations are all faithful. A vector bundle is called *module faithful* if and only if each  $V_p$  is faithful  $\mathbb{R}[G_p]$ -module (equivalently, every irreducible representation of  $G_p$  occurs inside  $V_p$ ). The pullback of a coarse vector bundle is coarse, and the pullback of a (module) faithful vector bundle under a *representable* map is (module) faithful.

**Lemma 3.21** *If  $V$  is a faithful representation of a finite group  $G$ , then the open set  $V^{\text{free}} \subseteq V$  on which  $G$  acts freely is open and dense.*

**Proof** The complement of  $V^{\text{free}} \subseteq V$  is the locus  $\bigcup_{1 \neq H \leq G} V^H$ , which is a finite union of proper subspaces. □

**Lemma 3.22** *If  $V$  is a faithful representation of a finite group  $G$ , then every irreducible representation of  $G$  is a direct summand of a tensor power of  $V$ .*

**Proof** This is a classical fact with many known proofs, whose correct attribution is not known to me. By Lemma 3.21, there exists a point  $x \in V^*$  all of whose translates by  $G$  are distinct. By Weierstrass, there exists a polynomial function on  $V^*$  (that is, an element of  $\bigoplus_{i=0}^{\infty} \text{Sym}^i V$ ) which is approximately a bump function supported around  $x$ . The translates of this element under  $G$  are thus linearly independent, so their span is a copy of the regular representation of  $G$  inside  $\bigoplus_{i=0}^{\infty} \text{Sym}^i V$ , which is in turn contained in  $\bigoplus_{i=0}^{\infty} V^{\otimes i}$ . □

It follows from Lemma 3.22 that given a faithful vector bundle  $E$  over a compact orbispace (or, more generally, an orbispace with isotropy groups of bounded order), there exists an  $N < \infty$  such that  $\bigoplus_{i=1}^N E^{\otimes i}$  is module faithful. If  $E$  is a module faithful vector bundle over a compact  $X$  and  $F$  is arbitrary (more generally,  $X$  could be paracompact and  $F$  bounded dimensional), there exists an  $N < \infty$  and an embedding  $F \hookrightarrow E^{\oplus N}$ .

It was shown in [29] that every orbispace satisfying certain mild hypotheses admits a faithful vector bundle. In particular, all compact orbispaces admit faithful vector bundles. In fact, the construction gives somewhat more precise control on these faithful vector bundles, however for us, all we need is the following:

**Theorem 3.23** [29] *Every finite orbi-CW-complex admits a faithful vector bundle.*

Note that the same thus holds for any space homotopy equivalent to a finite orbi-CW-complex (such as a compact orbifold-with-boundary), since homotopy equivalences of orbispaces are representable.

**Corollary 3.24** *Let  $f: X \rightarrow Y$  be a representable smooth map of smooth compact orbifolds. There exists a vector bundle  $E/Y$  such that  $f$  lifts to a smooth embedding of  $X$  into the total space of  $E$ .*

(Recall that a smooth embedding of orbifolds is locally modeled on  $V/G \subseteq W/G$  for an inclusion  $V \subseteq W$  of  $G$ -representations.)

**Proof** Let  $E$  be any module faithful vector bundle over  $Y$ . Choose arbitrarily a connection on  $E$ , and equip  $f^*E$  with the pullback connection. We claim that there exists a section  $s$  of  $f^*E^N$  whose derivative  $ds: TX \rightarrow f^*E^N$  is injective. Indeed, in local coordinates  $X = \mathbb{R}^n/G$  and  $E = (\mathbb{R}^n \times V)/G$ , for some actions of  $G$  on  $\mathbb{R}^n$  and  $V$ , consider the map  $s$  given by a  $G$ -equivariant linear map  $\mathbb{R}^n \rightarrow V^N$ . Since  $V$  contains all irreducible representations of  $G$ , by taking  $N$  large enough we can choose  $\mathbb{R}^n \rightarrow V^N$  to be injective. Thus  $ds$  is injective at zero, hence in a neighborhood; cutting it off we can make it compactly supported. By compactness, we can take the direct sum of finitely many such  $s$  to obtain a section  $s: X \rightarrow f^*E^N$  whose derivative is injective everywhere. Such an  $s$  is a smooth immersion. A smooth immersion may be “separated” by a map from  $X$  — necessarily factoring through  $|X|!$  — to  $\mathbb{R}^M$ , so our desired vector bundle is  $E^N \oplus \underline{\mathbb{R}}^M$ .  $\square$

Recall that an orbifold (resp. orbifold-with-boundary) is locally modeled on  $\mathbb{R}^n/G$  (resp.  $(\mathbb{R}^{n-1} \times \mathbb{R}_{\geq 0})/G$ ), and that it is called effective when the homomorphisms  $G \rightarrow \mathrm{GL}_n(\mathbb{R})$  are *injective*.

**Corollary 3.25** *Every finite orbi-CW-complex is homotopy equivalent to a compact effective orbifold-with-boundary.*

In fact, Corollary 3.25 is equivalent to Theorem 3.23 since every effective orbifold-with-boundary admits a faithful vector bundle, namely its tangent bundle.

**Proof** We proceed by induction on the number of cells. Thus, suppose that  $X$  is a compact effective orbifold-with-boundary and that  $Z = X \cup_{\partial D^k \times \mathbf{B}G} (D^k \times \mathbf{B}G)$  for some representable map  $\partial D^k \times \mathbf{B}G \rightarrow X$ . Let us show that  $Z$  is homotopy equivalent to a compact effective orbifold-with-boundary. The strategy is to realize the cell attachment to  $X$  as a handle attachment.

By Corollary 3.24, after replacing  $X$  with the total space of (the unit disk bundle of) a vector bundle over it (and smoothing its corners), we may assume that our map  $\partial D^k \times \mathbf{B}G \rightarrow X$  is a smooth embedding into  $\partial X$ . By the tubular neighborhood theorem, this smooth embedding is locally modeled on the inclusion of the zero section into the total space of a vector bundle  $\nu$  over  $\partial D^k \times \mathbf{B}G$ . Now we have  $\nu \oplus T(\partial D^k \times \mathbf{B}G) = T\partial X$  over  $\partial D^k \times \mathbf{B}G$ , and identifying the outward normal along  $\partial X$  with the inward normal along  $\partial D^k \times \mathbf{B}G$ , we obtain an identification  $\nu \oplus T(D^k \times \mathbf{B}G) = TX$  over  $\partial D^k \times \mathbf{B}G$ . By Theorem 3.23, there exists a vector bundle  $\eta$  on  $Z$  and an embedding  $TX \hookrightarrow \eta|_X$ . By replacing  $X$  with the total space of  $\eta|_X/TX$ , we may assume that  $TX = \eta|_X$ . We thus have an embedding  $T(D^k \times \mathbf{B}G) \hookrightarrow \eta$  defined over  $\partial D^k \times \mathbf{B}G$ . By further enlarging  $\eta$  (and modifying  $X$  as this requires), we may ensure that this embedding  $T(D^k \times \mathbf{B}G) \hookrightarrow \eta$  extends to all of  $D^k \times \mathbf{B}G$ . The cokernel of this embedding is thus an extension of  $\nu$  to  $D^k \times \mathbf{B}G$ , so we can perform a handle attachment to construct our desired compact effective orbifold-with-boundary. Finally, we should note that in the case  $k = 0$ , we should not take  $\mathbf{B}G$  as this is not effective; rather, we can take the unit ball in any faithful  $G$ -representation modulo  $G$ . □

We will need an analogue of the previous corollary for orbi-CW-pairs. Let us define an *orbifold pair*  $(X, A)$  to consist of an orbifold-with-boundary  $X$  and a codimension-zero suborbifold-with-boundary  $A \subseteq \partial X$ . In this paper, we only ever deal with compact orbifold pairs.

**Corollary 3.26** *Every finite orbi-CW-pair is homotopy equivalent to a compact effective orbifold pair.*

**Proof** Corollary 3.25 implies the result for finite orbi-CW-pairs of the form  $(X, X)$ ; namely, realize  $X$  as a compact orbifold-with-boundary  $Z$  and take  $(Z \times [0, 1], Z)$ . Now given a finite orbi-CW-pair  $(X, A)$ , we begin with an orbifold pair homotopy equivalent to  $(A, A)$ , and we successively attach handles (away from the marked part of the boundary) as in the proof of Corollary 3.25 to make it homotopy equivalent to  $(X, A)$ . □

### 3.9 Stable homotopy categories of orbispaces

We now describe how to “stabilize” the categories  $\text{OrbSpc}_*^f$  and  $\text{RepOrbSpc}_*^f$  to obtain categories of finite orbispectra. The categories of finite “naive orbispectra” are defined by taking the direct limit of  $\text{OrbSpc}_*^f$  and  $\text{RepOrbSpc}_*^f$  under successive

applications of the suspension operation  $\Sigma$  (namely  $\times(I, \partial I)$ ). The formal desuspension  $(X, A)^{-V}$  for any coarse vector bundle  $V$  makes sense as a naive orbispectrum, since any such  $V$  embeds into a trivial vector bundle. We are more interested in the categories  $\text{OrbSp}^f$  and  $\text{RepOrbSp}^f$  of finite “genuine orbispectra”, whose objects take the form  $(X, A)^{-V}$  for any vector bundles  $V$ , with morphisms being a suitable direct limit over passing to Thom spaces of arbitrary vector bundles.

We first discuss naive orbispectra. The suspension operation  $\times(I, \partial I)$  defines an endofunctor  $\Sigma$  of both  $\text{RepOrbSp}_*$  and  $\text{OrbSp}_*$ . The direct limit of successive applications of this endofunctor defines stable homotopy categories

$$(3-32) \quad \text{RepOrbSp}_*[\Sigma^{-1}] := \varinjlim(\text{RepOrbSp}_* \xrightarrow{\Sigma} \text{RepOrbSp}_* \xrightarrow{\Sigma} \dots),$$

$$(3-33) \quad \text{OrbSp}_*[\Sigma^{-1}] := \varinjlim(\text{OrbSp}_* \xrightarrow{\Sigma} \text{OrbSp}_* \xrightarrow{\Sigma} \dots).$$

Concretely, the objects of both these categories are formal symbols  $\Sigma^{-n}(X, A)$  for orbi-CW-pairs  $(X, A)$  and integers  $n \geq 0$ , and the set of morphisms  $\Sigma^{-n}(X, A) \rightarrow \Sigma^{-m}(Y, B)$  is the direct limit over  $k \rightarrow \infty$  of morphisms in  $\text{RepOrbSp}_*$  and  $\text{OrbSp}_*$ , respectively, from  $\Sigma^{k-n}(X, A)$  to  $\Sigma^{k-m}(Y, B)$ , which makes sense for  $k \geq \max(m, n)$ . It follows that  $\Sigma$  defines autoequivalences of  $\text{RepOrbSp}_*[\Sigma^{-1}]$  and  $\text{OrbSp}_*[\Sigma^{-1}]$ , and that there is a natural isomorphism  $\Sigma^{-1}((X, A) \times (I, \partial I)) = (X, A)$  in both these categories. There is a functor  $\text{RepOrbSp}_*[\Sigma^{-1}] \rightarrow \text{OrbSp}_*[\Sigma^{-1}]$ . We can make sense out of symbols  $(X, A)^{-V}$  (here  $(X, A)$  is a compact orbi-CW-pair and  $V$  a coarse vector bundle over  $X$ ) as objects of  $\text{RepOrbSp}_*[\Sigma^{-1}]$  and  $\text{OrbSp}_*[\Sigma^{-1}]$ , namely by embedding  $V \hookrightarrow \mathbb{R}^n$  and taking  $(X, A)^{-V} := \Sigma^{-n}((X, A)^{\mathbb{R}^n/V})$ , which is independent of the choice of embedding  $V \hookrightarrow \mathbb{R}^n$  up to canonical isomorphism.

The category

$$\text{Spc}_*[\Sigma^{-1}] := \varinjlim(\text{Spc}_* \xrightarrow{\Sigma} \text{Spc}_* \xrightarrow{\Sigma} \dots)$$

lies as a full subcategory inside both  $\text{RepOrbSp}_*[\Sigma^{-1}]$  and  $\text{OrbSp}_*[\Sigma^{-1}]$ .

**Lemma 3.27** *The categories  $\text{OrbSp}_*[\Sigma^{-1}]$  and  $\text{RepOrbSp}_*[\Sigma^{-1}]$  are additive.*

**Proof** There is a natural abelian group structure on the morphism space in  $\text{OrbSp}_*$  and  $\text{RepOrbSp}_*$  from  $(X, A) \times (I^2, \partial I^2)$  to  $(Y, B)$ . This gives an enrichment of  $\text{OrbSp}_*[\Sigma^{-1}]$  and  $\text{RepOrbSp}_*[\Sigma^{-1}]$  over abelian groups. It is immediate that finite disjoint unions are finite coproducts. A category enriched over abelian groups and which has finite coproducts is additive. □

The categories  $\text{OrbSpc}_*[\Sigma^{-1}]$  and  $\text{RepOrbSpc}_*[\Sigma^{-1}]$  may be described alternatively as localizations as follows. We consider the ‘‘Grothendieck construction’’

$$(3-34) \quad \text{Groth}(\text{OrbSpc}_* \xrightarrow{\Sigma} \text{OrbSpc}_* \xrightarrow{\Sigma} \dots),$$

namely the category whose objects are formal symbols  $\Sigma^{-n}(X, A)$  and whose morphisms  $\Sigma^{-n}(X, A) \rightarrow \Sigma^{-m}(Y, B)$  are morphisms  $(X, A) \rightarrow \Sigma^{n-m}(Y, B)$  in  $\text{OrbSpc}_*$  for  $n \geq m$  (and there are no morphisms otherwise). There is a class  $A$  of morphisms  $\Sigma^{-n}(\Sigma^{n-m}(X, A)) \rightarrow \Sigma^{-m}(X, A)$  corresponding to the identity map of  $\Sigma^{n-m}(X, A)$  for  $n \geq m$ . It is immediate that this class  $A$  forms a right multiplicative system, a notion whose definition we now recall.

**Definition 3.28** (right multiplicative system) A class of morphisms  $W$  in a category  $C$  is called a *right multiplicative system* if and only if it satisfies the following three axioms:

- $W$  contains all identities and is closed under composition.
- **Right Ore condition** For every pair of solid arrows

$$(3-35) \quad \begin{array}{ccc} A & \dashrightarrow & B \\ \in W \downarrow & & \downarrow \in W \\ C & \longrightarrow & D \end{array}$$

there exist an object  $A$  and dotted arrows such that the diagram commutes.

- **Right cancellability** For every commuting diagram of solid arrows

$$(3-36) \quad \begin{array}{ccc} A & \dashrightarrow & B \\ \in W \downarrow & \nearrow & \downarrow \in W \\ C & \longrightarrow & D \end{array}$$

there exist an object  $A$  and dotted arrows such that the diagram commutes.

Note that  $W$  is *not* required to contain all isomorphisms. This is rather antithetical to the philosophy of category theory, however this generality is significant for us.

For any right multiplicative system  $W$  in a category  $C$ , the localization  $C \rightarrow C[W^{-1}]$  exists provided a certain smallness condition is satisfied. Furthermore, for  $X, Y \in C$ , the set of morphisms  $X \rightarrow Y$  in  $C[W^{-1}]$  admits the following concrete description. Given  $X \in C$ , consider the category  $\{Z \xrightarrow{W} X\}$  whose objects are arrows  $Z \xrightarrow{W} X$  and whose morphisms are morphisms over  $X$ , ie  $\{Z \xrightarrow{W} X\}$  is a full subcategory of

the over-category  $C/X$ . The fact that  $W$  is a right multiplicative system implies that  $\{Z \xrightarrow{W} X\}$  is filtered. Provided each category  $\{Z \xrightarrow{W} X\}$  is essentially small, the localization  $C[W^{-1}]$  exists and the set of morphisms  $X \rightarrow Y$  in  $C[W^{-1}]$  is the direct limit over  $\{Z \xrightarrow{W} X\}$  of the set of morphisms  $Z \rightarrow Y$ .

The functor from the Grothendieck construction (3-34) to  $\text{OrbSpc}_*[\Sigma^{-1}]$  sends  $A$  to isomorphisms, hence factors uniquely through the localization. Using the explicit description of morphisms in the localization by a right multiplicative system, it is immediate that this functor is an equivalence.

We now define the categories of finite *genuine orbispectra*  $\text{OrbSp}^f$  and  $\text{RepOrbSp}^f$ . Let us begin with the categories  $\text{OrbSpcPair}^{f,-\text{Vect}}$  and  $\text{RepOrbSpcPair}^{f,-\text{Vect}}$ , whose objects are  $(X, A)^{-\xi}$ , where  $(X, A)$  is a finite orbi-CW-pair and  $\xi$  is a vector bundle over  $X$ . A morphism in these categories  $(X, A)^{-\xi} \rightarrow (Y, B)^{-\zeta}$  consists of a (representable) map  $f: X \rightarrow Y$ , an embedding  $i: f^*\zeta \hookrightarrow \xi$ , and a section  $s: X \rightarrow \xi/i(f^*\zeta)$  such that  $A \subseteq f^{-1}(B) \cup s^{-1}(\{|\cdot| \geq \varepsilon\})$  for some  $\varepsilon > 0$ —these triples  $(f, i, s): (X, A)^{-\xi} \rightarrow (Y, B)^{-\zeta}$  are considered up to homotopy, namely the equivalence relation of there being such a morphism  $(X \times [0, 1], A \times [0, 1])^{-\xi} \rightarrow (Y, B)^{-\zeta}$ . To compose

$$(X, A)^{-\xi} \xrightarrow{(f,i,s)} (Y, B)^{-\zeta} \xrightarrow{(g,j,t)} (Z, C)^{-\eta}$$

we take  $g \circ f$  and  $j \circ i$ ; now there is an extension

$$(3-37) \quad 0 \rightarrow \zeta/i(\xi) \xrightarrow{j} \eta/j(i(\xi)) \rightarrow \eta/j(\zeta) \rightarrow 0,$$

and choosing a splitting (which is unique up to homotopy) allows us to take  $tf \oplus js$  as our section for the composition. Composition is associative.

We now define categories  $\text{OrbSpc}_*^{f,-\text{Vect}}$  and  $\text{RepOrbSpc}_*^{f,-\text{Vect}}$  by modifying the definition above by declaring that a morphism  $(X, A)^{-\xi} \rightarrow (Y, B)^{-\zeta}$  consists of  $A \subseteq A^+ \subseteq X$  closed and  $U \subseteq X$  open with  $X = U \cup (A^+)^{\circ}$  and a morphism  $(U, U \cap A^+)^{-\xi} \rightarrow (Y, B)^{-\zeta}$  in  $\text{OrbSpcPair}^{f,-\text{Vect}}$  or  $\text{RepOrbSpcPair}^{f,-\text{Vect}}$ ; these are considered modulo homotopy as usual. Composition of

$$(3-38) \quad (X, A)^{-\xi} \xrightarrow{(A^+,U,f,i,s)} (Y, B)^{-\zeta} \xrightarrow{(B^+,V,g,j,t)} (Z, C)^{-\eta}$$

is given by  $(A^+ \cup f^{-1}(B^+), f^{-1}(V), g \circ f, j \circ i, tf \oplus js)$  as before. The proof of Proposition 3.15 applies without modification to show that:

**Proposition 3.29** (excision) *The functors*

$$(3-39) \quad \text{OrbSpcPair}^{f,-\text{Vect}} \rightarrow \text{OrbSpc}_*^{f,-\text{Vect}},$$

$$(3-40) \quad \text{RepOrbSpcPair}^{f,-\text{Vect}} \rightarrow \text{RepOrbSpc}_*^{f,-\text{Vect}},$$

are localizations at the collection  $W$  of morphisms of the form  $(P, P \cap Q)^{-\xi} \rightarrow (X, Q)^{-\xi}$ , where  $X = P \cup Q$  is a cover by subcomplexes and  $\xi$  is a vector bundle over  $X$ . □

We now localize  $\text{RepOrbSpc}_*^{f,-\text{Vect}}$  and  $\text{OrbSpc}_*^{f,-\text{Vect}}$  at the class of morphisms  $S$  given by the images of the isomorphism classes in  $\text{RepOrbSpcPair}^{f,-\text{Vect}}$  of the tautological morphisms  $((X, A)^\xi)^{-(\xi \oplus \xi)} \rightarrow (X, A)^{-\xi}$ . The following deserves emphasis: the objects of  $\text{RepOrbSpc}_*^{f,-\text{Vect}}$  and  $\text{OrbSpc}_*^{f,-\text{Vect}}$  remain symbols  $(X, A)^{-\xi}$ , and while two different symbols  $(X, A)^{-\xi}$  and  $(X', A')^{-\xi'}$  may be isomorphic in the localizations  $\text{RepOrbSpc}_*^{f,-\text{Vect}}$  or  $\text{OrbSpc}_*^{f,-\text{Vect}}$ , they need not be isomorphic in  $\text{RepOrbSpcPair}^{f,-\text{Vect}}$ , and hence are regarded as *completely different* when it comes to the question of whether a morphism is or is not in  $S$ .

**Lemma 3.30** *The morphisms  $S$  form a right multiplicative system in the categories  $\text{RepOrbSpc}_*^{f,-\text{Vect}}$  and  $\text{OrbSpc}_*^{f,-\text{Vect}}$ .*

**Proof** Closedness under composition holds because any vector bundle on the total space of a vector bundle is pulled back from the base, so a Thom space of a Thom space is a Thom space. (Note that isomorphisms in  $\text{RepOrbSpc}_*^{f,-\text{Vect}}$  and  $\text{OrbSpc}_*^{f,-\text{Vect}}$  need not be in  $S$ , and that we *have not* shown that  $S$  is not closed under composing with such isomorphisms!)

We verify the right Ore condition. When the morphism  $C \rightarrow D$  in  $\text{OrbSpc}_*^{f,-\text{Vect}}$  comes from  $\text{OrbSpcPair}^{f,-\text{Vect}}$  (and similarly with “Rep” prefixes), we can simply pull back the bundle involved in  $B \rightarrow D$ :

$$(3-41) \quad \begin{array}{ccc} ((X, A)^{f^*\eta})^{-(\xi \oplus f^*\eta)} & \dashrightarrow & ((Y, B)^\eta)^{-(\xi \oplus \eta)} \\ \in S \downarrow & & \downarrow \in S \\ (X, A)^{-\xi} & \longrightarrow & (Y, B)^{-\xi} \end{array}$$

In the general case, the bottom row becomes

$$(X, A)^{-\xi} \rightarrow (X, A^+)^{-\xi} \leftarrow (U, U \cap A^+)^{-\xi} \rightarrow (Y, B)^{-\xi}.$$

Now we may pull back  $\eta$  to  $U$ , but not to  $X$ . Instead, we appeal to Theorem 3.23 (enough vector bundles) to embed the pullback of  $\eta$  to  $U$  into the restriction of a vector bundle  $\tau$  on  $X$ . We thus obtain the following diagram:

$$\begin{array}{ccccc}
 ((X, A)^\tau)^{-(\xi \oplus \tau)} & \rightarrow & ((X, A^+)^\tau)^{-(\xi \oplus \tau)} & \xleftarrow{\in W} & ((U, U \cap A^+)^\tau)^{-(\xi \oplus \tau)} \\
 \downarrow \in S & & \downarrow \in S & & \downarrow \in S \\
 (3-42) & & & & ((U, U \cap A^+)^{f^* \eta})^{-(\xi \oplus f^* \eta)} \rightarrow ((Y, B)^\eta)^{-(\zeta \oplus \eta)} \\
 & & & & \downarrow \in S \\
 (X, A)^{-\xi} & \longrightarrow & (X, A^+)^{-\xi} & \xleftarrow{\in W} & (U, U \cap A^+)^{-\xi} \longrightarrow (Y, B)^{-\zeta}
 \end{array}$$

The desired result follows.

We verify right cancellability. It suffices to show that given maps  $C \rightarrow B \xrightarrow{\in S} D$ , applying the pullback procedure above to  $C \rightarrow D \xleftarrow{\in S} B$  results in  $C \xleftarrow{\in S} A \rightarrow B$  for which  $A \rightarrow B$  and  $A \rightarrow C \rightarrow B$  coincide (in this way, the dotted arrows in (3-36) that we produce depend only on the maps  $C \rightarrow D \xleftarrow{\in S} B$ ). As above, we first consider the situation of a morphism  $C \rightarrow D$  coming from  $\text{OrbSpcPair}^{f, -\text{Vect}}$  (or similarly, from  $\text{RepOrbSpcPair}^{f, -\text{Vect}}$ ), ie we consider (3-41). Even in this setting, the desired commutativity is not obvious and requires the following calculation. We reproduce the relevant diagram, rewriting it in a more convenient way:

$$\begin{array}{ccc}
 ((X, A)^{f^* \eta})^{-(f^* \zeta \oplus f^* \eta \oplus \xi \oplus f^* \eta)} & \longrightarrow & ((Y, B)^\eta)^{-(\zeta \oplus \eta)} \\
 \downarrow & \nearrow & \downarrow \\
 (X, A)^{-(f^* \zeta \oplus f^* \eta \oplus \xi)} & \longrightarrow & (Y, B)^{-\zeta}
 \end{array}
 \tag{3-43}$$

Let the diagonal map  $(X, A)^{-\xi} \rightarrow ((Y, B)^\eta)^{-(\zeta \oplus \eta)}$  be given by the maps  $f: X \rightarrow Y$ ,  $g: X \rightarrow f^* \eta$ , the obvious inclusion  $f^*(\zeta \oplus \eta) \hookrightarrow f^* \zeta \oplus f^* \eta \oplus \xi$ , and  $s: X \rightarrow \xi$ . Now we have two maps  $((X, A)^{f^* \eta})^{-(f^* \zeta \oplus f^* \eta \oplus \xi \oplus f^* \eta)} \rightarrow ((Y, B)^\eta)^{-(\zeta \oplus \eta)}$  which we wish to show are homotopic. The top horizontal arrow is given by  $f^\eta: X^{f^* \eta} \rightarrow Y^\eta$ , the inclusion  $f^* \zeta \oplus f^* \eta \hookrightarrow f^* \zeta \oplus f^* \eta \oplus \xi \oplus f^* \eta$ , where  $f^* \eta$  goes to the last copy, and the section  $X^{f^* \eta} \rightarrow X \xrightarrow{s \oplus g} \xi \oplus f^* \eta$ . The composition of the left vertical arrow and the diagonal arrow is given by  $(f \circ \pi_X, g): X^{f^* \eta} \rightarrow Y^\eta$ , the inclusion  $f^* \zeta \oplus f^* \eta \hookrightarrow f^* \zeta \oplus f^* \eta \oplus \xi \oplus f^* \eta$ , where  $f^* \eta$  goes to the first copy, and  $s \oplus \pi_{f^* \eta}: X^{f^* \eta} \rightarrow \xi \oplus f^* \eta$ . These maps are evidently not the same, but they are homotopic as follows. We first apply the obvious linear homotopy from one inclusion  $f^* \zeta \oplus f^* \eta \hookrightarrow f^* \zeta \oplus f^* \eta \oplus \xi \oplus f^* \eta$  to the other, noting that the induced action on the cokernel, naturally identified in both cases with  $f^* \eta$ , is multiplication by  $-1$ . Now our two maps coincide except that we



need to transform  $(g, \text{id}_{f^*\eta})$  into  $(\text{id}_{f^*\eta}, -g)$  (note the sign picked up from the first homotopy), which we can do using rotation matrices for  $\theta \in [0, \pi/2]$ .

Finally, we should show right cancellability in the case of general maps  $C \rightarrow D$ ; we use the same strategy as above. Note that a pullback along  $C \rightarrow D$  involves a choice of vector bundle  $\xi$  over  $C$  (let us call this a  $\xi$ -pullback), and that a choice of embedding  $\xi \hookrightarrow \zeta$  determines a map from  $\xi$ -pullbacks to  $\zeta$ -pullbacks (“stabilization”). Now it is evident from the definition that given a  $\xi$ -pullback and a  $\xi'$ -pullback, there exist embeddings  $\xi \hookrightarrow \zeta$  and  $\xi' \hookrightarrow \zeta$  such that the induced  $\zeta$ -pullbacks coincide. Note that this includes the assertion that pullbacks induced by homotopic maps are equivalent, which is shown by considering the pullback along the homotopy itself. It now suffices to show the same commutativity as before, namely that  $A \rightarrow C \rightarrow B$  and  $A \rightarrow B$  agree. To see this, note that the present situation is that of the solid arrows in (3-42) plus a single additional diagonal arrow  $(U, U \cap A^+)^{-\xi} \rightarrow ((Y, B)^\eta)^{-(\zeta \oplus \eta)}$  in the lower rightmost square. The resulting dotted arrows in that square commute by the reasoning in the previous paragraph, which combined with the commutativity of the rest of the diagram imply that everything commutes. □

The right multiplicative system  $S$  also satisfies the smallness condition needed to localize: the category of  $S$ -morphisms over  $(X, A)^{-\xi}$  has as its objects all vector bundles over  $X$ , and the isomorphism classes of these form a set.

By Lemma 3.30 and the smallness condition, the localizations of  $\text{RepOrbSpc}_*^{f, -\text{Vect}}$  and  $\text{OrbSpc}_*^{f, -\text{Vect}}$  at  $S$  exist, and we denote these localizations by  $\text{RepOrbSp}^f$  and  $\text{OrbSp}^f$ , respectively. Morphisms  $(X, A)^{-\xi} \rightarrow (Y, B)^{-\zeta}$  in  $\text{RepOrbSp}^f$  and  $\text{OrbSp}^f$  are thus described as the direct limit over vector bundles  $\eta$  over  $X$  of morphisms  $((X, A)^\eta)^{-(\eta \oplus \xi)} \rightarrow (Y, B)^{-\zeta}$  in  $\text{RepOrbSpc}_*^{f, -\text{Vect}}$  and  $\text{OrbSpc}_*^{f, -\text{Vect}}$ , respectively. Now it makes sense to write  $(X, A)^V$  for an object of  $\text{RepOrbSp}^f$  for any finite orbifold CW-pair  $(X, A)$  and any stable vector bundle  $V$  over  $X$ , since a stable isomorphism  $E - F = E' - F'$  induces an isomorphism  $((X, A)^E)^{-F} = ((X, A)^{E'})^{-F'}$  in  $\text{RepOrbSp}^f$ .

There are functors  $\text{RepOrbSpc}_*^f[\Sigma^{-1}] \rightarrow \text{RepOrbSp}^f$  and  $\text{OrbSpc}_*^f[\Sigma^{-1}] \rightarrow \text{OrbSp}^f$ . To construct them, note that  $\Sigma^{-n}(X, A) \mapsto (X, A)^{-\mathbb{R}^n}$  defines functors out of the relevant Grothendieck constructions, which send  $A$  to isomorphisms.

**Lemma 3.31** *The categories  $\text{RepOrbSp}^f$  and  $\text{OrbSp}^f$  are additive.*

**Proof** Same as Lemma 3.27. □

For any covering space  $(X', A') \rightarrow (X, A)$  (meaning  $X' \rightarrow X$  is a covering space and  $A' = A \times_X X'$ ), there is an induced map  $(X, A) \rightarrow (X', A')$  in  $\text{RepOrbSp}^f$ . It is defined by embedding  $X'$  into the total space of a vector bundle over  $X$  — which exists by enough vector bundles Theorem 3.23 — and taking the usual collapse map.

There is a functor  $\text{RepOrbSp}^f \rightarrow \text{OrbSp}^f$ , and the category of finite spectra  $\text{Sp}^f$  is a full subcategory of both.

There is a classifying space functor  $\text{OrbSp}^f \rightarrow \text{Sp}$ , defined as follows. We first define the corresponding functor  $\text{OrbSpcPair}^{f, -\text{Vect}} \rightarrow \text{Sp}$ , which sends  $(X, A)^{-V}$  to  $(\tilde{X}, \tilde{A})^{-V} \in \text{Sp}$ ; concretely,  $(\tilde{X}, \tilde{A})^{-V}$  is the direct limit over finite subcomplexes  $(\tilde{X}_0, \tilde{A}_0)$  and embeddings  $V|_{\tilde{X}_0} \hookrightarrow \mathbb{R}^N$  of  $\Sigma^{-N}((\tilde{X}_0, \tilde{A}_0)^{\mathbb{R}^N/V})$ . Given a map  $(X, A)^{-V} \rightarrow (Y, B)^{-W}$  in  $\text{OrbSpcPair}^{f, -\text{Vect}}$  consisting of a map  $f: X \rightarrow Y$ , an inclusion  $f^*W \hookrightarrow V$  and a section  $s: X \rightarrow V/f^*W$ , we define a map  $(\tilde{X}, \tilde{A})^{-V} \rightarrow (\tilde{Y}, \tilde{B})^{-W}$  in  $\text{Sp}$  as follows. Choose classifying spaces  $\tilde{A} \subseteq \tilde{X}$  and  $\tilde{B} \subseteq \tilde{Y}$  and the map  $\tilde{f}: \tilde{X} \rightarrow \tilde{Y}$  fitting into a strictly commutative diagram with  $f$  such that  $\tilde{f}(f^{-1}(B)) \subseteq \tilde{B}$ ; this can be done by induction on the cells of  $(X, A)$  and  $(Y, B)$ . Now the map  $\tilde{f}: \tilde{X} \rightarrow \tilde{Y}$ , the pullback inclusion  $\tilde{f}^*W \hookrightarrow V$  and the pullback of  $s$  define a map  $(\tilde{X}, \tilde{A})^{-V} \rightarrow (\tilde{Y}, \tilde{B})^{-W}$  in  $\text{SpcPair}^{-\text{Vect}}$ , hence in  $\text{Sp}$ ; concretely, the induced map in  $\text{Sp}$  is given, over a given finite subcomplex of  $(\tilde{X}, \tilde{A})$ , by taking  $N$  large enough that the map  $f^*W \hookrightarrow V \hookrightarrow \mathbb{R}^N$  is homotopic to the pullback of  $W \hookrightarrow \mathbb{R}^N$ , so  $f^*(\mathbb{R}^N/W) = (\mathbb{R}^N/V) \oplus V/f^*W$ . So we may use the identity on the first factor and the section  $s$  on the second factor to define a map  $(\tilde{X}, \tilde{A})^{\mathbb{R}^N/V} \rightarrow (\tilde{Y}, \tilde{B})^{\mathbb{R}^N/W}$  (strictly speaking, only on arbitrary finite subcomplexes thereof), which we desuspend by  $N$ . It is immediate to check that morphisms  $W$  are sent to isomorphisms, and morphisms  $S$  are also by inspection. We therefore have a classifying space functor  $\text{OrbSp}^f \rightarrow \text{Sp}$ .

There is a symmetric monoidal “smash product”  $\wedge$  on  $\text{RepOrbSp}^f$  and  $\text{OrbSp}^f$  defined as follows. The product  $(X, A)^{-\xi} \times (Y, B)^{-\zeta} := (X \times Y, (A \times Y) \cup (X \times B))^{-\xi-\zeta}$  is a symmetric monoidal structure on  $\text{RepOrbSpcPair}^{f, -\text{Vect}}$  and  $\text{OrbSpcPair}^{f, -\text{Vect}}$ . To see that it descends to  $\text{RepOrbSp}^f$  and  $\text{OrbSp}^f$ , it suffices to show that a morphism in  $W$  or  $S$  times a fixed  $(Y, B)^{-\zeta}$  again lies in  $W$  or  $S$ . For  $S$  this is obvious, and for  $W$  this follows by inspection exactly as in the construction of the smash product on  $\text{RepOrbSpc}_*^f$  and  $\text{OrbSpc}_*^f$ .

There is a natural isomorphism  $(Z \wedge W)^\sim = \tilde{Z} \wedge \tilde{W}$  for  $Z, W \in \text{OrbSp}^f$ ; to define this, it suffices to define it on the corresponding functors out of the product

$\text{OrbSpcPair}^{f,-\text{Vect}} \times \text{OrbSpcPair}^{f,-\text{Vect}}$ , where it is defined in the same way as the corresponding isomorphisms for  $Z, W \in \text{OrbSpc}_*$ .

### 3.10 Exact triangles

A triple of morphisms in  $\text{RepOrbSp}^f$  is called a cofiber sequence if and only if it is isomorphic to

$$(3-44) \quad (Y, B)^{-\xi} \rightarrow (X, A)^{-\xi} \rightarrow (X, A \cup_B Y)^{-\xi}$$

for an orbi-CW-complex  $X$  with two subcomplexes  $A, Y \subseteq X$  and  $B := A \cap Y$  and a vector bundle  $\xi$  over  $X$ ; compare (3-25). We now show that every morphism in  $\text{RepOrbSp}^f$  has a cofiber, from which it follows that every morphism can be extended to a bi-infinite cofiber sequence by desuspending the Puppe sequence.

**Proposition 3.32** *Every morphism in  $\text{RepOrbSp}^f$  is isomorphic to one of the form  $(Y, B)^{-\xi} \rightarrow (X, A)^{-\xi}$  for  $X$  an orbi-CW-complex carrying a vector bundle  $\xi$  and  $A, Y \subseteq X$  subcomplexes with  $B = A \cap Y$ .*

**Proof** Since the localization  $\text{RepOrbSpc}_*^{f,-\text{Vect}} \xrightarrow{S^{-1}} \text{RepOrbSp}^f$  is by a right multiplicative system, every morphism in the target is isomorphic to one coming from the source. In other words, every morphism in  $\text{RepOrbSp}^f$  is (up to isomorphism) a formal composition  $(X, A)^{-\xi} \rightarrow (X, A^+)^{-\xi} \leftarrow (U, U \cap A^+)^{-\xi} \xrightarrow{f} (Y, B)^{-\xi}$ . As in the proof of Proposition 3.18, we may assume that  $U, A^+ \subseteq X$  are subcomplexes covering  $X$ . Form the gluing  $X \cup_U (U \times [0, 1]) \cup_U Y$ , and find, using enough vector bundles (Theorem 3.23), a vector bundle  $\tau$  over it together with embeddings  $\xi \hookrightarrow \tau|_X$  and  $\zeta \hookrightarrow \tau|_Y$ . By replacing  $\tau$  with  $\tau \oplus \tau$ , we may ensure that the composition  $f^*\zeta \hookrightarrow \xi|_U \hookrightarrow \tau|_U$  is homotopic to the pullback under  $f$  of the embedding  $\zeta \hookrightarrow \tau|_Y$ . We thus obtain a commutative diagram

$$(3-45) \quad \begin{array}{ccccccc} ((X, A)^{\tau|_X/\xi})^{-\tau|_X} & \rightarrow & ((X, A^+)^{\tau|_X/\xi})^{-\tau|_X} & \leftarrow & ((U, U \cap A^+)^{\tau|_U/\xi|_U})^{-\tau|_U} & \rightarrow & ((Y, B)^{\tau|_Y/\zeta})^{-\tau|_Y} \\ \downarrow \epsilon_S & & \downarrow \epsilon_S & & \downarrow \epsilon_S & & \downarrow \epsilon_S \\ (X, A)^{-\xi} & \longrightarrow & (X, A^+)^{-\xi} & \longleftarrow & (U, U \cap A^+)^{-\xi} & \longrightarrow & (Y, B)^{-\xi} \end{array}$$

Now the top row is just the desuspension by  $\tau$  of maps  $(X, A)^{\tau|_X/\xi} \rightarrow (X, A^+)^{\tau|_X/\xi} \leftarrow (U, U \cap A^+)^{\tau|_U/\xi|_U} \rightarrow (Y, B)^{\tau|_Y/\zeta}$ , all of which respect the vector bundle  $\tau$  being desuspended by. Now take this as (3-26) and apply the construction of that proof to it, and then desuspend by  $\tau$  (which we crucially must note does indeed make sense on the result). □

### 3.11 Stabilizing over $R(*)$

Let us now give an alternative definition of  $\text{RepOrbSp}^f$  (but not of  $\text{OrbSp}^f$ ). Morally, we would like to simply say that

$$(3-46) \quad \text{RepOrbSp}^f = \varinjlim_{\text{Vect}(R(*)}) \text{RepOrbSp},$$

in the sense that every orbi-CW-complex  $X$  admits a unique up to contractible choice representable map to  $R(*)$ , so vector bundles on  $R(*)$  act by endofunctors on  $\text{RepOrbSp}$  by pulling back and passing to Thom spaces. There is a problem with taking (3-46) literally: there are not enough vector bundles on  $R(*)$ , so instead we will filter  $R(*)$  by subcomplexes. Here are the details.

For  $N \geq 1$ , let  $R(*)_N$  denote the image of  $* \in \text{OrbSpc}_N$  under the right adjoint to  $\text{RepOrbSpc}_N \rightarrow \text{OrbSpc}_N$  (which exists by the same argument as in Proposition 3.12), where the subscript  $N$  indicates restricting to orbi-CW-complexes with isotropy groups of order  $\leq N$ . There are representable maps  $R(*)_N \rightarrow R(*)_M$  for  $N \leq M$  by abstract nonsense (the functor  $\text{RepOrbSpc}_N \rightarrow \text{RepOrbSpc}_M$  induces a map between their terminal objects), and the infinite mapping cylinder of  $R(*)_1 \rightarrow R(*)_2 \rightarrow R(*)_3 \rightarrow \dots$  is  $R(*)$ . Concretely,  $R(*)_N$  is given by (3-16) restricted to groups of order  $\leq N$ .

Fix orbi-CW-complexes  $R(*)_N$  and cellular maps  $R(*)_N \rightarrow R(*)_{N+1}$ , and let  $R(*)$  denote their infinite mapping cylinder. Let  $R(*)_{N,k}$  denote the  $k$ -skeleton of  $R(*)_N$ . Note that, whereas  $R(*)_N$  has an intrinsic functorial description,  $R(*)_{N,k}$  does not: it depends on the chosen orbi-CW-complex realization of  $R(*)_N$ . Concretely, we may (but are not obliged to) take  $R(*)_{N,k}$  to be the subcomplex of (3-16) spanned by groups of order  $\leq N$  and simplices of dimension  $\leq k$ . Now every map  $\partial D^r \times \mathbf{BG} \rightarrow R(*)_{N,k}$  extends to  $D^r \times \mathbf{BG}$  provided  $r \leq k$  and  $|G| \leq N$ .

Now suppose  $X$  is an orbi-CW-complex of dimension  $\leq k$  with isotropy groups of order  $\leq N$ . Then there exists a representable map  $X \rightarrow R(*)_{N,k+2}$ , any two such maps are homotopic, and any two homotopies are homotopic rel endpoints. In particular, for every vector bundle  $\xi$  over  $R(*)_{N,k+2}$ , we obtain a vector bundle  $\xi_X$  which is well-defined up to unique homotopy class of isomorphism. Moreover, for any representable map  $X \rightarrow Y$ , the pullback of  $\xi_Y$  is isomorphic to  $\xi_X$  by an isomorphism which is well-defined up to homotopy, and this rule is compatible with composition  $X \rightarrow Y \rightarrow Z$ .

Now let  $\text{RepOrbSpcPair}_{N,k} \subseteq \text{RepOrbSpcPair}$  denote the full subcategory spanned by those orbi-CW-pairs  $(X, A)$  for which  $X$  (though not necessarily  $A$ ) is homotopy

equivalent to an orbi-CW-complex of dimension  $\leq k$  with isotropy groups of size  $\leq N$ . Given any vector bundle  $\xi$  over  $R(*)_{N,k+2}$ , suspension by the pullback of  $\xi$  defines a functor from  $\text{RepOrbSpcPair}_{N,k}$  to itself. Let  $\text{Vect}^2(R(*)_{N,k})$  denote the 2-category whose objects are vector bundles over  $R(*)_{N,k}$ , whose morphisms are inclusions  $V \hookrightarrow V'$ , and whose 2-morphisms are homotopy classes of paths in  $\text{Emb}(V, V')$ . We may consider the direct limit

$$(3-47) \quad \varinjlim_{\text{Vect}^2(R(*)_{N,k+2})} \text{RepOrbSpcPair}_{N,k},$$

where to an inclusion of vector bundles  $\xi \hookrightarrow \xi'$  on  $R(*)_{N,k+2}$  we associate the endofunctor of  $\text{RepOrbSpcPair}_{N,k}$  given by suspending by the pullback of  $\xi'/\xi$ . We may also define (3-47) more concretely (without discussing direct limits of categories over filtered 2-categories): its objects are triples  $(X, A, \xi)$ , where  $(X, A) \in \text{RepOrbSpcPair}_{N,k}$  and  $\xi$  is a vector bundle on  $R(*)_{N,k+2}$ , and the set of morphisms  $(X, A, \xi) \rightarrow (Y, B, \zeta)$  is the direct limit over  $\eta \in \text{Vect}(R(*)_{N,k+2})$  of the set of pairs of embeddings  $\xi \hookrightarrow \eta \hookrightarrow \zeta$  and maps  $(X, A)^{(\eta/\xi)X} \rightarrow (Y, B)^{(\eta/\zeta)Y}$ , modulo simultaneous homotopy of the embeddings and the map.

Now note that increasing  $N$  and  $k$  induces a full faithful inclusion of categories (3-47), since restriction of vector bundles between these subcomplexes of  $R(*)$  is cofinal by enough vector bundles Theorem 3.23 (or, rather, the stronger version [29, Theorem 1.1], which applies since  $R(*)_{N,k+2}$  has bounded dimension and bounded isotropy groups). We therefore obtain a category

$$(3-48) \quad \varinjlim_{N,k} \varinjlim_{\text{Vect}^2(R(*)_{N,k+2})} \text{RepOrbSpcPair}_{N,k}.$$

Restricting to the full subcategory spanned by finite orbi-CW-pairs, ie replacing  $\text{RepOrbSpcPair}_{N,k}$  with  $\text{RepOrbSpcPair}_{N,k}^f$ , we obtain a natural functor to  $\text{RepOrbSp}^f$ , namely the map given by sending the object  $(X, A)$  in the  $\eta$ -term of the direct limit to  $(X, A)^{-\eta X}$  (with the obvious action on morphisms); this is a map out of each copy of  $\text{RepOrbSpcPair}_{N,k}^f$  and descends by the natural coherences.

**Proposition 3.33** *The functor*

$$(3-49) \quad \varinjlim_{N,k} \varinjlim_{\text{Vect}^2(R(*)_{N,k+2})} \text{RepOrbSpcPair}_{N,k}^f \rightarrow \text{RepOrbSp}^f$$

is the localization at the morphisms  $(P, P \cap Q)^{-\eta P} \rightarrow (X, Q)^{-\eta X}$  for  $X = P \cup Q$  and  $\eta$  a vector bundle on  $R(*)_{N,k+2}$ .

**Proof** The morphisms  $(P, P \cap Q)^{-\eta} \rightarrow (X, Q)^{-\eta}$  for  $\eta$  any vector bundle on  $X$  (not necessarily pulled back from  $R(*)_{N,k+2}$ ) are sent to isomorphisms by Proposition 3.29.

First, we note that in the definition of  $\text{RepOrbSp}^f$  as the double localization

$$(3-50) \quad \text{RepOrbSpPair}^{f,-\text{Vect}} \xrightarrow{W^{-1}} \text{RepOrbSpC}_*^{f,-\text{Vect}} \xrightarrow{S^{-1}} \text{RepOrbSp}^f,$$

ie first localizing at the class  $W$  of morphisms  $(P, P \cap Q)^{-\xi} \rightarrow (X, Q)^{-\xi}$  and then at the class  $S$  of morphisms  $((X, A)^V)^{-V-\xi} \rightarrow (X, A)^{-\xi}$ , we could instead localize in the reverse order. Indeed, given that the localization of  $\text{RepOrbSpPair}^{f,-\text{Vect}}$  at  $W \sqcup S$  exists, it suffices to argue that its localization at  $S$  exists. In fact,  $S$  forms a right multiplicative system in  $\text{RepOrbSpPair}^{f,-\text{Vect}}$  — this “easier” variant of Lemma 3.30 was the first step in its proof, in fact. Thus the localization  $\text{RepOrbSpPair}^{f,-\text{Vect}}[S^{-1}]$  exists, and morphisms  $(X, A)^{-\xi} \rightarrow (Y, B)^{-\zeta}$  in it are the direct limit over  $\eta/X$  of morphisms  $((X, A)^\eta)^{-\eta-\xi} \rightarrow (Y, B)^{-\zeta}$  in  $\text{RepOrbSpPair}^{f,-\text{Vect}}$ .

Now it suffices to show that there is a natural equivalence

$$(3-51) \quad \varinjlim_{N,k} \varinjlim_{\text{Vect}^2(R(*)_{N,k+2})} \text{RepOrbSpPair}_{N,k}^f \rightarrow \text{RepOrbSpPair}^{f,-\text{Vect}}[S^{-1}].$$

First, let us describe the functor: the copy of  $\text{RepOrbSpPair}_{N,k}^f$  over the object  $\eta \in \text{Vect}^2(R(*)_{N,k+2})$  maps to  $\text{RepOrbSpPair}^{f,-\text{Vect}}[S^{-1}]$  as  $(X, A) \mapsto (X, A)^{-\eta_X}$ . This functor is obviously essentially surjective, since  $(X, A)^{-\xi}$  in the target is isomorphic to  $((X, A)^{\eta_X/\xi})^{-\eta_X}$  for any embedding  $\xi \hookrightarrow \eta_X$ . It thus remains to show that (3-51) is fully faithful.

In both the source and target of (3-51), the morphisms sets are expressed as direct limits. The set of morphisms  $(X, A)^{-\eta_X} \rightarrow (Y, B)^{-\eta_Y}$  in the domain of (3-51) (where  $(X, A), (Y, B) \in \text{RepOrbSpPair}_{N,k}^f$  and  $\eta \in \text{Vect}^2(R(*)_{N,k+2})$ ) is the direct limit over  $\tau \in \text{Vect}(R(*)_{N,k+2})$  of the set of representable morphisms  $(X, A)^{\tau_X} \rightarrow (Y, B)^{\tau_Y}$ . The set of morphisms between their images under (3-51) is the direct limit over vector bundles  $E$  over  $X$  of tuples consisting of a representable map  $f$  from the total space of  $E$  to  $Y$ , an embedding  $f^*\eta_Y \hookrightarrow \eta_X \oplus E$  and a section of  $(\eta_X \oplus E)/i(f^*\eta_Y)$  such that the “relative part” of  $(X, A)^E$  is contained in  $f^{-1}(B) \cup s^{-1}(\{|\cdot| \geq \varepsilon\})$ . Since  $f$  is representable, there is a natural identification  $f^*\eta_Y = \eta_X$ , which gives a canonical choice of embedding  $f^*\eta_Y \hookrightarrow \eta_X \oplus E$ , which need not coincide with the embedding which is chosen as part of the data. However, for the purposes of calculating the direct limit over  $E$ , we may assume that the chosen embedding  $f^*\eta_Y \hookrightarrow \eta_X \oplus E$  is the canonical one: indeed, given any such embedding, passing to an appropriate

$E' \supseteq E$  makes it homotopic to the canonical one, and similarly any homotopy from the canonical embedding to itself can be made nullhomotopic rel endpoints by enlarging  $E$ . Hence the set of morphisms in the target of (3-51) is the direct limit over vector bundles  $E$  over  $X$  of tuples consisting of a representable map  $f$  from the total space of  $E$  to  $Y$  and a section of  $E$  such that the relative part of  $(X, A)^E$  is contained in  $f^{-1}(B) \cup s^{-1}(\{|\cdot| \geq \varepsilon\})$ . By cofinality, we may instead declare that  $E = \tau_X$  and take the direct limit over  $\tau \in \text{Vect}(R(*)_{N,k+2})$  of the set of maps  $(X, A)^{\tau_X} \rightarrow (Y, B)^{\tau_Y}$  in  $\text{RepOrbSpcPair}_{N,k}^f$ , since  $\tau_X = f^* \tau_Y$  canonically for any representable map  $f$ .  $\square$

Given the description of  $\text{RepOrbSp}^f$  as a direct limit over suspension by vector bundles pulled back from  $R(*)$ , it is natural to make the following conjecture, parallel to Conjecture 3.14.

**Conjecture 3.34** The category  $\text{RepOrbSp}^f$  is a generating full subcategory of the category of parametrized spectra over  $R(*)$ .

If Conjecture 3.34 is valid, it is natural then to ask whether fiberwise Spanier–Whitehead duality makes sense and, if it does, how it is related to the duality involution from Theorem 1.3, which we prove immediately below.

### 3.12 Duality

We now define the contravariant involution  $D: \text{RepOrbSp}^f \rightarrow (\text{RepOrbSp}^f)^{\text{op}}$  as stated in Theorem 1.3.

**Proof of Theorem 1.3** To begin, we define  $D: \text{RepOrbSpcPair}^f \rightarrow (\text{RepOrbSp}^f)^{\text{op}}$ . By Corollary 3.26, we may regard  $\text{RepOrbSpcPair}^f$  as the category of compact orbifold pairs (and morphisms thereof). For any compact orbifold pair  $(X, A)$ , we set

$$(3-52) \quad D(X, A) := (X, \partial X - A^\circ)^{-TX}.$$

The functoriality of  $D$  under maps of orbifold pairs  $(X, A) \rightarrow (Y, B)$  is defined as follows. First, for any vector bundle  $E$  over  $Y$ , denote by  $(Y^E, B^E)$  the pair consisting of the total spaces of the unit disk bundles of  $E$  over  $Y$  and  $B$ . Obviously  $(Y^E, B^E) \rightarrow (Y, B)$  is an isomorphism in  $\text{RepOrbSpcPair}^f$ , and there is also a natural identification  $D(Y^E, B^E) = D(Y, B)$  — the effect on duals of passing from  $(Y, B)$  to  $(Y^E, B^E)$  is to suspend and desuspend by  $E$ . Now, choose  $E$  so that our map  $X \rightarrow Y$  lifts to a smooth embedding  $X \rightarrow Y^E$ , meeting the boundary of  $Y^E$  transversely precisely in  $A$ . There is

now an obvious collapse map  $(Y^E, \partial Y^E - (B^E)^\circ) \dashrightarrow (X, \partial X - A^\circ)^{TY^E/TX}$ , which is independent up to homotopy of the choice of lift of  $X \rightarrow Y$  to  $X \rightarrow Y^E$ , and this collapse map is our desired map  $D(Y, B) = D(Y^E, B^E) \rightarrow D(X, A)$ . By embedding any two choices of  $E$  into a third, we see that the map  $D(Y, B) \rightarrow D(X, A)$  thus defined is independent of the choice of  $E$ . Making the same construction in a family over  $[0, 1]$  shows that it is invariant under homotopy. One also checks that this recipe is compatible with composition, and hence defines a functor  $D: \text{RepOrbSpcPair}^f \rightarrow (\text{RepOrbSp}^f)^{\text{op}}$ .

To descend this functor to  $D: \text{RepOrbSpc}_*^f \rightarrow (\text{RepOrbSp}^f)^{\text{op}}$ , by Proposition 3.15 it suffices to check that  $D$  sends certain maps to isomorphisms. Specifically, let  $(X, A)$  be a compact orbifold pair,  $P$  a compact orbifold-with-boundary and  $\partial A \leftarrow Q \hookrightarrow \partial P$  an identification between compact codimension-zero suborbifolds-with-boundary of  $\partial A$  and  $\partial P$ . We may form  $(X, A) \#_Q (P \times [0, 1], P)$  and consider the inclusion  $(X, A) \hookrightarrow (X, A) \#_Q (P \times [0, 1], P)$ . These inclusions are precisely the morphisms inverted by the localization  $\text{RepOrbSpcPair}^f \rightarrow \text{RepOrbSpc}_*^f$  from Proposition 3.15. Now, it is evident that the dual of the inclusion  $(X, A) \hookrightarrow (X, A) \#_Q (P \times [0, 1], P)$  is a map  $(X, \partial X - A^\circ)^{-T} \leftarrow ((X, \partial X - A^\circ) \#_Q (P \times [0, 1], P))^{-T}$  (the superscript  $-T$  denotes desuspension by the tangent bundle), which is also an isomorphism in  $\text{RepOrbSp}^f$ , so we are done.

We now define

$$(3-53) \quad D: \varinjlim_{N,k} \varinjlim_{\text{Vect}^2(R(*)_{N,k+2})} \text{RepOrbSpcPair}_{N,k}^f \rightarrow (\text{RepOrbSp}^f)^{\text{op}}.$$

As above, we define  $D((X, A)^{-\eta_X}) := (X, \partial X - A^\circ)^{\eta_X - TX}$  for  $(X, A)$  a compact orbifold pair. The functoriality under maps in  $\text{RepOrbSpcPair}_{N,k}^f$  is the same as before: the space of stable maps  $(Y, \partial Y - B^\circ)^{\eta_Y - TY} \rightarrow (X, \partial X - A^\circ)^{\eta_X - TX}$  is the same as the space of stable maps  $(Y, \partial Y - B^\circ)^{-TY} \rightarrow (X, \partial X - A^\circ)^{-TX}$ , so we simply take the same map  $D(Y, B) \rightarrow D(X, A)$  associated to our original map  $(X, A) \rightarrow (Y, B)$ . This recipe is compatible with the morphisms in the direct limit over  $\text{Vect}^2(R(*)_{N,k+2})$  by inspection (and then obviously with the direct limit over  $N$  and  $k$ ), so we obtain the functor (3-53).

By Proposition 3.33, to descend  $D$  from (3-53) to  $\text{RepOrbSp}^f$ , it suffices to verify that it sends certain maps to isomorphisms, but these are exactly the same as we already saw above. We therefore obtain the desired functor  $D$ .

By inspection,  $D$  sends cofiber sequences to cofiber sequences.



There is an obvious identification  $DDX = X$  for every  $X \in \text{RepOrbSp}^f$ , directly from the definition. To check that this defines a natural isomorphism of functors  $D^2 = \mathbf{1}$ , we just need to show that it is compatible with morphisms. Any morphism in  $\text{RepOrbSp}^f$  can be expressed as  $(X, A)^{-\eta_X} \rightarrow (Y, B)^{-\eta_Y}$  for compact orbifold pairs  $(X, A), (Y, B) \in \text{RepOrbSpcPair}_{N,k-2}$  and  $\eta \in \text{Vect}^2(R(*))_{N,k}$  and some map  $f^\eta: (X, A) \rightarrow (Y, B)$  which is a smooth embedding of orbifold pairs (ie  $A = X \cap B$  and  $X$  meets the boundary of  $Y$  transversely). We then have a collapse map  $(Y, \partial Y - B^\circ) \rightarrow (Y, Y - N_\epsilon X)$ , whose target is relatively homotopy equivalent to  $(X, \partial X - A^\circ)^{TY/TX}$ ; this collapse map is  $(Df)^{TY-\xi}$ . Now we may realize this collapse map as an embedding

$$(3-54) \quad (Y, \partial Y - B^\circ) \xrightarrow{\times\{\frac{1}{2}\}} (Y \times [0, 1], ((\partial Y - B^\circ) \times [0, 1]) \cup ((Y - N^\epsilon X) \times \{1\})).$$

We may now dualize it again to obtain

$$(3-55) \quad \Sigma(X, A) = (N_\epsilon X \times [0, 1], (N_\epsilon X \times \partial[0, 1]) \cup (A \times [0, 1]))$$

$$(3-56) \quad = (Y \times [0, 1], (B \times [0, 1]) \cup (Y \times \{0\}) \cup (N_\epsilon X \times \{1\})) \rightarrow \Sigma(Y, B),$$

which is indeed (the suspension of) the map we started with. □

Duality commutes with smash product: there are natural isomorphisms  $D(Z \wedge W) = DZ \wedge DW$  for  $Z, W \in \text{RepOrbSp}^f$ . Indeed, it suffices to define such a natural isomorphism of functors of  $Z$  and  $W$  in the left side of (3-49) (where we may assume all objects are compact orbifold pairs), and such an isomorphism is evident by inspection.

There is a natural pairing  $Z \wedge DZ \rightarrow R(*)$ , defined as follows. Let  $Z = (X, A)^{-\xi}$  be an orbifold pair desuspended by a vector bundle. The diagonal gives a map

$$(3-57) \quad (X, \partial X) \rightarrow (X, A)^{-\xi} \wedge (X, \partial X - A^\circ)^\xi.$$

We desuspend to obtain  $(X, \partial X)^{-TX} \rightarrow (X, A)^{-\xi} \wedge (X, \partial X - A^\circ)^{\xi-TX}$  and then dualize to obtain a map  $Z \wedge DZ \rightarrow X$ . Composing with the canonical map  $X \rightarrow R(*)$  defines the desired map  $Z \wedge DZ \rightarrow R(*)$ .

## 4 Vector bundles

### 4.1 Classifying spaces

For any compact Lie group  $G$ , let us argue that there is an object  $\mathbf{BG} \in \text{OrbSpc}$  which classifies principal  $G$ -bundles, in the sense that it carries a principal  $G$ -bundle

$\mathbf{E}G \rightarrow \mathbf{B}G$  such that the induced map from homotopy classes of maps  $X \rightarrow \mathbf{B}G$  to isomorphism classes of principal  $G$ -bundles over  $X$  is a bijection for any orbi-CW-complex  $X$ . (By Lemma 2.7, for any orbi-CW-complex  $X$ , necessarily paracompact, every principal  $G$ -bundle over  $X \times [0, 1]$  is pulled back from  $X$ , so there is indeed such a map.) Note that  $*/G$  has this representing property for all stacks, not just orbi-CW-complexes, however it is not itself an orbi-CW-complex unless  $G$  is finite, so it is not (in the present context)  $\mathbf{B}G$ .

**Lemma 4.1** *The classifying space  $\mathbf{B}G \in \text{OrbSpc}$  exists.*

**Proof** We argue as in Proposition 3.12. Construct, by induction, an orbi-CW-complex  $\mathbf{B}G$  carrying a faithful principal  $G$ -bundle  $\mathbf{E}G \rightarrow \mathbf{B}G$ . Begin with  $(\mathbf{B}G)_{-1} = \emptyset$ . Consider triples consisting of a map  $\partial D^k \times \mathbf{B}\Gamma \rightarrow (\mathbf{B}G)_{k-1}$ , a faithful principal  $G$ -bundle  $P$  over  $D^k \times \mathbf{B}\Gamma$ , and an isomorphism over  $\partial D^k \times \mathbf{B}\Gamma$  between the restriction of  $P$  and the pullback of  $(\mathbf{E}G)_{k-1}$ . Note that since  $P \rightarrow D^k \times \mathbf{B}\Gamma$  is faithful, the map  $\partial D^k \times \mathbf{B}\Gamma \rightarrow (\mathbf{B}G)_{k-1}$  must necessarily be representable. To define  $(\mathbf{B}G)_k$ , we attach a cell to  $(\mathbf{B}G)_{k-1}$  for each homotopy class of such triple (we may omit trivial homotopy classes, ie those which are induced by maps  $D^k \times \mathbf{B}\Gamma \rightarrow (\mathbf{B}G)_{k-1}$ ); the data of each triple tells us how to extend  $(\mathbf{E}G)_{k-1} \rightarrow (\mathbf{B}G)_{k-1}$  to  $(\mathbf{E}G)_k \rightarrow (\mathbf{B}G)_k$ .

Now we claim that  $\mathbf{E}G \rightarrow \mathbf{B}G$  is the desired universal principal  $G$ -bundle over an orbi-CW-complex. It suffices to show that for every triple consisting of a map  $\partial D^k \times \mathbf{B}\Gamma \rightarrow \mathbf{B}G$ , a principal  $G$ -bundle  $P$  over  $D^k \times \mathbf{B}\Gamma$ , and an isomorphism over  $\partial D^k \times \mathbf{B}\Gamma$  between the restriction of  $P$  and the pullback of  $\mathbf{E}G$ , we can extend the map and the isomorphism to  $D^k \times \mathbf{B}\Gamma$ . By cellular approximation, we may assume the map  $\partial D^k \times \mathbf{B}\Gamma \rightarrow \mathbf{B}G$  lands inside  $(\mathbf{B}G)_{k-1}$ . Now our principal  $G$ -bundle over  $D^k \times \mathbf{B}\Gamma$  is necessarily pulled back from  $\mathbf{B}\Gamma$  (since  $D^k$  is contractible) hence is classified by a conjugacy class of homomorphisms  $\Gamma \rightarrow G$ . In particular, it is pulled back from  $D^k \times \mathbf{B}(\Gamma/N)$  for  $N \trianglelefteq \Gamma$  the kernel. Since the principal  $G$ -bundle over  $\mathbf{B}G$  is faithful, this map also factors, uniquely, through  $D^k \times \mathbf{B}(\Gamma/N)$  by Lemma 3.4. Now that we have a representable map to  $(\mathbf{B}G)_{k-1}$ , we can appeal to the definition of  $(\mathbf{B}G)_k$  to see that the triple involving  $D^k \times \mathbf{B}(\Gamma/N)$  extends as desired, hence by precomposition the original triple as well.  $\square$

**Remark 4.2** Another construction of  $\mathbf{B}G$  is given in [29]. There, the  $G$ -CW-complex  $\mathbf{E}G$  is defined by the property of carrying a  $G$ -action with finite stabilizers such that  $(\mathbf{E}G)^H$  is contractible for every finite subgroup  $H \leq G$ . The orbispace  $\mathbf{B}G$  is then defined as the quotient  $(\mathbf{E}G)/G$ .

Note that since  $\mathbf{E}G \rightarrow \mathbf{B}G$  is faithful, a principal  $G$ -bundle  $P \rightarrow X$  is faithful if and only if the corresponding map  $X \rightarrow \mathbf{B}G$  is representable.

It is important to note that the extension property shown above in the proof that  $\mathbf{B}G$  represents the functor of *isomorphism classes* of principal  $G$ -bundles is strictly stronger than the representing property (though of course a posteriori it is equivalent). The extension property corresponds to a more homotopical ( $\infty$ -categorical or model categorical) universal property of  $\mathbf{B}G$ , and it will be used implicitly at later points, eg to know that every isomorphism of principal  $G$ -bundles is induced by a homotopy of maps to  $\mathbf{B}G$ .

**Remark 4.3** The object classifying principal  $G$ -bundles depends strongly on the category we are working in. For example, the CW-complex  $BG \in \mathbf{Spc}$  classifying principal  $G$ -bundles over CW-complexes evidently does not coincide with the orbi-CW-complex  $\mathbf{B}G \in \mathbf{OrbSpc}$  classifying principal  $G$ -bundles over orbi-CW-complexes. Rather, it is immediate that the right adjoint to the inclusion  $\mathbf{Spc} \hookrightarrow \mathbf{OrbSpc}$ , namely the classifying space functor, sends  $\mathbf{B}G$  to  $BG$  (and  $R(\mathbf{B}G)$  classifies principal  $G$ -bundles in the category  $\mathbf{RepOrbSpc}$ ). Similarly, if we were to define a larger category of “Lie orbispaces” allowing objects such as  $*/G$ , then the right adjoint (if it exists) to the inclusion of  $\mathbf{OrbSpc}$  into this larger category would send  $*/G$  to (what we have decided to call)  $\mathbf{B}G \in \mathbf{OrbSpc}$ . As a more explicit warning to the reader: the most natural meaning of the symbol  $\mathbf{B}G$  thus differs from context to context, and it should probably default to  $\mathbf{B}G := */G$  unless the contrary is explicitly stated, as we have done here.

## 4.2 Stable vector bundles

We discuss stable vector bundles on orbi-CW-complexes. The principal new feature in this discussion compared with the corresponding discussion for CW-complexes is that there are many different ways to “stabilize”. We will consider only two extreme notions: “coarse stabilization”, involving a direct limit over  $\bigoplus \mathbb{R}$ , or, equivalently, over  $\bigoplus V$  for arbitrary *coarse* vector bundles, and “stabilization”, involving a direct limit over  $\bigoplus V$  for arbitrary vector bundles  $V$ .

For an orbi-CW-complex  $X$ , let  $\mathbf{Vect}(X)$  denote the category whose objects are vector bundles over  $X$  and whose morphisms are homotopy classes of injective maps. As a set,  $\mathbf{Vect}(X)$  is the set of homotopy classes of maps  $X \rightarrow \bigsqcup_{n \geq 0} \mathbf{B}O(n)$ .

**Lemma 4.4** *The category  $\mathbf{Vect}(X)$  is filtered.* □

**Example 4.5** A vector bundle over  $\mathbf{B}G$  is a  $G$ -representation. Thus objects of  $\text{Vect}(\mathbf{B}G)$  are in bijection with elements of  $\mathbb{Z}_{\geq 0}^{\widehat{G}}$ , where  $\widehat{G}$  denotes the set of isomorphism classes of real irreducible representations of  $G$ . An automorphism of an object of  $\text{Vect}(\mathbf{B}G)$  also splits as a direct sum of isotypic pieces. The component group of the space of automorphisms of  $\rho^{\oplus n}$  for  $n > 0$  is  $\mathbb{Z}/2$  if  $\text{End}(\rho) = \mathbb{R}$  and is trivial otherwise (ie if  $\text{End}(\rho) = \mathbb{C}$  or  $\mathbb{H}$ ).

For two vector bundles  $V$  and  $W$  on  $X$ , let  $\pi_0 \text{Iso}(V, W)$  denote homotopy classes of isomorphisms  $V \rightarrow W$ . Vector bundles and isomorphisms up to homotopy form a groupoid  $\text{Vect}(X)_{\text{iso}}$ . A *stable isomorphism*  $V \dashrightarrow W$  up to homotopy is an element of

$$(4-1) \quad \pi_0 \text{Iso}^{\text{st}}(V, W) := \varinjlim_{E \in \text{Vect}(X)} \pi_0 \text{Iso}(V \oplus E, W \oplus E).$$

Vector bundles and stable isomorphisms also form a groupoid  $\text{Vect}(X)_{\text{iso}}^{\text{st}}$ . If we restrict (4-1) to coarse vector bundles  $E$ , we obtain the notion of a *coarsely stable isomorphism* and a resulting groupoid  $\text{Vect}(X)_{\text{iso}}^{\text{cst}}$ . If  $X$  is compact, then the sequence  $0 \hookrightarrow \underline{\mathbb{R}} \hookrightarrow \underline{\mathbb{R}}^2 \hookrightarrow \dots$  is cofinal in coarse vector bundles on  $X$ , so it is equivalent to stabilize just by these. When stabilizing with respect to all vector bundles, there seems to be no such nice canonical sequence (though see [29, Remark 1.4]). The notion of stable isomorphism is most reasonable when  $X$  is compact (or at least has enough vector bundles).

The groupoid of vector bundles and stable isomorphisms may be extended to a larger groupoid of *stable vector bundles* (similarly, the groupoid of vector bundles and coarsely stable isomorphisms extends to a groupoid of *coarsely stable vector bundles*). A (coarsely) stable vector bundle is a formal difference  $E - F$  (where  $F$  is coarse); if  $X$  is compact a coarse vector bundle is equivalently a formal difference  $E - \underline{\mathbb{R}}^n$ . An isomorphism of (coarsely) stable vector bundles  $(E - F) \rightarrow (E' - F')$  is a (coarsely) stable isomorphism  $E \oplus F' \dashrightarrow E' \oplus F$ ; note that we can indeed compose these. Provided  $X$  is compact, the groupoid of coarsely stable vector bundles is the direct limit of  $\text{Vect}(X) \xrightarrow{\oplus \underline{\mathbb{R}}} \text{Vect}(X) \xrightarrow{\oplus \underline{\mathbb{R}}} \dots$ . The groupoid of stable vector bundles is the direct limit of  $\text{Vect}(X)$  over the 2-categorical refinement  $\text{Vect}^2(X)$  of  $\text{Vect}(X)$  in which a morphism is an inclusion of vector bundles and a 2-morphism is a homotopy class of paths of inclusions.

**Example 4.6** Isomorphism classes of stable vector bundles on  $\mathbf{B}G$  are in bijection with  $\mathbb{Z}^{\widehat{G}}$ . The automorphism group of every one is the product of  $\mathbb{Z}/2$  over all  $\rho \in \widehat{G}$  with  $\text{End}(\rho) = \mathbb{R}$ . Coarsely stable vector bundles on  $\mathbf{B}G$  are in bijection with  $\mathbb{Z} \oplus \mathbb{Z}_{\geq 0}^{\widehat{G}-1}$ ,

and the automorphism group of a coarsely stable vector bundle is  $\mathbb{Z}/2$  (corresponding to  $\rho = \mathbf{1}$ ) times the product of  $\mathbb{Z}/2$  over all  $\rho \neq \mathbf{1}$  for which  $\text{End}(\rho) = \mathbb{R}$  and whose isotypic piece is nontrivial.

There is an orbi-CW-complex  $\mathbf{bo} := \varinjlim_n \mathbf{BO}(n)$  defined as the infinite mapping cylinder of the maps  $\mathbf{BO}(n) \xrightarrow{\oplus \mathbb{R}} \mathbf{BO}(n+1)$ . This orbispace  $\mathbf{bo}$  classifies coarsely stable vector bundles: a map  $X \rightarrow \mathbf{bo}$  up to homotopy is the same as a coarsely stable vector bundles of dimension zero over  $X$  up to isomorphism. The notation  $\mathbf{bo}$  is chosen to coincide with the notation for a corresponding global space defined by Schwede [34, Section 2.4], which has the same classifying property; see Section 6.2 below.

One might desire an orbispace  $\mathbf{BO}$  classifying stable vector bundles; intuitively, it should be the group completion of  $\bigsqcup_n \mathbf{BO}(n)$ . There is indeed a global space  $\mathbf{BO}$  [34, Section 2.4] which is the group completion [34, Theorem 2.5.33] and which has this desired classifying property, as we will see in Section 6.2. Note that if we were to naively apply the usual definition of group completion to the monoid  $\bigsqcup_n \mathbf{BO}(n)$ , we would need to apply  $B$  to it, and this would involve gluing along nonrepresentable maps. In fact:

**Lemma 4.7** *There does not exist an orbi-CW-complex  $\mathbf{BO}$  and a functorial bijection between isomorphism classes of stable vector bundles over orbi-CW-complexes  $X$  and homotopy classes of maps  $X \rightarrow \mathbf{BO}$ .*

**Proof** Consider a vector bundle  $V$  over a CW-complex  $X$  which is not stably trivial, eg one with nontrivial Pontryagin classes. Now fix a nontrivial irreducible representation  $Q$  of a finite group  $G$ , and consider the stable vector bundle  $(V - \mathbb{R}^{|V|}) \otimes Q$  over  $X \times \mathbf{BG}$ . The restriction of this stable vector bundle to any  $* \times \mathbf{BG}$  is evidently zero. Hence if it were pulled back from a classifying map  $X \times \mathbf{BG} \rightarrow \mathbf{BO}$ , each restriction  $* \times \mathbf{BG} \rightarrow \mathbf{BO}$  would factor through  $* \rightarrow \mathbf{BO}$ , hence by Lemma 3.4 the entire map  $X \times \mathbf{BG} \rightarrow \mathbf{BO}$  would factor through  $X \rightarrow \mathbf{BO}$ , implying that our given stable vector bundle is pulled back from  $X$ . On the other hand, stable vector bundles on  $X \times \mathbf{BG}$  are simply the direct sum over  $\widehat{G}$  of stable vector bundles on  $X$ , so our given stable vector bundle is definitely not pulled back from  $X$ . As in Example 3.20, the key point in this argument was the use of Lemma 3.4. □

### 4.3 Stable structures on vector bundles

A *structure on vector bundles*  $\mathfrak{S}$  is a sequence of orbi-CW-complexes  $\mathbf{BS}(n)$  for  $n \geq 0$  each carrying a vector bundle  $\xi_n$  of rank  $n$  (equivalently, we could specify the

maps  $\mathbf{B}\mathfrak{S}(n) \rightarrow \mathbf{B}O(n)$ ); we write  $\xi$  for  $\bigsqcup_{n \geq 0} \xi_n$  over  $\bigsqcup_{n \geq 0} \mathbf{B}\mathfrak{S}(n)$ . An  $\mathfrak{S}$ -structure on a vector bundle  $V$  over an orbi-CW-complex  $X$  is a map  $f: X \rightarrow \bigsqcup_n \mathbf{B}\mathfrak{S}(n)$  together with an isomorphism  $V = f^*\xi$ . The set of  $\mathfrak{S}$ -structures up to homotopy on a vector bundle  $V$  is denoted  $\text{Str}_{\mathfrak{S}}(V)$ . An isomorphism  $V \xrightarrow{\sim} W$  induces a bijection  $\text{Str}_{\mathfrak{S}}(V) \xrightarrow{\sim} \text{Str}_{\mathfrak{S}}(W)$ .

The notion of an  $\mathfrak{S}$ -structure provides a common language for many structures of interest on vector bundles. In particular: for  $\mathbf{B}\mathfrak{S}(n) = \mathbf{B}SO(n)$ , an  $\mathfrak{S}$ -structure is an orientation; for  $\mathbf{B}\mathfrak{S}(n) = \mathbf{B}U(n/2)$ , an  $\mathfrak{S}$ -structure is a complex structure; for  $\mathbf{B}\mathfrak{S}(n) = *$ , an  $\mathfrak{S}$ -structure is a trivialization (or framing).

A *shift* on a structure on vector bundles  $\mathfrak{S}$  is a collection of maps  $s_n: \mathbf{B}\mathfrak{S}(n) \rightarrow \mathbf{B}\mathfrak{S}(n+1)$  and isomorphisms  $s_n^*\xi_{n+1} = \xi_n \oplus \underline{\mathbb{R}}$ ; equivalently, we could specify for each diagram

$$(4-2) \quad \begin{array}{ccc} \mathbf{B}\mathfrak{S}(n) & \xrightarrow{s_n} & \mathbf{B}\mathfrak{S}(n+1) \\ \downarrow \xi_n & & \downarrow \xi_{n+1} \\ \mathbf{B}O(n) & \xrightarrow{\oplus \underline{\mathbb{R}}} & \mathbf{B}O(n+1) \end{array}$$

a homotopy between the two compositions. A shift on  $\mathfrak{S}$  gives rise to natural maps  $\text{Str}_{\mathfrak{S}}(V) \rightarrow \text{Str}_{\mathfrak{S}}(V \oplus \underline{\mathbb{R}})$ , and a homotopy class of *coarsely stable*  $\mathfrak{S}$ -structure on  $V$  is an element of

$$(4-3) \quad \text{Str}_{\mathfrak{S}}^{\text{cst}}(V) := \varinjlim_n \text{Str}_{\mathfrak{S}}(V \oplus \underline{\mathbb{R}}^n).$$

We have  $\text{Str}_{\mathfrak{S}}^{\text{cst}}(V) = \text{Str}_{\mathfrak{S}}(V)$  if (4-2) is a homotopy pullback square (in the sense that the relevant lifting property holds for every  $(D^k, \partial D^k) \times \mathbf{B}G$ ). It also makes sense to put a coarsely stable  $\mathfrak{S}$ -structure on a coarsely stable vector bundle:  $\text{Str}_{\mathfrak{S}}^{\text{cst}}(F - \underline{\mathbb{R}}^k) := \varinjlim_n \text{Str}_{\mathfrak{S}}(V \oplus \underline{\mathbb{R}}^{n-k})$ , and coarsely stable isomorphisms between coarsely stable vector bundles induce maps between their sets of homotopy classes of coarsely stable  $\mathfrak{S}$ -structures. The orbi-CW-complex  $\mathbf{b}\mathfrak{S} := \varinjlim_{n \rightarrow \infty} \mathbf{B}\mathfrak{S}(n)$  (infinite mapping cylinder) classifies coarsely stable vector bundles with  $\mathfrak{S}$ -structure, in the sense that homotopy classes of maps  $X \rightarrow \mathbf{b}\mathfrak{S}$  are in bijection with isomorphism classes of coarsely stable vector bundles with  $\mathfrak{S}$ -structure.

The set  $\text{Str}_{\mathfrak{S}}^{\text{cst}}(V)$  has a canonical involution defined by noting the canonical isomorphism  $\text{Str}_{\mathfrak{S}}^{\text{cst}}(V) = \text{Str}_{\mathfrak{S}}^{\text{cst}}(V \oplus \underline{\mathbb{R}})$  and acting via  $\text{id}_V \oplus (-1)$  on  $V \oplus \underline{\mathbb{R}}$ . Note that, having defined the involution on every  $\text{Str}_{\mathfrak{S}}^{\text{cst}}$  in this way, the isomorphism  $\text{Str}_{\mathfrak{S}}^{\text{cst}}(V) = \text{Str}_{\mathfrak{S}}^{\text{cst}}(V \oplus \underline{\mathbb{R}})$  respects involutions since  $\begin{pmatrix} -1 & 0 \\ 0 & 1 \end{pmatrix}$  and  $\begin{pmatrix} 1 & 0 \\ 0 & -1 \end{pmatrix}$  lie in the same component of  $O(2)$ .

A coarsely stable orientation is simply an orientation, due to the aforementioned condition that (4-2) be a homotopy pullback being satisfied. To define coarsely stable complex structures, we should take  $\mathfrak{S}_n := \mathbf{BU}(\lfloor n/2 \rfloor)$  and  $\xi_n$  to be the tautological bundle plus  $\mathbb{R}$  for  $n$  odd, and the map  $s$  to be addition of  $\mathbb{R}$  (choosing a convention for which homotopy class of complex structure on  $\mathbb{R}^2$  to use). A coarsely stable complex structure is weaker than a complex structure (even in even dimensions). A coarsely stable framing exists only on coarse vector bundles.

A *stable structure on vector bundles* is a structure on vector bundles  $\mathfrak{S}$  together with a map  $i : * \rightarrow \mathbf{B}\mathfrak{S}(1)$  with an isomorphism  $i^*\xi = \mathbb{R}$  and maps

$$s_{n,m} : \mathbf{B}\mathfrak{S}(n) \times \mathbf{B}\mathfrak{S}(m) \rightarrow \mathbf{B}\mathfrak{S}(n + m)$$

with isomorphisms  $\xi_n \oplus \xi_m = s_{n,m}^*\xi_{n+m}$  which are associate and graded symmetric in the sense that we now explain. Associativity means that the two resulting maps  $\mathbf{B}\mathfrak{S}(n) \times \mathbf{B}\mathfrak{S}(m) \times \mathbf{B}\mathfrak{S}(k) \rightarrow \mathbf{B}\mathfrak{S}(n + m + k)$  covered by isomorphisms  $\xi_n \oplus \xi_m \oplus \xi_k = \xi_{n+m+k}$  are homotopic. Note that  $s := s_{n,1} \circ (\text{id} \times i)$  defines a shift on  $\mathfrak{S}$ , so we can already make sense of coarse stabilization. Graded symmetry is the statement that the maps  $\text{Str}_{\mathfrak{S}}(V) \times \text{Str}_{\mathfrak{S}}(W) \rightarrow \text{Str}_{\mathfrak{S}}^{\text{cst}}(V \oplus W)$  given by adding in either order differ by  $(-1)^{|V||W|}$ , where  $-1$  denotes the canonical involution on  $\text{Str}_{\mathfrak{S}}^{\text{cst}}$  defined above. We thus obtain graded symmetric maps

$$(4-4) \quad \text{Str}_{\mathfrak{S}}^{\text{cst}}(V) \times \text{Str}_{\mathfrak{S}}^{\text{cst}}(W) \rightarrow \text{Str}_{\mathfrak{S}}^{\text{cst}}(V \oplus W)$$

defined as the direct limit over  $n$  and  $m$  of  $(-1)^{n|W|}$  times the map  $\text{Str}_{\mathfrak{S}}(V \oplus \mathbb{R}^n) \times \text{Str}_{\mathfrak{S}}(W \oplus \mathbb{R}^m) \rightarrow \text{Str}_{\mathfrak{S}}(V \oplus W \oplus \mathbb{R}^{n+m})$ .

A homotopy class of *stable  $\mathfrak{S}$ -structure* on  $V$  is an element of the direct limit

$$(4-5) \quad \text{Str}_{\mathfrak{S}}^{\text{st}}(V) := \varinjlim_W \text{Str}_{\mathfrak{S}}^{\text{cst}}(V \oplus W)$$

over the category whose objects are vector bundles  $W$  equipped with a homotopy class of coarsely stable  $\mathfrak{S}$ -structure and whose morphisms are injections of vector bundles  $V \hookrightarrow W$  together with a homotopy class of coarsely stable  $\mathfrak{S}$ -structure on  $W/V$  such that the resulting homotopy class of coarsely stable  $\mathfrak{S}$ -structure on  $W = V \oplus W/V$  is the given one, modulo homotopy. (We warn the reader that the forgetful functor from this category to  $\text{Vect}(X)$  need not be cofinal.)

**Lemma 4.8** *The indexing category above is filtered.*

**Proof** It is nonempty since there is the zero vector bundle. Given objects  $V$  and  $V'$ , they both admit morphisms to the same object  $V \oplus V'$ , namely  $\oplus V'$  in the former case and  $\oplus V$  in the latter case twisted by  $(-1)^{|V||V'|}$ . Finally, suppose we are given two morphisms  $V \rightarrow V \oplus W$  and  $V \rightarrow V \oplus W'$  where  $V \oplus W = V \oplus W'$ . Then compose further with  $\oplus V$ , so that the two compositions become  $\oplus (W \oplus V)$  and  $\oplus (W' \oplus V)$ , which we assumed were the same — notice that  $|W| = |W'|$ , so the sign twist in each case is the same.  $\square$

There are associative graded symmetric maps

$$(4-6) \quad \text{Str}_{\mathfrak{S}}^{\text{st}}(V) \times \text{Str}_{\mathfrak{S}}^{\text{st}}(W) \rightarrow \text{Str}_{\mathfrak{S}}^{\text{st}}(V \oplus W).$$

In particular,  $\text{Str}_{\mathfrak{S}}^{\text{st}}(0)$  is an abelian group (to see that it has inverses, note that an element of  $\text{Str}_{\mathfrak{S}}^{\text{st}}(0)$  is given by a vector bundle  $V$  with two coarsely stable  $\mathfrak{S}$ -structures, and exchange them with a sign twist), each  $\text{Str}_{\mathfrak{S}}^{\text{st}}(V)$  is either empty or a principal homogeneous space for  $\text{Str}_{\mathfrak{S}}^{\text{st}}(0)$ , and the addition maps (4-6) are maps of  $\text{Str}_{\mathfrak{S}}^{\text{st}}(0)$ -sets. Each  $\text{Str}_{\mathfrak{S}}(V)$  also carries a canonical involution given by adding  $\mathbb{R}$  and acting on it by  $-1$ .

It also makes sense to discuss stable structures on stable vector bundles, and the above continues to apply.

A stable orientation is the same as an orientation. A stable almost complex structure is strictly weaker than a coarsely stable almost complex structure. A stable framing is the same as a coarsely stable framing.

## 5 Orbifold bordism

### 5.1 Definitions

We define orbifold bordism  $\Omega_*(X, A)$  and derived orbifold bordism  $\Omega_*^{\text{der}}(X, A)$  for any orbispace pair  $(X, A)$  as follows.

Consider compact orbifolds with boundary  $Z$  together with a representable map  $f: (Z, \partial Z) \rightarrow (X, A)$ . A bordism between such pairs  $(Z_1, f_1)$  and  $(Z_2, f_2)$  consists of a compact orbifold with boundary  $W$  with a codimension-zero embedding  $Z_1 \sqcup Z_2 \hookrightarrow \partial W$  and a representable map  $f: (W, \partial W - (Z_1^\circ \cup Z_2^\circ)) \rightarrow (X, A)$  whose restrictions to  $Z_1$  and  $Z_2$  are  $f_1$  and  $f_2$ , respectively. (Alternatively, one could regard  $W$  as a compact orbifold with corners, where the corner locus is precisely



$\partial Z_1 \cup \partial Z_2 \subseteq \partial W$ .) Bordism is an equivalence relation (by a collaring result, which allows one to glue together bordisms). Now  $\Omega_*(X, A)$  is the set of pairs  $(Z, f)$  modulo compact bordism, graded by dimension.

We now consider a “derived” version of this construction. A *derived orbifold chart (with boundary)*  $Z$  is a tuple  $(D, E, s)$ , where  $D$  (the “domain”) is an orbifold (with boundary),  $E$  (the “obstruction bundle”) is a vector bundle, and  $s$  (“the obstruction section”) is a smooth section. A derived orbifold chart with boundary is called compact if and only if the zero set of  $s$  is compact. A *restriction* of a derived orbifold chart with boundary replaces  $D$  with an open subset of  $D$  which contains the zero set of  $s$  (we may always restrict to a precompact subset of  $D$ , hence the noncompactness of  $D$  is never an issue). A *stabilization* of a derived orbifold chart with boundary  $Z = (D, E, s)$  replaces  $D$  with the total space of a vector bundle  $F$  over  $D$ , replaces  $E$  with its direct sum with  $F$ , and replaces  $s$  with its direct sum with the identity map on  $F$ . Bordism of derived orbifold charts is defined as before. Now  $\Omega_*^{\text{der}}(X, A)$  is the set of compact derived orbifold charts with boundary  $Z = (D, E, s)$  together with a representable map  $(D, \partial D) \rightarrow (X, A)$ , modulo compact bordism, restriction and stabilization. It is graded by virtual dimension  $\dim D - \dim E$ . There is an obvious map  $\Omega_* \rightarrow \Omega_*^{\text{der}}$ .

While bordism of orbifolds is obviously an equivalence relation (since boundaries of orbifolds with boundary have collars), the analogous assertion for bordisms of derived orbifold charts relies on enough vector bundles.

**Proposition 5.1** *Two compact derived orbifold charts with boundary representable over  $(X, A)$  represent the same element of  $\Omega_*^{\text{der}}(X, A)$  if and only if they are compactly bordant after restricting and stabilizing.*

**Proof** It suffices to check that the stated relation is transitive. Suppose that  $Z_1 \sim Z_2 \sim Z_3$ , and let us show that  $Z_1 \sim Z_3$ . The key obstacle to overcome is that the vector bundles by which one stabilizes  $Z_2$  to become bordant to (stabilizations of)  $Z_1$  and  $Z_3$  may not coincide.

We begin by introducing a new perspective on stabilization. Let  $(D, E, s)$  be a derived orbifold chart, and let  $Q$  be a vector bundle over  $D$  together with a surjection  $f : Q \twoheadrightarrow E$ . We obtain a new derived orbifold chart

$$(5-1) \quad (\{d \in D, q \in Q : s(d) = f(q)\}, Q, \pi_Q).$$

In fact, this new derived orbifold chart is a stabilization of  $(D, E, s)$ : indeed a choice of splitting  $Q = E \oplus \ker f$  identifies the new derived orbifold chart above with the stabilization of  $(D, E, s)$  by  $\ker f$ .

Let us now observe that stabilization is transitive: a stabilization of a stabilization is a stabilization. The point is just that if  $(D, E, s) \rightsquigarrow (D', E', s') \rightsquigarrow (D'', E'', s'')$  are stabilizations, then the vector bundle  $W$  by which the second stabilization stabilizes is pulled back from  $D \subseteq D'$  (the first stabilization says that  $D'$  is the total space of a vector bundle over, hence has a projection map down to,  $D$ ). Choosing such an identification of  $W$  with the pullback of its restriction to  $D$  identifies  $(D'', E'', s'')$  with a stabilization of  $(D, E, s)$ .

We now return to the problem at hand. We have bordisms  $C_{12}$  and  $C_{23}$  between stabilizations of  $Z_1, Z_2, Z_3$ . By making a small deformation, we may assume that these bordisms are collared, ie near the boundary are the product of the boundary times  $[0, \varepsilon)$ . Consider the orbispace  $C_{12} \cup_{Z_2} C_{23}$ , ie the gluing of the “domains” of the corresponding derived orbifolds, possibly after restricting to precompact open subsets thereof. By enough vector bundles Theorem 3.23, there is a module faithful vector bundle  $Q$  over this space. There thus exists an  $N < \infty$  and surjections  $\Phi_{12}$  and  $\Phi_{23}$  from  $Q^{\oplus N}|_{C_{12}}$  and  $Q^{\oplus N}|_{C_{23}}$  to the obstruction spaces  $E_{12}$  of  $C_{12}$  and  $E_{23}$  of  $C_{23}$ , respectively (say, independent of the radial coordinate of the collar near the boundary), thus determining stabilizations of  $C_{12}$  and  $C_{23}$ , respectively. The resulting composite stabilizations of  $Z_2$  on the boundary are thus determined by surjections  $\Psi_{12} \circ \Phi_{12}$  and  $\Psi_{23} \circ \Phi_{23}$  from  $Q^{\oplus N}$  to the obstruction space  $E_2$  of  $Z_2$ , where  $\Psi_{12}: E_{12} \rightarrow E_2$  and  $\Psi_{23}: E_{23} \rightarrow E_2$  are the surjections inducing the stabilizations of  $Z_2$  on the boundaries of  $C_{12}$  and  $C_{23}$ , respectively. If these surjections  $\Psi_{12} \circ \Phi_{12}$  and  $\Psi_{23} \circ \Phi_{23}$  from  $Q^{\oplus N}$  to  $E_2$  are homotopic through surjections, we may insert such a homotopy in the collar coordinate and glue the stabilizations of  $C_{12}$  by  $\Phi_{12}$  and  $C_{23}$  by  $\Phi_{23}$  together to obtain the desired glued bordism between (stabilizations of)  $Z_1$  and  $Z_3$ . By replacing  $N$  with  $2N$  and replacing  $\Phi_{12}$  and  $\Phi_{23}$  with  $\Phi_{12} \oplus 0$  and  $0 \oplus \Phi_{23}$ , respectively, the desired homotopy through surjections is simply the obvious linear interpolation.  $\square$

**Remark 5.2** A derived orbifold is an object with an atlas of derived orbifold charts. It is a consequence of enough vector bundles that every derived orbifold has in fact a global chart. Thus we may (and do) define derived orbifold bordism groups purely in terms of derived orbifold charts, without delving into the details of the definition of derived orbifolds. The cost of this approach is that enough vector bundles becomes a

crucial ingredient in the proofs of most properties of derived orbifold bordism as we have defined it here.

### 5.2 Basic properties

The sets  $\Omega_d$  and  $\Omega_d^{\text{der}}$  are both abelian groups under disjoint union; each element is its own inverse.

These groups  $\Omega_d$  and  $\Omega_d^{\text{der}}$  are functorial under representable maps of pairs, namely they define functors  $\text{RepOrbSpcPair} \rightarrow \text{Ab}$ . In fact, they descend to functors

$$(5-2) \quad \text{RepOrbSpc}_* \rightarrow \text{Ab},$$

which can be seen either directly from the definition or by appealing to Proposition 3.15. (The proof is exactly as for classical bordism, so we omit it.)

There is a natural map  $\Omega_d \rightarrow \Omega_d^{\text{der}}$  (take  $E = 0$ ). Since a section of a vector bundle over a manifold can be perturbed to be transverse to zero, the map  $\Omega_d(X, A) \rightarrow \Omega_d^{\text{der}}(X, A)$  is an isomorphism for  $(X, A) \in \text{Spc}_*$ .

There are natural product maps

$$(5-3) \quad \Omega_*(X, A) \otimes \Omega_*(Y, B) \rightarrow \Omega_*((X, A) \times (Y, B)),$$

$$(5-4) \quad \Omega_*^{\text{der}}(X, A) \otimes \Omega_*^{\text{der}}(Y, B) \rightarrow \Omega_*^{\text{der}}((X, A) \times (Y, B)),$$

given simply by taking product of (derived) orbifolds.

(Derived) orbifold bordism groups also satisfy exactness:

**Proposition 5.3** *The functors  $\Omega_d$  and  $\Omega_d^{\text{der}}$  send any cofiber sequence (3-25) to an exact sequence of abelian groups.*

**Proof** We treat both cases ( $\Omega_d$  and  $\Omega_d^{\text{der}}$ ) simultaneously, writing  $\Omega_*^{(\text{der})}$  for either one.

It is immediate that any element of  $\Omega_*^{(\text{der})}(X, A)$  represented by something mapped entirely to  $A$  is zero (multiply by  $I$  to obtain a bordism to the empty set). It follows that the composition  $\Omega_*^{(\text{der})}(Y, B) \rightarrow \Omega_*^{(\text{der})}(X, A) \rightarrow \Omega_*^{(\text{der})}(X, A \cup_B Y)$  vanishes.

Now suppose an element  $(Z, \partial Z)$  of  $\Omega_*^{(\text{der})}(X, A)$  is sent to zero in  $\Omega_*^{(\text{der})}(X, A \cup_B Y)$ . There is thus a nullbordism  $C$  of  $(Z, \partial Z)$  over  $(X, A \cup_B Y)$  — in the case of  $\Omega_*^{\text{der}}$ , this

uses Proposition 5.1. The boundary of this bordism consists of  $Z$  (mapped to  $(X, A)$ ) and its complement, which is mapped to  $A \cup_B Y$ . Replace the map  $f: C \rightarrow X$  with its composition with a small perturbation of the identity  $\Phi: X \rightarrow X$  satisfying  $\Phi(A) \subseteq A$ ,  $\Phi(Y) \subseteq Y$  and  $\Phi(\text{Nbd } B) \subseteq B$ ; such a map  $\Phi$  may be constructed by induction on cells. Since the closure of  $\Phi^{-1}(Y - B)$  is disjoint from  $B$ , it follows that the closure of the set  $(f|_{\partial C})^{-1}(Y - B)$  is disjoint from  $Z \subseteq \partial C$ . Now take  $Z' \subseteq \partial C$  a compact codimension-zero submanifold with boundary, disjoint from  $Z$ , containing  $(f|_{\partial C})^{-1}(Y - B)$ . Thus  $(Z', \partial Z') \rightarrow (Y, B)$  represents an element of  $\Omega_*^{(\text{der})}(Y, B)$  which is sent to  $Z$  in  $\Omega_*^{(\text{der})}(X, A)$ .  $\square$

Applying Proposition 5.3 to the Puppe sequence gives a long exact sequence, which acquires the usual form once we observe that  $\Omega_*(X, A) = \Omega_{*+1}((X, A) \times (I, \partial I))$  (and likewise for  $\Omega_*^{\text{der}}$ ), as we will see next. Namely, for any cofiber sequence (3-25), we obtain a (bi-infinite) long exact sequence

$$(5-5) \quad \cdots \rightarrow \Omega_*(Y, B) \rightarrow \Omega_*(X, A) \rightarrow \Omega_*(X, A \cup_B Y) \rightarrow \Omega_{*-1}(Y, B) \rightarrow \cdots,$$

and the same for  $\Omega_*^{\text{der}}$ .

**Example 5.4** Here is a way to detect nontrivial negative-degree classes in derived bordism. Let  $G$  be any finite group. There is an *ungraded* map

$$(5-6) \quad \Omega_*(\mathbf{B}G) \rightarrow \Omega_*(*),$$

$$(5-7) \quad M/G \mapsto M^G;$$

every representable map  $N \rightarrow \mathbf{B}G$  is of the form  $M/G \rightarrow \mathbf{B}G$  for  $M = N \times_{\mathbf{B}G} *$ . Similarly, there is an ungraded map

$$(5-8) \quad \Omega_*^{\text{der}}(\mathbf{B}G) \rightarrow \Omega_*^{\text{der}}(*) = \Omega_*(*),$$

$$(5-9) \quad (M, E, s)/G \mapsto (M^G, E^G, s|_{M^G}).$$

One should be careful to note that this map does indeed respect bordism (in particular, stabilization). For any  $G$ -representation  $V$ , this map sends

$$(5-10) \quad (\mathbf{B}G, V/G, 0) \in \Omega_{-\dim V}^{\text{der}}(\mathbf{B}G)$$

to  $(*, V^G, 0) \in \Omega_{-\dim V}^{\text{der}}(*)$ , which is nonzero if and only if  $V^G = 0$ . We conclude that if  $V^G = 0$  then  $\Omega_{-\dim V}^{\text{der}}(\mathbf{B}G) \neq 0$ .

### 5.3 (Inverse) Thom maps

For any vector bundle  $V$  over  $X$ , there are natural *inverse Thom maps* (terminology following Schwede [34, Section 6])

$$(5-11) \quad \Omega_d(X, A) \rightarrow \Omega_{d+|V|}((X, A)^V),$$

$$(5-12) \quad \Omega_d^{\text{der}}(X, A) \rightarrow \Omega_{d+|V|}^{\text{der}}((X, A)^V),$$

given by replacing a given (derived) orbifold with the Thom space of the pullback of  $V$ . We also have *Thom maps* in the opposite direction

$$(5-13) \quad \Omega_{d+|V|}((X, A)^V) \rightarrow \Omega_d(X, A),$$

$$(5-14) \quad \Omega_{d+|V|}^{\text{der}}((X, A)^V) \rightarrow \Omega_d^{\text{der}}(X, A),$$

given by intersecting with the zero section of  $V$ . More precisely, the Thom map on  $\Omega_*$  is only defined for coarse vector bundles  $V$ , and it requires an appeal to Sard’s theorem to conclude that intersecting with a generic perturbation of the zero section of  $V$  is transverse. The Thom map on  $\Omega_*^{\text{der}}$  is defined for all vector bundles  $V$  and consists simply of adding  $V$  to the obstruction bundle and the identity section to the obstruction section.

**Proposition 5.5** *The Thom map and the inverse Thom map are inverses.*

**Proof** We have four compositions to show are the identity map:

$$(5-15) \quad \Omega_d^{(\text{der})}(X, A) \rightarrow \Omega_{d+|V|}^{(\text{der})}((X, A)^V) \rightarrow \Omega_d^{(\text{der})}(X, A),$$

$$(5-16) \quad \Omega_{d+|V|}^{(\text{der})}((X, A)^V) \rightarrow \Omega_d^{(\text{der})}(X, A) \rightarrow \Omega_{d+|V|}^{(\text{der})}((X, A)^V).$$

The map (5-15) for  $\Omega_*$  is the identity by inspection. The map (5-15) for  $\Omega_*^{\text{der}}$  is the identity since its action on a given derived orbifold chart is to stabilize by  $V$ . The map (5-16) for  $\Omega_*$  is also the identity by inspection — given a transverse perturbation  $\varepsilon$  of the zero section which is transverse to a given orbifold, consider replacing  $(X, A)^V$  with a small tubular neighborhood of the image of  $\varepsilon$  relative its boundary.

The map (5-16) for  $\Omega_*^{\text{der}}$  may be expressed alternatively as

$$(5-17) \quad \Omega_{d+|V|}^{\text{der}}((X, A)^V) \rightarrow \Omega_{d+2|V|}^{\text{der}}((X, A)^{V \oplus V}) \rightarrow \Omega_{d+|V|}^{\text{der}}((X, A)^V),$$

which looks very much like (5-15), except it is not quite the same since here the first map “inflates” along the second copy of  $V$  whereas the second map intersects along

the zero section of the first copy of  $V$ . However, we may note that  $(X, A)^{V \oplus V}$  has an automorphism, homotopic to the identity map, given by the matrix  $\begin{pmatrix} 0 & 1 \\ -1 & 0 \end{pmatrix} \cdot \text{id}_V$ , conjugation by which turns the second map into intersection with the second copy of  $V$ , putting our composition into the form (5-15) for  $\Omega_*^{\text{der}}$ , which we already saw is the identity map.  $\square$

Given the Thom isomorphism, we may extend  $\Omega_*$  and  $\Omega_*^{\text{der}}$  to orbispectra as follows. Bordism  $\Omega_*$  extends to naive orbispectra  $\text{RepOrbSpc}[\Sigma^{-1}]$  by taking

$$\Omega_*(\Sigma^{-n}(X, A)) := \Omega_{*+n}(X, A),$$

which is consistent since  $\Omega_*(X, A) = \Omega_{*+1}(\Sigma(X, A))$  by the Thom isomorphism. Derived bordism  $\Omega_*^{\text{der}}$  extends to genuine orbispectra  $\text{RepOrbSp}^f$  by taking

$$\Omega_*((X, A)^{-V}) := \Omega_{*+|V|}(X, A),$$

which is again consistent by the Thom isomorphism.

When  $V$  is not coarse, the inverse Thom map  $\Omega_*(X, A) \rightarrow \Omega_{*+|V|}((X, A)^V)$  is in general not an isomorphism. It is thus natural to ask whether  $\Omega_*((X, A)^V)$  may be expressed as bordism classes of some class of (derived) orbifolds mapping to  $(X, A)$  (rather than  $(X, A)^V$ ). We will see how to do this below, based on Wasserman’s theorem, which we will meet shortly. This is the key to extending  $\Omega_*$  to genuine orbispectra.

For the moment, we will observe that  $\Omega_* \rightarrow \Omega_*^{\text{der}}$  is the *localization* at the inverse Thom maps, in the following sense:

**Lemma 5.6** *For finite orbi-CW-pairs  $(X, A)$ , the natural map*

$$(5-18) \quad \Omega_* \left[ \frac{1}{\tau} \right] (X, A) := \lim_{V/X} \Omega_{*+|V|}((X, A)^V) \xrightarrow{\simeq} \lim_{V/X} \Omega_{*+|V|}^{\text{der}}((X, A)^V) = \Omega_*^{\text{der}}(X, A)$$

*is an isomorphism.*

**Proof** We prove surjectivity. Let  $(D, E, s)$  be a derived orbifold chart which is representable over  $(X, A)$ . To obtain the corresponding derived orbifold chart over  $(X, A)^V$ , we simply replace  $D$  with the total space of the pullback of  $V$  to it. By enough vector bundles (Theorem 3.23), we may take  $V$  so that its pullback to  $D$

surjects onto  $E$ . Now we may perturb  $s$  by adding to it (epsilon times) this surjection, thus making it transverse. Hence our derived orbifold chart lies in the image of  $\Omega_{*+|V|}((X, A)^V) \rightarrow \Omega_{*+|V|}^{\text{der}}((X, A)^V)$ .

Injectivity follows from the same argument applied to a derived orbifold bordism between two orbifolds. □

### 5.4 Wasserman’s theorem

A remarkable observation of Wasserman [38] provides a sufficient condition under which a section of a vector bundle over an orbifold may be perturbed to become transverse to zero. In particular, it gives a condition under which a derived orbifold is bordant to an orbifold.

To state this condition, let us fix some notation. For a vector bundle  $V$  over an orbispace and a point  $p$ , we may decompose the fiber  $V_p$  into a direct sum of isotypic pieces, indexed by the set  $\widehat{G}_p$  of isomorphism classes of real irreducible representations of the isotropy group  $G_p$  of  $p$ . In particular, we may split  $V_p$  as the direct sum of the isotropy invariant part  $(V_p)^{G_p} = (V_p)_1$  and the direct sum  $(V_p)_{\widehat{G}_p-1}$  of isotypic pieces of nontrivial representations. We denote by  $V_{\widehat{\text{iso}}-1} \subseteq V$  the sum of the isotypic pieces associated to nontrivial representations (note that  $V_{\widehat{\text{iso}}-1}$  is not itself a vector bundle), and for a map of vector bundles  $f$ , we denote by  $f_{\widehat{\text{iso}}-1}$  its action on these subspaces. Given a vector bundle  $V$  over an orbifold  $X$  together with a map  $\alpha: TX \rightarrow V$  for which  $\alpha_{\widehat{\text{iso}}-1}$  is surjective, a section  $s: X \rightarrow V$  is called  $\alpha$ -consistently transverse (to zero) if and only if over its zero set  $ds$  is surjective with  $(ds)_{\widehat{\text{iso}}-1} = \alpha_{\widehat{\text{iso}}-1}$ .

**Theorem 5.7** (Wasserman [38]) *Let  $X$  be an orbifold, let  $E$  be a vector bundle over  $X$  and fix a map  $\alpha: TX \rightarrow E$  for which  $\alpha_{\widehat{\text{iso}}-1}$  is surjective. Every section of  $E$  has a  $C^0$ -small perturbation which is  $\alpha$ -consistently transverse. This perturbation may be taken relative to a neighborhood of any closed set over which it is already  $\alpha$ -consistently transverse.*

(We credit this result to Wasserman [38], although Wasserman only stated the special case that  $X = \mathbb{R}^n/G$  and  $E$  is the descent of the trivial bundle  $\mathbb{R}^n$  with the same  $G$ -action, and  $\alpha$  is the identity.)

**Proof** We proceed by induction over the stratification of  $X$  by order of stabilizer. By triangulating a given stratum, it suffices to perturb on any given disk rel boundary

inside  $X$ , which all have a standard local model. In other words, it suffices to consider the case of  $X = D^k \times D^\ell \times W/G$ , where  $G \curvearrowright W$  has zero invariant part  $W^G = 0$ , the section  $s$  is  $\alpha$ -consistently transverse over a neighborhood of  $\partial D^k \times 0 \times 0$ , and we would like to make it  $\alpha$ -consistently transverse over a neighborhood of  $D^k \times 0 \times 0$ . Now over  $D^k \times 0 \times 0$ , the derivative  $ds$  is  $G$ -equivariant, hence respects the decomposition into isotypic pieces:

$$(5-19) \quad (ds)_1 \oplus (ds)_{\widehat{G}_{-1}}: (TD^k \oplus TD^\ell) \oplus W \rightarrow E^G \oplus E_{\widehat{G}_{-1}}.$$

By perturbing (rel a neighborhood of the boundary) the restriction of  $s$  to  $D^k \times 0 \times 0$ , we may make  $(ds)_1$  surjective; note that  $s$  is constrained to land inside  $E^G$  over  $D^k \times 0 \times 0$ . We may then extend  $s$  to a neighborhood of  $D^k \times 0 \times 0$  so that  $(ds)_{\widehat{G}_{-1}} = \alpha_{\widehat{G}_{-1}}$  over  $D^k \times 0 \times 0$ .

We are not quite done, however, since the above construction ensures that our perturbed section  $s$  will be  $\alpha$ -consistently transverse over  $D^k \times 0 \times 0$  and a neighborhood of  $\partial D^k \times 0 \times 0$ , but not over a neighborhood of  $D^k \times 0 \times 0$ . To fix this, choose an isomorphism  $E = \pi^* E$ , where  $\pi$  denotes the projection  $\pi: D^k \times D^\ell \times W/G \rightarrow D^k \times D^\ell$  forgetting the last coordinate. Now given the section  $s$  defined above, set

$$(5-20) \quad \bar{s}(a, b, c) := s(a, b, 0) + \alpha_{\widehat{G}_{-1}}(c),$$

where we use the isomorphism  $E = \pi^* E$  to make sense of the right-hand side as an element of the fiber of  $E$  over  $(a, b, c) \in D^k \times D^\ell \times W/G$ . Now this section  $\bar{s}$  is certainly  $\alpha$ -consistently transverse over a neighborhood of  $D^k \times 0 \times 0$ , however it does not agree with  $s$  over a neighborhood of  $\partial D^k \times 0 \times 0$ . Instead, let us use  $\varphi \cdot \bar{s} + (1 - \varphi) \cdot s$  for a smooth function  $\varphi: D^k \rightarrow [0, 1]$  vanishing near  $\partial D^k$  and which equals 1 over a large compact set. This interpolation is now  $\alpha$ -consistently transverse over a neighborhood of  $D^k \times 0 \times 0$ , noting that the restriction of  $d\varphi$  to the  $(\cdot)_{\widehat{\text{iso}}_{-1}}$  part of the tangent bundle is zero.  $\square$

**Remark 5.8** A stable homotopy theoretic analogue of this argument appears in tom Dieck [12, Satz 5] and Schwede [34, Theorem 6.2.33]. It would be interesting to explore whether a stable homotopy theoretic analogue of Fukaya and Ono's "integer part" construction [17] exists as well; that construction follows a strategy similar to Wasserman's strategy above, though rather than using  $\alpha$  in the normal directions, one requires complex polynomial behavior in the normal directions.

**Corollary 5.9** *A derived orbifold chart whose tangent bundle is stably isomorphic to a coarsely stable vector bundle is bordant to an orbifold.*



**Proof** Let  $Z = (D, E, s)$  be a derived orbifold chart. By assumption, the stable vector bundle  $TD - E$  is stably isomorphic to a coarsely stable vector bundle  $F - \mathbb{R}^N$  — in fact, we will not use anything special about  $\mathbb{R}^N$  other than that it is coarse. In other words, there exists a vector bundle  $V$  and an isomorphism  $TD \oplus V \oplus \mathbb{R}^N = E \oplus V \oplus F$ . By stabilizing our derived orbifold chart  $(D, E, s)$  by  $V$ , we may reduce this to  $TD \oplus \mathbb{R}^N = E \oplus F$ . Now the composition  $\alpha: TD \rightarrow TD \oplus \mathbb{R}^N = E \oplus F \rightarrow E$  is evidently surjective on  $(\cdot)_{\text{iso}-1}$  pieces. We can thus apply Wasserman (Theorem 5.7) to perturb  $s$  to a section  $s'$  which is transverse to zero (and agrees with  $s$  outside a compact set). The desired bordism is thus  $(D \times [0, 1], E \times [0, 1], ts + (1 - t)s')$ .  $\square$

The literal converse to Corollary 5.9 is false for trivial reasons —  $\partial[0, 1]$  times anything is nullbordant yet need not have coarsely stable tangent bundle. The next subsection formulates an “up to bordism” version of Corollary 5.9 which is an “if and only if” (or rather isomorphism) statement.

### 5.5 Orbifold bordism as oriented derived orbifold bordism

Let us now explain how Wasserman’s theorem implies, as one might expect after seeing Corollary 5.9, that orbifold bordism may be expressed as derived orbifold bordism with a sort of tangential structure, namely what we will call a *coarsely stable structure* on its stable tangent bundle. We may thus think of  $\Omega_*$  as an “oriented” version of  $\Omega_*^{\text{der}}$ , in the sense that modifying the definition of  $\Omega_*^{\text{der}}$  by imposing a marking on the stable tangent bundle yields  $\Omega_*$ .

A *coarsely stable structure* on a stable vector bundle  $V$  is a coarsely stable vector bundle  $W$  and a stable isomorphism  $V = W$ . A given stable vector bundle may admit multiple nonisomorphic coarsely stable structures (nonisomorphic coarsely stable vector bundles may be stably isomorphic).

Derived orbifold bordism with coarsely stable tangential structure  $\Omega_*^{\text{st,der}}$  is defined as follows. Consider derived orbifold charts  $Z = (D, E, s)$  representable over  $(X, A)$  together with a vector bundle  $A$  and a stable isomorphism  $A - \mathbb{R}^{|E| - |TD| - |A|} = TD - E$ , modulo restriction, stabilization,  $A \mapsto A \oplus \mathbb{R}$  and bordism. Let us argue that bordism after restriction, stabilization and  $A \mapsto A \oplus \mathbb{R}$  is transitive, and hence is an equivalence relation. As argued in the proof of Proposition 5.1, given two bordisms  $C_{12}$  and  $C_{23}$ , we may stabilize so that the requisite stabilizations of  $Z_2$  coincide. The bordisms may thus be glued, so it suffices to argue that the coarsely stable structures can also be glued.

We have vector bundles  $A_{12}$  on  $C_{12}$  and  $A_{23}$  on  $C_{23}$  and a coarsely stable isomorphism between their restrictions to  $Z_2$ . Thus, stabilizing  $A_{12}$  and  $A_{23}$  by adding  $\underline{\mathbb{R}}^k$ , we get a genuine isomorphism on  $Z_2$ , which allows us to glue them together. Now we have stable isomorphisms between this glued coarsely stable vector bundle and the tangent space to our glued derived bordism, separately on  $C_{12}$  and  $C_{23}$ , and their restrictions to  $Z_2$  are homotopic. They may thus be glued (nonuniquely). We conclude that bordism after restriction, stabilization and  $A \mapsto A \oplus \underline{\mathbb{R}}$  is an equivalence relation, as desired.

**Remark 5.10** One can similarly define a theory  $\Omega_*^{-\text{cst,der}}$  of bordism of derived orbifolds with coarsely stable structure on minus their tangent bundle.

Given that bordism after restriction, stabilization and  $A \mapsto A \oplus \underline{\mathbb{R}}$  is an equivalence relation, the proof of Proposition 5.3 now applies to show that  $\Omega_*^{\text{cst,der}}: \text{OrbSpc}_* \rightarrow \text{Ab}$  sends cofiber sequences to exact sequences.

**Proposition 5.11** *The natural map  $\Omega_* \xrightarrow{\sim} \Omega_*^{\text{cst,der}}$  is an isomorphism.*

**Proof** Surjectivity is the statement that every derived orbifold chart  $(D, E, s)$  with coarsely stable vector bundle  $\xi$  and stable isomorphism  $\xi = TD - E$  is bordant to an orbifold, ie a derived orbifold chart whose obstruction section is transverse. Corollary 5.9 provides a transverse perturbation of  $s$  which, executed over  $[0, 1]$ , defines the desired bordism.

Injectivity is (given the nontrivial result, proved just above, that derived bordism with coarsely stable tangential structure is an equivalence relation) the statement that every derived orbifold bordism between stabilizations of orbifolds, with coarsely stable structure on its tangent bundle, agreeing with the tautological such on the boundary, can be perturbed rel boundary to be transverse. Concretely, such a structure is (after stabilizing as in the proof of Corollary 5.9) a vector bundle  $F$  and an isomorphism  $F \oplus E = TD \oplus \underline{\mathbb{R}}^k$ , which on the boundary must coincide with the isomorphism  $E = TD$  given by  $ds$  and  $F = \underline{\mathbb{R}}^k$  (some isomorphism); thus  $s$  is already  $\alpha$ -transverse over the boundary, so the relative form of Wasserman's Theorem 5.7 gives us what we want.  $\square$

The theory  $\Omega_*^{\text{cst,der}}$  may be twisted: for any stable vector bundle  $\xi$  on  $X$ , we may define a group  $\Omega_*^{\xi \oplus \text{cst,der}}(X, A)$  of bordism classes of derived orbifolds carrying a coarsely

stable vector bundle  $W$  and an isomorphism  $TD - E = \xi \oplus W$ . These twisted theories are the natural setting for inverse Thom maps

$$(5-21) \quad \Omega_*^{\xi \oplus \text{cst,der}}(X, A) \rightarrow \Omega_{*+|V|}^{\xi \oplus V \oplus \text{cst,der}}((X, A)^V).$$

Now there is an obvious Thom map in the reverse direction — add  $V$  to the obstruction space and the identity map to the obstruction section — which is an inverse to the inverse Thom map exactly as in Proposition 5.5. There are also forgetful maps

$$(5-22) \quad \Omega_*^{\xi \oplus V \oplus \text{cst,der}}(X, A) \rightarrow \Omega_*^{\xi \oplus \text{cst,der}}(X, A)$$

for vector bundles  $V$ , which need not be isomorphisms. This refines the discussion of inverse Thom maps for  $\Omega_*$  given above.

The Thom isomorphism for these twisted theories allows us to extend  $\Omega_* = \Omega_*^{\text{cst,der}}$  to genuine orbispectra by defining

$$\Omega_*((X, A)^{-V}) = \Omega_*^{\text{cst,der}}((X, A)^{-V}) := \Omega_{*+|V|}^{V \oplus \text{cst,der}}(X, A).$$

To check that this indeed defines a functor  $\text{RepOrbSp}^f \rightarrow \text{Ab}$ , use the localization result Proposition 3.33 and the twisted Thom isomorphism. Indeed, the definition above gives a functor out of the direct limit of  $\text{RepOrbSpc}_{N,k}$  (by the Thom isomorphism), and it satisfies excision (by inspection), thus descending to  $\text{RepOrbSp}^f$ . This functor sends cofiber sequences to exact sequences; the proof for twisted  $\Omega_*^{\text{cst,der}}$  is the same as for untwisted, which was already mentioned above.

### 5.6 Tangential structure

We define orbifold and derived orbifold bordism groups with tangential structure, and we show how to generalize the basic properties proven above to this setting. In a word, a structure on vector bundles  $\mathfrak{S}$  with a shift allows us to define orbifold bordism groups  $\Omega_*^{\mathfrak{S}}$ , and a stable structure on vector bundles  $\mathfrak{S}$  allows us to define derived orbifold bordism groups  $\Omega_*^{\mathfrak{S},\text{der}}$ .

For  $\mathfrak{S}$  a structure on vector bundles with a shift, we define bordism groups  $\Omega_*^{\mathfrak{S}}$  as follows. We consider orbifolds with coarsely stable  $\mathfrak{S}$ -structure on their tangent bundle. Using the isomorphism  $\text{Str}_{\mathfrak{S}}^{\text{cst}}(V) = \text{Str}_{\mathfrak{S}}^{\text{cst}}(V \oplus \mathbb{R})$ , we can define a notion of bordism of orbifolds with coarsely stable  $\mathfrak{S}$ -structure: given a boundary marking  $Z_0 \sqcup Z_1 \subseteq \partial W$ , we use the isomorphisms  $\text{Str}_{\mathfrak{S}}^{\text{cst}}(TZ_i) = \text{Str}_{\mathfrak{S}}^{\text{cst}}(TZ_i \oplus \mathbb{R}) = \text{Str}_{\mathfrak{S}}^{\text{cst}}(TW|_{Z_i})$  — where, crucially, we identify  $\mathbb{R}$  with the inward normal along  $Z_0$  and the outward normal along  $Z_1$  — to require compatibility between the coarsely stable  $\mathfrak{S}$ -structure on  $W$  with

those on  $Z_0$  and  $Z_1$ . Bordism is a symmetric relation, as can be seen by inverting the coarsely stable structure on the bordism, ie applying the canonical involution of  $\text{Str}_{\mathfrak{S}}^{\text{cst}}$ . It is transitive since coarsely stable  $\mathfrak{S}$ -structures glue: by applying  $\oplus \mathbb{R}^k$  enough times, we reduce to gluing for  $\mathfrak{S}$ -structures; an  $\mathfrak{S}$ -structure over  $C_{12}$  and one over  $C_{23}$  which are homotopic over  $Z_2$  glue, nonuniquely, to an  $\mathfrak{S}$ -structure over  $C_{12} \cup_{Z_2} C_{23}$ . The resulting  $\mathfrak{S}$ -bordism groups  $\Omega_*^{\mathfrak{S}}$  satisfy functoriality (including excision) and exactness by the same reasoning as before. They have inverse Thom maps

$$(5-23) \quad \Omega_*^{\mathfrak{S}}(X, A) \rightarrow \Omega_{*+1}^{\mathfrak{S}}((X, A) \times (I, \partial I)),$$

and Thom maps in the reverse direction which are inverse to the inverse Thom maps; this extends  $\Omega_*^{\mathfrak{S}}$  to a functor on naive orbispectra. As before, we may extend  $\Omega_*^{\mathfrak{S}}$  to genuine orbispectra by viewing it as a structured version of derived orbifold bordism. Namely,  $\Omega_*^{\mathfrak{S}}$  coincides with the group  $\Omega_*^{\mathfrak{S}\text{cst,der}}$  of bordism classes of derived orbifold charts carrying a coarsely stable vector bundle  $A$  with isomorphism  $A = TD - E$  and a coarsely stable  $\mathfrak{S}$ -structure on  $A$ . These groups  $\Omega_*^{\mathfrak{S}\text{cst,der}}$  satisfy the same properties as above, and the map  $\Omega_*^{\mathfrak{S}} \rightarrow \Omega_*^{\mathfrak{S}\text{cst,der}}$  is an isomorphism. There are also twisted versions  $\Omega_*^{\xi \oplus \mathfrak{S}\text{cst,der}}(X, A)$  for any stable vector bundle  $\xi$  on  $X$ , and there are inverse Thom maps

$$\Omega_*^{\xi \oplus \mathfrak{S}\text{cst,der}}(X, A) \rightarrow \Omega_{*+|\xi|}^{\xi \oplus V \oplus \mathfrak{S}\text{cst,der}}((X, A)^V)$$

and forgetful maps

$$\Omega_*^{\xi \oplus V \oplus \mathfrak{S}\text{cst,der}} \rightarrow \Omega_*^{\xi \oplus \mathfrak{S}\text{cst,der}}$$

for any vector bundle  $V$  with coarsely stable structure. We may thus extend  $\Omega_*^{\mathfrak{S}}$  to genuine orbispectra by taking  $\Omega_*^{\mathfrak{S}}((X, A)^{-\xi}) := \Omega_{*+|\xi|}^{\xi \oplus \mathfrak{S}\text{cst,der}}(X, A)$ .

Now suppose  $\mathfrak{S}$  is a stable structure on vector bundles, and let us define derived  $\mathfrak{S}$ -orbifold bordism. We consider derived orbifold charts  $(D, E, s)$  together with a stable  $\mathfrak{S}$ -structure on  $TD - E$ , modulo restriction, stabilization and bordism as before. The equivalence relation proof of Proposition 5.1 applies; for this, we need to know that stable structures on vector bundles glue, and the main point to see that is to use enough vector bundles to know that we can stabilize by vector bundles on  $C_{12} \cup_{Z_2} C_{23}$  to reduce to gluing (again, nonuniquely)  $\mathfrak{S}$ -structures on  $C_{12}$  and  $C_{23}$  which agree over  $Z_2$ . The resulting theory thus satisfies exactness. These theories can be twisted: we may define  $\Omega_*^{V \oplus \mathfrak{S}, \text{der}}(X, A)$  to be bordism classes of derived orbifold charts with a stable  $\mathfrak{S}$ -structure on  $TD - E - V$ , where  $V$  is any stable vector bundle on  $X$ ; an  $\mathfrak{S}$ -structure on  $V$  gives an isomorphism  $\Omega_*^{V \oplus \mathfrak{S}, \text{der}}(X, A) = \Omega_*^{\mathfrak{S}, \text{der}}(X, A)$ . Inverse Thom maps

for  $\Omega_*^{\mathfrak{S},\text{der}}$  now take the form

$$(5-24) \quad \Omega_*^{\xi \oplus \mathfrak{S},\text{der}}(X, A) \rightarrow \Omega_{*+|V|}^{\xi \oplus V \oplus \mathfrak{S},\text{der}}((X, A)^V),$$

and there are also Thom maps which are inverse to these. We may thus extend  $\Omega_*^{\mathfrak{S},\text{der}}$  to orbispectra as  $\Omega_*^{\mathfrak{S},\text{der}}((X, A)^{-\xi}) := \Omega_{*+|\xi|}^{\xi + \mathfrak{S},\text{der}}(X, A)$ . The natural map

$$(5-25) \quad \varinjlim_W \Omega_{*+|W|}^{\mathfrak{S}}((X, A)^W) \rightarrow \varinjlim_W \Omega_{*+|W|}^{\mathfrak{S},\text{der}}((X, A)^W) = \Omega_*^{\mathfrak{S},\text{der}}(X, A)$$

is an isomorphism, where the direct limit is over all vector bundles with  $\mathfrak{S}$ -structure as in (4-5). There are also graded symmetric product maps on  $\Omega_*^{\mathfrak{S}}$  and  $\Omega_*^{\mathfrak{S},\text{der}}$ .

### 5.7 Fundamental classes

We make a few remarks about fundamental classes of orbifolds and derived orbifolds.

A closed orbifold  $M$  has a tautological fundamental class  $[M] \in \Omega_{\dim M}(M)$ . This class is best viewed as arising from the more refined fundamental class  $[M] \in \Omega_0^{\text{fr}}(M^{-TM})$  lying in the bordism group of derived orbifolds representable over  $M$  with a stable isomorphism between their tangent bundle and  $TM$ . This class may be pushed forward under the map  $\Omega_0^{\text{fr}}(M^{-TM}) \rightarrow \Omega_0(M^{-TM})$  forgetting the framing and under the inverse Thom map  $\Omega_0(M^{-TM}) \rightarrow \Omega_{\dim M}(M)$ , to obtain the naive fundamental class  $[M] \in \Omega_{\dim M}(M)$ . If  $TM$  is equipped with an  $\mathfrak{S}$ -structure, then we may push forward to  $\Omega_{\dim M}^{\mathfrak{S}}(M)$  using the  $\mathfrak{S}$ -structured inverse Thom map to obtain the  $\mathfrak{S}$ -structured fundamental class. The same applies when  $M$  is a compact orbifold with boundary, just replacing  $M$  with the pair  $(M, \partial M)$ .

Let us now work towards the fundamental class of a derived orbifold. Consider an inclusion of subcomplexes  $(Y, B) \rightarrow (X, A)$  (so  $B = Y \cap A$ ) and a vector bundle  $E$  over  $X$  with a section  $s: X \rightarrow E$  whose zero set is (contained in)  $Y$ . There is then an induced map  $(X, A) \rightarrow (Y, B)^E$ , obtained by appealing to the fact that  $(Y, B) \subseteq (X, A)$  is a retract of any sufficiently small neighborhood, and any two such retracts are homotopic. Thus if  $(D, E, s)$  is a derived orbifold chart and  $Z := s^{-1}(0)$  has the same neighborhood retract property, we obtain a map

$$(5-26) \quad (D, \partial D)^{-TD} \rightarrow (Z, \partial Z)^{-TZ},$$

where  $TZ := TD - E$ ,  $\partial Z := Z \cap \partial D$  and  $\dim Z := \dim D - \dim E$ ; note that whereas the left side is the dual of  $D$ , the right side is very much *not* the dual of  $Z$  unless  $s$  is transverse to zero. We may now define  $[Z] \in \Omega_0^{\text{fr}}((Z, \partial Z)^{-TZ})$  as the image of  $[D]$  under the above map. Since  $TZ$  is not a vector bundle, but only a stable vector bundle,

we are no longer able to map this fundamental class to  $\Omega_{\dim Z}(Z, \partial Z)$ , rather only to  $\Omega_{\dim Z}^{\text{der}}(Z, \partial Z)$ ; the map now involves the inverse of an inverse Thom map, which only exists for  $\Omega_{*}^{\text{der}}$ . If  $TZ$  is equipped with a stable  $\mathfrak{S}$ -structure, then we can also push forward the fundamental class to  $\Omega_{\dim Z}^{\mathfrak{S}, \text{der}}(Z, \partial Z)$ .

If our derived orbifold  $Z \subseteq D$  does not have the neighborhood retract property, the above reasoning produces only a class in the inverse limit  $\varprojlim_{\varepsilon > 0} \Omega_0^{\text{fr}}((Z_\varepsilon, \partial Z_\varepsilon)^{-TZ})$ , where  $Z_\varepsilon \subseteq D$  denotes the  $\varepsilon$ -neighborhood of  $Z$ . This is not really the correct bordism group to associate to  $(Z, \partial Z)^{-TZ}$ , rather differing from it by a  $\varprojlim^1$  term. In the correct bordism group to attach to it, a cycle would be a collection of (derived, with structure) orbifolds  $(M_{\varepsilon_i}, \partial M_{\varepsilon_i}) \rightarrow (Z_{\varepsilon_i}, \partial Z_{\varepsilon_i})$  together with bordisms between  $M_{\varepsilon_i}$  and  $M_{\varepsilon_{i+1}}$  over  $Z_{\varepsilon_i}$  (fixing some sequence  $\varepsilon_1 > \varepsilon_2 > \dots$  converging to zero).

## 6 Global homotopy theory

This section shows one way to connect the homotopy theory of orbispaces developed thus far and *global homotopy theory*. We prove only what we need for the Pontryagin–Thom isomorphism; there is yet much to be worked out. We refer to the treatment by Schwede [34] for the foundations of global homotopy theory. Global homotopy theory depends on a choice of set  $\mathcal{F}$  of isomorphism classes of compact Lie groups; we will always take this set be the class of finite groups, and it will not be mentioned further.

### 6.1 Global spaces

Here we relate the category  $\text{OrbSpc}$  with the global homotopy category  $\text{GloSpc}$ , whose objects we call *global spaces*.

Let  $\mathbb{L}$  denote the topological category of finite-dimensional real vector spaces with a positive definite inner product and linear isometric (in particular, injective) maps. An *orthogonal space* is a continuous functor  $F: \mathbb{L} \rightarrow \mathbf{kTop}$ , where  $\mathbf{kTop}$  is the category of  $k$ -spaces<sup>1</sup> [34, Definition 1.1.1]. In other words, it is the assignment to each  $V \in \mathbb{L}$  of a  $k$ -space  $F(V)$  and to each pair  $V, W \in \mathbb{L}$  a continuous map  $F(V) \times \mathbb{L}(V, W) \rightarrow F(W)$ , such that this rule is compatible with composition for triples  $V, W, U \in \mathbb{L}$ . The category of orthogonal spaces is denoted by  $\text{OrthSpc}$ .

<sup>1</sup>A  $k$ -space is a topological space which is compactly generated and weakly Hausdorff.

A map of orthogonal spaces  $F \rightarrow F'$  is called a *global equivalence* if and only if for every finite group  $G$ , every orthogonal  $G$ -representation  $V$  and every diagram of solid arrows

$$(6-1) \quad \begin{array}{ccccc} \partial D^k & \longrightarrow & F(V)^G & \dashrightarrow & F(W)^G \\ \downarrow & & \downarrow & \nearrow & \downarrow \\ D^k & \longrightarrow & F'(V)^G & \dashrightarrow & F'(W)^G \end{array}$$

there exists an orthogonal  $G$ -representation  $W$  and an inclusion  $V \hookrightarrow W$  such that after pushing forward under it, the bottom map  $D^k \rightarrow F'(W)^G$  above may be homotoped rel boundary so as to lift to  $F(W)^G$ ; see [34, Definition 1.1.2]. The category of global spaces  $\text{GloSpc}$  is the localization of the category of orthogonal spaces  $\text{OrthSpc}$  at the global equivalences. (There is a model structure on  $\text{OrthSpc}$  whose weak equivalences are the global equivalences, giving an effective way to understand the localization  $\text{GloSpc}$ ; see [34, Section 1.2].)

An orthogonal space gives rise, in particular, to a representable map

$$\bigsqcup_{n \geq 0} F(\mathbb{R}^n)/O(n) \rightarrow \bigsqcup_{n \geq 0} */O(n).$$

Thus for any vector bundle  $V$  with inner product over a stack  $X$ , we may pull back under the classifying map to obtain a representable map  $F(V) \rightarrow X$ . Moreover, for any isometric inclusion  $V \hookrightarrow W$  of vector bundles with inner product, we get a map  $F(V) \rightarrow F(W)$  over  $X$ . Denote by  $\text{Vect}^O(X)$  the category of vector bundles with inner product on  $X$  and homotopy classes of injective isometric maps; this category is filtered. There is thus a directed system over  $\text{Vect}^O(X)$  assigning to a vector bundle  $V$  the set of homotopy classes of sections of  $F(V) \rightarrow X$ . Note that the forgetful functor  $\text{Vect}^O(X) \rightarrow \text{Vect}(X)$  is an equivalence, due to Lemma 2.6 and the deformation retraction from injections to isometric injections given by  $f \mapsto f(f^*f)^{-t/2}$ . Therefore in the event that the orthogonal space  $F$  is pulled back from the category of finite-dimensional vector spaces and injective maps, we may simply take the direct limit over  $\text{Vect}(X)$  and forget about inner products.

Given a finite orbi-CW-complex  $X$  and an orthogonal space  $F$ , let  $\text{Hom}(X, F)$  denote the direct limit over  $V \in \text{Vect}^O(X)$  of homotopy classes of sections of  $F(V) \rightarrow X$ . This set  $\text{Hom}(X, F)$  is functorial in  $X$  (pull back vector bundles) and in  $F$ . This is only a reasonable definition because of enough vector bundles; in particular, enough vector bundles is used crucially in the following proof that maps from a finite orbi-CW-complex to an orthogonal space descend to a functor  $(\text{OrbSpc}^f)^{\text{op}} \times \text{GloSpc} \rightarrow \text{Set}$ .

**Lemma 6.1** *For a finite orbi-CW-complex and a global equivalence of orthogonal spaces  $F \rightarrow F'$ , the induced map  $\text{Hom}(X, F) \rightarrow \text{Hom}(X, F')$  is a bijection.*

**Proof** Let  $V$  be a vector bundle with inner product over  $X$ , let a section of  $F'(V) \rightarrow X$  be given, and let us lift it (up to homotopy) to  $(F)$ , after possibly enlarging  $V$ . Since  $X$  is finite, it suffices to do this lifting cell by cell. So, fix a cell  $(D^k, \partial D^k) \times \mathbf{BG}$  of  $X$ . The pullback of  $V$  to this cell is classified by a map  $D^k \times \mathbf{BG} \rightarrow \bigsqcup_{n \geq 0} */O(n)$ , which up to homotopy (hence isomorphism by Lemma 2.7) factors through  $\mathbf{BG} \rightarrow \bigsqcup_{n \geq 0} */O(n)$ , which is an orthogonal  $G$ -representation  $V_0$ . Now the section of  $F'(V) \rightarrow X$  pulled back from  $D^k \times \mathbf{BG}$  is a map  $D^k \rightarrow F'(V_0)^G$ , which over  $\partial D^k$  we have lifted to  $F(V_0)^G$ . We are thus in exactly the situation of the solid arrows in (6-1), so we conclude that there exists another orthogonal  $G$ -representation  $W_0$  and an embedding  $V_0 \hookrightarrow W_0$  such that the desired lift exists over  $D^k \times \mathbf{BG}$  after pushing forward to  $W_0$ . Now by enough vector bundles (Theorem 3.23), there exists a  $W'$  on  $X$  and an embedding  $V \hookrightarrow W'$  which over  $D^k \times \mathbf{BG}$  factors through  $V_0 \hookrightarrow W_0 \hookrightarrow W'_0$ .  $\square$

There is much more to this story; however, further precise discussion would take us too far afield. There is a functor

$$(6-2) \quad \text{OrbSpc}^f \rightarrow \text{GloSpc},$$

$$(6-3) \quad X \mapsto \text{Emb}_X(E, -) \quad \text{with } E/X \text{ faithful},$$

where  $\text{Emb}_X(E, V)$  denotes the total space of the fibration over  $X$  whose fiber over  $x \in X$  is the space of embeddings  $\text{Emb}(E_x, V)$  — this is a space since  $E$  is faithful. The spaces  $\text{Emb}_X(E, -)$  form an inverse system on the category of vector bundles on  $X$ , and for an inclusion of faithful vector bundles  $E \hookrightarrow E'$ , the induced map  $\text{Emb}_X(E', -) \rightarrow \text{Emb}_X(E, -)$  is a global equivalence [34, Proposition 1.1.26(ii) and Definition 1.1.27]. A map of orbispaces  $f: X \rightarrow Y$  induces maps  $\text{Emb}_X(f^*E_Y, -) \rightarrow \text{Emb}_Y(E_Y, -)$  for any vector bundle  $E_Y$  over  $Y$ . Taking  $E_Y$  to be faithful and choosing an embedding of  $f^*E_Y$  into a faithful  $E_X$ , we obtain a map

$$\text{Emb}_X(E_X, -) \rightarrow \text{Emb}_X(f^*E_Y, -) \rightarrow \text{Emb}_Y(E_Y, -).$$

**Conjecture 6.2** For  $X \in \text{OrbSpc}^f$  and  $F \in \text{GloSpc}$ , the set  $\text{Hom}(X, F)$  coincides with the morphisms from the image of  $X$  under (6-2) to  $F$ .

**Conjecture 6.3** The functor (6-2) is fully faithful.



Schwede [35] has shown that  $\text{GloSpc}$  is equivalent to  $\text{PSh}(\{\mathbf{BG}\})$ , where  $\{\mathbf{BG}\} \subseteq \text{OrbSpc}$  is the full subcategory spanned by the objects  $\{\mathbf{BG}\}$ ,<sup>2</sup> and in [18] Gepner and Henriques have defined via stacks a natural enlargement  $\overline{\text{OrbSpc}}$  of  $\text{OrbSpc}$ , resulting from gluing together cells  $(D^k, \partial D^k) \times \mathbf{BG}$  under arbitrary maps, and shown that the natural map  $\overline{\text{OrbSpc}} \rightarrow \text{PSh}(\{\mathbf{BG}\})$  is an equivalence. Together this defines an equivalence  $\overline{\text{OrbSpc}} = \text{GloSpc}$ .

**Conjecture 6.4** The restriction of the equivalence  $\overline{\text{OrbSpc}} = \text{GloSpc}$  from [18; 35] to the full subcategory  $\text{OrbSpc} \subseteq \overline{\text{OrbSpc}}$  coincides with the functor (6-2).

### 6.2 Global classifying spaces

We now recall various “global classifying spaces” from [34].

For any compact Lie group  $G$ , there is a “global classifying space”  $\mathbf{BG} \in \text{GloSpc}$ ; see [34, Definition 1.1.27], note that there it is denoted by  $B_{\text{gl}}G$ . It is represented by the orthogonal space

$$(6-4) \quad (\mathbf{BG})(V) := \text{Emb}(E, V)/G$$

for any faithful  $G$ -representation  $E$ . In particular, when  $G = O(n)$ , it is natural to take the defining representation  $O(n) \curvearrowright \mathbb{R}^n$ , so we get

$$(6-5) \quad (\mathbf{BO}(n))(V) := \text{Gr}_n(V).$$

Also, when  $G$  is finite,  $\mathbf{BG} \in \text{GloSpc}$  is the image of  $\mathbf{BG} \in \text{OrbSpc}$  under (6-2).

Let us see that the global space  $\mathbf{BG}$  represents the functor of  $G$ -bundles on finite orbi-CW-complexes. Maps from a finite orbi-CW-complex  $X$  to  $\mathbf{BG}$  is the direct limit over  $V/X$  of the space of embeddings of  $E$  into  $V$  modulo  $G$ , where  $G \curvearrowright E$  is a faithful representation. Denoting by  $\text{Emb}_X(E, V)$  the total space over  $X$ , we note that  $\text{Emb}_X(E, V) \rightarrow \text{Emb}_X(E, V)/G$  is a principal  $G$ -bundle, so any section of  $\text{Emb}_X(E, V)/G \rightarrow X$  gives via pullback a principal  $G$ -bundle over  $X$ . Conversely, given a principal  $G$ -bundle  $P \rightarrow X$ , a section of  $\text{Emb}_X(E, V)/G$  together with an isomorphism between the resulting pullback bundle and  $P \rightarrow X$  is the same as an embedding  $E \times_G P \hookrightarrow V$ , and the space of such embeddings becomes contractible in the direct limit over  $V$ .

**Conjecture 6.5** The functor (6-2) sends  $\mathbf{BG} \in \text{OrbSpc}$  to  $\mathbf{BG} \in \text{GloSpc}$ .

<sup>2</sup>This result requires a homotopical categorical context such as model categories or  $\infty$ -categories.

There are two natural global spaces  $\mathbf{bO}$  and  $\mathbf{BO}$  which generalize the classifying space  $BO := \varinjlim_n BO(n)$ . The global space  $\mathbf{bO}$  [34, Example 2.4.18] is given by the orthogonal space

$$(6-6) \quad \mathbf{bO}(V) := \mathrm{Gr}_{|V|}(V \oplus \mathbb{R}^\infty),$$

in which to a map  $V \hookrightarrow W$  we associate the map

$$(6-7) \quad \mathrm{Gr}_{|V|}(V \oplus \mathbb{R}^\infty) \xrightarrow{\oplus(W/V)} \mathrm{Gr}_{|W|}(W \oplus \mathbb{R}^\infty).$$

The global space  $\mathbf{bO}$  is the direct limit of  $\mathbf{BO}(n) \in \mathrm{GloSpc}$  [34, Proposition 2.4.24].

Let us argue that  $\mathbf{bO}$  classifies coarsely stable vector bundles of rank zero. Maps from a finite orbi-CW-complex  $X$  to  $\mathbf{bO}$  are given by the direct limit over all vector bundles  $E$  over  $X$  of global sections of  $\mathrm{Gr}_{|E|}(E \oplus \mathbb{R}^\infty)$ . We may express this as the direct limit over both  $n$  and  $E$  of subbundles of rank  $|E|$  of  $E \oplus \mathbb{R}^n$ . Equivalently, this is quotient bundles of  $E \oplus \mathbb{R}^n$  of rank  $n$ . Now taking the direct limit over  $E$ , we realize every vector bundle has a homotopically unique surjection from  $E \oplus \mathbb{R}^n$  in the direct limit over  $E$ . Thus what remains is the direct limit over  $n$  of vector bundles over  $X$ , with passage from  $n$  to  $n+1$  acting as  $\oplus \mathbb{R}$ . This is precisely rank-zero coarsely stable vector bundles over  $X$ .

**Conjecture 6.6** The functor (6-2) sends  $\mathbf{bO} \in \mathrm{OrbSpc}$  to  $\mathbf{bO} \in \mathrm{GloSpc}$ .

The global space  $\mathbf{BO}$  [34, Example 2.4.1] is defined as the orthogonal space

$$(6-8) \quad \mathbf{BO}(V) := \mathrm{Gr}_{|V|}(V \oplus V),$$

in which to a map  $V \hookrightarrow W$  we associate the map

$$(6-9) \quad \mathrm{Gr}_{|V|}(V \oplus V) \rightarrow \mathrm{Gr}_{|V|}(W \oplus V) \xrightarrow{\oplus(W/V)} \mathrm{Gr}_{|W|}(W \oplus W).$$

We argue that  $\mathbf{BO} \in \mathrm{GloSpc}$  classifies stable vector bundles of rank zero; recall from Lemma 4.7 that there is no  $\mathbf{BO} \in \mathrm{OrbSpc}$  with this property. Maps from a finite orbi-CW-complex  $X$  to  $\mathbf{BO}$  are the direct limit over  $E/X$  of subbundles of rank  $|E|$  of  $E \oplus E$ . Let us choose to view this as the direct limit over pairs of vector bundles  $E$  and  $E'$  of subbundles of rank  $|E|$  of  $E \oplus E'$ . Taking the direct limit over  $E'$ , we see that this is just vector bundles of rank  $|E|$  on  $X$ , and that in the remaining directed system over  $E$ , when going from  $E_1$  to  $E_2$ , we add  $E_2/E_1$ . Thus we get precisely rank-zero stable vector bundles over  $X$ .

### 6.3 Global spectra

Here we relate the category  $\text{OrbSp}^f$  with the global stable homotopy category  $\text{GloSp}$ , whose objects we call *global spectra*.

Let  $\mathbb{O}$  denote the based topological category with the same objects as  $\mathbb{L}$  and with morphism space from  $V$  to  $W$  given by the Thom space of (ie the one-point compactification of the total space of) the tautological vector bundle “ $W/V$ ” over  $\mathbb{L}(V, W)$ . An *orthogonal spectrum* is a based continuous functor  $F: \mathbb{O} \rightarrow \text{kTop}_*$ , where  $\text{kTop}_*$  is the category of pointed  $k$ -spaces. In other words, it is the assignment to each  $V \in \mathbb{O}$  of a based  $k$ -space  $F(V)$ , and to each pair  $V, W \in \mathbb{O}$  a based map  $F(V) \wedge \mathbb{O}(V, W) \rightarrow F(W)$ , such that this rule is compatible with composition for triples  $V, W, U \in \mathbb{L}$ . The category of orthogonal spectra is denoted by  $\text{OrthSp}$ .

A map of orthogonal spectra  $F \rightarrow F'$  is called a *global equivalence* if and only if for every finite group  $G$ , every orthogonal  $G$ -representation  $V$ , every  $k, \ell \geq 0$  and every diagram of based  $G$ -equivariant maps on the left

$$(6-10) \quad \begin{array}{ccc} \partial D^k \wedge S^V & \longrightarrow & F(V \oplus \mathbb{R}^\ell) \\ \downarrow & & \downarrow \\ D^k \wedge S^V & \longrightarrow & F'(V \oplus \mathbb{R}^\ell) \end{array} \quad \Rightarrow \quad \begin{array}{ccc} \partial D^k \wedge S^W & \longrightarrow & F(W \oplus \mathbb{R}^\ell) \\ \downarrow & \nearrow \text{dashed} & \downarrow \\ D^k \wedge S^W & \longrightarrow & F'(W \oplus \mathbb{R}^\ell) \end{array}$$

there exists an orthogonal  $G$ -representation  $W$  and an inclusion  $V \hookrightarrow W$  such that after pushing forward under it, the square obtained on the right has a lift after homotoping the bottom map rel boundary (everything  $G$ -equivariantly); see [34, Equation (3.1.11) and Definition 4.1.3]. The category of global spectra  $\text{GloSp}$  is the localization of the category of orthogonal spectra  $\text{OrthSp}$  at the global equivalences. (There is a model structure on  $\text{OrthSp}$  whose weak equivalences are the global equivalences, giving an effective way to understand the localization  $\text{GloSp}$ ; see [34, Section 4.3].)

Given an orthogonal spectrum  $F$  and a vector bundle  $V \rightarrow X$  with inner product (over any stack  $X$ ), we may define a representable map  $F(V) \rightarrow X$  by applying  $F$  to the fibers of  $V$ , just as we did for an orthogonal space. This map  $F(V) \rightarrow X$  is moreover equipped with a “basepoint” section. A vector bundle  $V \rightarrow X$  (where  $X$  is still any stack) has an associated sphere bundle  $S^V$  (fiberwise one-point compactification of  $V$ ) again by defining it over  $\bigsqcup_{n \geq 0} */\text{GL}_n(\mathbb{R})$  and pulling back under the classifying map; this is also equipped with a “basepoint” section. We may thus consider, for any vector bundle  $V \rightarrow X$  with inner product, based maps  $S^V \rightarrow F(V)$  over  $X$ , where “based”

means that the composition of the basepoint section of  $S^V$  with the map  $S^V \rightarrow F(V)$  is the basepoint section of  $F(V)$ .

Let us now argue that given an isometric inclusion of vector bundles with inner product  $V \hookrightarrow W$ , we may push forward a based map  $S^V \rightarrow F(V)$  to obtain a based map  $S^W \rightarrow F(W)$ . The structure of  $F$  as an orthogonal spectrum gives a based map  $F(V) \rightarrow F(W)$  over the total space of  $S^{W/V}$ , which over the basepoint section of  $S^{W/V}$  (ie when pulled back under it) is the constant map to the basepoint section of  $F(W)$ . Precomposing this map  $S^{W/V} \times_X F(V) \rightarrow F(W)$  over  $X$  with a map  $S^V \rightarrow F(V)$  over  $X$  defines a map  $S^V \times_X S^{W/V} \rightarrow F(W)$ , which we claim descends uniquely to a map  $S^W \rightarrow F(W)$ . To prove this claim, it suffices to show that the obvious<sup>3</sup> map  $S^V \times_X S^{W/V} \rightarrow S^W$  pulls back under any map  $Z \rightarrow X$ , where  $Z$  is a topological space, to a topological quotient map. Since vector bundles (inner product is now irrelevant) are locally trivial, this amounts to showing that  $S^n \times S^m \times Z \rightarrow S^{n+m} \times Z$  is a topological quotient map for any topological space  $Z$ , which holds since the locus  $(\{*\} \times S^m) \cup (S^n \times \{*\}) \subseteq S^n \times S^m$  contracted by  $S^n \times S^m \rightarrow S^{n+m}$  is compact.

We now show that global spectra give rise to cohomology theories on orbispectra. Namely, we construct a functor

$$(6-11) \quad (\text{OrbSp}^f)^{\text{op}} \times \text{GloSp} \rightarrow \text{Ab},$$

$$(6-12) \quad W \times Z \mapsto Z^0(W),$$

sending cofiber sequences to exact sequences.

We begin by defining  $(W, Z) \mapsto Z^0(W)$  as a functor

$$(\text{OrbSpcPair}^{f, -\text{Vect}})^{\text{op}} \times \text{OrthSp} \rightarrow \text{Ab}.$$

For a finite orbi-CW-pair  $(X, A)$  with vector bundle  $\xi$  and an orthogonal spectrum  $F$ , we consider homotopy classes of based maps  $S^V \rightarrow F(V \oplus \xi)$  over  $X$ , which over a neighborhood of  $A$  are the constant map to the basepoint. By the discussion in the paragraph just above, such homotopy classes of maps form a directed system over  $V \in \text{Vect}^O(X)$ , and we define  $F^0((X, A)^{-\xi})$  to be its direct limit; this set is naturally an abelian group by the usual argument involving  $\mathbb{R}^2 \subseteq E$ . As before, this is only a reasonable definition because of enough vector bundles. Note that, for the purposes of computing the set of homotopy classes of based maps  $S^V \rightarrow F(V \oplus \xi)$ ,

<sup>3</sup>Obvious since its existence over the universal classifying space is clear, so we can just pull back to  $X$ .

we may consider just those which are properly supported over  $X$  in the sense that they send a neighborhood of the fiberwise basepoint of  $S^V$  to the fiberwise basepoint of  $F(V \oplus \xi)$  — to see this, apply a map  $S^V \rightarrow S^V$  which sends a neighborhood of the basepoint to the basepoint, which we may construct universally over  $\bigsqcup_{n \geq 0} */O(n)$ . That  $F^0((X, A)^{-\xi})$  is a functor of  $F \in \text{OrthSp}$  is evident. The following implies descent to a functor of  $F \in \text{GloSp}$ .

**Lemma 6.7** *A global equivalence of orthogonal spectra  $Z \rightarrow Z'$  induces an isomorphism  $Z^0((X, A)^{-\xi}) \rightarrow Z'^0((X, A)^{-\xi})$ .*

**Proof** Same as Lemma 6.1. □

We now argue that  $Z^0((X, A)^{-\xi})$  is functorial in  $(X, A)^{-\xi} \in \text{OrbSpcPair}^{f, -\text{Vect}}$ . Suppose given a map  $f : X \rightarrow Y$ , an inclusion  $f^*\zeta \hookrightarrow \xi$  and a section  $s : X \rightarrow \xi/f^*\zeta$  such that  $A$  is covered by  $f^{-1}(B)$  and the locus where  $|s| \geq \varepsilon$  for some  $\varepsilon > 0$ . Now given a map  $S^V \rightarrow F(V \oplus \zeta)$  over  $Y$  supported away from  $B$ , we may pull it back to obtain a map  $S^{f^*V} \rightarrow F(f^*V \oplus f^*\zeta)$  over  $X$  supported away from  $f^{-1}(B)$ . We then further pair with  $s$ , viewed as a section of  $S^\xi/f^*\zeta$ , to obtain a map  $S^{f^*V} \rightarrow F(f^*V \oplus \xi)$  supported away from  $A$ . To finish the construction of (6-11), it suffices to show that morphisms  $W$  and  $S$  are sent to isomorphisms. That morphisms  $W$  are sent to isomorphisms follows from enough vector bundles (Theorem 3.23) — restriction of vector bundles is cofinal. That morphisms  $S$  are sent to isomorphisms is immediate from the definition.

**Proposition 6.8** *For any global spectrum  $Z$ , the functor  $Z^0$  sends cofiber sequences in  $\text{RepOrbSp}^f$  to exact sequences.*

**Proof** We are to show that  $Z^0(Y, B) \leftarrow Z^0(X, A) \leftarrow Z^0(X, A \cup_B Y)$  is exact. The composition is evidently zero. Now suppose we have a section over  $(X, A)$  whose restriction to  $(Y, B)$  is nullhomotopic after stabilizing by a vector bundle on  $Y$ . The restriction map on vector bundles is cofinal by enough vector bundles, so without loss of generality we are in the situation of a section on  $(X, A)$  whose restriction to  $(Y, B)$  is nullhomotopic rel  $B$ . Now  $(Y, B)$  has a nice neighborhood inside  $(X, A)$ , so we can extend this nullhomotopy to a homotopy of sections over  $(X, A)$  to become supported away from  $A \cup_B Y$ . □

Define  $Z^i(W) := Z^0(\Sigma^{-i}W)$ , so the Puppe sequence now gives a bi-infinite long exact sequence of the expected form for any cofiber triple in  $\text{RepOrbSp}^f$ .

### 6.4 Global Thom spectra

We now recall the so-called *global Thom spectra* [34, Section 6], whose associated cohomology theories are called homotopical cobordism theories. They are given by the orthogonal spectra

$$(6-13) \quad \mathbf{S}(V) := S^V,$$

$$(6-14) \quad \mathbf{mO}(V) := \text{Gr}_{|V|}(V \oplus \mathbb{R}^\infty)^\tau,$$

$$(6-15) \quad \mathbf{MO}(V) := \text{Gr}_{|V|}(V \oplus V)^\tau,$$

where  $\tau$  denotes the tautological vector bundle. The structure maps are induced by those of the corresponding  $\mathbf{bO}$  and  $\mathbf{BO}$  defined above, just passing to Thom spaces as appropriate. In the present context of orthogonal spectra, Thom space always means the one-point compactification of the total space. These are ring spectra in various senses, however we will not discuss this precisely, instead referring to Section 6 of Schwede [34].

There is a canonical “unit element”  $\mathbf{1} \in \mathbf{S}^0(X)$  for any orbispace  $X$ , namely that given in the definition of  $\mathbf{S}^0(X)$  by taking  $E = 0$  and taking the unit section of  $\Omega^E \mathbf{S}(E) = S^0$  over  $X$ .

**Remark 6.9** It is natural to conjecture that  $S^0 \in \text{OrbSpc}_*$  is sent to  $\mathbf{S}$  and that  $\varinjlim_n \mathbf{BO}(n)^{\mathbb{R}^n - \xi_n} \in \text{OrbSp}$  is sent to  $\mathbf{mO}$ , under natural functors to  $\text{GloSp}$ . As we have not defined an orbispace  $\mathbf{BO}$ , we cannot define an orbispectrum corresponding to  $\mathbf{MO}$ .

### 6.5 Pontryagin–Thom isomorphism

Theorem 1.4 is the combination of Propositions 6.10 and 6.11 below.

**Proposition 6.10** *There is a bijection  $\mathbf{S}^0(DW) \xrightarrow{\sim} \Omega_0^{\text{fr}}(W)$ , which is natural in  $W \in \text{RepOrbSp}^f$ .*

For a compact orbifold-with-boundary  $X$ , this bijection sends the unit element  $\mathbf{1} \in \mathbf{S}^0(X)$  to the fundamental class  $[X] \in \Omega_0^{\text{fr}}((X, \partial X)^{-TX})$ .

**Proof** Given a compact orbifold pair  $(X, A)$  and a vector bundle  $\xi$  over  $X$ , we define a map

$$(6-16) \quad \mathbf{S}^0((X, \partial X - A^\circ)^{\xi - TX}) \rightarrow \Omega_0^{\text{fr}}((X, A)^{-\xi})$$

as follows. The value of  $\mathbf{S}^0((X, \partial X - A^\circ)^{\xi - TX})$  is the direct limit over vector bundles  $E/X$  of (homotopy classes of) sections of  $\Omega^{E \oplus \xi} S^{E \oplus TX}$  over  $X$  supported away from  $\partial X - A^\circ$ . Equivalently, this is sections  $s$  of  $S^{E \oplus TX}$  (the fiberwise one-point compactification) over the total space of  $E \oplus \xi$  over  $X$  whose zero set  $s^{-1}(0)$  is proper over  $X$  and disjoint from the inverse image of  $\partial X - A^\circ$ . Such data defines a compact derived orbifold chart with boundary  $(D, E \oplus TX, s)$  (here  $D$  is an open subset of the total space of  $E \oplus \xi$ ), representable over  $(X, A)$ , with a stable isomorphism between its tangent bundle and  $\xi$ ; this defines an element of  $\Omega_0^{\text{fr}}((X, A)^{-\xi})$ . This construction is compatible with enlarging  $E$ , and sends homotopies of sections to bordisms, hence defines the desired map (6-16).

Let us argue that (6-16) defines a natural transformation of functors  $\mathbf{S}^0(DW) \rightarrow \Omega_0^{\text{fr}}(W)$  of  $W \in \text{RepOrbSp}^f$ . By Proposition 3.33 and the universal property of localization (and of direct limit), it suffices to show that this defines a natural transformation of functors out of  $\text{RepOrbSpcPair}_{N,k}^{f, -\xi}$  for every  $\xi \in \text{Vect}(R(*)_{N,k+2})$ , compatible with the functors modifying  $\xi$  and  $N, k$ . Compatibility with the functors modifying  $\xi$  and  $N, k$  is immediate; the real content is to check that the diagram

$$(6-17) \quad \begin{array}{ccc} \mathbf{S}^0(DW) & \longrightarrow & \Omega_0^{\text{fr}}(W) \\ \downarrow & & \downarrow \\ \mathbf{S}^0(DZ) & \longrightarrow & \Omega_0^{\text{fr}}(Z) \end{array}$$

commutes for any map  $W \rightarrow Z$  in  $\text{RepOrbSpcPair}_{N,k}^{f, -\xi}$ . We may assume that this map  $W \rightarrow Z$  is a smooth embedding of compact orbifold pairs  $(X, A) \rightarrow (Y, B)$ , namely  $X \hookrightarrow Y$  is a smooth embedding and  $A = X \cap \partial Y$  meeting transversally (so  $X$  has corners at the boundary of  $A$ ), desuspended by a vector bundle  $\xi$  on  $R(*)_{N,k+2}$ , where the isotropy groups of  $X$  and  $Y$  have order  $\leq N$  and  $X, Y$  have dimension  $\leq k$ . In this case, the map on duals is simply the evident map  $(Y, \partial Y - B^\circ) \dashrightarrow (X, \partial X - A^\circ)^{TY/TX}$  desuspended by  $TY$  and suspended by  $\xi$ . Now commutativity of the above diagram is clear.

It remains to show that the natural transformation  $\mathbf{S}^0(DW) \rightarrow \Omega_0^{\text{fr}}(W)$  is a bijection for every  $W \in \text{RepOrbSp}^f$ , which we may take to be of the form  $(X, A)^{-\xi}$  for a compact orbifold pair  $(X, A)$  with a vector bundle  $\xi$  over  $X$ . To show surjectivity, let  $(D, E, s)$  be a derived orbifold-with-boundary chart with a representable map  $(D, \partial D) \rightarrow (X, A)$  and a stable isomorphism  $TD - E = \xi$ . By Corollary 3.24, the map from  $D$  to  $X$  can be replaced by a smooth embedding by replacing  $X$  with the unit disk bundle of

a vector bundle over  $X$  (and  $A$  is replaced with its inverse image in this total space). Thus we may assume  $D$  is a suborbifold of  $X$ ; choosing a nice collar near  $\partial X$ , we may further assume that it meets  $\partial X$  transversely, precisely along  $\partial D$ . Now we may stabilize our derived orbifold chart by  $TX/TD$  so that  $D$  is in fact an open subset of  $X$ . Now we have a stable isomorphism  $TX - E = \xi$ , namely an isomorphism  $E \oplus \xi \oplus F = TX \oplus F$  for some vector bundle  $F$ . By further replacing  $X$  with the total space of  $F$  and stabilizing our derived orbifold chart by  $F$ , this becomes a true isomorphism of vector bundles  $TX = E \oplus \xi$  over  $D$ , which remains an open subset of  $X$ . Further stabilizing by  $\xi$  (thus adding  $\xi$  to both  $E$  and  $TX$ ) ensures that  $E$  extends to all of  $X$ , together with the isomorphism  $TX = E \oplus \xi$ . Now the section  $s$  cutting out our derived orbifold is, after extension as “infinity” to the rest of  $X$ , a section of  $S^E$ . This gives, by definition, an element of  $\mathbf{S}^0((X, \partial X - A^\circ)^{-E}) = \mathbf{S}^0((X, \partial X - A^\circ)^{\xi - TX})$  which maps to our given element of  $\Omega_0^{\text{fr}}((X, A)^{-\xi})$ .

Finally, injectivity is just a relative version of surjectivity. We are given two elements of  $\mathbf{S}^0((X, \partial X - A^\circ)^{\xi - TX})$  with the same image in  $\Omega_0^{\text{fr}}((X, A)^{-\xi})$ . Applying “rel boundary” the same procedure used to prove surjectivity to the derived bordism relating the images of our two given elements of  $\mathbf{S}^0((X, \partial X - A^\circ)^{\xi - TX})$  produces a homotopy between them. □

**Proposition 6.11** *For  $W \in \text{RepOrbSp}^f$ , there are natural bijections*

$$(6-18) \quad \mathbf{mO}^0(DW) \xrightarrow{\sim} \Omega_0(W),$$

$$(6-19) \quad \mathbf{MO}^0(DW) \xrightarrow{\sim} \Omega_0^{\text{der}}(W).$$

**Proof** We follow the proof of Proposition 6.10.

Given a compact orbifold pair  $(X, A)$  and a vector bundle  $\xi$  over  $X$ , we define maps

$$(6-20) \quad \mathbf{mO}^0((X, \partial X - A^\circ)^{\xi - TX}) \rightarrow \Omega_0((X, A)^{-\xi}) = \Omega_{|\xi|}^{\xi + \text{cst}, \text{der}}(X, A),$$

$$(6-21) \quad \mathbf{MO}^0((X, \partial X - A^\circ)^{\xi - TX}) \rightarrow \Omega_0^{\text{der}}((X, A)^{-\xi}) = \Omega_{|\xi|}^{\text{der}}(X, A),$$

as follows. The values of  $\mathbf{mO}^0((X, \partial X - A^\circ)^{\xi - TX})$  and  $\mathbf{MO}^0((X, \partial X - A^\circ)^{\xi - TX})$  are, respectively, the direct limits over vector bundles  $E/X$  of (homotopy classes of) sections of

$$(6-22) \quad \Omega^{E \oplus \xi} \text{Gr}_{|E|+|TX|}(E \oplus TX \oplus \mathbb{R}^{|E|+|TX|})^\tau,$$

$$(6-23) \quad \Omega^{E \oplus \xi} \text{Gr}_{|E|+|TX|}(E \oplus TX \oplus E \oplus TX)^\tau,$$



over  $X$  supported away from  $\partial X - A^\circ$ . Equivalently, this is open subsets  $U$  of the total space of  $E \oplus \xi$  over  $X$  carrying a rank  $|E| + |TX|$  vector bundle  $V \subseteq E \oplus TX \oplus \mathbb{R}^{|E|+|TX|}$  (resp.  $V \subseteq E \oplus TX \oplus E \oplus TX$ ), and a section  $s: U \rightarrow V$  whose zero set  $s^{-1}(0)$  is proper over  $X$  and disjoint from the inverse image of  $\partial X - A^\circ$ . Such data defines a compact derived orbifold chart with boundary  $(U, V, s)$ , representable over  $(X, A)$ , with a stable isomorphism between its tangent bundle and  $TX + E + \xi - V$  (which in the case of  $\mathbf{mO}$  is identified with  $\xi + (E \oplus TX \oplus \mathbb{R}^{|E|+|TX|}) / V - \mathbb{R}^{|E|+|TX|}$ ). We thus obtain an element of  $\Omega_{|\xi|}^{\xi + \text{cst, der}}(X, A) = \Omega_0^{\text{cst, der}}((X, A)^{-\xi}) = \Omega_0((X, A)^{-\xi})$  (resp.  $\Omega_0^{\text{der}}((X, A)^{-\xi})$ ). This construction is compatible with enlarging  $E$  and sends homotopies of sections to bordisms, hence defines the desired maps (6-20)–(6-21).

The proof that (6-20)–(6-21) define natural transformations of functors (6-18)–(6-19) of  $W \in \text{RepOrbSp}^f$  is exactly as in the proof of Proposition 6.10.

It remains to show that the natural transformations (6-18)–(6-19) are bijections for  $W = (X, A)^{-\xi}$  for a compact orbifold pair  $(X, A)$  with a vector bundle  $\xi$  over  $X$ . As before, the argument for injectivity is a relative version of that for surjectivity, so we will just explain surjectivity. To show surjectivity, let  $(D, V, s)$  be a derived orbifold-with-boundary chart with a representable map  $(D, \partial D) \rightarrow (X, A)$  and, in the case of  $\mathbf{mO}$ , a vector bundle  $B$  and a stable isomorphism  $TD - V = \xi + B - \mathbb{R}^{|B|}$  (in the case of  $\mathbf{MO}$ , with  $\dim TD - |E| = |\xi|$ ). As in the proof of Proposition 6.10, we may homotope and stabilize to reduce to the case that  $D$  is an open subset of  $X$ . Now further stabilize both  $X$  and  $D$  by the vector bundle  $\xi$ , so that we now have an isomorphism  $TX = \xi \oplus E$  where  $E$  is the tangent bundle before stabilizing. We seek an element of  $\mathbf{mO}^0((X, \partial X - A^\circ)^{-E})$  (resp.  $\mathbf{MO}^0$ ); more specifically, we will produce a section of  $\text{Gr}_{|E|}(E \oplus E)^\tau$  (resp.  $\text{Gr}_{|E|}(E \oplus E)^\tau$ ). We have a stable isomorphism  $E \oplus \mathbb{R}^{|B|} = V \oplus B$  (resp. an equality  $|V| = |E|$ ); in the former case we may stabilize  $X$  and  $D$  to get a true isomorphism. For  $\mathbf{mO}^0$ , we want to embed  $V \hookrightarrow E \oplus \mathbb{R}^{|E|}$ , which we get from the isomorphism  $E \oplus \mathbb{R}^{|B|} = V \oplus B$  once  $|E| \geq |B|$  which we can achieve by stabilizing. For  $\mathbf{MO}^0$ , we want  $V \hookrightarrow E \oplus E$ . Stabilizing to  $V'$  and  $E'$  allows us to embed  $V \hookrightarrow E' \oplus E$  hence  $V' \hookrightarrow E' \oplus E'$ . □

## 7 Bordism and stable maps

In this final section, we apply the Pontryagin–Thom principle to describe morphism spaces in  $\text{RepOrbSp}^f$  and  $\text{OrbSp}^f$  in terms of derived orbifold bordism.

**Proof of Theorem 1.7** Fix a compact orbifold pair  $(X, A)$  with a vector bundle  $\xi$  and a finite orbi-CW-pair  $(Y, B)$  with vector bundle  $\zeta$ . Given a map in  $\text{RepOrbSp}^f$  (resp.  $\text{OrbSp}^f$ )

$$(7-1) \quad D((X, A)^{-\xi}) = (X, \partial X - A^\circ)^{\xi - TX} \rightarrow (Y, B)^{-\zeta},$$

we associate as follows a bordism class of derived orbifold chart with boundary  $(C, \partial C)$  with a map  $(C, \partial C) \rightarrow (X, A) \times (Y, B)$  whose projections to  $X$  and  $Y$  (resp. to  $X$ ) are representable, and with a stable isomorphism between its tangent bundle and  $\xi + \zeta$ . The data of a map (7-1) consists of a vector bundle  $E$  over  $X$ , an open subset  $U$  of the total space of  $E \oplus \xi$ , a (representable) map  $h: U \rightarrow Y$ , an embedding  $h^*\zeta \hookrightarrow TX \oplus \xi$  and a section  $s$  of the quotient whose zero set is proper over  $X$  such that  $\partial X - A^\circ$  is contained in the union of  $f^{-1}(B)$  and the locus where  $|s| \geq \varepsilon$  for some  $\varepsilon > 0$ . This data defines for us a compact derived orbifold chart  $(U, (TX \oplus E)/h^*\zeta, s)$ , which has the desired form by inspection. Homotopies of maps evidently induce bordisms.

Let us argue that this association (of a bordism class to a stable map) is natural in  $(Y, B)^{-\zeta}$ . To make sense of this statement, we should note that bordism of derived orbifolds of the requisite form is indeed a functor of  $(Y, B)^{-\zeta} \in \text{RepOrbSpcPair}^{f, -\text{Vect}}$  (resp.  $\text{OrbSpcPair}^{f, -\text{Vect}}$ ), where a map  $(Y, B)^{-\zeta} \rightarrow (Y', B')^{-\zeta'}$  given by  $q: Y \rightarrow Y'$ ,  $q^*\zeta' \hookrightarrow \zeta$  and  $s: Y \rightarrow \zeta/q^*\zeta'$  pushes forward a derived orbifold mapping  $(Y, B)$  under  $q$  and adds  $\zeta/q^*\zeta'$  to the obstruction space and  $s$  to the obstruction section. This evidently descends to  $\text{RepOrbSp}^f$  (resp.  $\text{OrbSp}^f$ ) due to sending to isomorphisms the morphisms  $W$  (obvious) and  $S$  (same as Proposition 5.5). Now to see that the association of a bordism class to a stable map is natural, due to the universal property of localization it suffices to show it is a natural transformation of functors of  $(Y, B)^{-\zeta} \in \text{RepOrbSpcPair}^{f, -\text{Vect}}$  (resp.  $\in \text{OrbSpcPair}^{f, -\text{Vect}}$ ). This is evident by inspection.

Next, to see naturality in  $(X, A)^{-\xi} \in \text{RepOrbSp}^f$ , we may argue as in the proof of Proposition 6.10: it suffices to check naturality as a functor out of  $\text{RepOrbSpcPair}_{N,k}^{f, -\xi}$  for  $\xi \in \text{Vect}(R(*))_{N,k+2}$ , and this can be seen by inspection upon arranging maps to be smooth embeddings of orbifolds.

It remains to show that this association of a bordism class to a map (7-1) is bijective. As in the proof of Proposition 6.10, injectivity is simply a relative version of surjectivity, so we will just prove surjectivity. Thus, suppose given a compact derived orbifold chart with boundary  $(D, V, s)$  with a representable map  $f$  to  $X$ , a (representable) map  $g$  to  $Y$  with  $\partial D \subseteq f^{-1}(A) \cup g^{-1}(B)$ , and a stable isomorphism between its tangent bundle  $TD - V$  and  $f^*\xi + g^*\zeta$ . By replacing  $(X, A)$  with the total space of

a vector bundle over it, we may assume the map  $D \rightarrow X$  is a smooth embedding. By stabilizing  $(D, V, s)$ , we may assume  $D \rightarrow X$  is an open inclusion, so we have a stable isomorphism  $TX = V \oplus \xi \oplus g^*\zeta$  over  $D$ . Now further stabilize by  $\xi$  so that we have an everywhere-defined isomorphism  $TX = \xi \oplus E$  (so  $E$  is the tangent bundle of  $X$  before stabilizing). The resulting stable isomorphism  $E = V \oplus g^*\zeta$  may be turned into a genuine isomorphism by further stabilization. We want a map  $(X, \partial X - A^\circ)^{-E} \rightarrow (Y, B)^{-\zeta}$ , and this is precisely what we have: our open subset of  $X$  is  $D$ , which has a (representable) map  $g: D \rightarrow Y$ , we have an embedding  $g^*\zeta \hookrightarrow g^*\zeta \oplus V = E$ , and we have a section of the quotient  $V$ , namely the obstruction section.  $\square$

**Example 7.1** We describe the set of stable (representable) maps  $\mathbf{B}G \rightarrow \mathbf{B}H$  for finite groups  $G$  and  $H$ . Such maps (ie morphisms in  $\text{RepOrbSp}^f$  and  $\text{OrbSp}^f$ ) are, according to Theorem 1.7, in bijection with bordism classes of derived orbifolds  $C$  with a representable map to  $\mathbf{B}G$ , a (representable) map to  $\mathbf{B}H$  and a stable isomorphism  $TC = 0$ . By Wasserman’s theorem (Theorem 5.7), this is the same as bordism classes of orbifolds  $C$  with the requisite (representable) maps and stable framing. Now  $C$  has dimension zero, so it must be a disjoint union of  $\mathbf{B}K$  for some finite groups  $K$ ; the only bordisms between these have the form  $\mathbf{B}K \times [0, 1]$ , so bordism is just homotopy. A homotopy class of (representable) map  $\mathbf{B}K \rightarrow \mathbf{B}G$  is a  $G$ -conjugacy class of (injective) homomorphism  $K \rightarrow G$ . A stable framing of  $\mathbf{B}K$  is, according to Example 4.6, an element of the product of  $\mathbb{Z}/2$  over all irreducible real representations of  $K$  with  $\text{End}(\rho) = \mathbb{R}$ . We thus obtain a group-theoretic description of the morphism space  $\mathbf{B}G \rightarrow \mathbf{B}H$  in  $\text{RepOrbSp}^f$  and in  $\text{OrbSp}^f$ .

Stated slightly differently, Theorem 1.7 says that the category  $\text{RepOrbSp}^f$  may be described as follows. The objects of  $\text{RepOrbSp}^f$  are denoted by  $(X, A)^{-\xi}$ , where  $(X, A)$  is a compact orbifold pair and  $\xi$  is a stable vector bundle over  $X$ . The morphisms  $(X, A)^{-\xi} \rightarrow (Y, B)^{-\zeta}$  are bordism classes of derived orbifolds  $(C, \partial C) \rightarrow (X, \partial X - A^\circ) \times (Y, B)$  whose projections to  $X$  and to  $Y$  are representable, equipped with a stable isomorphism  $TC = TX - f^*\xi + g^*\zeta$ . Composition is given by derived fiber product. In this description, the action of duality  $D$  is obvious: it trades  $(X, A)^{-\xi}$  for  $(X, \partial X - A^\circ)^{\xi - TX}$  with the evident action on morphisms.

There is a notable omission in Theorem 1.7: we have no idea what category one gets if one allows both maps to  $(X, A)$  and to  $(Y, B)$  to be arbitrary (not required to be representable). The resulting category has an apparent involution  $D$ , but that’s all this author knows.

Using Theorem 1.7, we may associate to any map  $X \rightarrow Y$  in  $\text{RepOrbSp}^f$  a map  $X \wedge DY \rightarrow R(*)$  in  $\text{RepOrbSp}^f$  as follows. Given a derived orbifold of the shape prescribed by Theorem 1.7 to specify a map  $X \rightarrow Y$ , we simply note that the same derived orbifold also defines a map  $X \wedge DY \rightarrow R(*)$  by taking the product of the two maps and appealing to the canonical map to  $R(*)$ .

In particular, there is a canonical pairing  $X \wedge DX \rightarrow R(*)$  induced by the identity map  $X \rightarrow X$  (equivalently  $DX \rightarrow DX$ ). It may be described concretely as follows. Let  $(X, A)$  be a compact orbifold pair carrying a vector bundle  $\xi$ . The diagonal map is a map

$$(7-2) \quad (X, \partial X) \rightarrow (X, A) \times (X, \partial X - A^\circ).$$

Now suspend/desuspend to define a map  $(X, \partial X)^{-TX} \rightarrow (X, A)^{-\xi} \times (X, \partial X - A^\circ)^{\xi - TX}$  and then dualize to obtain

$$(7-3) \quad (X, \partial X - A^\circ)^{\xi - TX} \times (X, A)^{-\xi} \rightarrow X,$$

which we may compose with the map  $X \rightarrow R(*)$ . This defines a map  $DZ \wedge Z \rightarrow R(*)$  for  $Z = (X, A)^{-\xi}$ . Tracing through the definition of the bijection in Theorem 1.7, it is immediate that this is indeed the canonical pairing  $Z \wedge DZ \rightarrow R(*)$  as described above.

## References

- [1] **A Ángel**, *A spectral sequence for orbifold cobordism*, from “Algebraic topology—old and new” (M Golasinski, Y Rudyak, P Salvatore, N Saveliev, N Wahl, editors), Banach Center Publ. 85, Polish Acad. Sci. Inst. Math., Warsaw (2009) 141–154 MR Zbl
- [2] **A Angel**, *When is a differentiable manifold the boundary of an orbifold?*, from “Geometric and topological methods for quantum field theory” (H Ocampo, E Pariguán, S Paycha, editors), Cambridge Univ. Press (2010) 330–343 MR Zbl
- [3] **M F Atiyah**, *Bordism and cobordism*, Proc. Cambridge Philos. Soc. 57 (1961) 200–208 MR Zbl
- [4] **K Behrend**, *Introduction to algebraic stacks*, from “Moduli spaces” (L Brambila-Paz, O García-Prada, P Newstead, R P Thomas, editors), London Math. Soc. Lecture Note Ser. 411, Cambridge Univ. Press (2014) 1–131 MR Zbl
- [5] **K Behrend**, **B Noohi**, *Uniformization of Deligne–Mumford curves*, J. Reine Angew. Math. 599 (2006) 111–153 MR Zbl
- [6] **T Bröcker**, **E C Hook**, *Stable equivariant bordism*, Math. Z. 129 (1972) 269–277 MR Zbl
- [7] **A D Brooke-Taylor**, *Products of CW complexes*, preprint (2017) arXiv 1710.05296

- [8] **T A Chapman**, *Invariance of torsion and the Borsuk conjecture*, Canadian J. Math. 32 (1980) 1333–1341 MR Zbl
- [9] **M C Cheng**, *Poincaré duality in Morava  $K$ -theory for classifying spaces of orbifolds*, preprint (2013) arXiv 1305.2731
- [10] **P E Conner, E E Floyd**, *Differentiable periodic maps*, Ergebnisse der Math. 33, Springer (1964) MR Zbl
- [11] **T tom Dieck**, *Bordism of  $G$ -manifolds and integrality theorems*, Topology 9 (1970) 345–358 MR Zbl
- [12] **T tom Dieck**, *Orbittypen und äquivariante Homologie, II*, Arch. Math. (Basel) 26 (1975) 650–662 MR Zbl
- [13] **K S Druschel**, *Oriented orbifold cobordism*, Pacific J. Math. 164 (1994) 299–319 MR Zbl
- [14] **K S Druschel**, *The cobordism of oriented three dimensional orbifolds*, Pacific J. Math. 193 (2000) 45–55 MR Zbl
- [15] **K Druschel**, *Oriented orbifold vertex groups and cobordism and an associated differential graded algebra*, Algebr. Geom. Topol. 15 (2015) 169–190 MR Zbl
- [16] **S Ferry, A Ranicki**, *A survey of Wall's finiteness obstruction*, from “Surveys on surgery theory, II” (S Cappell, A Ranicki, J Rosenberg, editors), Ann. of Math. Stud. 149, Princeton Univ. Press (2001) 63–79 MR Zbl
- [17] **K Fukaya, K Ono**, *Floer homology and Gromov–Witten invariant over integer of general symplectic manifolds: summary*, from “Taniguchi Conference on Mathematics Nara '98” (M Maruyama, T Sunada, editors), Adv. Stud. Pure Math. 31, Math. Soc. Japan, Tokyo (2001) 75–91 MR Zbl
- [18] **D Gepner, A Henriques**, *Homotopy theory of orbispaces*, preprint (2007) arXiv math/0701916
- [19] **J P C Greenlees, H Sadofsky**, *The Tate spectrum of  $v_n$ -periodic complex oriented theories*, Math. Z. 222 (1996) 391–405 MR Zbl
- [20] **A Haefliger**, *Orbi-espaces*, from “Sur les groupes hyperboliques d'après Mikhael Gromov” (E Ghys, P de la Harpe, editors), Progr. Math. 83, Birkhäuser, Boston, MA (1990) 203–213 MR
- [21] **B Juran**, *Orbifolds, orbispaces and global homotopy theory*, preprint (2020) arXiv 2006.12374
- [22] **R C Kirby, L C Siebenmann**, *On the triangulation of manifolds and the Hauptvermutung*, Bull. Amer. Math. Soc. 75 (1969) 742–749 MR Zbl
- [23] **R C Kirby, L C Siebenmann**, *Foundational essays on topological manifolds, smoothings, and triangulations*, Annals of Mathematics Studies 88, Princeton Univ. Press (1977) MR Zbl

- [24] **A Körschgen**, *A comparison of two models of orbispaces*, Homology Homotopy Appl. 20 (2018) 329–358 MR Zbl
- [25] **D Metzler**, *Topological and smooth stacks*, preprint (2003) arXiv math/0306176
- [26] **J Milnor**, *Construction of universal bundles, I*, Ann. of Math. 63 (1956) 272–284 MR Zbl
- [27] **B Noohi**, *Foundations of topological stacks, I*, preprint (2005) arXiv math/0503247
- [28] **B Noohi**, *Homotopy types of topological stacks*, Adv. Math. 230 (2012) 2014–2047 MR Zbl
- [29] **J Pardon**, *Enough vector bundles on orbispaces*, Compos. Math. 158 (2022) 2046–2081 MR Zbl
- [30] **L S Pontryagin**, *Gladkie mnogoobraziya i ih primeneniya v teorii gomotopiï*, Trudy Mat. Inst. Steklov. 45, Izdat. Akad. Nauk SSSR, Moscow (1955) MR Zbl
- [31] **L S Pontryagin**, *Smooth manifolds and their applications in homotopy theory*, Amer. Math. Soc. Transl. (2) 11, Amer. Math. Soc., Providence, RI (1959) MR Zbl
- [32] **C Rezk**, *Global homotopy theory and cohesion*, preprint (2014) Available at <https://faculty.math.illinois.edu/~rezk/global-cohesion.pdf>
- [33] **S Sarkar**, *Complex cobordism of quasitoric orbifolds*, Topology Appl. 194 (2015) 386–399 MR Zbl
- [34] **S Schwede**, *Global homotopy theory*, New Mathematical Monographs 34, Cambridge Univ. Press (2018) MR Zbl
- [35] **S Schwede**, *Orbispaces, orthogonal spaces, and the universal compact Lie group*, Math. Z. 294 (2020) 71–107 MR Zbl
- [36] **E H Spanier**, **J H C Whitehead**, *Duality in homotopy theory*, Mathematika 2 (1955) 56–80 MR Zbl
- [37] **R Thom**, *Quelques propriétés globales des variétés différentiables*, Comment. Math. Helv. 28 (1954) 17–86 MR Zbl
- [38] **A G Wasserman**, *Equivariant differential topology*, Topology 8 (1969) 127–150 MR Zbl
- [39] **J E West**, *Mapping Hilbert cube manifolds to ANR's: a solution of a conjecture of Borsuk*, Ann. of Math. 106 (1977) 1–18 MR Zbl
- [40] **J H C Whitehead**, *Combinatorial homotopy, I*, Bull. Amer. Math. Soc. 55 (1949) 213–245 MR Zbl

Department of Mathematics, Princeton University  
Princeton, NJ, United States

<https://web.math.princeton.edu/~jpardon/>

Proposed: Stefan Schwede  
Seconded: Jesper Grodal, Martin R Bridson

Received: 30 July 2020  
Revised: 16 August 2021

## Higher genus FJRW invariants of a Fermat cubic

JUN LI

YEFENG SHEN

JIE ZHOU

We reconstruct all-genus Fan–Jarvis–Ruan–Witten invariants of a Fermat cubic Landau–Ginzburg space  $(x_1^3 + x_2^3 + x_3^3 : [\mathbb{C}^3/\mu_3] \rightarrow \mathbb{C})$  from genus-one primary invariants, using tautological relations and axioms of cohomological field theories. The genus-one primary invariants satisfy a Chazy equation by the Belorousski–Pandharipande relation. They are completely determined by a single genus-one invariant, which can be obtained from cosection localization and intersection theory on moduli of three-spin curves.

We solve an all-genus *Landau–Ginzburg/Calabi–Yau correspondence conjecture* for the Fermat cubic Landau–Ginzburg space using Cayley transformation on quasi-modular forms. This transformation relates two nonsemisimple CohFT theories: the Fan–Jarvis–Ruan–Witten theory of the Fermat cubic polynomial and the Gromov–Witten theory of the Fermat cubic curve. As a consequence, Fan–Jarvis–Ruan–Witten invariants at any genus can be computed using Gromov–Witten invariants of the elliptic curve. They also satisfy nice structures, including holomorphic anomaly equations and Virasoro constraints.

14N35

1. Introduction	1846
2. The Belorousski–Pandharipande relation and the Chazy equation	1853
3. A genus-one FJRW invariant	1861
4. LG/CY correspondence for the Fermat cubic	1867
5. Ancestor GW invariants for elliptic curves	1871
6. Higher-genus FJRW invariants for the Fermat cubic	1877
Appendix	1882
References	1886

## 1 Introduction

Let  $(d; \delta)$  be a *weight system* such that  $\delta = (\delta_1, \dots, \delta_N) \in \mathbb{Z}_+^N$  is a primitive  $N$ -tuple with  $w_i := d/\delta_i \in \mathbb{Z}_+$ . We say the system is of *Calabi–Yau (CY) type* if

$$(1-1) \quad d = \delta_1 + \dots + \delta_N, \quad \text{ie } \sum_{i=1}^N \frac{1}{w_i} = 1.$$

The *dimension* of the CY-type weight system  $(d; \delta)$  is defined to be

$$\hat{c} = \sum_{i=1}^N \left(1 - \frac{2\delta_i}{d}\right) = N - 2.$$

Let  $\mu_d$  be the multiplicative group consisting of  $d^{\text{th}}$  roots of unity and

$$J_\delta = (\zeta_d^{\delta_1}, \dots, \zeta_d^{\delta_N}) \in \mu_d \quad \text{for } \zeta_d := \exp\left(\frac{2\pi\sqrt{-1}}{d}\right).$$

We call the data  $([\mathbb{C}^N / \langle J_\delta \rangle], W)$  a Landau–Ginzburg (LG) space, where  $W$  is a nondegenerate quasihomogeneous polynomial on  $\mathbb{C}^N$  satisfying

$$W(\lambda^{\delta_1} x_1, \dots, \lambda^{\delta_N} x_N) = \lambda^d W(x_1, \dots, x_N) \quad \text{for all } \lambda \in \mathbb{C}^*.$$

The polynomial  $W$  is assumed to have only an isolated critical point at the origin and not involve quadratic terms  $x_i x_j$  for  $i \neq j$ . In general, we can consider Landau–Ginzburg spaces  $([\mathbb{C}^N / G], W)$  for a group  $G$  which is a subgroup of the group of diagonal symmetries with  $J_\delta \in G$ ; see Chang, J Li and W-P Li [6] and Fan, Jarvis and Ruan [20]. Two enumerative theories can be associated to such an LG space:

- The first is the Gromov–Witten (GW) theory of the  $G/\langle J_\delta \rangle$ -quotient of the hypersurface defined by the vanishing of  $W$  in the corresponding weighted projective space  $\mathbb{P}^{N-1}(\delta_1, \dots, \delta_N)$ . The quotient space is a CY  $(N-2)$ -orbifold by the CY condition in (1-1).
- The second is the Fan–Jarvis–Ruan–Witten (FJRW) theory of the pair  $(W, G)$  as introduced by Fan, Jarvis and Ruan [19; 20].

Both the GW theory and the FJRW theory associated to a CY-type weight system are cohomological field theories (CohFT, for short) in the sense of Kontsevich and Manin [32].



We shall focus on the theories arising from one-dimensional CY-type weight systems. These systems are classified by

$$(1-2) \quad (d; \delta) = (3; 1, 1, 1), (4; 1, 1, 2), (6; 1, 2, 3).$$

The LG space we consider is  $([\mathbb{C}^3/\langle J_\delta \rangle], W)$ , with  $W$  the Fermat polynomials

$$(1-3) \quad W = x_1^{d/\delta_1} + x_2^{d/\delta_2} + x_3^{d/\delta_3}.$$

On the CY side, the hypersurface  $W = 0$  in the weighted projective space  $\mathbb{P}^2(\delta_1, \delta_2, \delta_3)$  is an elliptic curve, denoted by  $\mathcal{E}_d$  or  $\mathcal{E}$  (when the degree  $d$  is implicit or unimportant in the discussion) for simplicity. We focus on the GW theory of  $\mathcal{E}$ . The GW state space is then defined to be  $\mathcal{H}_\mathcal{E} := H^*(\mathcal{E}, \mathbb{C})$ . Let  $\overline{\mathcal{M}}_{g,n}(\mathcal{E}, \beta)$  be the moduli stack of degree- $\beta$  stable maps from a connected genus- $g$  curve with  $n$  markings to the target  $\mathcal{E}$ . Let  $\text{ev}_k$  for  $k = 1, 2, \dots, n$  be the evaluation morphisms,  $\pi$  be the forgetful morphism, and  $[\overline{\mathcal{M}}_{g,n}(\mathcal{E}, \beta)]^{\text{vir}}$  be the virtual fundamental cycle of  $\overline{\mathcal{M}}_{g,n}(\mathcal{E}, \beta)$ . The ancestor GW invariants are given by

$$\langle \alpha_1 \psi_1^{\ell_1}, \dots, \alpha_n \psi_n^{\ell_n} \rangle_{g,n,\beta}^\mathcal{E} = \int_{[\overline{\mathcal{M}}_{g,n}(\mathcal{E}, \beta)]^{\text{vir}}} \prod_{k=1}^n \text{ev}_k^*(\alpha_k) \pi^* \psi_k^{\ell_k}.$$

The ancestor GW correlation function is the formal  $q$ -series

$$(1-4) \quad \langle\langle \alpha_1 \psi_1^{\ell_1}, \dots, \alpha_n \psi_n^{\ell_n} \rangle\rangle_{g,n}^\mathcal{E}(q) = \sum_{d \geq 0} q^\beta \langle \alpha_1 \psi_1^{\ell_1}, \dots, \alpha_n \psi_n^{\ell_n} \rangle_{g,n,\beta}^\mathcal{E}.$$

By the virtual degree counting of  $[\overline{\mathcal{M}}_{g,n}(\mathcal{E}, \beta)]^{\text{vir}}$ , if the series

$$\langle\langle \alpha_1 \psi_1^{\ell_1}, \dots, \alpha_n \psi_n^{\ell_n} \rangle\rangle_{g,n}^\mathcal{E}(q)$$

in (1-4) is nontrivial, then

$$(1-5) \quad \sum_{k=1}^n \left(\frac{1}{2} \deg \alpha_k + \ell_k\right) = (3 - \dim_{\mathbb{C}} \mathcal{E})(g - 1) + n = 2g - 2 + n.$$

On the LG side, we consider the FJRW theory of the pair  $(W, \langle J_\delta \rangle)$  as originally constructed in [19; 20]. The main ingredients consist of a CohFT

$$(\mathcal{H}_{(W, \langle J_\delta \rangle)}, \langle \cdot, \cdot \rangle, \mathbf{1}, \Lambda^{(W, \langle J_\delta \rangle)})$$

and FJRW invariants (see Section 2.1 for details)

$$\langle \alpha_1 \psi_1^{\ell_1}, \dots, \alpha_n \psi_n^{\ell_n} \rangle_{g,n}^{(W, \langle J_\delta \rangle)},$$

with  $\alpha_i$  elements in the vector space  $\mathcal{H}_{(W, \langle J_\delta \rangle)}$ . The space  $\mathcal{H}_{(W, \langle J_\delta \rangle)}$  contains a canonical degree-2 element, denoted by  $\phi$  below. We assemble the FJRW invariants into an *ancestor FJRW correlation function* (as a formal series in  $s$ )

$$(1-6) \quad \langle\langle \alpha_1 \psi_1^{\ell_1}, \dots, \alpha_n \psi_n^{\ell_n} \rangle\rangle_{g,n}^{(W, \langle J_\delta \rangle)}(s) \\ := \sum_{m=0}^{\infty} \frac{1}{m!} \langle \alpha_1 \psi_1^{\ell_1}, \dots, \alpha_n \psi_n^{\ell_n}, \underbrace{s\phi, \dots, s\phi}_m \rangle_{g,n+m}^{(W, \langle J_\delta \rangle)}.$$

## 1.1 LG/CY correspondence via modularity

One of the motivations for constructing the FJRW invariants [19; 20] is to understand mathematically the so-called *Landau–Ginzburg/Calabi–Yau correspondence* proposed by physicists; see Greene, Vafa and Warner [24; 54], Martinec [39] and Witten [56]. The *Landau–Ginzburg/Calabi–Yau correspondence conjecture* (see Chiodo and Ruan [12; 48] and Fan, Jarvis and Ruan [20]) predicts that for a CY-type weight system the corresponding GW and FJRW theories are related. In the past decade, a lot of effort has been made to formulate and solve this conjecture:

- An LG/CY correspondence between the vector spaces was solved by Chiodo and Ruan [13].
- Genus-zero LG/CY correspondence for various pairs  $(W, G)$  has been studied using Givental’s  $I$ -functions; see Basalaeu and Priddis [1], Chiodo, Iritani and Ruan [10; 11], Clader [14] and Lee, Priddis and Shoemaker [36; 37].
- For the quintic 3-fold, the correspondence has been pushed to genus one; see Guo and Ross [25].
- For higher genera, the only known examples in the literature (see Iritani, Milanov, Ruan and Shen [29; 40; 41], Krawitz and Shen [34] and Shen and Zhou [50]) are all generically semisimple, and therefore the correspondence at higher genus is a consequence of the genus-zero correspondence, based on Givental [23] and Teleman’s [52] classification of semisimple CohFTs.

One of our main results is to solve this conjecture at all genera for the Fermat cubic pair  $(W = x_1^3 + x_2^3 + x_3^3, J_\delta)$ , using the properties of moduli spaces and quasimodular forms. We remark that the GW CohFT and the FJRW CohFT for such a pair are not generically semisimple, and therefore this case is beyond the scope of Givental and Teleman’s results.

**1.1.1 Quasimodular forms and the Chazy equation** Specializing to the cases of one-dimensional CY-type weight systems, it is known (see Bloch and Okounkov [3] and Okounkov and Pandharipande [43]) that the GW correlation functions for an elliptic curve are quasimodular forms; see Kaneko and Zagier [30]. The key of this work is to relate the generating series in (1-4) and (1-6) using transformations on quasimodular forms.

Consider the Eisenstein series

$$(1-7) \quad E_{2k}(\tau) := \frac{1}{2\zeta(2k)} \sum_{\substack{c,d \in \mathbb{Z} \\ (c,d)=1}} \frac{1}{(c\tau + d)^{2k}} \quad \text{for } \tau \in \mathbb{H},$$

where  $\zeta$  is the Riemann zeta function. These are holomorphic functions on the upper half-plane  $\mathbb{H}$ , of which  $E_{2k}$  for  $k \geq 2$  are modular under the group  $\Gamma := \mathrm{SL}(2, \mathbb{Z})/\{\pm 1\}$ , while  $E_2$  is *quasimodular* [30]. To be more precise,  $E_2$  is not modular, but its nonholomorphic modification  $\hat{E}_2(\tau, \bar{\tau})$  is modular, where

$$\hat{E}_2(\tau, \bar{\tau}) := E_2(\tau) - \frac{3}{\pi \mathrm{Im}(\tau)}.$$

The set of quasimodular forms (we regard modular forms as special cases of quasimodular forms) for  $\Gamma$  form a ring [30]:

$$(1-8) \quad \tilde{M}_*(\Gamma) := \mathbb{C}[E_2(\tau), E_4(\tau), E_6(\tau)].$$

The set of almost-holomorphic modular forms as introduced in [30] also gives rise to a ring that is isomorphic to  $\tilde{M}_*(\Gamma)$ :

$$(1-9) \quad \hat{M}_*(\Gamma) := \mathbb{C}[\hat{E}_2(\tau, \bar{\tau}), E_4(\tau), E_6(\tau)].$$

Let  $q = \exp(2\pi\sqrt{-1}\tau)$ . The GW invariants of elliptic curves are (see [43]) Fourier coefficients expanded around the infinity cusp  $\tau = \sqrt{-1}\infty$  of certain quasimodular forms. For example,<sup>1</sup> let  $\omega \in H^2(\mathcal{E})$  be the Poincaré dual of the point class. Then

$$(1-10) \quad -24\langle\langle\omega\rangle\rangle_{1,1}^{\mathcal{E}}(q) = E_2(q) = 1 - 24 \sum_{n=1}^{\infty} n \frac{q^n}{1-q^n}.$$

For any  $f \in \tilde{M}_*(\Gamma)$ , we define

$$f'(\tau) := \frac{1}{2\pi\sqrt{-1}} \frac{df}{d\tau}.$$

<sup>1</sup>We are sometimes sloppy about the argument for a quasimodular form when no confusion should arise. For instance, we shall occasionally write  $E_k(q)$  for  $E_k(\tau)$ .

The Eisenstein series  $E_2, E_4$  and  $E_6$  satisfy the so-called Ramanujan identities

$$(1-11) \quad E'_2 = \frac{1}{12}(E_2^2 - E_4), \quad E'_4 = \frac{1}{3}(E_2E_4 - E_6), \quad E'_6 = \frac{1}{2}(E_2E_6 - E_4^2).$$

Eliminating  $E_4$  and  $E_6$ , we see that  $E_2$  is a solution to the so-called Chazy equation,

$$(1-12) \quad 2f''' - 2ff''' + 3(f')^2 = 0.$$

Our key observation is that the Chazy equation (1-12) appears in both GW and FJRW theory for one-dimensional CY weight systems, thanks to the Belorousski–Pandharipande relation discovered in [2].

**Proposition 1** *Consider the LG space  $([\mathbb{C}^3/\langle J_\delta \rangle], W)$  given by (1-2) and (1-3). Then both the genus-one GW correlation function  $-24\langle\omega\rangle_{1,1}^\mathcal{E}(q)$  and the genus-one FJRW correlation function  $-24\langle\phi\rangle_{1,1}^{(W, \langle J_\delta \rangle)}(s)$  are solutions to the Chazy equation (1-12).*

Here for a function  $f(q)$  in  $q$ , we use the convention  $f'(q) = q\partial_q f$ ; for a function  $f(s)$  in  $s$ ,  $f'(s) = \partial_s f$ .

Further, using more tautological relations discovered by Faber and Pandharipande [17] and Ionel [28], we can show that both the GW and FJRW correlation functions in (1-4) and (1-6) are determined by the genus-one correlation functions in Proposition 1.

**Proposition 2** *Consider the LG space  $([\mathbb{C}^3/\langle J_\delta \rangle], W)$  given by (1-2) and (1-3). Let*

$$f = -24\langle\omega\rangle_{1,1}^\mathcal{E} \quad \text{or} \quad f = -24\langle\phi\rangle_{1,1}^{(W, \langle J_\delta \rangle)}.$$

*Then the GW correlation functions in (1-4) (or the FJRW correlation functions in (1-6)) are determined from  $f$  by tautological relations and are elements in the ring  $\mathbb{C}[f, f', f'']$ .*

**1.1.2 LG/CY correspondence via Cayley transformation** By direct calculation, we can show  $\langle\omega\rangle_{1,1}^\mathcal{E}(q)$  and  $\langle\phi\rangle_{1,1}^{(W, \langle J_\delta \rangle)}(s)$  are expansions of the same quasimodular form  $-\frac{1}{24}E_2(\tau)$  at two different points on the upper half-plane. In particular, the GW functions are Fourier expansions around the cusp  $\tau = \sqrt{-1}\infty$ . This viewpoint allows us to relate the GW functions in (1-4) and the FJRW functions in (1-6) by a variant of the Cayley transformation which we now briefly review, following Shen and Zhou [50].

For any point  $\tau_* \in \mathbb{H}$ , there exists a Cayley transform that maps a point  $\tau$  on the upper half-plane  $\mathbb{H}$  to a point  $s(\tau)$  in the unit disk  $\mathbb{D}$ , namely

$$s(\tau) = (\tau_* - \bar{\tau}_*) \frac{\tau - \tau_*}{\tau - \bar{\tau}_*}.$$

This transform is biholomorphic, and we denote its inverse by  $\tau(s)$ . Following Zagier [57] and [50], there exists a Cayley transformation that maps a weight- $k$  almost-holomorphic modular form

$$\hat{f} \in \widehat{M}_*(\Gamma) = \mathbb{C}[\widehat{E}_2(\tau, \bar{\tau}), E_4(\tau), E_6(\tau)]$$

to

$$(1-13) \quad \left( \frac{\tau(s) - \bar{\tau}_*}{\tau_* - \bar{\tau}_*} \right)^k \hat{f}(\tau(s), \overline{\tau(s)}).$$

The Taylor expansion of the image gives a natural way to expand the almost-holomorphic modular form  $\hat{f}$  near  $\tau = \tau_*$ , where the local complex coordinate is  $s(\tau)$ .

Using the fact that  $\widetilde{M}_*(\Gamma)$  and  $\widehat{M}_*(\Gamma)$  are isomorphic differential rings, a *holomorphic Cayley transformation*  $\mathcal{C}_{\tau_*}^{\text{hol}}$  (see Section 4) can then be defined [50]. This turns out to be the correct transformation to relate the GW correlation functions in (1-4) and the FJRW correlation functions in (1-6), both of which are holomorphic, and it allows us to solve the LG/CY correspondence conjecture for the Fermat cubic pair.

**Theorem 3** Consider the Fermat cubic polynomial  $W = x_1^3 + x_2^3 + x_3^3$  and the LG space  $([\mathbb{C}^3/\mu_3], W)$ . There exists a degree- and grading-preserving vector space isomorphism

$$\Psi: \mathcal{H}_{\mathcal{E}} = H^*(\mathcal{E}) \rightarrow \mathcal{H}_{(W, \mu_3)}$$

and a holomorphic Cayley transformation  $\mathcal{C}_{\tau_*}^{\text{hol}}$  with

$$\tau_* = -\frac{\sqrt{-1}}{\sqrt{3}} \exp\left(\frac{2\pi\sqrt{-1}}{3}\right) \in \mathbb{H},$$

such that

$$\mathcal{C}_{\tau_*}^{\text{hol}}(\langle\langle \alpha_1 \psi_1^{\ell_1}, \dots, \alpha_n \psi_n^{\ell_n} \rangle\rangle_{g,n}^{\mathcal{E}}(q)) = \langle\langle \Psi(\alpha_1) \psi_1^{\ell_1}, \dots, \Psi(\alpha_n) \psi_n^{\ell_n} \rangle\rangle_{g,n}^{(W, \mu_3)}(s).$$

The explicit construction of  $\Psi$  and  $\mathcal{C}_{\tau_*}^{\text{hol}}$  will be given in Section 4.

It is straightforward to generalize Theorem 3 to the rest of the one-dimensional CY-type weight systems in (1-2); the only difference lies in the technical computations on the initial genus-one FJRW invariants. This approach of using modular forms was previously introduced in [50] for elliptic orbifold curves.

It is worthwhile to mention that for one-dimensional CY-type weight systems, our approach of the LG/CY correspondence is compatible with the  $I$ -function approach introduced by Chiodo and Ruan [11] and Milanov and Ruan [40]. In fact, the automorphy factor in the Cayley transformation (1-13) provides equivalent information to the symplectic transformation that appears in [11, Corollary 4.2.4].

## 1.2 Applications: higher-genus FJRW invariants and their structures

The higher-genus FJRW invariants are very difficult to compute in general. In our example, with the identification of the correlation functions with quasimodular forms, various results from the GW side can be transformed into the LG side via the holomorphic Cayley transformation, which respects the differential ring structure of quasimodular forms. In particular, higher-genus FJRW invariants can be computed easily, and nice structures of the FJRW correlation functions can be obtained for free.

Indeed, higher-genus FJRW invariants are determined from the results on descendent GW invariants of elliptic curves, given by Bloch and Okounkov [3], whose generating series admit very concrete and beautiful formulae. The following gives a sample of the computations.

**Corollary 4** *For the ancestor FJRW correlation functions, when  $d = 3$ ,*

$$\langle\langle \phi \psi_1^{2g-2} \rangle\rangle_{g,1}^{(W, \mu_3)} = \sum_{\substack{\ell, m, n \geq 0 \\ \ell + 2m + 3n = g}} \frac{b_{m,n}}{\ell!} \left( -\frac{\mathcal{C}_{\tau_*}^{\text{hol}}(E_2)}{24} \right)^\ell \left( \frac{\mathcal{C}_{\tau_*}^{\text{hol}}(E_4)}{24} \right)^m \left( -\frac{\mathcal{C}_{\tau_*}^{\text{hol}}(E_6)}{108} \right)^n,$$

where  $\mathcal{C}_{\tau_*}^{\text{hol}}(E_{2i})$  for  $i = 1, 2, 3$  are holomorphic Cayley transformations of the Eisenstein series  $E_2, E_4, E_6$  whose expansions can be computed explicitly, while  $\{b_{m,n}\}_{m,n}$  are rational numbers that can be obtained recursively.

The holomorphic anomaly equations (HAEs) discovered by Oberdieck and Pixton [42] and the Virasoro constraints discovered by Okounkov and Pandharipande [44] for the GW theory of elliptic curves also carry over to the corresponding FJRW theory. See Corollaries 23 and 24 for the explicit statements.

**Outline** In Section 2 we review the basic construction of CohFTs and use tautological relations, in particular the Belorousski–Pandharipande relation, to prove Propositions 1 and 2. In Section 3 we calculate a genus-one FJRW invariant for the  $d = 3$  case using cosection localization. In Section 4 we prove Theorem 3 using properties of quasimodular forms. In Section 5 we review some results on GW invariants for the elliptic curve and discuss the ancestor/descendent correspondence. In Section 6 we give some applications of the quasimodularity of the GW and FJRW theory for the  $d = 3$  case, such as the explicit computations of higher-genus FJRW invariants based on the results on the GW invariants of the elliptic curve, the derivation of holomorphic anomaly equations and Virasoro constraints they satisfy.

**Acknowledgements** Shen would like to thank Qizheng Yin, Aaron Pixton, and Felix Janda for inspiring discussions on tautological relations. Zhou thanks Baosen Wu and Zijun Zhou for useful discussions.

Li is partially supported by the National Natural Science Foundation of China (no. 12071079). Shen is partially supported by Simons Collaboration grant 587119. Zhou is supported by a start-up grant at Tsinghua University, the young overseas high-level talents introduction plan of China, and the national key research and development program of China (no. 2020YFA0713000). Part of Zhou's work was done while he was a postdoc at the Mathematical Institute of the University of Cologne and was partially supported by German Research Foundation grant CRC/TRR 191.

## 2 The Belorousski–Pandharipande relation and the Chazy equation

We study the two cohomological field theories (GW and FJRW) for the one-dimensional CY-type weight systems using tautological relations and axioms of CohFTs. The key is the identification between the Belorousski–Pandharipande relation and the Chazy equation.

### 2.1 Cohomological field theories

Both the GW theory and the FJRW theory of the LG space  $([\mathbb{C}^N/G], W)$  satisfy axioms of cohomological field theories (CohFT) in the sense of [32], which we briefly recall.

Let  $\overline{\mathcal{M}}_{g,n}$  be the Deligne–Mumford moduli stack of genus- $g$  stable (ie  $2g - 2 + n > 0$ ) curves with  $n$  markings. A *cohomological field theory with a flat identity* is a quadruple

$$(\mathcal{H}, \eta, \mathbf{1}, \Lambda),$$

where the *state space*

$$\mathcal{H} := \mathcal{H}^{\text{even}} \oplus \mathcal{H}^{\text{odd}}$$

is a  $\mathbb{Z}_2$ -graded finite-dimensional  $\mathbb{C}$ -vector space (called a superspace in [32]),  $\eta$  is a nondegenerate pairing on  $\mathcal{H}$ ,  $\mathbf{1} \in \mathcal{H}$  is the *flat identity*, and

$$\Lambda := \{\Lambda_{g,n} \in \text{Hom}(\mathcal{H}^{\otimes n}, H^*(\overline{\mathcal{M}}_{g,n}, \mathbb{C}))\}$$

is a set of multilinear maps satisfying the CohFT axioms below:

(i) Let  $|\cdot|$  be the grading. The maps  $\Lambda_{g,n}$  satisfy

$$(2-1) \quad \Lambda_{g,n}(\dots, \alpha_1, \alpha_2, \dots) = (-1)^{|\alpha_1||\alpha_2|} \Lambda_{g,n}(\dots, \alpha_2, \alpha_1, \dots).$$

(ii) The maps in  $\Lambda$  are compatible with the gluing and the forgetful morphisms

- $\overline{\mathcal{M}}_{g_1, n_1+1} \times \overline{\mathcal{M}}_{g_2, n_2+1} \rightarrow \overline{\mathcal{M}}_{g,n}$  and  $\overline{\mathcal{M}}_{g-1, n+2} \rightarrow \overline{\mathcal{M}}_{g,n}$ ,
- $\pi: \overline{\mathcal{M}}_{g, n+1} \rightarrow \overline{\mathcal{M}}_{g,n}$  forgetting one of the markings.

For example, the compatibility with the forgetful morphism is

$$(2-2) \quad \Lambda_{g, n+1}(\alpha_1, \dots, \alpha_n, \mathbf{1}) = \pi^* \Lambda_{g,n}(\alpha_1, \dots, \alpha_n).$$

(iii) The pairing  $\eta$  is compatible with  $\Lambda_{0,3}$ :

$$\int_{\overline{\mathcal{M}}_{0,3}} \Lambda_{0,3}(\alpha_1, \alpha_2, \mathbf{1}) = \eta(\alpha_1, \alpha_2).$$

Let  $\psi_k \in H^2(\overline{\mathcal{M}}_{g,n})$  be the cotangent line class at the  $k^{\text{th}}$  marking. For each CohFT  $(\mathcal{H}, \eta, \mathbf{1}, \Lambda)$ , one defines the quantum invariants from  $\Lambda$  by

$$(2-3) \quad \langle \alpha_1 \psi_1^{\ell_1}, \dots, \alpha_n \psi_n^{\ell_n} \rangle_{g,n}^\Lambda := \int_{\overline{\mathcal{M}}_{g,n}} \Lambda_{g,n}(\alpha_1, \dots, \alpha_n) \prod_{k=1}^n \psi_k^{\ell_k} \quad \text{for } \alpha_k \in \mathcal{H}.$$

Such invariants are called the ancestor GW invariants for the GW CohFT, and FJRW invariants for the LG CohFT. Our focus is the relation between these two types of invariants arising from the same CY-type LG space  $([\mathbb{C}^N / G], W)$ .

Fix a basis  $\mathcal{B}$  for  $\mathcal{H}$ . It is convenient to choose the elements  $\alpha_k$  from  $\mathcal{B}$  and parametrize  $\alpha_k$  by  $s_k$ . We introduce the *genus-zero primary potential of the CohFT* as a formal power series

$$(2-4) \quad \mathcal{F}_0^\Lambda := \sum_{n \geq 0} \sum_{\alpha_k \in \mathcal{B}} \frac{1}{n!} \langle \alpha_1, \dots, \alpha_n \rangle_{0,n}^\Lambda \prod_{k=1}^n s_k.$$

Here primary means all  $\ell_k = 0$  in (2-3).

**2.1.1 FJRW invariants** The CohFTs arising from GW theories have become a familiar topic since [32]. Here we only recall some basics on the LG CohFT constructed from the FJRW invariants defined in [19; 20]. See also [4; 6; 31; 46] for various CohFT constructions for LG models.



As  $G$  acts on  $\mathbb{C}^N$ , for any  $\gamma \in G$ , the fixed-point set  $\text{Fix}(\gamma)$  is an  $N_\gamma$ -dimensional subspace of  $\mathbb{C}^N$ . Let  $W_\gamma$  be the restriction of  $W$  on  $\text{Fix}(\gamma)$ . Following [20], one considers the graded vector space (called the FJRW state space)

$$(2-5) \quad \mathcal{H}_{(W,G)} = \bigoplus_{\gamma \in G} \mathcal{H}_\gamma,$$

where each  $\mathcal{H}_\gamma$  is the space of  $G$ -invariants of the middle-dimensional relative cohomology in  $\text{Fix}(\gamma)$ . There is a natural pairing  $\langle \cdot, \cdot \rangle$  and an isomorphism (see [20, Section 5.1])

$$(2-6) \quad (\mathcal{H}_{(W,G)}, \langle \cdot, \cdot \rangle) \cong \left( \bigoplus_{\gamma \in G} (\text{Jac}(W_\gamma) \Omega_{\text{Fix}(\gamma)})^G, \text{Res} \right).$$

Here  $\text{Jac}(W_\gamma)$  is the *Jacobi algebra* of  $W_\gamma$ ,  $\Omega_{\text{Fix}(\gamma)}$  is the standard holomorphic volume form on  $\text{Fix}(\gamma)$ , and  $\text{Res}$  is the residue pairing.

In [19; 20], Fan, Jarvis and Ruan constructed the virtual fundamental cycle over the moduli space of  $W$ -spin structures, and a corresponding CohFT

$$(\mathcal{H}_{(W,G)}, \langle \cdot, \cdot \rangle, \mathbf{1}, \Lambda^{(W,G)}),$$

which defines the so-called *FJRW invariants*  $\langle \alpha_1 \psi_1^{\ell_1}, \dots, \alpha_n \psi_n^{\ell_n} \rangle_{g,n}^{(W,G)}$  through (2-3).

We now specialize to a pair  $(W, G)$  given in (1-3) with  $G = \langle J_\delta \rangle$ . For a set of homogeneous elements  $\alpha_k \in \mathcal{H}_{\gamma_k}$  for  $k = 1, 2, \dots, n$ , the dimension formula in [20, Theorem 4.1.8] shows that, if  $\langle \alpha_1 \psi_1^{\ell_1}, \dots, \alpha_n \psi_n^{\ell_n} \rangle_{g,n}^{(W, \langle J_\delta \rangle)}$  is nontrivial, then

$$(2-7) \quad 2g - 2 + n = \sum_{k=1}^n \frac{1}{2} \deg \alpha_k + \sum_{k=1}^n \ell_k.$$

We remark that both  $\mathcal{H}_{J_\delta}$  and  $\mathcal{H}_{J_\delta^{-1}}$  are one-dimensional:  $\mathcal{H}_{J_\delta}$  is spanned by the flat identity  $\mathbf{1} \in \mathcal{H}_{J_\delta}$  and  $\mathcal{H}_{J_\delta^{-1}}$  by a canonical degree-2 element  $\phi \in \mathcal{H}_{J_\delta^{-1}}$ . We let  $s$  be the corresponding linear coordinate of the space  $\mathcal{H}_{J_\delta^{-1}}$ . The constraint (2-7) allows us to define the *ancestor FJRW correlation function* (as a formal series in  $s$ )

$$(2-8) \quad \langle \langle \alpha_1 \psi_1^{\ell_1}, \dots, \alpha_n \psi_n^{\ell_n} \rangle_{g,n}^{(W, \langle J_\delta \rangle)}(s) := \sum_{m=0}^{\infty} \frac{1}{m!} \langle \alpha_1 \psi_1^{\ell_1}, \dots, \alpha_n \psi_n^{\ell_n}, \underbrace{s\phi, \dots, s\phi}_m \rangle_{g,n+m}^{(W, \langle J_\delta \rangle)}.$$

In the following, we will use the subscript  $d$  to label the CY-type weight systems in (1-2). Let  $\Omega = dx_1 \wedge dx_2 \wedge dx_3$ . For each polynomial  $W_d$ , when  $d = 3$  (resp. 4, 6), we consider the element

$$(2-9) \quad h(W_d) = \frac{1}{27} x_1 x_2 x_3 \quad (\text{resp. } \frac{1}{32} x_1^2 x_2^2, \frac{1}{36} x_1^4 x_2).$$

According to (2-6), the FJRW state space is

$$(2-10) \quad \mathcal{H}_{(W_d, G_d)} = \mathcal{H}_{J_\delta} \oplus \mathcal{H}_{J_\delta^{-1}} \oplus \mathcal{H}_{1 \in G_d} = \mathbb{C}\{\mathbf{1}, \phi, \mathbf{b}_1, \mathbf{b}_2\}.$$

Here the even part is spanned by  $\mathbf{1} \in \mathcal{H}_{J_\delta}$  and  $\phi \in \mathcal{H}_{J_\delta^{-1}}$ , while the odd part is spanned by

$$\mathbf{b}_1 = h(W_d)\Omega \quad \text{and} \quad \mathbf{b}_2 = \Omega \in (\text{Jac}(W_d)\Omega)^G \subseteq \mathcal{H}_{1 \in G_d}.$$

The degrees are

$$(2-11) \quad \deg \mathbf{1} = 0, \quad \deg \mathbf{b}_1 = \deg \mathbf{b}_2 = 1, \quad \deg \phi = 2.$$

**2.1.2 Genus-zero comparison** We begin with a comparison between the genus-zero parts of the two theories. On the GW side, recall the state space for the elliptic curve  $\mathcal{E}_d$  is  $H^*(\mathcal{E}_d, \mathbb{C})$ . Let  $\mathbf{1} \in H^0$  be the identity of the cup product, and  $\omega \in H^2$  be the Poincaré dual of the point class. We choose a symplectic basis  $\{e_1, e_2\}$  of  $H^1$  such that

$$e_1 \cup e_2 = -e_2 \cup e_1 = \omega.$$

We define a linear map  $\Psi: H^*(\mathcal{E}_d) \rightarrow \mathcal{H}_{(W_d, (J_\delta))}$  by

$$(2-12) \quad \Psi(\mathbf{1}) = \mathbf{1}, \quad \Psi(\omega) = \phi, \quad \Psi(e_i) = \mathbf{b}_i \quad \text{for } i = 1, 2.$$

Let  $(t_0, t_1, t_2, t)$  be the coordinates with respect to the basis  $\{\mathbf{1}, e_1, e_2, \omega\}$ . Similarly we let  $(u_0, u_1, u_2, u)$  be the coordinates with respect to the basis  $\{\mathbf{1}, \mathbf{b}_1, \mathbf{b}_2, \phi\}$ .

The moduli stack  $\overline{\mathcal{M}}_{g,n}(\mathcal{E}_d, \beta)$  is empty when  $g = 0$  and  $\beta > 0$ . Then according to (2-4), the *genus-zero primary GW potential* is

$$\mathcal{F}_0^{\mathcal{E}_d} = \frac{1}{2}t_0^2t + t_0t_1t_2.$$

A calculation on residue shows that

$$(2-13) \quad \langle \mathbf{1}, \mathbf{1}, \phi \rangle_{0,3}^{W_d} = \langle \mathbf{1}, \mathbf{b}_1, \mathbf{b}_2 \rangle_{0,3}^{W_d} = 1 \quad \text{and} \quad \langle \mathbf{1}, \mathbf{b}_2, \mathbf{b}_1 \rangle_{0,3}^{W_d} = -1.$$

Thus the *genus-zero primary FJRW potential* is

$$\mathcal{F}_0^{W_d} = \frac{1}{2}u_0^2u + u_0u_1u_2 + \text{quantum corrections}.$$

These quantum corrections vanish as shown below. This was first observed by Francis [21, Section 4.2] using WDVV equations.

**Proposition 5** *The map  $\Psi$  in (2-12) is a degree- and grading-preserving ring isomorphism, and*

$$(2-14) \quad \mathcal{F}_0^{W_d} = \frac{1}{2}u_0^2u + u_0u_1u_2.$$

**Proof** It is easy to see that  $\Psi$  preserves the degree and grading. To show  $\Psi$  is a ring isomorphism, it is enough to prove (2-14). The compatibility condition (2-2) implies the string equation in FJRW theory. Combining the degree constraints (2-11) and (2-7), we find that the quantum corrections are encoded in  $C_i(s)$ , where  $C_i(s)$  is the correlation function with  $i$  copies of  $\mathfrak{b}_1$ -insertions and  $4 - i$  copies of  $\mathfrak{b}_2$ -insertions. For example,

$$C_0(s) = \langle\langle \mathfrak{b}_1, \mathfrak{b}_1, \mathfrak{b}_1, \mathfrak{b}_1 \rangle\rangle_{0,4}^{W_d} \quad \text{and} \quad C_3(s) = \langle\langle \mathfrak{b}_1, \mathfrak{b}_2, \mathfrak{b}_2, \mathfrak{b}_2 \rangle\rangle_{0,4}^{W_d}.$$

The  $\mathbb{Z}_2$ -grading (2-1) shows  $C_i(s) = 0$ , because for  $\alpha = \mathfrak{b}_1$  or  $\mathfrak{b}_2$ ,

$$\langle\langle \alpha, \alpha, \dots \rangle\rangle_{g,n}^{W_d} = (-1)^{|\alpha||\alpha|} \langle\langle \alpha, \alpha, \dots \rangle\rangle_{g,n}^{W_d} = -\langle\langle \alpha, \alpha, \dots \rangle\rangle_{g,n}^{W_d}. \quad \square$$

## 2.2 The Belorousski–Pandharipande relation and $g$ -reduction

The tautological rings  $RH(\overline{\mathcal{M}}_{g,n})$  of  $\overline{\mathcal{M}}_{g,n}$  are defined (see [17] for example) as the smallest system of subrings of  $H^*(\overline{\mathcal{M}}_{g,n})$  stable under pushforward and pullback by the gluing and forgetful morphisms. Thus pulling back the tautological relations in  $RH(\overline{\mathcal{M}}_{g,n})$  via the CohFT maps  $\Lambda_{g,n}$  gives relations among quantum invariants. We use this technique to prove Propositions 1 and 2.

### 2.2.1 The Belorousski–Pandharipande relation for a genus-one correlation function

The degree constraints (2-11) and (2-7) show that the nonvanishing genus-one primary FJRW invariants could only come from the coefficients in  $\langle\langle \phi \rangle\rangle_{1,1}^{W_d}(s)$ . We determine this series and the GW correlation function  $\langle\langle \omega \rangle\rangle_{1,1}^{\mathcal{E}^d}(q)$ , up to some initial values, by using the tautological relation found by Belorousski and Pandharipande [2, Theorem 1]. The relation is a nontrivial rational equivalence among codimension-2 descendent stratum classes in  $\overline{\mathcal{M}}_{2,3}$ , shown in Figure 1.

Each stratum in the relation is represented by the topological type of the stable curve corresponding to the generic moduli point in the stratum. The markings on the stratum are unassigned. The geometric genera of the components are underlined. The cotangent line class  $\psi$  always appears on the genus-two component.

**Proof of Proposition 1** On the FJRW side, we integrate

$$\Lambda_{2,3}^{W_d}(\phi, \phi, \phi) \in H^4(\overline{\mathcal{M}}_{2,3})$$

over the Belorousski–Pandharipande relation. We read off one term from each stratum.

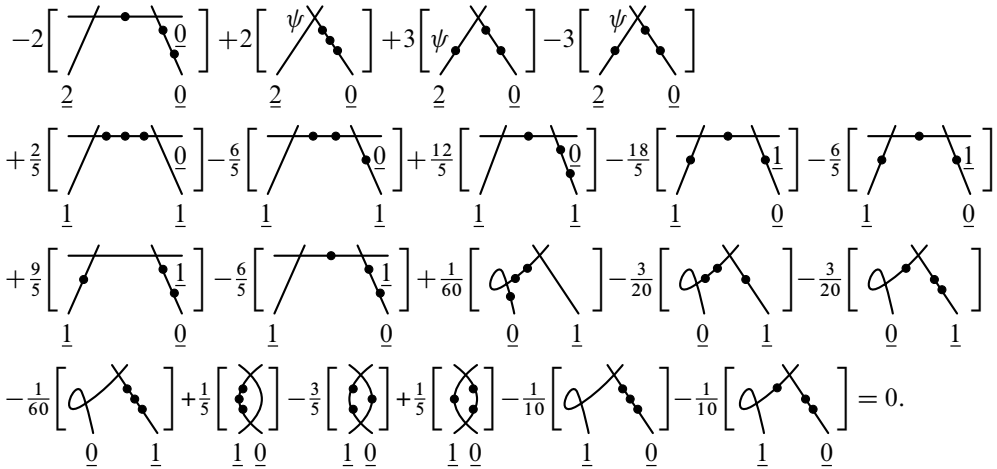

Figure 1: The Belorousski–Pandharipande relation.

**Strata in the first row of Figure 1** Let us consider the first stratum in the first row. Integration over this stratum gives the term

$$-2 \sum_{\alpha, \alpha', \beta, \beta' \in \mathcal{H}_{W_d}} \langle\langle \alpha \rangle\rangle_{2,1}^{W_d}(s) \eta^{\alpha, \alpha'} \langle\langle \alpha', \phi, \beta \rangle\rangle_{0,3}^{W_d}(s) \eta^{\beta, \beta'} \langle\langle \beta', \phi, \phi \rangle\rangle_{0,3}^{W_d}(s).$$

Here the notation  $\eta^{\alpha, \alpha'}$  stands for the  $(\alpha, \alpha')$  component of the inverse of the pairing  $\eta$ , etc. For any homogeneous element  $\alpha \in \mathcal{H}_{W_d}$ , the degree constraint (2-7) implies that if  $\langle\langle \alpha \rangle\rangle_{2,1}^{W_d}(s)$  is nonzero, then

$$2(2 - 1) + 1 = \frac{1}{2} \deg \alpha.$$

This contradicts (2-11), where we have  $\deg \alpha = 0, 1, 2$ . Thus  $\langle\langle \alpha \rangle\rangle_{2,1}^{W_d}(s) = 0$ , and hence the contribution from this stratum is zero. Similar arguments imply that the contribution from all the strata in the first row of Figure 1 vanish, since the contribution from each stratum must contain one of the following terms as a factor:

$$\langle\langle \alpha \rangle\rangle_{2,1}^{W_d}(s) = \langle\langle \alpha \psi_1 \rangle\rangle_{2,1}^{W_d}(s) = \langle\langle \phi \psi_1, \alpha \rangle\rangle_{2,2}^{W_d}(s) = \langle\langle \phi, \alpha \psi_2 \rangle\rangle_{2,2}^{W_d}(s) = 0.$$

**Other vanishing strata** Now we look at the first, second and fifth strata in the second row, the third, fourth and fifth strata in the third row, and the second, third, fifth and sixth strata in the last row. Each stratum has a genus-zero component with at least four markings (including the nodes). According to Proposition 5, for the primary invariants,

$$\langle\langle \dots \rangle\rangle_{0,n}^{W_d} = 0 \quad \text{for all } n \geq 4.$$

Thus the integral of  $\Lambda_{2,3}^{W_d}(\phi, \phi, \phi) \in H^4(\overline{\mathcal{M}}_{2,3})$  over each of these strata vanishes.

For the first and second strata in the third row, the genus-zero component only contains three markings, but at least two of the markings are labeled with the class  $\phi$ . Again by Proposition 5, we have

$$\langle\langle \phi, \phi, \alpha \rangle\rangle_{0,3}^{W_d} = 0 \quad \text{for all } \alpha \in \mathcal{H}_{W_d}.$$

So the contribution from these two strata also vanishes.

Finally, the integral on the first stratum in the fourth row also vanishes. This is a consequence of the  $\mathbb{Z}_2$ -grading. In fact, we apply the degree constraint (2-7) to the genus-one component and find that the nonvanishing contribution from this stratum, if it exists, should be of the form

$$-\frac{1}{60} \sum_{\alpha, \alpha'} \langle\langle \phi, \phi, \phi, \phi \rangle\rangle_{1,4}^{W_d}(s) \eta^{\phi, \mathbf{1}} \langle\langle \mathbf{1}, \alpha, \alpha' \rangle\rangle_{0,3}^{W_d} \eta^{\alpha', \alpha}.$$

The vanishing of this term is a direct consequence of the formula (2-13), where

$$\eta^{\phi, \mathbf{1}} = \eta^{b_1, b_2} = 1 \quad \text{and} \quad \eta^{b_2, b_1} = -1.$$

**Nonvanishing terms** Now we see that all the possibly nonvanishing terms are from the third and fourth strata in the second row, and the fourth stratum in the last row. Let us calculate them term by term. The third stratum of the second row gives a possibly nonvanishing term

$$\frac{12}{5} \langle\langle \phi \rangle\rangle_{1,1}^{W_d}(s) \eta^{\phi, \mathbf{1}} \langle\langle \mathbf{1}, \phi, \mathbf{1} \rangle\rangle_{0,3}^{W_d}(s) \eta^{\mathbf{1}, \phi} \langle\langle \phi, \phi, \phi \rangle\rangle_{1,3}^{W_d}(s) = \frac{12}{5} g g''.$$

The fourth stratum of the second row gives a possibly nonvanishing term

$$-\frac{18}{5} \langle\langle \phi, \phi \rangle\rangle_{1,2}^{W_d}(s) \eta^{\phi, \mathbf{1}} \langle\langle \mathbf{1}, \phi, \mathbf{1} \rangle\rangle_{0,3}^{W_d}(s) \eta^{\mathbf{1}, \phi} \langle\langle \phi, \phi \rangle\rangle_{1,2}^{W_d}(s) = -\frac{18}{5} g' g'.$$

The fourth stratum of the last row gives a possibly nonvanishing term

$$\frac{1}{5} \cdot \frac{1}{2} \langle\langle \mathbf{1}, \phi, \mathbf{1} \rangle\rangle_{0,3}^{W_d}(s) \eta^{\mathbf{1}, \phi} \langle\langle \phi, \phi, \phi, \phi \rangle\rangle_{1,4}^{W_d}(s) \eta^{\phi, \mathbf{1}} = \frac{1}{5} \cdot \frac{1}{2} g'''.$$

Here the denominator 2 in the term above comes from the automorphism of the graph.

Putting all these together, the Belorousski–Pandharipande relation in Figure 1 allows us to verify by brute-force computation that the correlation function  $g := \langle\langle \phi \rangle\rangle_{1,1}^{W_d}(s)$  is a solution to

$$(2-15) \quad \frac{12}{5} g g'' - \frac{18}{5} g' g' + \frac{1}{5} \cdot \frac{1}{2} g''' = 0.$$

Thus  $-24 \langle\langle \phi \rangle\rangle_{1,1}^{W_d}(s)$  is a solution of the Chazy equation (1-12).

By integrating the GW cycle  $\Lambda_{2,3}^{\mathcal{E}_d}(\omega, \omega, \omega)$  over the Belorousski–Pandharipande relation in Figure 1, we similarly see that  $-24\langle\langle\phi\rangle\rangle_{1,1}^{\mathcal{E}_d}(q)$  is a solution of the Chazy equation (1-12). □

The identity (2-15) is independent of the specific form  $\mathcal{E}_d$ , as should be the case since the GW invariants are independent of the choice of complex structures put on the elliptic curve.

**Remark 6** For the elliptic orbifold curve  $\mathcal{X}_N := \mathcal{E}^{(N)}/\mu_N$  for some particular elliptic curve  $\mathcal{E}^{(N)}$  that admits  $\mu_N$  as its automorphism group, the first stratum in the fourth line does not vanish. Let  $\mu$  be the rank of the Chen–Ruan cohomology  $H_{CR}^*(\mathcal{X}_N)$ , which satisfies

$$1 - \frac{\mu}{12} = \frac{1}{N}.$$

Similarly, define  $g = \langle\langle\mathcal{P}\rangle\rangle_{1,1}^{\mathcal{X}_N}$ , where  $\mathcal{P}$  is the point class on  $\mathcal{X}_N$ . The Belorousski–Pandharipande relation now gives

$$\frac{12}{5}gg'' - \frac{18}{5}(g')^2 + (-\frac{1}{60}\mu + \frac{1}{5}) \cdot \frac{1}{2}g''' = 0,$$

where  $' = Q\partial_Q$  is now the derivative with respect to the parameter for the point class  $\mathcal{P}$ . Then  $f = -24g$  satisfies

$$2ff'' - 3(f')^2 - 2(1 - \frac{1}{12}\mu)f''' = 0.$$

Its solutions coincide with those of (2-15) via the relation  $Q = q^N$ ; see [49] for more details.

**2.2.2 g–reduction for higher-genus correlation functions** We prove Proposition 2 using the *g–reduction technique* introduced in [18], first recalling:

**Lemma 7** [17; 28] *Let  $M(\psi, \kappa)$  be a monomial of  $\psi$ –classes and  $\kappa$ –classes  $\overline{\mathcal{M}}_{g,n}$ . Assume  $\deg M \geq g$  when  $g \geq 1$ , and  $\deg M \geq 1$  when  $g = 0$ . Then  $M(\psi, \kappa)$  is equal to a linear combination of dual graphs on the boundary of  $\overline{\mathcal{M}}_{g,n}$ .*

**Proof of Proposition 2** Consider the GW or FJRW correlation function of the form

$$\langle\langle\alpha_1\psi_1^{\ell_1}, \dots, \alpha_n\psi_n^{\ell_n}\rangle\rangle_{g,n}^{\clubsuit}, \quad \text{where } \clubsuit = \mathcal{E}_d \text{ or } W_d.$$

Using that the cohomology classes have  $0 \leq \deg \alpha_k \leq 2$ , and using (1-5) and (2-7), we deduce that the correlation function is trivial if

$$\sum_{k=1}^n \ell_k < 2g - 2.$$

Assuming it is nontrivial and  $\sum_{k=1}^n \ell_k \geq 1$ , we must have

$$(2-16) \quad \deg \left( \prod_{k=1}^n \psi_k^{\ell_k} \right) = \sum_{k=1}^n \ell_k \geq \begin{cases} 2g - 2 \geq g & \text{if } g \geq 2, \\ 1 & \text{if } g = 0, 1. \end{cases}$$

Then,  $\prod_{k=1}^n \psi_k^{\ell_k}$  is a monomial satisfying the condition in Lemma 7, thus we can apply this technique and use the splitting axiom in GW/FJRW theory to rewrite the function as a linear combination of products of other correlation functions, with smaller genera.

We then repeat the process for nontrivial correlation functions with smaller genera and eventually rewrite the correlation function as a linear combination of products of primary (all  $\ell_k = 0$ ) correlation functions in genus zero (which are just constants) and in genus one, which must be  $f_d^{(n-1)} = \langle \omega, \dots, \omega \rangle_{1,n}^{\mathcal{E}_d}$  or  $\langle \phi, \dots, \phi \rangle_{1,n}^{W_d}$ . Thus we have

$$\langle \alpha_1 \psi_1^{\ell_1}, \dots, \alpha_k \psi_n^{\ell_n} \rangle_{g,n}^{\clubsuit} \in \mathbb{C}[f_d, f'_d, f''_d, \dots] = \mathbb{C}[f_d, f'_d, f''_d].$$

The last equality follows from (2-15). □

### 3 A genus-one FJRW invariant

Throughout this section, we consider the  $d = 3$  case, with  $W_3 = x_1^3 + x_2^3 + x_3^3$  and  $G = \mu_3$ . We focus on the following genus-one FJRW invariant (see (1-6)) with  $n = 3$ :

$$\Theta_{1,n} := \underbrace{\langle \phi, \dots, \phi \rangle_{1,n}}_n^{(W_3, \mu_3)}.$$

Combining the computations in [38], we will prove:

**Proposition 8** [38, Theorem 1.1] *For the  $(W_3, \mu_3)$  case, one has the FJRW invariant*

$$(3-1) \quad \Theta_{1,3} = \langle \phi, \phi, \phi \rangle_{1,3}^{(W_3, \mu_3)} = \frac{1}{108}.$$

We first obtain a formula that expresses the Witten top Chern class for  $\Theta_{1,3}$  in terms of a Witten top Chern class of three-spin curves in Lemma 9. Then in Proposition 15 and Corollary 17, we analyze the latter virtual class explicitly by cosection localization. Finally, we deduce Proposition 8 from these results and explicit computations in [38].

#### 3.1 Witten top Chern class

We begin with a formula for a Witten top Chern class of the moduli of three-spin curves. The relevant moduli  $\overline{\mathcal{M}}_{g=1,2,3}(W_3, \mu_3)$  (defined in [6]) is the moduli of families

$$(3-2) \quad \xi = [\Sigma \subset \mathcal{C}, (\mathcal{L}_i, \rho_i)_{i=1}^3]$$

such that  $\Sigma \subset \mathcal{C}$  is a family of genus-one 3–pointed twisted nodal curves, each marking is a stacky point of automorphism group  $\mu_3$ ,  $\rho_i : \mathcal{L}_i^{\otimes 3} \cong \omega_{\mathcal{C}}^{\log}$  are isomorphisms together with isomorphisms  $\mathcal{L}_i \cong \mathcal{L}_1$  for  $i = 2$  and  $3$  understood, and the monodromy of  $\mathcal{L}_1$  along  $\Sigma_i \subset \Sigma$  is  $\frac{3-1}{3}$ .<sup>2</sup> Because of the isomorphisms  $\mathcal{L}_i \cong \mathcal{L}_1$ , we have the canonical isomorphism

$$\mathcal{W}_3 := \overline{\mathcal{M}}_{1,2^3}^{1/3} \cong \overline{\mathcal{M}}_{1,2^3}(W_3, \mu_3),$$

where we recall that  $\mathcal{W}_3$  parametrizes families of  $\xi = [\Sigma \subset \mathcal{C}, \mathcal{L}, \rho]$  with objects  $\Sigma, \mathcal{C}, \mathcal{L}$  and  $\rho$  as before.

Let

$$[\overline{\mathcal{M}}_{1,2^3}(W_3, \mu_3)^p]^{\text{vir}} \in A_* \overline{\mathcal{M}}_{1,2^3}(W_3, \mu_3)$$

be the FJRW invariant of the pair  $(W_3, \mu_3)$ , which is defined in [6] as the cosection localized virtual cycles of the moduli stack  $\overline{\mathcal{M}}_{1,2^3}(W_3, \mu_3)^p$ , parametrizing

$$\xi = \{(\mathcal{C}, \Sigma, \mathcal{L}_1, \dots, \varphi_1, \varphi_2, \varphi_3) \mid (\mathcal{C}, \Sigma, \mathcal{L}_1, \dots) \in \overline{\mathcal{M}}_{1,2^3}(W_3, \mu_3) \text{ and } \varphi_i \in \Gamma(\mathcal{L}_i)\}.$$

We let

$$[\overline{\mathcal{M}}_{1,2^3}^{1/3,p}]^{\text{vir}} \in A_* \overline{\mathcal{M}}_{1,2^3}^{1/3}$$

be the similarly defined cosection localized virtual cycle.

**Lemma 9** *We have the identity*

$$(3-3) \quad [\overline{\mathcal{M}}_{1,2^3}(W_3, \mu_3)^p]^{\text{vir}} = ([\overline{\mathcal{M}}_{1,2^3}^{1/3,p}]^{\text{vir}})^3 \in A^3 \mathcal{W}_3 \equiv A_0 \mathcal{W}_3.$$

**Proof** First, we have the Cartesian product

$$\begin{array}{ccc} \overline{\mathcal{M}}_{1,2^3}(x^3, \mu_3)^p \times \overline{\mathcal{M}}_{1,2^3}(x^3, \mu_3)^p & \longleftarrow & \overline{\mathcal{M}}_{1,2^3}(x^3 + y^3, (\mu_3)^2)^p \\ \downarrow & & \downarrow \\ \overline{\mathcal{M}}_{1,2^3}(x^3, \mu_3) \times \overline{\mathcal{M}}_{1,2^3}(x^3, \mu_3) & \xleftarrow{f} & \overline{\mathcal{M}}_{1,2^3}(x^3 + y^3, (\mu_3)^2) \end{array}$$

where the morphism  $f$  sends  $(\mathcal{C}, \Sigma, \mathcal{L}_1, \mathcal{L}_2)$  to

$$((\mathcal{C}, \Sigma, \mathcal{L}_1), (\mathcal{C}, \Sigma, \mathcal{L}_2)).$$

Applying [6, Theorem 4.11], we get that

$$(3-4) \quad [\overline{\mathcal{M}}_{1,2^3}(x^3 + y^3, (\mu_3)^2)^p]^{\text{vir}} = f^*([\overline{\mathcal{M}}_{1,2^3}(x^3, \mu_3)^p]^{\text{vir}} \times [\overline{\mathcal{M}}_{1,2^3}(x^3, \mu_3)^p]^{\text{vir}}).$$

<sup>2</sup>Our convention is that for  $\mathcal{C} = [\mathbb{A}^1/\mu_r]$  and an invertible sheaf of  $\mathbb{C}_{\mathcal{C}}$ –modules having monodromy  $a/r \in [0, 1)$  at  $[0]$ , locally the sheaf takes the form  $\mathbb{C}_{\mathbb{A}^1}(a[0])/\mu_r$ .



Now let

$$g: \overline{\mathcal{M}}_{1,2^3}(x^3 + y^3, \mu_3) = \overline{\mathcal{M}}_{1,2^3}(x^3, \mu_3) \rightarrow \overline{\mathcal{M}}_{1,2^3}(x^3 + y^3, (\mu_3)^2)$$

be the diagonal morphism. Then

$$f \circ g: \overline{\mathcal{M}}_{1,2^3}(x^3, \mu_3) \rightarrow \overline{\mathcal{M}}_{1,2^3}(x^3, \mu_3) \times \overline{\mathcal{M}}_{1,2^3}(x^3, \mu_3)$$

is the diagonal morphism. As  $g$  is étale and proper, we conclude

$$(3-5) \quad [\overline{\mathcal{M}}_{1,2^3}(x^3 + y^3, \mu_3)^p]^{\text{vir}} = g^*[\overline{\mathcal{M}}_{1,2^3}(x^3 + y^3, (\mu_3)^2)^p]^{\text{vir}}.$$

Combined with (3-4) and (3-5), we obtain

$$[\overline{\mathcal{M}}_{1,2^3}(x^3 + y^3, \mu_3)^p]^{\text{vir}} = (f \circ g)^*([\overline{\mathcal{M}}_{1,2^3}(x^3, \mu_3)^p]^{\text{vir}} \times [\overline{\mathcal{M}}_{1,2^3}(x^3, \mu_3)^p]^{\text{vir}}),$$

which is  $([\overline{\mathcal{M}}_{1,2^3}(x^3, \mu_3)^p]^{\text{vir}})^2$ . Here we have used that  $\overline{\mathcal{M}}_{1,2^3}(x^3, \mu_3)$  is smooth. Repeating the same argument to go from  $x^3 + y^3$  to  $W_3$  proves the lemma.  $\square$

**3.1.1 Cosection localized virtual cycles** Let  $\mathcal{W}$  be a smooth DM stack, with a complex of locally free sheaves of  $\mathbb{O}_{\mathcal{W}}$ -modules

$$(3-6) \quad \mathcal{E}^\bullet := [\mathbb{O}_{\mathcal{W}}(E_0) \xrightarrow{s} \mathbb{O}_{\mathcal{W}}(E_1)]$$

of rank  $a_0$  and  $a_1 = a_0 + 1$ , respectively. Let  $\pi: E_0 \rightarrow \mathcal{W}$  be the projection; the section  $s$  induces a section  $\tilde{s} \in \Gamma(\tilde{E}_1)$  of the pullback bundle  $\tilde{E}_1 := \pi^* E_1$ . We define

$$(3-7) \quad \mathcal{M} := (\tilde{s} = 0) \subset E_0.$$

**Assumption 10** We assume  $\mathcal{D} = (\ker s \neq 0) \subset \mathcal{W}$  is a smooth Cartier divisor;  $\text{Im}(s|_{\mathcal{D}})$  is a rank- $(a_0 - 1)$  subbundle of  $E_1|_{\mathcal{D}}$ .

Because  $\mathcal{D}$  is a smooth Cartier divisor, we can find a vector bundle  $F$  on  $\mathcal{W}$  fitting into

$$(3-8) \quad \mathbb{O}_{\mathcal{W}}(E_0) \xrightarrow{\eta_1} \mathbb{O}_{\mathcal{W}}(F) \xrightarrow{\eta_2} \mathbb{O}_{\mathcal{W}}(E_1)$$

so that  $\eta_1|_{\mathcal{W}-\mathcal{D}} = s|_{\mathcal{W}-\mathcal{D}}$  is an isomorphism,  $F \rightarrow E_1$  is a subvector bundle, and  $s = \eta_2 \circ \eta_1$ .

We let  $\mathcal{A} = H^1(\mathcal{E}^\bullet)$ . By Assumption 10, it fits into the exact sequence

$$(3-9) \quad 0 \rightarrow \mathbb{O}_{\mathcal{W}}(E_0) \xrightarrow{\phi} \mathbb{O}_{\mathcal{W}}(F) \rightarrow \mathcal{A} \rightarrow 0.$$

Further, there is a line bundle  $A$  on  $\mathcal{D}$  such that  $\mathcal{A} = \mathbb{O}_{\mathcal{D}}(A)$ . In the following, we will view  $c_1(A)$  as an element of  $A^1\mathcal{D}$ . Then for the inclusion  $\iota: \mathcal{D} \rightarrow \mathcal{W}$ , we have  $\iota_*c_1(A) \in A^2\mathcal{W}$ . Since  $A$  is a line bundle on  $\mathcal{D}$ , we have  $c_1(\mathcal{A}) = [\mathcal{D}]$ , thus:

**Lemma 11**  $c_1(E_1 - F) = c_1(E_1 - E_0) - [D]$ .

We let  $J \subset E_0|_{\mathcal{D}}$  be the kernel of  $s|_{\mathcal{D}}$ ; by our assumption it is a line bundle on  $\mathcal{D}$ . We relate  $A$  to  $J$ :

**Lemma 12** *Let the situation be as stated and assume Assumption 10. Then  $A \cong J(\mathcal{D})$ .*

**Proof** Let  $\mathcal{J} = \mathbb{O}_{\mathcal{D}}(J)$  and let  $\eta = \ker\{\mathbb{O}_{\mathcal{D}}(F) \rightarrow \mathcal{A}\}$ . Then  $\eta$  fits into the exact sequences

$$0 \rightarrow \mathbb{O}_{\mathcal{D}}(J) \rightarrow \mathbb{O}_{\mathcal{D}}(E_0) \rightarrow \eta \rightarrow 0 \quad \text{and} \quad 0 \rightarrow \eta \rightarrow \mathbb{O}_{\mathcal{D}}(F) \rightarrow \mathbb{O}_{\mathcal{D}}(A) \rightarrow 0.$$

Let  $\xi \in \mathbb{O}_{\mathcal{D}}(J)$  be any (local) section. Let  $\tilde{\xi} \in \mathbb{O}_{\mathcal{W}}(E_0)$  be a lift of the image of  $\xi$  in  $\mathbb{O}_{\mathcal{D}}(E_0)$ . Then  $\phi(\tilde{\xi}) \in \mathbb{O}_{\mathcal{W}}(F)$ , where  $\phi$  is as in (3-9). Clearly,  $\phi(\tilde{\xi})|_{\mathcal{D}} = 0$ . Let  $t \in \mathbb{O}_{\mathcal{W}}(\mathcal{D})$  be the defining equation of  $\mathcal{D}$ . Then  $t^{-1}\phi(\tilde{\xi}) \in \mathbb{O}_{\mathcal{W}}(F)(-\mathcal{D})$ . We define  $\varphi(\xi)$  to be the image of  $t^{-1}\phi(\tilde{\xi})$  in  $\mathbb{O}_{\mathcal{D}}(A(-\mathcal{D}))$  under the composition

$$\mathbb{O}_{\mathcal{W}}(F)(-\mathcal{D}) \rightarrow \mathbb{O}_{\mathcal{D}}(F(-\mathcal{D})) \rightarrow \mathbb{O}_{\mathcal{D}}(A(-\mathcal{D})).$$

It is direct to check that  $\varphi: \mathbb{O}_{\mathcal{D}}(J) \rightarrow \mathbb{O}_{\mathcal{D}}(A(-\mathcal{D}))$  is a well-defined homomorphism of sheaves, and is an isomorphism. □

This way,  $\mathcal{M}$  (see (3-7)) is a union of  $\mathcal{W} \subset E_0$  (the 0-section) and the subbundle  $J \subset E_0|_{\mathcal{D}} \subset E_0$ . As  $\mathcal{M} \subset E_0$  is defined by the vanishing of  $\tilde{s}$ , it comes with a normal cone

$$(3-10) \quad \mathcal{C} := \lim_{t \rightarrow 0} \Gamma_{t^{-1}\tilde{s}} \subset \tilde{E}_1|_{\mathcal{M}}.$$

**Lemma 13** *With Assumption 10, the cone  $\mathcal{C} \subset \tilde{E}_1|_{\mathcal{M}}$  is a union of two subvector bundles  $\eta_2(F) \subset E_1$  and  $\pi^*\eta_2(F)|_J \subset \tilde{E}_1|_J$ .*

**Proof** This is local, thus without loss of generality we can assume  $a_0 = 1$ . Since  $\mathcal{D} = (s = 0)$  is a smooth divisor in  $\mathcal{W}$ , near a point at  $\mathcal{D}$  we can give  $\mathcal{W}$  an analytic neighborhood  $U$  with chart  $(u, x)$ , where  $u$  is a multivariable, so that  $\mathcal{D} = (x = 0)$  and  $s|_U: E_0|_U \rightarrow E_1|_U$  takes the form

$$s|_U = (x, 0): \mathbb{O}_U \rightarrow \mathbb{O}_U \oplus \mathbb{O}_U^{\oplus(a_1-1)} \cong \mathbb{O}_U(E_1).$$

We let  $y$  be the fiber-direction coordinate of  $E_0|_U$ . Then  $\pi^{-1}(U) \subset E_0$  has the chart  $(u, x, y)$ , with  $\tilde{s}|_{\pi^{-1}(U)} = (xy, 0)$ . Therefore, the cone  $\mathcal{C} \subset E_0$  over  $\pi^{-1}(U)$  is the line bundle

$$\mathbb{O}_{\pi^{-1}(U) \cap \mathcal{M}} \subset \mathbb{O}_{\pi^{-1}(U) \cap \mathcal{M}} \oplus \mathbb{O}_{\pi^{-1}(U) \cap \mathcal{M}}^{\oplus(a_1-1)} \cong \mathbb{O}_{\pi^{-1}(U) \cap \mathcal{M}}(\tilde{E}_1). \quad \square$$

**Assumption 14** We assume that there is a homomorphism (cosection)

$$\sigma: \tilde{E}_1|_{\mathcal{M}} \rightarrow \mathbb{C}_{\mathcal{M}}$$

such that  $\sigma|_{\mathcal{W}} = 0$ , and  $\pi^*\eta_2(F)|_J$  lies in the kernel of  $\sigma$ .

Let

$$[\mathcal{M}]_{\sigma}^{\text{vir}} := 0_{\sigma}^![\mathcal{C}] \in A^{a_1-a_0}\mathcal{W}$$

be the image of  $[\mathcal{C}]$  under the cosection localized Gysin map.

**Proposition 15** *Let the situation be as mentioned, and suppose the cosection  $\sigma$  is fiberwise homogeneous of degree  $e$ . Then*

$$[\mathcal{M}]_{\sigma}^{\text{vir}} = -c_1(E_0 - E_1) - (e + 1)[\mathcal{D}] \in A^1\mathcal{W} \quad \text{when } a_1 - a_0 = 1.$$

**Proof** Following the discussion leading to [5, Lemma 6.4], we compactify  $\mathcal{M}$  by compactifying  $J$  by  $\mathcal{P} := \mathbb{P}_{\mathcal{D}}(J \oplus 1)$ . Let  $\mathcal{D}_{\infty} = \mathbb{P}_{\mathcal{D}}(J \oplus 0) \subset \mathbb{P}_{\mathcal{D}}(J \oplus 1)$ . Then  $\mathcal{P} = J \cup \mathcal{D}_{\infty}$ , and  $\bar{\mathcal{M}} = \mathcal{P} \cup \mathcal{W}$ . Let  $\bar{\pi}: \mathcal{P} \rightarrow \mathcal{D}$  be the tautological projection. Then  $\pi^*F|_J \subset \tilde{E}_1|_J$  extends to  $\bar{\pi}^*F \subset \bar{\pi}^*E_1$ , a subbundle. Because  $\sigma$  is fiberwise homogeneous of degree  $e$ , we see that  $\sigma|_J: \tilde{E}_1|_J = \bar{\pi}^*E_1|_J \rightarrow \mathbb{C}_J$  extends to a homomorphism

$$\bar{\sigma}: \bar{\pi}^*E_1(-e\mathcal{D}_{\infty}) \rightarrow \mathbb{C}_{\mathcal{P}},$$

which is surjective along  $\mathcal{D}_{\infty} = \bar{\mathcal{M}} - \mathcal{M}$ .

We let  $\bar{\pi}^*F(-e\mathcal{D}_{\infty}) \subset \bar{\pi}^*E_1(-e\mathcal{D}_{\infty})$  be the associated twisting of the subbundle  $\bar{\pi}^*F \subset \bar{\pi}^*E_1$ . Applying [5, Lemma 6.4], we conclude that

$$(3-11) \quad 0_{\sigma}^![\mathcal{C}] = 0_{E_1}^![F] + \bar{\pi}_*(0_{\bar{\pi}^*E_1(-e\mathcal{D}_{\infty})}^![\bar{\pi}^*F(-e\mathcal{D}_{\infty})]).$$

When  $a_1 - a_0 = 1$ ,

$$0_{\bar{\pi}^*E_1(-e\mathcal{D}_{\infty})}^![\bar{\pi}^*F(-e\mathcal{D}_{\infty})] = c_1(\bar{\pi}^*(E_1/F)(-e\mathcal{D}_{\infty})) = \bar{\pi}^*c_1(E_1/F) - e[\mathcal{D}_{\infty}].$$

Thus  $\bar{\pi}_*(0_{\bar{\pi}^*E_1(-2\mathcal{D}_{\infty})}^![\bar{\pi}^*F(-e\mathcal{D}_{\infty})]) = -e[\mathcal{D}]$ . Combined with Lemma 11, the proposition follows. □

### 3.2 Applying to the FJRW invariant

We let  $\mathcal{M} = \bar{\mathcal{M}}_{1,2^3}^{1/3,P}$ . We claim that there is a complex of vector bundle as in (3-6) so that  $\mathcal{M}$  is defined as in (3-7), and there is a cosection  $\sigma$  satisfying Assumption 14.

Indeed, let  $\overline{\mathcal{M}}_{1,2,3}$  be the moduli of 3–pointed genus-one twisted curves where all markings are  $\mu_3$  stacky. Then the forgetful morphism  $q: \overline{\mathcal{M}}_{1,2,3}^{1/3} \rightarrow \overline{\mathcal{M}}_{1,2,3}$  is finite and smooth. Furthermore, let  $(\Sigma \subset \mathcal{C}, \mathcal{L})$  be the universal family of  $\overline{\mathcal{M}}_{1,2,3}^{1/3}$ . Then  $(\Sigma \subset \mathcal{C})$  is the pullback of the universal family of  $\overline{\mathcal{M}}_{1,2,3}$ , and a standard method shows that we can find a complex  $\mathcal{E}^\bullet = [s: \mathcal{O}_{\mathcal{C}}(E_0) \rightarrow \mathcal{O}_{\mathcal{C}}(E_1)]$  of locally free sheaves such that  $\mathcal{E}^\bullet = R^\bullet \pi_* \mathcal{L}$ , in the derived category. Here  $\pi: \mathcal{C} \rightarrow \overline{\mathcal{M}}_{1,2,3}^{1/3}$  is the projection. Then a standard argument shows that this complex  $\mathcal{E}^\bullet$  is the desired one, giving a canonical embedding of  $\mathcal{M} = \overline{\mathcal{M}}_{1,2,3}^{1/3,P}$  into the total space of  $E_0$ , as the vanishing locus of  $\tilde{s}$ .

The choice of cosection  $\sigma$  is induced by  $\mathcal{O}_{\mathcal{W}}(E_1) \rightarrow H^1(\mathcal{E}^\bullet)$ , following that in [6], and satisfies Assumption 14. Finally, following the construction of  $[\overline{\mathcal{M}}_{1,2,3}^{1/3,P}]^{\text{vir}}$ , we see that

$$[\mathcal{M}]_\sigma^{\text{vir}} = [\overline{\mathcal{M}}_{1,2,3}^{1/3,P}]^{\text{vir}}.$$

We skip the details here.

We next check that Assumption 10 holds in this case.

**Lemma 16** *Let  $\mathcal{D} \subset \mathcal{W} (= \overline{\mathcal{M}}_{1,2,3}^{1/3})$  be the locus where  $R^0 \pi_* \mathcal{L}$  is nontrivial. Then it is a smooth divisor of  $\mathcal{W}$ .*

**Proof** Let  $(\mathcal{C}, \Sigma, \mathcal{L}) \in \mathcal{W}$  be a closed point such that  $H^0(\mathcal{L}) \neq 0$ . Then a direct calculation shows that  $\mathcal{C}$  has a node  $q \in \mathcal{C}$  that separates  $\mathcal{C}$  into two irreducible components  $\mathcal{E}$  and  $\mathcal{R}$ , so that  $q \subset \mathcal{E}$  is a 1–pointed (twisted) elliptic curve with  $h^0(\mathcal{L}|_{\mathcal{E}}) = 1$ , and  $q \cup \Sigma \subset \mathcal{R}$  is a 4–pointed (twisted) rational curve. The same argument shows that the converse is also true. Therefore, letting  $\mathcal{D} \subset \overline{\mathcal{M}}_{1,2,3}^{1/3}$  be the closed locus (see Figure 2) where  $R^0 \pi_* \mathcal{L}$  is nontrivial,  $R^0 \pi_* \mathcal{L}$  is a locally free sheaf of  $\mathbb{C}_{\mathcal{D}}$ –modules. Equivalently, letting

$$\pi_{\mathcal{D}}: \mathcal{C}_{\mathcal{D}} = \mathcal{C} \times_{\overline{\mathcal{M}}_{1,2,3}^{1/3}} \mathcal{D} \rightarrow \mathcal{D}$$

be the projection, this says that  $\pi_{\mathcal{D}*}(\mathcal{L}|_{\mathcal{C}_{\mathcal{D}}})$  is a rank-one locally free sheaf of  $\mathbb{C}_{\mathcal{D}}$ –modules. Let  $t$  be a local section of this sheaf. Then  $(t = 0) \subset \mathcal{C}_{\mathcal{D}}$  becomes a family of rational curves, the family that contains all those  $q \cup \Sigma \subset \mathcal{R}$  mentioned. This shows that  $\mathcal{C}_{\mathcal{D}} \rightarrow \mathcal{D}$  is exactly the subfamily in  $\overline{\mathcal{M}}_{1,2,3}^{1/3}$  that can be decomposed into 1–pointed twisted elliptic curves  $q \subset \mathcal{E}$  with  $h^0(\mathcal{L}|_{\mathcal{E}}) = 1$ , and 4–pointed twisted rational curves  $q \cup \Sigma \subset \mathcal{R}$ . This implies that  $\mathcal{D}$  is a smooth divisor of  $\mathcal{W} = \overline{\mathcal{M}}_{1,2,3}^{1/3}$ . □

We illustrate the divisor  $\mathcal{D}$  by a decorated graph in Figure 2. A generic point in  $\mathcal{D}$  consists a nodal curve with a genus-one component ( $g = 1$ ) and a genus-zero component

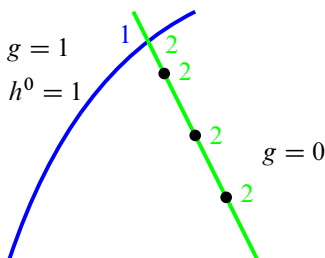

Figure 2: The divisor  $\mathcal{D}$  on the moduli stack  $\mathcal{W} = \overline{\mathcal{M}}_{1,2^3}^{1/3}$ .

( $g = 0$ ). The monodromy along the node is  $\frac{1}{3}$  on the genus-one component and  $\frac{2}{3}$  on the genus-zero component. Here  $h^0 = 1$  is the rank of  $R^0\pi_*\mathcal{L}$  restricted to the genus-one component.

Finally, to apply Proposition 15 we need to show that the cosection is fiberwise homogeneous of degree  $e = 2$ . This follows from the definition of the cosection in [6], and the degree  $e$  is  $3 - 1$ , where 3 is the denominator of  $\frac{1}{3}$ . Applying Proposition 15, we obtain:<sup>3</sup>

**Corollary 17** *The Witten top Chern class of the moduli of three-spin curves  $\overline{\mathcal{M}}_{1,2^3}^{1/3}$  is*

$$(3-12) \quad [\overline{\mathcal{M}}_{1,2^3}^{1/3,p}]^{\text{vir}} = -c_1(R^*\pi_*\mathcal{L}) - 3[\mathcal{D}].$$

Applying Lemma 9, we get

$$(3-13) \quad \Theta_{1,3} = \text{deg}[\overline{\mathcal{M}}_{1,2^3}(W_3, \mu_3)^p]^{\text{vir}} = \text{deg}([\overline{\mathcal{M}}_{1,2^3}^{1/3,p}]^{\text{vir}})^3.$$

Thus the FJRW invariant  $\Theta_{1,3}$  in Proposition 8 can be calculated explicitly from the triple self-intersection of the cycle (3-12). Note that the first term in (3-12) can be calculated by Chiodo’s formula [9]. The calculation is subtle and lengthy, and the details are given in [38]. An alternative approach to computing this invariant using the mixed-spin- $P$  fields method developed in [7; 8] is also presented in [38].

## 4 LG/CY correspondence for the Fermat cubic

This section is devoted to proving Theorem 3. We shall show that the GW/FJRW correlation functions as Fourier/Taylor expansions of the same quasimodular form

<sup>3</sup>This formula is a special case of a sequence of formulae for moduli of  $r$ -spin curves, conjectured by Janda (personal communication, 2019).

around different points (the infinity cusp and an interior point on the upper half-plane) which are related by the so-called holomorphic Cayley transformation that we shall introduce.

#### 4.1 Cayley transformation and elliptic expansions of quasimodular forms

It is well known that the Eisenstein series  $E_2(\tau)$  is not modular; however, its non-holomorphic modification

$$(4-1) \quad \widehat{E}_2(\tau, \bar{\tau}) := E_2(\tau) - \frac{3}{\pi \operatorname{Im}(\tau)}$$

is modular. The map (called modular completion) sending  $E_2$  to  $\widehat{E}_2$ , and  $E_4$  and  $E_6$  to themselves, is an isomorphism from  $\widetilde{M}_*(\Gamma)$  to the ring of almost-holomorphic modular forms

$$(4-2) \quad \widehat{M}_*(\Gamma) := \mathbb{C}[\widehat{E}_2, E_4, E_6].$$

More precisely, for any quasimodular form  $f(\tau) \in \widetilde{M}_*(\Gamma)$  of weight  $k$ , we denote by  $\widehat{f}(\tau, \bar{\tau}) \in \widehat{M}_*(\Gamma)$  its modular completion. The function  $\widehat{f}$  can be regarded as a polynomial in the formal variable  $1/\operatorname{Im}(\tau)$ ,

$$(4-3) \quad \widehat{f} = f + \sum_{j=1}^k f_j \left( \frac{1}{\operatorname{Im}(\tau)} \right)^j,$$

with coefficients some holomorphic functions  $f_j$  for  $j = 1, 2, \dots, k$  in  $\tau$ . We call the inverse of the modular completion the *holomorphic limit*. It maps the almost-holomorphic modular form  $\widehat{f}$  in (4-3) to its degree-zero term  $f$  in the formal variable  $1/\operatorname{Im}(\tau)$ .

For any point  $\tau_* \in \mathbb{H}$ , we form the Cayley transform from  $\mathbb{H}$  to a disk  $\mathbb{D}$  (of appropriate radius determined by  $\tau_*$  and  $c \neq 0$ ),

$$(4-4) \quad \tau \mapsto s(\tau) := c2\pi\sqrt{-1}(\tau_* - \bar{\tau}_*) \frac{\tau - \tau_*}{\tau - \bar{\tau}_*} \in \mathbb{D}.$$

It is biholomorphic and we denote its inverse by  $\tau(s)$ .

Following [57], in [50] we defined a Cayley transformation  $\mathcal{C}_{\tau_*}$  based on the action (4-4) on the space of almost-holomorphic modular forms; it maps the almost-holomorphic modular form  $\widehat{f} \in \widehat{M}_*(\Gamma)$  to

$$(4-5) \quad \mathcal{C}_{\tau_*}(\widehat{f})(s, \bar{s}) := (2\pi\sqrt{-1}c)^{-k/2} \left( \frac{\tau(s) - \bar{\tau}_*}{\tau_* - \bar{\tau}_*} \right)^k \widehat{f}(\tau(s), \bar{\tau}(s)).$$

This gives a natural way to expand an almost-holomorphic modular form near  $\tau = \tau_*$ .

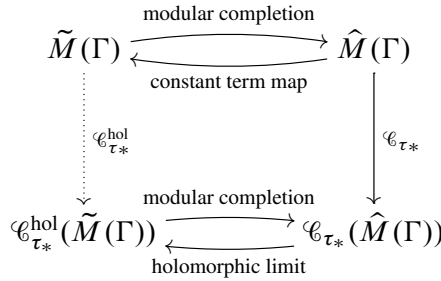

Figure 3: Cayley transformation on quasimodular and almost-holomorphic modular forms.

A similar notion of holomorphic limit can be defined near the interior point  $\tau_*$ . Computationally, this amounts to taking the degree-zero term in the  $\bar{s}$ -expansion of (4-5) (now regarded as a real-analytic function in  $s$  and  $\bar{s}$ ) using the structure (4-3). This procedure induces a transformation  $\mathcal{C}_{\tau_*}^{\text{hol}}$  on quasimodular forms. We will call the transformation  $\mathcal{C}_{\tau_*}^{\text{hol}}$  the *holomorphic Cayley transformation*. This transformation can be shown to respect the differential ring isomorphism between the differential ring of quasimodular forms and the differential ring of almost-holomorphic modular forms. We illustrate the construction by the commutative diagram in Figure 3. See [50] for details.

We are mainly concerned with the expansions of the quasimodular form  $E_2$  around the infinity cusp  $\sqrt{-1}\infty$  and the elliptic points

$$(4-6) \quad \tau_* = -\frac{1}{2\pi\sqrt{-1}}\Gamma\left(\frac{1}{d}\right)\Gamma\left(1-\frac{1}{d}\right)e^{-\pi\sqrt{-1}/d} \quad \text{for } d \in \{3, 4, 6\}.$$

For the Fermat cubic polynomial case  $d = 3$ , in (4-4) we take

$$(4-7) \quad c = \frac{1}{2\pi\sqrt{-1}}\frac{\Gamma(1/d)}{\Gamma(1-1/d)^2}e^{-\pi\sqrt{-1}/d}.$$

The choices in (4-6) and (4-7) then lead to the rational expansion of  $E_2$  around  $\tau_*$ :

$$(4-8) \quad \mathcal{C}_{\tau_*}^{\text{hol}}(E_2) = -\frac{1}{9}s^2 - \frac{1}{1215}s^5 - \frac{1}{459270}s^8 + \dots$$

The other cases,  $d = 4, 6$ , are similar. All of these computations are easy following those in [50].

### 4.2 LG/CY correspondence

We consider the elliptic points (4-6) and the value (4-7) for  $c$  in (4-4). Theorem 3 then follows from:

**Theorem 18** Consider the LG space  $([\mathbb{C}^3 / \langle J_\delta \rangle], W)$  given by (1-2) and (1-3), with  $d = 3$ .

(i) The genus-one GW correlation function is

$$(4-9) \quad -24 \langle \omega \rangle_{1,1}^{\mathcal{E}_d}(q) = E_2(q).$$

(ii) The GW correlation functions  $\langle \dots \rangle_{g,n}^{\mathcal{E}_d}$  are quasimodular forms in the ring  $\mathbb{C}[E_2, E'_2, E''_2]$ .

(iii) The genus-one FJRW correlation function  $\langle \phi \rangle_{1,1}^{W_d}(s)$  is the Taylor expansion of  $-\frac{1}{24}E_2$  around the elliptic point

$$\tau_* = -\frac{\sqrt{-1}}{\sqrt{3}} \exp\left(\frac{2\pi\sqrt{-1}}{3}\right) \in \mathbb{H};$$

that is,

$$(4-10) \quad \langle \phi \rangle_{1,1}^{W_d}(s) = \mathcal{C}_{\tau_*}^{\text{hol}}(\langle \omega \rangle_{1,1}^{\mathcal{E}_d}(q)).$$

(iv) The FJRW correlation functions  $\langle \dots \rangle_{g,n}^{W_d}$  are holomorphic Cayley transformations of quasimodular forms in the ring

$$\mathbb{C}[\mathcal{C}_{\tau_*}^{\text{hol}}(E_2), \mathcal{C}_{\tau_*}^{\text{hol}}(E'_2), \mathcal{C}_{\tau_*}^{\text{hol}}(E''_2)]$$

such that

$$\mathcal{C}_{\tau_*}^{\text{hol}}(\langle \alpha_1 \psi_1^{\ell_1}, \dots, \alpha_n \psi_n^{\ell_n} \rangle_{g,n}^{\mathcal{E}_d}(q)) = \langle \Psi(\alpha_1) \psi_1^{\ell_1}, \dots, \Psi(\alpha_n) \psi_n^{\ell_n} \rangle_{g,n}^{W_d}(s).$$

**Proof** Part (i) is a well-known result in the literature; see eg [43]. We give a new proof based on the Chazy equation. In order to get (4-9), it suffices to check<sup>4</sup>

$$\langle \omega \rangle_{1,1,0}^{\mathcal{E}_d} = -\frac{1}{24} \quad \text{and} \quad \langle \omega \rangle_{1,1,1}^{\mathcal{E}_d} = 1.$$

Both invariants can be obtained by analyzing the virtual fundamental classes explicitly.

Part (ii) is a consequence of (i), the Ramanujan identities (1-11), and Proposition 2.

For (iii), the selection rule [20, Proposition 2.2.8] implies  $\Theta_{1,1} = \Theta_{1,2} = 0$ , as the corresponding moduli spaces are empty. On the other hand, according to Proposition 8,

$$\Theta_{1,3} = \frac{1}{108}.$$

Now we see that as a formal power series in  $s$ , the first three terms of  $\langle \phi \rangle_{1,1}^{W_d}(s)$  match those obtained from  $\mathcal{C}_{\tau_*}^{\text{hol}}(E_2)$  in (4-8). Since both  $\langle \phi \rangle_{1,1}^{W_d}(s)$  and  $\mathcal{C}_{\tau_*}^{\text{hol}}(E_2)$  satisfy the

<sup>4</sup>Note that only two initial conditions are needed to determine a solution from the space of formal power series in  $q = e^{2\pi i \tau}$ .



Chazy equation (1-12), we conclude that

$$\langle\langle\phi\rangle\rangle_{1,1}^{W_d}(s) = -\frac{1}{24} \mathcal{C}_{\tau_*}^{\text{hol}}(E_2).$$

For (iv), we recall that, by  $g$ -reduction, in either theory all nontrivial correlation functions are differential polynomials in the building block  $\langle\langle\omega\rangle\rangle_{1,1}^{\mathcal{E}_d}(q)$  or  $\langle\langle\phi\rangle\rangle_{1,1}^{W_d}(s)$ . Since the holomorphic Cayley transformation respects the differential ring structure and the  $g$ -reduction is independent of the CohFT in consideration, (iv) is a consequence of (iii), the Ramanujan identities (1-11), and Proposition 2.  $\square$

**Remark 19** Propositions 1 and 2 hold for all of the one-dimensional CY weight systems in (1-2) and (1-3). Provided the analogue of Proposition 8 for the  $d = 4$  or 6 case is obtained, the same argument as in the proof of Theorem 18 generalizes straightforwardly.

## 5 Ancestor GW invariants for elliptic curves

The tautological relations used in establishing Proposition 2 are not constructive, and hence not so useful for actual calculation of higher-genus invariants. For this reason, we make use of the beautiful formulae for the descendent GW invariants of elliptic curves given by Bloch and Okounkov [3] and reviewed below. For later use we also discuss the ancestor/descendent correspondence.

### 5.1 Higher-genus descendent GW invariants of elliptic curves

In [43], Okounkov and Pandharipande proved a correspondence between the stationary GW invariants and Hurwitz covers, called Gromov–Witten/Hurwitz correspondence. To be more precise, let  $\langle\langle\prod_{i=1}^N \omega \tilde{\psi}_i^{\ell_i}\rangle\rangle_{g,d}^{\bullet,\mathcal{E}}$  be the disconnected, *stationary*, descendent GW invariant of genus  $g$  and degree  $d$  (the number  $N$  of markings is self-explanatory in the notation). Here  $\tilde{\psi}_i$  is the descendent cotangent line class attached to the  $i^{\text{th}}$  marking, and the symbol  $\bullet$  stands for disconnected counting. The invariant is called *stationary* as the insertions only involve the descendents of  $\omega$ .

Following [43], we define the  $N$ -point generating function by

$$(5-1) \quad F_N(z_1, \dots, z_N, q) := \sum_{\ell_1, \dots, \ell_N \geq -2} \left\langle\left\langle \prod_{i=1}^N \omega \tilde{\psi}_i^{\ell_i} \right\rangle\right\rangle_g^{\bullet,\mathcal{E}} \prod_{i=1}^N z_i^{\ell_i+1},$$

with the convention

$$\langle\langle\omega \tilde{\psi}^{-2}\rangle\rangle_0^{\bullet,\mathcal{E}}(q) = 1.$$

The GW/Hurwitz correspondence [43, Theorem 5] allows one to rewrite the  $N$ -point generating function  $F_N(z_1, \dots, z_N, q)$  by a beautiful character formula from [3]:

$$(5-2) \quad F_N(z_1, z_2, \dots, z_N, q) = (q)_\infty^{-1} \sum_{\text{all permutations of } z_1, \dots, z_N} \frac{\det M_N(z_1, z_2, \dots, z_N)}{\Theta(z_1 + z_2 + \dots + z_N)}.$$

Here  $M_N(z_1, z_2, \dots, z_N)$  is the matrix where the  $(i, j)$  entry is zero if  $j \neq N$  and  $i > j + 1$  and otherwise is given by

$$\frac{\Theta^{(j-i+1)}(z_1 + \dots + z_{N-j})}{(j-i+1)! \Theta(z_1 + \dots + z_{N-j})} \quad \text{if } j \neq N \quad \text{and} \quad \frac{\Theta^{(N-i+1)}(0)}{(N-i+1)!} \quad \text{if } j = N.$$

Recall that  $\Theta$  is defined to be the prime form

$$(5-3) \quad \begin{aligned} \Theta(z) &= \frac{\vartheta_{(1/2, 1/2)}(z, q)}{\partial_z \vartheta_{(1/2, 1/2)}(z, q)|_{z=0}} = 2\pi \sqrt{-1} \frac{\vartheta_{(1/2, 1/2)}(z, q)}{-2\pi \eta^3} \\ &= 2\pi \sqrt{-1} e^{E_2 z^2 / 24} \sigma(z), \end{aligned}$$

with:

- (i) The Euler function

$$(q)_\infty := \prod_{n=1}^{\infty} (1 - q^n)$$

is related to the Dedekind eta function by  $\eta = q^{1/24} (q)_\infty$ .

- (ii) The Jacobi theta function

$$\vartheta_{(1/2, 1/2)}(z, q) := \sum_{n \in \mathbb{Z}} q^{(1/2)(n+1/2)^2} e^{(n+1/2)z}$$

has characteristic  $(\frac{1}{2}, \frac{1}{2})$ .

- (iii) The Weierstrass  $\sigma$ -function  $\sigma(z)$  satisfies the well-known formula<sup>5</sup> (see [51])

$$(5-4) \quad \sigma(z) = \frac{z}{2\pi \sqrt{-1}} \exp\left(\sum_{k=2}^{\infty} \frac{B_{2k}}{2k(2k)!} z^{2k} E_{2k}\right),$$

where  $B_{2k}$  for  $k \geq 1$  are Bernoulli numbers determined from

$$\frac{x}{e^x - 1} = 1 - \frac{1}{2}x + \sum_{k=1}^{\infty} \frac{B_{2k}}{(2k)!} x^{2k}.$$

<sup>5</sup>Note that the  $z$ -variable here differs from the usual one by a  $2\pi \sqrt{-1}$  factor.

Note that we often omit the subscript  $g$  in the correlation function

$$\left\langle\left\langle \prod_{i=1}^N \omega \tilde{\psi}_i^{\ell_i} \right\rangle\right\rangle_g^{\bullet \mathcal{E}},$$

which can be read off from the degree of the insertion according to the dimension axiom. We shall also omit the argument  $q$  in the functions for ease of notation.

The formula (5-2) provides an effective algorithm for computing the stationary descendent GW invariants. For example, as already computed in [3], one has

$$\begin{aligned} F_1(z_1) &= \frac{1}{(q)_\infty \Theta(z_1)}, \\ (5-5) \quad F_2(z_1, z_2) &= \frac{1}{(q)_\infty \Theta(z_1 + z_2)} (\partial_{z_1} \ln \Theta(z_1) + \partial_{z_2} \log \Theta(z_2)), \\ &\vdots \end{aligned}$$

**Remark 20** Let  $\langle\langle \omega \rangle\rangle^{\circ \mathcal{E}}$  be the generating series of stable maps with connected domains with neither descendent nor ancestor classes. Then one has the well-known formula

$$(5-6) \quad \langle\langle \omega \rangle\rangle^{\circ \mathcal{E}} = -\frac{1}{24} E_2.$$

It is easy to see that

$$(5-7) \quad \langle\langle \omega \rangle\rangle^{\bullet \mathcal{E}} = \langle\langle \omega \rangle\rangle^{\circ \mathcal{E}} \exp(G(q)) \quad \text{and} \quad G = \sum_{d \geq 1} \langle\langle \omega \rangle\rangle_{g=1,d}^{\circ \mathcal{E}} q^d.$$

In this case, by enumerating stable maps with connected domains, one can show that

$$(5-8) \quad q \frac{d}{dq} G = \sum_{d \geq 1} \langle\langle \omega \rangle\rangle_{g=1,d}^{\circ \mathcal{E}} q^d = -q \frac{d}{dq} \log(q)_\infty.$$

Solving this equation and using the initial terms of  $G$ , which can be easily computed, one obtains

$$(5-9) \quad G = -\log(q)_\infty.$$

This then gives

$$(5-10) \quad \langle\langle \omega \rangle\rangle^{\bullet \mathcal{E}} = (q)_\infty^{-1} \langle\langle \omega \rangle\rangle^{\circ \mathcal{E}} = (q)_\infty^{-1} \left(-\frac{1}{24}\right) E_2.$$

More generally, for the one-point GW correlation function, the same reasoning implies that

$$\langle\langle \omega \tilde{\psi}^k \rangle\rangle^{\bullet \mathcal{E}} = (q)_\infty^{-1} \langle\langle \omega \tilde{\psi}^k \rangle\rangle^{\circ \mathcal{E}}.$$

The result (5-9) indicates that one can add an extra contribution from the degree-zero part to  $G$ , whose corresponding moduli is an Artin stack. This contribution can be defined to be  $\log q^{-\frac{1}{24}}$ . In this way, after applying the divisor equation, it yields the contribution  $-\frac{1}{24}$  for the degree-zero part in  $\langle\langle\omega\rangle\rangle^{\circ\mathcal{E}}$ . This definition of the extra contribution for the Artin stack changes  $(q)_\infty$  to  $\eta$ . What one gains from the inclusion of this is the quasimodularity of the GW generating functions. The discrepancy will be further discussed from the viewpoint of ancestor/descendent correspondence below.

It is shown in [3] by manipulating the series expansions that the descendent GW correlation functions are essentially (modulo the issue discussed in Remark 20) quasimodular forms. By induction, the weight of  $(q)_\infty \langle\langle \prod_{i=1}^N \omega \tilde{\psi}_i^{k_i} \rangle\rangle^{\bullet\mathcal{E}}$  is  $\sum (k_i + 2)$ . This can also be seen easily by using (5-3) and (5-4).

## 5.2 Ancestor/descendent correspondence

Since explicit formulae in [3] are available only for descendent GW invariants, while we are mainly concerned with ancestor GW invariants, we shall first exhibit the relation between these two types of GW invariants. The relation between the descendent GW invariants and the ancestor GW invariants are described for general targets in [33, Theorem 1.1]. This is the so-called *ancestor/descendent correspondence*. This correspondence is written down elegantly using a quantization formula of quadratic Hamiltonians in [22, Theorem 5.1].

We summarize some basics of quantization of quadratic Hamiltonians from [22]. Let  $H$  be a vector space of finite rank, equipped with a nondegenerating pairing  $\langle -, - \rangle$ . Let  $H((z))$  be the loop space of the vector space  $H$ , equipped with a symplectic form  $\Omega$  defined by

$$\Omega(f(z), g(z)) := \text{Res}_{z=0} \langle f(-z), g(z) \rangle.$$

Let  $\mathbf{t}_k$  be the collection of variables  $\mathbf{t}_k = \{t_k^\alpha\}_\alpha$  where  $\alpha$  runs over a basis of  $H$ , and  $\mathbf{t}$  be the collection

$$\mathbf{t} = \{\mathbf{t}_0, \mathbf{t}_1, \dots\}.$$

We organize the collection  $\mathbf{t}_k$  into a formal series  $\mathbf{t}_k$ :

$$\mathbf{t}_k(z) = \sum_i t_k^i \alpha_i z^k.$$

Similar notation is used for  $s_k$  and  $s$  below. Introduce the *dilaton shift*

$$(5-11) \quad \mathbf{q}(z) = \mathbf{t}(z) - z\mathbf{1}.$$

We consider an upper-triangular symplectic operator on  $H((z))$ , defined by

$$S(z^{-1}) := 1 + \sum_{i=1}^{\infty} z^{-i} S_i \quad \text{for } S_i \in \text{End}(H).$$

Given an element  $\mathcal{G}(\mathbf{q})$  in a certain Fock space, the quantization operator  $\widehat{S}$  of a symplectic operator  $S$  gives another Fock space element

$$(5-12) \quad (\widehat{S}^{-1}\mathcal{G})(\mathbf{q}) = e^{W(\mathbf{q}, \mathbf{q})/2\hbar} \mathcal{G}([S\mathbf{q}]_+),$$

where  $[S\mathbf{q}]_+$  is the power series truncation of the function  $S(z^{-1})\mathbf{q}(z)$ , and the quadratic form  $W = \sum(W_{k\ell}q_k, q_\ell)$  is defined by

$$\sum_{k, \ell \geq 0} \frac{W_{k, \ell}}{w^k z^\ell} := \frac{S^*(w^{-1})S(z^{-1}) - \text{Id}}{w^{-1} + z^{-1}}.$$

Here Id is the identity operator on  $H((z))$  and  $S^*$  is the adjoint operator of  $S$ .

Following Givental [22, Section 5], for the descendent theory we define a particular symplectic operator  $S_t$  by

$$(5-13) \quad (a, S_t b) := \left\langle a, \frac{b}{z - \psi} \right\rangle =: (a, b) + \sum_{k=0}^{\infty} \langle\langle a, b \tilde{\psi}^k \rangle\rangle_{0,2}^{\circ\mathcal{E}} z^{-1-k}.$$

Now we specialize to the elliptic curve case and write down the quantization formula for the ancestor/descendent correspondence explicitly. Henceforward, we use the following convention:

- Recall  $\{\mathbf{1}, \mathfrak{b}_1, \mathfrak{b}_2, \phi\}$  is a basis of the FJRW state space  $\mathcal{H}(W_d, G_d)$  given in (2-10). We parametrize the ancestor classes  $\mathbf{1}\psi^\ell, \mathfrak{b}_1\psi^\ell, \mathfrak{b}_2\psi^\ell$  and  $\phi\psi^\ell$  by

$$(5-14) \quad s_\ell^0, \quad s_\ell^1, \quad s_\ell^2 \quad \text{and} \quad s_\ell^3.$$

- Recall  $\{\mathbf{1}, e_1, e_2, \omega\}$  is a basis of the cohomology space  $H^*(\mathcal{E})$ . We parametrize the ancestor classes  $\mathbf{1}\psi^\ell, e_1\psi^\ell, e_2\psi^\ell$  and  $\omega\psi^\ell$ , and descendent classes  $\mathbf{1}\tilde{\psi}^\ell, e_1\tilde{\psi}^\ell, e_2\tilde{\psi}^\ell$  and  $\omega\tilde{\psi}^\ell$  by

$$(5-15) \quad t_\ell^0, t_\ell^1, t_\ell^2, t_\ell^3, \quad \text{and} \quad \tilde{t}_\ell^0, \tilde{t}_\ell^1, \tilde{t}_\ell^2, \tilde{t}_\ell^3,$$

respectively.

The total descendent potential of the GW theory of  $\mathcal{E}$  is defined by

$$(5-16) \quad \mathcal{D}^\mathcal{E}(\tilde{\mathbf{t}}) := \exp\left(\sum_{g \geq 0} \hbar^{g-1} \mathcal{F}_g^{\circ\mathcal{E}}(\tilde{\mathbf{t}})\right) := \exp\left(\sum_{g \geq 0} \hbar^{g-1} \sum_{n \geq 0} \langle \tilde{\mathbf{t}}, \dots, \tilde{\mathbf{t}} \rangle_{g,n}^{\circ\mathcal{E}}\right).$$

The total ancestor potential of the GW theory of  $\mathcal{E}$  is defined by

$$\mathcal{A}^\mathcal{E}(\mathbf{t}) := \exp\left(\sum_{g \geq 0} \hbar^{g-1} \mathcal{F}_g^{\circ\mathcal{E}}(\mathbf{t})\right) := \exp\left(\sum_{g \geq 0} \hbar^{g-1} \sum_{\substack{n \geq 0 \\ 2g-2+n > 0}} \langle \mathbf{t}, \dots, \mathbf{t} \rangle_{g,n}^{\circ\mathcal{E}}\right).$$

The total ancestor FJRW potential is defined similarly.

The quantity  $\mathcal{F}_1^{\circ\mathcal{E}}(t)$  is the genus-one primary potential of the GW theory of  $\mathcal{E}$  appearing in  $\mathcal{A}^\mathcal{E}$ , with the parameter  $q = e^t$  keeping track of the degree. By [22, Theorem 5.1], the ancestor/descendent correspondence of the elliptic curve is given by

$$(5-17) \quad \mathcal{D}^\mathcal{E} = e^{\mathcal{F}_1^{\circ\mathcal{E}}(t)} \widehat{S}_t^{-1} \mathcal{A}^\mathcal{E},$$

under the identification  $\tilde{t}_\ell^i = t_\ell^i$ .

According to (5-9), the genus-one potential is

$$\mathcal{F}_1^{\circ\mathcal{E}}(t) = G(q) = \sum_{d \geq 1} \langle \rangle_{1,0,d}^{\circ\mathcal{E}} q^d = -\log(q)_\infty \quad \text{for } q = e^t.$$

Thus we obtain

$$\widehat{S}_t^{-1} \mathcal{A}^\mathcal{E} = e^{-\mathcal{F}_1^{\circ\mathcal{E}}(t)} \mathcal{D}^\mathcal{E} = (q)_\infty \mathcal{D}^\mathcal{E} = (q)_\infty \sum_{g,n \in \mathbb{Z}} \hbar^{g-1} \langle \tilde{\mathbf{t}}, \dots, \tilde{\mathbf{t}} \rangle_{g,n}^{\bullet\mathcal{E}}.$$

A direct calculation of (5-13) shows the restriction of  $S_t$  to the odd cohomology is the identity operator, and the restriction to even cohomology is given by

$$S_t \begin{pmatrix} \mathbf{1} \\ \omega \end{pmatrix} = \begin{pmatrix} 1 & t/z \\ & 1 \end{pmatrix} \begin{pmatrix} \mathbf{1} \\ \omega \end{pmatrix}.$$

Now, we write down an explicit formula for the quantization operator (5-12). The symplectic operator  $S_t$  is given in terms of infinitesimal symplectic operator  $h(t)/z$ :

$$S_t = \exp\left(\frac{h(t)}{z}\right).$$

Here  $h(t) \in \text{End}(H)$  is such that  $h(t)(\mathbf{1}) = t\omega$  if  $h(t)(\omega) = 0$ , and  $h(t)(e_i) = 0$  otherwise. In terms of the Darboux coordinates  $\tilde{q}_k^i$  and  $\tilde{p}_k^i$ , the corresponding quadratic Hamiltonian has the form (see [35, Section 3], for example)

$$P\left(\frac{h(t)}{z}\right) = -t \cdot \frac{1}{2} (\tilde{q}_0^0)^2 - t \sum_{k \geq 0} \tilde{q}_{k+1}^0 \tilde{p}_k^0.$$

Applying the quantization formula, we get

$$(5-18) \quad \widehat{S}_t = \exp\left(\widehat{P\left(\frac{h(t)}{z}\right)}\right) = \exp\left(-t \cdot \frac{1}{2} (\tilde{q}_0^0)^2 - t \sum_{k \geq 0} \tilde{q}_{k+1}^0 \frac{\partial}{\partial \tilde{q}_k^0}\right).$$

As a consequence, we observe that this operator has no influence on the parameter  $\tilde{q}_k^3$  for the descendent  $\omega\tilde{\psi}^k$ . Thus we obtain:

**Proposition 21** *The relation between the stationary descendent invariants and the corresponding ancestor invariants is given by*

$$(5-19) \quad (q)_\infty \left\langle \left\langle \prod_{i=1}^N \omega \tilde{\psi}_i^{\ell_i} \right\rangle \right\rangle_g^{\bullet, \mathcal{E}} = \left\langle \left\langle \prod_{i=1}^N \omega \psi_i^{\ell_i} \right\rangle \right\rangle_g^{\bullet, \mathcal{E}}.$$

Quasimodularity for the correlation functions in the disconnected theory is equivalent to quasimodularity for the connected theory, as one can see by examining the generating series. Hence our Theorem 18(ii) is consistent with the results in [3; 43] about the quasimodularity via the above proposition.

## 6 Higher-genus FJRW invariants for the Fermat cubic

In this section we give several applications of Theorem 3. With the help of the Bloch–Okounkov formula [3], Cayley transformation allows us to compute the FJRW invariants of the Fermat elliptic polynomials at all genera. It also transforms various structures for the GW theory of elliptic curves, such as the holomorphic anomaly equations [42; 43] and Virasoro constraints [44], to those in the corresponding FJRW theory.

### 6.1 Higher-genus ancestor FJRW invariants for the cubic

Consider the Laurent expansion of the  $N$ -point generating function

$$F_N(z_1, z_2, \dots, z_N, q).$$

The Laurent expansion of  $\partial^m \ln \Theta$  is clear from (5-4), while that of  $1/\Theta$  or  $1/\sigma$  can be obtained by applying the Faá di Bruno formula to the exponential term in  $1/\sigma$ , which in the current case is determined by the Bell polynomials in  $-B_{2k} E_{2k}/2k$  for  $k \geq 2$ . However, this only gives the Laurent coefficients in terms of the generators  $E_{2k}$  for  $k \geq 2$ , for the ring of modular forms. The expansions obtained are not particularly useful for our later purpose, which prefers a finite set of generators only.

We proceed as follows. First, the Taylor expansion of the Weierstrass  $\sigma$ -function is given by the classical result [55]

$$(6-1) \quad \sigma = \sum_{m,n \geq 0} \frac{a_{m,n}}{(4m+6n+1)!} \left( \frac{2\pi^4}{3} E_4 \right)^m \left( \frac{16\pi^6}{27} E_6 \right)^n \left( \frac{z}{2\pi\sqrt{-1}} \right)^{4m+6n+1},$$

where the coefficients  $a_{m,n}$  are complex numbers determined from the Weierstrass recursion

$$a_{m,n} = 3(m+1)a_{m+1,n-1} + \frac{16}{3}(n+1)a_{m-2,n+1} - \frac{1}{6}(4m+6n-1)(4m+6n-2)a_{m-1,n},$$

with the initial values  $a_{0,0} = 1$  and  $a_{m,n} = 0$  if either of  $m$  or  $n$  is strictly negative. The Laurent expansion of  $1/\sigma$  is then obtained from the above. It takes the form

$$(6-2) \quad \frac{1}{\sigma} = \sum_{m,n \geq 0} b_{m,n} \left(\frac{2\pi^4}{3} E_4\right)^m \left(\frac{16\pi^6}{27} E_6\right)^n \left(\frac{z}{2\pi\sqrt{-1}}\right)^{4m+6n-1}$$

for some  $b_{m,n}$  that can also be obtained recursively. The formula in (6-1) also gives rise to the Laurent expansion of  $\partial \ln \sigma$ , and hence of  $\partial \ln \Theta$ , in terms of the generators  $E_2$ ,  $E_4$  and  $E_6$ . Together with that of  $\partial \ln \Theta$  it can be used to compute the Laurent expansion of  $F_N(z_1, z_2, \dots, z_N, q)$ .

Consider the  $N = 1$  case first. According to (5-5), the Laurent expansion of  $F_1$  is given by

$$\begin{aligned} F_1(z, q) &= \frac{1}{2\pi\sqrt{-1}(q)_\infty} e^{-E_2/24z^2} \sigma^{-1} \\ &= \frac{1}{z(q)_\infty} \sum_{\ell, m, n \geq 0} \frac{b_{m,n}}{\ell!} \left(-\frac{1}{24} E_2\right)^\ell \left(\frac{1}{24} E_4\right)^m \left(-\frac{1}{108} E_6\right)^n z^{2\ell+4m+6n}. \end{aligned}$$

We therefore arrive at the following relation for the descendent GW correlation functions when  $k \geq -2$ :

$$(6-3) \quad (q)_\infty \langle\langle \omega \tilde{\psi}^k \rangle\rangle^{\bullet \varepsilon} = \sum_{\substack{\ell, m, n \geq 0 \\ 2\ell+4m+6n=k+2}} \frac{b_{m,n}}{\ell!} \left(-\frac{1}{24} E_2\right)^\ell \left(\frac{1}{24} E_4\right)^m \left(-\frac{1}{108} E_6\right)^n.$$

As explained in Proposition 21, this is the corresponding ancestor GW correlation function and is indeed a quasimodular form of weight  $k + 2$ . The first few Laurent coefficients are

$$(6-4) \quad 1, \quad -\frac{1}{24} E_2, \quad \frac{1}{2632} \left(\frac{1}{5} E_4 + \frac{1}{2} E_2^2\right), \quad \dots$$

The other cases are similar. For example, for the  $N = 2$  case from (5-5) we write

$$(q)_\infty F_2(z_1, z_2) = \frac{z_1 + z_2}{\Theta(z_1 + z_2)} \frac{\partial_{z_1} \ln \Theta(z_1) + \partial_{z_2} \log \Theta(z_2)}{z_1 + z_2}.$$

The first term on the right-hand side is expanded as in the  $N = 1$  case, while the second term is expanded using (5-3) and (5-4).



Recall that the derivative on the level of generating series corresponds to the divisor equation in GW theory, and that taking derivatives commutes with Cayley transformations, as shown in [50]. The generators of the differential ring of quasimodular forms are  $E_2, E_4$  and  $E_6$ . To deal with the differential structure, it is in fact more convenient to use the generators  $E_2, E'_2$  and  $E''_2$  for the ring of quasimodular forms as opposed to  $E_2, E_4$  and  $E_6$ . By Theorem 18, the ancestor GW correlation functions satisfy

$$(6-5) \quad \left\langle \left\langle \prod_{i=1}^N \omega \psi_i^{k_i} \right\rangle \right\rangle^{\circ \mathcal{E}} \in \mathbb{C}[E_2, E'_2, E''_2].$$

Theorem 3 applies to the disconnected invariants (by examining the relation between the generating series), and we have

$$(6-6) \quad \langle \phi \psi_1^{k_1}, \dots, \phi \psi_N^{k_N} \rangle_g^{\bullet W_d} = \mathcal{C}_{\tau_*}^{\text{hol}}(\langle \omega \psi_1^{k_1}, \dots, \omega \psi_N^{k_N} \rangle_g^{\bullet \mathcal{E}_d}).$$

Now we can apply Cayley the transformation directly to the disconnected, ancestor GW correlation functions and obtain the disconnected, ancestor FJRW correlation functions. As computed in (4-8), for the  $d = 3$  case we have

$$(6-7) \quad \mathcal{C}_{\tau_*}^{\text{hol}}(E_2) = -\frac{1}{9}s^2 - \frac{1}{1215}s^5 - \frac{1}{459270}s^8 + \dots .$$

Since  $\mathcal{C}_{\tau_*}^{\text{hol}}$  respects the product and the differential structure [50], the differential equations (1-11) imply

$$(6-8) \quad \begin{cases} \mathcal{C}_{\tau_*}^{\text{hol}}(E_4) = \mathcal{C}_{\tau_*}^{\text{hol}}(E_2^2 - 12E'_2) = \frac{8}{3}s + \frac{5}{81}s^4 + \frac{2}{5103}s^7 + \dots , \\ \mathcal{C}_{\tau_*}^{\text{hol}}(E_6) = \mathcal{C}_{\tau_*}^{\text{hol}}(E_2 E_4 - 3E'_4) = -8 - \frac{28}{27}s^3 - \frac{7}{405}s^6 + \dots . \end{cases}$$

From (6-3), Proposition 21, Theorem 3 and the degree formula (1-5), we immediately obtain

$$\langle \phi \psi_1^{2g-2} \rangle_{g,1}^{\bullet W_3} = \sum_{\substack{\ell, m, n \geq 0 \\ \ell + 2m + 3n = g}} \frac{b_{m,n}}{\ell!} \left(-\frac{1}{24} \mathcal{C}_{\tau_*}^{\text{hol}}(E_2)\right)^\ell \left(\frac{1}{24} \mathcal{C}_{\tau_*}^{\text{hol}}(E_4)\right)^m \left(-\frac{1}{108} \mathcal{C}_{\tau_*}^{\text{hol}}(E_6)\right)^n .$$

Now Corollary 4 follows from the fact that the disconnected and connected one-point ancestor functions are the same.

### 6.2 Holomorphic anomaly equations

We now describe holomorphic anomaly equations for the FJRW correlation functions. In the rest of the paper we shall only discuss connected invariants, and hence omit the superscript  $\circ$  from the notation.

**6.2.1 HAEs for ancestor GW correlation functions** In [42], Oberdieck and Pixton use the polynomiality of double ramification cycles to prove that the GW cycles  $\Lambda_{g,n}^\varepsilon(\alpha_1, \dots, \alpha_n)$  of the elliptic curves are cycle-valued quasimodular forms. Taking the derivative of those cycles with respect to the second Eisenstein series  $E_2(q)$ , they obtain a holomorphic anomaly equation [42, Theorem 3]. As a consequence, intersecting the corresponding GW cycles with  $\prod_k \psi_k^{\ell_k}$  on  $\overline{\mathcal{M}}_{g,n}$  leads to a holomorphic anomaly equation for the ancestor GW functions

$$\langle\langle \alpha_1 \psi_1^{\ell_1}, \dots, \alpha_n \psi_n^{\ell_n} \rangle\rangle_{g,n}^\varepsilon(q) \in \mathbb{C}[E_2, E_4, E_6].$$

For each subset  $I \subseteq \{1, \dots, n\}$ , we use the convention

$$\alpha_I := \{\alpha_i \psi_i^{\ell_i} \mid i \in I\}.$$

For convenience, we introduce the normalized Eisenstein series

$$C_2(q) = -\frac{1}{24} E_2(q).$$

It is a classical fact that the Eisenstein series  $E_2, E_4$  and  $E_6$  are algebraically independent. We have [42], for the ancestor GW correlation functions,

$$\begin{aligned} (6-9) \quad & \frac{\partial}{\partial C_2} \langle\langle \alpha_1 \psi_1^{\ell_1}, \dots, \alpha_n \psi_n^{\ell_n} \rangle\rangle_{g,n}^\varepsilon(q) \\ &= \langle\langle \alpha_1 \psi_1^{\ell_1}, \dots, \alpha_n \psi_n^{\ell_n}, \mathbf{1}, \mathbf{1} \rangle\rangle_{g-1, n+2}^\varepsilon(q) \\ & \quad + \sum_{\substack{g_1+g_2=g \\ \{1, \dots, n\} = I_1 \sqcup I_2}} \langle\langle \alpha_{I_1}, \mathbf{1} \rangle\rangle_{g_1}^\varepsilon(q) \langle\langle \mathbf{1}, \alpha_{I_2} \rangle\rangle_{g_2}^\varepsilon(q) \\ & \quad - 2 \sum_{i=1}^n \left( \int_\varepsilon \alpha_i \right) \langle\langle \alpha_1 \psi_1^{\ell_1}, \dots, \mathbf{1} \psi_i^{\ell_i+1}, \dots, \alpha_n \psi_n^{\ell_n} \rangle\rangle_{g,n}^\varepsilon(q). \end{aligned}$$

**Remark 22** This equation can also be proved using only the combinatorial results reviewed in Section 5.1; see Pixton [45].

**6.2.2 HAEs for ancestor FJRW correlation functions** Recall that the holomorphic Cayley transformation  $\mathcal{C}_{\tau_*}^{\text{hol}}$  respects the differential ring structure of the set of quasimodular forms. Applying the holomorphic Cayley transformation to (6-9), using Theorem 18 we immediately obtain the following HAE for the ancestor FJRW correlation functions:

**Corollary 23** *Let the notation be as in Theorem 3. For the  $d = 3$  case, the ancestor FJRW correlation function*

$$\langle\langle \alpha_1 \psi_1^{\ell_1}, \dots, \alpha_n \psi_n^{\ell_n} \rangle\rangle_{g,n}^{W_d} \in \mathbb{C}[\mathcal{C}_{\tau_*}^{\text{hol}}(C_2), \mathcal{C}_{\tau_*}^{\text{hol}}(E_4), \mathcal{C}_{\tau_*}^{\text{hol}}(E_6)] \quad \text{for } C_2 = -\frac{1}{24} E_2$$

satisfies

$$\begin{aligned}
 (6-10) \quad & \frac{\partial}{\partial \mathcal{C}_{\tau_*}^{\text{hol}}(C_2)} \langle \alpha_1 \psi_1^{\ell_1}, \dots, \alpha_n \psi_n^{\ell_n} \rangle_{g,n}^{W_d} \\
 &= \langle \alpha_1 \psi_1^{\ell_1}, \dots, \alpha_n \psi_n^{\ell_n}, \mathbf{1}, \mathbf{1} \rangle_{g-1, n+2}^{W_d} + \sum_{\substack{g_1+g_2=g \\ \{1, \dots, n\} = I_1 \sqcup I_2}} \langle \alpha_{I_1}, \mathbf{1} \rangle_{g_1}^{W_d} \langle \mathbf{1}, \alpha_{I_2} \rangle_{g_2}^{W_d} \\
 &\quad - 2 \sum_{i=1}^n \langle \alpha_1 \psi_1^{\ell_1}, \dots, \delta_{\alpha_i}^{\phi} \mathbf{1} \psi_i^{\ell_i+1}, \dots, \alpha_n \psi_n^{\ell_n} \rangle_{g,n}^{W_d}
 \end{aligned}$$

where  $\delta_{\alpha_i}^{\phi}$  is the Kronecker symbol.

### 6.3 Virasoro constraints

Virasoro operators in Gromov–Witten theory were proposed by Eguchi, Hori and Xiong [16] for Fano manifolds, and later extended to more general targets [15; 22]. The famous *Virasoro conjecture* predicts that the total descendent potentials in GW theory are annihilated by the Virasoro operators. It is one of the most fascinating conjectures in GW theory. Despite significant developments in the literature, it remains open for a large category of targets.

The Virasoro conjecture for nonsingular target curves is solved by Okounkov and Pandharipande [44]. In particular, when the target is an elliptic curve, the formulae are particularly simple. To be more explicit, using the coordinates induced by (5-15) and letting

$$(\ell)_n := \ell(\ell + 1) \cdots (\ell + n - 1)$$

be the Pochhammer symbol with the convention  $(\ell)_0 := 1$ , the Virasoro operators  $\{L_k^{\mathcal{E}} \mid k \in \mathbb{Z} \text{ and } k \geq -1\}$  are given by

$$\begin{aligned}
 L_k^{\mathcal{E}} = & -(k + 1)! \frac{\partial}{\partial \tilde{t}_{k+1}^0} + \sum_{\ell \geq 0} \left( (\ell)_{k+1} \tilde{t}_{\ell}^0 \frac{\partial}{\partial \tilde{t}_{k+\ell}^0} + (\ell + 1)_{k+1} \tilde{t}_{\ell}^3 \frac{\partial}{\partial \tilde{t}_{k+\ell}^3} \right) \\
 & + \sum_{\ell \geq 0} \left( (\ell + 1)_{k+1} \tilde{t}_{\ell}^1 \frac{\partial}{\partial \tilde{t}_{k+\ell}^1} + (\ell)_{k+1} \tilde{t}_{\ell}^2 \frac{\partial}{\partial \tilde{t}_{k+\ell}^2} \right).
 \end{aligned}$$

According to [44, Theorem 1], the total descendent GW potential defined in (5-16) is annihilated by these Virasoro operators:

$$L_k^{\mathcal{E}} \mathcal{D}^{\mathcal{E}}(\tilde{\mathbf{t}}) = 0.$$

Recently in [27], using Givental's quantization formula of quadratic Hamiltonians [22], the second author and his collaborator study Virasoro operators in FJRW theory and conjecture that the total ancestor FJRW potential of any admissible LG pair  $(W, G)$  is annihilated by the defining Virasoro operators. Besides various generically semi-simple cases, they also verified the conjecture for the nonsemisimple Fermat cubic pair  $(W_3, \mu_3)$ , using Theorem 3. More explicitly, using the coordinates induced in (5-14), the Virasoro operators  $\{L_k^{W_3, \mu_3} \mid k \in \mathbb{Z} \text{ and } k \geq -1\}$  for the Fermat cubic pair  $(W_3, \mu_3)$  are

$$L_k^{W_3, \mu_3} := -(k+1)! \frac{\partial}{\partial t_k^0} + \sum_{\ell \geq 0} \left( (\ell)_{k+1} s_\ell^0 \frac{\partial}{\partial s_{k+\ell}^0} + (\ell+1)_{k+1} s_\ell^3 \frac{\partial}{\partial s_{k+\ell}^3} \right) + \sum_{\ell \geq 0} \left( (\ell+1)_{k+1} s_\ell^1 \frac{\partial}{\partial s_{k+\ell}^1} + (\ell)_{k+1} s_\ell^2 \frac{\partial}{\partial s_{k+\ell}^2} \right).$$

It is not hard to see that these operators commute with the quantization operator  $\widehat{S}_t^{-1}$  in the ancestor/descendent correspondence formula (5-17) and the holomorphic Cayley transformation  $\mathcal{C}_{\tau_*}^{\text{hol}}$  in Theorem 3. Therefore, Virasoro constraints for the FJRW theory are a consequence of Theorem 3.

**Corollary 24** [27] *The total ancestor FJRW potential of the pair  $(W_3, \mu_3)$  is annihilated by the Virasoro operators  $\{L_k^{W_3, \mu_3}\}$ :*

$$L_k^{W, \mu_3} \mathcal{A}^{W_3, \mu_3}(s) = 0.$$

## Appendix

### A.1 A genus-one formula for the Fermat cubic polynomial

For the examples we study, the connection between modular forms and periods of families of elliptic curve gives rise to nice formulae for the holomorphic Cayley transformation of quasimodular forms in terms of hypergeometric series and Givental's  $I$ -functions. In the following, we shall only consider the  $d = 3$  case, as an example, the other cases are similar.

Let us first recall some facts of quasimodular forms following the exposition in [49]. Let  $\Gamma(3)$  be the level-3 principal congruence subgroup of  $\Gamma = \text{SL}(2, \mathbb{Z})/\{\pm 1\}$ . It is well known that the ring of quasimodular forms (with a certain Dirichlet character) for  $\Gamma(3)$  is generated by

$$A = \theta_{A_2}(2\tau)$$

and

$$(A-1) \quad E = \frac{1}{4}(3E_2(3\tau) + E_2(\tau)),$$

where  $\theta_{A_2}$  is the theta function for the  $A_2$ -lattice. Further, define the quantities (where  $\eta$  is the Dedekind eta function)

$$(A-2) \quad C = 3 \frac{\eta(3\tau)^3}{\eta(\tau)} \quad \text{and} \quad \alpha = \frac{C^3}{A^3}.$$

These quantities satisfy

$$(A-3) \quad A = {}_2F_1\left(\frac{1}{3}, \frac{2}{3}; 1; \alpha\right),$$

and furthermore

$$(A-4) \quad \begin{aligned} A^2 &= \frac{1}{2}(3E_2(3\tau) - E_2(\tau)) = \frac{1}{2\pi\sqrt{-1}} \frac{1}{\alpha(1-\alpha)} \frac{\partial}{\partial\tau} \alpha, \\ E &= \frac{6}{2\pi\sqrt{-1}} \frac{\partial}{\partial\tau} \log A - \frac{2C^3 - A^3}{A}. \end{aligned}$$

Using (A-1), (A-2) and (A-4), we can rewrite the quasimodular form  $E_2$  as

$$(A-5) \quad \begin{aligned} E_2(\tau) &= \frac{12}{2\pi\sqrt{-1}} \frac{\partial}{\partial\tau} \log A - (4\alpha - 1)A^2 \\ &= \frac{1}{2\pi\sqrt{-1}} \frac{\partial}{\partial\tau} (12 \log A + \log(\alpha(1-\alpha)^3)). \end{aligned}$$

In [50] the following was obtained from period calculation. Taking  $\tau_* = 1/(1 - \zeta_3)$  as given in (4-6) and  $c$  as in (4-7), one has

$$\begin{aligned} s(\tau) &= 2\pi\sqrt{-1}c(\tau_* - \bar{\tau}_*) \frac{\tau - \tau_*}{\tau - \bar{\tau}_*} \\ &= -2\pi\sqrt{-1}c(\tau_* - \bar{\tau}_*) \frac{\Gamma(-\frac{1}{3})\Gamma(\frac{2}{3})^2}{\Gamma(\frac{1}{3})^3} (-\alpha)^{-1/3} \frac{{}_2F_1(\frac{2}{3}, \frac{2}{3}; \frac{4}{3}; \alpha^{-1})}{{}_2F_1(\frac{1}{3}, \frac{1}{3}; \frac{2}{3}; \alpha^{-1})}. \end{aligned}$$

Also,

$$\mathcal{C}_{\tau_*}(A) = (2\pi\sqrt{-1}c)^{-1/2} \frac{\Gamma(\frac{1}{3})}{\Gamma(\frac{2}{3})^2} (-\alpha)^{-1/3} F_1\left(\frac{1}{3}, \frac{1}{3}; \frac{2}{3}; \alpha^{-1}\right)$$

and

$$\mathcal{C}_{\tau_*}(C) = (2\pi\sqrt{-1}c)^{-1/2} \frac{\Gamma(\frac{1}{3})}{\Gamma(\frac{2}{3})^2} (-1)^{-1/3} F_1\left(\frac{1}{3}, \frac{1}{3}; \frac{2}{3}; \alpha^{-1}\right).$$

Combining the properties of the holomorphic Cayley transformation, Theorem 18 and (A-5), we immediately get

$$\langle\langle\phi\rangle\rangle_{1,1}^{W_3} = \mathcal{C}_{\tau_*}^{\text{hol}}(\langle\langle\omega\rangle\rangle_{1,1}^{\mathcal{E}}) = c^{-1} \frac{\partial}{\partial s} \left(-\frac{1}{2} \log_2 F_1\left(\frac{1}{3}, \frac{1}{3}; \frac{2}{3}; \alpha^{-1}\right) - \frac{1}{8} \log(1 - \alpha^{-1})\right).$$

In the above GW generating series, the divisor class  $\omega$  which corresponds to the first Chern class of a degree-one line bundle on  $\mathcal{E}$  is used as the insertion. According to the divisor axiom,

$$\langle\langle \rangle\rangle_{1,0}^{\mathcal{E}} = -\log \eta(\tau),$$

up to an additive constant. Results derived for a plane cubic curve  $\mathcal{E}_3$ , such as those in Givental's formalism, use the pullback of the hyperplane class on the ambient space  $\mathbb{P}^2$  as the insertion. The corresponding class  $H$  is related to the one  $\omega$  above by  $H = 3\omega$ . Hence we have, up to an additive constant,

$$\langle\langle \rangle\rangle_{1,0}^{\mathcal{E}_3} = -\log \eta(3\tau),$$

and thus

$$\langle\langle H \rangle\rangle_{1,0}^{\mathcal{E}_3} = -\frac{1}{24} \cdot 3E_2(3\tau).$$

Using (A-1), (A-2) and (A-4), one can rewrite it as

$$\langle\langle H \rangle\rangle_{1,0}^{\mathcal{E}_3} = \frac{1}{2\pi\sqrt{-1}} \frac{\partial}{\partial \tau} \left( -\frac{1}{2} \log_2 F_1\left(\frac{1}{3}, \frac{2}{3}; 1; \alpha\right) - \frac{1}{24} \log(\alpha^3(1-\alpha)) \right).$$

This matches the results in [47; 58] obtained using virtual localization. Its holomorphic Cayley transformation is

$$\mathcal{C}_{\tau_*}^{\text{hol}}(\langle\langle H \rangle\rangle_{1,0}^{\mathcal{E}_3}) = c^{-1} \frac{\partial}{\partial s} \left( -\frac{1}{2} \log_2 F_1\left(\frac{1}{3}, \frac{1}{3}; \frac{2}{3}; \alpha^{-1}\right) - \frac{1}{24} \log(1-\alpha^{-1}) \right).$$

This agrees with the result derived using the wall-crossing method in Guo and Ross [26].

## A.2 Cayley transformation and $I$ -functions

Now we discuss the connection between our formulation of LG/CY correspondence and the original formulation in [11, Conjecture 3.2.1] using  $I$ -functions.

**A.2.1  $I$ -functions and analytic continuation** Following [11, Section 4.2], the cohomology-valued Givental  $I$ -function for the GW theory of the cubic hypersurface

$$\{W_3 = x_1^3 + x_2^3 + x_3^3 = 0\} \subset \mathbb{P}^2$$

is given by<sup>6</sup>

$$(A-6) \quad I_{\text{GW}}(q, z) := \sum_{d \geq 0} zq^{H/z+d} \frac{\prod_{k=1}^{3d} (3H + kz)}{\prod_{k=1}^d (H + kz)^3} = I_0^{\text{GW}}(q)z + I_1^{\text{GW}}(q)H,$$

<sup>6</sup>Here the variable  $q$  should not be confused with the variable  $q = e^{2\pi i \tau}$  in modular forms.

where  $H$  is the hyperplane class of  $\mathbb{P}^2$ . The  $I$ -function for the FJRW theory of the pair  $(W_3, \mu_3)$  is given by

$$(A-7) \quad I_{\text{FJRW}}(t, z) := z \sum_{k=1}^2 \frac{1}{\Gamma(k)} \sum_{\ell \geq 0} \frac{\left(\left(\frac{k}{3}\right)\ell\right)^3 t^{k+3\ell}}{\left(k\right)_3 \ell z^{k-1}} \phi_{k-1} = I_0^{\text{FJRW}}(t)z\mathbf{1} + I_1^{\text{FJRW}}(t)\phi,$$

where  $\phi_0 = \mathbf{1}$  and  $\phi_1 = \phi$  are nontrivial degree-zero and degree-two elements in the state space, respectively. The genus-zero LG/CY correspondence [11] relates these two  $I$ -functions by analytic continuation via  $q = t^{-3}$ . To be more explicit, one has the analytic continuation

$$(A-8) \quad \begin{pmatrix} \frac{1}{3} I_1^{\text{FJRW}}(t) \\ \frac{1}{3} I_0^{\text{FJRW}}(t) \end{pmatrix} = \begin{pmatrix} \frac{(-1)}{\Gamma^3\left(\frac{2}{3}\right)} \frac{2\pi\sqrt{-1}\zeta_3}{1-\zeta_3} & -\frac{(-1)}{\Gamma^3\left(\frac{2}{3}\right)} \frac{(2\pi\sqrt{-1})^2\zeta_3}{(1-\zeta_3)^2} \\ -\frac{(-1)^2}{\Gamma^3\left(\frac{1}{3}\right)} \frac{2\pi\sqrt{-1}\zeta_3^2}{1-\zeta_3^2} & \frac{(-1)^2}{\Gamma^3\left(\frac{1}{3}\right)} \frac{(2\pi\sqrt{-1})^2\zeta_3^2}{(1-\zeta_3^2)^2} \end{pmatrix} \begin{pmatrix} I_1^{\text{GW}}(t(q)) \\ I_0^{\text{GW}}(t(q)) \end{pmatrix},$$

where the normalization factor  $\frac{1}{3}$  on the basis  $\{I_0^{\text{FJRW}}, I_1^{\text{FJRW}}\}$  is introduced so that the connection matrix lies in  $\text{SL}_2(\mathbb{C})$ . In particular, define

$$(A-9) \quad t_{\text{GW}} := \frac{I_1^{\text{GW}}(q)}{I_0^{\text{GW}}(q)} \quad \text{and} \quad t_{\text{FJRW}} := \frac{I_1^{\text{FJRW}}(t)}{I_0^{\text{FJRW}}(t)}.$$

Then one has

$$(A-10) \quad t_{\text{FJRW}} = -e^{\pi i/3} \frac{\Gamma\left(\frac{1}{3}\right)^3}{\Gamma\left(-\frac{1}{3}\right)\Gamma\left(\frac{2}{3}\right)^2} \frac{t_{\text{GW}} - 2\pi i \tau_*}{t_{\text{GW}} - 2\pi i \bar{\tau}_*}.$$

**A.2.2 Cayley transformation** Following the computations in [50] as in Section A.1, we can relate the above  $I$ -functions to modular forms. In particular, we see that

$$(A-11) \quad t_{\text{GW}} := \frac{I_1^{\text{GW}}(q)}{I_0^{\text{GW}}(q)} = 2\pi i \tau, \quad t_{\text{FJRW}} := \frac{I_1^{\text{FJRW}}(t)}{I_0^{\text{FJRW}}(t)} = e^{2\pi i/3} \left(-\frac{\sqrt{3}}{i}\right) \frac{\Gamma\left(\frac{1}{3}\right)^2}{\Gamma\left(-\frac{1}{3}\right)} s.$$

Here  $s$  is the coordinate given in (4-4), again with  $\tau_* = 1/(1 - \zeta_3)$  as given in (4-6) and  $c$  as in (4-7). Analytical continuations on the  $I$ -functions, induced by (A-10), coincide with Cayley transformations on them induced by (4-4), by construction [50].

Through the connection to modular forms, LG/CY correspondence on  $I$ -functions can be restated as follows. Let  $\mathcal{M} = \Gamma(3)\backslash\mathbb{H}^*$  be the modular curve as the global

moduli space, where  $\mathbb{H}^* = \mathbb{H} \cup \mathbb{P}^1(\mathbb{Q})$ . Denote its canonical bundle by  $K_{\mathcal{M}}$ . Then  $I^{\text{GW}}$  and  $I^{\text{FJRW}}$  correspond to descriptions of the same holomorphic section of the line bundle that is isomorphic to  $K_{\mathcal{M}}^{\otimes 1/2}$ , but on different patches of the moduli space. Their coordinate expressions  $I_0^{\text{GW}}$  and  $I_0^{\text{FJRW}}$ , with respect to the trivializations  $(d\tau)^{1/2}$  and  $(ds)^{1/2}$ , respectively, are modular forms related by Cayley transformation.

**A.2.3 Stationary correlation functions** At higher genera, consider the stationary correlation function

$$\langle\langle \alpha_1 \psi_1^{\ell_1}, \dots, \alpha_n \psi_n^{\ell_n} \rangle\rangle_{g,n}^{\clubsuit},$$

with  $\alpha_i = \omega$  when  $\clubsuit = \mathcal{E}_3$  and  $\alpha_i = \phi$  when  $\clubsuit = W_3$ . By applying the  $g$ -reduction technique in Lemma 7 inductively, we see that under the map (A-11) this correlation function on the GW side is the Fourier expansion of a quasimodular form of weight  $2g - 2 + 2n$  near the cusp, and on the FJRW side is the Taylor expansion (in terms of the parameter  $s$ ) of the same quasimodular form near the point  $\tau_*$ .

According to standard facts in the theory of modular forms (see eg [53; 57]) on the transition between quasimodular forms and almost-holomorphic modular forms, we see that on the level of GW correlation functions the modular completion is induced by the transformation mapping of the frame of  $H^{\text{even}}(\mathcal{E}_3, \mathbb{C})$  from  $\{\mathbf{1} + 2\pi i \tau H, 2\pi i H\}$  to  $\{\mathbf{1} + 2\pi i \tau H, (1/(\bar{\tau} - \tau))(\mathbf{1} - 2\pi i \bar{\tau} H)\}$ . This transformation also induces the modular completion on the FJRW correlation functions by composing with the aforementioned transformation that relates  $I^{\text{GW}}$  with  $I^{\text{FJRW}}$ .

Then we have a succinct way to reformulate our higher-genus LG/CY correspondence result on  $\langle\langle \alpha_1 \psi_1^{\ell_1}, \dots, \alpha_n \psi_n^{\ell_n} \rangle\rangle_{g,n}^{\clubsuit}$ . Denote its modular completion by

$$\langle\langle \alpha_1 \psi_1^{\ell_1}, \dots, \alpha_n \psi_n^{\ell_n} \rangle\rangle_{g,n}^{\clubsuit, \hat{\phantom{\clubsuit}}}$$

Let  $I_0^{\clubsuit} = I_0^{\text{GW}}$  and  $d\tau^{\clubsuit} = d\tau$  for  $\clubsuit = \mathcal{E}_3$ , and  $I_0^{\clubsuit} = I_0^{\text{FJRW}}$  and  $d\tau^{\clubsuit} = ds$  for  $\clubsuit = W_3$ . Then the quantity

$$(I_0^{\clubsuit})^{2-2g} \langle\langle \alpha_1 \psi_1^{\ell_1}, \dots, \alpha_n \psi_n^{\ell_n} \rangle\rangle_{g,n}^{\clubsuit, \hat{\phantom{\clubsuit}}} (d\tau^{\clubsuit})^{\otimes n}$$

is a global (smooth with holomorphic pole) section of the holomorphic line bundle  $K_{\mathcal{M}}^{\otimes n}$  on the modular curve  $\mathcal{M} = \Gamma(3) \backslash \mathbb{H}^*$ .

## References

- [1] **A Basalaev, N Priddis**, *Givental-type reconstruction at a nonsemisimple point*, Michigan Math. J. 67 (2018) 333–369 MR Zbl



- [2] **P Belorousski, R Pandharipande**, *A descendent relation in genus 2*, Ann. Scuola Norm. Sup. Pisa Cl. Sci. 29 (2000) 171–191 MR Zbl
- [3] **S Bloch, A Okounkov**, *The character of the infinite wedge representation*, Adv. Math. 149 (2000) 1–60 MR Zbl
- [4] **H-L Chang, Y-H Kiem, J Li**, *Algebraic virtual cycles for quantum singularity theories*, Comm. Anal. Geom. 29 (2021) 1749–1774 MR Zbl
- [5] **H-L Chang, J Li**, *An algebraic proof of the hyperplane property of the genus one GW-invariants of quintics*, J. Differential Geom. 100 (2015) 251–299 MR Zbl
- [6] **H-L Chang, J Li, W-P Li**, *Witten’s top Chern class via cosection localization*, Invent. Math. 200 (2015) 1015–1063 MR Zbl
- [7] **H-L Chang, J Li, W-P Li, C-C M Liu**, *Mixed-spin- $P$  fields of Fermat polynomials*, Camb. J. Math. 7 (2019) 319–364 MR Zbl
- [8] **H-L Chang, J Li, W-P Li, C-C M Liu**, *An effective theory of GW and FJRW invariants of quintic Calabi–Yau manifolds*, J. Differential Geom. 120 (2022) 251–306 MR Zbl
- [9] **A Chiodo**, *Towards an enumerative geometry of the moduli space of twisted curves and  $r$ th roots*, Compos. Math. 144 (2008) 1461–1496 MR Zbl
- [10] **A Chiodo, H Iritani, Y Ruan**, *Landau–Ginzburg/Calabi–Yau correspondence, global mirror symmetry and Orlov equivalence*, Publ. Math. Inst. Hautes Études Sci. 119 (2014) 127–216 MR Zbl
- [11] **A Chiodo, Y Ruan**, *Landau–Ginzburg/Calabi–Yau correspondence for quintic threefolds via symplectic transformations*, Invent. Math. 182 (2010) 117–165 MR Zbl
- [12] **A Chiodo, Y Ruan**, *A global mirror symmetry framework for the Landau–Ginzburg/Calabi–Yau correspondence*, Ann. Inst. Fourier (Grenoble) 61 (2011) 2803–2864 MR Zbl
- [13] **A Chiodo, Y Ruan**, *LG/CY correspondence: the state space isomorphism*, Adv. Math. 227 (2011) 2157–2188 MR Zbl
- [14] **E Clader**, *Landau–Ginzburg/Calabi–Yau correspondence for the complete intersections  $X_{3,3}$  and  $X_{2,2,2,2}$* , Adv. Math. 307 (2017) 1–52 MR Zbl
- [15] **B Dubrovin, Y Zhang**, *Frobenius manifolds and Virasoro constraints*, Selecta Math. 5 (1999) 423–466 MR Zbl
- [16] **T Eguchi, K Hori, C-S Xiong**, *Quantum cohomology and Virasoro algebra*, Phys. Lett. B 402 (1997) 71–80 MR Zbl
- [17] **C Faber, R Pandharipande**, *Relative maps and tautological classes*, J. Eur. Math. Soc. 7 (2005) 13–49 MR Zbl
- [18] **C Faber, S Shadrin, D Zvonkine**, *Tautological relations and the  $r$ -spin Witten conjecture*, Ann. Sci. Éc. Norm. Supér. 43 (2010) 621–658 MR Zbl

- [19] **H Fan, T J Jarvis, Y Ruan**, *The Witten equation and its virtual fundamental cycle*, preprint (2007) arXiv 0712.4025
- [20] **H Fan, T Jarvis, Y Ruan**, *The Witten equation, mirror symmetry, and quantum singularity theory*, *Ann. of Math.* 178 (2013) 1–106 MR Zbl
- [21] **A Francis**, *Computational techniques in FJRW theory with applications to Landau–Ginzburg mirror symmetry*, *Adv. Theor. Math. Phys.* 19 (2015) 1339–1383 MR Zbl
- [22] **A B Givental**, *Gromov–Witten invariants and quantization of quadratic Hamiltonians*, *Mosc. Math. J.* 1 (2001) 551–568 MR Zbl
- [23] **A B Givental**, *Semisimple Frobenius structures at higher genus*, *Int. Math. Res. Not.* (2001) 1265–1286 MR Zbl
- [24] **B R Greene, C Vafa, N P Warner**, *Calabi–Yau manifolds and renormalization group flows*, *Nuclear Phys. B* 324 (1989) 371–390 MR Zbl
- [25] **S Guo, D Ross**, *The genus-one global mirror theorem for the quintic 3–fold*, *Compos. Math.* 155 (2019) 995–1024 MR Zbl
- [26] **S Guo, D Ross**, *Genus-one mirror symmetry in the Landau–Ginzburg model*, *Algebr. Geom.* 6 (2019) 260–301 MR Zbl
- [27] **W He, Y Shen**, *Virasoro constraints in quantum singularity theories*, preprint (2021) arXiv 2103.00313
- [28] **E-N Ionel**, *Topological recursive relations in  $H^{2g}(M_{g,n})$* , *Invent. Math.* 148 (2002) 627–658 MR Zbl
- [29] **H Iritani, T Milanov, Y Ruan, Y Shen**, *Gromov–Witten theory of quotients of Fermat Calabi–Yau varieties*, *Mem. Amer. Math. Soc.* 1310, Amer. Math. Soc., Providence, RI (2021) MR Zbl
- [30] **M Kaneko, D Zagier**, *A generalized Jacobi theta function and quasimodular forms*, from “The moduli space of curves” (R Dijkgraaf, C Faber, G van der Geer, editors), *Progr. Math.* 129, Birkhäuser, Boston, MA (1995) 165–172 MR Zbl
- [31] **Y-H Kiem, J Li**, *Quantum singularity theory via cosection localization*, *J. Reine Angew. Math.* 766 (2020) 73–107 MR Zbl
- [32] **M Kontsevich, Y Manin**, *Gromov–Witten classes, quantum cohomology, and enumerative geometry*, *Comm. Math. Phys.* 164 (1994) 525–562 MR Zbl
- [33] **M Kontsevich, Y Manin**, *Relations between the correlators of the topological sigma-model coupled to gravity*, *Comm. Math. Phys.* 196 (1998) 385–398 MR Zbl
- [34] **M Krawitz, Y Shen**, *Landau–Ginzburg/Calabi–Yau correspondence of all genera for elliptic orbifold  $\mathbb{P}^1$* , preprint (2011) arXiv 1106.6270
- [35] **Y-P Lee**, *Notes on axiomatic Gromov–Witten theory and applications*, from “Algebraic geometry” (D Abramovich, A Bertram, L Katzarkov, R Pandharipande, M Thaddeus, editors), *Proc. Sympos. Pure Math.* 80, Amer. Math. Soc., Providence, RI (2009) 309–323 MR Zbl

- [36] **Y-P Lee, N Priddis, M Shoemaker**, *A proof of the Landau–Ginzburg/Calabi–Yau correspondence via the crepant transformation conjecture*, Ann. Sci. Éc. Norm. Supér. 49 (2016) 1403–1443 MR Zbl
- [37] **Y-P Lee, M Shoemaker**, *A mirror theorem for the mirror quintic*, Geom. Topol. 18 (2014) 1437–1483 MR Zbl
- [38] **J Li, W-P Li, Y Shen, J Zhou**, *A genus-one FJRW invariant via two methods*, Math. Z. 302 (2022) 1927–1955 MR Zbl
- [39] **E J Martinec**, *Criticality, catastrophes, and compactifications*, from “Physics and mathematics of strings” (L Brink, D Friedan, A M Polyakov, editors), World Sci., Teaneck, NJ (1990) 389–433 MR Zbl
- [40] **T Milanov, Y Ruan**, *Gromov–Witten theory of elliptic orbifold  $\mathbb{P}^1$  and quasi-modular forms*, preprint (2011) arXiv 1106.2321
- [41] **T Milanov, Y Shen**, *Global mirror symmetry for invertible simple elliptic singularities*, Ann. Inst. Fourier (Grenoble) 66 (2016) 271–330 MR Zbl
- [42] **G Oberdieck, A Pixton**, *Holomorphic anomaly equations and the Igusa cusp form conjecture*, Invent. Math. 213 (2018) 507–587 MR Zbl
- [43] **A Okounkov, R Pandharipande**, *Gromov–Witten theory, Hurwitz theory, and completed cycles*, Ann. of Math. 163 (2006) 517–560 MR Zbl
- [44] **A Okounkov, R Pandharipande**, *Virasoro constraints for target curves*, Invent. Math. 163 (2006) 47–108 MR Zbl
- [45] **A Pixton**, *The Gromov–Witten theory of an elliptic curve and quasimodular forms*, senior thesis, Princeton University (2008)
- [46] **A Polishchuk, A Vaintrob**, *Matrix factorizations and cohomological field theories*, J. Reine Angew. Math. 714 (2016) 1–122 MR Zbl
- [47] **A Popa**, *The genus one Gromov–Witten invariants of Calabi–Yau complete intersections*, Trans. Amer. Math. Soc. 365 (2013) 1149–1181 MR Zbl
- [48] **Y Ruan**, *The Witten equation and the geometry of the Landau–Ginzburg model*, from “String–Math 2011” (J Block, J Distler, R Donagi, E Sharpe, editors), Proc. Sympos. Pure Math. 85, Amer. Math. Soc., Providence, RI (2012) 209–240 MR
- [49] **Y Shen, J Zhou**, *Ramanujan identities and quasi-modularity in Gromov–Witten theory*, Commun. Number Theory Phys. 11 (2017) 405–452 MR Zbl
- [50] **Y Shen, J Zhou**, *LG/CY correspondence for elliptic orbifold curves via modularity*, J. Differential Geom. 109 (2018) 291–336 MR Zbl
- [51] **J H Silverman**, *The arithmetic of elliptic curves*, 2nd edition, Graduate Texts in Math. 106, Springer (2009) MR Zbl
- [52] **C Teleman**, *The structure of 2D semi-simple field theories*, Invent. Math. 188 (2012) 525–588 MR Zbl

- [53] **E Urban**, *Nearly overconvergent modular forms*, from “Iwasawa theory 2012” (T Bouganis, O Venjakob, editors), *Contrib. Math. Comput. Sci.* 7, Springer (2014) 401–441 MR Zbl
- [54] **C Vafa, N Warner**, *Catastrophes and the classification of conformal theories*, *Phys. Lett. B* 218 (1989) 51–58 MR
- [55] **K Weierstrass**, *Zur Theorie der elliptischen Funktionen*, *Sitzungsberichte der Königlich Preussischen Akademie der Wissenschaften zu Berlin* (1882) 443–451 Zbl Reprinted in “*Mathematische Werke*”, vol. 2, Teubner, Berlin (1894) 245–255
- [56] **E Witten**, *Phases of  $N = 2$  theories in two dimensions*, *Nuclear Phys. B* 403 (1993) 159–222 MR Zbl
- [57] **D Zagier**, *Elliptic modular forms and their applications*, from “The 1-2-3 of modular forms” (K Ranestad, editor), Springer (2008) 1–103 MR Zbl
- [58] **A Zinger**, *The reduced genus 1 Gromov–Witten invariants of Calabi–Yau hypersurfaces*, *J. Amer. Math. Soc.* 22 (2009) 691–737 MR Zbl

*Shanghai Center for Mathematical Sciences, Fudan University  
Shanghai, China*

*Department of Mathematics, University of Oregon  
Eugene, OR, United States*

*Yau Mathematical Sciences Center, Tsinghua University  
Beijing, China*

lijun2210@fudan.edu.cn, yfshen@uoregon.edu,  
jzhou2018@mail.tsinghua.edu.cn

Proposed: Jim Bryan  
Seconded: Paul Seidel, Mark Gross

Received: 29 September 2020  
Revised: 9 November 2021

# Compact moduli of elliptic K3 surfaces

KENNETH ASCHER

DORI BEJLERI

We construct various modular compactifications of the space of elliptic K3 surfaces using tools from the minimal model program, and explicitly describe the surfaces parametrized by their boundaries. The coarse spaces of our constructed compactifications admit morphisms to the Satake–Baily–Borel compactification and the GIT compactification of Miranda.

14J10, 14J27, 14J28; 14D20

1. Introduction	1891
2. Elliptic K3 surfaces and their moduli	1897
3. Moduli of $\mathcal{A}$ -broken elliptic surfaces and wall-crossing	1901
4. Moduli of weighted stable elliptic K3 surfaces	1909
5. Wall crossings inside $\overline{\mathcal{W}}_\sigma(a)$ for $a > \frac{1}{12}$	1913
6. Surfaces in $\overline{\mathcal{W}}_\sigma(\epsilon)$ , the 24-marked space at $a = \epsilon$	1925
7. Explicit description of the boundary of $\overline{\mathcal{W}}_\sigma(\epsilon)$	1934
8. Spaces with one marked fiber	1938
References	1944

## 1 Introduction

Ever since the compactification of the moduli space of smooth curves by Deligne and Mumford was accomplished, the search for analogous compactifications in higher dimensions became an actively studied problem in algebraic geometry. While moduli in higher dimensions is highly intricate, the pioneering work of Kollár and Shepherd-Barron [31] and Alexeev [3] (see also Hacon, McKernan and Xu [19], Hacon and

Xu [20] Kollár [28] and Kovács and Patakfalvi [32]) has established much of the underlying framework for modular compactifications in the (log) general type case via *KSBA stable pairs*, where semi-log canonical singularities serve as the generalization of nodal curves; see the survey by Kollár [27].

One of the most sought-after compactifications is for the space of K3 surfaces. K3 surfaces do not immediately fit into the above framework as they are not of general type, but rather Calabi–Yau varieties. On the other hand, like for abelian varieties, since the space of (polarized) K3 surfaces is a locally symmetric variety it has several natural compactifications, eg the Satake–Baily–Borel (SBB), toroidal, and semitoric compactifications of Looijenga. Unlike the KSBA approach, these compactifications do not necessarily carry a universal family or modular meaning over the boundary.

As such, one of the central questions in moduli theory is to give the aforementioned naturally arising compactifications a stronger geometric meaning by connecting them with a KSBA compactification. With this in mind, our goal is to construct modular compactifications for elliptic K3 surfaces — compactifications where the degenerate objects are K3 surfaces with controlled singularities — and understand how they compare to the Satake–Baily–Borel compactification.

By the Torelli theorem, the moduli space of polarized K3 surfaces is a 19–dimensional locally symmetric variety. Similarly, it is well known that the moduli space of elliptic K3 surfaces with a section, which we denote by  $\mathcal{W}$  with coarse space  $W$ , is an 18–dimensional locally symmetric variety, corresponding to  $U$ –polarized K3 surfaces; see Dolgachev [14] and Nikulin [38]. Recall that a generic elliptic K3 surface  $f: X \rightarrow \mathbb{P}^1$  with section  $S$  has 24  $I_1$  singular fibers. Let  $F_{\mathcal{A}} = \sum a_i F_i$  denote the sum of these 24 fibers weighted by  $a_i \in \mathbb{Q} \cap [0, 1]^{24}$ . We consider the closure of the locus of pairs  $(f: X \rightarrow C, S + F_{\mathcal{A}})$  inside the KSBA moduli space. For the moment we assume all  $a_i = a$ , so that we can quotient by  $S_{24}$ . Denote the closure of the resulting locus by  $\overline{W}_{\sigma}(a)$ , and let  $0 < \epsilon \ll 1$ .

**Theorem 1.1** (Theorems 6.13, 6.15 and 6.14, and Figure 1) *The proper Deligne–Mumford stacks  $\overline{W}_{\sigma}(a)$  for  $a \in \mathbb{Q} \cap [0, 1]$  give modular compactifications of  $\mathcal{W}$ . There is an explicit classification of the broken elliptic K3 surfaces parametrized by  $\overline{W}_{\sigma}(\epsilon)$ , and an explicit morphism from the coarse space  $\overline{W}_{\sigma}(\epsilon)$  to  $\overline{W}^*$ , the SBB compactification of  $W$ . Furthermore, the surfaces parametrized by  $\overline{W}_{\sigma}(\epsilon)$  satisfy  $H^1(X, \mathcal{O}_X) = 0$  and  $\omega_X \cong \mathcal{O}_X$ .*

Theorem 1.1 shows that the boundary of  $\overline{\mathcal{W}}_\sigma(\epsilon)$  parametrizes K3 surfaces with slc singularities. Although  $\overline{\mathcal{W}}_\sigma(\epsilon)$  compactifies a moduli space of pairs, it gives a natural compactification of the space of elliptic K3s as the singular fibers are an intrinsic choice of divisor. Moreover, without choosing a divisor, the moduli space is a nonseparated Artin stack. In Section 7, we present an alternative explicit description of the surfaces parametrized on the boundary of the moduli space more akin to Kulikov models. In particular, we show that we can decompose the boundary of  $\overline{\mathcal{W}}_\sigma(a)$  into combinatorially described parameter spaces.

As mentioned above, viewing the moduli space of elliptic K3 surfaces as a locally symmetric variety, one naturally obtains the SBB compactification  $\overline{\mathcal{W}}^*$ . While a priori the SBB compactification does not have a modular meaning, it turns out that in the case of elliptic K3 surfaces, this compactification can be identified with the GIT compactification of Weierstrass models of Miranda  $\overline{\mathcal{W}}^G$  (see Section 2.6 and Odaka and Oshima [39, Theorem 7.9]), which provides some geometric meaning. In particular, in the theorem above as well as the remainder of this section, all of our spaces admit morphisms to  $\overline{\mathcal{W}}^G$ .

One benefit of the SBB compactification is that all of the parametrized surfaces are irreducible. The next theorem discusses a modular compactification coming from the KSBA approach, where the boundary parametrizes irreducible surfaces. Indeed, consider pairs  $(f: X \rightarrow \mathbb{P}^1, S + \epsilon F)$  for  $0 < \epsilon \ll 1$ , ie only one singular fiber carries a nonzero weight, and this weight is very small. We denote the closure of this locus by  $\overline{\mathcal{K}}_\epsilon$ .

**Theorem 1.2** (Theorems 8.1 and 8.2, and Figure 1) *The compact moduli space  $\overline{\mathcal{K}}_\epsilon$  parametrizes irreducible semi-log canonical Weierstrass elliptic K3 surfaces satisfying  $H^1(X, \mathcal{O}_X) = 0$  and  $\omega_X \cong \mathcal{O}_X$ . Moreover, there is an explicit generically finite morphism from the coarse space  $\overline{\mathcal{K}}_\epsilon$  to  $\overline{\mathcal{W}}^*$ .*

In light of the above theorem, it is natural to ask how the compactifications  $\overline{\mathcal{W}}_\sigma(\epsilon)$  and  $\overline{\mathcal{K}}_\epsilon$  are related. In previous work (see Ascher and Bejleri [8]) we showed the existence of wall-crossing morphisms on moduli spaces of elliptic surfaces. In particular, our previous work implies that (up to a 24-to-1 base change corresponding to choosing a singular fiber) the universal families of  $\overline{\mathcal{W}}_\sigma(\epsilon)$  and  $\overline{\mathcal{K}}_\epsilon$  are related by an explicit series of flips and divisorial contractions as the weights of 23 of the marked fibers are reduced from  $\epsilon$  to 0. This aspect is crucial to our work (see eg Section 8.1) — these explicit morphisms allow us to understand how our compactifications are related to each other, and how they compare to others lacking a modular meaning.

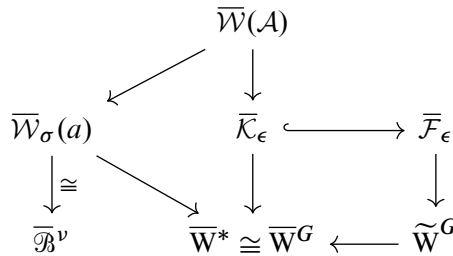

Figure 1: This diagram shows the various compactifications we introduce as well as how they are related; see also Remark 4.10.

Finally, we introduce one more KSBA compactification. While in  $\bar{\mathcal{K}}_\epsilon$  we mark one singular fiber with weight  $\epsilon$ , it is natural to ask what happens if we mark *any* fiber, not necessarily singular, with weight  $\epsilon$ . We denote this compactification by  $\bar{\mathcal{F}}_\epsilon$ . See Figure 1 for the relations between the spaces we introduce, which are:

- $\bar{\mathcal{B}}^\nu$  The normalization of Brunyate’s compactification with small weights on both section and singular fibers; see Section 1.1.
- $\bar{\mathcal{W}}(\mathcal{A})$  The KSBA compactification with  $\mathcal{A}$ -weighted singular fibers.
- $\bar{\mathcal{W}}_\sigma(a)$  The quotient by  $S_{24}$  when  $\mathcal{A} = (a, \dots, a)$ .
- $\bar{\mathcal{K}}_\epsilon$  The KSBA compactification with a single  $\epsilon$ -marked singular fiber (where  $\epsilon \ll 1$ ).
- $\bar{\mathcal{F}}_\epsilon$  The KSBA compactification with *any fiber* marked by  $\epsilon$  (where  $\epsilon \ll 1$ ).
- $\bar{\mathcal{W}}^*$  The SBB compactification of the period domain moduli space  $W$ .
- $\bar{\mathcal{W}}^G$  Miranda’s GIT compactification of Weierstrass models; see Section 2.6.
- $\tilde{\mathcal{W}}^G$  The GIT compactification of Weierstrass models with a chosen fiber; see the discussion after Theorem 1.3.

**Theorem 1.3** (Theorem 8.8 and Figure 1) *There exists a smooth proper Deligne–Mumford stack  $\bar{\mathcal{F}}_\epsilon$  parametrizing semi-log canonical elliptic K3 surfaces with a single marked fiber. Its coarse space is isomorphic to an explicit GIT quotient  $\tilde{\mathcal{W}}^G$  of Weierstrass K3 surfaces and a chosen fiber. Furthermore, the surfaces parametrized by  $\bar{\mathcal{F}}_\epsilon$  satisfy  $H^1(X, \mathcal{O}_X) = 0$  and  $\omega_X \cong \mathcal{O}_X$ .*

On the interior,  $\bar{\mathcal{F}}_\epsilon$  is a  $\mathbb{P}^1$  bundle over  $W$ . In this sense  $\bar{\mathcal{F}}_\epsilon$  is similar in spirit to the KSBA compactification of Laza of degree-two K3 surfaces [34]. The GIT problem



of Miranda can be modified to parametrize Weierstrass fibrations with a chosen fiber (see Section 8.3), denoted above by  $\widetilde{W}^G$ . It turns out that  $\widetilde{W}^G$  is precisely the coarse moduli space of  $\overline{\mathcal{F}}_\epsilon$ ; in particular, the morphism  $\overline{\mathcal{F}}_\epsilon \rightarrow \widetilde{W}^G$  realizes  $\overline{\mathcal{F}}_\epsilon$  as a smooth Deligne–Mumford stack.

Our approach combines explicit use of the theory of twisted stable maps (see eg Ascher and Bejleri [7]) with the minimal model program (MMP). The various compactifications are then related by an explicit series of wall-crossing morphisms. In particular, we wish to emphasize that the power of our approach lies in understanding the compactifications for various coefficients and how they are related via wall crossing morphisms. Often the spaces with very small coefficients are the smallest compactifications which are still modular, but having access to the spaces for all coefficients is helpful in understanding the geometry of compactifications obtained via different methods.

## 1.1 Previous results

Using Kulikov models, Brunyate’s thesis [12] constructs a stable pairs compactification of the space of elliptic K3 surfaces  $\overline{\mathcal{B}}$  which parametrizes pairs  $(X, \epsilon S + \delta F)$ , where  $\epsilon$  and  $\delta$  are both small. In particular, Brunyate gives a classification of the surfaces appearing on the boundary, and conjectures that the normalization of  $\overline{\mathcal{B}}$  is a toroidal compactification. Recently Alexeev, Brunyate and Engel [4] confirmed Brunyate’s conjecture, and showed that this space is isomorphic to a particular toroidal compactification using the theory of integral affine geometry and continuing the program started by Alexeev, Engel and Thompson [5].

One difference between our approach and the work of Brunyate is in our descriptions of the compactifications at various weights and choice of markings. Instead of using Kulikov models, we describe the steps of MMP and the induced wall-crossing morphisms that relate the stable limits of elliptic K3 surfaces for different weights to highlight the underlying geometry of the various compactifications. Brunyate’s space  $\overline{\mathcal{B}}$  admits a morphism  $\overline{\mathcal{W}}_\sigma(\epsilon) \rightarrow \overline{\mathcal{B}}$  which identifies  $\overline{\mathcal{W}}_\sigma(\epsilon)$  with the normalization of  $\overline{\mathcal{B}}$ ; see Proposition 4.4 and Remark 4.7. In particular, the boundary components of  $\overline{\mathcal{B}}$  and  $\overline{\mathcal{W}}_\sigma(\epsilon)$  are in bijection (see Remark 4.5) and the moduli spaces parametrize essentially the same surfaces. Indeed there is a sequence of flips relating the universal family of  $\overline{\mathcal{B}}$  and the universal family over  $\overline{\mathcal{W}}_\sigma(\epsilon)$  which induces this morphism.

Finally, we note that in a slightly different direction, Inchiostro constructs a KSBA compactification of the space of Weierstrass fibrations (of not necessarily K3 surfaces) with both section and fibers marked by  $0 < \epsilon, \delta \ll 1$  [25],

## 1.2 Other lattice polarizations

It is natural to consider fibrations with specified singular fibers. In this case, one obtains a moduli space which is a locally symmetric variety, corresponding to a  $M$ -lattice polarization, encoding the singular fiber type. Our methods work in that case as well. Here we quickly discuss an example of this point of view.

**Example 1.4** Consider the lattice  $M = U \oplus D_4^{\oplus 4}$ . Then  $M$ -polarized K3 surfaces correspond to  $4I_0^*$  isotrivial elliptic K3 surfaces. Equivalently, these are Kummer K3 surfaces obtained from abelian surfaces of the form  $E \times E'$  with the elliptic fibration induced by the projection  $E \times E' \rightarrow E$ . Marking the four minimal Weierstrass cusps by a single weight  $a$  gives us a moduli space whose coarse space is two copies of the  $j$ -line, one parametrizing the  $j$ -invariant of the fibration, and the other the  $j$ -invariant of the configuration of singular fibers. The stable pairs compactification has coarse space given by  $\mathbb{P}^1 \times \mathbb{P}^1 = \overline{M}_{0,4} \times \overline{M}_{0,4}$ . The universal family consists of  $4N_1$  isotrivial  $j$ -invariant  $\infty$  fibrations over the locus  $\{\infty\} \times \mathbb{P}^1$ , a union  $X \cup_{I_0} X$  of two copies of the  $2I_0^*$  rational elliptic surface glued along a smooth fiber over the locus  $\mathbb{P}^1 \times \{\infty\}$ , and a union  $X \cup_{N_0} X$  of two copies of the  $2N_1$  isotrivial  $j$ -invariant  $\infty$  fibration glued along an  $N_0$  fiber over the point  $(\infty, \infty)$ .

### Structure of the paper

In Section 2 we discuss the background on elliptic K3 surfaces and their moduli (as a period domain, the Satake–Baily–Borel compactification, and a geometric invariant theory compactification). In Section 3 we review the results from our previous works [6; 7; 8; 9] on KSBA compactifications of moduli spaces of elliptic fibrations and the connection with twisted stable maps. In Section 4 we restrict to the case of elliptic K3 surfaces and collect the definitions of and preliminary observations on the compactifications we consider, including a discussion on isotrivial  $j$ -invariant  $\infty$  fibrations of K3 type.

The main body of the paper begins with Section 5, where we discuss the wall-crossings that occur for the compactification  $\overline{\mathcal{W}}_\sigma(a)$  as the coefficient  $a$  is lowered from 1 down to  $\frac{1}{12} + \epsilon$  for  $0 < \epsilon \ll 1$ . In Section 6 we continue the wall-crossing analysis as  $a$  is decreased down to  $0 < \epsilon \ll 1$ , and we prove Theorem 1.1, which describes the surfaces appearing on the boundary of the moduli space  $\overline{\mathcal{W}}_\sigma(\epsilon)$ . In Section 7 we use Theorem 1.1 and twisted stable maps (see Section 3.2) to explicitly describe the

boundary components of  $\overline{\mathcal{W}}_\sigma(\epsilon)$ . Finally, in Section 8 we describe the moduli spaces with one marked fiber ( $\overline{\mathcal{K}}_\epsilon$  and  $\overline{\mathcal{F}}_\epsilon$ ) and prove Theorems 1.2 and 1.3; the latter theorem is proven by introducing a modified version of Miranda's GIT compactification; see Section 8.3.

## Acknowledgments

We thank Valery Alexeev, Izzet Coskun, Kristin DeVleming, Giovanni Inchiostro, János Kollár, Radu Laza, Yuchen Liu, Siddharth Mathur, Yuji Odaka, and David Yang. We thank Adrian Brunyate for pointing out a gap in a previous version. We thank the referees for their very helpful comments and suggestions. Both authors were supported by NSF postdoctoral fellowships. Part of this paper was written while Ascher was in residence at the Mathematical Sciences Research Institute in Berkeley, CA, during Spring 2019, supported by the National Science Foundation under grant no. 1440140. Ascher was partially supported by NSF grant DMS-2140781 (formerly DMS-2001408).

## 2 Elliptic K3 surfaces and their moduli

### 2.1 Elliptic surfaces

We begin with the basic definitions surrounding elliptic surfaces following [8]; see also [37].

**Definition 2.1** An irreducible *elliptic surface with section*  $(f: X \rightarrow C, S)$  is an irreducible surface  $X$  together with a surjective proper flat morphism  $f: X \rightarrow C$  to a smooth curve  $C$  and a section  $S$  such that

- (i) the generic fiber of  $f$  is a stable elliptic curve, and
- (ii) the generic point of the section is contained in the smooth locus of  $f$ .

We call the pair  $(f: X \rightarrow C, S)$  *standard* if all of  $S$  is contained in the smooth locus of  $f$ .

**Definition 2.2** A *Weierstrass fibration* is an elliptic surface obtained from a standard elliptic surface by contracting all fiber components not meeting the section. We call the output of this process a *Weierstrass model*. If starting with a smooth relatively minimal elliptic surface, we call the result a *minimal Weierstrass model*.

The geometry of an elliptic surface is largely influenced by the *fundamental line bundle*  $\mathcal{L}$ .

**Definition 2.3** The *fundamental line bundle* of a standard elliptic surface is

$$(1) \quad \mathcal{L} := (f_*\mathcal{N}_{S/X})^{-1},$$

where  $\mathcal{N}_{S/X}$  denotes the normal bundle of  $S$  in  $X$ . For an arbitrary elliptic surface we define  $\mathcal{L}$  as the line bundle associated to its minimal semiresolution.<sup>1</sup>

For  $X$  a standard elliptic surface, the line bundle  $\mathcal{L}$  is invariant under taking a semiresolution or Weierstrass model, is independent of choice of section  $S$ , has nonnegative degree, and determines the canonical bundle of  $X$  if  $X$  is either relatively minimal or Weierstrass; see [37, III.1.1].

## 2.2 Singular fibers

If  $(f: X \rightarrow C, S)$  is a smooth relatively minimal elliptic surface, then  $f$  has finitely many singular fibers, which are each unions of rational curves with possibly nonreduced components whose dual graphs are ADE Dynkin diagrams. The singular fibers were classified by Kodaira and Néron (see [11, Section V.7]).

An elliptic surface in Weierstrass form can be described locally by an equation of the form  $y^2 = x^3 + Ax + B$ , where  $A$  and  $B$  are functions of the base curve. Furthermore, the possible singular fiber types can be characterized in terms of vanishing orders of  $A$  and  $B$  by Tate's algorithm; see [43, Table 1]. Moreover, if the smooth relatively minimal model  $(f: X \rightarrow C, S)$  has a singular fiber with a given Dynkin diagram, the minimal Weierstrass model will have an ADE singularity of the same type.

## 2.3 Elliptic K3 surfaces

By the canonical bundle formula and the observation that  $\deg \mathcal{L} = 0$  if and only if the surface is a product, a smooth elliptic surface with section  $(f: X \rightarrow C, S)$  is a K3 surface if and only if  $C \cong \mathbb{P}^1$  and  $\deg(\mathcal{L}) = 2$ ; see [37, III.4.6].

**Definition 2.4** A standard (possibly singular) elliptic surface is of *K3 type* if  $C \cong \mathbb{P}^1$  and  $\deg(\mathcal{L}) = 2$ .

For an elliptic surface of K3 type, the Weierstrass model is given by  $y^2 = x^3 + Ax + B$ , where  $A$  and  $B$  are sections of  $\mathcal{O}(8)$  and  $\mathcal{O}(12)$ , respectively, and the *discriminant*  $\mathcal{D} = 4A^3 + 27B^2$  is a section of  $\mathcal{L}^{\otimes 12} \cong \mathcal{O}(24)$ .

<sup>1</sup>The seminormal version of resolution of singularities; see eg [26, Section 1.13].

**Remark 2.5** The number of singular fibers of a Weierstrass elliptic K3 counted with multiplicity is 24, and a generic elliptic K3 has exactly 24 nodal ( $I_1$ ) singular fibers.

## 2.4 Moduli of lattice polarized K3 surfaces

We now discuss lattice polarized K3 surfaces and their moduli; see [21; 15; 16]. An elliptic K3 with section  $(f: X \rightarrow \mathbb{P}^1, S)$  is characterized by the fact that  $\text{NS}(X)$  contains a lattice  $U$  which is spanned by the classes of the fiber  $f$  and section  $S$ . The moduli of K3 surfaces with specified  $\text{NS}(X)$  were studied by Dolgachev [14]; see also [38]. By the Torelli theorem for polarized K3 surfaces, the moduli space of minimal Weierstrass elliptic K3 surfaces with at worst ADE singularities is an 18–dimensional locally symmetric variety  $W = \Gamma \backslash D$  associated to the lattice  $U_{\text{K3}}^\perp \cong U^2 \oplus E_8^2$ .

## 2.5 The Satake–Baily–Borel compactification

One can use the techniques of Baily and Borel [10] to obtain a compactification  $\overline{W}^*$  by adding some curves and points. We briefly review this compactification following [35, Section 3.1]. The boundary components of  $\overline{W}^*$  are determined by rational maximal parabolic subgroups of the identity component of the orthogonal group  $O(2, 18)$  of the lattice  $U_{\text{K3}}^\perp$ . Every boundary component of  $\overline{W}^*$  has the structure of a locally symmetric variety of lower dimension. We recall the following properties:

- (i) The compactification is canonical.
- (ii) The boundary components have high codimension (as they are points and curves).
- (iii) The compactification is *minimal*: if  $S$  is a smooth variety with  $\overline{S}$  a smooth simple normal crossing compactification, then any locally liftable map  $S \rightarrow W$  extends to a regular map  $\overline{S} \rightarrow \overline{W}^*$ .

**Theorem 2.6** [21, Section 2.3; 42] *The boundary of  $\overline{W}^*$  is a union of 0– and 1–dimensional strata. The 0–dimensional strata correspond to K3s of type III, and the 1–dimensional strata to degenerate K3s of type II. Moreover, the 1–dimensional strata are all rational curves, each parametrizing the  $j$ –invariant of the elliptic double curves appearing in the corresponding type II degenerate K3.*

## 2.6 Geometric invariant theory

Miranda [36] used geometric invariant theory (GIT) to construct a compactification of the moduli space of Weierstrass fibrations, and completed an explicit classification in

the case of rational elliptic surfaces. More recently, Odaka and Oshima [39] explicitly calculated Miranda's compactification for the case of elliptic K3 surfaces. Moreover, they showed that the GIT compactification of Miranda,  $\overline{W}^G$ , is isomorphic to  $\overline{W}^*$ , the SBB compactification. In particular, using this identification, one is able to give a geometric meaning to  $\overline{W}^*$  by relating the boundary of  $\overline{W}^*$  with the GIT polystable orbits in  $\overline{W}^G$ . We review these results now.

Let  $\Gamma_n = \Gamma(\mathbb{P}^1, \mathcal{O}_{\mathbb{P}^1}(n))$ . The surface  $X$  has a *Weierstrass equation*, and as such  $X$  can be realized as a divisor in a  $\mathbb{P}^2$ -bundle over the base curve. For the Weierstrass model of an elliptic K3 surface, we think of  $X$  as being the closed subscheme of  $\mathbb{P}(\mathcal{O}_{\mathbb{P}^1}(4) \oplus \mathcal{O}_{\mathbb{P}^1}(6) \oplus \mathcal{O}_{\mathbb{P}^1})$  defined by the equation  $y^2z = x^3 + Axz^2 + Bz^3$ , where  $A \in \Gamma_8$ ,  $B \in \Gamma_{12}$ , and

- (i)  $4A(q)^3 + 27B(q)^2 = 0$  precisely at the (finitely many) singular fibers  $X_q$ , and
- (ii) for each  $q \in \mathbb{P}^1$  we have  $v_q(A) \leq 3$  or  $v_q(B) \leq 5$ .

We note that any Weierstrass elliptic K3 surface with section and ADE singularities satisfies the above conditions, and conversely, the surface defined as above is a Weierstrass elliptic K3 surface with section and ADE singularities; see [39, Theorem 7.1].

We write  $V_{24} = \Gamma_8 \oplus \Gamma_{12}$  and define the GIT moduli space for Weierstrass elliptic K3 surfaces by  $\overline{W}^G = V_{24}^{\text{ss}} // \text{SL}_2$ . By the above discussion the open locus  $W^G \subset \overline{W}^G$  parametrizes the ADE Weierstrass elliptic K3 surfaces. The following theorem describes the boundary  $\overline{W}^G \setminus W^G$ :

**Theorem 2.7** [39, Proposition 7.4] *The boundary  $\overline{W}^G \setminus W^G$  consists of*

- (i) a 1-dimensional component  $\overline{W}_{\text{slc}}^G$  parametrizing isotrivial  $j$ -invariant  $\infty$  slc surfaces,
- (ii) a 1-dimensional component  $\overline{W}_L^G$  whose open locus  $\overline{W}_{L,o}^G$  parametrizes normal surfaces with two type L type cusps.

Furthermore, the intersection of the two components is the infinity point of both  $\mathbb{P}^1$ s parametrizing the unique  $j$ -invariant  $\infty$  slc surface with two L type cusps. This point is polystable, and the strictly semistable locus is  $\overline{W}_L^G$ , ie  $\overline{W}_{\text{slc}}^G$  is part of the GIT-stable locus of  $\overline{W}^G$ .

It is natural to compare the GIT compactification  $\overline{W}^G$  to the SBB compactification  $\overline{W}^*$ . This is the content of [39, Theorem 7.9], where we define  $\overline{W}_{\text{slc},o}^G := \overline{W}_{\text{slc}}^G \setminus \overline{W}_L^G$ .

**Theorem 2.8** [39, Theorem 7.9] *The period map  $W^G \rightarrow W$  extends to an isomorphism  $\overline{W}^G \cong \overline{W}^*$ , which identifies  $\overline{W}_{\text{slc},o}^G \cup \overline{W}_{L,o}^G$  with the 1–dimensional cusps and identifies  $\overline{W}_{\text{slc}}^G \cap \overline{W}_L^G$  with the 0–dimensional cusp.*

### 3 Moduli of $\mathcal{A}$ –broken elliptic surfaces and wall-crossing

In this section we review and supplement the results from our previous work on compactifications of the moduli spaces of elliptic surfaces via KSBA stable pairs.

**Definition 3.1** A KSBA stable pair  $(X, D)$  is a pair consisting of a variety  $X$  and a Weil divisor  $D$  such that

- (i)  $(X, D)$  has semi-log canonical (slc) singularities, and
- (ii)  $K_X + D$  is an ample  $\mathbb{Q}$ –Cartier divisor.

Stable pairs are the natural higher-dimensional generalization of stable curves, and their moduli space compactifies the moduli space of log canonical models of pairs of log general type.

In [8], we defined KSBA compactifications  $\mathcal{E}_{\mathcal{A}}$  of the moduli space of log canonical (lc) models  $(f : X \rightarrow C, S + F_{\mathcal{A}})$  of  $\mathcal{A}$ –weighted Weierstrass elliptic surface pairs. For each admissible weight vector  $\mathcal{A}$ , we obtained a compactification  $\mathcal{E}_{\mathcal{A}}$ , which is representable by a proper Deligne–Mumford stack of finite type [8, Theorems 1.1 and 1.2]. These spaces parametrize slc pairs  $(f : X \rightarrow C, S + F_{\mathcal{A}})$ , where  $(f : X \rightarrow C, S)$  is an slc elliptic surface with section,  $F_{\mathcal{A}} = \sum a_i F_i$  is a weighted sum of marked fibers with  $\mathcal{A} = (a_1, \dots, a_n)$ , and  $0 < a_i \leq 1$ , and  $(X, S + F_{\mathcal{A}})$  is a stable pair.

Before stating the main result, Theorem 3.6, we must first discuss the different (singular) fiber types that appear in semi-log canonical models of elliptic fibrations as studied in [6].

**Definition 3.2** Let  $(g : Y \rightarrow C, S' + aF')$  be a Weierstrass elliptic surface pair over the spectrum of a DVR and let  $(f : X \rightarrow C, S + F_a)$  be its relative log canonical model. We say that  $X$  has

- (i) a *twisted fiber* if the special fiber  $f^*(s)$  is irreducible and  $(X, S + E)$  has (semi-)log canonical singularities where  $E = f^*(s)^{\text{red}}$ ;

- (ii) an *intermediate fiber* if  $f^*(s)$  is a nodal union of an arithmetic genus-zero component  $A$ , and a possibly nonreduced arithmetic genus-one component supported on a curve  $E$  such that the section meets  $A$  along the smooth locus of  $f^*(s)$  and the pair  $(X, S + A + E)$  has (semi-)log canonical singularities.

Given an elliptic surface  $f: X \rightarrow C$  over the spectrum of a DVR such that  $X$  has an *intermediate fiber* we obtain the *Weierstrass model* of  $X$  by contracting the component  $E$ , and we obtain the *twisted model* by contracting the component  $A$ . As such, the intermediate fiber can be seen to interpolate between the Weierstrass and twisted models.

One can consider a Weierstrass elliptic surface  $(g: Y \rightarrow C, S' + aF')$  over the spectrum of a DVR, where either  $F'$  is a Kodaira singular fiber type, or  $g$  is isotrivial with constant  $j$ -invariant  $\infty$  with  $F'$  being an  $N_k$  fiber type. Then the relative log canonical model  $(f: X \rightarrow C, S + F_a)$  depends on the value of  $a$ . When  $a = 1$  the fiber is in *twisted* form, when  $a = 0$  the fiber is in *Weierstrass form*, and for some  $0 < a_0 < 1$  the fiber enters *intermediate* form. The values  $a_0$  were calculated for all fiber types in [8, Theorem 3.10]:

(2)

fiber type	II	III	IV	$N_1$	$II^*$	$III^*$	$IV^*$	$I_n^*$
$a_0$	$\frac{5}{6}$	$\frac{3}{4}$	$\frac{2}{3}$	$\frac{1}{2}$	$\frac{1}{6}$	$\frac{1}{4}$	$\frac{1}{3}$	$\frac{1}{2}$

We now state the definition of pseudoelliptic surfaces, which appear as components of surfaces in our moduli spaces, a phenomenon first observed by La Nave [33].

**Definition 3.3** A *pseudoelliptic pair* is a surface pair  $(Z, F)$  obtained by contracting the section of an irreducible elliptic surface pair  $(f: X \rightarrow C, S + F')$ . We call  $F$  the *marked pseudofibers* of  $Z$ . We call  $(f: X \rightarrow C, S)$  the associated elliptic surface to  $(Z, F)$ .

The MMP will contract the section of an elliptic surface if it has nonpositive intersection with the log canonical divisor of the surface. There are two types of pseudoelliptic surfaces which appear, and we refer the reader to [8, Definitions 4.6 and 4.7] for the precise definitions.

**Definition 3.4** A pseudoelliptic surface of *type II* is formed by the log canonical contraction of a section of an elliptic component attached along *twisted* or *stable* fibers.



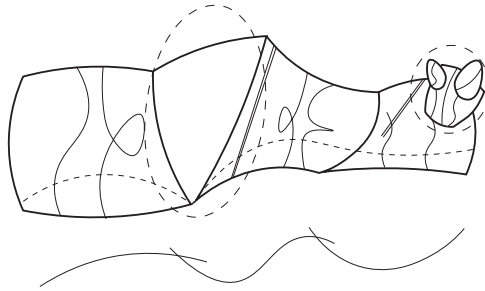

Figure 2: An  $\mathcal{A}$ -broken elliptic surface. Two types of pseudoelliptic surfaces (see Definitions 3.4 and 3.5) are circled: type II (left) and type I (right).

**Definition 3.5** A pseudoelliptic surface of *type I* appears in *pseudoelliptic trees*, attached by gluing an irreducible pseudofiber  $G_0$  on the root component to an arithmetic genus-one component  $E$  of an intermediate (pseudo)fiber of an elliptic or pseudoelliptic component.

Figure 2 has a tree of pseudoelliptic surfaces of type I circled on the right, with a pseudoelliptic of type II circled on the left.

**Theorem 3.6** [8, Theorem 1.6] *The boundary of the proper moduli space  $\mathcal{E}_{v,\mathcal{A}}$  parametrizes  $\mathcal{A}$ -broken stable elliptic surfaces, which are pairs  $(f : X \rightarrow C, S + F_{\mathcal{A}})$  consisting of a stable pair  $(X, S + F_{\mathcal{A}})$  with a map to a nodal curve  $C$  such that  $X$  consists of*

- *an slc union of elliptic surfaces with section  $S$  and marked fibers, as well as*
- *chains of pseudoelliptic surfaces of types I and II (see Definition 3.3) contracted by  $f$  with marked pseudofibers.*

Contracting the section of a component to form a pseudoelliptic component corresponds to stabilizing the base curve as an  $\mathcal{A}$ -stable curve in the sense of Hassett; see [6, Corollaries 6.7 and 6.8]. In particular:

**Theorem 3.7** [8, Theorem 1.4] *There are forgetful morphisms  $\mathcal{E}_{v,\mathcal{A}} \rightarrow \overline{\mathcal{M}}_{g,\mathcal{A}}$ .*

**Remark 3.8** For an irreducible component with base curve  $\mathbb{P}^1$  and  $\deg \mathcal{L} > 0$ , contracting the section of an elliptic component may *not* be the final step in the MMP — we may need to contract the entire pseudoelliptic component to a curve or a point; see [6, Proposition 7.4].

**3.0.1 Wall and chamber structure** We are now ready to discuss how the moduli spaces  $\mathcal{E}_{\mathcal{A}}$  change as we vary  $\mathcal{A}$ . There are three types of walls in our wall and chamber decomposition.

**Definition 3.9** (I) A wall of *type*  $W_I$  is a wall arising from the log canonical transformations, ie the walls where the fibers of the relative log canonical model transition between fiber types.

(II) A wall of *type*  $W_{II}$  is a wall at which the morphism induced by the log canonical transformation contracts the section of some components.

(III) A wall of *type*  $W_{III}$  is a wall at which the morphism induced by the log canonical transformation contracts an entire rational pseudoelliptic component; see Remark 3.8.

**Remark 3.10** (i) The walls of type  $W_{II}$  are precisely the walls of Hassett's wall and chamber decomposition [23]; see discussion preceding Theorem 3.7.

(ii) There are finitely many walls; see [8, Theorem 6.3].

**Theorem 3.11** [8, Theorem 1.5] *Let  $\mathcal{A}, \mathcal{B} \in \mathbb{Q}^r$  be weight vectors with  $0 < \mathcal{A} \leq \mathcal{B} \leq 1$ . Then:*

(i) *If  $\mathcal{A}$  and  $\mathcal{B}$  are in the same chamber, then the moduli spaces and universal families are isomorphic.*

(ii) *If  $\mathcal{A} \leq \mathcal{B}$  then there are reduction morphisms  $\mathcal{E}_{v,\mathcal{B}} \rightarrow \mathcal{E}_{v,\mathcal{A}}$  on moduli spaces which are compatible with the reduction morphisms on the Hassett spaces.*

(iii) *The universal families are related by a sequence of explicit divisorial contractions and flips. More precisely, across  $W_I$  and  $W_{III}$  walls there is a divisorial contraction of the universal family, and across a  $W_{II}$  wall the universal family undergoes a log flip.*

**Remark 3.12** For more on Theorem 3.11(iii), we refer the reader to [8, Section 8]. La Nave (see [33, Section 4.3 and Theorem 7.1.2]) noticed that the contraction of the section of a component is a log flipping contraction inside the total space of a one-parameter degeneration. In particular, the type I pseudoelliptic surfaces are thus attached along the reduced component of an intermediate (pseudo)fiber; see [8, Figure 13].

### 3.1 Strictly (semi-)log canonical Weierstrass models

In order to understand the stable pair degenerations of log canonical models of Weierstrass elliptic surfaces, we need to understand strictly log canonical and semi-log canonical Weierstrass fibrations. We collect some results in this direction here, beginning with the definition of a *type L* singular fiber.

**Definition 3.13** [33, Section 3.3] Let  $f: X \rightarrow C$  be a Weierstrass fibration with smooth generic fiber and Weierstrass data  $(A, B)$ . If  $12 = \min(3v_q(A), 2v_q(B))$ , where  $v_q$  denotes the order of vanishing at a point  $q \in \mathbb{P}^1$ , we say that  $f$  has a *type L fiber* at  $q$ .

**Lemma 3.14** If  $F$  is a type L cusp of  $X$ , then  $X$  has strictly log canonical singularities in a neighborhood of  $F$  and the log canonical threshold  $\text{lct}(X, 0, F)$  equals 0.

**Proof** After performing a weighted blowup  $\mu: Y \rightarrow X$  at the cuspidal point of  $F$ , we get an exceptional divisor  $E$  (a possibly nodal elliptic curve) and strict transform  $A := \mu_*^{-1}(F)$  (a rational curve meeting  $E$  transversely). Writing  $\mu^*K_X = K_Y + aE$ , it follows from the projection formula that  $K_Y \cdot E + aE^2 = 0$ . On the other hand,  $K_Y \cdot E + E^2 = K_E = 0$  by the adjunction formula and  $E^2 \neq 0$ , since it is exceptional. Therefore  $a = 1$ , so  $X$  has a strictly log canonical singularity at the cuspidal point of  $F$ , and the discrepancy of  $(X, \epsilon F)$  for any  $\epsilon > 0$  will be strictly greater than 1.  $\square$

**Remark 3.15** The type L cusp decreases the self intersection  $S^2$  by 1, and thus increases  $\text{deg } \mathcal{L}$  by 1; see [33, Remark 5.3.8].

We now discuss some facts on nonnormal Weierstrass fibrations with generic fiber a nodal elliptic curve. These appear as semi-log canonical degenerations of normal elliptic surfaces and as isotrivial  $j$ -invariant  $\infty$  components of broken elliptic surfaces.

We first recall the definition of the fiber types  $N_k$  of these fibrations; see [6, Section 5] and [33, Lemma 3.2.2].

**Definition 3.16** Fibers of type  $N_k$  have Weierstrass equation  $y^2 = x^2(x - t^k)$ .

**Lemma 3.17** [33, Lemma 3.2.2] Fibers of type  $N_k$  are slc if and only if  $k \in \{0, 1, 2\}$ .

**Remark 3.18** (i) The general fiber of an isotrivial  $j$ -invariant  $\infty$  fibration is type  $N_0$ .

(ii)  $N_2$  is the  $j$ -invariant  $\infty$  version of the L cusp; see Remark 3.19.

**Remark 3.19** The  $N_2$  fiber behaves analogously to the type L fiber. Indeed by the proof of [6, Lemma 5.1], on the normalization  $(X^\nu, D)$  of a surface  $X$  with an  $N_2$  fiber, the double locus  $D$  consists of a nodal curve with node lying over the cuspidal point of the  $N_2$  fiber, and  $X^\nu$  is smooth in a neighborhood of this point. In particular,  $(X^\nu, D)$  has log canonical singularities in a neighborhood of the nodal point of  $D$  and  $\text{lct}(X^\nu, D, A) = 0$  for any curve  $A$  passing through this point. Therefore by the definition of semi-log canonical,  $X$  has strictly semi-log canonical singularities in a neighborhood of the  $N_2$  fiber  $F$  and  $\text{slct}(X, 0, F) = 0$ .

The local equation given above for a type  $N_k$  fiber is not a standard Weierstrass equation. One can check that the standard equation of an  $N_k$  fiber is given by

$$(3) \quad y^2 = x^3 - \frac{1}{3}t^{2k}x + \frac{2}{27}t^{3k}.$$

**Proposition 3.20** *If  $(f: X \rightarrow C, S)$  is an isotrivial  $j$ -invariant  $\infty$  slc Weierstrass fibration with  $a_k$  type  $N_k$  fibers, then  $-S^2 = \deg(\mathcal{L}) = \sum_k a_k \frac{1}{2}k$ .*

**Proof** Let  $A$  and  $B$  the Weierstrass data of  $(f: X \rightarrow C, S)$ . If  $q \in C$  lies under an  $N_k$  fiber, then  $A$  vanishes to order  $2k$  and  $B$  to order  $3k$  at  $q$ . Then  $A$  and  $B$  have degree  $\sum 2ka_k$  and  $\sum 3ka_k$ , respectively. The result follows since the degrees of  $A$  and  $B$  are  $4 \deg \mathcal{L}$  and  $6 \deg \mathcal{L}$ , respectively.  $\square$

Note that for  $k$  even the  $N_k$  fiber has trivial monodromy, and for  $k$  odd it has  $\mu_2$  monodromy. This determines the twisted models of these fibers.

**Corollary 3.21** *Let  $F$  be an  $N_k$  fiber. Then the twisted model of  $F$  is an  $N_0$  (respectively twisted  $N_1$ ) fiber if  $k$  is even (respectively odd).*

**Proof** By the local analysis of [7, Section 6.2], in the even case the twisted model must be stable since there is no base change required, and the odd case there is a  $\mu_2$  base change so the twisted model is a nodal cubic curve modulo the  $\mu_2$  action, ie a twisted  $N_2$  fiber.  $\square$

Thus, given an  $N_k$  fiber, we can cut it out and glue in an  $N_{k+2}$  fiber since the families are isomorphic to  $N_0$  (respectively  $N_1$ ) families over a punctured neighborhood. We can ask how this surgery affects  $-S^2 = \deg \mathcal{L}$ .

**Corollary 3.22** *Let  $(f: X \rightarrow C, S)$  be an isotrivial  $j$ -invariant  $\infty$  Weierstrass fibration and let  $(f: X' \rightarrow C, S')$  be the result of replacing an  $N_k$  fiber by an  $N_{k+2}$  fiber. Then  $-(S')^2 = -S^2 + 1$ .*

### 3.2 Elliptic fibrations via twisted stable maps

In [7] we used the theory of twisted stable maps, originally developed by Abramovich and Vistoli [1; 2], to understand limits of families of elliptic fibrations. The basic idea is that an elliptic surface  $f : X \rightarrow C$  gives an a priori rational map  $C \dashrightarrow \overline{\mathcal{M}}_{1,1}$  which extends to a morphism  $\mathcal{C} \rightarrow \overline{\mathcal{M}}_{1,1}$  from an orbifold curve  $\mathcal{C}$  with coarse moduli space  $C$ . Now we understand limits of a family of elliptic surfaces by computing limits of the corresponding family of such maps. The twisted stable limits serve the same purpose for elliptic fibrations that *Kulikov models* serve for K3 surfaces, ie they form the starting point from which applying the MMP yields the stable limit.

**3.2.1 Twisted stable maps limits** We now recall structure of the limiting surfaces obtained using the twisted stable maps construction. As we will be studying slc degenerations of surfaces, the surfaces themselves will degenerate into possibly reducible surfaces. The degenerate surfaces will carry a fibration over a nodal curve whose  $j$ -map is the limit of the  $j$ -map of the degenerating family. Furthermore, there is a *balancing condition* on the stabilizers of the orbicurve  $\mathcal{C}$  over nodes, which implies the action on the tangent spaces of the two branches at a node must be dual; see [1, Definition 3.2.4] and [40]. Finally, the stabilizers of a twisted stable map are concentrated either over nodes or at marked gerbes contained in the smooth locus. In particular, the limit of a map from a smooth schematic curve  $C$  can only have stabilizers over the nodes.

These observations motivate the following necessary conditions for a twisted surface to appear as a limit of a family of degenerating elliptic surfaces. We consider the case where the degenerating family of elliptic surfaces has  $12dI_1$  marked singular fibers where  $d = \deg \mathcal{L}$ , as this is the generic situation and the relevant one for the present paper. This corresponds to the moduli map  $C \rightarrow \overline{\mathcal{M}}_{1,1}$  extending to a morphism on all of  $\mathcal{C}$  such that the  $j$ -map  $C \rightarrow \overline{\mathcal{M}}_{1,1} \cong \mathbb{P}^1$  has degree  $12d$ , and is unramified over  $\infty$ .

**Proposition 3.23** *Suppose  $(f : X \rightarrow C, S + F)$  is a twisted elliptic surface [7] over a rational curve which is the limit of a degenerating family of smooth elliptic surfaces with  $12dI_1$  and arbitrary marked fibers. Then:*

- (i) *If  $X$  is reducible, its irreducible components are either attached along nodal fibers, or in the pairs of twisted fibers  $I_a^*/I_b^*/N_1, II/II^*, III/III^*$  or  $IV/IV^*$ .*
- (ii) *The total degree of the  $j$ -map  $C \rightarrow \overline{\mathcal{M}}_{1,1}$  is  $12d$ .*
- (iii) *Away from the singular locus of  $C$ , the fibers of  $f$  are at worst nodal. In particular, every marked fiber in  $F = \sum_{i=1}^n F_i$  is an  $I_a$  fiber for some  $a \geq 0$ .*

The surfaces of Proposition 3.23 correspond to genus-zero balanced twisted stable maps to  $\overline{\mathcal{M}}_{1,1}$  of degree  $12d$  which are parametrized by the space  $\mathcal{K}_{0,n}(\overline{\mathcal{M}}_{1,1}, 12d)(\underline{0})$ . Here  $\underline{0}$  is the tuple of  $n$  zeroes, denoting the fact that the marked points have trivial stabilizer.

**Theorem 3.24** [9, Theorem 5.5] *Each point*

$$[(f: \mathcal{C} \rightarrow \overline{\mathcal{M}}_{1,1}, p_1, \dots, p_n)] \in \mathcal{K}_{0,n}(\overline{\mathcal{M}}_{1,1}, 12d)(\underline{0})$$

*admits a smoothing to a map from a nonsingular  $n$ -pointed schematic rational curve.*

**Corollary 3.25** *A twisted elliptic surface admits a smoothing to a generic  $12dI_1$  elliptic surface if and only if it satisfies the conditions of Proposition 3.23.*

**3.2.2 Relative twisted stable maps** One of the primary moduli spaces of interest from the perspective of stable pairs is the closure of the locus where the marked fibers are exactly the  $12dI_1$  fibers. These fibers lie above the preimages of  $\infty \in \overline{\mathcal{M}}_{1,1}$  under the  $j$ -invariant map  $C \rightarrow \overline{\mathcal{M}}_{1,1}$ , and thus we are concerned with the closure  $\mathcal{K}_\infty \subset \mathcal{K}_{0,24}(\overline{\mathcal{M}}_{1,1}, 24)$  of the locus parametrizing maps from a smooth rational curve which are unramified over  $\infty$  and such that all marked fibers map to  $\infty$ . Equivalently, this locus is the space of maps *relative to the divisor*  $[\infty]$  with multiplicities  $(1, \dots, 1)$ . The closure of such loci has been studied in the Gromov–Witten literature under the name of *relative stable maps*; see eg [13; 17; 45]. In [9], we considered the question of determining the points of this locus for twisted stable maps to stacky curves. The conditions characterizing this locus [9, Conditions (\*)] can be phrased in the context of elliptic fibrations:

**Proposition 3.26** *Suppose  $(f: X \rightarrow C, S + F)$  is a twisted elliptic surface over a rational curve which is the limit of a degenerating family of  $12dI_1$  elliptic surfaces with marked singular fibers. Then the following hold in addition to the conditions of Proposition 3.23:*

- (i)  *$F$  consists of  $12d$  nodal singular fibers.*
- (ii) *Every fiber with  $j = \infty$  which is not on an isotrivial component is marked.*
- (iii) *For each maximal connected tree  $T$  of isotrivial  $j = \infty$  components  $X$ , the number of marked fibers contained on  $T$  is equal to the sum of the multiplicities of the twisted fibers of the nonisotrivial components along which  $T$  is attached.*

**Remark 3.27** The last condition says that if an isotrivial  $j$ -invariant  $\infty$  component is attached to an  $I_n$  fiber, there must be  $n$  markings on that component, since an  $I_n$  fiber is produced when  $n$  marked  $I_1$  fibers collide.

**Theorem 3.28** [9, Theorems 1.7 and 1.8] *The conditions of Proposition 3.26 characterize the boundary of  $\mathcal{K}_\infty$ . In particular, any twisted surface satisfying these conditions is the limit of a family of smooth  $12dI_1$  elliptically fibered surface with marked singular fibers.*

**Remark 3.29** After determining the shape of a twisted stable maps limit, we will use wall-crossing to compute the limits as one reduces weights.

## 4 Moduli of weighted stable elliptic K3 surfaces

In this section we specialize the discussion of Section 3 to the case of elliptic K3 surfaces and define the various compactifications of the stack  $\mathcal{W}$  of elliptic K3 surfaces and its coarse space  $W$  which we need. The goal is to obtain an *explicit* description of the compactifications for various choices of weights  $\mathcal{A}$ . In particular, we will explicitly describe the surfaces parametrized by the boundary of  $\mathcal{E}_{\mathcal{A}}$  in this case, as well as understand the wall-crossing morphisms.

From now on we assume that  $g(C) = 0$  and  $\deg \mathcal{L} = 2$  so that  $C \cong \mathbb{P}^1$  and  $\mathcal{L} = \mathcal{O}_{\mathbb{P}^1}(2)$ , and  $(f: X \rightarrow C, S)$  is an elliptic K3 surface with section.

**Definition 4.1** Let  $\overline{\mathcal{W}}(\mathcal{A})$  be the closure in  $\mathcal{E}_{\mathcal{A}}$  of the locus of pairs  $(f: X \rightarrow C, S + F_{\mathcal{A}})$  where  $X$  is an elliptic K3 surface and  $\text{Supp}(F_{\mathcal{A}})$  consists of  $24 I_1$  singular fibers.

**Definition 4.2** If  $\mathcal{A} = (a, \dots, a)$  is the constant weight vector, then  $S_{24}$  acts on  $\overline{\mathcal{W}}(\mathcal{A})$  by permuting the marked fibers, and we denote the quotient by  $\overline{\mathcal{W}}_\sigma(a)$ .

**Proposition 4.3**  $\overline{\mathcal{W}}(\mathcal{A})$  and  $\overline{\mathcal{W}}_\sigma(a)$  are proper Deligne–Mumford stacks. Moreover, the coarse space  $\overline{W}_\sigma(a)$  of  $\overline{\mathcal{W}}_\sigma(a)$  is a modular compactifications of  $W$  for each  $0 < a \leq 1$ .

**Proof** The fact that they are proper Deligne–Mumford stacks follows from [8]. By construction,  $\overline{\mathcal{W}}_\sigma(a)$  has an open set parametrizing elliptic K3s with  $24I_1$  fibers. Recall that  $W$  parametrizes lattice polarized K3 surfaces, and such a lattice polarization is equivalent to the structure of an elliptic fibration with chosen section. The result follows by the observation that a generic elliptically fibered K3 surface has  $24I_1$  fibers.  $\square$

Brunyate constructs a compactification  $\overline{\mathcal{B}}$  of the space of elliptic K3 surfaces by studying degenerations of pairs  $(X, \epsilon_1 S + F_B)$  where  $\mathcal{B} = (\epsilon, \dots, \epsilon)$ , ie with small weights on both the section and the fibers (in particular, Brunyate requires  $\epsilon_1 \ll \epsilon$ ), so that  $\text{Supp}(F_B)$  is the closure of the rational curves on  $X$  [12]; see also [4, Section 7]. In fact there is a morphism  $\overline{\mathcal{B}}^\nu \rightarrow \overline{\mathcal{W}}_\sigma(\epsilon)$ , given by increasing the weight on the section to 1.

**Proposition 4.4** *There is a morphism  $\overline{\mathcal{B}}^\nu \rightarrow \overline{\mathcal{W}}_\sigma(\epsilon)$  for  $\epsilon \ll 1$ .*

**Proof** Consider a 1-parameter degeneration of pairs  $(X, \epsilon S + F_B)$  inside  $\overline{\mathcal{B}}$ . We may generically choose smooth fibers  $G = \bigcup_{i \in I} G_i$  to mark so that the pair  $(X, S + F_B + G)$  is stable, where the section has coefficient 1. By the results of [8], there is a sequence of flips and contractions as one reduces the coefficients of  $G$  from 1 to 0. The resulting stable limit in  $\overline{\mathcal{W}}_\sigma(\epsilon)$  only depends on the point  $(X_0, \epsilon S_0 + (F_B)_0)$  in  $\overline{\mathcal{B}}$  and not on the family or choice of auxiliary markings. Therefore we obtain the desired morphism by [18, Theorem 7.3].  $\square$

**Remark 4.5** Comparing Theorem 6.13 with [12, Theorem 9.1.4] (see also [4, Section 7]), we see that there is a bijection between the boundary strata of  $\overline{\mathcal{B}}$  and  $\overline{\mathcal{W}}_\sigma(\epsilon) = \mathcal{W}(\mathcal{B})/S_{24}$ . For example, the third case in [12, Theorem 9.1.4] maps to case (E) of Theorem 6.13 if there are no  $\mathbb{F}_0$  components, and to either case (D) or (F) depending on the parity of the number of components if there are  $\mathbb{F}_0$  components.

**Corollary 4.6** *The morphism from Proposition 4.4 is an isomorphism.*

**Proof** It is a proper birational set-theoretic bijection between normal spaces.  $\square$

**Remark 4.7** It follows from Corollary 4.6 that there is in fact a morphism  $\overline{\mathcal{W}}_\sigma(\epsilon) \rightarrow \overline{\mathcal{B}}$  which can be thought of as induced by decreasing weights on the section.

**Definition 4.8** Let  $\overline{\mathcal{K}}_\epsilon$  denote stable pairs compactification of the space parametrizing pairs with only one singular fiber marked with weight  $0 < \epsilon \ll 1$ , and let  $\overline{\mathcal{K}}_\epsilon$  be its coarse moduli space.

Next we define the moduli space  $\overline{\mathcal{F}}_\epsilon$ , which is like  $\overline{\mathcal{K}}_\epsilon$ , only we allow *any* fiber to be marked.

**Definition 4.9** Let  $\overline{\mathcal{F}}_\epsilon$  be the closure in  $\mathcal{E}_A$  of the locus of pairs  $(f: X \rightarrow C, S + \epsilon F)$ , where  $f$  has precisely 24  $I_1$  fibers,  $0 < \epsilon \ll 1$ , and  $F$  is any fiber.



**Remark 4.10** At this point we have introduced many compactifications (see Figure 1 and the list on page 1894):

- $\overline{\mathcal{W}}(\mathcal{A})$  The stable pair compactification with  $\mathcal{A}$ -weighted singular fibers.
- $\overline{\mathcal{W}}_\sigma(a)$  The quotient by  $S_{24}$  when  $\mathcal{A} = (a, \dots, a)$ .
- $\overline{\mathcal{K}}_\epsilon$  The stable pairs compactification with a single  $\epsilon$ -marked singular fiber.
- $\overline{\mathcal{F}}_\epsilon$  The stable pairs compactification with *any fiber* marked by  $\epsilon$ .
- $\overline{\mathcal{W}}^*$  The SBB compactification of the period domain moduli space  $W$ .

We now give a brief overview of how they are related (again, see Figure 1).

- (i) There are 24 generically finite morphisms  $\overline{\mathcal{W}}(\mathcal{A}) \rightarrow \overline{\mathcal{K}}_\epsilon$  of degree  $23!$ , corresponding to forgetting all but one marked singular fiber.
- (ii) There is a degree 24 generically finite rational map  $\overline{\mathcal{K}}_\epsilon \dashrightarrow \overline{\mathcal{W}}_\sigma(\epsilon)$ , corresponding to choosing a singular fiber.
- (iii) There are morphisms  $\overline{\mathcal{W}}_\sigma(\epsilon) \rightarrow \overline{\mathcal{W}}^*$  and  $\overline{\mathcal{K}}_\epsilon \rightarrow \overline{\mathcal{W}}^*$ ; see Theorems 6.15 and 8.2, respectively.
- (iv) We will see in Section 8.3 that the moduli space  $\overline{\mathcal{F}}_\epsilon$  is a smooth Deligne–Mumford stack whose coarse space is an (explicit) GIT quotient. Furthermore, there is a morphism  $\overline{\mathcal{F}}_\epsilon \rightarrow \overline{\mathcal{W}}^*$  (see Theorem 8.8) which is generically a  $\mathbb{P}^1$  bundle.

We end this section with an important proposition.

**Proposition 4.11** *For any surface  $X$  parametrized by  $\overline{\mathcal{W}}(\mathcal{A})$  (for any  $\mathcal{A}$ ) or  $\overline{\mathcal{F}}_\epsilon$  (in particular  $\overline{\mathcal{K}}_\epsilon$ ), we have  $H^1(X, \mathcal{O}_X) = 0$ .*

**Proof** Since slc singularities are Du Bois [26, Corollary 6.32; 29],  $X$  has Du Bois singularities. Then  $H^1(X, \mathcal{O}_X) = 0$  since  $H^i(X_b, \mathcal{O}_{X_b})$  is constant in any flat family of varieties with Du Bois singularities [29, Corollary 1.2], and any  $X$  arises as the special fiber of a flat family whose general fiber is a surface  $X_\eta$  with  $H^1(X_\eta, \mathcal{O}_{X_\eta}) = 0$ .  $\square$

**Remark 4.12** We will see in Theorem 8.1 that the surfaces on the boundary of  $\overline{\mathcal{F}}_\epsilon$  (and thus also  $\overline{\mathcal{K}}_\epsilon$ ) satisfy  $\omega_X \cong \mathcal{O}_X$ . Moreover, if  $F$  is the marked fiber, then  $2F$  is an ample Cartier divisor such that  $(2F)^2 = 2$ . Then following [5, Definition 3.4, Proposition 3.8, and Theorem 3.11], we see that  $\overline{\mathcal{F}}_\epsilon$  and  $\overline{\mathcal{K}}_\epsilon$  are proper Deligne–Mumford stacks representing a functor over arbitrary base schemes. Due to subtleties with defining moduli spaces in higher dimensions, the remaining spaces follow the formalism developed in [8] and thus correspond to Deligne–Mumford stacks representing functors only over *normal* base schemes; see [8, Section 2.2.2] for more details.

#### 4.1 Isotrivial $j$ -invariant $\infty$ fibrations

Here we prove some preliminary results on isotrivial  $j$ -invariant  $\infty$  elliptic fibrations of K3 type which appear in the boundary of the various moduli spaces described above. We begin by bounding the number of  $N_i$  fibers (see Definition 3.16) which can appear on an slc elliptic K3.

**Proposition 4.13** *Let  $(f : X \rightarrow \mathbb{P}^1, S)$  be an isotrivial  $j = \infty$  slc Weierstrass fibration of K3 type. Then  $X$  has one of the following configurations of cuspidal fibers:*

- (i)  $4N_1$ ,
- (ii)  $2N_1N_2$ , or
- (iii)  $2N_2$ .

**Proof** We must have only  $N_0, N_1$  and  $N_2$  by the slc assumption, so, by Proposition 3.20,  $2 = \frac{1}{2}a_1 + a_2$ , which only admits the nonnegative integer solutions  $(4, 0)$ ,  $(2, 1)$  and  $(0, 2)$  for  $(a_1, a_2)$ .  $\square$

**Remark 4.14** Up to automorphisms of  $\mathbb{P}^1$ , the global Weierstrass equation for the surfaces in Proposition 4.13 can be written as follows:

- (i)  $y^2 = x^3 - \frac{1}{3}t^2s^2(t-s)^2(t-\lambda s)^2x + \frac{2}{27}t^3s^3(t-s)^3(t-\lambda s)^3$  for  $\lambda \in \mathbb{P}^1 \setminus \{0, 1, \infty\}$ .
- (ii)  $y^2 = x^3 - \frac{1}{3}t^2s^2(t-s)^4x + \frac{2}{27}t^3s^3(t-s)^6$ .
- (iii)  $y^2 = x^3 - \frac{1}{3}t^4s^4x + \frac{2}{27}t^6s^6$ .

In particular, up to isomorphism there are unique surfaces with configurations (ii) and (iii).

Finally, we need the following key proposition.

**Proposition 4.15** *Suppose  $(f_0 : X \rightarrow \mathbb{P}^1, S)$  is an isotrivial  $j = \infty$  slc Weierstrass fibration of K3 type and  $F \subset X$  is an  $N_k$  fiber. If  $f_0$  is the central fiber of a 1-parameter family of Weierstrass models  $(f : \mathcal{X} \rightarrow \mathcal{C}, \mathcal{S}) \rightarrow B$  with generic fiber  $(f_\eta : \mathcal{X}_\eta \rightarrow C_\eta, \mathcal{S}_\eta)$  a  $24I_1$  elliptic fibration, then there are at least  $k + 1$  type  $I_1$  fibers of  $f_\eta$  that limit to the  $N_k$  fiber  $F$  for  $k = 1, 2, 3, 4$ .*

**Proof** Consider the twisted stable maps limit of  $f_\eta$ . By Proposition 3.23(i), the Weierstrass  $N_1$  fiber  $F$  must be replaced by a surface component  $Y$  attached along the twisted model of  $F$  by a twisted fiber of type  $I^*$  (resp.  $I$ ) if  $k$  is odd (resp. even).

By Proposition 4.13, the possibilities for  $X$  are  $4N_1$ ,  $2N_1N_2$  and  $2N_2$ , as well as the non-slc cases  $N_1N_3$  and  $N_4$ . Since the degree of the  $j$ -map is constant for a family of twisted stable maps, the sum of degrees of the  $j$ -map of the components of the twisted model is 24. This means that  $Y$  is rational when  $k = 1, 2$  and K3 when  $k = 3, 4$ . The number of  $I_1$  fibers of  $f_\eta$  limiting to the  $N_1$  fiber  $F$  of  $f_0$  is the same as the number of  $I_1$  fibers limiting to the component  $Y$  in the twisted model. By Proposition 3.23(ii)–(iii), the component  $Y$  cannot be isotrivial and  $\deg(\mathcal{L}) \geq 1$ . By Persson’s classification [41], a rational elliptic surface  $Y$  with an  $I^*$  fiber has at least  $2I_1$  fibers, and one with an  $I_n$  fiber has at least three other  $I_1$  fibers counted with multiplicity. Similarly, by [44, Theorems 1.1 and 1.2], an elliptic K3 surface with an  $I^*$  fiber has at least  $4I_1$  fibers, and one with an  $I_n$  fiber has at least five other  $I_1$  fibers counted with multiplicity. □

### 5 Wall crossings inside $\overline{\mathcal{W}}_\sigma(a)$ for $a > \frac{1}{12}$

Recall that  $\overline{\mathcal{W}}_\sigma(a)$  denotes the space where all singular fibers are marked with weight  $a$  and we have taken the  $S_{24}$  quotient. The main goal of this section is to describe the surfaces parametrized by  $\overline{\mathcal{W}}_\sigma(\frac{1}{12} + \epsilon)$  for  $0 < \epsilon \ll 1$ . In particular, we explicitly describe the wall crossings that happen as we vary the weight vector from  $a = 1$  to  $a = \frac{1}{12} + \epsilon$ .

By Corollary 5.6 we see that surfaces parametrized by  $\overline{\mathcal{W}}_\sigma(a)$  have *at most* two elliptically fibered components, but possibly with trees of pseudoelliptic surfaces attached to them. In Proposition 5.15 we classify the possible surfaces parametrized by  $\overline{\mathcal{W}}_\sigma(a)$  with a *single normal elliptically fibered component*. In Theorem 5.16 we classify the possible surfaces parametrized by  $\overline{\mathcal{W}}_\sigma(a)$  with a *single nonnormal elliptically fibered component*. In Theorem 5.19, we classify the possible surfaces parametrized by  $\overline{\mathcal{W}}_\sigma(a)$  with *two elliptically fibered components*. Finally, in Propositions 5.18 and 5.20, we show that surfaces of each type appearing in the aforementioned results do exist on the boundary of  $\overline{\mathcal{W}}_\sigma(a)$ .

**Lemma 5.1** *There are type  $W_{II}$  walls where type I pseudoelliptic surfaces form at  $a = 1/k$  for  $k = 1, \dots, 11$ .*

**Proof** Recall that type I pseudoelliptic surfaces form when a component of the underlying weighted curve is contracted—this occurs when  $ka = 1$ . Finally, note that  $24a > 2$  for each of these values of  $k$ , so the moduli space is nontrivial. □

**Lemma 5.2** *There are type  $W_{III}$  walls at  $a = \frac{5}{12}, \frac{3}{12}$  and  $\frac{2}{12}$  where rational pseudo-elliptic surfaces attached along intermediate type II, III and IV fibers, respectively, contract to a point.*

**Proof** This follows from [8, Theorem 6.3] as well as the observation that a rational elliptic surface attached to a type II, III or IV fiber must have a  $II^*$ ,  $III^*$  or  $IV^*$  fiber, respectively, and so it has 2, 3 or 4 other marked fibers counted with multiplicity.  $\square$

Since these walls are all above  $\frac{1}{12}$ , we obtain:

**Corollary 5.3** *Any type II, III or IV fiber on a surface parametrized by  $\overline{W}_\sigma(\frac{1}{12} + \epsilon)$  is a Weierstrass fiber. In particular, there are no pseudoelliptic trees sprouting off of it.*

In a similar vein we have the following two lemmas:

**Lemma 5.4** *There are type  $W_{III}$  walls at  $a = \frac{1}{4}, \frac{1}{6}, \frac{1}{8}$  and  $\frac{1}{10}$ , where:*

- (i) *Rational pseudoelliptic surfaces attached along intermediate type  $N_1$  fibers contract onto a point.*
- (ii) *Isotrivial  $j$ -invariant  $\infty$  surfaces with  $\deg \mathcal{L} = 1$  attached along intermediate type  $N_1$  fibers contract onto a point.*

**Proof** A rational elliptic surface attached along an  $N_1$  fiber must have an  $I_k^*$  fiber in the double locus. Since an  $I_k^*$  has discriminant  $6 + k$ , there are  $6 - k$  markings counted with multiplicity on the rational pseudoelliptic. By the classification in [41], there exist rational elliptic surfaces with  $I_k^*$  for  $0 \leq k \leq 4$ . Since the log canonical threshold of an intermediate  $N_1$  fiber is  $\frac{1}{2}$ , the surfaces with an  $N_1/I_k^*$  double locus contract at  $1/(2(6 - k))$ . These give walls above  $\frac{1}{12}$  for  $1 \leq k \leq 4$ . Similarly, isotrivial  $j$ -invariant  $\infty$  surfaces with an  $N_1$  fiber and  $\deg \mathcal{L} = 1$  must be attached along another  $N_1$  fiber and so contract at  $1/(2k)$ , where they support  $k$  fibers.  $\square$

Next we consider the base curve at  $\frac{1}{12} + \epsilon$ :

**Lemma 5.5** *Let  $\mathcal{A} = (a, \dots, a)$  for  $a = \frac{1}{12} + \epsilon$ . Then curves  $C$  parametrized by  $\overline{\mathcal{M}}_{0,\mathcal{A}}$  are either*

- (i) *a smooth  $\mathbb{P}^1$  with 24 marked points, with at most 11 markings coinciding, or*
- (ii) *the union of two rational curves, each with 12 marked points and at most 11 markings coinciding.*

**Proof** If  $C$  is a smooth  $\mathbb{P}^1$ , since the total weight for any marking is at most 1, we see that at most 11 points can coincide. If  $C$  is the union of two rational curves, since each point is weighted by  $\frac{1}{12} + \epsilon$  and since each curve needs total weight greater than 2 (including the node), each curve must have (exactly) 12 points, and again at most 11 can coincide. Finally, suppose  $C$  is the union of three components  $C = \bigcup_{i=1}^3 C_i$  with  $C_1$  and  $C_3$  the end components. Since the  $C_2$  component needs at least one marking to be stable, at least one of  $C_1$  and  $C_3$  will not have enough marked points to be stable.  $\square$

**Corollary 5.6** Let  $(f : X \rightarrow C, S + F_a)$  be a surface pair parametrized by  $\overline{\mathcal{W}}_\sigma(\frac{1}{12} + \epsilon)$ . Then  $f : X \rightarrow C$  has at most two elliptically fibered components.

**Remark 5.7**  $X$  can have many type I pseudoelliptic components mapping by  $f$  onto marked points of  $C$ .

**Definition 5.8** If  $(f : X \rightarrow C, S + F_a)$  is a surface pair parametrized by  $\overline{\mathcal{W}}_\sigma(\frac{1}{12} + \epsilon)$ , the *main component* of  $X$ , denoted by  $X_m$ , is the union of all elliptically fibered components of  $f : X \rightarrow C$ .

**Remark 5.9** By Corollary 5.6, for all surfaces pairs parametrized by  $\overline{\mathcal{W}}_\sigma(\frac{1}{12} + \epsilon)$ , either  $X_m$  and  $C$  are irreducible or  $X_m = X_1 \cup X_2$  and  $C = C_1 \cup C_2$ , where  $X_i$  and  $C_i$  are irreducible and  $f|_{X_i} : X_i \rightarrow C_i$  is an elliptic fibration.

### 5.1 Explicit classification of surfaces inside $\overline{\mathcal{W}}_\sigma(\frac{1}{12} + \epsilon)$

We conclude that every surface parametrized by  $\overline{\mathcal{W}}_\sigma(\frac{1}{12} + \epsilon)$  consists of a main component (see Definition 5.8) possibly with trees of pseudoelliptics sprouting off. In order to do understand the possible main components  $X_m$  parametrized by  $\overline{\mathcal{W}}_\sigma(\frac{1}{12} + \epsilon)$ , we will use the following construction of a Weierstrass model for  $X_m$ .

#### 5.1.1 Construction of a family of Weierstrass models

Let

$$(f_0 : X_0 \rightarrow C_0, S_0 + (F_a)_0)$$

be an elliptic surface pair parametrized by  $\overline{\mathcal{W}}_\sigma(\frac{1}{12} + \epsilon)$ , which by Corollary 5.6 has at most two elliptic components. Consider a 1-parameter family  $(f : \mathcal{X} \rightarrow \mathcal{C}, \mathcal{S} + \mathcal{F}_a) \rightarrow T$  with generic fiber  $(f : X_\eta \rightarrow C_\eta, S_\eta + (F_a)_\eta)$ , a  $24I_1$  elliptic K3 surface, and special fiber  $X_0$ . Let  $\mathcal{C}_\eta$  be a generic smooth fiber of the elliptic fibration  $f : \mathcal{X} \rightarrow \mathcal{C}$  such that

the closure  $\mathcal{G}$  is a generic smooth fiber of  $f_0: X_0 \rightarrow C_0$ . In particular,  $G_0 = \mathcal{G}_0$  avoids any pseudoelliptic trees of  $X_0$ .

Let  $Y_0$  denote the irreducible component of  $X_0$  on which  $G_0$  lies. The component  $Y_0$  is necessarily elliptically fibered, and so either  $Y_0 = X_m$  is the main component or  $X_m = Y_0 \cup_{H_0} Y_1$  glued along a twisted fiber  $H_0$ . To classify the possible elliptically fibered components of  $X_0$ , we will take the relative log canonical model of the pair  $(\mathcal{X}, \mathcal{S} + \mathcal{G}) \rightarrow T$  using the main results of [8].

First, if  $X_m = Y_0 \cup Y_1$ , there is a type  $W_{II}$  crossing causing a flip of the section of  $Y_1$  such that  $Y_1$  becomes a type I pseudoelliptic. Then in either case we have a new family where  $Y_0$  is the unique elliptically fibered component with trees of type I pseudoelliptic surfaces sprouting off of it. We make the following assumption, and revisit it when we see it holds in Lemmas 5.13 and 5.14:

**Assumption 5.10** Suppose every type I pseudoelliptic tree attached to  $Y_0$  is attached along the intermediate model of a log canonical Weierstrass cusp.

There exists a sequence of type  $W_{III}$  extremal contractions followed by a type  $W_{III}$  relative log canonical morphism of the family that contract the trees of type I pseudoelliptic components to a point, resulting in a Weierstrass model  $Y'$  of  $Y_0$ . Denote the resulting family of surfaces by  $\mathcal{X}' \rightarrow T$ .

Since type  $W_{III}$  contractions preserve the generic fiber of the family  $\mathcal{X} \rightarrow T$ , we must only check type  $W_{II}$  contractions of the section  $S$ . By [25, Proposition 5.9], we may blow up the point to which the section has contracted to preserve the generic fiber of the family, and so we have that  $\mathcal{X}'_\eta = \mathcal{X}$ . The resulting family of fibrations  $(\mathcal{X}' \rightarrow \mathcal{C}) \rightarrow T$  is a family of slc Weierstrass models over  $\mathbb{P}^1$  with  $\deg(\mathcal{L}) = 2$ , generic fiber a  $24I_1$  elliptic K3, and special fiber  $Y'$ . By Remark 3.15, we can conclude that  $Y'$  is one of the following Weierstrass limits:

- (i) a minimal Weierstrass elliptic K3 surface ( $\deg \mathcal{L} = 2$ ),
- (ii) a rational elliptic surface with a single type L cusp, or
- (iii) an isotrivial elliptic surface with two type L cusps and all other fibers stable.

By considering the discriminant of  $\mathcal{X}' \rightarrow \mathcal{C}$  as a flat family of divisors on  $\mathcal{C}$ , we have the following key observation:

**Remark 5.11** Suppose  $Y' \rightarrow C_0$  is normal. The number of  $I_1$  fibers of the generic fibration  $X_\eta \rightarrow C_\eta$  that collide onto a singular fiber  $F$  of  $Y' \rightarrow C_0$  is the multiplicity of  $F$  in the discriminant of the Weierstrass model  $Y' \rightarrow C_0$ .

We can use this observation to constrain the possible components of the twisted stable maps limit of  $(f: \mathcal{X}_\eta \rightarrow \mathcal{C}_\eta, \mathcal{S}_\eta + \mathcal{F})$ . In this limit, the singular fibers  $(f: \mathcal{X}_\eta \rightarrow \mathcal{C}_\eta)$  cannot collide since they are marked with coefficient one. Let  $Y''$  be the unique component of a twisted model that maps birationally to the component  $Y'$  in the above family of Weierstrass models. Then each connected component of the complement of  $Y''$  is a tree of twisted surfaces that gets collapsed onto a fiber of  $Y''$  by the sequence of flips and contractions that produce the Weierstrass model above. In particular the number of marked fibers on each tree of elliptic components sprouting off a fiber of  $Y''$  is exactly the multiplicity of the discriminant of the resulting singular fiber on the Weierstrass model  $Y'$ .

**Remark 5.12** The type L cusps are the Weierstrass model of an intermediate fiber of type  $I_m$  for  $m \geq 0$ . Such fibers are not contracted until they have coefficient 0, and so any pseudoelliptic tree glued along a type  $I_m$  fiber will remain when lowering coefficients to any  $\epsilon > 0$ .

Finally we revisit Assumption 5.10. We first need the following characterization of intermediate models of non-log canonical Weierstrass cusps:

**Lemma 5.13** Suppose  $X = X_0 \cup_G X_1$  is a smoothable broken elliptic surface that is the union of broken elliptic surfaces  $X_i \rightarrow C_i$ , where  $C_i \cong \mathbb{P}^1$  and each  $X_i$  has a unique main component. Let  $X'$  be the result of the type II pseudoelliptic flip of the section of  $X_0$ , so that the strict transform  $X'_0$  is attached to  $X'_1$  by an intermediate fiber  $A \cup G$ . Then  $A \cup G$  is the intermediate fiber of an slc cusp if and only if  $-S_0^2 \leq 1$ , where  $S_0$  is the section of  $X_0 \rightarrow C_0$ .

**Proof** The question is local around a neighborhood of the flip. Therefore, we may assume that  $X_0$  and  $X_1$  are irreducible, so that there are no pseudoelliptic trees sprouting off either of them. On the component  $X'_1$  we have the divisor  $S_1 + aA + G$ . Note that  $G$  has coefficient 1 since it is in the double locus, and the coefficient  $a$  is given by the sum of coefficients of marked fibers on  $X'_1$ . Then the Weierstrass model of  $A \cup G$  inside  $X'_1$  has log canonical singularities if and only if  $G$  contracts onto the Weierstrass model in the log canonical model of the pair  $(X_1, S + G)$ , ie when all the coefficients

on  $X'_0$  are 0. Since the pair is smoothable, this occurs if and only if  $X'_0$  contracts to a point in the log canonical model of  $X$ , where all the coefficients on  $X'_0$  are set to 0. Since  $G$  is marked with coefficient 1 on  $X'_0$ , this occurs if only if  $X'_0$  is a minimal rational elliptic surface by [6, Proposition 7.4], which holds if and only if  $-S_0^2 \leq 1$  (where the strictly less than 1 case happens if  $G$  is a twisted fiber rather than a stable fiber of  $X_0$ ).  $\square$

**Lemma 5.14** *Let  $X$  be a surface parametrized by  $\overline{\mathcal{W}}_\sigma(\frac{1}{12} + \epsilon)$  and suppose  $Y \subset X_m$  is a normal main component. Then Assumption 5.10 is satisfied for every pseudoelliptic tree attached to  $Y$ . Moreover, the fibers these pseudoelliptic trees are attached to are minimal intermediate fibers.*

**Proof** Let  $X' \rightarrow C'$  denote the twisted stable maps model of  $X \rightarrow C$ , and let  $X'_m$  and  $Y'$  denote the strict transform of  $X_m$  and  $Y$  in  $X'$ . Let  $Z$  be a pseudoelliptic glued to an intermediate fiber  $F$  of  $Y$ , and let  $Z'$  be the components of  $X'$  that map to  $Z$ . By Remark 5.11, the number of markings on  $Z$  is equal to the contribution of  $F$  to the discriminant of the Weierstrass model of  $Y$ . Since  $X_m$  is the main component, there are less than 12 markings on  $Z$ , and so the order of vanishing of the discriminant of  $F$  in  $Y$  is less than 12. It follows that the order of vanishing of the Weierstrass data in a neighborhood of this fiber satisfies  $\min\{3v(a), 2v(b)\} < 12$ , so these are minimal Kodaira types by the standard classification.  $\square$

**5.1.2  $X_m$  is irreducible** We first deal with the case where the main component  $X_m$  of a surface parametrized by  $\overline{\mathcal{W}}_\sigma(\frac{1}{12} + \epsilon)$  is irreducible.

**Proposition 5.15** *Let  $X$  be a surface parametrized by  $\overline{\mathcal{W}}_\sigma(\frac{1}{12} + \epsilon)$  such that the main component  $X_m$  is irreducible and normal. Then  $X_m$  is a minimal elliptic K3 surface with trees of pseudoelliptic surfaces of type I attached along intermediate models of  $I_n^*$ ,  $II^*$ ,  $III^*$  and  $IV^*$  fibers.*

**Proof** By Lemma 5.14, Assumption 5.10 is satisfied. Following Section 5.1.1, we saw that there are three possibilities for the Weierstrass stable replacement of the main component  $X_m$  of a surface in  $\overline{\mathcal{W}}_\sigma(\frac{1}{12} + \epsilon)$ . In case (i) we have a minimal Weierstrass elliptic K3 surface. Then since all fibers are minimal Weierstrass fibers, any pseudoelliptic surface has to be attached by the intermediate model of a minimal Weierstrass fiber. These are exactly the intermediate models of type  $I_n^*$ ,  $II$ ,  $III$ ,  $IV$ ,  $II^*$ ,



III\* and IV\*, since type  $I_n$  Weierstrass fibers do not have intermediate models. By Corollary 5.3, pseudoelliptics sprouting off of II, III and IV fibers have contracted onto the Weierstrass model. We now rule out cases (ii) and (iii) of Section 5.1.1.

In case (ii), the Weierstrass model of the main component is a rational elliptic surface with exactly one type L cusp. In this case, there must be a type I pseudoelliptic tree  $Z$  in  $X$  attached to  $X_m$  along an intermediate model of an L cusp, and by Remark 5.11, there are 12 marked pseudofibers on  $Z$ . Let  $X_1 \rightarrow C_1$  be a twisted stable maps model that maps to  $X$  in  $\overline{\mathcal{W}}_\sigma(\frac{1}{12} + \epsilon)$ . We may write  $X_1 = Y_1 \sqcup_{I_n} Z_1$ , where

- (i)  $Z_1$  is a broken elliptic fibration that dominates the pseudoelliptic tree  $Z$ ,
- (ii)  $Y_1$  is a broken elliptic fibration that dominates  $X \setminus Z$ ,
- (iii) the component of  $Y_1$  supporting the fiber  $Y_1 \cap Z_1 = I_n$  is birational to  $X_m$ , and
- (iv) the  $Y_1 \cap Z_1 = I_n$  fiber becomes the intermediate fiber on  $X_m$  after  $Z_1$  undergoes a type II transformation into the pseudoelliptic tree  $Z$ .

Then 12 of the marked fibers of  $X_1 \rightarrow C_1$  must lie on  $Z_1$  and the other 12 on  $Y_1$ . In particular there is a node of  $C_1$ , such that if we separate  $C_1$  along that node we obtain two trees of rational curves each with 12 marked points. However, this means the stable replacement of  $C_1$  inside the Hassett space  $\overline{\mathcal{M}}_{0,\mathcal{A}}$ , for  $\mathcal{A} = (a, \dots, a)$  with  $a = \frac{1}{12} + \epsilon$ , is a nodal union of two components, contradicting that  $X$  has only one main component.

In case (iii), the Weierstrass model of  $X_m$  is a trivial surface with exactly two type L cusps and all other fibers stable. There must be type I pseudoelliptic trees attached along each of these L cusp fibers in  $X_m$ , and no other pseudoelliptic trees attached to  $X_m$ , as every other fiber of its Weierstrass model is stable. As in the previous analysis, let  $X_1 \rightarrow C_1$  be a twisted stable maps surface whose image in  $\overline{\mathcal{W}}_\sigma(\frac{1}{12} + \epsilon)$  is  $X$ , and let  $X'$  be the component of  $X_1$  that dominates  $X_m$ . Then  $X'$  is attached to exactly two other components of  $X_1$ , so by stability it must have at least one marked point on it. Since  $X_1 \rightarrow C_1$  is the twisted stable maps model, all the marked fibers have  $j$ -invariant  $\infty$ , and so since  $X'$  is isotrivial, it must be nonnormal, a contradiction.  $\square$

Next we consider the irreducible, but nonnormal main component case:

**Theorem 5.16** *Let  $X$  be a surface parametrized by  $\overline{\mathcal{W}}_\sigma(\frac{1}{12} + \epsilon)$  with an irreducible nonnormal main component  $X_m$ . Then one of the following holds:*

- (a)  $X_m$  is an isotrivial  $j = \infty$  fibration with  $4N_1$  minimal Weierstrass fibers.

- (b)  $X_m$  is an isotrivial  $j = \infty$  fibration with  $2N_1$  minimal Weierstrass fibers, as well as an intermediate  $N_2$  fiber which must have a tree of pseudoelliptic surfaces attached to it along a type  $I_n$  pseudofiber.
- (c)  $X_m$  is an isotrivial  $j = \infty$  fibration with  $2N_2$  intermediate fibers, each of which has a tree of pseudoelliptic surfaces attached to it by an  $I_n$  fiber.
- (d)  $X_m$  is an isotrivial  $j = \infty$  fibration with a minimal Weierstrass  $N_1$  fiber, as well as an intermediate  $N_3$  fiber which has a tree of pseudoelliptic surfaces attached to it by an  $I_n^*$  fiber.
- (e)  $X_m$  is an isotrivial  $j = \infty$  fibration with a single intermediate  $N_4$  fiber which has a tree of pseudoelliptic surfaces attached to it by an  $I_n$  fiber.

Moreover, if we denote by  $l$  the number of marked  $N_0$  fibers on  $X_m$ , then

(a)	(b)	(c)	(d)	(e)
$4 \leq l \leq 16$	$3 \leq l \leq 17$	$2 \leq l \leq 18$	$8 \leq l \leq 18$	$13 \leq l \leq 19$

**Proof** Suppose that Assumption 5.10 is satisfied. By Section 5.1.1, the Weierstrass model of the main component must be an slc isotrivial  $j = \infty$  Weierstrass fibration with  $\deg \mathcal{L} = 2$ , which are classified by Proposition 4.13. The lct of a type  $N_2$  fiber is 0, so these do not contract to Weierstrass models, and any attached pseudoelliptic trees do not contract for nonzero weight.

In case (c), the stability condition on the twisted stable maps limit implies that there must be at least one marked  $N_0$  fiber to give that rational component of the base curve at least three special points.

The types of pseudofibers that are attached to intermediate  $N_1$  and  $N_2$  fibers must have  $j$ -invariant  $\infty$ , so they are either type  $I_n$  or  $I_n^*$ , respectively. The twisted model of an  $N_1$  fiber is a nonreduced rational curve, and so must have a stabilizer at the corresponding point of the twisted stable map. Therefore, it must be attached to an  $I_n^*$  fiber, which also has a nontrivial stabilizer at the corresponding point of the twisted stable map. Similarly, the twisted model of an  $N_2$  fiber is a nodal curve so it has no stabilizer, and therefore must be attached to an  $I_n$  fiber.

If Assumption 5.10 is not satisfied, then by Lemma 5.13 we must have a K3 component  $Y$  attached to  $X_m$  along a fiber  $F$  such that  $Y$  is not the main component. This only happens if  $Y$  has less than 12 singular fibers counted with multiplicity away from the fiber along which  $Y$  is attached to  $X_m$ . In that case  $F$  is a fiber of  $Y$  with discriminant

at least 13, so  $F$  is either an  $I_n$  fiber for  $n \geq 13$  or an  $I_n^*$  for  $n \geq 7$ . Consider a generic family of  $24I_1$  surfaces degenerating to this surface as in Section 5.1.1.

In the first case, we have that  $n$  type  $I_1$  fibers collide to sprout out a trivial component with  $n$  markings, which becomes the main component when  $Y$  flips into a pseudoelliptic. Since  $X_m$  has only  $N_0$  fibers away from where  $Y$  is attached and the degree of  $\mathcal{L}$  must be 2, the attaching fiber is  $N_4$  by Proposition 3.20. This gives us (e). In the second case, let us denote by  $Y'$  and  $X'_m$  the strict transforms of  $Y$  and  $X_m$  in the twisted stable maps replacement of the limit of the family. Then  $Y'$  and  $X'_m$  are glued along twisted  $I_n^*/N_1$  fibers since the order of the stabilizer is 2. Then the base curve of the  $X'_m$  component must have at least one more point with a stabilizer since any finite cover of  $\mathbb{P}^1$  is ramified in at least two points. On the other hand, the stabilizer of any  $j$ -invariant  $\infty$ -curve is  $\mu_2$  so these other points have to have stabilizers of order 2. Now when the component  $Y'$  flips into the pseudoelliptic surface  $Y$ , the twisted fiber on  $X'_m$  to which it is attached must flip into a *non-semi-log canonical* intermediate fiber since Assumption 5.10 fails. Thus it must be an  $N_k$  fiber for  $k \geq 3$ . The other twisted fibers on  $X'_m$  must flip into intermediate models of  $N_k$  fibers for  $k \geq 1$  since the  $N_0$  fiber has no stabilizers. Since the degree of  $\mathcal{L}$  for the main component  $X_m$  must be 2, by Proposition 3.20, the fiber along which  $Y$  is attached must be  $N_3$ , and the only other nonstable fiber is a single  $N_1$ . This gives us case (d).

To obtain the number of markings, we may apply Proposition 4.15 to see that each  $N_k$  fiber is marked with multiplicity at least  $k + 1$ . This gives an upper bound on  $n$ . For the lower bound, we look at the largest number of marked  $I_1$  fibers that can appear on a component attached to the  $N_k$  fiber. For an  $N_1$  fiber this is five markings on a  $5I_1I_1^*$  rational, for  $N_2$  this is 11 markings on a  $12I_1$  (attached along one of the  $I_1$  fibers), for  $N_3$  this is 11 markings on an  $11I_1I_7^*$  elliptic K3, and for  $N_4$  this is 11 markings on a  $12I_1I_{13}$  elliptic K3. Here we have used that  $X_m$  is the main component so all the other components must have undergone pseudoelliptic flips at a wall above  $\frac{1}{12} + \epsilon$ . Finally, each  $N_1$  fiber is Weierstrass since there are at most five markings on the component attached to it, and so by Lemma 5.4, these components contract to a point at a  $W_{III}$  wall above  $\frac{1}{12} + \epsilon$ . □

**Remark 5.17** Each of the main components in Theorem 5.16 that have only intermediate models of semi-log canonical cusps (cases (a), (b) and (c)) are  $j = \infty$  limits of normal isotrivial elliptic surfaces. The  $4N_1$  surfaces are limits of  $4I_0^*$  isotrivial fibrations. Indeed, the locus in the moduli space of such surfaces is birational to  $\mathbb{P}^1 \times \mathbb{P}^1$ , where the

first coordinate parametrizes the  $j$ -invariant of the fibration and the second coordinate parametrizes the configuration of the  $4I_0^*$  (or  $4N_1$ ) singular fibers. Similarly the  $2N_1N_2$  surface is the limit of the isotrivial  $2I_0^*L$  surface and there is a rational curve of these in the moduli space. Finally the  $2N_2$  surface is the limit of isotrivial  $2L$  Weierstrass fibrations, but this family of  $2L$  surfaces does *not* actually appear on this component of the moduli space as we describe below.

Note that in each of these cases, when the surface is isotrivial with  $j \neq \infty$ , all the markings must be concentrated on the special fibers. Indeed by Remark 5.11, there must be six markings concentrated at an  $I_0^*$  fiber and 12 concentrated at a type  $L$  fiber. Therefore the isotrivial  $j = \infty$  surface pairs that are limits of Weierstrass models as in the above paragraph must have six markings concentrated at each  $N_1$  fiber and 12 markings concentrated at each  $N_2$  fiber. In particular, they *cannot* have any marked  $N_0$  fibers. Therefore, not all surface pairs with isotrivial  $j = \infty$  main components are in the limit of the above locus of normal Weierstrass fibrations. In particular, since the type  $2N_2$  fibrations must have at least one marked  $N_0$  fiber by stability for twisted stable maps, we see that the  $2L$  family limiting to  $2N_2$  does not appear.

Finally we address the question of existence of each of the limits described above.

**Proposition 5.18** *Each of the cases described by Proposition 5.15 and Theorem 5.16 occurs in  $\overline{\mathcal{W}}_\sigma(\frac{1}{12} + \epsilon)$ .*

**Proof** We may take the Weierstrass model of the described main component. In each case it has a Weierstrass equation with  $A$  and  $B$  of degree 8 and 12, respectively. Since the space of Weierstrass equations is irreducible, there exists a family of  $24I_1$  elliptic K3 surfaces with this Weierstrass limit. By taking the stable replacement in  $\overline{\mathcal{W}}_\sigma(\frac{1}{12} + \epsilon)$  we must obtain stable limits as described.  $\square$

**5.1.3  $X_m$  is reducible** Now we classify the broken elliptic surfaces in  $\overline{\mathcal{W}}_\sigma(\frac{1}{12} + \epsilon)$  where  $X_m$  is the union of two irreducible surfaces.

**Theorem 5.19** *Let  $X$  be a surface parametrized by  $\overline{\mathcal{W}}_\sigma(\frac{1}{12} + \epsilon)$  with reducible main component  $X_m = Y_0 \cup Y_1$ . Then one of the following holds:*

- (i) *The  $Y_i$  are rational elliptic surfaces glued along an  $I_0$  fiber. They are minimal Weierstrass surfaces away from possible intermediate type  $II^*$ ,  $III^*$  and  $IV^*$  fibers along which type I pseudoelliptic trees are attached.*

- (ii)  $Y_0$  is an elliptic K3 surface,  $Y_1$  is a trivial  $j$ -invariant  $\infty$  surface, and they are glued along  $I_{12}/N_0$  fibers. There are 12 marked  $N_0$  fibers on  $Y_1$ , and  $Y_0$  has minimal Weierstrass fibers or minimal intermediate type  $II^*$ ,  $III^*$  or  $IV^*$  fibers where type I pseudoelliptic trees are attached.
- (iii)  $Y_0$  is an elliptic K3 with an  $I_6^*$  fiber,  $Y_1$  is a  $2N_1$  isotrivial  $j$ -invariant  $\infty$  surface, and they are glued along twisted  $I_6^*/N_1$  fibers. Away from the  $I_6^*$  fiber,  $Y_0$  has minimal Weierstrass fibers or minimal intermediate type  $II^*$ ,  $III^*$  and  $IV^*$  fibers where type I pseudoelliptic trees are attached. There are  $7 \leq l \leq 10$  marked  $N_0$  fibers on  $Y_1$ .
- (iv) The  $Y_i$  are isotrivial  $j$ -invariant  $\infty$  surfaces glued along  $N_0$  fibers. Each surface has a single intermediate  $N_2$  fiber with a type I pseudoelliptic tree attached. There are  $1 \leq l_i \leq 9$  marked  $N_0$  fibers on  $Y_i$ .
- (v) The  $Y_i$  are isotrivial  $j$ -invariant  $\infty$  surfaces glued along  $N_0$  fibers. Each surface has two minimal Weierstrass  $N_1$  fibers. There are  $2 \leq l_i \leq 8$  marked  $N_0$  fibers on  $Y_i$ .
- (vi) The  $Y_i$  are isotrivial  $j$ -invariant  $\infty$  surfaces glued along  $N_0$  fibers.  $Y_0$  has two minimal Weierstrass  $N_1$  fibers and  $Y_1$  has one intermediate  $N_2$  fiber with a type I pseudoelliptic tree attached. There are  $2 \leq l_0 \leq 8$  marked  $N_0$  fibers on  $Y_0$  and  $1 \leq l_1 \leq 9$  marked  $N_0$  fibers on  $Y_1$ .

**Proof** We will proceed by taking the Weierstrass limit of the main component and using the classification in Section 5.1.1 to determine what can be attached as the other main component.

First suppose that Assumption 5.10 does not hold for the fiber along which the  $Y_i$  are glued, so that after performing a pseudoelliptic flip of  $Y_0$ , the fiber on  $Y_1$  is not the intermediate model of a semi-log canonical Weierstrass cusp. Then as in the proof of Theorem 5.16,  $Y_0$  is a K3 component and  $Y_1$  is an isotrivial  $j$ -invariant  $\infty$  surface. Furthermore, they are either glued along twisted  $I_n/N_0$  or  $I_n^*/N_1$  fibers. Since they are the two main components, they must each have 12 markings, so we conclude that  $n = 12$  in the first case and  $n = 6$  in the second case. Furthermore, as in the proof of Theorem 5.16, in the  $I_n^*/N_1$  case  $Y_1$  must have another  $N_1$  fiber. This gives us cases (ii) and (iii), respectively.

From now on we can suppose that Assumption 5.10 holds. Let us fix some notation. Denote the Weierstrass limit of the  $Y_i$  by  $Y_i^0$ , which must be one of the surfaces listed

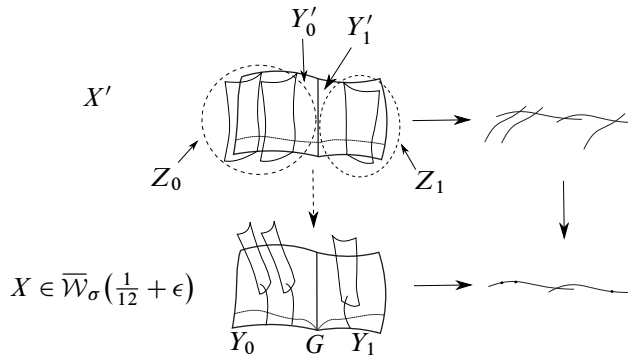

Figure 3: The circled component  $Z_i$  represents the union of  $Y'_i$  along with the pseudoelliptic trees emanating from  $Y'_i$ . The entire  $Z_i$  component dominates  $Y_i$ , and the  $Y'_i$  component contains the pseudoelliptics.

in Section 5.1.1 if it is normal, or Proposition 4.13 if it is isotrivial  $j$ -invariant  $\infty$ . We will denote by  $X^1 \rightarrow C^1$  a twisted stable maps model of the surface  $X \rightarrow C$  in  $\overline{\mathcal{W}}_\sigma(\frac{1}{12} + \epsilon)$  and we will denote by  $Y_i^1$  the unique component of  $X^1$  dominating  $Y_i$ . Let  $Z_i^1 \subset X^1$  be the maximal connected union of connected components of  $X^1$  that contains  $Y_i^1$ . Finally we will denote by  $G$  the fiber along which  $Y_0$  and  $Y_1$  are glued, and by  $G_i$  its model in the Weierstrass limit, which is obtained by flipping one of the  $Y_i$  and contracting the transform on  $G$  on the other; see Figure 3.

Now, since  $Y_0$  and  $Y_1$  satisfy Assumption 5.10 for the fiber along which they are glued, by Lemma 5.13 we must have  $0 < -S_i^2 \leq 1$ , where  $S_i$  is the section of  $Y_i$ . Note that  $S_0^2 \neq 0$ , otherwise  $Y_0$  would be *trivial* and so the degree of the  $j$ -map on  $Z_0$  would be 0 and the degree of the  $j$ -map on  $Z_1$  would be 24, which would put us in situation (ii).

Suppose that  $Y_0$  is normal. Then, by Section 5.1.1,  $Y_0$  is a rational elliptic surface and  $G_0$  is a type L cusp. Since the twisted model of a type L cusp is a stable curve,  $G$  is an  $I_n$  fiber. On the other hand, there must be 12 markings on  $Y_0$  away from  $G$ , and so  $n = 0$  and  $G$  is in fact a smooth fiber. Since  $G$  is smooth,  $Y_1$  cannot be isotrivial  $j$ -invariant  $\infty$  so it is normal, and the same analysis applies to  $Y_1$ . Thus we obtain (i).

Next, if  $Y_0$  is not normal, then as above  $Y_1$  is also nonnormal. Now the  $Y_i$  satisfy Assumption 5.10 for the fiber  $G$ . We claim that they must also satisfy it for any pseudoelliptic trees away from  $G$ . Indeed suppose that  $Y_0$  has an intermediate fiber  $F$  not satisfying Assumption 5.10. Then by Lemma 5.13, there must be an elliptic K3 attached to it. Every fiber of  $Y_i$  is  $N_k$  for  $k \leq 2$ , and we get cases (iv), (v) and (vi) by considering the various possible  $N_k$  fibers on a surface with  $-S^2 \leq 1$ .

Since  $N_2$  fibers have 0 lct, they must be intermediate with pseudoelliptic trees attached, while pseudoelliptic trees attached to an  $N_1$  fiber undergo type  $W_{III}$  contractions at walls above  $\frac{1}{12} + \epsilon$  by Lemma 5.4 so  $N_1$  fibers are minimal Weierstrass. Finally, the number of markings is constrained by Proposition 4.15, stability, and the fact that there are two main components so there must be 12 total markings on each.  $\square$

**Proposition 5.20** *Each of the cases described in Theorem 5.19 occurs in the boundary of  $\overline{\mathcal{W}}_\sigma(\frac{1}{12} + \epsilon)$ .*

**Proof** Case (i) is the stable replacement in  $\overline{\mathcal{W}}_\sigma(\frac{1}{12} + \epsilon)$  of a Kulikov degeneration of type II. Case (ii) occurs when  $12I_1$  fibers collide to give an  $I_{12}$  fiber. Similarly, case (iii) occurs when  $12I_1$  fibers collide to form an  $I_6^*$  fiber. Case (iv) occurs when one starts with a degeneration of type (i) and takes the limit as the  $I_1$  fibers approach the double locus  $G$ . Since marked  $I_1$  fibers from both  $Y_0$  and  $Y_1$  must fall into  $G$  as the  $j$ -invariant of  $G$  must match on both sides, two isotrivial components appear such that each rational surface is attached to one of them along an  $N_0$  fiber which leads to  $N_2$  fibers when the rational surfaces undergo a flip. Similarly, case (v) occurs when you start with a surface of type (i) and degenerate the two rational components into  $2N_1$  isotrivial  $j$ -invariant  $\infty$  surfaces. Finally, for case (vi), take a degeneration as in case (i) and then further degenerate  $Y_0$  so that it is an isotrivial  $2I_0^*$  surface. Then the stable replacement of the limit as the  $j$ -invariant of the  $2I_0^*$  surface approaches  $\infty$  is case (vi).  $\square$

## 6 Surfaces in $\overline{\mathcal{W}}_\sigma(\epsilon)$ , the 24-marked space at $a = \epsilon$

In the previous section, we studied the wall crossings that occur in  $\overline{\mathcal{W}}_\sigma(a)$  as we let the weight vary from 1 to  $\frac{1}{12} + \epsilon$ , and we used this to classify the surfaces parametrized by the boundary of  $\overline{\mathcal{W}}_\sigma(a)$  for  $a = \frac{1}{12} + \epsilon$ . The goal of this section is to explicitly study the wall crossings that occur as we reduce the weight further, from  $a = \frac{1}{12} + \epsilon$  to  $a = \epsilon$  for  $0 < \epsilon \ll 1$ . As a result, we determine the surfaces parametrized by the boundary of  $\overline{\mathcal{W}}_\sigma(\epsilon)$ . The main results in this direction are Theorems 6.13 and 6.14. In Theorem 6.13 we describe the possible surfaces on the boundary, and in Theorem 6.14 we use the theory of twisted stable maps (see Section 3.2) to show that all such surfaces appear on the boundary. Finally, in Theorem 6.15, we describe a morphism from the coarse space of  $\overline{\mathcal{W}}_\sigma(\epsilon)$  to the GIT quotient  $\overline{\mathcal{W}}^G$ . These three theorems together give a proof of Theorem 1.1.

We begin with the wall at  $\frac{1}{12}$ :

**Lemma 6.1** *At  $a = \frac{1}{12}$ , there are type III contractions of rational pseudoelliptic components attached by an  $I_0^*$  fiber.*

**Proof** An  $I_0^*$  must be attached along another  $I_0^*$  by the stabilizer condition. Furthermore, an  $I_0^*$  rational surface has six other markings with multiplicity. Putting this together with the description of the walls, we get a wall at  $1/(2k) = \frac{1}{12}$  since  $\frac{1}{2}$  is the lct of  $I_0^*$ ; see (2) in Section 3.  $\square$

**Lemma 6.2** *At  $a = \frac{1}{12}$  the trivial component  $Y_1$  in case (ii) of Theorem 5.19 contracts onto the  $I_{12}$  fiber it is attached to.*

**Proof** The component of the base curve lying under  $Y_1$  contracts to a point, but since  $Y_1$  is trivial, it contracts onto a fiber.  $\square$

**Lemma 6.3** *Let  $X$  be a surface parametrized by  $\overline{W}_\sigma(\frac{1}{12} + \epsilon)$  from Theorem 5.19(iii). Then the stable replacement for coefficients  $\frac{1}{12} - \epsilon$  is an irreducible pseudoelliptic K3 surface with an  $I_6^*$  fiber.*

**Proof**  $X$  has main component  $X_m = Y_0 \cup Y_1$  consisting of an elliptic K3 with a twisted  $I_6^*$  fiber glued to an isotrivial  $j$ -invariant  $\infty$  surface along a twisted  $N_1$  fiber. Each surface has 12 markings. At coefficient  $\frac{1}{12} - \epsilon$ , both section components are contracted by an extremal contraction. We first perform the extremal contraction of the section of  $Y_1$  which results in a flip of  $Y_1$  to a pseudoelliptic surface. Then the section of  $Y_0$  contracts to form a pseudoelliptic with the pseudoelliptic model of  $Y_1$  glued along an  $I_6^*$  pseudofiber. Finally,  $Y_1$  contracts onto a point as in Lemma 6.1.  $\square$

Putting the above together with the observation that the Hassett space becomes a point at  $\frac{1}{12}$  so the base curves all contract to a point, we get:

**Theorem 6.4** *Let  $X$  be a surface parametrized by  $\overline{W}_\sigma(\frac{1}{12} - \epsilon)$ .*

- (i) *If  $X$  has a single main component, then  $X_m$  is the pseudoelliptic surface associated to an elliptic surface, as in Proposition 5.15 and Theorem 5.16, with an  $A_1$  singularity where the section contracted. Any type II, III, IV,  $N_1$  and  $I_k^*$  for  $k \leq 5$  pseudofibers of  $X_m$  are Weierstrass and any  $I_n$  fibers satisfy  $n \leq 12$ . There are pseudoelliptic trees sprouting off of intermediate type  $II^*$ ,  $III^*$ ,  $IV^*$  and  $N_k$  for  $k \geq 2$  fibers as before.*



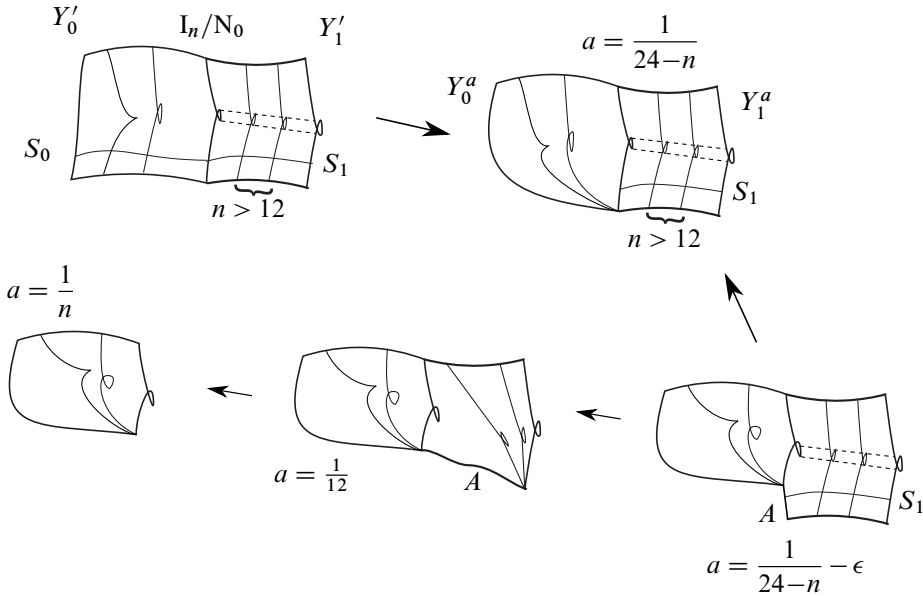

Figure 4: Illustration of Example 6.6.

- (ii) If  $X$  has two main components, then  $X_m$  is a union along a twisted pseudofiber of the surfaces appearing in Theorem 5.19, parts (i), (iv), (v) and (vi). Any type II, III, IV,  $N_1$  and  $I_k^*$  for  $k \leq 5$  pseudofibers are Weierstrass. There are pseudoelliptic trees sprouting off of intermediate  $II^*$ ,  $III^*$ ,  $IV^*$  and  $N_2$  fibers as before.

**Lemma 6.5** There are type III walls at  $a = \frac{1}{60}$ ,  $\frac{1}{36}$  and  $\frac{1}{24}$  where rational pseudoelliptic surfaces attached along intermediate type  $II^*$ ,  $III^*$  and  $IV^*$  fibers, respectively, contract to a point.

**Proof** This follows from [8, Theorem 6.3] as well as the observation that a rational elliptic surface attached to a type  $II^*$ ,  $III^*$  or  $IV^*$  fiber must have a II, III or IV fiber, respectively, and so it has 10, 9 or 8 other marked fibers counted with multiplicity.  $\square$

Next we study some examples of the transformations that occur for small coefficients.

**Example 6.6** (Figure 4) Suppose  $X_\eta$  is a smooth elliptic K3 surface with 24 ( $I_1$ ) fibers, and suppose it appears as the general fiber of a family  $(f : \mathcal{X} \rightarrow B, \mathcal{S} + \mathcal{F}_a)$  with limit as in Theorem 5.16, case (d). In particular, this is a stable limit for  $a = \frac{1}{12} + \epsilon$  and  $\mathcal{F}$  consisting of the  $24I_1$  fibers on the generic surface  $X_\eta$ . We will compute the stable limit of this family for  $a < \frac{1}{12}$ . We will denote by  $X^a$  the  $a$ -stable special fiber of  $\mathcal{X} \rightarrow B$ .

We begin with the twisted stable maps limit  $X^1 \rightarrow C^1$ . It consists of a union  $Y_0^1 \cup Y_1^1$  where  $Y_0^1$  is an elliptic K3 and  $Y_1^1$  is a trivial  $j$ -invariant  $\infty$  surface with  $n$  marked fibers glued along an  $I_n$  fiber of  $Y_0^1$  where  $n > 12$ . At  $a = 1/(24 - n)$ , the component  $Y_0^1$  undergoes a pseudoelliptic flip to obtain the model in Theorem 5.16(d), ie  $Y_0^a$  is a pseudoelliptic K3 glued along an intermediate  $N_4$  fiber  $A^a \cup G^a$  of  $Y_1^a$ . Next, for  $a \leq \frac{1}{12}$ , the section of  $Y_1^a$  contracts onto an  $A_1$  singularity so that  $X^a$  consists of a pseudoelliptic isotrivial  $j$ -invariant  $\infty$  surface with an intermediate  $N_4$  pseudofiber and a pseudoelliptic K3 sprouting off it. To continue the MMP on this 1-parameter family and compute the stable limit for smaller  $a$ , we need to compute  $(K_{\mathcal{X}^a} + \mathcal{F}^a).A^a$  and  $(K_{\mathcal{X}^a} + \mathcal{F}^a).G^a$ . We can restrict the log canonical divisor to the component  $Y_1^a$  to obtain

$$K_{Y_1^a} + G + (24 - n)aA^a + naf,$$

where  $f$  is a pseudofiber class. Pulling back to the blowup of the section  $\mu: Y_1^b \rightarrow Y_1^a$  where  $b = \frac{1}{12} + \epsilon$ ,

$$\mu^*(K_{Y_1^a} + G + (24 - n)aA^a + naf^a) = K_{Y_1^b} + G^b + (24 - n)aA^b + naf^b + 12aS_1^b.$$

Here  $S_1^b$  is the section which is a  $(-2)$ -curve and  $f^b$  is a fiber class. Now  $A^b$  is the curve obtained by flipping the section  $S_0$  of  $Y_0^1$ . Using the local structure of the flip (see eg [33, Section 7.1]), we compute that  $(A^b)^2 = -\frac{1}{2}$ ,  $A^b.G^b = \frac{1}{2}$  and  $(G^b)^2 = -\frac{1}{2}$ . Similarly, using push-pull for the contraction  $\rho: Y_1^b \rightarrow Y_1^1$  onto the twisted model of  $Y_1^1$ , we get that  $K_{Y_1^b} = -2f^b + 2A^b$ . Putting all these together and using push-pull for  $\mu$ ,

$$\begin{aligned} (K_{Y_1^a} + G + (24 - n)aA^a + naf).A^a &= (K_{Y_1^b} + G^b + (24 - n)aA^b + naf^b + 12aS_1^b).A^b \\ &= \frac{1}{2}na - \frac{1}{2}, \end{aligned}$$

$$\begin{aligned} (K_{Y_1^a} + G + (24 - n)aA^a + naf).B^a &= (K_{Y_1^b} + G^b + (24 - n)aA^b + naf^b + 12aS_1^b).G^b \\ &= \frac{1}{2} + (24 - n) \cdot \frac{1}{2}a. \end{aligned}$$

In particular, for  $a < 1/n$ , there is an extremal contraction of the curve class of  $A^a$  in  $\mathcal{X}^a$ . On the other hand, since  $(A^b)^2 = -\frac{1}{2}$  and  $\mu$  is the contraction of a  $(-2)$ -curve which intersects  $A^b$  transversely, we have  $(A^a)^2 = 0$ , so this curve class rules  $Y_1^b$  over  $G^b$  and the extremal contraction for  $a < 1/n$  contracts  $X^a$  onto  $Y_0^a$ , the pseudoelliptic K3.

**Remark 6.7** In the above example,  $n \leq 19$ , by eg [44].

**Example 6.8** (Figure 5) Suppose  $X_\eta$  as above is a smooth elliptic K3 surface with 24  $(I_1)$  fibers, which appears as the general fiber of a family  $(f: \mathcal{X} \rightarrow \mathcal{B}, \mathcal{S} + \mathcal{F}_a)$  with limit as in Theorem 5.16(e). We compute the stable limit for small  $a$  as above and we keep the same notation.

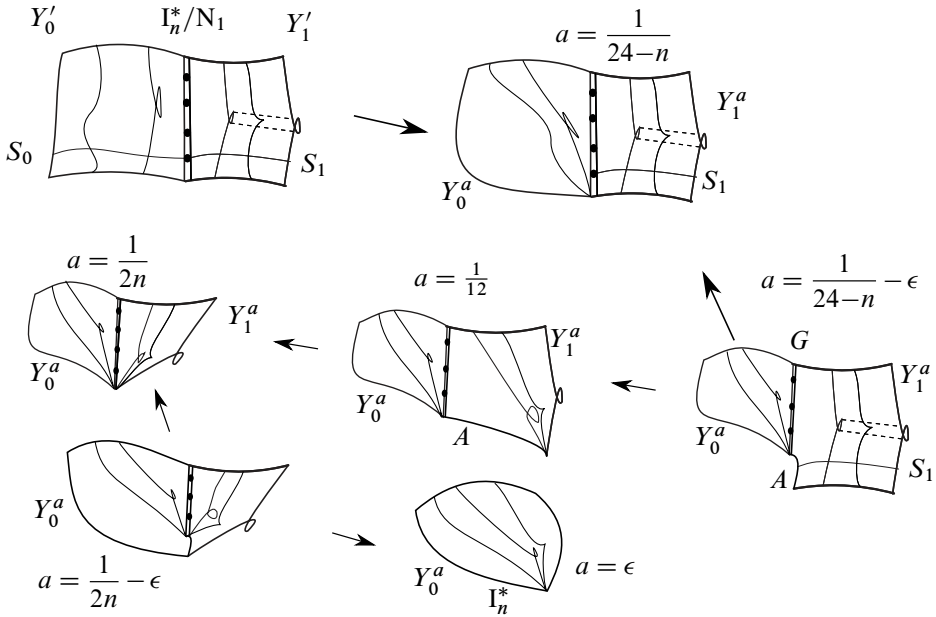

Figure 5: Illustration of Example 6.8.

The twisted stable maps limit  $X^1 \rightarrow C^1$  consists of a union  $Y_0^1 \cup Y_1^1$  where  $Y_0^1$  is an elliptic K3 and  $Y_1^1$  is a  $2N_1$  isotrivial  $j$ -invariant  $\infty$  surface. They are glued along twisted  $I_n^*/N_1$  fibers with  $n > 6$ . At  $a = 1/(18 - n)$ , the component  $Y_0^1$  undergoes a pseudoelliptic flip to obtain the model in Theorem 5.16, case (e), ie  $Y_0^a$  is a pseudoelliptic K3 with a twisted  $I_n^*$  pseudofiber glued along an intermediate  $N_3$  fiber  $A^a \cup G^a$  of  $Y_1^a$ . As above, the section of  $Y_1^a$  contracts onto an  $A_1$  singularity for  $a \leq \frac{1}{12}$  so that  $X^a$  consists of a pseudoelliptic isotrivial  $j$ -invariant  $\infty$  surface with an intermediate  $N_3$  pseudofiber and a pseudoelliptic K3 sprouting off it. The  $N_1$  pseudofiber of  $Y_1^a$  may have a pseudoelliptic tree sprouting off of it, but it exhibits a type  $W_{III}$  contraction onto the Weierstrass model of the  $N_1$  fiber by Lemma 5.4.

Restricting the log canonical divisor to the component  $Y_1^a$ , we obtain

$$K_{Y_1^a} + G + (18 - n)aA^a + (6 + n)af$$

where  $f$  is a pseudofiber class. Pulling back to the blowup of the section  $\mu: Y_1^b \rightarrow Y_1^a$  where  $b = \frac{1}{12} + \epsilon$ ,

$$\begin{aligned} \mu^*(K_{Y_1^a} + G + (18 - n)aA^a + (6 + n)af^a) \\ = K_{Y_1^b} + G^b + (18 - n)aA^b + (6 + n)af^b + 12aS_1^b. \end{aligned}$$

As above,  $A^b$  is the curve obtained by flipping the section  $S_0$  of  $Y_0^1$  which is a rational curve with self intersection  $-\frac{3}{2}$  since  $Y_0^1$  has a twisted  $I_n^*$  fiber. Thus we can compute that  $(A^b)^2 = -\frac{2}{3}$ ,  $A^b \cdot G^b = \frac{1}{3}$  and  $(G^b)^2 = -\frac{1}{6}$ . Using push-pull for the contraction  $\rho: Y_1^b \rightarrow Y_1^1$  onto the model of  $Y_1^1$  with a twisted  $N_1$  fiber for the double locus and a Weierstrass  $N_1$  fiber for the other  $N_1$ , we get that  $K_{Y_1^b} = -f^b + A^b$ . Putting all these together and using push-pull for  $\mu$ ,

$$\begin{aligned} (K_{Y_1^a} + G + (18-n)aA^a + (6+n)af).A^a \\ &= (K_{Y_1^b} + G^b + (18-n)aA^b + (6+n)af^b + 12aS_1^b).A^b \\ &= \frac{2}{3}an - \frac{1}{3}, \\ (K_{Y_1^a} + G + (18-n)aA^a + (6+n)af).B^a \\ &= (K_{Y_1^b} + G^b + (18-n)aA^b + (6+n)af^b + 12aS_1^b).G^b \\ &= \frac{1}{6} + (18-n) \cdot \frac{1}{3}a. \end{aligned}$$

For  $a < 1/(2n)$ , there is an extremal contraction of the curve class of  $A^a$  in  $\mathcal{X}^a$ . On the other hand, since  $(A^b)^2 = -\frac{2}{3}$  and  $\mu$  is the contraction of a  $(-2)$ -curve which intersects  $A^b$  transversely, we have  $(A^a)^2 = -\frac{1}{6}$  so this curve class is rigid and therefore undergoes a flip. After the flip, the strict transform  $Y_1^a$  for  $a < 1/(2n)$  is now a pseudoelliptic attached along an intermediate pseudofiber of  $Y_0^a$ . By Lemma 5.13, the flipped pseudoelliptic contracts and goes through a type  $W_{III}$  pseudoelliptic flip for some small  $a = \epsilon > 0$ , giving the stable limit as the minimal Weierstrass pseudoelliptic of  $Y_0^a$ .

**Remark 6.9** By eg [44], the maximum  $n$  such that there exists an elliptic K3 with an  $I_n^*$  is 14 and so the above phenomena occur for  $6 < n \leq 14$ .

Combining the above examples gives:

**Proposition 6.10** (i) *There are type III walls at  $1/k$  for  $13 \leq k \leq 19$  where the isotrivial  $j$ -invariant  $\infty$  main component of the surfaces from Theorem 5.16, case (d), contract as a ruled surface onto the  $I_n$  fiber of the pseudoelliptic K3 sprouting off of it.*

(ii) *There are type III walls at  $1/(2n)$  for  $6 < n \leq 14$ , where the isotrivial  $j$ -invariant  $\infty$  main component as in Theorem 5.16, case (e), goes through a flip to become a pseudoelliptic attached to an intermediate model of the  $I_n^*$  on the K3 component. At some smaller  $a = \epsilon > 0$ , this pseudoelliptic contracts onto the Weierstrass model of the  $I_n^*$  fiber.*

**Corollary 6.11** *The stable replacements in  $\overline{\mathcal{W}}_\sigma(\epsilon)$  of the two main component surfaces of  $\overline{\mathcal{W}}_\sigma(\frac{1}{12} + \epsilon)$  from Theorem 5.19(d)–(e) are pseudoelliptic K3s with Weierstrass  $I_n$  and  $I_n^*$  fibers, respectively.*

**Proposition 6.12** *If  $X$  is a surface parametrized by  $\overline{\mathcal{W}}_\sigma(\epsilon)$  then  $\omega_X \cong \mathcal{O}_X$ .*

**Proof** If  $X$  is irreducible then the result is clear, since  $X$  is the contraction of the section, a  $(-2)$ -curve, on a K3 type Weierstrass fibration.

Therefore, suppose  $X$  consists of multiple components. Let  $p: \mathcal{X} \rightarrow D$  be a 1-parameter family over the spectrum of a DVR with generic fiber a  $24I_1$  elliptic K3 and central fiber  $X$ . Now there is a sequence of pseudoelliptic flips producing a model  $p': \mathcal{X}' \rightarrow D$ , where the sections of  $X$  are blown back up so that the components of central fiber  $X'$  of  $p'$  are all elliptically fibered and glued along twisted fibers (for example, these flips occur as part of the MMP when decreasing the coefficient on the section of the twisted model, or equivalently,  $X'$  is the model parametrized by the Brunyate/Inchiostro moduli space). Then  $X' = X_0 \cup_{F_0} X_1 \cup_{F_1} \dots \cup_{F_{n-1}} X_n \cup_{F_n} X_{n+1}$ , where  $X_0$  and  $X_{n+1}$  are rational elliptic surfaces and  $X_1, \dots, X_n$  are trivial  $j$ -invariant  $\infty$  fibrations.

Then  $K_{X'}|_{X_0} = K_{X_0} + F_0$ ,  $K_{X'}|_{X_{n+1}} = K_{X_{n+1}} + F_n$  and  $K_X|_{X_i} = K_{X_i} + F_{i-1} + F_i$  for  $i = 1, \dots, n$ , which are all 0 by the canonical bundle formula since  $X_0$  and  $X_{n+1}$  (resp.  $X_1, \dots, X_n$ ) satisfy  $\text{deg } \mathcal{L} = 1$  (resp.  $\text{deg } \mathcal{L} = 0$ ). Thus  $K_{X'}$  is numerically trivial, that is,  $K_{X'} \equiv 0$ .

We proceed in two steps. First we show that  $X'$  is Gorenstein and then we show that the pullback

$$(4) \quad \text{Pic}(X') \rightarrow \bigoplus_{i=0}^{n+1} \text{Pic}(X_i)$$

is injective. For the first claim, note that away from the gluing fibers  $F_i$ , the surface  $X'$  is a minimal Weierstrass fibration. From the classification of surfaces (see Corollary 6.11), the components  $X_i$  are glued along  $I_n$  type fibers, and so in a neighborhood of  $F_i$  the surface corresponds to a map from a nonstacky nodal curve into  $\overline{\mathcal{M}}_{1,1}$ . In particular, in a neighborhood of  $F_i$ , the elliptic fibration  $X' \rightarrow C$  is a flat family of nodal curves over a nodal curve. In either case,  $X'$  is Gorenstein.

Next, denote by  $\pi: \bigsqcup X_i \rightarrow X'$  the natural morphism. By [22, Proposition 2.6 and Remark 2.7] there is a diagram of short exact sequences of sheaves of abelian groups

on  $X'$

$$\begin{array}{ccccccc}
 1 & \longrightarrow & \mathcal{O}_{X'}^* & \xrightarrow{\alpha} & \prod_{i=0}^{n+1} \pi_* \mathcal{O}_{X_i}^* & \longrightarrow & \mathcal{N} \longrightarrow 0 \\
 & & \downarrow & & \downarrow & & \parallel \\
 1 & \longrightarrow & \mathcal{O}_{F'}^* & \xrightarrow{\beta} & \pi_* \mathcal{O}_F^* & \longrightarrow & \mathcal{N} \longrightarrow 0
 \end{array}$$

where  $F'$  is the double locus on  $X'$  and  $F$  is the double locus on  $X_i$ . As an abstract variety,  $F$  is the disjoint union of two copies of  $F'$ . By [22, Proposition 4.2], (4) is injective if and only if  $\gamma : \text{Pic}(F') \rightarrow \text{Pic}(F)$  is injective and  $\text{coker } H^0(\alpha) = \text{coker } H^0(\beta)$ . The map  $\gamma$  is simply the diagonal, so it is injective. Moreover, since  $X'$ ,  $X_i$  and  $F_i$  are all connected projective varieties, applying  $H^0$  to the above diagram gives

$$\begin{array}{ccc}
 1 & \longrightarrow & k^* \xrightarrow{H^0(\alpha)} \prod_{i=0}^{n+1} k^* \\
 & & \downarrow f_1 \qquad \qquad \downarrow f_2 \\
 1 & \longrightarrow & \prod_{i=0}^n k^* \xrightarrow{H^0(\beta)} \prod_{i=0}^n k^* \times k^*
 \end{array}$$

Here  $f_1$  and  $H^0(\alpha)$  are the diagonal maps,  $H^0(\beta)$  is the product of diagonal maps for each  $i$ , and  $f_2$  is given by  $(x_0, \dots, x_{n+1}) \mapsto (x_0, x_1, x_1, x_2, \dots, x_n, x_{n+1})$ . The cokernel of  $H^0(\alpha)$  can be identified with  $\prod_{i=1}^{n+1} k^*$  by the map

$$(x_0, \dots, x_{n+1}) \mapsto \left( \frac{x_1}{x_0}, \dots, \frac{x_{n+1}}{x_0} \right).$$

Similarly, the cokernel of  $H^0(\beta)$  can be identified with  $\prod_{i=0}^n k^*$  by the map

$$(a_0, b_0, a_1, b_1, \dots, a_n, b_n) \mapsto \left( \frac{b_0}{a_0}, \frac{b_1}{a_1}, \dots, \frac{b_n}{a_n} \right).$$

Therefore the induced map on cokernels is given by

$$(x_1, \dots, x_{n+1}) \mapsto \left( x_1, \frac{x_2}{x_1}, \dots, \frac{x_{n+1}}{x_n} \right),$$

which is an isomorphism. Thus we conclude that (4) is an injection.

This means that  $X'$  is Gorenstein and  $\omega_{X'}$  pulls back to the trivial line bundle under (4), so  $\omega_{X'} \cong \mathcal{O}_{X'}$ . It follows that  $\omega_{\mathcal{X}'/\mathcal{D}} \cong \mathcal{O}_{\mathcal{X}'}$ . Now  $\mathcal{X}'$  is related to  $\mathcal{X}$  by a sequence of log flips. Since these flips always contract  $K$ -trivial curves, we conclude from the cone theorem (see eg [30, Theorem 3.7(4)]) that the canonical line bundle is preserved, so  $\omega_{\mathcal{X}} \cong \mathcal{O}_{\mathcal{X}}$  and so  $\omega_X \cong \mathcal{O}_X$ . □

Putting all of this together, we have a classification of the boundary components of  $\overline{\mathcal{W}}_\sigma(\epsilon)$ ; see Section 7 for an alternative description.

**Theorem 6.13** *The surfaces in  $\overline{\mathcal{W}}_\sigma(\epsilon)$  are*

- (A) *an irreducible pseudoelliptic K3 with the section contracted to an  $A_1$  singularity and minimal Weierstrass pseudofibers,*
- (B) *an irreducible isotrivial  $j = \infty$  pseudoelliptic with  $4N_1$  Weierstrass fibers,*
- (C) *an isotrivial  $j = \infty$  fibration with  $2N_1$  Weierstrass fibers and an  $N_2$  intermediate fiber with a tree of pseudoelliptics sprouting off of it,*
- (D) *an isotrivial  $j = \infty$  fibration with  $2N_2$  intermediate fibers each sprouting a tree of pseudoelliptics,*
- (E) *a union of irreducible pseudoelliptic rational surfaces along an  $I_0$  fiber,*
- (F) *a union of isotrivial  $j = \infty$  pseudoelliptic surfaces with a single intermediate  $N_2$  fiber sprouting a pseudoelliptic tree on each, glued along an  $N_0$  fiber,*
- (G) *a union of irreducible isotrivial  $j = \infty$  surfaces each with  $2N_1$  Weierstrass fibers glued along an  $N_0$  fiber,*
- (H) *a union of an irreducible isotrivial  $j = \infty$  surface with  $2N_1$  Weierstrass fibers and an isotrivial  $j = \infty$  surface with a single  $N_2$  fiber sprouting a pseudoelliptic tree, glued along an  $N_0$  fiber.*

Furthermore, every surface  $X$  satisfies  $\omega_X \cong \mathcal{O}_X$  and  $H^1(X, \mathcal{O}_X) = 0$ . Finally, the number of marked  $N_0$  fibers are as in Theorems 5.16 and 5.19.

Now we show that each surface actually appears on the boundary, using the full smoothability results of Section 3.2.

**Theorem 6.14** *Every slc surface pair in Theorem 6.13 appears in the boundary of  $\overline{\mathcal{W}}_\sigma(\epsilon)$ .*

**Proof** Given any surface satisfying the conditions of Theorem 6.13, we can construct a twisted surface whose stable replacement is the surface obtained by flipping the pseudoelliptic components into elliptically fibered ones as in the previous section, replacing each cuspidal fiber by a twisted fiber, and attaching a component with dual monodromy satisfying the conditions of Propositions 3.23 and 3.26 to each of these twisted fibers. By full smoothability (Theorems 3.24 and 3.28), this twisted model is the limit of a family of  $24I_1$  elliptic K3 surfaces with singular fibers marked, and its stable replacement must be the initial surface as computed in the previous two sections.  $\square$

We conclude this section by discussing the connection between  $\overline{\mathcal{W}}_\sigma(\epsilon)$  and the GIT quotient  $\overline{\mathcal{W}}^G$ .

**Theorem 6.15** (connection with GIT/SBB) *If  $\overline{\mathcal{W}}_\sigma(\epsilon)$  denotes the coarse space of  $\overline{\mathcal{W}}_\sigma(\epsilon)$  then there is a morphism  $\overline{\mathcal{W}}_\sigma(\epsilon) \rightarrow \overline{\mathcal{W}}^G \cong \overline{\mathcal{W}}^*$  with the following structure:*

- (i) *The locus of surfaces of type (A) maps isomorphically onto  $\mathcal{W}_s^G$ .*
- (ii) *The locus of surfaces of type (B) maps as a generic  $\mathbb{P}^{12}$ -bundle onto  $\overline{\mathcal{W}}_{\text{slc},o}^G$  by forgetting the marked fibers. The closure of this locus in  $\overline{\mathcal{W}}_\sigma(\epsilon)$  parametrizes the unique surface of type (G) along with a choice of marked fibers, and this locus all maps onto  $\overline{\mathcal{W}}_{\text{slc}}^G \cap \overline{\mathcal{W}}_L^G$ .*
- (iii) *The locus of surfaces of type (E) maps onto  $\overline{\mathcal{W}}_L^G$  by taking the  $j$ -invariant of the  $I_0$  fiber along which the two components are glued.*
- (iv) *The surfaces of type (C), (D), (F) and (H) all get mapped onto the point  $\overline{\mathcal{W}}_{\text{slc}}^G \cap \overline{\mathcal{W}}_L^G$ .*

**Proof** By Theorem 6.13, we have a classification of surfaces in  $\overline{\mathcal{W}}_\sigma(\epsilon)$ . Each of the irreducible surfaces mentioned in the theorem is also parametrized by  $\overline{\mathcal{W}}^*$ , yielding a rational map  $\overline{\mathcal{W}}_\sigma(\epsilon) \rightarrow \overline{\mathcal{W}}^G$  defined on a dense open subset. Now one can easily check that the limit in  $\overline{\mathcal{W}}^G$  of a Weierstrass family limiting to a surface of type (B) (resp. type (C), (D), (G), (F) or (H)) is the  $j$ -invariant of the  $L$  (resp.  $N_2$ ) fiber in  $\overline{\mathcal{W}}_L^G$ . This depends only the central fiber of the family, not the family itself, so the morphism extends uniquely by normality after applying [18, Theorem 7.3].  $\square$

## 7 Explicit description of the boundary of $\overline{\mathcal{W}}_\sigma(\epsilon)$

In the previous section, specifically Theorems 6.13 and 6.14, we gave an explicit description of the surfaces parametrized by the boundary of  $\overline{\mathcal{W}}_\sigma(\epsilon)$ . The goal of this section is to enumerate the resulting boundary strata of  $\overline{\mathcal{W}}_\sigma(\epsilon)$  in a combinatorial way, akin to Kulikov models; see Proposition 7.2 for the analogue of *type II* degenerations, and Theorems 7.5, 7.7 and 7.9 for the analogues of the *type III* degenerations.

Before starting, we define  $R_n$  to be the space parametrizing pairs  $(X, S + F)$ , where  $X$  is a minimal Weierstrass rational elliptic surface,  $S$  is a section, and  $F$  is a fiber of type  $I_n$ . Note that  $n \leq 9$ . The following is well known:



**Lemma 7.1** [24, Section 3.3]  $R_n$  is a  $(9-n)$ -dimensional affine variety which is irreducible for  $n \neq 8$ , while  $R_8$  has two components.

Using these spaces, we will explicitly describe the boundary of  $\overline{\mathcal{W}}_\sigma(\epsilon)$ . To do so, we use the notation of Kulikov models (models of type II and III).

### 7.1 Type II degenerations

**Proposition 7.2** *There are two type II strata:*

- (i) *The first is a dimension-17 stratum  $W_{II}$  isomorphic to a quotient of the fiber product  $R_0 \times_j R_0$ , namely the self fiber product of the  $j$ -map  $j : R_0 \rightarrow \mathbb{A}^1$ . A point parametrizes two rational elliptic surfaces with a marked  $I_0$  fiber of the same  $j$ -invariant glued along this fiber, and the quotient comes from swapping the two surfaces; see Theorem 6.13(E).*
- (ii) *The second is a dimension-17 stratum  $W_{II}^\infty \cong \text{Sym}^{16}(\mathbb{P}^1) \times \mathbb{A}^1$  where  $\mathbb{A}^1$  is the  $j$ -line. The  $j$ -line parametrizes the  $4N_1$  isotrivial  $j$ -invariant  $\infty$  component, and  $\text{Sym}^{16}(\mathbb{P}^1)$  parametrizes the  $m$  markings on this surface other than the  $N_1$  fibers counted with multiplicity; see Theorem 6.13(B).*

### 7.2 Type III degenerations

The first step is to “unflip” the pseudoelliptic components in Theorem 6.13. After, we can describe each surface as a chain  $X_0 \cup \dots \cup X_{n+1}$ , where both  $X_0$  and  $X_{n+1}$  are Weierstrass fibrations of rational type ( $\text{deg } \mathcal{L} = 1$ ), and  $X_1, \dots, X_n$  are all isomorphic to trivial  $j$ -invariant  $\infty$  fibrations  $C \times \mathbb{P}^1$ , with  $C$  being a nodal cubic. These surfaces are all glued along nodal cubic fibers (ie either  $I_n$  or  $N_0$  fibers). Further, each  $X_i$  for  $i = 1, \dots, n$  must have *at least* one marked fiber by stability. We call the surfaces  $X_0$  and  $X_{n+1}$  the *end components* and  $X_1, \dots, X_n$  the *intermediate components*.

**Lemma 7.3** *An end component must have at least three marked fibers if it is normal, or at least four marked fibers if it is isotrivial  $j$ -invariant  $\infty$ , counted with multiplicity.*

**Proof** If an end component is an isotrivial  $j$ -invariant  $\infty$  surface, then it must be a  $2N_1$  fibration glued along an  $N_0$  fiber. Each  $N_1$  must carry at least two markings counted with multiplicity so the surface carries at least four. If it is a normal rational elliptic surface, then the number of markings is given by  $12 - n$ , where the surface is glued along an  $I_n$  fiber. Since  $n \leq 9$  for  $I_n$  fibers on a rational elliptic surface, then there are at most three markings on such a component. □

**Corollary 7.4** For the chains  $X_0 \cup \cdots \cup X_{n+1}$  in the type III locus,  $n$  is at most 18.

**Proof** As there is at least one marking on each of the intermediate components, the number of components is bounded by the number of markings not on  $X_0$  and  $X_{n+1}$ . By Lemma 7.3, there are at least six combined on these components so there are at least 18 markings to be distributed among the intermediate components.  $\square$

Now we will describe an explicit parametrization of each of the type III strata. There are three cases, depending on whether none, one or both of the end components  $X_0$  and  $X_{n+1}$  are isotrivial  $j$ -invariant  $\infty$ . We call these strata type III<sub>0</sub>, III<sub>1</sub> and III<sub>2</sub>, respectively. The type III<sub>0</sub> strata are further indexed by the fiber types I<sub>r</sub> and I<sub>s</sub> along which  $X_0$  and  $X_{n+1}$  are glued. In this case, there are  $12 - r$  and  $12 - s$  fibers marked on  $X_0$  and  $X_{n+1}$ , respectively, which gives us  $r + s$  markings remaining for the middle components  $X_1, \dots, X_n$ . Thus,  $n$  must satisfy  $1 \leq n \leq r + s$ .

Finally, for each  $n$ , we can fix a single marking on each component  $X_1, \dots, X_n$  and fix coordinates so that the components are glued along fibers at 0 and  $\infty$ , and the chosen marking is at 1. That gives us freedom to parametrize  $r + s - n$  additional markings among  $X_1, \dots, X_n$ . For each choice of partition  $\sum_{i=1}^n a_i = r + s - n$  we can consider the stratum where there are  $a_i$  markings on  $X_i$ .

**Theorem 7.5** (type III<sub>0</sub> locus) Fix data

$$1 \leq r, s \leq 9, \quad 1 \leq n \leq r + s, \quad \sum_{i=1}^n a_i = r + s - n.$$

There is a type III<sub>0</sub> stratum  $\text{III}_{0, a_1, \dots, a_n}^{r, s, n}$  of dimension  $\dim(\text{III}_{0, a_1, \dots, a_n}^{r, s, n}) = 18 - n$  with a finite parametrization by  $R_s \times \mathbb{G}_m^{a_1} \times \cdots \times \mathbb{G}_m^{a_n} \times R_r$ . Here a point of the above product determines the surface pairs  $X_0, X_{n+1}$  as well as the configuration of  $a_i$  marked fibers on  $X_1, \dots, X_n$  avoiding the double locus.

**Remark 7.6** Just to reiterate,  $R_s$  and  $R_r$  parametrize the surfaces  $X_0$  and  $X_{n+1}$ , respectively, and the  $\mathbb{G}_m^{a_i}$  parametrize the marked fibers on the  $X_i$  avoiding the double locus.

Next, we consider type III<sub>1</sub> strata where exactly one of the end surfaces, without loss of generality  $X_0$ , is an isotrivial  $j$ -invariant  $\infty$  surface of rational type. Then  $X_0$  must be the  $2N_1$  surface glued along an  $N_0$  fiber. There are two markings each on the  $N_1$  fibers

for a total of four. Then for each  $0 \leq s \leq 17$ , there is a stratum with  $17 - s$  marked  $N_0$  fibers on  $X_0$ ; see Theorem 5.16. After picking coordinates so that the  $N_1$  fibers are at 0 and 1 and the double locus is at  $\infty$ , these  $17 - s$  markings must avoid  $\infty$  and so give a factor of  $\mathbb{A}^{17-s}$  parametrizing  $X_0$ . The other end component  $X_{n+1}$  is a rational elliptic surface glued along an  $I_r$  fiber for some  $r$  and with  $12 - r$  marked fibers.

This gives  $33 - s - r$  total markings on  $X_0$  and  $X_{n+1}$ . On the other hand, there are at most 24 markings, so  $33 - s - r \leq 24$ . In the case of equality, there are no intermediate components and we have a stratum parametrized by  $\mathbb{A}^{17-s} \times R_r$ . Otherwise, we have  $1 \leq n \leq s + r - 9$  intermediate components with  $s + r - 9$  markings distributed on them. After fixing one marking on each intermediate component at coordinate 1, there are  $r + s - 9 - n$  marked fibers partitioned into  $\sum_{i=1}^n a_i = r + s - 9 - n$ . This gives a finite parametrization by  $\mathbb{A}^{17-s} \times \mathbb{G}_m^{a_1} \times \dots \times \mathbb{G}_m^{a_n} \times R_r$ .

**Theorem 7.7** (type III<sub>1</sub> locus) (i) Fix the data

$$1 \leq r \leq 9, \quad 0 \leq s \leq 17, \quad s + r = 9.$$

There is a type III<sub>1</sub> stratum III<sub>1</sub><sup>r,s</sup> of dimension  $\dim(\text{III}_1^{r,s}) = 17$  with a finite parametrization by  $\mathbb{A}^{17-s} \times R_r$ .

(ii) Fix the data

$$1 \leq r \leq 9, \quad 1 \leq s \leq 17, \quad 1 \leq n \leq s + r - 9, \quad \sum_{i=1}^n a_i = r + s - 9 - n.$$

There is a type III<sub>1</sub> stratum III<sub>1,a<sub>1</sub>,...,a<sub>n</sub></sub><sup>r,s,n</sup> of dimension  $\dim(\text{III}_{1,a_1,\dots,a_n}^{r,s,n}) = 17 - n$  with a finite parametrization by  $\mathbb{A}^{17-s} \times \mathbb{G}_m^{a_1} \times \dots \times \mathbb{G}_m^{a_n} \times R_r$ .

**Remark 7.8** Again, here  $\mathbb{A}^{8-s}$  parametrizes the  $8 - s$  marked  $N_0$  fibers on  $X_0$ , the  $\mathbb{G}_m^{a_i}$  parametrize the marked  $N_0$  fibers on the  $X_i$ , and  $R_r$  parametrizes the surface  $X_{n+1}$ .

Finally, we have the type III<sub>2</sub> stratum where both  $X_0$  and  $X_{n+1}$  are isotrivial  $j$ -invariant  $\infty$ . In this case,  $X_0$  and  $X_{n+1}$  are described by affine spaces of dimension  $17 - s$  and  $17 - r$ , respectively, where there are  $17 - s$  and  $17 - r$  marked  $N_0$  fibers on  $X_0$  and  $X_{n+1}$  in addition to the  $2N_1$  which each appear with multiplicity two. This gives  $42 - r - s$  total marked fibers among the end components, so  $42 - r - s \leq 24$ , and we again have two cases: this is an equality and there are no intermediate components, or this inequality is strict and there are intermediate components with  $r + s - 18$  marked fibers. Thus, as before:

**Theorem 7.9** (type III<sub>2</sub> locus) (i) *Fix the data*

$$0 \leq s, r \leq 17, \quad s + r = 18.$$

There is a type III<sub>2</sub> stratum III<sub>2</sub><sup>r,s</sup> of dimension  $\dim(\text{III}_2^{r,s}) = 16$  with a finite parametrization by  $\mathbb{A}^{17-s} \times \mathbb{A}^{17-s} = \mathbb{A}^{16}$ .

(ii) *Fix the data*

$$1 \leq s, r \leq 17, \quad 1 \leq n \leq s + r - 18, \quad \sum_{i=1}^n a_i = r + s - n - 18.$$

There is a type III<sub>2</sub> stratum III<sub>2,a<sub>1</sub>,...,a<sub>n</sub></sub><sup>r,s,n</sup> of dimension  $\dim(\text{III}_{2,a_1,\dots,a_n}^{r,s,n}) = 16 - n$  with a finite parametrization by  $\mathbb{A}^{17-s} \times \mathbb{G}_m^{a_1} \times \dots \times \mathbb{G}_m^{a_n} \times \mathbb{A}^{17-r}$ .

**Remark 7.10** In the above theorem, the  $\mathbb{A}^{17-s}$  (resp.  $\mathbb{A}^{17-r}$ ) parametrize the markings on  $X_0$  (resp.  $X_{n+1}$ ), and the  $\mathbb{G}_m^{a_i}$  parametrize the markings on the  $X_i$ .

## 8 Spaces with one marked fiber

The goal of this section is to describe the surfaces parametrized by the boundary of the moduli spaces  $\bar{\mathcal{K}}_\epsilon$  (resp.  $\bar{\mathcal{F}}_\epsilon$ ), ie the moduli spaces parametrizing one  $\epsilon$ -marked singular fiber (resp. any fiber). In Section 8.1 we describe the boundary of the two moduli spaces; see Theorem 8.1. In Section 8.2 we prove Theorem 8.2, which describes a morphism from  $\bar{\mathcal{K}}_\epsilon$  to  $\bar{\mathcal{W}}^G$ . Finally, in Section 8.3 we extend Miranda’s GIT construction to produce a moduli space of Weierstrass surfaces with a choice of marked fiber. The main result in this direction is Theorem 8.8, which shows that  $\bar{\mathcal{F}}_\epsilon$  is a smooth Deligne–Mumford stack with coarse space map  $\bar{\mathcal{F}}_\epsilon \rightarrow \widetilde{\mathcal{W}}^G$  given by the extended GIT compactification we discuss in Section 8.3.

### 8.1 Spaces with one marked fiber

In this section we first consider the moduli space  $\bar{\mathcal{F}}_\epsilon$  (see Definition 4.9), which corresponds to marking only one (possibly singular) fiber with  $\epsilon$  weight. In particular, we give a description of the surfaces parametrized by the boundary. Note that since  $\bar{\mathcal{K}}_\epsilon$  is a slice of  $\bar{\mathcal{F}}_\epsilon$ , this description also applies to the surfaces parametrized by  $\bar{\mathcal{K}}_\epsilon$ .

**Theorem 8.1** (characterization of the boundary) *The surfaces parametrized by  $\bar{\mathcal{F}}_\epsilon$  are single-component pseudoelliptic K3 surfaces whose corresponding elliptic surfaces*

are semi-log canonical Weierstrass elliptic K3s, and the marked fiber  $F$  can be any fiber other than an  $L$  type cusp. Moreover, all surfaces parametrized by  $\overline{\mathcal{F}}_\epsilon$  satisfy  $H^1(X, \mathcal{O}_X) = 0$  and  $\omega_X \cong \mathcal{O}_X$ .

**Proof** We follow the explicit stable reduction process explained in eg [8, Section 6]. Let

$$(f : \mathcal{X} \rightarrow \mathcal{C}, \mathcal{S} + \mathcal{F}) \rightarrow T$$

be a 1-parameter family whose generic fiber  $(f : X_\eta \rightarrow C_\eta, S_\eta + F_\eta)$  is a Weierstrass elliptic K3 surface with 24  $I_1$  fibers, and a single (possibly singular) marked fiber  $F_\eta$ . Denote by  $(f_0 : X_0 \rightarrow C_0, S_0 + F_0)$  the special fiber, and consider the limit obtained via twisted stable maps; see eg [7]. The limit  $(f_0 : X'_0 \rightarrow C'_0, S'_0 + F'_0)$  will be a tree of elliptic fibrations glued along twisted fibers, and the closure of the fiber  $F$  will be contained in precisely one such surface component. While this surface will be stable as a map to  $\overline{\mathcal{M}}_{1,1}$ , it will not necessarily be stable as a surface pair. To resolve this, choose some generic markings  $G = \bigcup_{i \in I} G_i$  to make the above limit stable as a surface pair. In this case,  $G$  will consist of generic smooth fibers.

As we (uniformly) lower the coefficients marking  $G$  towards 0, there will be some choice of coefficients such that the weighted stable base curve is an irreducible rational curve. Indeed, the components of the base curve will contract precisely when there is not enough weight being supported on the marked fibers. As we only lowered the coefficients marking  $G$ , and the fiber  $F'_0$  remained marked with coefficient 1, the (unique) main component, call it  $Y_0$ , fibered over the rational curve will contain the original marked fiber.

Now we have a single main component with marked fiber  $F'_0$  with type I pseudoelliptic trees attached to it. When the coefficients of  $G$  are set to 0, the type I trees will undergo type  $W_{III}$  contractions to a point to produce the Weierstrass model of  $Y_0$ , away from the fiber  $F'_0$ . When the coefficient of  $F'_0$  is reduced to  $0 < \epsilon \ll 1$ , it will cross  $W_I$  walls to become a Weierstrass fiber.

We saw in Proposition 4.11 that  $H^1(X, \mathcal{O}_X) = 0$ , so it suffices to show that  $\omega_X \cong \mathcal{O}_X$ . This holds on any Weierstrass elliptic K3 surface (see [37, Proposition III.1.1]), and since  $X$  is obtained from a Weierstrass elliptic K3 by contracting a  $(-2)$ -curve (the section), we have  $\omega_X \cong \mathcal{O}_X$ . □

## 8.2 Stable pairs to GIT/SBB

The goal of this section is to describe the morphism from  $\overline{W}_\sigma(\epsilon)$  to  $\overline{W}^G$  (and thus to  $\overline{W}^*$ ).

**Theorem 8.2** (connection with GIT/SBB) *Let  $\overline{\mathcal{K}}_\epsilon$  be the coarse moduli space of  $\overline{\mathcal{K}}_\epsilon$  and let  $\Delta \subset \overline{\mathcal{K}}_\epsilon$  be the boundary locus parametrizing surfaces with an L type cusp, with  $U = \overline{\mathcal{K}}_\epsilon \setminus \Delta$ . There is a morphism  $\overline{\mathcal{K}}_\epsilon \rightarrow \overline{\mathcal{W}}^G \cong \overline{\mathcal{W}}^*$  such that the diagram*

$$\begin{array}{ccccc}
 \Delta & \hookrightarrow & \overline{\mathcal{K}}_\epsilon & \longleftarrow & U \\
 j \downarrow & & \downarrow & & \downarrow \\
 \mathbb{P}^1 & \longrightarrow & \overline{\mathcal{W}}^G & \longleftarrow & \overline{\mathcal{W}}_s^G
 \end{array}$$

*commutes, where  $j : \Delta \rightarrow \mathbb{P}^1$  sends a surface with an L cusp to its  $j$ -invariant, the morphism  $U \rightarrow \overline{\mathcal{W}}_s^G$  is proper and finite of degree 24, and  $\mathbb{P}^1 \rightarrow \overline{\mathcal{W}}_L^G \subset \overline{\mathcal{W}}^G$  maps bijectively onto the strictly GIT semistable locus.*

**Proof** By Theorem 8.1 every surface parametrized by  $\overline{\mathcal{K}}_\epsilon$  is a single-component pseudoelliptic K3 surface. In particular, if we blow up the point to where the section contracted, we obtain an (unstable) slc Weierstrass elliptic K3 surface. Consider the  $\mathrm{PGL}_2$ -torsor  $\mathcal{P} = \{(X, s, t) \mid (s, t) \in C \cong \mathbb{P}^1\} / \sim$ , where  $X$  is an slc Weierstrass elliptic K3 surface obtained by blowing up the section of a surface parametrized by  $\overline{\mathcal{K}}_\epsilon$ ,  $s$  and  $t$  are coordinates on the base  $C \cong \mathbb{P}^1$  (or equivalently a basis for the linear series  $|F|$  of a fiber  $F$  on  $X$ ), and we quotient by scaling. Note that the Weierstrass coefficients  $(A(s, t), B(s, t))$  defining  $X$  are unique up to the scaling of the  $\mathbb{G}_m$  action  $(A, B) \mapsto (\lambda^4 A, \lambda^6 B)$ .

Since the semi-log canonical Weierstrass elliptic K3 surfaces are GIT semistable (see [36, Proposition 5.1]), we obtain a  $\mathrm{PGL}_2$ -equivariant morphism  $\mathcal{P} \rightarrow V$  which induces a morphism  $\phi : \overline{\mathcal{K}}_\epsilon \rightarrow \overline{\mathcal{W}}^G$ . □

**Remark 8.3** (i) The morphism  $\overline{\mathcal{K}}_\epsilon \rightarrow \overline{\mathcal{W}}^G$  is generically a 24-to-1 cover, as it requires the choice of some marked fiber and generically there are 24 choices. The morphism is *not* finite — eg families with one L type cusp of fixed  $j$ -invariant are all collapsed to the same polystable point.

(ii) All the underlying surfaces of pairs parametrized by  $\overline{\mathcal{K}}_\epsilon$  are in fact GIT semistable, even though all pairs with an L type cusp of fixed  $j$ -invariant map to the same GIT polystable point. One might wonder if the locus inside the GIT stack  $[V_{24}^{ss} // \mathrm{PGL}_2]$  consisting of those surfaces that appear in  $\overline{\mathcal{K}}_\epsilon$  is an open Deligne–Mumford substack with proper coarse moduli space factoring the morphism  $\overline{\mathcal{K}}_\epsilon \rightarrow \overline{\mathcal{W}}^G$ . Furthermore, it is natural to compare this to a Kirwan desingularization of  $\overline{\mathcal{W}}^G$ . We will pursue these questions in the future.

(iii) In the morphism from stable pairs to GIT, all surfaces with an L type cusp get collapsed to the polystable orbit corresponding to the KSBA-unstable but GIT semistable (unique) surface with 2L cusps of the same  $j$ -invariant.

(iv) The locus of surfaces with an L type cusp is 9-dimensional. Indeed, such surfaces are birational to a rational elliptic surface (which has an 8-dimensional moduli space) with a choice of a fiber to replace by an L type cusp. There is a  $\mathbb{P}^1$  worth of choices.

### 8.3 GIT for Weierstrass surfaces with a marked fiber

We extend Miranda’s GIT construction to produce a moduli space of Weierstrass surfaces with a choice of marked fiber. Such data can be represented by triples  $(A, B, l)$ , where  $(A, B) \in V_{4N} \oplus V_{6N}$  are Weierstrass data as above and  $l \in V_1$  is a linear form. Then  $\mathbb{G}_m \times \mathbb{G}_m \times \mathrm{SL}_2$  acts naturally on  $V_{4N} \oplus V_{6N} \oplus V_1$ , where the first  $\mathbb{G}_m$  acts on  $V_{4N} \oplus V_{6N}$  with weights  $4N$  and  $6N$  and the second acts on  $V_1$  with weight one.

To study GIT (semi)stability, we follow Miranda’s strategy. Consider the natural morphism

$$f: V_{4N} \oplus V_{6N} \rightarrow S^3 V_{4N} \oplus S^2 V_{6N},$$

let  $Z_N$  be the image of  $f$ , and let  $\mathfrak{M}_N \subset \mathbb{P}(S^3 V_{4N} \oplus S^2 V_{6N})$  be its projectivization. By [36, Propositions 3.1 and 3.2]:

**Proposition 8.4** *The morphism  $f \times \mathrm{id}: V_{4N} \oplus V_{6N} \oplus V_1 \rightarrow S^3 V_{4N} \oplus S^2 V_{6N} \oplus V_1$  is finite and  $\mathrm{SL}_2$ -equivariant with fibers contained in  $\mathbb{G}_m \times \mathbb{G}_m$  orbits. In particular, two triples  $(A, B, l)$  and  $(A', B', l')$  are in the same  $\mathbb{G}_m \times \mathbb{G}_m \times \mathrm{SL}_2$  orbit if and only if the corresponding points in  $\mathfrak{M}_N \times \mathbb{P}(V_1)$  are in the same  $\mathrm{SL}_2$  orbit.*

This lets us compute a GIT compactification of the moduli space of minimal Weierstrass fibrations with a chosen marked fiber as a GIT quotient  $(\mathfrak{M}_N \times \mathbb{P}^1) // \mathrm{SL}_2$ . We will linearize the moduli problem using the Segre embedding of  $\mathbb{P}(S^3 V_{4N} \oplus S^2 V_{6N}) \times \mathbb{P}^1$ .

**Proposition 8.5** *A triple  $(A, B, l)$  is stable if and only if it is semistable. Further, it is not stable if and only if there exists a point  $q \in \mathbb{P}^1$  with  $v_q(A) > 2N$  and  $v_q(B) > 3N$ , or with  $v_q(A) \geq 2N$ ,  $v_q(B) \geq 3N$  (with at least one equality) and  $v_q(l) = 1$ .*

**Proof** Let  $(A, B, l) \in \mathfrak{M}_N$ , let  $\lambda: \mathbb{G}_m \rightarrow \mathrm{SL}_2$  be a 1-parameter subgroup, and pick coordinates  $[T_0, T_1]$  so that  $\lambda$  acts by  $T_0 \mapsto \lambda^e T_0$  and  $T_1 \mapsto \lambda^{-e} T_1$ . Then it acts on

$(A, B, l)$  by

$$\begin{aligned}
 A &= \sum_{i=0}^{4N} a_i T_0^i t_1^{4N-i} \mapsto \sum_{i=0}^{4N} a_i \lambda^{2ei-4eN} T_0^i t_1^{4N-i}, \\
 B &= \sum_{i=0}^{6N} b_i T_0^i t_1^{6N-i} \mapsto \sum_{i=0}^{4N} b_i \lambda^{2ei-6eN} T_0^i t_1^{4N-i}, \\
 l &= l_0 T_1 + l_1 T^0 \mapsto l_0 \lambda^{-e} T_1 + l_1 \lambda^e T_0.
 \end{aligned}$$

The coordinates of  $\mathbb{P}(S^3 V_{4N} \oplus S^2 V_{6N}) \times \mathbb{P}(V_1)$  are given by  $l_0 a_i a_j a_k, l_0 b_l b_m, l_1 a_i a_j a_k,$  and  $l_0 b_l b_m$  which respectively have weights

$$\begin{aligned}
 2e(i + j + k) - 12eN - e, \quad 2e(l + m) - 12eN - e, \\
 2e(i + j + k) - 12eN + e, \quad 2e(l + m) - 12eN + e.
 \end{aligned}$$

By the Hilbert–Mumford criterion, a point is not stable (resp. semistable) if and only if there exists a 1–parameter subgroup such that all the weights are nonnegative (resp. positive).

Suppose  $(A, B, l)$  is not (semi)stable and pick a 1–parameter subgroup and coordinates as above. Then we have, after dividing by  $e \neq 0,$

$$\begin{aligned}
 2e(i + j + k) - 12eN - e < (\leq) 0 &\implies l_0 a_i a_j a_k = 0, \\
 2e(l + m) - 12eN - e < (\leq) 0 &\implies l_0 b_l b_m = 0, \\
 2e(i + j + k) - 12eN + e < (\leq) 0 &\implies l_1 a_i a_j a_k = 0, \\
 2e(l + m) - 12eN + e < (\leq) 0 &\implies l_1 b_l b_m = 0.
 \end{aligned}$$

Note that the left-hand side is always odd and so equality is never achieved. From this we can conclude that stability coincides with semistability. Now consider the cases where  $i = j = k$  and  $l = m.$  We see that  $l_0 a_i^3 = 0$  for  $i \leq 2N, l_1 a_i^3 = 0$  for  $i \leq 2N - 1, l_0 b_l^2 = 0$  for  $l \leq 3N$  and  $l_1 b_l^2 = 0$  for  $l \leq 3N - 1.$  Let  $q = [0, 1]$  be the point given by  $T_0 = 0.$  If  $l_0 \neq 0,$  then we must have that  $a_i = 0$  for  $i \leq 2N$  and  $b_l = 0$  for  $l \leq 3N.$  Thus the order of vanishing satisfies  $v_q(A) > 2N$  and  $v_q(B) > 3N.$  Otherwise, if  $l_0 = 0$  then  $l_1 \neq 0$  so we must have that  $a_i = 0$  for  $i \leq 2N - 1$  and  $b_l = 0$  for  $l \leq 3N - 1.$  In this case,  $v_q(l) = 1, v_q(A) \geq 2N$  and  $v_q(B) \geq 3N.$

Conversely, given a triple  $(A, B, l)$  satisfying such order of vanishing conditions, we may pick coordinates such that  $q = [0, 1].$  Then clearly the 1–parameter subgroup acting by  $(T_0, T_1) \mapsto (\lambda T_0, \lambda^{-1} T_1)$  demonstrates that  $(A, B, l)$  is not stable.  $\square$

In the case of K3 surfaces where  $N = 2,$  we obtain an especially pleasant result:



**Corollary 8.6** *A point of  $\mathfrak{M}_2$  is stable if and only if it represents a 1–marked Weierstrass fibration  $(f : X \rightarrow \mathbb{P}^1, S + \epsilon F)$  with at worst semi-log canonical singularities.*

**Proof** First note that the generic fiber of the fibration  $f : X \rightarrow \mathbb{P}^1$  represented by a stable point in  $\mathfrak{M}_N$  is at worst nodal, since the Weierstrass data of a stable point cannot be identically 0. Then combining Proposition 8.5 with [33, Lemmas 3.2.1 and 3.2.2 and Corollary 3.2.4], and noting that the log canonical threshold of a type L/ $N_2$  fiber is 0 (see Lemma 3.14), a point is unstable if and only if there exists a point  $q \in \mathbb{P}^1$  such that the pair  $(X, S + \epsilon F)$  is not semi-log canonical around the singular point of  $f^{-1}(q)$ . The result then follows since a Weierstrass fibration  $(X, S + \epsilon F)$  has semi-log canonical singularities away from the singular points of the fibers.  $\square$

**Definition 8.7** If  $\mathfrak{M}_2^s$  denotes the stable/semistable locus, we define  $\widetilde{W}^G = \mathfrak{M}_2^s // \text{SL}_2$ .

**Theorem 8.8**  $\overline{\mathcal{F}}_\epsilon$  is a smooth Deligne–Mumford stack with a coarse space map  $\overline{\mathcal{F}}_\epsilon \rightarrow \widetilde{W}^G$  given by the GIT compactification. Furthermore, there is a morphism  $\overline{\mathcal{F}}_\epsilon \rightarrow \overline{W}^G$  given by forgetting the marked fiber. A Weierstrass fibration  $(f : X \rightarrow \mathbb{P}^1, S)$  is represented by a point in  $\overline{W}^G$  if and only if there exists a fiber  $F$  such that  $(X, S + \epsilon F)$  is a stable pair.

**Proof** By the proof of Theorem 8.2 we obtain a birational morphism  $\overline{\mathcal{F}}_\epsilon \rightarrow [\mathfrak{M}_2^s / \text{PGL}_2]$ . On the other hand, by Corollary 8.6, there is a family of KSBA-stable one  $\epsilon$ –marked Weierstrass fibrations  $(f : X \rightarrow \mathbb{P}^1, S + \epsilon F)$  over  $\mathfrak{M}_2^s$ . This induces a  $\text{PGL}_2$  equivariant map  $\mathfrak{M}_2^s \rightarrow \overline{\mathcal{F}}_\epsilon$  which gives an inverse map  $[\mathfrak{M}_2^s / \text{PGL}_2] \rightarrow \overline{\mathcal{F}}_\epsilon$  exhibiting these as isomorphisms. Then note that  $[\mathfrak{M}_2^s / \text{PGL}_2]$  is a smooth stack, as  $\mathfrak{M}_2^s$  is an open subset of a smooth variety, so  $\overline{\mathcal{F}}_\epsilon$  is smooth.

The composition  $\overline{\mathcal{F}}_\epsilon \rightarrow [\mathfrak{M}_2^s / \text{PGL}_2] \rightarrow \mathfrak{M}_2 // \text{SL}_2$  is the coarse moduli space map. Indeed,  $[\mathfrak{M}_2^s / \text{SL}_2]$  and  $[\mathfrak{M}_2^s / \text{PGL}_2]$  have the same coarse moduli space; note that  $[\mathfrak{M}_2^s / \text{SL}_2] \rightarrow [\mathfrak{M}_2^s / \text{PGL}_2]$  is a  $\mu_2$ –gerbe since it is the base change of the map  $B\text{SL}_2 \rightarrow B\text{PGL}_2$ , so  $[\mathfrak{M}_2^s / \text{SL}_2] \rightarrow [\mathfrak{M}_2^s / \text{PGL}_2]$  is a relative coarse space and the coarse map  $[\mathfrak{M}_2^s / \text{SL}_2] \rightarrow \mathfrak{M}_2 // \text{SL}_2$  factors through it.

If  $(A, B, l)$  is in  $\mathfrak{M}_2^s$  then  $(A, B)$  is a semistable point for Miranda’s space, and conversely if  $(A, B)$  is semistable in Miranda’s space, then for a generic choice of fiber  $F$ , the corresponding fibration  $(X \rightarrow \mathbb{P}^1, S + \epsilon F)$  is a stable pair and the corresponding GIT data  $(A, B, l)$  is GIT stable.  $\square$

## References

- [1] **D Abramovich, A Vistoli**, *Complete moduli for fibered surfaces*, from “Recent progress in intersection theory” (G Ellingsrud, W Fulton, A Vistoli, editors), Birkhäuser, Boston, MA (2000) 1–31 MR Zbl
- [2] **D Abramovich, A Vistoli**, *Compactifying the space of stable maps*, J. Amer. Math. Soc. 15 (2002) 27–75 MR Zbl
- [3] **V Alexeev**, *Boundedness and  $K^2$  for log surfaces*, Internat. J. Math. 5 (1994) 779–810 MR Zbl
- [4] **V Alexeev, A Brunyate, P Engel**, *Compactifications of moduli of elliptic  $K3$  surfaces: stable pair and toroidal*, Geom. Topol. 26 (2022) 3525–3588 MR Zbl
- [5] **V Alexeev, P Engel, A Thompson**, *Stable pair compactification of moduli of  $K3$  surfaces of degree 2*, J. Reine Angew. Math. 799 (2023) 1–56 MR Zbl
- [6] **K Ascher, D Bejleri**, *Log canonical models of elliptic surfaces*, Adv. Math. 320 (2017) 210–243 MR Zbl
- [7] **K Ascher, D Bejleri**, *Moduli of fibered surface pairs from twisted stable maps*, Math. Ann. 374 (2019) 1007–1032 MR Zbl
- [8] **K Ascher, D Bejleri**, *Moduli of weighted stable elliptic surfaces and invariance of log plurigenera*, Proc. Lond. Math. Soc. 122 (2021) 617–677 MR Zbl
- [9] **K Ascher, D Bejleri**, *Smoothability of relative stable maps to stacky curves*, Épijournal Géom. Algébrique 7 (2023) art. id. 2 MR Zbl
- [10] **W L Baily, Jr, A Borel**, *Compactification of arithmetic quotients of bounded symmetric domains*, Ann. of Math. 84 (1966) 442–528 MR Zbl
- [11] **W P Barth, K Hulek, C A M Peters, A Van de Ven**, *Compact complex surfaces*, 2nd edition, Ergebnisse der Math. (3) 4, Springer (2004) MR Zbl
- [12] **A Brunyate**, *A modular compactification of the space of elliptic  $K3$  surfaces*, PhD thesis, University of Georgia (2015) Available at [http://getd.libs.uga.edu/pdfs/brunyate\\_adrian\\_201508\\_phd.pdf](http://getd.libs.uga.edu/pdfs/brunyate_adrian_201508_phd.pdf)
- [13] **C Cadman**, *Using stacks to impose tangency conditions on curves*, Amer. J. Math. 129 (2007) 405–427 MR Zbl
- [14] **I V Dolgachev**, *Mirror symmetry for lattice polarized  $K3$  surfaces*, J. Math. Sci. 81 (1996) 2599–2630 MR Zbl
- [15] **R Friedman**, *A new proof of the global Torelli theorem for  $K3$  surfaces*, Ann. of Math. 120 (1984) 237–269 MR Zbl
- [16] **R Friedman**, *The period map at the boundary of moduli*, from “Topics in transcendental algebraic geometry” (P Griffiths, editor), Ann. of Math. Stud. 106, Princeton Univ. Press (1984) 183–208 MR Zbl

- [17] **A Gathmann**, *Absolute and relative Gromov–Witten invariants of very ample hypersurfaces*, Duke Math. J. 115 (2002) 171–203 MR Zbl
- [18] **N Giansiracusa, W D Gillam**, *On Kapranov’s description of  $\overline{M}_{0,n}$  as a Chow quotient*, Turkish J. Math. 38 (2014) 625–648 MR Zbl
- [19] **C D Hacon, J McKernan, C Xu**, *Boundedness of moduli of varieties of general type*, J. Eur. Math. Soc. 20 (2018) 865–901 MR Zbl
- [20] **C D Hacon, C Xu**, *Existence of log canonical closures*, Invent. Math. 192 (2013) 161–195 MR Zbl
- [21] **A Harder, A Thompson**, *The geometry and moduli of K3 surfaces*, from “Calabi–Yau varieties: arithmetic, geometry and physics” (R Laza, M Schütt, N Yui, editors), Fields Inst. Monogr. 34, Fields Inst. Res. Math. Sci., Toronto, ON (2015) 3–43 MR Zbl
- [22] **R Hartshorne, C Polini**, *Divisor class groups of singular surfaces*, Trans. Amer. Math. Soc. 367 (2015) 6357–6385 MR Zbl
- [23] **B Hassett**, *Moduli spaces of weighted pointed stable curves*, Adv. Math. 173 (2003) 316–352 MR Zbl
- [24] **G Heckman, E Looijenga**, *The moduli space of rational elliptic surfaces*, from “Algebraic geometry 2000” (S Usui, M Green, L Illusie, K Kato, E Looijenga, S Mukai, S Saito, editors), Adv. Stud. Pure Math. 36, Math. Soc. Japan, Tokyo (2002) 185–248 MR Zbl
- [25] **G Inchiostro**, *Moduli of Weierstrass fibrations with marked section*, Adv. Math. 375 (2020) art. id. 107374 MR Zbl
- [26] **J Kollár**, *Singularities of the minimal model program*, Cambridge Tracts in Math. 200, Cambridge Univ. Press (2013) MR Zbl
- [27] **J Kollár**, *Mumford’s influence on the moduli theory of algebraic varieties*, Pure Appl. Math. Q. 17 (2021) 619–647 MR Zbl
- [28] **J Kollár**, *Families of varieties of general type* (2022) Available at <https://web.math.princeton.edu/~kollar/FromMyHomePage/modbook-final.pdf>
- [29] **J Kollár, S J Kovács**, *Log canonical singularities are Du Bois*, J. Amer. Math. Soc. 23 (2010) 791–813 MR Zbl
- [30] **J Kollár, S Mori**, *Birational geometry of algebraic varieties*, Cambridge Tracts in Math. 134, Cambridge Univ. Press (1998) MR Zbl
- [31] **J Kollár, N I Shepherd-Barron**, *Threefolds and deformations of surface singularities*, Invent. Math. 91 (1988) 299–338 MR Zbl
- [32] **S J Kovács, Z Patakfalvi**, *Projectivity of the moduli space of stable log-varieties and subadditivity of log-Kodaira dimension*, J. Amer. Math. Soc. 30 (2017) 959–1021 MR Zbl

- [33] **G La Nave**, *Explicit stable models of elliptic surfaces with sections*, preprint (2002) arXiv math/0205035
- [34] **R Laza**, *The KSBA compactification for the moduli space of degree two K3 pairs*, J. Eur. Math. Soc. 18 (2016) 225–279 MR Zbl
- [35] **R Laza, Z Zhang**, *Classical period domains*, from “Recent advances in Hodge theory” (M Kerr, G Pearlstein, editors), London Math. Soc. Lecture Note Ser. 427, Cambridge Univ. Press (2016) 3–44 MR Zbl
- [36] **R Miranda**, *The moduli of Weierstrass fibrations over  $\mathbb{P}^1$* , Math. Ann. 255 (1981) 379–394 MR Zbl
- [37] **R Miranda**, *The basic theory of elliptic surfaces*, ETS Editrice, Pisa (1989) MR Zbl
- [38] **V V Nikulin**, *Finite groups of automorphisms of Kählerian K3 surfaces*, Trudy Moskov. Mat. Obshch. 38 (1979) 75–137 MR Zbl In Russian; translated in Trans. Moscow Math. Soc 38 (1980) 71–135
- [39] **Y Odaka, Y Oshima**, *Collapsing K3 surfaces, tropical geometry and moduli compactifications of Satake, Morgan–Shalen type*, MSJ Memoirs 40, Math. Soc. Japan, Tokyo (2021) MR Zbl
- [40] **M C Olsson**, *(Log) twisted curves*, Compos. Math. 143 (2007) 476–494 MR Zbl
- [41] **U Persson**, *Configurations of Kodaira fibers on rational elliptic surfaces*, Math. Z. 205 (1990) 1–47 MR Zbl
- [42] **F Scattone**, *On the compactification of moduli spaces for algebraic K3 surfaces*, Mem. Amer. Math. Soc. 374, Amer. Math. Soc., Providence, RI (1987) MR Zbl
- [43] **M Schütt, T Shioda**, *Elliptic surfaces*, from “Algebraic geometry in East Asia” (J Keum, S Kondō, K Konno, K Oguiso, editors), Adv. Stud. Pure Math. 60, Math. Soc. Japan, Tokyo (2010) 51–160 MR Zbl
- [44] **T Shioda**, *The elliptic K3 surfaces with a maximal singular fibre*, C. R. Math. Acad. Sci. Paris 337 (2003) 461–466 MR Zbl
- [45] **R Vakil**, *The enumerative geometry of rational and elliptic curves in projective space*, J. Reine Angew. Math. 529 (2000) 101–153 MR Zbl

*Department of Mathematics, University of California, Irvine  
Irvine, CA, United States*

*Mathematics Department, Harvard University  
Cambridge, MA, United States*

kascher@uci.edu, bejleri@math.harvard.edu

Proposed: Mark Gross

Received: 8 October 2020

Seconded: Jim Bryan, Simon Donaldson

Revised: 11 November 2021

# Chern characters for supersymmetric field theories

DANIEL BERWICK-EVANS

We construct a map from  $d|1$ -dimensional Euclidean field theories to complexified  $K$ -theory when  $d = 1$  and complex-analytic elliptic cohomology when  $d = 2$ . This provides further evidence for the Stolz–Teichner program, while also identifying candidate geometric models for Chern characters within their framework. The construction arises as a higher-dimensional and parametrized generalization of Fei Han’s realization of the Chern character in  $K$ -theory as dimensional reduction for  $1|1$ -dimensional Euclidean field theories. In the elliptic case, the main new feature is a subtle interplay between the geometry of the super moduli space of  $2|1$ -dimensional tori and the derived geometry of complex-analytic elliptic cohomology. As a corollary, we obtain an entirely geometric proof that partition functions of  $\mathcal{N} = (0, 1)$  supersymmetric quantum field theories are weak modular forms, following a suggestion of Stolz and Teichner.

55N34, 81T60

## 1 Introduction and statement of results

Given a smooth manifold  $M$ , Stolz and Teichner [26] have constructed categories of  $d|1$ -dimensional super Euclidean field theories over  $M$  for  $d = 1, 2$ ,

$$(1) \quad d|1\text{-EFT}(M) := \text{Fun}^{\otimes}(d|1\text{-EBord}(M), \mathcal{V}).$$

Its objects are symmetric monoidal functors from a bordism category  $d|1\text{-EBord}(M)$  to a category of vector spaces  $\mathcal{V}$ . The morphisms of  $d|1\text{-EBord}(M)$  are  $d|1$ -dimensional super Euclidean bordisms with a map to a smooth manifold  $M$ . For details we refer to Stolz and Teichner [26, Section 4]. In [26, Sections 1.5–1.6], they conjectured the existence of cocycle maps

$$(2) \quad 1|1\text{-EFT}(M) \overset{\text{cocycle}}{\dashrightarrow} K(M) \quad \text{and} \quad 2|1\text{-EFT}(M) \overset{\text{cocycle}}{\dashrightarrow} \text{TMF}(M)$$

for  $K$ -theory and the cohomology theory of topological modular forms (TMF). In this paper we construct subcategories  $\mathcal{L}_0^{d|1}(M) \subset d|1\text{-EBord}(M)$  consisting of super

circles with maps to  $M$  when  $d = 1$ , and super tori with maps to  $M$  when  $d = 2$ , both viewed as a particular class of closed bordisms over  $M$ . A super Lie group  $\text{Euc}_{d|1}$  acts through super Euclidean isometries on super circles and super tori, inducing actions on  $\mathcal{L}_0^{d|1}(M)$  for  $d = 1, 2$ .

**Theorem 1.1** *The invariant functions  $C^\infty(\mathcal{L}_0^{d|1}(M))^{\text{Euc}_{d|1}}$  determine cocycles in 2–periodic cohomology with complex coefficients when  $d = 1$ , and cohomology with coefficients in the ring MF of weak modular forms when  $d = 2$ . Composing with restriction along  $\mathcal{L}_0^{d|1}(M) \subset d|1\text{-EBord}(M)$  determines maps from field theories to these cohomology theories over  $\mathbb{C}$ :*

$$(3) \quad 1|1\text{-EFT}(M) \xrightarrow{\text{restr}} C^\infty(\mathcal{L}_0^{1|1}(M))^{\text{Euc}_{1|1}} \xrightarrow{\text{cocycle}} H(M; \mathbb{C}[\beta, \beta^{-1}])$$

with  $|\beta| = -2$ , and

$$(4) \quad 2|1\text{-EFT}(M) \xrightarrow{\text{restr}} C^\infty(\mathcal{L}_0^{2|1}(M))^{\text{Euc}_{2|1}} \xrightarrow{\text{cocycle}} H(M; \text{MF}).$$

For  $M = \text{pt}$ , the map (4) specializes to part of an announced result of Stolz and Teichner [26, Theorem 1.15]; see Remark 3.24. Applied to general manifolds  $M$ , one can identify  $H(-; \mathbb{C}[\beta, \beta^{-1}])$  with complexified K–theory, and  $H(-; \text{MF})$  with a version of TMF over  $\mathbb{C}$ ; see Section 3.5. Hence, Theorem 1.1 proves a version of the conjectures (2) over  $\mathbb{C}$ .

We elaborate on this connection between Theorem 1.1 and the conjectures (2). The maps (3) and (4) come from sending a field theory to its partition function. This assignment defines a type of character map for field theories. Similarly, the cohomology theories in (2) have Chern characters valued in certain cohomology theories defined over  $\mathbb{C}$ . Putting these ingredients together, we obtain the diagrams

$$(5) \quad \begin{array}{ccc} 1|1\text{-EFT}(M) & \xrightarrow{\text{cocycle}} & K(M) \\ \text{restr} \downarrow & & \downarrow \text{Ch} \\ C^\infty(\mathcal{L}_0^{1|1}(M))^{\text{Euc}_{1|1}} & \xrightarrow{\text{cocycle}} & H(M; \mathbb{C}[\beta, \beta^{-1}]) \end{array}$$
  

$$\begin{array}{ccc} 2|1\text{-EFT}(M) & \xrightarrow{\text{cocycle}} & \text{TMF}(M) \\ \text{restr} \downarrow & & \downarrow \text{Ch} \\ C^\infty(\mathcal{L}_0^{2|1}(M))^{\text{Euc}_{2|1}} & \xrightarrow{\text{cocycle}} & H(M; \text{MF}) \end{array}$$

One expects the cocycle maps in (2) will make these diagrams commute. This offers new perspective on the conjectures (2), as we briefly summarize. Extending a partition

function to a full field theory requires both additional data and property: a choice of preimage under the map  $\text{restr}$  in (3) and (4) need not exist nor be unique. Similarly, refining a cohomology class over  $\mathbb{C}$  to a class in the target of (2) is both data and property: a class is in the image of the Chern character if it satisfies an integrality condition, and lifts of integral classes need not be unique owing to the presence of torsion. Up to an equivalence relation called *concordance* (see below), the conjectures (2) assert that the data and property determining such refinements — either as field theories or cohomology classes — precisely match each other.

The concordance relation features in the full conjecture of Stolz and Teichner, which asserts that the cocycle maps (2) induce bijections between concordance classes of field theories and cohomology classes. Recall that for a sheaf  $\mathcal{F}: \text{Mfld}^{\text{op}} \rightarrow \text{Set}$  on the site of manifolds, sections  $s_0, s_1 \in \mathcal{F}(M)$  are *concordant* if there exists  $s \in \mathcal{F}(M \times \mathbb{R})$  such that  $s_0 = i_0^* s$  and  $s_1 = i_1^* s$ , where  $i_0, i_1: M \hookrightarrow M \times \mathbb{R}$  are the inclusions at 0 and 1. Concordance defines an equivalence relation on the set  $\mathcal{F}(M)$ , whose equivalence classes are *concordance classes*.

**Proposition 1.2** *The assignment  $M \mapsto C^\infty(\mathcal{L}_0^{d|1}(M))^{\text{Euc}d|1}$  is a sheaf on the site of manifolds. Concordance classes of sections map surjectively to  $H(M; \mathbb{C}[\beta, \beta^{-1}])$  and  $H(M; \text{MF})$  when  $d = 1$  and  $2$ , respectively.*

There is an analogous definition of concordance for (higher) stacks, where the stack condition is used to show that the concordance relation is transitive. Assuming that  $M \mapsto d|1\text{-EFT}(M)$  is a  $d$ -stack, Proposition 1.2 implies that concordance classes of  $d|1$ -dimensional Euclidean field theories map to  $H(M; \mathbb{C}[\beta, \beta^{-1}])$  and  $H(M; \text{MF})$  for  $d = 1$  and  $2$ , respectively. We expect this to implement the Chern character for  $K$ -theory and  $\text{TMF}$  through the maps on concordance classes induced by the diagrams (5).

This brings us to a technical point: although it is expected that the assignment  $M \mapsto d|1\text{-EFT}(M)$  is a  $d$ -stack, when  $d = 2$  this statement is contingent on a fully extended enhancement of the existing definitions. This fully extended aspect is an essential ingredient in Stolz and Teichner's conjecture that concordance classes of  $2|1$ -dimensional field theories yield  $\text{TMF}$ ; see [26, Conjecture 1.17]. In this paper, the source of (4) uses the 1-categorical definition from [26]. Fully extended  $2|1$ -dimensional super Euclidean field theories should map to this 1-categorical version (via a forgetful functor), and from this one would obtain a Chern character on concordance classes via postcomposition with (4).

## 1.1 Cocycles from partition functions

In physics, the best-known topological invariants associated with the field theories (1) are the Witten index in dimension 1|1 (see eg Witten [27]), and the elliptic genus in dimension 2|1 (see eg Witten [28] or Alvarez, Killingback, Mangano and Windey [1]). These are examples of *partition functions*. For example, when  $d = 2$  the partition function of the  $\mathcal{N} = (0, 1)$  supersymmetric sigma model with target a string manifold is a modular form called the *Witten genus*; see Witten [29]. This genus led Segal [23] to suggest that certain 2–dimensional quantum field theories could provide a geometric model for elliptic cohomology.

Stolz and Teichner refined these early ideas, leading to the conjectured cocycle maps (2). In their framework (as in Segal’s [24]), partition functions are defined as the value of a field theory on closed, connected bordisms [26, Definition 4.13]. The definition of a super Euclidean field theory implies that this restriction determines a function invariant under the action by super Euclidean isometries

$$(6) \quad d|1\text{-EFT}(M) \rightarrow C^\infty(\{\text{closed bordisms over } M\})^{\text{isometries}}.$$

Fei Han [18] shows that (6) applied to a class of 1|1–dimensional closed bordisms over  $M$ ,

$$(7) \quad \text{Map}(\mathbb{R}^{0|1}, M) \simeq \text{Map}(\mathbb{R}^{1|1}/\mathbb{Z}, M)^{S^1} \subset \text{Map}(\mathbb{R}^{1|1}/\mathbb{Z}, M) \subset 1|1\text{-Bord}(M),$$

encodes the Chern character in K–theory. To summarize, restriction along (7) evaluates a 1|1–dimensional Euclidean field theory on length 1 super circles whose map to  $M$  is invariant under the action of loop rotation. This restriction is also a version of *dimensional reduction*. When the input 1|1–dimensional Euclidean field theory is constructed via Dumitrescu’s [14] super parallel transport for a vector bundle with connection, the resulting element in  $C^\infty(\text{Map}(\mathbb{R}^{0|1}, M)) \simeq \Omega^\bullet(M)$  is a differential form representative of the Chern character of that vector bundle.

The cocycle map (4) is a more elaborate version of restriction along (7). The goal is to find an appropriate class of closed 2|1–dimensional bordisms so that the restriction (6) constructs a map from 2|1–dimensional Euclidean field theories to complex-analytic elliptic cohomology. There are two main problems to be solved in this 2–dimensional generalization. First, one cannot specialize to a particular super torus, as in the specialization to the length 1 super circle in (7). Indeed, elliptic cohomology over  $\mathbb{C}$  is parametrized by the moduli of all complex-analytic elliptic curves. This problem is



easy enough to solve, though its resolution introduces some technicalities: one restricts to a moduli *stack* of super tori.

The second obstacle is more serious. Stolz and Teichner's field theories are neither chiral nor conformal, and hence restriction only gives a *smooth* function on the moduli stack of super Euclidean tori. On the other hand, a class in complex-analytic elliptic cohomology only depends on the holomorphic part of the conformal modulus of a torus. Resolving this apparent mismatch comes through a surprising feature of the super moduli space  $\mathcal{L}_0^{2|1}(M)$ : the failure of conformality and holomorphy is measured by a specified de Rham coboundary; see Proposition 1.5. Loosely, this shows that functions on  $\mathcal{L}_0^{2|1}(M)$  possess a kind of *derived* holomorphy and conformality.

## 1.2 Outline of the proof

Theorem 1.1 boils down to somewhat technical computations in supermanifolds, so we briefly outline the approach and state key intermediate results in terms of ordinary (nonsuper) geometry. There are three main steps in the construction:

- (i) Construct the super moduli spaces  $\mathcal{L}_0^{d|1}(M)$ .
- (ii) Compute the algebras of  $\text{Euc}_{d|1}$ -invariant functions  $C^\infty(\mathcal{L}_0^{d|1}(M))^{\text{Euc}_{d|1}}$  in terms of differential form data on  $M$ .
- (iii) Construct the cocycle maps (3) and (4) using the output of step (ii).

The main work is in step (ii), culminating in Propositions 1.4 and 1.5 below.

For step (i), we start by defining

$$(8) \quad \mathcal{L}^{d|1}(M) := \mathcal{M}^{d|1} \times \text{Map}(\mathbb{R}^{d|1}/\mathbb{Z}^d, M), \quad \mathcal{L}^{d|1}(M) \subset d|1\text{-Bord}(M),$$

where  $\mathcal{M}^{d|1}$  is the moduli space of super Euclidean structures on  $\mathbb{R}^{d|1}/\mathbb{Z}^d$ , and  $\text{Map}(\mathbb{R}^{d|1}/\mathbb{Z}^d, M)$  is the generalized supermanifold of maps from  $\mathbb{R}^{d|1}/\mathbb{Z}^d$  to  $M$ . Hence, an  $S$ -point of  $\mathcal{L}^{1|1}(M)$  determines a family of super Euclidean circles with a map to  $M$ , and an  $S$ -point of  $\mathcal{L}^{2|1}(M)$  determines a family of super Euclidean tori with a map to  $M$ . There is a canonical functor  $\mathcal{L}^{d|1}(M) \rightarrow d|1\text{-Bord}(M)$ , regarding these supermanifolds as bordisms from the empty set to the empty set. Next we consider the subobject of (8) gotten by taking maps invariant under the  $\mathbb{R}^d$ -action on  $\mathbb{R}^{d|1}/\mathbb{Z}^d$  by precomposition. Equivalently, this is the  $S^1 = \mathbb{R}/\mathbb{Z}$ -fixed subspace when  $d = 1$  and the  $T^2 = \mathbb{R}^2/\mathbb{Z}^2$ -fixed subspace when  $d = 2$ . This yields finite-dimensional subobjects

$$(9) \quad \mathcal{M}^{d|1} \times \text{Map}(\mathbb{R}^{0|1}, M) \simeq \mathcal{L}_0^{d|1}(M) := \mathcal{L}^{d|1}(M)^{\mathbb{R}^d/\mathbb{Z}^d} \subset \mathcal{L}^{d|1}(M)$$

that, roughly speaking, are the subspaces of maps that are constant up to nilpotents. Restricting a field theory along the composition  $\mathcal{L}_0^{d|1}(M) \subset \mathcal{L}^{d|1}(M) \rightarrow d|1\text{-Bord}(M)$  extracts a function, providing the first arrow in (3) and (4),

$$(10) \quad \text{restr}: d|1\text{-EFT}(M) \rightarrow C^\infty(\mathcal{L}_0^{d|1}(M))^{\text{Euc}_{d|1}}.$$

See Lemmas 2.12 and 3.15.

**Remark 1.3** The restriction (10) is dimensional reduction in the sense of [10, Glossary], though it differs from dimensional reduction in the sense of [26, Section 1.3].

Step (ii) is a technical computation. The  $d = 1$  case is characterized as follows.

**Proposition 1.4** *The elements of  $C^\infty(\mathcal{L}_0^{1|1}(M))^{\text{Euc}_{1|1}}$  are in bijection with pairs  $(Z, Z_\ell)$ , where*

$$(11) \quad Z \in (\Omega_{\text{cl}}^\bullet(M; C^\infty(\mathbb{R}_{>0})[\beta, \beta^{-1}]))^0, \quad Z_\ell \in (\Omega^\bullet(M; C^\infty(\mathbb{R}_{>0})[\beta, \beta^{-1}]))^{-1},$$

with  $|\beta| = -2$ . Here  $Z$  is closed of total degree zero,  $Z_\ell$  is of total degree  $-1$ , and they satisfy

$$(12) \quad \partial_\ell Z = dZ_\ell,$$

where  $d$  is the de Rham differential on  $M$ , and  $\partial_\ell$  is the vector field on  $\mathbb{R}_{>0}$  associated to the standard coordinate  $\ell \in C^\infty(\mathbb{R}_{>0})$ .

For the  $d = 2$  case, let  $\mathbb{H} \subset \mathbb{C}$  denote the upper half-plane with standard complex coordinates  $\tau, \bar{\tau} \in C^\infty(\mathbb{H})$ , and let  $v \in C^\infty(\mathbb{R}_{>0})$  be the standard coordinate.

**Proposition 1.5** *The elements of  $C^\infty(\mathcal{L}_0^{2|1}(M))^{\text{Euc}_{2|1}}$  are in bijection with triples  $(Z, Z_{\bar{\tau}}, Z_v)$ , where*

$$(13) \quad \begin{aligned} Z &\in (\Omega_{\text{cl}}^\bullet(M; C^\infty(\mathbb{H} \times \mathbb{R}_{>0})[\beta, \beta^{-1}])^{\text{SL}_2(\mathbb{Z})})^0, \\ Z_{\bar{\tau}}, Z_v &\in (\Omega^\bullet(M; C^\infty(\mathbb{H} \times \mathbb{R}_{>0})[\beta, \beta^{-1}]))^{-1}, \end{aligned}$$

with  $|\beta| = -2$ . Here  $Z$  is closed of total degree zero,  $Z_{\bar{\tau}}$  and  $Z_v$  are of total degree  $-1$ , they satisfy an  $\text{SL}_2(\mathbb{Z})$ -invariance property stated in Lemma 3.23, and

$$(14) \quad \partial_v Z = dZ_v \quad \text{and} \quad \partial_{\bar{\tau}} Z = dZ_{\bar{\tau}},$$

where  $d$  is the de Rham differential on  $M$ , and  $\partial_{\bar{\tau}}$  and  $\partial_v$  are vector fields on  $\mathbb{H}$  and  $\mathbb{R}_{>0}$ .

In Propositions 1.4 and 1.5, the closed differential form  $Z$  arises by restriction to a subspace

$$(15) \quad \mathbb{R}_{>0} \times \text{Map}(\mathbb{R}^{0|1}, M) \hookrightarrow \mathcal{L}_0^{1|1}(M),$$

$$(16) \quad \text{Lat} \times \text{Map}(\mathbb{R}^{0|1}, M) \hookrightarrow \mathcal{L}_0^{2|1}(M),$$

where  $\text{Lat}$  is the space of based, oriented lattices in  $\mathbb{C}$ . Indeed, (11) and (13) come from

$$(17) \quad \begin{aligned} C^\infty(\mathbb{R}_{>0} \times \text{Map}(\mathbb{R}^{0|1}, M))^{\text{Euc}_{1|1}} &\simeq (\Omega_{\text{cl}}(M; C^\infty(\mathbb{R}_{>0})[\beta, \beta^{-1}]))^0, \\ C^\infty(\text{Lat} \times \text{Map}(\mathbb{R}^{0|1}, M))^{\text{Euc}_{2|1}} &\simeq (\Omega^\bullet(M; C^\infty(\mathbb{H} \times \mathbb{R}_{>0})[\beta, \beta^{-1}])^{\text{SL}_2(\mathbb{Z})})^0. \end{aligned}$$

When  $d = 1$ ,  $\ell \in \mathbb{R}_{>0}$  corresponds to (super) circles of length  $\ell$ , and (12) shows that the failure of  $Z \in C^\infty(\mathbb{R}_{>0} \times \text{Map}(\mathbb{R}^{0|1}, M))^{\text{Euc}_{1|1}}$  to be independent of this length is  $d$ -exact. When  $d = 2$ , a point  $(\tau, \bar{\tau}, v) \in \mathbb{H} \times \mathbb{R}_{>0}$  corresponds to (super) Euclidean tori with conformal modulus  $(\tau, \bar{\tau})$  and total volume  $v$ . Then  $Z_v$  and (14) show that the failure of  $Z \in C^\infty(\text{Lat} \times \text{Map}(\mathbb{R}^{0|1}, M))^{\text{Euc}_{2|1}}$  to be independent of the volume is  $d$ -exact. Similarly,  $Z_{\bar{\tau}}$  and (14) show that the failure of  $Z$  to depend holomorphically on the conformal modulus is  $d$ -exact. This is the precise sense in which functions on  $\mathcal{L}_0^{2|1}(M)$  exhibit a derived version of holomorphy and conformality.

Finally for step (iii), we consider the maps, with notation from Propositions 1.4 and 1.5,

$$(18) \quad C^\infty(\mathcal{L}_0^{1|1}(M)) \rightarrow \text{H}(M; C^\infty(\mathbb{R}_{>0})[\beta, \beta^{-1}]), \quad (Z, Z_\ell) \mapsto [Z],$$

$$(19) \quad C^\infty(\mathcal{L}_0^{2|1}(M)) \rightarrow \text{H}(M; C^\infty(\mathbb{H} \times \mathbb{R}_{>0})[\beta, \beta^{-1}]^{\text{SL}_2(\mathbb{Z})}), \quad (Z, Z_{\bar{\tau}}, Z_\ell) \mapsto [Z],$$

where  $|\beta| = -2$  and has weight 1 for  $\text{SL}_2(\mathbb{Z})$ , meaning  $\beta \mapsto (c\tau + d)\beta$ .

**Proof of Theorem 1.1 from Propositions 1.4 and 1.5** Starting with the  $d = 1$  case, we claim that the map (18) factors through cohomology with coefficients in the subring  $\mathbb{C}[\beta, \beta^{-1}] \hookrightarrow C^\infty(\mathbb{R}_{>0})[\beta, \beta^{-1}]$ , including as the constant functions on  $\mathbb{R}_{>0}$ . Indeed, observe that

$$(20) \quad \partial_\ell[Z] = [\partial_\ell Z] = [dZ_\ell] = 0,$$

using (12). Hence,  $[Z] \in \text{H}(M; \mathbb{C}[\beta, \beta^{-1}]) \subset \text{H}(M; C^\infty(\mathbb{R}_{>0})[\beta, \beta^{-1}])$ , and (18) determines the cocycle map in (3).

Similarly, the map (19) factors through cohomology with coefficients in the subring

$$(21) \quad \text{MF} \simeq (\mathcal{O}(\mathbb{H})[\beta, \beta^{-1}])^{\text{SL}_2(\mathbb{Z})} \hookrightarrow (C^\infty(\mathbb{H} \times \mathbb{R}_{>0})[\beta, \beta^{-1}])^{\text{SL}_2(\mathbb{Z})},$$

where  $\text{MF}$  is the ring of weak modular forms; see Definition 3.26. The map (21) is the pullback of smooth functions along the projection  $\mathbb{H} \times \mathbb{R}_{>0} \rightarrow \mathbb{H}$  composed with the inclusion  $\mathcal{O}(\mathbb{H}) \subset C^\infty(\mathbb{H})$ . Indeed, we have

$$\partial_v[Z] = [\partial_v Z] = [dZ_v] = 0 \quad \text{and} \quad \partial_{\bar{v}}[Z] = [\partial_{\bar{v}} Z] = [dZ_{\bar{v}}] = 0$$

using (14), where the first set of equalities demonstrate independence from  $\mathbb{R}_{>0}$ , while the second demonstrate holomorphic dependence on  $\mathbb{H}$ . Finally, the  $\text{SL}_2(\mathbb{Z})$ -invariance property for  $Z$  (see Lemma 3.23) shows that  $[Z]$  is indeed a cohomology class valued in modular forms,

$$[Z] \in H(M; \text{MF}) \subset H(M; C^\infty(\mathbb{H} \times \mathbb{R}_{>0})[\beta, \beta^{-1}]^{\text{SL}_2(\mathbb{Z})}),$$

and hence (19) determines the cocycle map in (4).

Surjectivity of the cocycle maps (3) and (4) follows from the inclusions

$$\begin{aligned} \Omega_{\text{cl}}^\bullet(M; \mathbb{C}[\beta, \beta^{-1}]) &\hookrightarrow C^\infty(\mathcal{L}_0^{1|1}(M)), & \omega &\mapsto (\omega, 0) = (Z, Z_\ell), \\ \Omega_{\text{cl}}^\bullet(M; \text{MF}) &\hookrightarrow C^\infty(\mathcal{L}_0^{2|1}(M)), & \omega &\mapsto (\omega, 0, 0) = (Z, Z_{\bar{v}}, Z_v), \end{aligned}$$

using the description of functions from Propositions 1.4 and 1.5 and the maps on coefficients described in the previous two paragraphs. The definition of the maps (18) and (19) together with the de Rham theorem then implies that every cohomology class admits a refinement to a function on  $\mathcal{L}_0^{d|1}(M)$ .  $\square$

The following remarks relate our results to other work.

**Remark 1.6** The above analysis of the moduli space of super Euclidean tori is related to previous investigations of moduli spaces of super Riemann surfaces in the string theory literature; see eg Donagi and Witten [13] and Witten [30]. However, the vast majority of prior constructions in string theory and in the Stolz–Teichner program only study the reduced moduli spaces. In particular, the cocycle models for (equivariant) elliptic cohomology in Berwick-Evans [7; 6], Barthel, Berwick-Evans and Stapleton [3] and Berwick-Evans and Tripathy [8] arise as functions on the reduced moduli space. In this prior work, the correct mathematical object comes only after imposing holomorphy by hand. However, as Theorem 1.1 shows, this property emerges naturally from the geometry of  $2|1$ -dimensional super tori.

**Remark 1.7** When  $M = \text{pt}$ , Proposition 1.5 shows that partition functions of  $\mathcal{N} = (0, 1)$  supersymmetric quantum field theories are weak modular forms:  $\Omega^{\text{odd}}(\text{pt}) = \{0\}$ ,

so  $Z_v = Z_{\bar{\tau}} = 0$  are no additional data. In contrast to the arguments in the physics literature that analyze a particular action functional (eg [9, Sections 4.3–4.4]), the proof here emerges entirely from the geometry of the moduli space of super Euclidean tori. This recovers Stolz and Teichner’s claim from [26, page 10] that “holomorphicity is a consequence of the more intricate structure of the moduli stack of supertori”.

**Remark 1.8** The data  $Z_{\bar{\tau}}$  in Proposition 1.5 is closely related to *anomaly cancellation* in physics and choices of *string structures* in geometry. An illustrative example is the elliptic Euler class: an oriented vector bundle  $V \rightarrow M$  determines a class  $[\text{Eu}(V)] \in H(M; \text{MF})$  if the Pontryagin class  $[p_1(V)] \in H^4(M; \mathbb{R})$  vanishes. In Section 3.7 we show that the set of differential forms  $H \in \Omega^3(M; \mathbb{R})$  with  $p_1(V) = dH$  parametrizes cocycle refinements of  $[\text{Eu}(V)]$  to a function on  $\mathcal{L}_0^{2|1}(M)$ . Geometrically,  $H$  is part of the data of a string structure on  $V$ . In physics,  $H$  is part of the data for anomaly cancellation in a theory of  $V$ -valued free fermions. Under the conjectured cocycle maps (2),  $V$ -valued free fermions are expected to furnish representatives of elliptic Euler classes in  $\text{TMF}(M)$ ; see Stolz and Teichner [25, Section 4.4]. Perturbative quantization of fermions rigorously constructs elliptic Euler cocycles over  $\mathbb{C}$  (see Berwick-Evans [6, Section 6]), and Theorem 1.1 shows that lifting a cohomology class to a 2|1-dimensional Euclidean field theory must depend on a *choice* of string structure, at least rationally.

**Remark 1.9** If the input field theory in (4) is super conformal, then  $dZ_v = 0$ , whereas if the input theory is holomorphic then  $dZ_{\bar{\tau}} = 0$ . For a general field theory (not necessarily conformal or holomorphic) the differential form  $\partial_{\bar{\tau}} Z_{\ell} - \partial_{\ell} Z_{\bar{\tau}}$  is closed. These closed forms have the potential to encode secondary cohomological invariants of field theories. Although we do not know explicit field theories for which this cohomology class is nonzero, the structure appears to be related to mock modular phenomena and the  $\text{TMF}$ -valued torsion invariants studied in Gaiotto, Johnson-Freyd and Witten [17] and Gaiotto and Johnson-Freyd [16].

**Remark 1.10** In light of Fei Han’s work [18] on the Bismut–Chern character, it is tempting to think of the restriction  $2|1\text{-EFT}(M) \rightarrow C^{\infty}(\mathcal{L}^{2|1}(M))^{\text{Euc}_{2|1}}$  (without taking  $T^2$ -invariant maps) as a candidate construction of the *elliptic* Bismut–Chern character. Indeed, functions on  $C^{\infty}(\mathcal{L}^{2|1}(M))^{\text{Euc}_{2|1}}$  can be identified with cocycles analogous to (14), where  $Z$  is a differential form on the double loop space and the

de Rham differential  $d$  is replaced with the  $T^2$ -equivariant differential investigated in Berwick-Evans [5].

### 1.3 Conventions for supermanifolds

This paper works in the category of supermanifolds with structure sheaves defined over  $\mathbb{C}$ ; this is called the category of cs-supermanifolds in Deligne and Morgan [12]. The majority of what we require is covered in the concise introduction [26, Section 4.1], but we establish a little notation presently. First, all functions and differential forms are  $\mathbb{C}$ -valued. The supermanifolds  $\mathbb{R}^{n|m}$  are characterized by their super algebra of functions  $C^\infty(\mathbb{R}^{n|m}) \simeq C^\infty(\mathbb{R}^n; \mathbb{C}) \otimes_{\mathbb{C}} \Lambda^* \mathbb{C}^m$ . The representable presheaf associated with  $\mathbb{R}^{n|m}$  assigns to a supermanifold  $S$  the set

$$\mathbb{R}^{n|m}(S) := \{t_1, t_2, \dots, t_n \in C^\infty(S)^{\text{ev}}, \theta_1, \theta_2, \dots, \theta_m \in C^\infty(S)^{\text{odd}} \mid (t_i)_{\text{red}} = \overline{(t_i)_{\text{red}}}\},$$

where  $(t_i)_{\text{red}}$  denotes the restriction of a function to the reduced manifold  $S_{\text{red}} \hookrightarrow S$ , and  $\overline{(t_i)_{\text{red}}}$  is the conjugate of the complex-valued function  $(t_i)_{\text{red}}$  on the smooth manifold  $S_{\text{red}}$ . We use this functor of points description throughout the paper, typically with Roman letters denoting even functions and Greek letters denoting odd functions.

We follow Stolz and Teichner's terminology, wherein a presheaf on supermanifolds is called a *generalized supermanifold*. An example of a generalized supermanifold is  $\text{Map}(X, Y)$  for supermanifolds  $X$  and  $Y$ , which assigns to a supermanifold  $S$  the set of maps  $S \times X \rightarrow Y$ . For a manifold  $M$  regarded as a supermanifold, the generalized supermanifold  $\text{Map}(\mathbb{R}^{0|1}, M)$  is isomorphic to the representable presheaf associated to the odd tangent bundle  $\Pi TM$ , as we recall briefly. We use the notation  $(x, \psi) \in \Pi TM(S)$  for an  $S$ -point, where  $x: S \rightarrow M$  is a map and  $\psi \in \Gamma(S; x^* TM)^{\text{odd}}$  is an odd section. This gives an  $S$ -point  $(x + \theta\psi) \in \text{Map}(\mathbb{R}^{0|1}, M)$  by identifying  $x$  with an algebra map  $x: C^\infty(M) \rightarrow C^\infty(S)$  and  $\psi: C^\infty(M) \rightarrow C^\infty(S)$  with an odd derivation relative to  $x$ . These fit together to define an algebra map

$$(22) \quad C^\infty(M) \xrightarrow{(x, \psi)} C^\infty(S) \oplus \theta \cdot C^\infty(S) \simeq C^\infty(S \times \mathbb{R}^{0|1}),$$

with the isomorphism coming from Taylor expansion in a choice of odd coordinate  $\theta \in C^\infty(\mathbb{R}^{0|1})$ . The map (22) is equivalent to  $S \times \mathbb{R}^{0|1} \rightarrow M$ , ie an  $S$ -point of  $\text{Map}(\mathbb{R}^{0|1}, M)$ . The functions  $C^\infty(\text{Map}(\mathbb{R}^{0|1}, M)) \simeq C^\infty(\Pi TM) \simeq \Omega^\bullet(M)$  recover differential forms on  $M$  as a  $\mathbb{Z}/2$ -graded  $\mathbb{C}$ -algebra. The action of automorphisms of  $\mathbb{R}^{0|1}$  on this algebra encode the de Rham differential and the grading operator on forms; see eg [19, Section 3].

**Acknowledgements** It is a pleasure to thank Bertram Arnold, Theo Johnson-Freyd, Stephan Stolz, Peter Teichner, and Arnav Tripathy for fruitful conversations that shaped this work, as well as a referee for finding a mistake in a previous draft and making several suggestions that improved the clarity and precision of the paper.

## 2 A map from 1|1–Euclidean field theories to complexified K–theory

The main goal of this section is to prove Proposition 1.4. From the discussion in Section 1.2, this proves the  $d = 1$  case of Theorem 1.1. We also prove Proposition 1.2 when  $d = 1$ , and connect this result with Chern characters of super connections.

### 2.1 The moduli space of super Euclidean circles

**Definition 2.1** Let  $\mathbb{E}^{1|1}$  denote the super Lie group with underlying supermanifold  $\mathbb{R}^{1|1}$  and multiplication

$$(23) \quad (t, \theta) \cdot (t', \theta') = (t + t' + i\theta\theta', \theta + \theta') \quad \text{for } (t, \theta), (t', \theta') \in \mathbb{R}^{1|1}(S).$$

Define the *super Euclidean group* as  $\text{Eucl}_{1|1} := \mathbb{E}^{1|1} \rtimes \mathbb{Z}/2$ , where the semidirect product is defined using the  $\mathbb{Z}/2 = \{\pm 1\}$ –action by reflection,  $(t, \theta) \mapsto (t, \pm\theta)$ , for  $(t, \theta) \in \mathbb{E}^{1|1}(S)$ .

The super Lie algebra of  $\mathbb{E}^{1|1}$  is generated by a single odd element, namely the left-invariant vector field  $D = \partial_\theta - i\theta\partial_t$ . The right-invariant generator is  $Q = \partial_\theta + i\theta\partial_t$ . The super commutators are

$$(24) \quad \frac{1}{2}[D, D] = D^2 = -i\partial_t \quad \text{and} \quad \frac{1}{2}[Q, Q] = Q^2 = i\partial_t.$$

**Remark 2.2** The factors of  $i = \sqrt{-1}$  in (23) and (24) come from Wick rotation; see eg [12, page 95, Example 4.9.3]. This differs from the convention for the 1|1–dimensional Euclidean group in [20, Definition 33], but is more closely aligned with the Wick rotated 2|1–dimensional Euclidean geometry defined in [26, Section 4.2] and studied below.

Let  $\mathbb{R}_{>0}^{1|1}$  denote the supermanifold gotten by restricting the structure sheaf of  $\mathbb{R}^{1|1}$  to the positive reals,  $\mathbb{R}_{>0} \subset \mathbb{R}$ .

**Definition 2.3** Given an  $S$ -point  $(\ell, \lambda) \in \mathbb{R}_{>0}^{1|1}(S)$ , the family of  $1|1$ -dimensional super Euclidean circles is defined as the quotient

$$(25) \quad S_{\ell, \lambda}^{1|1} := (S \times \mathbb{R}^{1|1})/\mathbb{Z}$$

for the left  $\mathbb{Z}$ -action over  $S$  determined by the formula

$$(26) \quad n \cdot (t, \theta) = (t + n\ell + in\lambda\theta, n\lambda + \theta) \quad \text{for } n \in \mathbb{Z}(S), (t, \theta) \in \mathbb{R}^{1|1}(S).$$

Equivalently this is the restriction of the left  $\mathbb{E}^{1|1}$ -action on  $S \times \mathbb{R}^{1|1}$  to the  $S$ -family of subgroups  $\mathbb{Z} \times S \subset \mathbb{E}^{1|1} \times S$  with generator

$$\{1\} \times S \simeq S \xrightarrow{(\ell, \lambda)} \mathbb{R}_{>0}^{1|1} \times S \subset \mathbb{E}^{1|1} \times S.$$

Define the *standard super Euclidean circle*, denoted by  $S^{1|1} = S_{1,0}^{1|1} = \mathbb{R}^{1|1}/\mathbb{Z}$ , as the quotient by the action for the standard inclusion  $\mathbb{Z} \subset \mathbb{R} \subset \mathbb{E}^{1|1}$ .

**Remark 2.4** The  $S$ -family of subgroups  $S \times \mathbb{Z} \hookrightarrow S \times \mathbb{E}^{1|1}$  generated by  $(\ell, \lambda) \in \mathbb{R}_{>0}^{1|1}(S)$  is normal if and only if  $\lambda = 0$ . Hence, the standard super circle  $S^{1|1}$  inherits a group structure from  $\mathbb{E}^{1|1}$ , but a generic  $S$ -family of super Euclidean circles  $S_{\ell, \lambda}^{1|1}$  does not.

**Remark 2.5** There is a more general notion of a family of super circles where (26) incorporates the action by  $\mathbb{Z}/2 < \text{Euc}_{1|1}$ . This moduli space has two connected components corresponding to choices of spin structure on the underlying ordinary circle, with the component from Definition 2.3 corresponding to the odd (or nonbounding) spin structure. This turns out to be the relevant component to recover complexified  $K$ -theory.

We recall [26, Definitions 2.26, 2.33 and 4.4]: for a supermanifold  $\mathbb{M}$  with an action by a super Lie group  $G$ , an  $(\mathbb{M}, G)$ -structure on a family of supermanifolds  $T \rightarrow S$  is an open cover  $\{U_i\}$  of  $T$  with isomorphisms to open sub-supermanifolds  $\varphi: U_i \xrightarrow{\sim} V_i \subset S \times \mathbb{M}$  and transition data  $g_{ij}: V_i \cap V_j \rightarrow G$  compatible with the  $\varphi_i$  and satisfying a cocycle condition. An *isometry* between supermanifolds with  $(\mathbb{M}, G)$ -structure is defined as a map  $T \rightarrow T'$  over  $S$  that is locally given by the  $G$ -action on  $\mathbb{M}$ , relative to the open covers  $\{U_i\}$  of  $T$  and  $\{U'_i\}$  of  $T'$ . Supermanifolds with  $(\mathbb{M}, G)$ -structure and isometries form a category fibered over supermanifolds.

**Definition 2.6** [26, Section 4.2] A *super Euclidean* structure on a  $1|1$ -dimensional family  $T \rightarrow S$  is an  $(\mathbb{M}, G)$ -structure for the left action of  $G = \text{Euc}_{1|1}$  on  $\mathbb{M} = \mathbb{R}^{1|1}$ .



**Lemma 2.7** *An  $S$ -family of super circles (25) has a canonical super Euclidean structure.*

**Proof** We endow a family of super circles with a  $1|1$ -dimensional Euclidean structure as follows. Take the open cover  $S \times \mathbb{R}^{1|1} \rightarrow S^{1|1}_{\ell,\lambda}$  supplied by the quotient map, and take transition data from the  $\mathbb{Z}$ -action on  $S \times \mathbb{R}^{1|1}$ . By definition this  $\mathbb{Z}$ -action is through super Euclidean isometries, and so the quotient inherits a super Euclidean structure.  $\square$

We observe that every family of super circles pulls back from the universal family  $(\mathbb{R}^{1|1}_{>0} \times \mathbb{R}^{1|1})/\mathbb{Z} \rightarrow \mathbb{R}^{1|1}_{>0}$  along a map  $S \rightarrow \mathbb{R}^{1|1}_{>0}$ . Hence,

$$\mathcal{M}^{1|1} := \mathbb{R}^{1|1}_{>0} \quad \text{and} \quad \mathcal{S}^{1|1} := (\mathbb{R}^{1|1}_{>0} \times \mathbb{R}^{1|1})/\mathbb{Z} \rightarrow \mathbb{R}^{1|1}_{>0}$$

are the moduli space of super Euclidean circles and the universal family of super Euclidean circles, respectively. The following shows that  $\mathcal{M}^{1|1} = \mathbb{R}^{1|1}_{>0}$  can equivalently be viewed as the moduli space of super Euclidean structures on the standard super circle.

**Lemma 2.8** *There exists an isomorphism of supermanifolds over  $\mathbb{R}^{1|1}_{>0}$ ,*

$$(27) \quad \mathbb{R}^{1|1}_{>0} \times \mathcal{S}^{1|1} \xrightarrow{\sim} \mathcal{S}^{1|1},$$

*from the constant  $\mathbb{R}^{1|1}_{>0}$ -family with fiber the standard super circle, to the universal family of super circles. This isomorphism does not preserve the super Euclidean structure on  $\mathcal{S}^{1|1}$ .*

**Proof** Define the map

$$(28) \quad \mathbb{R}^{1|1}_{>0} \times \mathbb{R}^{1|1} \rightarrow \mathbb{R}^{1|1}_{>0} \times \mathbb{R}^{1|1}, \quad (\ell, \lambda, t, \theta) \mapsto (\ell, \lambda, t(\ell + i\lambda\theta), \theta + t\lambda),$$

for  $(\ell, \lambda) \in \mathbb{R}^{1|1}(S)$  and  $(t, \theta) \in \mathbb{R}^{1|1}(S)$ . Observe that (28) is  $\mathbb{Z}$ -equivariant for the action on the source and target given by

$$n \cdot (\ell, \lambda, t, \theta) = (\ell, \lambda, t + n, \theta) \quad \text{and} \quad n \cdot (\ell, \lambda, t, \theta) = (\ell, \lambda, t + n(\ell + i\lambda\theta), \theta + n\lambda),$$

respectively. Hence (28) determines a map between the respective  $\mathbb{Z}$ -quotients, defining a map (27). This is easily seen to be an isomorphism of supermanifolds. Since (27) is not locally determined by the action of  $\text{Euc}_{1|1}$  on  $\mathbb{R}^{1|1}$ , it is not a super Euclidean isometry.  $\square$

The following result gives an  $S$ -point formula for the action of  $\text{Euc}_{1|1}$  on  $\mathcal{S}^{1|1}$  and  $\mathcal{M}^{1|1} = \mathbb{R}^{1|1}_{>0}$  coming from isometries between super Euclidean circles.

**Lemma 2.9** Given  $(\ell, \lambda) \in \mathbb{R}_{>0}^{1|1}(S) = \mathcal{M}^{1|1}(S)$  and  $(s, \eta, \pm 1) \in (\mathbb{E}^{1|1} \rtimes \mathbb{Z}/2)(S) = \text{Eucl}_{1|1}(S)$ , there is an isometry  $f_{(s,\eta,\pm 1)}: S_{\ell,\lambda}^{1|1} \rightarrow S_{\ell',\lambda'}^{1|1}$  of super Euclidean circles over  $S$  sitting in the diagram

$$\begin{array}{ccc} S \times \mathbb{R}^{1|1} & \xrightarrow{(s,\eta,\pm 1) \cdot} & S \times \mathbb{R}^{1|1} \\ \downarrow & & \downarrow \\ S_{\ell,\lambda}^{1|1} & \xrightarrow{f_{(s,\eta,\pm 1)}} & S_{\ell',\lambda'}^{1|1} \end{array}$$

where the upper horizontal arrow is determined by the left  $\text{Eucl}_{1|1}$ -action on  $\mathbb{R}^{1|1}$ , the left vertical arrow is the quotient map (51) for  $(\ell, \lambda)$ , and the right vertical arrow is the quotient map for

(29)  $(\ell', \lambda') := (\ell \pm 2i\eta\lambda, \pm\lambda).$

**Proof** Consider the diagram

(30) 
$$\begin{array}{ccc} \mathbb{Z} \times S \times \mathbb{R}^{1|1} & \xrightarrow{(s,\eta,\pm 1) \cdot} & \mathbb{Z} \times S \times \mathbb{R}^{1|1} \\ (\ell,\lambda) \cdot \downarrow & & \downarrow (\ell',\lambda') \cdot \\ S \times \mathbb{R}^{1|1} & \xrightarrow{(s,\eta,\pm 1) \cdot} & S \times \mathbb{R}^{1|1} \end{array}$$

where the horizontal arrows denote the left action of  $(s, \eta, \pm 1) \in \text{Eucl}_{1|1}(S)$  on  $S \times \mathbb{R}^{1|1}$  while the vertical arrows denote the left  $\mathbb{Z}$ -action generated by  $(\ell, \lambda), (\ell', \lambda') \in \mathbb{R}_{>0}^{1|1}(S)$ . The square (30) commutes if and only if  $(\ell', \lambda') = (s, \eta, \pm 1) \cdot (\ell, \lambda) \cdot (s, \eta, \pm 1)^{-1} \in \mathbb{R}_{>0}^{1|1}(S) \subset \mathbb{E}^{1|1}(S)$ , ie (29) holds. Commutativity of the diagram (30) gives a map on the  $\mathbb{Z}$ -quotients, which is precisely a map  $S_{\ell,\lambda}^{1|1} \rightarrow S_{\ell',\lambda'}^{1|1}$ . This map is locally determined by the action of  $\mathbb{E}^{1|1} \rtimes \mathbb{Z}/2$ , and hence respects the super Euclidean structures.  $\square$

### 2.2 Super Euclidean loop spaces

**Definition 2.10** The super Euclidean loop space is the generalized supermanifold

$$\mathcal{L}^{1|1}(M) := \mathbb{R}_{>0}^{1|1} \times \text{Map}(S^{1|1}, M).$$

We identify an  $S$ -point of  $\mathcal{L}^{1|1}(M)$  with a map  $S_{\ell,\lambda}^{1|1} \rightarrow M$  given by the composition

(31) 
$$S_{\ell,\lambda}^{1|1} \simeq S \times S^{1|1} \rightarrow M,$$

by pulling back the isomorphism from Lemma 2.8 along the map  $(\ell, \lambda): S \rightarrow \mathbb{R}_{>0}^{1|1}$ .

We will define a left action of  $\text{Euc}_{1|1}$  on  $\mathcal{L}^{1|1}(M)$  determined by the diagram

$$(32) \quad \begin{array}{ccc} S_{\ell,\lambda}^{1|1} & \xrightarrow{\cong} & S \times S^{1|1} & \xrightarrow{\phi} & M \\ f \downarrow & & & \nearrow \phi' & \\ S_{\ell',\lambda'}^{1|1} & \xrightarrow{\cong} & S \times S^{1|1} & & \end{array}$$

where the horizontal arrows are the pullback of the isomorphism in Lemma 2.8, and the super Euclidean isometry  $f$  is from Lemma 2.9 with  $(\ell', \lambda') = (\ell \pm 2\eta\lambda, \pm\lambda)$ . The arrow  $\phi'$  is uniquely determined by these isomorphisms and the input map  $\phi$ . Hence, given  $(\ell, \lambda, \phi) \in \mathbb{R}_{>0}^{1|1}(S) \times \text{Map}(S^{1|1}, M)(S)$  and an  $S$ -point of  $\text{Euc}_{1|1}$ , the  $\text{Euc}_{1|1}$ -action on  $\mathcal{L}^{1|1}(M)$  outputs  $(\ell', \lambda', \phi')$  as in (32).

**Remark 2.11** Precomposition actions (such as the action of  $\text{Euc}_{1|1}$  on  $\text{Map}(S^{1|1}, M)$  above) are most naturally right actions. Turning this into a left action involves inversion on the group: the formula for  $\phi'$  in (32) involves  $\phi$  and the *inverse* of  $f$ . This inversion introduces signs in the formulas for the left  $\text{Euc}_{1|1}$ -action on  $\mathcal{L}_0^{1|1}(M)$  below. Our choice to work with left actions is consistent with Freed’s conventions for classical supersymmetric field theories [15, pages 44–45]; see also [11, page 357].

There is an evident  $S^1$ -action on  $\mathcal{L}^{1|1}(M)$  coming from the precomposition action of  $S^1 = \mathbb{E}/\mathbb{Z} < \mathbb{E}^{1|1}/\mathbb{Z}$  on  $\text{Map}(S^{1|1}, M)$ . Since the quotient is given by  $S^{1|1}/S^1 \simeq \mathbb{R}^{0|1}$ , the  $S^1$ -fixed points are

$$(33) \quad \mathcal{L}_0^{1|1}(M) := \mathbb{R}_{>0}^{1|1} \times \text{Map}(\mathbb{R}^{0|1}, M) \subset \mathbb{R}_{>0}^{1|1} \times \text{Map}(S^{1|1}, M) = \mathcal{L}^{1|1}(M).$$

We identify an  $S$ -point of  $\mathcal{L}_0^{1|1}(M)$  with a map  $S_{\ell,\lambda}^{1|1} \rightarrow M$  that factors as

$$(34) \quad S_{\ell,\lambda}^{1|1} \simeq S \times S^{1|1} = S \times \mathbb{R}^{1|1}/\mathbb{Z} \xrightarrow{p} S \times \mathbb{R}^{0|1} \rightarrow M,$$

where the map  $p$  is induced by the projection  $\mathbb{R}^{1|1} \rightarrow \mathbb{R}^{0|1}$ . The action (32) preserves this factorization condition; we give an explicit formula in Lemma 2.13 below. Hence, the inclusion (33) is  $\text{Euc}_{1|1}$ -equivariant.

**Lemma 2.12** *There is a functor  $\mathcal{L}_0^{1|1}(M) \rightarrow 1|1\text{-EBord}(M)$  that induces a restriction map*

$$(35) \quad \text{restr}: 1|1\text{-EFT}(M) \rightarrow C^\infty(\mathcal{L}_0^{1|1}(M))^{\text{Euc}_{1|1}}.$$

**Proof** The 1|1-dimensional Euclidean bordism category over  $M$  is constructed by inputting the 1|1-dimensional Euclidean geometry from Definition 2.6 into the definition of a geometric bordism category [26, Definition 4.12]. The result is a category 1|1-EBord( $M$ ) internal to stacks on the site of supermanifolds; in particular, 1|1-EBord( $M$ ) has a stack of morphisms consisting of proper families of 1|1-dimensional Euclidean manifolds with a map to  $M$ , with additional decorations related to the source and target of a bordism.

By Lemma 2.7, super Euclidean circles give examples of  $S$ -families of 1|1-dimensional Euclidean manifolds. An  $S$ -point of  $\mathcal{L}_0^{1|1}(M)$  therefore defines a proper  $S$ -family of 1|1-Euclidean manifolds with a map to  $M$  via (34). We can identify this with an  $S$ -family of morphisms in 1|1-EBord( $M$ ) whose source and target are the empty supermanifold equipped with the unique map to  $M$ . This defines a functor  $\mathcal{L}_0^{1|1}(M) \rightarrow$  1|1-EBord( $M$ ) and a restriction map 1|1-EFT( $M$ )  $\rightarrow C^\infty(\mathcal{L}_0^{1|1}(M))$ . We refer to the discussion preceding [26, Definition 4.13] for an explanation why the restriction to closed bordisms extracts a function from a field theory.

Finally we argue that this restriction has image in  $\text{Euc}_{1|1}$ -invariant functions. By definition, an isometry between 1|1-dimensional Euclidean manifolds comes from the action of the super Euclidean group  $\text{Euc}_{1|1} = \mathbb{E}^{1|1} \rtimes \mathbb{Z}/2$  on the open cover defining the super Euclidean manifold. By Lemma 2.9, the action (32) on  $\mathcal{L}_0^{1|1}(M)$  is therefore through super Euclidean isometries of super circles compatible with the maps to  $M$ . By definition, these isometries define isomorphisms between the bordisms (34) in 1|1-EBord( $M$ ). Functions on a stack are functions on objects invariant under the action of isomorphisms. Hence, the restriction 1|1-EFT( $M$ )  $\rightarrow C^\infty(\mathcal{L}_0^{1|1}(M))$  necessarily takes values in functions invariant under  $\text{Euc}_{1|1}$ , yielding the claimed map (35). □

### 2.3 Computing the action of Euclidean isometries

**Lemma 2.13** *The left  $\text{Euc}_{1|1}$ -action on  $\mathbb{R}_{>0}^{1|1} \times \text{Map}(\mathbb{R}^{0|1}, M)$  is given by*

$$(36) \quad (s, \eta, \pm 1) \cdot (\ell, \lambda, x, \psi) = \left( \ell \pm 2i\eta\lambda, \pm\lambda, x \pm \left( \frac{\lambda s}{\ell} - \eta \right) \psi, \pm e^{-i\eta\lambda/\ell} \psi \right),$$

using notation for the functor of points,

$$(s, \eta, \pm 1) \in (\mathbb{E}^{1|1} \rtimes \mathbb{Z}/2)(S) \simeq \text{Euc}_{1|1}(S),$$

$$(\ell, \lambda) \in \mathbb{R}_{>0}^{1|1}(S),$$

$$(x, \psi) \in \text{PTM}(S) \simeq \text{Map}(\mathbb{R}^{0|1}, M)(S).$$

**Proof** Let  $p_{\ell,\lambda}: S_{\ell,\lambda}^{1|1} \rightarrow S \times \mathbb{R}^{0|1}$  denote the composition of the left three maps in (34). Given  $(s, \eta, \pm 1) \in \text{Euc}_{1|1}(S)$ ,  $(\ell, \lambda) \in \mathbb{R}_{>0}^{1|1}(S)$  and  $(x, \psi) \in \Pi TM(S) \simeq \text{Map}(\mathbb{R}^{0|1}, M)(S)$ , the goal of the lemma is to compute formulas for  $(\ell', \lambda') \in \mathbb{R}_{>0}^{1|1}(S)$  and  $(x', \psi') \in \Pi TM(S)$  in the diagram

$$(37) \quad \begin{array}{ccc} S_{\ell,\lambda}^{1|1} & \xrightarrow{p_{\ell,\lambda}} & S \times \mathbb{R}^{0|1} \\ f_{s,\eta,\pm 1} \downarrow & & \downarrow \\ S_{\ell',\lambda'}^{1|1} & \xrightarrow{p_{\ell',\lambda'}} & S \times \mathbb{R}^{0|1} \end{array} \begin{array}{c} \xrightarrow{(x,\psi)} \\ \xrightarrow{(x',\psi')} \end{array} M$$

where the arrow labeled by  $f_{s,\eta,\pm 1}$  denotes the isometry between super Euclidean circles from Lemma 2.9 for  $(s, \eta, \pm 1) \in \text{Euc}_{1|1}(S)$ . Hence, we see that  $(\ell', \lambda')$  is given by (29). To compute  $(x', \psi')$ , we find a formula for the dashed arrow in (37). To start, consider the map

$$\tilde{p}_{\ell,\lambda}: \mathbb{R}^{1|1} \times S \rightarrow \mathbb{R}^{0|1} \times S, \quad \tilde{p}_{\ell,\lambda}(t, \theta) = \theta - \lambda \frac{t}{\ell},$$

which is part of the inverse to the isomorphism (28). Indeed, we check the  $\mathbb{Z}$ -invariance condition for the action (26),

$$\tilde{p}_{\ell,\lambda}(n \cdot (t, \theta)) = \tilde{p}_{\ell,\lambda}(n\ell + t + in\lambda\theta, n\lambda + \theta) = n\lambda + \theta - \lambda \frac{n\ell + t + in\lambda\theta}{\ell} = \theta - \lambda \frac{t}{\ell}.$$

Hence  $\tilde{p}_{\ell,\lambda}$  determines a map  $p_{\ell,\lambda}: S_{\ell,\lambda}^{1|1} \rightarrow S \times \mathbb{R}^{0|1}$ , which is the map in (37). From this we see that the dashed arrow in (37) is unique and determined by

$$\theta \mapsto \pm \left( \theta + \eta - \lambda \frac{s + i\eta\theta}{\ell} \right), \quad \text{with } (s, \eta, \pm 1) \in \text{Euc}_{1|1}(S), \theta \in \mathbb{R}^{0|1}(S).$$

The left action (32) is given by (see Remark 2.11 for an explanation of the signs)

$$(x + \theta\psi) \mapsto x \pm \left( \theta - \eta - \lambda \frac{-s - i\eta\theta}{\ell} \right) \psi = x \pm \left( \frac{\lambda s}{\ell} - \eta \right) \psi \pm \theta \left( 1 - i \frac{\eta\lambda}{\ell} \right) \psi,$$

which is the claimed formula for  $(x', \psi')$ . □

Just as  $\mathbb{R}$ -actions on ordinary manifolds are determined by flows of vector fields,  $\mathbb{E}^{1|1}$ -actions on supermanifolds are determined by the flow of an odd vector field. This comes from differentiating a left  $\mathbb{E}^{1|1}$ -action at zero and considering the action by the element  $Q$  of the super Lie algebra, using the notation from (24). Odd vector fields on supermanifolds are precisely odd derivations on their functions. We note the isomorphism

$$(38) \quad \begin{aligned} C^\infty(\mathcal{L}_0^{1|1}(M)) &\simeq C^\infty(\mathbb{R}_{>0}^{1|1} \times \text{Map}(\mathbb{R}^{0|1}, M)) \simeq C^\infty(\mathbb{R}_{>0}^{1|1}) \otimes \Omega^\bullet(M) \\ &\simeq C^\infty(\mathbb{R}_{>0})[\lambda] \otimes \Omega^\bullet(M), \end{aligned}$$

where (in an abuse of notation) we let  $\ell, \lambda \in C^\infty(\mathbb{R}_{>0}^{1|1})$  denote the coordinate functions associated with the universal family of super circles  $S = \mathbb{R}_{>0}^{1|1} \rightarrow \mathbb{R}_{>0}^{1|1} \subset \mathbb{R}^{1|1}$ . In the above, we used that

$$C^\infty(\text{Map}(\mathbb{R}^{0|1}, M)) \simeq \Omega^\bullet(M) \quad \text{and} \quad C^\infty(S \times T) \simeq C^\infty(S) \otimes C^\infty(T)$$

for supermanifolds  $S$  and  $T$  using the projective tensor product of Fréchet algebras; see for instance [20, Example 49]. Let  $\text{deg}: \Omega^\bullet(M) \rightarrow \Omega^\bullet(M)$  denote the (even) degree derivation determined by  $\text{deg}(\omega) = k\omega$  for  $\omega \in \Omega^k(M)$ .

**Lemma 2.14** *The left  $\mathbb{E}^{1|1}$ -action (36) on  $\mathcal{L}_0^{1|1}(M)$  is generated by the odd derivation*

$$(39) \quad \hat{Q} := 2i\lambda \frac{d}{d\ell} \otimes \text{id} - \text{id} \otimes d - i \frac{\lambda}{\ell} \otimes \text{deg}$$

*using the identification of functions (38), where  $d$  is the de Rham differential and  $\text{deg}$  is the degree derivation on differential forms.*

**Proof** We recall that right-invariant vector fields generate left actions, so that the infinitesimal action of  $\mathbb{E}^{1|1}$  on  $\mathcal{L}_0^{1|1}(M)$  is determined by the action of  $Q$ . Furthermore, minus the de Rham operator generates the left  $\mathbb{E}^{0|1}$ -action  $(x, \psi) \mapsto (x - \eta\psi, \psi)$  on  $\Pi TM$ , and minus the degree derivation generates the left  $\mathbb{R}^\times$ -action  $(x, \psi) \mapsto (x, u^{-1}\psi)$ ; see eg [19, Section 3.4]. Applying the derivation  $Q = \partial_\eta + i\eta\partial_s$  to (36) and evaluating at  $(s, \eta) = 0$  recovers (39). □

## 2.4 The proof of Proposition 1.4

The  $\text{Euc}_{1|1}$ -equivariant inclusion

$$\mathbb{R}_{>0} \times \text{Map}(\mathbb{R}^{0|1}, M) \hookrightarrow \mathbb{R}_{>0}^{1|1} \times \text{Map}(\mathbb{R}^{0|1}, M) = \mathcal{L}_0^{1|1}(M)$$

is along  $S$ -families of super circles with  $\lambda = 0$ . So by Lemmas 2.13 and 2.14 we have

$$\begin{aligned} C^\infty(\mathbb{R}_{>0} \times \text{Map}(\mathbb{R}^{0|1}, M))^{\text{Euc}_{1|1}} &\simeq \Omega^\bullet(M; C^\infty(\mathbb{R}_{>0}))^{\mathbb{E}^{1|1} \rtimes \mathbb{Z}/2} \\ &\simeq \Omega_{\text{cl}}^{\text{ev}}(M; C^\infty(\mathbb{R}_{>0})) \end{aligned}$$

using (36) to see that  $\mathbb{Z}/2$  acts through the parity involution (so invariant functions are even forms) and (39) to see that the  $\mathbb{E}^{1|1}$ -action is generated by minus the de Rham  $d$  (so invariant functions are closed forms). This verifies the equality (17) when  $d = 1$  and extracts the data  $Z$  from an element of  $C^\infty(\mathcal{L}_0^{1|1}(M))^{\text{Euc}_{1|1}}$ .

Next, observe that

$$\begin{aligned} C^\infty(\mathcal{L}_0^{1|1}(M)) &\simeq C^\infty(\mathbb{R}_{>0}^{1|1} \times \text{Map}(\mathbb{R}^{0|1}, M)) \simeq \Omega^\bullet(M; C^\infty(\mathbb{R}_{>0}^{1|1})) \\ &\simeq \Omega^\bullet(M; C^\infty(\mathbb{R}_{>0})[\lambda]), \end{aligned}$$

where the final isomorphism comes from Taylor expansion of functions on  $\mathbb{R}_{>0}^{1|1}$  in the odd coordinate function  $\lambda$ . For convenience we choose the parametrization of functions

$$(40) \quad C^\infty(\mathcal{L}_0^{1|1}(M)) \simeq \{\ell^{\text{deg}/2}(Z + 2i\lambda\ell^{1/2}Z_\ell) \mid Z, Z_\ell \in \Omega^\bullet(M; C^\infty(\mathbb{R}_{>0}))\},$$

where  $\ell^{\text{deg}/2}\omega = \ell^{k/2}\omega$  for  $\omega \in \Omega^k(M; C^\infty(\mathbb{R}_{>0}))$ . We again have that  $\mathbb{Z}/2 < \text{Euc}_{1|1}$  acts by the parity involution, so since  $\lambda$  is odd and  $\ell$  is even we find

$$\begin{aligned} C^\infty(\mathcal{L}_0^{1|1}(M))^{\mathbb{Z}/2} &= \{\ell^{\text{deg}/2}(Z + 2i\lambda\ell^{1/2}Z_\ell) \mid Z \in \Omega^{\text{ev}}(M; C^\infty(\mathbb{R}_{>0})), Z_\ell \in \Omega^{\text{odd}}(M; C^\infty(\mathbb{R}_{>0}))\}. \end{aligned}$$

Next we compute

$$\begin{aligned} \widehat{Q}(\ell^{\text{deg}/2}Z + 2i\lambda\ell^{1/2}\ell^{\text{deg}/2}Z_\ell) &= 2i\lambda \frac{d}{d\ell}(\ell^{\text{deg}/2}Z) - \ell^{-1/2}\ell^{\text{deg}/2}dZ - 2i\lambda\ell^{\text{deg}/2}dZ_\ell - i\frac{\lambda}{\ell}\ell^{\text{deg}/2}\text{deg}(Z) \\ &= -\ell^{-1/2}\ell^{\text{deg}/2}dZ + 2i\lambda\ell^{\text{deg}/2}\left(\frac{dZ}{d\ell} - dZ_\ell\right), \end{aligned}$$

where in the first equality we use that  $d(\ell^{\text{deg}/2}\omega) = \ell^{-1/2}\ell^{\text{deg}/2}(d\omega)$ , and in the second equality we expand

$$2i\lambda \frac{d}{d\ell}(\ell^{\text{deg}/2}Z)$$

using the product rule and then simplify. Hence

$$(41) \quad \widehat{Q}(\ell^{\text{deg}/2}(Z + 2i\lambda\ell^{1/2}Z_\ell)) = 0 \iff dZ = 0 \text{ and } dZ_\ell = \frac{dZ}{d\ell}.$$

By Lemma 2.14,  $\widehat{Q}$  generates the  $\mathbb{E}^{1|1}$ -action and, since  $\mathbb{E}^{1|1}$  is connected,  $\widehat{Q}$ -invariant functions are equivalent to  $\mathbb{E}^{1|1}$ -invariant functions. Finally, we identify even differential forms with elements of  $\Omega^\bullet(M; C^\infty(\mathbb{R}_{>0})[\beta, \beta^{-1}])$  of total degree zero and odd differential forms with elements of  $\Omega^\bullet(M; C^\infty(\mathbb{R}_{>0})[\beta, \beta^{-1}])$  of total degree  $-1$  (essentially replacing  $\ell$  in (40) by  $\beta$ ). This completes the proof of Proposition 1.4.

### 2.5 Concordance classes of functions

For Proposition 1.2 we require a refinement of the cocycle map.

**Definition 2.15** Using the notation from Proposition 1.4, for each  $\mu \in \mathbb{R}_{>0}$  define a map

$$\widehat{\text{cocycle}}_\mu : C^\infty(\mathcal{L}_0^{1|1}(M))^{\text{Euc}_{1|1}} \rightarrow (\Omega_{\text{cl}}^\bullet(M; \mathbb{C}[\beta, \beta^{-1}]))^0,$$

$$\widehat{\text{cocycle}}_\mu(Z, Z_\ell) = Z(\mu),$$

where  $Z(\mu)$  denotes evaluation at  $\mu \in \mathbb{R}_{>0}$  and  $(\Omega_{\text{cl}}^\bullet(M; \mathbb{C}[\beta, \beta^{-1}]))^0$  is the space of closed differential forms of total degree zero.

**Lemma 2.16** *The composition*

$$C^\infty(\mathcal{L}_0^{1|1}(M))^{\text{Euc}_{1|1}} \xrightarrow{\widehat{\text{cocycle}}_\mu} (\Omega_{\text{cl}}^\bullet(M; \mathbb{C}[\beta, \beta^{-1}]))^0 \xrightarrow{\text{de Rham}} H(M; \mathbb{C}[\beta, \beta^{-1}])$$

agrees with (3) and hence is independent of  $\mu$ .

**Proof** The calculation (20) shows

$$[\widehat{\text{cocycle}}_\mu(Z, Z_\ell)] = [Z(\mu)] = [Z] = \text{cocycle}(Z, Z_\ell) \in H(M; \mathbb{C}[\beta, \beta^{-1}])$$

$$\subset H(M; C^\infty(\mathbb{R}_{>0})[\beta, \beta^{-1}]).$$

In particular, the class underlying  $\widehat{\text{cocycle}}_\mu(Z, Z_\ell)$  is independent of  $\mu$ . □

**Proof of Proposition 1.2 for  $d = 1$**  Proposition 1.4 implies  $M \mapsto C^\infty(\mathcal{L}_0^{1|1}(M))^{\text{Euc}_{1|1}}$  is a sheaf on the site of smooth manifolds. The map in Definition 2.15 is a morphism of sheaves

$$(42) \quad \widehat{\text{cocycle}}_\mu : C^\infty(\mathcal{L}_0^{1|1}(-))^{\text{Euc}_{1|1}} \rightarrow \Omega_{\text{cl}}^{\text{ev}}(-; \mathbb{C}[\beta, \beta^{-1}])$$

taking values in closed forms of even degree. By Stokes’ theorem, concordance classes of closed forms on a manifold  $M$  are cohomology classes. Hence, taking concordance classes of the map (42) applied to a manifold  $M$  proves the proposition when  $d = 1$ . □

## 2.6 The Chern character of a super connection

A *super connection*  $\mathbb{A}$  on a  $\mathbb{Z}/2$ -graded vector bundle  $V \rightarrow M$  is an odd  $\mathbb{C}$ -linear map satisfying the Leibniz rule [22]

$$\mathbb{A} : \Omega^\bullet(M; V) \rightarrow \Omega^\bullet(M; V), \quad \mathbb{A}(fs) = df \cdot s + (-1)^{|f|} f \mathbb{A}s,$$

for  $f \in \Omega^\bullet(M)$  and  $s \in \Omega^\bullet(M; V)$ . One can express a super connection as a finite sum  $\mathbb{A} = \sum_j \mathbb{A}_j$ , where  $\mathbb{A}_j : \Omega^\bullet(M; V) \rightarrow \Omega^{\bullet+j}(M; V)$  raises differential form degree by  $j$ . Note that  $\mathbb{A}_1$  is an ordinary connection on  $V$ , and  $\mathbb{A}_j$  is a differential form valued



in  $\text{End}(V)^{\text{odd}}$  if  $j$  is even and  $\text{End}(V)^{\text{ev}}$  if  $j$  is odd. *Super parallel transport* provides a functor, denoted by  $\text{sPar}$ , from the groupoid of  $\mathbb{Z}/2$ -graded vector bundles with super connection on  $M$  to the groupoid of 1|1-dimensional Euclidean field theories over  $M$ :

$$(43) \quad \begin{aligned} \text{Vect}^{\mathbb{A}}(M) &\xrightarrow{\text{sPar}} 1|1\text{-EFT}(M) \xrightarrow{\text{res}} C^\infty(\mathbb{R}_{>0} \times \text{Map}(\mathbb{R}^{0|1}, M))^{\text{Euc}_{1|1}}, \\ (V, \mathbb{A}) &\longmapsto \text{sPar}(V, \mathbb{A}) \longmapsto \text{sTr}(e^{\ell \mathbb{A}^2}). \end{aligned}$$

Part of this construction is given in [14], reviewed in [26, Section 1.3]. A different approach (satisfying stronger naturality properties required to construct the functor  $\text{sPar}$ ) is work in progress by Arnold [2]. Evaluating the field theory  $\text{sPar}(V, \mathbb{A})$  on closed bordisms determines the function  $\text{sTr}(e^{\ell \mathbb{A}^2}) \in C^\infty(\mathbb{R}_{>0} \times \text{Map}(\mathbb{R}^{0|1}, M))$ . The parametrization (40) extracts the function  $Z$  determined by

$$\ell^{\text{deg}/2} Z = \text{sTr}(\exp(\ell \mathbb{A}^2)).$$

Hence we find that  $Z = \text{sTr}(\exp(\mathbb{A}_\ell^2))$  for

$$(44) \quad \mathbb{A}_\ell = \ell^{1/2} \mathbb{A}_0 + \mathbb{A}_1 + \ell^{-1/2} \mathbb{A}_2 + \ell^{-1} \mathbb{A}_3 + \dots$$

The  $\mathbb{R}_{>0}$ -family of super connections (44) appears frequently in index theory, eg [22] and [4, Section 9.1]. By [4, Proposition 1.41], the failure for  $Z$  to be independent of  $\ell$  is measured by the exact form

$$(45) \quad \frac{d}{d\ell} \text{sTr}(e^{\mathbb{A}_\ell^2}) = d\left(\text{sTr}\left(\frac{d\mathbb{A}_\ell}{dt} e^{\mathbb{A}_\ell^2}\right)\right).$$

By Proposition 1.4, the data  $Z = \text{sTr}(e^{\mathbb{A}_\ell^2})$  and  $Z_\ell = \text{sTr}((d\mathbb{A}_\ell/dt)e^{\mathbb{A}_\ell^2})$  determine an element of  $C^\infty(\mathcal{L}_0^{1|1}(M))^{\text{Euc}_{1|1}}$  refining the Chern character of the  $\mathbb{Z}/2$ -graded vector bundle  $V$ .

**Remark 2.17** If  $\mathbb{A} = \nabla$  is an ordinary connection, the family (44) is independent of  $\ell$  and  $Z_\ell = 0$ . This recovers Fei Han’s identification [18] of the Chern form  $\text{Tr}(\exp(\nabla^2))$  with dimensional reduction of the 1|1-dimensional Euclidean field theory  $\text{sPar}(V, \nabla)$ .

### 3 A map from 2|1-Euclidean field theories to complexified elliptic cohomology

The main goal of this section is to prove Proposition 1.5. From the discussion in Section 1.2, this proves Theorem 1.1 when  $d = 2$ . We also prove Proposition 1.2 when  $d = 2$  and comment on connections with a de Rham model for complex-analytic elliptic cohomology, complexified TMF, and elliptic Euler classes.

### 3.1 The moduli space of super Euclidean tori

We will use the two equivalent descriptions of  $S$ -points of  $\mathbb{R}^{2|1}$ :

$$(46) \quad \mathbb{R}^{2|1}(S) \simeq \{x, y \in C^\infty(S)^{\text{ev}}, \theta \in C^\infty(S)^{\text{odd}} \mid (x)_{\text{red}} = (\overline{x})_{\text{red}}, (y)_{\text{red}} = (\overline{y})_{\text{red}}\}$$

$$(47) \quad \simeq \{z, w \in C^\infty(S)^{\text{ev}}, \theta \in C^\infty(S)^{\text{odd}} \mid (z)_{\text{red}} = (\overline{w})_{\text{red}}\},$$

where reality conditions are imposed on restriction of functions to the reduced manifold  $S_{\text{red}} \hookrightarrow S$ . The isomorphism between (46) and (47) is  $(x, y) \mapsto (x + iy, x - iy) = (z, w)$ . Below we shall adopt the standard (though potentially misleading) notation  $\overline{z} := w$ . We take similar notation for  $S$ -points of  $\text{Spin}(2)$ , using the identification  $\text{Spin}(2) \simeq U(1) \subset \mathbb{C}$  with the unit complex numbers. This gives the description

$$(48) \quad \text{Spin}(2)(S) \simeq U(1)(S) = \{u, \overline{u} \in C^\infty(S)^{\text{ev}} \mid (u)_{\text{red}} = (\overline{u})_{\text{red}}, u\overline{u} = 1\}.$$

**Definition 3.1** Let  $\mathbb{E}^{2|1}$  denote the super Lie group with underlying supermanifold  $\mathbb{R}^{2|1}$  and multiplication

$$(49) \quad (z, \overline{z}, \theta) \cdot (z', \overline{z}', \theta') = (z + z', \overline{z} + \overline{z}' + \theta\theta', \theta + \theta')$$

for  $(z, \overline{z}, \theta), (z', \overline{z}', \theta') \in \mathbb{R}^{2|1}(S)$ . Define the *super Euclidean group* as  $\mathbb{E}^{2|1} \rtimes \text{Spin}(2)$ , where the semidirect product is defined by the action (using the notation (48))

$$(u, \overline{u}) \cdot (z, \overline{z}, \theta) = (u^2 z, \overline{u}^2 \overline{z}, \overline{u}\theta) \quad \text{for } (u, \overline{u}) \in \text{Spin}(2)(S).$$

The Lie algebra of  $\mathbb{E}^{2|1}$  has one even generator and one odd generator. In terms of left-invariant vector fields, these are  $\partial_z$  and  $D = \partial_\theta - \theta\partial_{\overline{z}}$ , whereas in terms of right-invariant vector fields they are  $\partial_z$  and  $Q = \partial_\theta + \theta\partial_{\overline{z}}$ . The super commutators are

$$(50) \quad [\partial_z, D] = 0, [D, D] = -\partial_{\overline{z}} \quad \text{and} \quad [\partial_z, Q] = 0, [Q, Q] = \partial_{\overline{z}}.$$

Let  $\text{Lat} \subset \mathbb{C} \times \mathbb{C}$  denote the manifold of *based lattices* in  $\mathbb{C}$  parametrizing pairs of nonzero complex numbers  $\ell_1, \ell_2 \in \mathbb{C}^\times$  such that  $\ell_1/\ell_2 \in \mathbb{H} \subset \mathbb{C}$  is in the upper half-plane. Equivalently, the pair  $(\ell_1, \ell_2)$  generate a based oriented lattice in  $\mathbb{C}$ . We observe that  $(\ell_1, \ell_2) \mapsto (\ell_1, \ell_1/\ell_2)$  defines a diffeomorphism  $\text{Lat} \simeq \mathbb{C}^\times \times \mathbb{H}$ , so that  $\text{Lat}$  is indeed a manifold. When regarding  $\text{Lat}$  as a supermanifold, an  $S$ -point is specified by  $(\ell_1, \overline{\ell}_1, \ell_2, \overline{\ell}_2) \in \text{Lat}(S) \subset (\mathbb{C} \times \mathbb{C})(S)$ , following the notation from (47).

**Definition 3.2** Define the generalized supermanifold of *based (super) lattices* in  $\mathbb{R}^{2|1}$  as the subfunctor  $s\text{Lat} \subset \mathbb{R}^{2|1} \times \mathbb{R}^{2|1}$  (viewing  $\mathbb{R}^{2|1} \times \mathbb{R}^{2|1}$  as a representable presheaf) whose  $S$ -points are  $(\ell_1, \overline{\ell}_1, \lambda_1), (\ell_2, \overline{\ell}_2, \lambda_2) \in \mathbb{R}^{2|1}(S)$  such that:

(i) The pair commute for the multiplication (49) on  $\mathbb{E}^{2|1}(S) \simeq \mathbb{R}^{2|1}(S)$ ,

$$(\ell_1, \bar{\ell}_1, \lambda_1) \cdot (\ell_2, \bar{\ell}_2, \lambda_2) = (\ell_2, \bar{\ell}_2, \lambda_2) \cdot (\ell_1, \bar{\ell}_1, \lambda_1) \in \mathbb{E}^{2|1}(S).$$

(ii) The reduced map  $S_{\text{red}} \rightarrow (\mathbb{R}^{2|1} \times \mathbb{R}^{2|1})_{\text{red}} \simeq \mathbb{R}^2 \times \mathbb{R}^2 \simeq \mathbb{C} \times \mathbb{C}$  determines a family of based oriented lattices in  $\mathbb{C}$ , ie the image lies in  $\text{Lat} \subset \mathbb{C} \times \mathbb{C}$ .

**Remark 3.3** Condition (i) is equivalent to requiring that  $(\ell_1, \bar{\ell}_1, \lambda_1), (\ell_2, \bar{\ell}_2, \lambda_2) \in \mathbb{E}^{2|1}(S)$  generate a  $\mathbb{Z}^2$ -subgroup, ie a homomorphism  $S \times \mathbb{Z}^2 \rightarrow S \times \mathbb{E}^{2|1}$  over  $S$ .

**Definition 3.4** Given an  $S$ -point  $\Lambda = ((\ell_1, \bar{\ell}_1, \lambda_1), (\ell_2, \bar{\ell}_2, \lambda_2)) \in s\text{Lat}(S)$ , define the family of  $2|1$ -dimensional *super tori* as the quotient

$$(51) \quad T_\Lambda^{2|1} := (S \times \mathbb{R}^{2|1}) / \mathbb{Z}^2$$

for the free left  $\mathbb{Z}^2$ -action over  $S$  determined by the formula

$$(52) \quad (n, m) \cdot (z, \bar{z}, \theta) = (z + n\ell_1 + m\ell_2, \bar{z} + n\bar{\ell}_1 + \lambda_1\theta + m\bar{\ell}_2 + \lambda_2\theta), n\lambda_1 + m\lambda_2 + \theta)$$

for  $(n, m) \in \mathbb{Z}^2(S)$  and  $(z, \bar{z}, \theta) \in \mathbb{R}^{2|1}(S)$ . Equivalently, this is the restriction of the left  $\mathbb{E}^{2|1}$ -action on  $S \times \mathbb{R}^{2|1}$  to the  $S$ -family of subgroups  $S \times \mathbb{Z}^2 \subset S \times \mathbb{E}^{2|1}$  with generators over  $S$  specified by  $(\ell_1, \bar{\ell}_1, \lambda_1)$  and  $(\ell_2, \bar{\ell}_2, \lambda_2)$ . Define the *standard super torus* as  $T^{2|1} = \mathbb{R}^{2|1} / \mathbb{Z}^2$  for the quotient by the action for the standard inclusion  $\mathbb{Z}^2 \subset \mathbb{R}^2 \subset \mathbb{E}^{2|1}$ , ie for the square lattice.

**Remark 3.5** The  $S$ -family of subgroups  $S \times \mathbb{Z}^2 \hookrightarrow S \times \mathbb{E}^{2|1}$  determined by  $\Lambda$  (as in Remark 3.3) is normal if and only if  $\lambda_1 = \lambda_2 = 0$ . Hence, although the standard super torus  $T^{2|1}$  inherits a group structure from  $\mathbb{E}^{2|1}$ , generic super tori  $T_\Lambda^{2|1}$  do not.

**Remark 3.6** There is a more general notion of a family of super tori where the action (52) also incorporates pairs of elements in  $\text{Spin}(2)$ . This moduli space has connected components corresponding to choices of spin structure on an ordinary torus, with the component from Definition 3.4 corresponding to the odd (or periodic-periodic) spin structure. This turns out to be the relevant component of the moduli space to recover complex-analytic elliptic cohomology.

Stolz and Teichner’s  $(\mathbb{M}, G)$ -structures are discussed before Definition 2.6.

**Definition 3.7** [26, Section 4.2] A *super Euclidean* structure on a  $2|1$ -dimensional family  $T \rightarrow S$  is an  $(\mathbb{M}, G)$ -structure for the left action of  $G = \mathbb{E}^{2|1} \rtimes \text{Spin}(2)$  on  $\mathbb{M} = \mathbb{R}^{2|1}$ .

**Lemma 3.8** *An  $S$ -family of super tori (51) has a canonical super Euclidean structure.*

**Proof** The proof is the same as for Lemma 2.7, using the open cover  $S \times \mathbb{R}^{2|1} \rightarrow T_{\Lambda}^{2|1}$  and transition data from the  $\mathbb{Z}^2$ -action (52). □

Every family of super tori pulls back from the universal family  $(s\text{Lat} \times \mathbb{R}^{2|1})/\mathbb{Z}^2 \rightarrow s\text{Lat}$  along a map  $S \rightarrow s\text{Lat}$ . Hence, we regard

$$\mathcal{M}^{2|1} := s\text{Lat} \quad \text{and} \quad \mathcal{T}^{2|1} := (s\text{Lat} \times \mathbb{R}^{2|1})/\mathbb{Z}^2 \rightarrow s\text{Lat}$$

as the moduli space of super Euclidean tori and the universal family of super Euclidean tori, respectively. The following identifies  $s\text{Lat}$  with the moduli space of super Euclidean structures on the standard super torus.

**Lemma 3.9** *There exists an isomorphism of supermanifolds over  $s\text{Lat}$ ,*

$$(53) \quad s\text{Lat} \times T^{2|1} \xrightarrow{\sim} \mathcal{T}^{2|1},$$

*from the constant  $s\text{Lat}$ -family with fiber the standard super torus to the universal family of super Euclidean tori. This isomorphism does not preserve the super Euclidean structure on  $\mathcal{T}^{2|1}$ .*

**Proof** Define the map  $s\text{Lat} \times \mathbb{R}^{2|1} \rightarrow s\text{Lat} \times \mathbb{R}^{2|1}$  by

$$(54) \quad (\ell_1, \bar{\ell}_1, \lambda_1, \ell_2, \bar{\ell}_2, \lambda_2, x, y, \theta) \\ \mapsto (\ell_1, \bar{\ell}_1, \lambda_1, \ell_2, \bar{\ell}_2, \lambda_2, \ell_1 x + \ell_2 y, x(\bar{\ell}_1 + \lambda_1 \theta) + y(\bar{\ell}_2 + \lambda_2 \theta), \theta + x\lambda_1 + y\lambda_2)$$

for  $(\ell_1, \bar{\ell}_1, \lambda_1, \ell_2, \bar{\ell}_2, \lambda_2) \in s\text{Lat}(S)$  and  $(x, y, \theta) \in \mathbb{R}^{2|1}(S)$ , where the source uses (46) to specify an  $S$ -point  $(x, y, \theta) \in \mathbb{R}^{2|1}(S)$  whereas the target uses (47). Observe that (54) is  $\mathbb{Z}^2$ -equivariant for the actions on the source and target,

$$(n, m) \cdot (\ell_1, \bar{\ell}_1, \lambda_1, \ell_2, \bar{\ell}_2, \lambda_2, x, y, \theta) = (\ell_1, \bar{\ell}_1, \lambda_1, \ell_2, \bar{\ell}_2, \lambda_2, x + n, y + m, \theta)$$

and

$$(n, m) \cdot (\ell_1, \bar{\ell}_1, \lambda_1, \ell_2, \bar{\ell}_2, \lambda_2, z, \bar{z}, \theta) \\ = (\ell_1, \bar{\ell}_1, \lambda_1, \ell_2, \bar{\ell}_2, \lambda_2, z + n\ell_1 + m\ell_2, \bar{z} + n(\bar{\ell}_1 + \lambda_1 \theta) + m(\bar{\ell}_2 + \lambda_2 \theta), \theta + n\lambda_1 + m\lambda_2),$$

respectively. Hence (54) determines a map between the respective  $\mathbb{Z}^2$ -quotients, defining a map (53). This map is easily seen to be an isomorphism of supermanifolds. Since the map (53) is not locally determined by the action of  $\mathbb{E}^{2|1} \rtimes \text{Spin}(2)$  on  $\mathbb{R}^{2|1}$ , it is not a super Euclidean isometry. □

**Definition 3.10** Define the super Lie group  $\text{Euc}_{2|1} := \mathbb{E}^{2|1} \rtimes \text{Spin}(2) \times \text{SL}_2(\mathbb{Z})$ .

The following gives an  $S$ -point formula for the action of  $\text{Euc}_{2|1}$  on  $\mathcal{T}^{2|1}$  and  $\mathcal{M}^{2|1} = s\text{Lat}$  coming from isometries between super Euclidean tori.

**Lemma 3.11** *Given  $\Lambda = ((\ell_1, \bar{\ell}_1, \lambda_1), (\ell_2, \bar{\ell}_2, \lambda_2)) \in s\text{Lat}(S) = \mathcal{M}^{2|1}(S)$  together with  $(w, \bar{w}, \eta, u, \bar{u}) \in (\mathbb{E}^{2|1} \rtimes \text{Spin}(2))(S)$  and  $\gamma \in \text{SL}_2(\mathbb{Z})(S)$ , there is an isomorphism  $f_{(w, \bar{w}, \eta, u, \bar{u})}: T_{\Lambda}^{2|1} \rightarrow T_{\Lambda'}^{2|1}$  of super Euclidean tori over  $S$  sitting in the diagram*

$$\begin{CD} S \times \mathbb{R}^{2|1} @>(w, \bar{w}, \eta, u, \bar{u})>> S \times \mathbb{R}^{2|1} \\ @VVV @VVV \\ T_{\Lambda}^{2|1} @>f_{(w, \bar{w}, \eta, u, \bar{u})}>> T_{\Lambda'}^{2|1} \end{CD}$$

where the upper horizontal arrow is determined by the left  $\mathbb{E}^{2|1} \rtimes \text{Spin}(2)$ -action on  $\mathbb{R}^{2|1}$ , the left vertical arrow is the quotient map (25) for  $\Lambda$ , and the right vertical arrow is the quotient map for

$$(55) \quad \Lambda' := \left( \left( u^2(al_1 + bl_2), \bar{u}^2(a\bar{\ell}_1 + 2\eta\lambda_1) + b(\bar{\ell}_2 + 2\eta\lambda_2), \bar{u}(a\lambda_1 + b\lambda_2) \right), \left( u^2(cl_1 + dl_2), \bar{u}^2(c\bar{\ell}_1 + 2\eta\lambda_1) + d(\bar{\ell}_2 + 2\eta\lambda_2), \bar{u}(c\lambda_1 + d\lambda_2) \right) \right),$$

where  $\gamma = \begin{bmatrix} a & b \\ c & d \end{bmatrix} \in \text{SL}_2(\mathbb{Z})(S)$ .

**Proof** Consider the diagram

$$(56) \quad \begin{CD} \mathbb{Z}^2 \times S \times \mathbb{R}^{2|1} @>\gamma \times (w, \bar{w}, \eta, u, \bar{u})>> \mathbb{Z}^2 \times S \times \mathbb{R}^{2|1} \\ @V\Lambda VV @VV\Lambda' V \\ S \times \mathbb{R}^{2|1} @>(w, \bar{w}, \eta, u, \bar{u})>> S \times \mathbb{R}^{2|1} \end{CD}$$

The horizontal arrows are determined by the left action of  $(w, \bar{w}, \eta) \in \mathbb{E}^{2|1}(S)$ ,  $(u, \bar{u}) \in \text{Spin}(2)(S)$  on  $S \times \mathbb{R}^{2|1}$  and a map  $S \times \mathbb{Z}^2 \rightarrow S \times \mathbb{Z}^2$  specified by  $\gamma \in \text{SL}_2(\mathbb{Z})(S)$ . The vertical arrows are the  $\mathbb{Z}^2$ -action on  $S \times \mathbb{R}^{2|1}$  generated by  $\Lambda, \Lambda' \in s\text{Lat}(S)$ . Using (49), this square commutes if and only if (55) holds. Commutativity of (56) gives a map on the  $\mathbb{Z}^2$ -quotients, which is precisely a map  $T_{\Lambda}^{2|1} \rightarrow T_{\Lambda'}^{2|1}$ . This map is locally given by the action of  $\mathbb{E}^{2|1} \rtimes \text{Spin}(2)$  on  $\mathbb{R}^{2|1}$ , so by construction it respects the super Euclidean structures. □

We will require an explicit description of functions on  $s\text{Lat}$ , ie the morphisms of presheaves  $s\text{Lat} \rightarrow C^\infty$ . Regarding  $\text{Lat}$  as a representable presheaf on supermanifolds, there is an evident monomorphism  $\text{Lat} \hookrightarrow s\text{Lat}$  from the canonical inclusion  $\mathbb{C} \times \mathbb{C} \simeq \mathbb{R}^2 \times \mathbb{R}^2 \hookrightarrow \mathbb{R}^{2|1} \times \mathbb{R}^{2|1}$ . In the following, let  $\lambda_1, \lambda_2 \in C^\infty(s\text{Lat})$  denote the restriction of the odd coordinate functions  $C^\infty(\mathbb{R}^{2|1} \times \mathbb{R}^{2|1}) \simeq C^\infty(\mathbb{R}^4)[\lambda_1, \lambda_2]$  under the inclusion  $s\text{Lat} \subset \mathbb{R}^{2|1} \times \mathbb{R}^{2|1}$ .

**Lemma 3.12** *There is an isomorphism of algebras*

$$C^\infty(s\text{Lat}) \simeq C^\infty(\text{Lat})[\lambda_1, \lambda_2]/(\lambda_1\lambda_2).$$

**Proof** Consider the composition

$$S \rightarrow s\text{Lat} \subset \mathbb{R}^{2|1} \times \mathbb{R}^{2|1} \xrightarrow{p_1, p_2} \mathbb{R}^{2|1},$$

where, as usual, we write the associated pair of maps  $S \rightarrow \mathbb{R}^{2|1}$  as  $(\ell_1, \bar{\ell}_1, \lambda_1)$  and  $(\ell_2, \bar{\ell}_2, \lambda_2)$ . We therefore have 4 even and 2 odd functions on  $s\text{Lat}$  that, as maps of sheaves  $s\text{Lat} \rightarrow C^\infty$ , assign to an  $S$ -point the functions  $\ell_1, \bar{\ell}_1, \ell_2, \bar{\ell}_2 \in C^\infty(S)^{\text{ev}}$  or  $\lambda_1, \lambda_2 \in C^\infty(S)^{\text{odd}}$ . It is easy to see that arbitrary smooth functions in the variables  $\ell_1, \bar{\ell}_1, \ell_2, \bar{\ell}_2$  continue to define maps of sheaves and hence smooth functions on  $s\text{Lat}$ . Furthermore, since these are the restriction of functions on  $\mathbb{R}^2 \times \mathbb{R}^2 \subset \mathbb{R}^{2|1} \times \mathbb{R}^{2|1}$ , we can identify them with functions on  $\text{Lat}$ . This specifies the even subalgebra  $C^\infty(\text{Lat}) \subset C^\infty(s\text{Lat})$ . On the other hand, the odd functions  $\lambda_1$  and  $\lambda_2$  are subject to a relation coming from condition (i) in Definition 3.2, namely that  $\lambda_1\lambda_2 = \lambda_2\lambda_1 \in C^\infty(S)^{\text{odd}}$  for all  $S$ . Since these are odd functions, this is equivalent to the condition that  $\lambda_1\lambda_2 = 0$ . Hence the functions on  $s\text{Lat}$  are as claimed.  $\square$

**Remark 3.13** The relation  $\lambda_1\lambda_2 = 0$  implies that  $C^\infty(s\text{Lat})$  is not the algebra of functions on any supermanifold, and hence the generalized supermanifold  $s\text{Lat}$  fails to be representable.

### 3.2 Super Euclidean double loop spaces

**Definition 3.14** Define the *super Euclidean double loop space* as the generalized supermanifold

$$\mathcal{L}^{2|1}(M) := s\text{Lat} \times \text{Map}(T^{2|1}, M).$$

We identify an  $S$ -point of  $\mathcal{L}^{2|1}(M)$  with a map  $T_\Lambda^{2|1} \rightarrow M$  given by the composition

$$(57) \quad T_\Lambda^{2|1} \simeq S \times T^{2|1} \rightarrow M,$$

using the isomorphism from Lemma 3.9.

We shall define a left action of  $\text{Euc}_{2|1}$  on  $\mathcal{L}^{2|1}(M)$  determined by the diagram

$$(58) \quad \begin{array}{ccc} T_\Lambda^{2|1} & \xrightarrow{\cong} & S \times T^{2|1} & \xrightarrow{\phi} & M \\ f \downarrow & & & \nearrow \text{---} & \\ T_{\Lambda'}^{2|1} & \xrightarrow{\cong} & S \times T^{2|1} & \xrightarrow{\phi'} & M \end{array}$$

where the horizontal arrows are the inverses of the isomorphisms of supermanifolds pulled back from Lemma 3.9, and  $f$  is the super Euclidean isometry associated to an  $S$ -point of  $\text{Euc}_{2|1}$  in Lemma 3.11. These isomorphisms together with the arrow  $\phi$  uniquely determine  $\phi'$  in (58). Hence, for  $(\Lambda, \phi) \in s\text{Lat}(S) \times \text{Map}(T^{2|1}, M)(S)$  and an  $S$ -point of  $\text{Euc}_{2|1}$ , we define the  $\text{Euc}_{2|1}$ -action on  $\mathcal{L}^{2|1}(M)$  as outputting  $(\Lambda', \phi')$  in (58). We caution that this is a left  $\text{Euc}_{2|1}$ -action on  $s\text{Lat} \times \text{Map}(T^{2|1}, M)$ , and refer to Remark 2.11 for a discussion of left actions on mapping spaces.

There is a  $T^2$ -action on  $\mathcal{L}^{2|1}(M)$  coming from the  $T^2$ -action on  $\text{Map}(T^{2|1}, M)$  by the precomposition action of  $T^2$  on  $T^{2|1}$ . The  $T^2$ -fixed points comprise the subspace

$$(59) \quad \mathcal{L}_0^{2|1}(M) := s\text{Lat} \times \text{Map}(\mathbb{R}^{0|1}, M) \subset s\text{Lat} \times \text{Map}(T^{2|1}, M) = \mathcal{L}^{2|1}(M).$$

We identify an  $S$ -point of this subspace as a map  $T_\Lambda^{2|1} \rightarrow M$  that factors as

$$(60) \quad T_\Lambda^{2|1} \simeq S \times T^{2|1} \simeq S \times \mathbb{R}^{2|1} / \mathbb{Z}^2 \xrightarrow{p} S \times \mathbb{R}^{0|1} \rightarrow M,$$

where the map  $p$  is induced by the projection  $\mathbb{R}^{2|1} \rightarrow \mathbb{R}^{0|1}$ . The action (58) preserves this factorization condition; we give explicit formulae in Lemma 3.17 below. Hence, the inclusion (59) is  $\text{Euc}_{2|1}$ -equivariant.

**Lemma 3.15** *There is a functor  $\mathcal{L}_0^{2|1}(M) \rightarrow 2|1\text{-EBord}(M)$  that induces a restriction map*

$$(61) \quad \text{restr}: 2|1\text{-EFT}(M) \rightarrow C^\infty(\mathcal{L}_0^{2|1}(M))^{\text{Euc}_{2|1}}.$$

**Proof** The proof is completely analogous to that of Lemma 2.12. Namely, Lemma 3.8 gives a functor  $\mathcal{L}_0^{2|1}(M) \rightarrow 2|1\text{-Bord}(M)$ , and Lemma 3.11 shows that the action of  $\text{Euc}_{2|1}$  on  $\mathcal{L}_0^{2|1}(M)$  is through isomorphisms between  $S$ -families of  $2|1$ -dimensional Euclidean bordisms. Hence, the restriction map lands in  $\text{Euc}_{2|1}$ -invariant functions.  $\square$

### 3.3 Computing the action of super Euclidean isometries

**Definition 3.16** Using the notation from Lemma 3.12, define the function

$$(62) \quad \text{vol} := \frac{\ell_1 \bar{\ell}_2 - \bar{\ell}_1 \ell_2}{2i} \in C^\infty(s\text{Lat}).$$

The restriction of  $\text{vol}$  along  $\text{Lat} \leftrightarrow s\text{Lat}$  is the function that reads off the volume of an ordinary torus  $\mathbb{C} / \ell_1 \mathbb{Z} \oplus \ell_2 \mathbb{Z}$  using the flat metric. In particular, this function is real-valued, positive and invertible. By Lemma 3.12, the function  $\text{vol}$  on  $s\text{Lat}$  is also invertible.

**Lemma 3.17** *The left  $\mathbb{E}^{2|1} \rtimes \text{Spin}(2)$ -action on  $s\text{Lat} \times \text{Map}(\mathbb{R}^{0|1}, M)$  is given by*

$$(63) \quad (w, \bar{w}, \eta, u, \bar{u}) \cdot (\ell_1, \bar{\ell}_1, \lambda_1, \ell_2, \bar{\ell}_2, \lambda_2, x, \psi) \\ = \left( u^2 \ell_1, \bar{u}^2 (\bar{\ell}_1 + 2\eta \lambda_1), \bar{u} \lambda_1, u^2 \ell_2, \bar{u}^2 (\bar{\ell}_2 + 2\eta \lambda_2), \bar{u} \lambda_2, \right. \\ \left. x - \bar{u}^{-1} \left( \eta + \frac{\lambda_1 \ell_2 - \lambda_2 \ell_1}{2i \text{vol}} \bar{w} + \frac{\lambda_1 \bar{\ell}_2 - \lambda_2 \bar{\ell}_1}{2i \text{vol}} w \right) \psi, \right. \\ \left. \bar{u}^{-1} \exp \left( \eta \frac{\lambda_1 \ell_2 - \lambda_2 \ell_1}{2i \text{vol}} \right) \psi \right),$$

where

$$(w, \bar{w}, \eta) \in \mathbb{E}^{2|1}(S), \quad (u, \bar{u}) \in \text{Spin}(2)(S), \\ (x, \psi) \in \Pi T M(S) \simeq \text{Map}(\mathbb{R}^{0|1}, M)(S).$$

The  $\text{SL}_2(\mathbb{Z})$ -action on  $s\text{Lat} \times \text{Map}(\mathbb{R}^{0|1}, M)$  is diagonal for the action on  $s\text{Lat}$  from (55) and the trivial action on  $\text{Map}(\mathbb{R}^{0|1}, M)$ .

**Proof** Let  $p_\Lambda : T_\Lambda^{2|1} \rightarrow S \times \mathbb{R}^{0|1}$  denote the composition of the left three maps in (60). Given  $(w, \bar{w}, \eta) \in \mathbb{E}^{2|1}(S)$ ,  $(u, \bar{u}) \in \text{Spin}(2)(S)$ ,  $\Lambda \in s\text{Lat}(S)$  and  $(x, \psi) \in \Pi T M(S)$ , the goal of the lemma is to compute formulas for  $\Lambda' \in s\text{Lat}(S)$  and  $(x', \psi') \in \Pi T M(S)$  in the diagram

$$(64) \quad \begin{array}{ccccc} T_\Lambda^{2|1} & \xrightarrow{p_\Lambda} & S \times \mathbb{R}^{0|1} & \xrightarrow{(x, \psi)} & M \\ f_{(w, \bar{w}, \eta, u, \bar{u})} \downarrow & & \downarrow & \searrow & \\ T_{\Lambda'}^{2|1} & \xrightarrow{p_{\Lambda'}} & S \times \mathbb{R}^{0|1} & \xrightarrow{(x', \psi')} & M \end{array}$$

where the arrow labeled by  $f_{(w, \bar{w}, \eta, u, \bar{u})}$  denotes the associated map between super Euclidean tori from Lemma 3.11. For the first statement in the present lemma we take  $\gamma = \text{id} \in \text{SL}_2(\mathbb{Z})(S)$ . We see that  $\Lambda'$  is given by (55). To compute  $(x', \psi')$ , we find a formula for the dashed arrow in (64) that makes the triangle commute. To start, part of the data of the inverse to the isomorphism (54) is

$$(65) \quad \tilde{p}_\Lambda : S \times \mathbb{R}^{2|1} \rightarrow S \times \mathbb{R}^{0|1}, \\ \tilde{p}_\Lambda(z, \bar{z}, \theta) = \theta + \lambda_1 \frac{\bar{z} \ell_2 - z \bar{\ell}_2}{2i \text{vol}} + \lambda_2 \frac{z \bar{\ell}_1 - \bar{z} \ell_1}{2i \text{vol}}.$$

We verify that  $\tilde{p}_\Lambda$  is  $\mathbb{Z}^2$ -invariant for the action (52),

$$\tilde{p}_{\ell, \lambda}((n, m) \cdot (z, \bar{z}, \theta)) \\ = \tilde{p}_{\ell, \lambda}(z + n \ell_1 + m \ell_2, \bar{z} + n \bar{\ell}_1 + \lambda_1 \theta) + m (\bar{\ell}_2 + \lambda_2 \theta), n \lambda_1 + m \lambda_2 + \theta)$$



$$\begin{aligned}
 &= n\lambda_1 + m\lambda_2 + \theta + \lambda_1 \frac{(\bar{z} + n(\bar{\ell}_1 + \lambda_1\theta) + m(\bar{\ell}_2 + \lambda_2\theta))\ell_2 - (z + n\ell_1 + m\ell_2)\bar{\ell}_2}{2i \text{ vol}} \\
 &\quad + \lambda_2 \frac{(z + n\ell_1 + m\ell_2)\bar{\ell}_1 - (\bar{z} + n(\bar{\ell}_1 + \lambda_1\theta) + m(\bar{\ell}_2 + \lambda_2\theta))\ell_1}{2i \text{ vol}} \\
 &= \theta + \lambda_1 \frac{\bar{z}\ell_2 - z\bar{\ell}_2}{2i \text{ vol}} + \lambda_2 \frac{z\bar{\ell}_1 - \bar{z}\ell_1}{2i \text{ vol}},
 \end{aligned}$$

where we used (62). Hence  $\tilde{p}_\Lambda$  determines a map  $p_\Lambda : T_\Lambda^{2|1} \rightarrow S \times \mathbb{R}^{0|1}$ , which is the map in (64). From this we see that the dashed arrow in (37) is unique and determined by

$$(66) \quad \theta \mapsto \bar{u} \left( \theta + \eta + \frac{(\lambda_1\ell_2 - \lambda_2\ell_1)(\bar{w} + \theta\eta) - (\lambda_1\bar{\ell}_2 - \lambda_2\bar{\ell}_1)w}{2i \text{ vol}} \right).$$

As in Remark 2.11, the left action of  $\mathbb{E}^{2|1} \rtimes \text{Spin}(2)$  on  $(x + \theta\psi) \in \text{Map}(\mathbb{R}^{0|1}, M)(S)$  is given by

$$\begin{aligned}
 (x + \theta\psi) &\mapsto x + \bar{u}^{-1} \left( \theta - \eta + \frac{(\lambda_1\ell_2 - \lambda_2\ell_1)(-\bar{w} - \theta\eta) + (\lambda_1\bar{\ell}_2 - \lambda_2\bar{\ell}_1)w}{2i \text{ vol}} \right) \psi \\
 &= x - \bar{u}^{-1} \left( \eta + \frac{(\lambda_1\ell_2 - \lambda_2\ell_1)\bar{w} - (\lambda_1\bar{\ell}_2 - \lambda_2\bar{\ell}_1)w}{2i \text{ vol}} \right) \psi \\
 &\quad + \bar{u}^{-1} \theta \left( 1 - \eta \frac{\lambda_1\ell_2 - \lambda_2\ell_1}{2i \text{ vol}} \right) \psi,
 \end{aligned}$$

which gives the claimed formula for  $(x', \psi')$ . Finally, a short computation shows that  $p_\Lambda = p_{\Lambda'} \circ \gamma$ , where  $\gamma : T_{\Lambda'}^{2|1} \rightarrow T_\Lambda^{2|1}$  is the isometry associated to  $\gamma \in \text{SL}_2(\mathbb{Z})(S)$  from Lemma 3.11. Hence, the  $\text{SL}_2(\mathbb{Z})$ -action on  $s\text{Lat} \times \text{Map}(\mathbb{R}^{0|1}, M)$  is indeed through the action on  $s\text{Lat}$ . □

From the Lie algebra description (50), a left  $\mathbb{E}^{2|1}$ -action determines an even and an odd vector field gotten by considering the infinitesimal action by the elements  $Q = \partial_\theta + \theta\partial_{\bar{z}}$  and  $\partial_z$  of the Lie algebra of  $\mathbb{E}^{2|1}$ . We note the isomorphisms

$$\begin{aligned}
 (67) \quad C^\infty(\mathcal{L}_0^{1|1}(M)) &\simeq C^\infty(s\text{Lat} \times \text{Map}(\mathbb{R}^{0|1}, M)) \\
 &\simeq C^\infty(\text{Lat} \times \text{Map}(\mathbb{R}^{0|1}, M))[\lambda_1, \lambda_2]/(\lambda_1\lambda_2) \\
 &\simeq (C^\infty(\text{Lat}) \otimes \Omega^\bullet(M))[\lambda_1, \lambda_2]/(\lambda_1\lambda_2),
 \end{aligned}$$

where in (67) we used that the projective tensor product of Fréchet spaces satisfies

$$C^\infty(S \times T) \simeq C^\infty(S) \otimes C^\infty(T)$$

for supermanifolds  $S$  and  $T$ ; see eg [20, Example 49].

**Lemma 3.18** *The derivative at 0 of the left  $\mathbb{E}^{2|1}$ -action on  $\mathcal{L}_0^{2|1}(M)$  from (63) is determined by the derivations on  $C^\infty(\mathcal{L}_0^{2|1}(M))$ ,*

$$(68) \quad \begin{aligned} \widehat{\partial}_w &= \frac{\lambda_1 \bar{\ell}_2 - \lambda_2 \bar{\ell}_1}{2i \text{ vol}} \otimes d, \\ \widehat{Q} &= 2\lambda_1 \partial_{\bar{\ell}_1} \otimes \text{id} + 2\lambda_2 \partial_{\bar{\ell}_2} \otimes \text{id} - \text{id} \otimes d - \frac{\lambda_2 \ell_1 - \lambda_1 \ell_2}{2i \text{ vol}} \otimes \text{deg}, \end{aligned}$$

where  $d$  is the de Rham differential and  $\text{deg}$  is the degree endomorphism on forms.

**Proof** The proof follows the same reasoning as the proof of Lemma 2.14, using that right-invariant vector fields generate left actions and that the  $\mathbb{E}^{0|1} \rtimes \mathbb{C}^\times$ -action on  $\text{Map}(\mathbb{R}^{0|1}, M)$  is generated by minus the de Rham operator and the degree derivation. In this case we apply the derivation  $Q = \partial_\eta + \eta \partial_{\bar{w}}$  and  $\partial_w$  to (63) (with  $(u, \bar{u}) = (1, 1)$ ) and evaluate at  $(w, \bar{w}, \eta) = (0, 0, 0)$  to obtain (68).  $\square$

### 3.4 The proof of Proposition 1.5

Functions on  $\mathcal{L}_0^{2|1}(M)$  can be described as

$$(69) \quad \begin{aligned} C^\infty(\mathcal{L}_0^{2|1}(M)) &= C^\infty(s\text{Lat} \times \text{Map}(\mathbb{R}^{0|1}, M)) \\ &\simeq \Omega^\bullet(M; C^\infty(s\text{Lat})) \simeq \Omega^\bullet(M; C^\infty(\text{Lat})[\lambda_1, \lambda_2]/(\lambda_1 \lambda_2)) \\ &\simeq \Omega^\bullet(M; C^\infty(\text{Lat})) \oplus \lambda_1 \cdot \Omega^\bullet(M; C^\infty(\text{Lat})) \oplus \lambda_2 \cdot \Omega^\bullet(M; C^\infty(\text{Lat})), \end{aligned}$$

using Lemma 3.12 in the second-to-last line, and where the isomorphism in the final line is additive. We start by proving a version of Proposition 1.5 for invariants by

$$\mathbb{E}^{2|1} \rtimes \mathbb{Z}/2 < \mathbb{E}^{2|1} \rtimes \text{Spin}(2) \times \text{SL}_2(\mathbb{Z}) = \text{Euc}_{2|1}.$$

Analogously to the notation in Section 2.4, let  $\text{vol}^{\text{deg}} \omega = \text{vol}^k \omega$  for  $\omega \in \Omega^k(M)$ .

**Lemma 3.19** *Any element  $\omega \in C^\infty(\mathcal{L}_0^{2|1}(M))^{\mathbb{Z}/2}$  can be written as*

$$(70) \quad \omega = \text{vol}^{\text{deg}/2}(\omega_0 + 2\lambda_1 \text{vol}^{1/2} \omega_1 + 2\lambda_2 \text{vol}^{1/2} \omega_2),$$

where  $\omega_0 \in \Omega^{\text{ev}}(M; C^\infty(\text{Lat}))$  and  $\omega_1, \omega_2 \in \Omega^{\text{odd}}(M; C^\infty(\text{Lat}))$ . A  $\mathbb{Z}/2$ -invariant function  $\omega$  expressed as (70) is  $\mathbb{E}^{2|1}$ -invariant if and only if

$$(71) \quad d\omega_0 = 0, \quad \partial_{\bar{\ell}_1} \omega_0 = d\omega_1 \quad \text{and} \quad \partial_{\bar{\ell}_2} \omega_0 = d\omega_2,$$

where  $d$  is the de Rham differential on  $M$ .

**Proof** The element  $-1 \in U(1) \simeq \text{Spin}(2)$  acts through the parity involution, which on  $C^\infty(s\text{Lat})$  is determined by  $\lambda_i \mapsto -\lambda_i$ . Using (69) and the fact that  $\text{vol}$  is an invertible function on  $\text{Lat}$ , we see that any  $\mathbb{Z}/2$ -invariant function can be written in the form (70). Next we compute for  $\omega_0 \in \Omega^k(M; C^\infty(\text{Lat}))$ ,

$$\begin{aligned} 2(\lambda_1 \partial_{\bar{\ell}_1} + \lambda_2 \partial_{\bar{\ell}_2})(\text{vol}^{k/2} \omega_0) &= 2(\lambda_1 \partial_{\bar{\ell}_1} + \lambda_2 \partial_{\bar{\ell}_2}) \left( \left( \frac{\ell_1 \bar{\ell}_2 - \bar{\ell}_1 \ell_2}{2i} \right)^{k/2} \omega_0 \right) \\ &= \frac{\lambda_2 \ell_1 - \lambda_1 \ell_2}{2i \text{vol}} \text{deg}(\text{vol}^{k/2} \omega_0) + 2 \text{vol}^{k/2} (\lambda_1 \partial_{\bar{\ell}_1} + \lambda_2 \partial_{\bar{\ell}_2}) \omega_0. \end{aligned}$$

So, by Lemma 3.18,

$$\widehat{Q}(\text{vol}^{\text{deg}/2} \omega_0) = \text{vol}^{\text{deg}/2} (2(\lambda_1 \partial_{\bar{\ell}_1} + \lambda_2 \partial_{\bar{\ell}_2}) \omega_0 - \text{vol}^{-1/2} d\omega_0).$$

Using that  $\lambda_1^2 = \lambda_2^2 = \lambda_1 \lambda_2 = 0$ , we compute

$$\begin{aligned} \widehat{Q}(\text{vol}^{\text{deg}/2} \omega_0 + 2\lambda_1 \text{vol}^{(\text{deg}+1)/2} \omega_1 + 2\lambda_2 \text{vol}^{(\text{deg}+1)/2} \omega_2) &= \text{vol}^{\text{deg}/2} (2(\lambda_1 \partial_{\bar{\ell}_1} + \lambda_2 \partial_{\bar{\ell}_2}) \omega_0 - \text{vol}^{-1/2} d\omega_0 - 2\lambda_1 d\omega_1 - 2\lambda_2 d\omega_2). \end{aligned}$$

Matching coefficients of  $\lambda_1$  and  $\lambda_2$ , the condition  $\widehat{Q}\omega = 0$  is therefore equivalent to (71). Finally, invariance under the operator  $\widehat{\partial}_w$  from Lemma 3.18 follows from being  $\widehat{Q}$ -closed, specifically from  $d\omega_0 = 0$ . Since  $\mathbb{E}^{2|1}$  is connected with Lie algebra generated by  $\widehat{Q}$  and  $\widehat{\partial}_w$ , we find that (71) completely specifies the subalgebra  $C^\infty(\mathcal{L}_0^{2|1}(M))^{\mathbb{E}^{2|1} \rtimes \mathbb{Z}/2} \subset C^\infty(\mathcal{L}_0^{2|1}(M))^{\mathbb{Z}/2}$ . □

Next we compute the  $\text{Spin}(2)$ -invariant functions. Consider the surjective map

$$(72) \quad \varphi: \text{Lat} \rightarrow \mathbb{H} \times \mathbb{R}_{>0}, \quad (\ell_1, \bar{\ell}_1, \ell_2, \bar{\ell}_2) \mapsto (\ell_1/\ell_2, \bar{\ell}_1/\bar{\ell}_2, \text{vol}) \in (\mathbb{H} \times \mathbb{R}_{>0})(S),$$

and use the pullback on functions to get an injection

$$(73) \quad C^\infty(\mathbb{H} \times \mathbb{R}_{>0})[\beta, \beta^{-1}] \hookrightarrow C^\infty(\text{Lat}), \quad f\beta^k \mapsto (\varphi^* f)\ell_2^{-k}.$$

We observe that the image of this map is precisely  $\bigoplus_{k \in \mathbb{Z}} C_k^\infty(\text{Lat})$  for

$$C_k^\infty(\text{Lat}) := \{f \in C^\infty(\text{Lat}) \mid f(u^2 \ell_1, \bar{u}^2 \ell_1, u^2 \ell_2, \bar{u}^2 \ell_2) = u^{-k} f(\ell_1, \bar{\ell}_1, \ell_2, \bar{\ell}_2)\},$$

the vector space of smooth functions of weight  $k/2$ , where  $(u, \bar{u})$  are the standard coordinates on  $U(1) \simeq \text{Spin}(2)$ . Indeed,  $C^\infty(\mathbb{H} \times \mathbb{R}_{>0})$  includes as  $C_0^\infty(\text{Lat}) \simeq C^\infty(\text{Lat})^{\text{Spin}(2)}$ ,  $C_k^\infty(\text{Lat}) = \{0\}$  for  $k$  odd, and there are isomorphisms of vector spaces  $C_{2k}^\infty(\text{Lat}) \xrightarrow{\sim} C_0^\infty(\text{Lat}) \simeq C^\infty(\text{Lat})^{\text{Spin}(2)}$  gotten by multiplication with  $\ell_2^k$ .

**Lemma 3.20** *An element  $\omega \in C^\infty(\mathcal{L}_0^{2|1}(M))^{\text{Spin}(2)} \subset C^\infty(\mathcal{L}_0^{2|1}(M))^{\mathbb{Z}/2}$  expressed in the form (70) has  $\omega_0, \omega_1, \omega_2$  in the image of the inclusion*

$$(74) \quad \Omega^\bullet(M; C^\infty(\mathbb{H} \times \mathbb{R}_{>0})[\beta, \beta^{-1}]) \hookrightarrow \Omega^\bullet(M; C^\infty(\text{Lat})), \quad \text{with } |\beta| = -2,$$

*determined by the map (73) on coefficients, where  $\omega_0$  is in the image of an element of total degree zero and  $\omega_1, \omega_2$  are in the image of elements of total degree  $-1$ .*

**Proof** From the description of the Spin(2)–action in (63), if

$$\omega \in C^\infty(\mathcal{L}_0^{2|1}(M))^{\text{Spin}(2)} \subset C^\infty(\mathcal{L}_0^{2|1}(M))^{\mathbb{Z}/2},$$

we obtain the refinement of the conditions from (70),

$$\begin{aligned} \omega_0 &\in \bigoplus_{k \in \mathbb{Z}} \Omega^{2k}(M; C_{2k}^\infty(\text{Lat})) \simeq \bigoplus_{k \in \mathbb{Z}} \Omega^{2k}(M; \ell_2^{-k} C_0^\infty(\text{Lat})) \\ &\subset \Omega^{\text{ev}}(M; C_0^\infty(\text{Lat})[\ell_2^{-1}]), \\ \omega_1, \omega_2 &\in \bigoplus_{k \in \mathbb{Z}} \Omega^{2k-1}(M; C_{2k}^\infty(\text{Lat})) \simeq \bigoplus_{k \in \mathbb{Z}} \Omega^{2k-1}(M; \ell_2^{-k} C_0^\infty(\text{Lat})) \\ &\subset \Omega^{\text{odd}}(M; C_0^\infty(\text{Lat})[\ell_2^{-1}]). \end{aligned}$$

This gives the description

$$(75) \quad \omega = (\text{vol}/\ell_2)^{\text{deg}/2} \omega'_0 + 2\lambda_1 (\text{vol}/\ell_2)^{(\text{deg}+1)/2} \omega'_1 + 2\lambda_2 (\text{vol}/\ell_2)^{(\text{deg}+1)/2} \omega'_2,$$

where  $\omega'_0, \omega'_1, \omega'_2 \in \Omega^\bullet(M; C^\infty(\text{Lat}))^{\text{Spin}(2)} \simeq \Omega^\bullet(M; C_0^\infty(\text{Lat}))$  are Spin(2)–invariant. After identifying  $\ell_2$  with  $\beta^{-1}$  as per (73), we obtain the claimed description.  $\square$

The following allows us to recast the invariance condition as a failure of  $Z = \omega_0$  to have holomorphic dependence on the conformal modulus and be independent of volume.

**Lemma 3.21** *An  $\mathbb{E}^{2|1} \times \text{Spin}(2)$ –invariant function on  $\mathcal{L}_0^{2|1}(M)$  is equivalent to a triple  $(Z, Z_{\bar{\tau}}, Z_v)$  where  $Z \in \Omega^\bullet(M; C^\infty(\mathbb{H} \times \mathbb{R}_{>0})[\beta, \beta^{-1}])$  has total degree zero and  $Z_v, Z_{\bar{\tau}} \in \Omega^\bullet(M; C^\infty(\mathbb{H} \times \mathbb{R}_{>0})[\beta, \beta^{-1}])$  have total degree  $-1$  and satisfy*

$$(76) \quad dZ = 0, \quad \partial_v Z = dZ_v \quad \text{and} \quad \partial_{\bar{\tau}} Z = dZ_{\bar{\tau}}$$

*for coordinates  $(\tau, \bar{\tau})$  on  $\mathbb{H}$  and  $v$  on  $\mathbb{R}_{>0}$ .*

**Proof** For the image of  $Z$  under (74), we differentiate

$$(77) \quad \begin{aligned} \partial_{\bar{\ell}_1} Z(\ell_1/\ell_2, \bar{\ell}_1/\bar{\ell}_2, \text{vol}) &= \frac{1}{\ell_2} \partial_{\bar{\tau}} Z - \frac{\ell_2}{2i} \partial_v Z, \\ \partial_{\bar{\ell}_2} Z(\ell_1/\ell_2, \bar{\ell}_1/\bar{\ell}_2, \text{vol}) &= -\frac{\bar{\ell}_1}{\bar{\ell}_2^2} \partial_{\bar{\tau}} Z + \frac{\ell_1}{2i} \partial_v Z. \end{aligned}$$

The result then follows from comparing with (71): writing  $\partial_{\bar{\ell}_1} Z$  and  $\partial_{\bar{\ell}_2} Z$  as d-exact forms is equivalent to writing  $\partial_{\bar{\tau}} Z$  and  $\partial_v Z$  as d-exact forms.  $\square$

**Definition 3.22** A function  $f \in C^\infty(\mathbb{H} \times \mathbb{R}_{>0})$  has weight  $(k, \bar{k}) \in \mathbb{Z} \times \mathbb{Z}$  if

$$f\left(\frac{a\tau + b}{c\tau + d}, v\right) = (c\tau + d)^k (c\bar{\tau} + d)^{\bar{k}} f(\tau, v).$$

Let  $\text{MF}_{k, \bar{k}} \subset C^\infty(\mathbb{H} \times \mathbb{R}_{>0})$  denote the  $\mathbb{C}$ -vector space of functions with weight  $(k, \bar{k})$ .

Consider the inclusion

$$(78) \quad \bigoplus_{k \in \mathbb{Z}} \text{MF}_{k, \bar{k}} \hookrightarrow C^\infty(\mathbb{H} \times \mathbb{R}_{>0})[\beta, \beta^{-1}], \quad f \mapsto \beta^k f \quad \text{for } f \in \text{MF}_{k, \bar{k}}.$$

**Lemma 3.23** In the notation of Lemma 3.21, a triple  $(Z, Z_v, Z_{\bar{\tau}})$  determines an  $\text{SL}_2(\mathbb{Z})$ -invariant function on  $\mathcal{L}_0^{2|1}(M)$  when

$$\begin{aligned} Z &\in \bigoplus_{k \in \mathbb{Z}} \Omega^{2k}(M; \text{MF}_{k,0}), \\ Z_v &\in \bigoplus_{k \in \mathbb{Z}} \Omega^{2k-1}(M; \text{MF}_{k,0}), \quad Z_{\bar{\tau}} \in \bigoplus_{k \in \mathbb{Z}} \Omega^{2k-1}(M; \text{MF}_{k,2}), \end{aligned}$$

using (78) to identify the above with elements of  $\Omega^\bullet(M; C^\infty(\mathbb{H} \times \mathbb{R}_{>0})[\beta, \beta^{-1}])$ .

**Proof** We observe that

$$\ell_2 \mapsto c\ell_1 + d\ell_2 = \ell_2(c\tau + d) \quad \text{for } \tau = \ell_1/\ell_2, \quad \begin{bmatrix} a & b \\ c & d \end{bmatrix} \in \text{SL}_2(\mathbb{Z}),$$

for the  $\text{SL}_2(\mathbb{Z})$ -action on  $\text{Lat}$ , so that (73) is an  $\text{SL}_2(\mathbb{Z})$ -invariant inclusion for the action on  $\mathbb{H}$  by fractional linear transformations and  $\beta \mapsto \beta/(c\tau + d)$ . The  $\text{SL}_2(\mathbb{Z})$ -invariant property for  $Z$  then follows directly. The properties for  $Z_v$  and  $Z_{\bar{\tau}}$  can either be deduced from the fact that (76) are  $\text{SL}_2(\mathbb{Z})$ -invariant equations, or by (a direct but tedious computation) using (77) to write  $Z_v$  and  $Z_{\bar{\tau}}$  in terms of  $\omega_0$  and  $\omega_1$ , and then applying the  $\text{SL}_2(\mathbb{Z})$ -actions on  $\omega_0, \omega_1, \omega_2$  computed in Lemma 3.17.  $\square$

**Proof of Proposition 1.5** The result follows from Lemmas 3.21 and 3.23.  $\square$

**Remark 3.24** As announced in [26, Theorem 1.15], a  $2|1$ -Euclidean field theory over  $M = \text{pt}$  has a partition function valued in *integral* modular forms. Theorem 1.1 when  $d = 2$  specializes to the holomorphy and modularity statements in this result when  $M = \text{pt}$ ; generalizing the integrality statement would require one to consider the values of field theories on super annuli with maps to  $M$ .

**Remark 3.25** The Lie groupoid  $\text{Lat} // \text{Spin}(2) \times \text{SL}_2(\mathbb{Z})$  gives a presentation of the moduli stack of Euclidean tori with periodic-periodic spin structure and choice of basepoint, where  $\text{SL}_2(\mathbb{Z}) \times \text{Spin}(2)$  acts via the restriction of the action from Lemma 3.17. The involution generated by  $-1 \in U(1) \simeq \text{Spin}(2)$  is the *spin flip automorphism*, which acts trivially on the underlying Euclidean torus and by the parity involution on the spinor bundle. Consider the subspace  $\mathbb{H} \times \mathbb{R}_{>0} \subset \text{Lat}$  of based lattices whose second generator  $\ell_2 \in \mathbb{R}_{>0} \subset \mathbb{C}^\times$  is positive and real. Since every based lattice can be rotated to one of this form (using the action of  $\text{Spin}(2)$  on  $\text{Lat}$ ) the full subgroupoid of  $\text{Lat} // \text{Spin}(2) \times \text{SL}_2(\mathbb{Z})$  with the objects  $\mathbb{H} \times \mathbb{R}_{>0} \subset \text{Lat}$  is equivalent to  $\text{Lat} // \text{Spin}(2) \times \text{SL}_2(\mathbb{Z})$ . Since  $\{\pm 1\} \subset \text{Spin}(2)$  acts trivially on the subspace  $\mathbb{H} \times \mathbb{R}_{>0} \subset \text{Lat}$ , the manifold of morphisms in this full subgroupoid is  $\mathbb{H} \times \mathbb{R}_{>0} \times \{\pm 1\} \times \text{SL}_2(\mathbb{Z})$ . Composition of morphisms gives the set  $\{\pm 1\} \times \text{SL}_2(\mathbb{Z})$  the structure of a group, which turns out to be the metaplectic double cover  $\text{MP}_2(\mathbb{Z})$  of  $\text{SL}_2(\mathbb{Z})$ . There is a functor between Lie groupoids  $u: \mathbb{H} \times \mathbb{R}_{>0} // \text{MP}_2(\mathbb{Z}) \rightarrow \mathbb{H} // \text{MP}_2(\mathbb{Z})$ , where the target is a standard presentation for the stack of complex-analytic elliptic curves endowed with a periodic-periodic spin structure. Geometrically, the functor  $u$  extracts the underlying complex-analytic elliptic curve with spin structure.

Finally, observe there is a functor  $\text{Lat} // \text{Spin}(2) \times \text{SL}_2(\mathbb{Z}) \rightarrow \mathcal{M}^{2|1} // \text{Euc}_{2|1}$ , so a family of Euclidean tori with spin structure and choice of basepoint determines a family of super tori. Our arguments involving super tori do not encounter the metaplectic double cover because at the outset (in Lemma 3.19) we restrict to functions invariant under the spin flip automorphism. Hence only the quotient  $\text{MP}_2(\mathbb{Z}) / \{\pm 1\} \simeq \text{SL}_2(\mathbb{Z})$  features in our arguments.

### 3.5 Weak modular forms and complexified TMF

**Definition 3.26** *Weak modular forms of weight  $k$*  are holomorphic functions  $f \in \mathcal{O}(\mathbb{H})$  satisfying

$$f\left(\frac{a\tau + b}{c\tau + d}\right) = (c\tau + d)^k f(\tau) \quad \text{for } \tau \in \mathbb{H}, \begin{bmatrix} a & b \\ c & d \end{bmatrix} \in \text{SL}_2(\mathbb{Z}).$$

Let  $\text{MF}_k$  denote the  $\mathbb{C}$ -vector space of weak modular forms of weight  $k$ . Define the graded ring of weak modular forms  $\text{MF}$  as the graded vector space

$$\text{MF} = \bigoplus_{k \in \mathbb{Z}} \text{MF}^k, \quad \text{where } \text{MF}^k := \begin{cases} \text{MF}_{k/2} & \text{if } k \text{ is even,} \\ 0 & \text{if } k \text{ is odd,} \end{cases}$$

with ring structure from multiplication of functions on  $\mathbb{H}$ .

Cohomology with coefficients in weak modular forms is the object that naturally appears when studying derived global sections of the elliptic cohomology sheaf in the complex-analytic context. Indeed, complex-analytic elliptic cohomology assigns to a smooth manifold  $M$  a sheaf  $\mathcal{E}ll(M)$  of differential graded algebras on the orbifold  $\mathbb{H}/\text{SL}_2(\mathbb{Z})$  with values

$$(79) \quad \mathcal{E}ll(M)(U) := (\mathcal{O}(U; \Omega^\bullet(M)[\beta, \beta^{-1}]), d) \quad \text{for } U \subset \mathbb{H}.$$

The  $\text{SL}_2(\mathbb{Z})$ -equivariance data for this sheaf comes from pulling back functions along fractional linear transformations and sending  $\beta \mapsto (c\tau + d)\beta$ . This connects with standard definitions of elliptic cohomology in homotopy theory (eg [21, Definition 1.2]) by identifying  $\mathbb{H}/\text{SL}_2(\mathbb{Z})$  with the moduli stack of complex-analytic elliptic curves, and values (79) with the de Rham complex for 2-periodic cohomology with coefficients in  $\mathcal{O}(U)$ . Using the Dolbeault resolution of holomorphic functions on  $\mathbb{H}$ , the complex  $(\Omega^\bullet(M; \Omega^{0,*}(\mathbb{H})[\beta, \beta^{-1}]^{\text{SL}_2(\mathbb{Z})}, d + \bar{\partial})$  computes the derived global sections (ie the hypercohomology) of the elliptic cohomology sheaf  $\mathcal{E}ll(M)$ . Since  $\mathbb{H}$  is Stein, the inclusion

$$\mathcal{O}(\mathbb{H}) \hookrightarrow (\Omega^{0,*}(\mathbb{H}), \bar{\partial})$$

is a quasi-isomorphism. Hence, derived global sections of the elliptic cohomology sheaf are cohomology with values in weak modular forms,

$$\text{H}(M; \mathcal{O}(\mathbb{H})[\beta, \beta^{-1}]^{\text{SL}_2(\mathbb{Z})}) \simeq \text{H}(M; \text{MF}).$$

We refer to [5, Section 3] for details.

A weak modular form is a *weakly holomorphic modular form* if it is meromorphic as  $\tau \rightarrow i\infty$ . For  $M$  compact, cohomology with values in weakly holomorphic modular forms is isomorphic to the complexification of topological modular forms,

$$(80) \quad \begin{aligned} \text{TMF}(M) \otimes \mathbb{C} &\simeq \text{H}(M; \text{TMF}(\text{pt}) \otimes \mathbb{C}) \subset \text{H}(M; \text{MF}), \\ \text{TMF}(\text{pt}) \otimes \mathbb{C} &\simeq \{\text{weakly holomorphic modular forms}\} \subset \text{MF}, \end{aligned}$$

and the inclusion on the right regards a weakly holomorphic modular form as a weak modular form. We expect the image of 2|1–Euclidean field theories along (4) to satisfy this meromorphicity property at  $i\infty$ , and hence have image in the subring  $\text{TMF}(M) \otimes \mathbb{C}$ . This follows from an “energy bounded below” condition discussed for  $M = \text{pt}$  in [26, Section 3]. However, proving that the image of field theories satisfies this condition requires that one analyze the values of field theories on super tori *and* super annuli.

### 3.6 Concordance classes of functions

The cocycle map (4) can be factored through a complex that computes the derived global sections of the elliptic cohomology sheaf, namely the complex

$$(\Omega^\bullet(M; \Omega^{0,*}(\mathbb{H})[\beta, \beta^{-1}])^{\text{SL}_2(\mathbb{Z})}, d + \bar{\partial})$$

described above.

**Definition 3.27** Using the notation from Proposition 1.5, for each  $\mu \in \mathbb{R}_{>0}$  define a map

$$\begin{aligned} \widehat{\text{cocycle}}_\mu : C^\infty(\mathcal{L}_0^{2|1}(M))^{\text{Euc}_{2|1}} &\rightarrow Z^0(\Omega^\bullet(M; \Omega^{0,*}(\mathbb{H})[\beta, \beta^{-1}]), d + \bar{\partial})^{\text{SL}_2(\mathbb{Z})}, \\ (Z, Z_{\bar{\tau}}, Z_v) &\mapsto Z(\mu) + d\bar{\tau}Z_{\bar{\tau}}(\mu), \end{aligned}$$

where the evaluation is at tori with volume  $v = \mu \in \mathbb{R}_{>0}$ .

**Lemma 3.28** *The composition*

$$C^\infty(\mathcal{L}_0^{2|1}(M))^{\text{Euc}_{2|1}} \xrightarrow{\widehat{\text{cocycle}}_\mu} Z^0(\Omega^\bullet(M; \Omega^{0,*}(\mathbb{H})[\beta, \beta^{-1}]), d + \bar{\partial})^{\text{SL}_2(\mathbb{Z})} \xrightarrow{\text{de Rham}} H(M; \text{MF})$$

*is independent of  $\mu$  and agrees with (4).*

**Proof** Let us verify that the map in Definition 3.27 is well-defined. By Proposition 1.5, the image is contained in the subspace of degree zero cocycles:

$$(d + \bar{\partial})(Z(\mu) + d\bar{\tau}Z_{\bar{\tau}}(\mu)) = d\bar{\tau}\partial_{\bar{\tau}}Z(\mu) - d\bar{\tau}dZ_{\bar{\tau}}(\mu) = 0.$$

The image is  $\text{SL}_2(\mathbb{Z})$ –invariant by Lemma 3.23. The remainder of the proof is completely analogous to that of Lemma 2.16. □



**Proof of Proposition 1.2 for  $d = 2$**  By Proposition 1.5,  $M \mapsto C^\infty(\mathcal{L}_0^{2|1}(M))^{\text{Eu}_{2|1}}$  is a sheaf on the site of smooth manifolds. The map in Definition 3.27 is a morphism of sheaves

$$\widehat{\text{cocycle}}_\mu : C^\infty(\mathcal{L}_0^{2|1}(-))^{\text{Eu}_{2|1}} \rightarrow Z^0(\Omega^\bullet(-; \Omega^{0,*}(\mathbb{H})[\beta, \beta^{-1}]), d + \bar{\partial})^{\text{SL}_2(\mathbb{Z})}.$$

When evaluated on a manifold  $M$ , concordance classes of sections of the target are cohomology classes. This completes the proof.  $\square$

### 3.7 The elliptic Euler class as a cocycle

For a real oriented vector bundle  $V \rightarrow M$ , consider the characteristic class

$$[\text{Eu}(V)] := \left[ \text{Pf}(-\beta F) \exp\left( \sum_{k \geq 1} \frac{\beta^k E_{2k}}{2k(2\pi i)^{2k}} \text{Tr}(F^{2k}) \right) \right]$$

in  $H^{\dim V}(M; C^\infty(\mathbb{H})[\beta, \beta^{-1}])^{\text{SL}_2(\mathbb{Z})}$ , where  $F = \nabla \circ \nabla \in \Omega^2(M; \text{End}(V))$  is the curvature for a choice of a metric-compatible connection  $\nabla$  on  $V$  and  $\text{Pf}(-\beta R)$  is the Pfaffian. The functions  $E_{2k} \in C^\infty(\mathbb{H})$  are the  $2k^{\text{th}}$  Eisenstein series, where we take  $E_2$  to be the modular, nonholomorphic version of the second Eisenstein series,

$$E_2(\tau, \bar{\tau}) = \lim_{\epsilon \rightarrow 0^+} \sum_{(n,m) \in \mathbb{Z}_*^2} \frac{1}{(n\tau + m)^2 |n\tau + m|^{2\epsilon}}, \quad E_2(\tau, \bar{\tau}) = E_2^{\text{hol}}(\tau) - \frac{2\pi i}{\tau - \bar{\tau}},$$

whose relationship with the holomorphic (but not modular) second Eisenstein series  $E_2^{\text{hol}}(\tau)$  is as indicated. For  $k > 1$ , the Eisenstein series  $E_{2k} \in \mathcal{O}(\mathbb{H})$  are holomorphic. Thus, if

$$[p_1(V)] = [\text{Tr}(F^2)/(2(2\pi i)^2)] \in H^4(M; \mathbb{R})$$

vanishes, then  $[\text{Eu}(V)] \in H^{\dim V}(M; \mathcal{O}(\mathbb{H})[\beta, \beta^{-1}])^{\text{SL}_2(\mathbb{Z})}$  is a holomorphic class.

When  $\dim V = 24k$ , we may ask for a preimage of  $\Delta^k [\text{Eu}(V)] \in H^0(M; \text{MF})$  under the cocycle map (4), where  $\Delta$  is the modular discriminant. We start with the differential form refinement of  $\text{Eu}(V)$ , evident from its definition above,

$$\text{Eu}(V) \in \Omega^\bullet(M; C^\infty(\mathbb{H})[\beta, \beta^{-1}]), \quad \partial_{\bar{\tau}} \text{Eu}(V) = \frac{\beta^2 \text{Tr}(F^2)}{4\pi i (\tau - \bar{\tau})^2} \text{Eu}(V),$$

and whose failure to be holomorphic is as indicated. Since  $\partial_v \text{Eu}(V) = 0$ , we may choose  $Z = \Delta^k \text{Eu}(V)$  and  $Z_v = 0$ . The remaining data to promote  $\Delta^k \text{Eu}(V)$  to a function on  $\mathcal{L}_0^{2|1}(M)$  is a choice of coboundary  $\partial_{\bar{\tau}}(\Delta^k \text{Eu}(V)) = dZ_{\bar{\tau}}$ , which in turn is determined by  $H \in \Omega^3(M)$  with  $dH = p_1(V)$ , ie a rational string structure.

This identifies the set of rational string structures on  $(V, \nabla)$  with choices of lift of  $\Delta^k[\text{Eu}(V)]$  to a function on  $\mathcal{L}_0^{2|1}(M)$ . We expect a similar story without the dimension restriction on  $V$  and the factors of  $\Delta$  though an enhancement of (4) that incorporates a degree  $n$  twist [26, Section 5].

## References

- [1] **O Alvarez, T P Killingback, M Mangano, P Windey**, *The Dirac–Ramond operator in string theory and loop space index theorems*, Nuclear Phys. B Proc. Suppl. 1A (1987) 189–215 MR Zbl
- [2] **B Arnold**, *The parallel transport of a superconnection*, in preparation
- [3] **T Barthel, D Berwick-Evans, N Stapleton**, *Power operations in the Stolz–Teichner program*, Geom. Topol. 26 (2022) 1773–1848 MR Zbl
- [4] **N Berline, E Getzler, M Vergne**, *Heat kernels and Dirac operators*, Grundle Math. Wissen. 298, Springer (1992) MR Zbl
- [5] **D Berwick-Evans**, *Supersymmetric localization, modularity and the Witten genus*, preprint (2019) arXiv 1911.11015 To appear in J. Differential Geometry
- [6] **D Berwick-Evans**, *Supersymmetric field theories and the elliptic index theorem with complex coefficients*, Geom. Topol. 25 (2021) 2287–2384 MR Zbl
- [7] **D Berwick-Evans**, *Equivariant elliptic cohomology, gauged sigma models, and discrete torsion*, Trans. Amer. Math. Soc. 375 (2022) 369–427 MR Zbl
- [8] **D Berwick-Evans, A Tripathy**, *A model for complex analytic equivariant elliptic cohomology from quantum field theory*, preprint (2018) arXiv 1805.04146
- [9] **A Dabholkar, P Putrov, E Witten**, *Duality and mock modularity*, SciPost Phys. 9 (2020) art. id. 072 MR
- [10] **P Deligne, P Etingof, D S Freed, L C Jeffrey, D Kazhdan, J W Morgan, D R Morrison, E Witten** (editors), *Quantum fields and strings: a course for mathematicians, I*, Amer. Math. Soc., Providence, RI (1999) MR Zbl
- [11] **P Deligne, D S Freed**, *Sign manifesto*, from “Quantum fields and strings: a course for mathematicians, I” (P Deligne, P Etingof, D S Freed, L C Jeffrey, D Kazhdan, J W Morgan, D R Morrison, E Witten, editors), Amer. Math. Soc., Providence, RI (1999) 357–363 MR Zbl
- [12] **P Deligne, J W Morgan**, *Notes on supersymmetry (following Joseph Bernstein)*, from “Quantum fields and strings: a course for mathematicians, I” (P Deligne, P Etingof, D S Freed, L C Jeffrey, D Kazhdan, J W Morgan, D R Morrison, E Witten, editors), Amer. Math. Soc., Providence, RI (1999) 41–97 MR Zbl

- [13] **R Donagi, E Witten**, *Supermoduli space is not projected*, from “String-Math 2012” (R Donagi, S Katz, A Klemm, D R Morrison, editors), Proc. Sympos. Pure Math. 90, Amer. Math. Soc., Providence, RI (2015) 19–71 MR Zbl
- [14] **F Dumitrescu**, *Superconnections and parallel transport*, Pacific J. Math. 236 (2008) 307–332 MR Zbl
- [15] **D S Freed**, *Five lectures on supersymmetry*, Amer. Math. Soc., Providence, RI (1999) MR Zbl
- [16] **D Gaiotto, T Johnson-Freyd**, *Mock modularity and a secondary elliptic genus*, preprint (2019) arXiv 1904.05788
- [17] **D Gaiotto, T Johnson-Freyd, E Witten**, *A note on some minimally supersymmetric models in two dimensions*, from “Integrability, quantization, and geometry, II: Quantum theories and algebraic geometry” (S Novikov, I Krichever, O Ogievetsky, S Shlosman, editors), Proc. Sympos. Pure Math. 103, Amer. Math. Soc., Providence, RI (2021) 203–221 MR Zbl
- [18] **F Han**, *Supersymmetric QFT, super loop spaces and Bismut–Chern character*, preprint (2008) arXiv 0711.3862v3
- [19] **H Hohnhold, M Kreck, S Stolz, P Teichner**, *Differential forms and 0–dimensional supersymmetric field theories*, Quantum Topol. 2 (2011) 1–41 MR Zbl
- [20] **H Hohnhold, S Stolz, P Teichner**, *From minimal geodesics to supersymmetric field theories*, from “A celebration of the mathematical legacy of Raoul Bott” (P R Kotiuga, editor), CRM Proc. Lecture Notes 50, Amer. Math. Soc., Providence, RI (2010) 207–274 MR Zbl
- [21] **J Lurie**, *A survey of elliptic cohomology*, from “Algebraic topology” (N A Baas, E M Friedlander, B Jahren, P A Østvær, editors), Abel Symp. 4, Springer (2009) 219–277 MR Zbl
- [22] **D Quillen**, *Superconnections and the Chern character*, Topology 24 (1985) 89–95 MR Zbl
- [23] **G Segal**, *Elliptic cohomology (after Landweber–Stong, Ochanine, Witten, and others)*, from “Séminaire Bourbaki 1987/88”, Astérisque 161–162, Soc. Math. France, Paris (1988) Exposé 695, 187–201 MR Zbl
- [24] **G Segal**, *The definition of conformal field theory*, from “Topology, geometry and quantum field theory” (U Tillmann, editor), London Math. Soc. Lecture Note Ser. 308, Cambridge Univ. Press (2004) 421–577 MR Zbl
- [25] **S Stolz, P Teichner**, *What is an elliptic object?*, from “Topology, geometry and quantum field theory” (U Tillman, editor), London Math. Soc. Lecture Note Ser. 308, Cambridge Univ. Press (2004) 247–343 MR Zbl

- [26] **S Stolz, P Teichner**, *Supersymmetric field theories and generalized cohomology*, from “Mathematical foundations of quantum field theory and perturbative string theory” (H Sati, U Schreiber, editors), Proc. Sympos. Pure Math. 83, Amer. Math. Soc., Providence, RI (2011) 279–340 MR Zbl
- [27] **E Witten**, *Supersymmetry and Morse theory*, J. Differential Geometry 17 (1982) 661–692 MR Zbl
- [28] **E Witten**, *Elliptic genera and quantum field theory*, Comm. Math. Phys. 109 (1987) 525–536 MR Zbl
- [29] **E Witten**, *The index of the Dirac operator in loop space*, from “Elliptic curves and modular forms in algebraic topology” (P S Landweber, editor), Lecture Notes in Math. 1326, Springer (1988) 161–181 MR Zbl
- [30] **E Witten**, *Notes on super Riemann surfaces and their moduli*, Pure Appl. Math. Q. 15 (2019) 57–211 MR Zbl

*Department of Mathematics, University of Illinois at Urbana-Champaign  
Urbana, IL, United States*

danbe@illinois.edu

Proposed: Mark Behrens

Seconded: Haynes R Miller, Nathalie Wahl

Received: 13 November 2020

Revised: 26 August 2021

# Isotopy of the Dehn twist on $K3 \# K3$ after a single stabilization

JIANFENG LIN

Kronheimer and Mrowka recently proved that the Dehn twist along a 3–sphere in the neck of  $K3 \# K3$  is not smoothly isotopic to the identity. This provides a new example of self-diffeomorphisms on 4–manifolds that are isotopic to the identity in the topological category but not smoothly so. (The first such examples were given by Ruberman.) We use the  $\text{Pin}(2)$ –equivariant Bauer–Furuta invariant to show that this Dehn twist is not smoothly isotopic to the identity even after a single stabilization (connected summing with the identity map on  $S^2 \times S^2$ ). This gives the first example of exotic phenomena on simply connected smooth 4–manifolds that do not disappear after a single stabilization.

57R50, 57R52, 57R57; 55P91

## 1 Introduction

Understanding smooth structures on 4–manifolds remains one of the most difficult topics in low-dimensional topology. In this dimension, many results that hold in the topological category do not hold in the smooth category. Such phenomena are called “exotic phenomena.” To motivate our discussion, we list three major instances of exotic phenomena:

- By the groundbreaking work of Donaldson [16; 18] and Freedman [20] (and many subsequent works), there exist many pairs of simply connected closed smooth 4–manifolds that are homeomorphic but not diffeomorphic.
- Ruberman [33] gave the first example of self-diffeomorphisms on 4–manifolds that are isotopic to the identity in the topological category, but not smoothly so. Further examples are given by Auckly, Kim, Melvin and Ruberman [5], Akbulut [3], Baraglia and Konno [8] and Kronheimer and Mrowka [26].

- By the combined work of Wall [36], Perron [31], Quinn [32] and Donaldson [16], there exist pairs of embedded 2–spheres in 4–manifolds with simply connected complement that are topologically isotopic to each other, but not smoothly so; see [3; 5] for explicit families of such examples.

Exotic phenomena appear in each of these three problems, which we call the “diffeomorphism existence problem”, the “diffeomorphism isotopy problem” and the “surface isotopy problem”. A fundamental principle, discovered by Wall [36; 37] in the 1960s, states that these exotic phenomena will eventually disappear after sufficient many stabilizations on the 4–manifolds. (Here stabilization means taking the connected sum with  $S^2 \times S^2$ .) More precisely:

- Wall [37] proved that any pair of homotopy equivalent simply connected smooth 4–manifolds are stably diffeomorphic. Namely, they become diffeomorphic after sufficiently many stabilizations.

- Gompf [22] and Kreck [25] further proved that any pair of homeomorphic orientable smooth 4–manifolds (not necessarily simply connected) are stable diffeomorphic. They also proved that nonorientable pairs can be made stably diffeomorphic by first doing a twisted stabilization (ie connected summing a twisted bundle  $S^2 \tilde{\times} S^2$ ). In fact, for any  $G$  with  $H^1(G; \mathbb{Z}/2) \neq 0$ , Kreck [24] constructed examples of homeomorphic nonorientable smooth 4–manifold pairs with fundamental group  $G$  which are not stably diffeomorphic. (Different constructions of such examples were given by Cappell and Shaneson [13] for  $G = \mathbb{Z}/2$  and Akbulut [2] for  $G = \mathbb{Z}$ .) This implies that a twisted stabilization is indeed necessary in the nonorientable case.

- By combining the results of Kreck [23] and Quinn [32], we know that homotopic diffeomorphisms of any simply connected smooth 4–manifold are smoothly isotopic after sufficient many stabilizations. Here stabilization means first isotoping the diffeomorphisms so that they all pointwise fix a small ball  $B$ , and then taking the connected sum with the identity map on  $S^2 \times S^2$  along  $B$ .

- The work of Wall [36], Perron [31] and Quinn [32] shows that any two homologous closed surfaces of the same genus embedded in a 4–manifold with simply connected complement become smoothly isotopic after sufficiently many *external stabilizations*. Here external means that the connected sums with  $S^2 \times S^2$  are taken away from the surfaces.

These results motivate the following natural question:

**Question 1.1** *How many stabilizations are necessary in each of these three problems?*

There has been speculation that one stabilization is actually enough in all three problems. This is based on several known results:

- It is shown by Baykur and Sunukjian [12] that exotic pairs of nonspin 4–manifolds produced by “standard methods” (logarithmic transforms, knot surgeries, and rational blow-downs) all become diffeomorphic after a single stabilization.
- In the large families of examples (of embedded surfaces and self-diffeomorphisms) established in Akbulut [3] and Auckly, Kim, Melvin and Ruberman [5], exactly one stabilization is needed.
- Auckly, Kim, Ruberman, Melvin and Schwartz [6] proved that any two homologous surfaces  $F_1$  and  $F_2$  of the same genus embedded in a smooth 4–manifold  $X$  with simply connected complements are smoothly isotopic after a single stabilization if they are not characteristic (ie  $[F_i]$  is not dual to the Stiefel–Whitney class  $w_2(X)$ ). This shows that in the noncharacteristic case, one stabilization is indeed enough in the surface isotopy problem. (When the surfaces are characteristic, they proved a similar result involving a single twisted stabilization.)

We prove the following theorem.

**Theorem 1.2** (main theorem) *Let  $\delta$  be the Dehn twist along a separating 3–sphere in the neck of the connected sum  $K3 \# K3$ . Then  $\delta$  is **not** smoothly isotopic to the identity map even after a single stabilization.*

To the author’s knowledge, Theorem 1.2 provides the first example that exotic phenomena on simply connected smooth 4–manifolds do not disappear after a single stabilization with respect to  $S^2 \times S^2$ . In particular, it implies that one stabilization is in general *not* enough in the diffeomorphism isotopy problem.

Note that Kronheimer and Mrowka [26] proved that  $\delta$  itself is not smoothly isotopic to the identity, using the nonequivariant Bauer–Furuta invariant for spin families. Our result is based on the Kronheimer–Mrowka theorem and makes use of the  $\text{Pin}(2)$ –equivariant version of the Bauer–Furuta invariant. This invariant was defined in Bauer and Furuta [11] (for a single manifold) and in Szymik [35] and Xu [38] (for families). It has been extensively studied in many papers, including Baraglia [7] and Baraglia and Konno [9], and it is the central tool in Furuta’s proof of the  $\frac{10}{8}$ –theorem [21]. The idea of using gauge-theoretic invariants for families to study the isotopy problem first

appears in Ruberman [33]. The idea of using the  $\text{Pin}(2)$ -equivariant Bauer–Furuta invariant to further study Dehn twists on 4-manifolds was suggested by Kronheimer and Mrowka in [26].

We outline the proof of Theorem 1.2: By taking the mapping torus of  $\delta$ , we form a smooth bundle  $N$  with fiber  $K3 \# K3$  and base  $S^1$ . Then it suffices to show that the bundle  $\tilde{N}$ , formed by fiberwise connected sum between  $N$  and  $(S^2 \times S^2) \times S^1$ , is not a product bundle. This is proved by showing that the  $\text{Pin}(2)$ -equivariant Bauer–Furuta invariant  $\text{BF}^{\text{Pin}(2)}(\tilde{N})$  is nonvanishing for both spin structures. Note that  $\text{BF}^{\text{Pin}(2)}(\tilde{N})$  equals the product of  $\text{BF}^{\text{Pin}(2)}(N)$  with the Euler class  $e_{\tilde{\mathbb{R}}}$  (a stable homotopy class represented by the inclusion from  $S^0 = \{0, \infty\}$  to the 1-dimensional representation sphere  $S^{\tilde{\mathbb{R}}}$ ). We prove this by contradiction, assuming

$$(1) \quad \text{BF}^{\text{Pin}(2)}(N) \cdot e_{\tilde{\mathbb{R}}} = 0.$$

This gives information on  $\text{BF}^{\text{Pin}(2)}(N)$  and its  $S^1$ -reduction

$$\text{BF}^{S^1}(N) \in \{S^{\mathbb{R}+2\mathbb{H}}, S^{6\tilde{\mathbb{R}}}\}^{S^1}.$$

We can explicitly compute the homotopy group  $\{S^{\mathbb{R}+2\mathbb{H}}, S^{6\tilde{\mathbb{R}}}\}^{S^1}$  as  $\mathbb{Z} \oplus \mathbb{Z}/2$ . Based on this computation, information from (1) and the fact that  $\text{BF}^{S^1}(N)$  gives a vanishing family Seiberg–Witten invariant, we can prove that  $\text{BF}^{S^1}(N) = 0$ . This further implies that the nonequivariant Bauer–Furuta invariant  $\text{BF}^{\{e\}}(N)$  vanishes, which contradicts Kronheimer and Mrowka’s result that  $\text{BF}^{\{e\}}(N)$  equals the nonzero element  $\eta^3 \in \pi_3$ . Note that  $e_{\tilde{\mathbb{R}}}$  becomes trivial when reducing to the subgroup  $S^1 \subset \text{Pin}(2)$ . As a consequence, the  $S^1$ -equivariant Bauer–Furuta invariant vanishes after a single stabilization (just like the classical Seiberg–Witten invariants and Donaldson’s polynomial invariants). This explains why the  $\text{Pin}(2)$ -equivariance is essential in our proof.

We end this introductory section by remarking that it is still open whether one stabilization is enough to make any pairs of simply connected homeomorphic 4-manifolds diffeomorphic. (See Akbulut, Mrowka and Ruan [4], Donaldson [17] and Fintushel and Stern [19] for a possible approach using the 2-torsion instanton invariants.) It’s also unknown whether two homotopic characteristic surfaces with simply connected complements become smoothly isotopic after a single stabilization. The proof of Theorem 1.2 suggests that the Bauer–Furuta invariant could be useful in attacking these problems. As a first step, one needs to establish new examples of spin 4-manifolds with sufficiently interesting higher-dimensional  $\text{Pin}(2)$ -equivariant Bauer–Furuta invariants. Note that in a recent paper by the author and Mukherjee [29], we use Theorem 1.2 to



establish the first pair of orientable exotic surfaces (in a punctured  $K3$  surface) which are not smoothly isotopic even after one stabilization.

The paper is organized as follows: In Section 2, we give a brief review of some basic  $\text{Pin}(2)$ -equivariant stable homotopy theory and recall the definition of the equivariant Bauer–Furuta invariant. We also use this section to set up notation and to adapt some standard results to our setting. The actual proof of Theorem 1.2 is given in Section 3. Experts may directly skip to Section 3 and occasionally refer back to Section 2 for notation and results.

**Acknowledgements** The author is partially supported by NSF grant DMS-1949209. The author would like to thank Tye Lidman and Danny Ruberman for very enlightening conversations, Mark Powell for pointing out Kreck’s work [24], and Selman Akbulut for explaining his work in [2; 3].

## 2 Background

### 2.1 $\text{Pin}(2)$ -equivariant homotopy theory

In this section, we collect some standard results (mostly from [1; 28; 30; 34]) on  $G$ -equivariant stable homotopy theory in the case

$$G = \text{Pin}(2) = \{e^{i\theta}\} \cup \{j \cdot e^{i\theta}\} \subset \mathbb{H}.$$

Instead of stating the most general form of these results, we will only focus on the special cases that are actually needed in our argument. We refer to [1; 34] for an introduction to equivariant stable homotopy theory (in the case of finite groups) and to [28; 30] for a more general treatment.

Since all objects we study here are finite  $G$ -CW complexes, for simplicity, we will work with the  $G$ -equivariant Spanier–Whitehead category [1] (instead of the homotopy category of  $G$ -spectra). Of course, there are a lot of drawbacks (eg one cannot always take limits/colimits), but it is enough for our purpose.

**2.1.1 Basic facts and definitions** Let  $U$  be a countably infinite-dimensional  $G$ -representation space equipped with a  $G$ -invariant inner product, which we call a “universe”. We assume that  $U$  contains the concrete representation

$$\left(\bigoplus_{\infty} \mathbb{R}\right) \oplus \left(\bigoplus_{\infty} \tilde{\mathbb{R}}\right) \oplus \left(\bigoplus_{\infty} \mathbb{H}\right).$$

Here  $\mathbb{R}$  is the trivial representation,  $\tilde{\mathbb{R}}$  is the 1-dimensional representation on which  $S^1$  acts trivially and  $j$  acts as  $-1$ , and  $\mathbb{H}$  is acted upon by  $G$  via left multiplication in the quaternions.

To apply the results in [30] directly without checking additional conditions, we further assume that  $U$  is “complete”. This means that  $U$  contains infinitely many copies of all isomorphism classes of irreducible  $G$ -representations.<sup>1</sup>

We will use  $H$  to denote either the group  $G$  or its subgroups  $S^1$  or  $\{e\}$ . By restricting the  $G$ -action on  $U$ , we can also use  $U$  as a complete  $H$ -universe. We use  $\mathbf{R}_H$  to denote the set of all *finite-dimensional*  $H$ -representations contained in  $U$ . We will treat  $\mathbf{R}_G$  as a subset of  $\mathbf{R}_{S^1}$  and  $\mathbf{R}_{\{e\}}$  by restricting the  $G$ -action.

For any  $V \in \mathbf{R}_H$ , we use  $S^V$  to denote the 1-point compactification of  $V$  (called the representation sphere) and use  $S(V)$  to denote the unit sphere. We set  $\infty$  as the basepoint of  $S^V$  and we use  $S(V)_+$  to denote the union of  $S(V)$  with a disjoint basepoint.

Let  $X, Y$  and  $Z$  be based finite  $H$ -CW complexes; see for example [15, Chapter I] for a definition. We use the notation  $[X, Y]^H$  to denote the set of homotopy classes of based  $H$ -maps from  $X$  to  $Y$  (ie maps that preserve the basepoint and are equivariant under  $H$ ).

Given any  $V, W \in \mathbf{R}_H$  with  $V \subset W$ , let  $V^\perp$  be the orthogonal complement of  $V$  in  $W$ . Then smashing with the identity map on  $S^{V^\perp}$  provides a map

$$[S^V \wedge X, S^V \wedge Y]^H \rightarrow [S^W \wedge X, S^W \wedge Y]^H.$$

One can check that these maps make the collection

$$\{[S^V \wedge X, S^V \wedge Y]^H\}_{V \in \mathbf{R}_H}$$

into a direct system. We define  $\{X, Y\}^H$  as the direct limit of this system. As in the nonequivariant case, the set  $\{X, Y\}^H$  is actually an abelian group. A based  $H$ -map

$$S^V \wedge X \rightarrow S^V \wedge Y \quad \text{for } V \in \mathbf{R}_H$$

will be called a stable  $H$ -map from  $X$  to  $Y$ . An element in the group  $\{X, Y\}^H$  will be called a stable homotopy class of  $H$ -maps.

<sup>1</sup>Since all  $G$ -CW complexes we consider can have only  $G, S^1$  or  $\{e\}$  as their isotropy group, all arguments we make actually will still hold for the incomplete universe  $(\bigoplus_\infty \mathbb{R}) \oplus (\bigoplus_\infty \tilde{\mathbb{R}}) \oplus (\bigoplus_\infty \mathbb{H})$ , which is more relevant to the geometric setting.

**Fact 2.1** Given any based  $H$ -map  $f: X \rightarrow Y$ , we form the mapping cone  $Cf$  and let  $i: Y \rightarrow Cf$  be the natural inclusion. Then for any  $Z$ , the functor  $\{*, Z\}^H$  is a generalized cohomology theory [30, page 157]. As a result, there is a long exact sequence

$$(2) \quad \dots \rightarrow \{S^{\mathbb{R}} \wedge X, Z\}^H \xrightarrow{\partial} \{Cf, Z\}^H \xrightarrow{i^*} \{Y, Z\}^H \xrightarrow{f^*} \{X, Z\}^H \xrightarrow{\partial} \{Cf, S^{\mathbb{R}} \wedge Z\}^H \rightarrow \dots$$

associated to the cofiber sequence  $X \xrightarrow{f} Y \xrightarrow{i} Cf$ .

**Fact 2.2** Suppose the  $H$ -action on  $X$  is free away from the basepoint. Then there is a natural map

$$(3) \quad q_H: \{X, Y\}^H \rightarrow \{X/H, Y/H\}^{\{e\}}$$

from the equivariant homotopy group to the nonequivariant homotopy group of the quotient space. This map is constructed as follows: Since the  $H$ -action on  $X$  is free away from the basepoint, any  $[f] \in \{X, Y\}^H$  can be represented by an  $H$ -map  $f: S^V \wedge X \rightarrow S^V \wedge Y$  such that the  $H$ -action on  $V$  is trivial; see [1, Proposition 5.5; 28, Theorem 2.8, page 65]. The map  $f$  induces a nonequivariant map between the quotient space,

$$f/H: S^V \wedge (X/H) = (S^V \wedge X)/H \rightarrow (S^V \wedge Y)/H = S^V \wedge (Y/H).$$

Then we define  $q_H([f])$  as  $[f/H]$ . One can check that this does not depend on the choice of  $f$  and  $V$ .

**Fact 2.3** [1, Theorem 5.3; 28, Theorem 4.5, page 78] Suppose the  $H$ -action on  $X$  is free away from the basepoint and the  $H$ -action on  $Y$  is trivial. Then the map  $q_H$  is an isomorphism.

For the rest of the section, we assume  $X$  and  $Y$  are based finite  $G$ -CW complexes. The next few facts concern various relations between the  $G$ -equivariant homotopy groups and the  $S^1$ -equivariant homotopy groups.

**Fact 2.4** [1, Theorem 5.1; 28, Theorem 4.7, page 79] There is a natural isomorphism

$$(4) \quad \iota: \{X, Y\}^{S^1} \xrightarrow{\cong} \{X \wedge (S(\tilde{\mathbb{R}})_+), Y\}^G$$

constructed as follows: Take any  $[f] \in \{X, Y\}^{S^1}$  represented by an  $S^1$ -map

$$f: S^V \wedge X \rightarrow S^V \wedge Y.$$

By enlarging  $V$  if necessary, we may assume  $V \in \mathbf{R}_G$ . Then we consider the  $G$ -map

$$f': S^V \wedge X \wedge (S(\tilde{\mathbb{R}})_+) = ((S^V \wedge X) \times \{1\}) \vee ((S^V \wedge X) \times \{-1\}) \rightarrow Y$$

defined by setting

$$f'(x \times \{1\}) = f(x) \quad \text{and} \quad f'(x \times \{-1\}) = jf(j^{-1}x)$$

for any  $x \in S^V \wedge X$ . We let  $\iota([f]) = [f']$ . This map  $\iota$  turns out to be an isomorphism.

Next, we recall the two operations about changing groups, namely the restriction map

$$(5) \quad \text{Res}_{S^1}^G : \{X, Y\}^G \rightarrow \{X, Y\}^{S^1}$$

and the transfer map

$$(6) \quad \text{Tr}_{S^1}^G : \{X, Y\}^{S^1} \rightarrow \{X, Y\}^G.$$

The restriction map is defined by simply ignoring the  $j$ -action. To define the transfer map, we consider the Pontryagin–Thom map

$$p: S^{\tilde{\mathbb{R}}} \rightarrow S^{\tilde{\mathbb{R}}} \wedge S(\tilde{\mathbb{R}})_+$$

that crushes all points outside a normal neighborhood of  $S(\tilde{\mathbb{R}})$  in  $S^{\tilde{\mathbb{R}}}$ . (Here we identify the Thom space of the normal bundle of  $S(\tilde{\mathbb{R}})$  as  $S^{\tilde{\mathbb{R}}} \wedge (S(\tilde{\mathbb{R}})_+)$ .) Then the transfer map is defined as the composition

$$(7) \quad \{X, Y\}^{S^1} \xrightarrow{\iota} \{(S(\tilde{\mathbb{R}})_+) \wedge X, Y\}^G = \{S^{\tilde{\mathbb{R}}} \wedge (S(\tilde{\mathbb{R}})_+) \wedge X, S^{\tilde{\mathbb{R}}} \wedge Y\}^G \\ \xrightarrow{p^*} \{S^{\tilde{\mathbb{R}}} \wedge X, S^{\tilde{\mathbb{R}}} \wedge Y\}^G = \{X, Y\}^G.$$

To describe the composition of transfer and restriction, we define the conjugation map

$$(8) \quad c_j : \{X, Y\}^{S^1} \rightarrow \{X, Y\}^{S^1}$$

as follows: Take any element  $[f] \in \{X, Y\}^{S^1}$  represented by an  $S^1$ -map  $f: S^V \wedge X \rightarrow S^V \wedge Y$ . By enlarging  $V$  if necessary, we may assume  $V \in \mathbf{R}_G$ . Then  $c_j([f])$  is represented by the composition

$$S^V \wedge X \xrightarrow{j^{-1}} S^V \wedge X \xrightarrow{f} S^V \wedge Y \xrightarrow{j} S^V \wedge Y.$$

Note that when the  $S^1$ -action on  $X$  is free away from the basepoint, the maps  $c_j$  and the map  $q_{S^1}$  defined in (3) are compatible. That means

$$(9) \quad q_{S^1}(c_j(\alpha)) = j \circ q_{S^1}(\alpha) \circ j^{-1} \quad \text{for all } \alpha \in \{X, Y\}^{S^1}.$$

Here  $j$  and  $j^{-1}$  are treated as elements in  $\{Y/S^1, Y/S^1\}^{\{e\}}$  and  $\{X/S^1, X/S^1\}^{\{e\}}$ , respectively.

Next is a special case of the double coset formula [30, Chapter XVIII, Theorem 4.3]. It can be verified directly by unwinding the definitions.

**Fact 2.5** For any  $\alpha \in \{X, Y\}^{S^1}$ ,

$$(10) \quad \text{Res}_{S^1}^G \text{Tr}_{S^1}^G(\alpha) = \alpha + c_j(\alpha).$$

We end this subsection with an alternative description of the image of  $\text{Tr}_{S^1}^G$ :

**Lemma 2.6** Let  $e_{\tilde{\mathbb{R}}} \in \{S^0, S^{\tilde{\mathbb{R}}}\}^G$  be the element represented by the inclusion map

$$(11) \quad S^0 = \{0, \infty\} \hookrightarrow S^{\tilde{\mathbb{R}}}.$$

(This element is called the Euler class of  $\tilde{\mathbb{R}}$ .) Then the kernel of the map

$$(12) \quad \{X, Y\}^G \xrightarrow{e_{\tilde{\mathbb{R}}}} \{X, S^{\tilde{\mathbb{R}}} \wedge Y\}^G$$

equals the image of the transfer map (6).

**Proof** There is a cofiber sequence  $S^0 \hookrightarrow S^{\tilde{\mathbb{R}}} \xrightarrow{p} S^{\tilde{\mathbb{R}}} \wedge S(\tilde{\mathbb{R}})_+$ . Smashing this sequence with  $X$  and applying the functor  $\{*, S^{\tilde{\mathbb{R}}} \wedge Y\}^G$ , we get the exact sequence

$$\{(S^{\tilde{\mathbb{R}}} \wedge S(\tilde{\mathbb{R}})_+) \wedge X, S^{\tilde{\mathbb{R}}} \wedge Y\} \xrightarrow{p_*} \{S^{\tilde{\mathbb{R}}} \wedge X, S^{\tilde{\mathbb{R}}} \wedge Y\}^G \xrightarrow{e_{\tilde{\mathbb{R}}}} \{X, S^{\tilde{\mathbb{R}}} \wedge Y\}^G.$$

So we see that the image of  $p_*$  equals the kernel of the map (12). The lemma follows from the definition of  $\text{Tr}_{S^1}^G$ ; see (7). □

**2.1.2 The characteristic homomorphism** We now define the characteristic homomorphism

$$t: \{S^{a\mathbb{R}+b\mathbb{H}}, S^{d\tilde{\mathbb{R}}}\}^{S^1} \rightarrow \mathbb{Z},$$

following [11], where  $a, b$  and  $c$  are nonnegative integers with  $d \geq a + 2$ . This homomorphism is of interest to us because the (family) Seiberg–Witten invariant can be obtained by applying  $t$  on the Bauer–Furuta invariant. Note that although  $\tilde{\mathbb{R}}$  is trivial as an  $S^1$ –representation, we still distinguish it with  $\mathbb{R}$  in order to keep track of the  $j$ –action.

To define  $t$ , we take the smash product of the cofiber sequence

$$S^0 \rightarrow S^{b\mathbb{H}} \rightarrow S^{\mathbb{R}} \wedge S(b\mathbb{H})_+$$

with the sphere  $S^{a\mathbb{R}}$  and get the cofiber sequence

$$(13) \quad S^{a\mathbb{R}} \rightarrow S^{a\mathbb{R}+b\mathbb{H}} \rightarrow S^{(a+1)\mathbb{R}} \wedge S(b\mathbb{H})_+.$$

This induces the long exact sequence

$$(14) \quad \dots \rightarrow \{S^{(a+1)\mathbb{R}}, S^{d\tilde{\mathbb{R}}}\}^{S^1} \rightarrow \{S^{(a+1)\mathbb{R}} \wedge S(b\mathbb{H})_+, S^{d\tilde{\mathbb{R}}}\}^{S^1} \\ \rightarrow \{S^{a\mathbb{R}+b\mathbb{H}}, S^{d\tilde{\mathbb{R}}}\}^{S^1} \rightarrow \{S^{a\mathbb{R}}, S^{d\tilde{\mathbb{R}}}\}^{S^1} \rightarrow \dots$$

Since  $d \geq a + 2$ , the equivariant Hopf theorem [14, Section 8.4] states that the stable homotopy class of an  $S^1$ -equivariant stable map from  $S^{a\mathbb{R}}$  or  $S^{(a+1)\mathbb{R}}$  to  $S^{d\tilde{\mathbb{R}}}$  is determined by its mapping degree on the  $S^1$ -fixed point sets. Since this mapping degree is always 0 for dimension reasons,

$$\{S^{a\mathbb{R}}, S^{d\tilde{\mathbb{R}}}\}^{S^1} = \{S^{(a+1)\mathbb{R}}, S^{d\tilde{\mathbb{R}}}\}^{S^1} = 0.$$

Therefore, we get an isomorphism

$$(15) \quad \xi: \{S^{(a+1)\mathbb{R}} \wedge S(b\mathbb{H})_+, S^{d\tilde{\mathbb{R}}}\}^{S^1} \xrightarrow{\cong} \{S^{a\mathbb{R}+b\mathbb{H}}, S^{d\tilde{\mathbb{R}}}\}^{S^1}.$$

Note that the  $S^1$ -action on  $S^{(a+1)\mathbb{R}} \wedge S(b\mathbb{H})_+$  is free away from the basepoint, with quotient space  $S^{(a+1)\mathbb{R}} \wedge \mathbb{C}P_+^{2b-1}$ . By composing  $\xi^{-1}$  with the isomorphism  $q_{S^1}$  given in (3), we get the isomorphism

$$(16) \quad \psi = q_{S^1} \circ \xi^{-1}: \{S^{a\mathbb{R}+b\mathbb{H}}, S^{d\tilde{\mathbb{R}}}\}^{S^1} \xrightarrow{\cong} \{S^{(a+1)\mathbb{R}} \wedge \mathbb{C}P_+^{2b-1}, S^{d\tilde{\mathbb{R}}}\}^{\{e\}}.$$

**Definition 2.7** Suppose  $d - a$  is an odd number less than or equal to  $4b - 1$ . Then we define the characteristic homomorphism

$$t: \{S^{a\mathbb{R}+b\mathbb{H}}, S^{d\tilde{\mathbb{R}}}\}^{S^1} \rightarrow \mathbb{Z}$$

by setting  $t(\alpha)$  as the image of 1 under the induced map on the reduced cohomology

$$(\psi(\alpha))^*: \mathbb{Z} = \tilde{H}^d(S^{d\tilde{\mathbb{R}}}) \rightarrow \tilde{H}^d(S^{(a+1)\mathbb{R}} \wedge \mathbb{C}P_+^{2b-1}) \cong \mathbb{Z}.$$

Here we use the standard orientations on  $S^{d\tilde{\mathbb{R}}}$ ,  $S^{(a+1)\mathbb{R}}$  and  $\mathbb{C}P^{\frac{1}{2}(d-a-1)}$  to identify the homology groups as  $\mathbb{Z}$ . If either  $d - a$  is even or  $d - a > 4b - 1$ , we simply define  $t$  as the zero map.

To discuss the behavior of  $t$  under the conjugation map  $c_j$  defined in (8), we prove:

**Lemma 2.8** For any  $\alpha \in \{S^{a\mathbb{R}+b\mathbb{H}}, S^{d\tilde{\mathbb{R}}}\}^{S^1}$ ,

$$\psi(c_j(\alpha)) = (-1)^d m \circ \psi(\alpha),$$

where  $m \in \{\mathbb{C}P_+^{2b-1}, \mathbb{C}P_+^{2b-1}\}^{\{e\}}$  is the “mirror reflection map” defined as

$$m([z_1, z_2, z_3, z_4, \dots, z_{2b-1}, z_{2b}]) = ([-\bar{z}_2, \bar{z}_1, -\bar{z}_4, \bar{z}_3, \dots, -\bar{z}_{2b}, \bar{z}_{2b-1}]) \quad \text{for } z_i \in \mathbb{C}.$$

**Proof** By formula (9),  $\psi(c_j(\alpha))$  equals the composition of  $\psi(\alpha)$  with the elements

$$j \in \{S^{d\tilde{\mathbb{R}}}, S^{d\tilde{\mathbb{R}}}\{e\}$$

and

$$j^{-1} \in \{S^{(a+1)\mathbb{R}} \wedge \mathbb{C}P_+^{2b-1}, S^{(a+1)\mathbb{R}} \wedge \mathbb{C}P_+^{2b-1}\{e\},$$

which are just  $(-1)^d$  and a suspension of  $m$ , respectively. □

**Corollary 2.9** When  $d - a$  is odd,  $t(c_j(\alpha)) = (-1)^{\frac{1}{2}(3d-a-1)}t(\alpha)$  for any  $\alpha$ .

**Proof** When restricted to  $\mathbb{C}P^1$ , the map  $m$  is just the antipodal map, and so has degree  $-1$ . Using the ring structure on  $H^*(\mathbb{C}P^{2b-1})$ , we see that  $m$  has degree  $(-1)^{\frac{1}{2}(d-a-1)}$  on  $\tilde{H}^d(S^{(a+1)\mathbb{R}} \wedge \mathbb{C}P_+^{2b-1})$ . The result follows from Lemma 2.8. □

We end this section with the following result, which is essentially the algebraic version of the vanishing result for the Seiberg–Witten invariant of connected sums.

**Lemma 2.10** Given any  $\alpha_1 \in \{S^{a_1\mathbb{R}+b_1\mathbb{H}}, S^{d_1\tilde{\mathbb{R}}}\}S^1$  and  $\alpha_2 \in \{S^{a_2\mathbb{R}+b_2\mathbb{H}}, S^{d_2\tilde{\mathbb{R}}}\}S^1$ , we have  $t(\alpha_1\alpha_2) = 0$  if  $d_1 > a_1$  and  $d_2 > a_2$ .

**Proof** The product  $\alpha_1\alpha_2$  belongs to the group

$$\{S^{(a_1+a_2)\mathbb{R}+(b_1+b_2)\mathbb{H}}, S^{(d_1+d_2)\tilde{\mathbb{R}}}\}S^1.$$

Therefore,  $t(\alpha_1\alpha_2)$  can be nonzero only if  $d_1 + d_2 - a_1 - a_2$  is odd. Without loss of generality, we may assume  $d_1 - a_1$  is odd and  $d_2 - a_2$  is even. Since  $d_i > a_i$  for  $i = 1, 2$ , the group  $\{S^{a_i\mathbb{R}}, S^{d_i\tilde{\mathbb{R}}}\}S^1$  vanishes. By the long exact sequence (14), we see that  $\alpha_i$  equals the image of some element

$$\beta_i \in \{S^{(a_i+1)\mathbb{R}} \wedge S(b_i\mathbb{H})_+, S^{d_i\tilde{\mathbb{R}}}\}S^1 = \{S^{a_i\mathbb{R}} \wedge (S^{b_i\mathbb{H}}/S^0), S^{d_i\tilde{\mathbb{R}}}\}S^1.$$

Here we identify  $S^{b_i\mathbb{H}}/S^0$  with  $S^{\mathbb{R}} \wedge S(b_i\mathbb{H})_+$  by treating  $S^{\mathbb{R}}$  as the one-point compactification of  $(0, +\infty)$  and sending  $v \in \mathbb{H}^{b_i} \setminus \{0\}$  to  $(|v|, v/|v|) \in (0, \infty) \times S(b_i\mathbb{H})$ .

Next, we consider the commutative diagram

$$(17) \quad \begin{array}{ccc} S^{(b_1+b_2)\mathbb{H}} & \xrightarrow{q} & S^{(b_1+b_2)\mathbb{H}}/S^0 \\ \downarrow \cong & & \downarrow \gamma \\ S^{b_1\mathbb{H}} \wedge S^{b_2\mathbb{H}} & \xrightarrow{q_1 \wedge q_2} & (S^{b_1\mathbb{H}}/S^0) \wedge (S^{b_2\mathbb{H}}/S^0) \end{array}$$

where  $q, q_1, q_2$  and

$$\begin{aligned} \gamma: S^{(b_1+b_2)\mathbb{H}}/S^0 \\ \rightarrow S^{(b_1+b_2)\mathbb{H}}/((S^0 \wedge S^{b_2\mathbb{H}}) \cup (S^{b_1\mathbb{H}} \wedge S^0)) = (S^{b_1\mathbb{H}}/S^0) \wedge (S^{b_2\mathbb{H}}/S^0) \end{aligned}$$

are all quotient maps. From (17), we see that

$$\alpha_1 \wedge \alpha_2 = (\beta_1 \wedge \beta_2) \circ (q_1 \wedge q_2) = (\beta_1 \wedge \beta_2) \circ \gamma \circ q.$$

Therefore,  $\xi(\alpha_1\alpha_2) = (\beta_1\beta_2) \circ \gamma$ .

Moreover, checking the explicit construction of the map  $q_{S^1}$  given in Fact 2.2, we see that  $q_{S^1}$  is also natural under the smash product and composition. Therefore,

$$\psi(\alpha_1\alpha_2) = q_{S^1}(\xi(\alpha_1\alpha_2)) = q_{S^1}(\beta_1\beta_2) \circ q_{S^1}(\gamma),$$

and  $q_{S^1}(\beta_1\beta_2)$  equals the composition

$$\begin{aligned} S^{(a_1+a_2+2)\mathbb{R}} \wedge ((S(b_1\mathbb{H})_+ \wedge S(b_2\mathbb{H})_+)/S^1) \\ \rightarrow (S^{(a_1+1)\mathbb{R}} \wedge (S(b_1\mathbb{H})_+)/S^1) \wedge (S^{(a_2+1)\mathbb{R}} \wedge (S(b_2\mathbb{H})_+)/S^1) \\ \xrightarrow{q_{S^1}(\beta_1) \wedge q_{S^1}(\beta_2)} S^{d_1\mathbb{R}} \wedge S^{d_2\mathbb{R}}. \end{aligned}$$

Because  $d_2 - a_2$  is even, the cohomology  $\tilde{H}^{d_2}(S^{(a_2+1)\mathbb{R}} \wedge (S(b_2\mathbb{H})_+)/S^1)$  equals 0. So  $q_{S^1}(\beta_2)$  induces the trivial map on the reduced cohomology. This implies that  $\psi(\alpha_2\alpha_2)$  induces the trivial map on  $\tilde{H}^{d_1+d_2}(*).$  Hence,  $t(\alpha_1\alpha_2) = 0.$  □

## 2.2 The Pin(2)-equivariant Bauer–Furuta invariant for spin families

In this section, we briefly summarize the definition and some important properties of the Bauer–Furuta invariant for spin families. This invariant was originally defined in [11] for a single 4–manifold. The family version was first defined in [35; 38] and later extensively studied in [7; 9]. Because we want to construct the Bauer–Furuta invariant as a concrete element in the  $G$ –equivariant stable homotopy group of spheres, some care must be taken in the construction.

**2.2.1 Spin structures on the circle family of 4–manifolds** Let  $N$  be a smooth fiber bundle whose fiber is a closed spin 4–manifold  $M$  and whose base is another closed manifold  $B$ . For simplicity, we will make the following assumption throughout the paper:

**Assumption 2.11** The bundle  $N$  satisfies:

- (i)  $M$  is simply connected.



- (ii) The signature  $\sigma(M)$  is at most 0.
- (iii) Let  $M_x$  be the fiber over the point  $x \in B$ . Then the action of  $\pi_1(B, x)$  on  $H^2(M_x; \mathbb{Z})$  (given by the holonomy of the bundle) is trivial.

We equip  $N$  with a Riemannian metric and let  $\text{Fr}^v(N)$  be the frame bundle of the vertical tangent bundle of  $N$ . This is an  $\text{SO}(4)$ -bundle over  $N$ .

**Definition 2.12** A spin structure  $\mathfrak{s}$  on  $N$  is a double covering map  $\pi : P \rightarrow \text{Fr}^v(N)$  that restricts to a nontrivial covering map  $\text{Spin}(4) \rightarrow \text{SO}(4)$  on each fiber. Two spin structures  $(\pi, P)$  and  $(\pi', P')$  are called isomorphic if there exists a homeomorphism  $P \rightarrow P'$  that covers the identity map on  $\text{Fr}^v(N)$ .

**Definition 2.13** The pair  $(N, \mathfrak{s})$  is called a spin family. Two spin families  $(N_1, \mathfrak{s}_1)$  and  $(N_2, \mathfrak{s}_2)$  over the same base  $B$  are called “isomorphic” if there exists a bundle isomorphism  $f : N_1 \rightarrow N_2$  such that  $f^*(\mathfrak{s}_2)$  is isomorphic to  $\mathfrak{s}_1$ .

We are mainly interested in the case that  $B$  is a circle or a point. By Assumption 2.11,  $N$  has a unique spin structure when  $B$  is a point and has two spin structures when  $B$  is a circle. We give an explicit description of these two spin structures as follows: Let  $\pi_M : P_M \rightarrow \text{Fr}(M)$  be the covering map given by the unique spin structure on  $M$ . Then the bundle  $N$  is obtained by gluing the two boundary components of  $M \times [0, 1]$  via a diffeomorphism  $f : M \rightarrow M$ . The diffeomorphism induces a map  $f_* : \text{Fr}(M) \rightarrow \text{Fr}(M)$ , which has two lifts  $f_*^\pm : P_M \rightarrow P_M$ . These lifts differ from each other by the deck transformation  $\tau : P_M \rightarrow P_M$ . We use  $f_*^\pm$  to glue the two boundary components of  $P_M \times I$  and form two spin structures on  $N$ .

**Definition 2.14** When  $N = M \times S^1$ , the maps  $f_*^\pm$  are just the identity map and the deck transformation  $\tau$ . We call the associated spin structures over  $N$  the *product spin structure* and the *twisted spin structure*, respectively. Let  $\mathfrak{s}$  be the unique spin structure on  $M$ . Then we use  $\tilde{\mathfrak{s}}$  to denote the former and use  $\tilde{\mathfrak{s}}^\tau$  to denote the latter.

For general  $M$ , the product family and the twisted family are not isomorphic. For example, Kronheimer and Mrowka [26] established:

**Example 2.15** The product family  $(K3 \times S^1, \tilde{\mathfrak{s}})$  and the twisted family  $(K3 \times S^1, \tilde{\mathfrak{s}}^\tau)$  are not isomorphic, as can be proved by the nonequivariant Bauer–Furuta invariant.

However, for the special case of  $S^2 \times S^2$ , these two families are indeed isomorphic:

**Lemma 2.16**  $((S^2 \times S^2) \times S^1, \tilde{\xi})$  and  $((S^2 \times S^2) \times S^1, \tilde{\xi}^\tau)$  are isomorphic.

**Proof** There is an  $S^1$ -action on  $S^2$  with fixed points  $\{0, \infty\}$ . We use  $\xi: S^1 \times S^2 \rightarrow S^2$  to denote this action. As  $x$  varies from 0 to  $2\pi$ , the induced map

$$(\text{id}_{S^2} \times \xi(x, \cdot))_*: T_{(0,0)}(S^2 \times S^2) \rightarrow T_{(0,0)}(S^2 \times S^2)$$

gives an essential loop in  $\text{SO}(4)$ . Using this fact, one can verify that the bundle automorphism

$$f: (S^2 \times S^2) \times S^1 \rightarrow (S^2 \times S^2) \times S^1$$

defined by  $f(y_1, y_2, x) = (y_1, \xi(x, y_2), x)$  satisfies  $f^*(\tilde{\xi}) = \tilde{\xi}^\tau$ . □

**2.2.2 Definition of the Bauer–Furuta invariant** As in the case of a single 4-manifold, a spin structure  $\mathfrak{s}$  gives rise to two quaternion bundles  $S^\pm$  over  $N$ . Denote by  $S_x^\pm$  the restriction of  $S^\pm$  to the fiber  $M_x$ . Then the spin Dirac operator

$$D(M_x): \Gamma(S_x^+) \rightarrow \Gamma(S_x^-)$$

is a quaternionic linear operator. We form the operator  $D$  over  $N$  by putting  $D(M_x)$  together.

Now we consider four Hilbert bundles  $\mathcal{V}^+, \mathcal{V}^-, \mathcal{U}^+$  and  $\mathcal{U}^-$  over  $B$ . The fibers of  $\mathcal{V}^\pm$  are suitable Sobolev completions of  $\Gamma(S_x^\pm)$ , and the fibers of  $\mathcal{U}^+$  and  $\mathcal{U}^-$  are completions of  $\Omega^1(M_x)$  and  $\Omega^2_+(M_x) \oplus \Omega^0(M_x)/\mathbb{R}$ , respectively. We let  $G = \text{Pin}(2)$  act on  $\mathcal{V}^\pm$  by left multiplication in the quaternions, and we let  $G$  act on  $\mathcal{U}^\pm$  by setting the  $S^1$ -action to be trivial and setting the  $j$ -action as multiplication by  $-1$ .

The family Seiberg–Witten equations give a fiber-preserving  $G$ -equivariant map

$$SW: \mathcal{U}^+ \oplus \mathcal{V}^+ \rightarrow \mathcal{U}^- \oplus \mathcal{V}^-.$$

This Seiberg–Witten map can be written as  $l + c$ , where  $l$  is the fiberwise Fredholm operator

$$l := D \oplus (d^+, d^*)$$

and  $c$  is a certain 0<sup>th</sup> order operator. Furthermore, by the boundedness property of the Seiberg–Witten equations [11, Proposition 3.1],  $SW$  extends to a map

$$SW^+: (\mathcal{U}^+ \oplus \mathcal{V}^+)_\infty \rightarrow (\mathcal{U}^- \oplus \mathcal{V}^-)_\infty$$

between the one-point completions

$$(\mathcal{U}^\pm \oplus \mathcal{V}^\pm)_\infty := (\mathcal{U}^\pm \oplus \mathcal{V}^\pm) \cup \{\infty\}.$$

To apply the finite-dimensional approximation technique on the map  $\mathcal{SW}$ , we carefully choose finite-dimensional subspaces of  $\mathcal{V}^\pm$  and  $\mathcal{U}^\pm$  as follows: First, we apply Kuiper’s theorem [27] to get canonical trivialization of the bundles

$$(18) \quad \mathcal{V}^- \cong B \times L^2(\mathbb{H}^\infty) \quad \text{and} \quad \mathcal{U}^+ \cong B \times L^2(\tilde{\mathbb{R}}^\infty).$$

Here  $L^2(*)$  denotes the completion with respect to the  $L^2$ -norm. Choose  $m, n \gg 0$  and let  $U^+ \subset \mathcal{U}^+$  and  $V^- \subset \mathcal{V}^-$  be the subbundles corresponding to the bundles  $B \times \mathbb{H}^n$  and  $B \times \tilde{\mathbb{R}}^m$  under the isomorphism (18). Let  $H_2^+$  be the subbundle of  $\mathcal{U}^-$  consisting of all self-dual harmonic 2-forms on  $M_x$ . We set

$$U^- := H_2^+ \oplus ((d^+, d^*)U^+) \subset \mathcal{U}^-.$$

(Note that  $(d^+, d^*)$  is injective by our assumption that  $b_1(M) = 0$ .) We choose  $m$  large enough so that  $V^-$  is fiberwise transverse to  $D$  and we set  $V^+ := D^{-1}(V^-) \subset \mathcal{V}^+$ .

Set  $W^+ := U^+ \oplus V^+$  and  $W^- := U^- \oplus V^-$ . As explained in [11], when  $m$  and  $n$  are large enough,

$$S\mathcal{W}^+(W_\infty^+) \cap S(W^{-,\perp}) = \emptyset,$$

where  $S(W^{-,\perp})$  denotes the unit sphere in the orthogonal complement of  $W^-$  in  $\mathcal{U}^- \oplus \mathcal{V}^-$ . Therefore, by composing  $\mathcal{SW}^+$  with a specific  $G$ -equivariant deformation retraction

$$\rho: (\mathcal{U}^- \oplus \mathcal{V}^-)_\infty \setminus S(W^{-,\perp}) \rightarrow W_\infty^-,$$

one obtains a  $G$ -equivariant map

$$\text{sw}: W_\infty^+ \rightarrow W_\infty^-.$$

Restriction of (18) gives canonical trivializations of the bundles  $V^-$  and  $U^+$ . By Assumption 2.11,  $\pi_1(B)$  acts trivially on  $H^2(M_x)$ . Therefore, as explained in [26], a homology orientation of  $M$  determines a canonical trivialization of  $H_2^+$ . At this point, we have obtained canonical trivializations of  $U^\pm$  and  $V^-$ . Using these trivializations, we get the composition map

$$(19) \quad (S^{m\tilde{\mathbb{R}}} \wedge V_\infty^+) \cong W_\infty^+ \xrightarrow{\text{sw}} W_\infty^- \cong (S^{(m+b^+(M))\tilde{\mathbb{R}}+n\mathbb{H}} \wedge B_+) \xrightarrow{pj} S^{(m+b^+(M))\tilde{\mathbb{R}}+n\mathbb{H}},$$

where  $pj$  denotes projection to the first factor.

From now on, we specialize to the case that  $B$  is a circle or point. Note that  $V^+$  is a quaternionic bundle of dimension  $n - \frac{1}{16}\sigma(M)$  and the group  $\text{Sp}(n - \frac{1}{16}\sigma(M))$  has

trivial  $\pi_i$  for  $i \leq 2$ . So the bundle  $V^+$  has a trivialization (canonical up to homotopy). This trivialization allows us to fix an identification

$$V_\infty^+ \cong (S^{(n-\sigma(M)/16)\mathbb{H}} \wedge B_+)$$

and rewrite the map (19) as a  $G$ -map

$$(20) \quad \tilde{s}\tilde{w}: S^{m\tilde{\mathbb{R}}+(n-\sigma(M)/16)\mathbb{H}} \wedge B_+ \rightarrow S^{(m+b^+(M))\tilde{\mathbb{R}}+n\mathbb{H}},$$

which represents an element in  $[\tilde{s}\tilde{w}] \in \{S^{-(\sigma(M)/16)\mathbb{H}} \wedge B_+, S^{b^+(M)\tilde{\mathbb{R}}}\}^G$ . By checking the concrete construction of  $\tilde{s}\tilde{w}$  in [11], one establishes:

**Fact 2.17** Consider the map  $S^{m\tilde{\mathbb{R}}} \wedge B_+ \rightarrow S^{(m+b^+(M))\tilde{\mathbb{R}}}$  given by restricting  $\tilde{s}\tilde{w}$  to the  $S^1$ -fixed point sets. This map can be explicitly described as the composition

$$S^{m\tilde{\mathbb{R}}} \wedge B_+ \xrightarrow{\text{projection}} S^{m\tilde{\mathbb{R}}} \xrightarrow{\text{inclusion}} S^{(m+b^+(M))\tilde{\mathbb{R}}}.$$

**Definition 2.18** Suppose  $B$  is a point. Then  $M = N$  and  $S^{-(\sigma(M)/16)\mathbb{H}} \wedge B_+ = S^{-(\sigma(M)/16)\mathbb{H}}$ . In this case, we define the  $G$ -equivariant Bauer–Furuta invariant as

$$\text{BF}^G(M, \mathfrak{s}) := [\tilde{s}\tilde{w}] \in \{S^{-(\sigma(M)/16)\mathbb{H}}, S^{b^+(M)\tilde{\mathbb{R}}}\}^G.$$

We will neglect the spin structure  $\mathfrak{s}$  in our notation when it is obvious from the context.

**Example 2.19**  $\text{BF}^G(S^4)$  is an element in  $\{S^0, S^0\}^G$  represented by a  $G$ -map from the  $S^{m\tilde{\mathbb{R}}+n\mathbb{H}}$  to itself. By the equivariant Hopf theorem [15, Chapter II.4], such a stable homotopy class is determined by its restriction to the  $S^1$ -fixed points. Hence, by Fact 2.17, we see that  $\text{BF}^G(S^4) = 1$ .

**Example 2.20**  $\text{BF}^G(S^2 \times S^2) \in \{S^0, S^{\tilde{\mathbb{R}}}\}^G$  is represented by a  $G$ -map from  $S^{m\tilde{\mathbb{R}}+n\mathbb{H}}$  to  $S^{(m+1)\tilde{\mathbb{R}}+n\mathbb{H}}$ . Such a map is also determined by its restriction on the  $S^1$ -fixed points. By Fact 2.17 again, we see that  $\text{BF}^G(S^2 \times S^2) = e_{\tilde{\mathbb{R}}}$ . Here  $e_{\tilde{\mathbb{R}}}$  is the Euler class defined in (11).

When  $B$  is a circle, we identify it with the unit sphere  $S(2\mathbb{R})$  in  $S^{2\mathbb{R}}$ . Consider the cofiber sequence

$$(21) \quad S(2\mathbb{R}) \cup \{\infty\} \rightarrow S^0 \rightarrow S^{2\mathbb{R}} \xrightarrow{p} S^{\mathbb{R}} \wedge (S(2\mathbb{R}) \cup \{\infty\}).$$

The map  $p$ , which is just the Pontryagin–Thom map for the inclusion  $S(2\mathbb{R}) \hookrightarrow S^{2\mathbb{R}}$ , can be treated as a stable map from  $S^{\mathbb{R}}$  to  $B_+$ . This stable map induces the map

$$p^*: \{S^{-(\sigma(M)/16)\mathbb{H}} \wedge B_+, S^{b^+(M)\tilde{\mathbb{R}}}\}^G \rightarrow \{S^{\mathbb{R}-(\sigma(M)/16)\mathbb{H}}, S^{b^+(M)\tilde{\mathbb{R}}}\}^G$$

that sends  $\alpha$  to  $\alpha \circ (\text{id}_{S^{-(\sigma(M)/16)\mathbb{H}}} \wedge p)$ .

**Definition 2.21** When  $B = S(2\mathbb{R})$  we define the  $G$ -equivariant Bauer–Furuta invariant

$$BF^G(N, \mathfrak{s}) := p^*[\widetilde{sw}] \in \{S^{\mathbb{R}-(\sigma(M)/16)\mathbb{H}}, S^{b^+(M)\widetilde{\mathbb{R}}}\}^G.$$

In either case, we define both the  $S^1$ -equivariant and nonequivariant Bauer–Furuta invariants as the restriction of the  $G$ -equivariant Bauer–Furuta invariant:

$$BF^{S^1}(N, \mathfrak{s}) := \text{Res}_{S^1}^G(BF^G(N, \mathfrak{s})),$$

$$BF^{\{e\}}(N, \mathfrak{s}) := \text{Res}_{\{e\}}^G(BF^G(N, \mathfrak{s})).$$

In [26], Kronheimer and Mrowka gave an alternative definition of  $BF^{\{e\}}(N, \mathfrak{s})$ : Take a generic section  $r$  of the bundle  $W^-$  that is transverse to the map  $sw$ . Then the preimage  $sw^{-1}(r)$  is a manifold. When  $B$  is a point, the canonical trivializations of the bundles  $W^\pm$  determine a stable framing on  $sw^{-1}(r)$ . When  $B$  is  $S(2\mathbb{R})$ , we fix a stable framing on  $B$  that bounds a framed disk. Then together with the trivializations of  $W^\pm$ , this determines a stable framing on  $sw^{-1}(r)$ . In [26], the family Bauer–Furuta invariant is defined as the framed cobordism class of  $sw^{-1}(r)$ .

Recall that the framed cobordism classes of smooth  $n$ -manifolds are classified by elements in the  $n^{\text{th}}$  stable homotopy group of spheres. The following lemma states that our definition of  $BF^{\{e\}}$  is essentially identical to Kronheimer and Mrowka’s definition.

**Lemma 2.22** *The framed cobordism class of  $sw^{-1}(r)$  is classified by the nonequivariant Bauer–Furuta invariant  $BF^{\{e\}}(N, \mathfrak{s})$ .*

**Proof** By Sard’s theorem, we can take  $r$  to be a constant section that sends the whole  $B$  to a generic point  $r_0 \in S^{(m+b^+(M))\widetilde{\mathbb{R}}+n\mathbb{H}}$ . Then  $sw^{-1}(r) = \widetilde{sw}^{-1}(r_0)$  and it is also the preimage of the point

$$\{0\} \times r_0 \in S^{\mathbb{R}+(m+b^+(M))\widetilde{\mathbb{R}}+n\mathbb{H}}$$

under the composition

$$(22) \quad (\text{id}_{S^{\widetilde{\mathbb{R}}}} \wedge \widetilde{sw}) \circ (\text{id}_{S^{(n-\sigma(M)/16)\mathbb{H}+m\widetilde{\mathbb{R}}}} \wedge p) : S^{2\mathbb{R}+m\widetilde{\mathbb{R}}+(n-\sigma(M)/16)\mathbb{H}} \rightarrow S^{\mathbb{R}+(m+b^+(M))\widetilde{\mathbb{R}}+n\mathbb{H}}.$$

Because  $r_0$  is a regular value of  $\widetilde{sw}$  and any point in  $\{0\} \times B_+$  is a regular value of  $p$ , we see that  $\{0\} \times r_0$  is indeed a regular value of the map (22). Recall that an element in the stable group of spheres defines a stably framed manifold by taking the preimage of a regular value and taking the induced framing. The proof is finished by observing that the stable framing on  $B$  that bounds a framed disk (the one we used to fix the framing on  $sw^{-1}(r)$ ) is exactly the framing induced by the inclusion  $B \hookrightarrow S^{2\mathbb{R}}$ .  $\square$

**2.2.3 Some properties of the Bauer–Furuta invariant** In this subsection, we summarize some important properties of the Bauer–Furuta invariant. We start with a vanishing result. Recall from Definition 2.14 that on the trivial bundle  $N = M \times S^1$  there are two spin structures: the product spin structure  $\tilde{s}$  and the twisted spin structure  $\tilde{s}^\tau$ .

**Lemma 2.23** *The Bauer–Furuta invariants  $BF^G$ ,  $BF^{S^1}$  and  $BF^{\{e\}}$  of the product spin structure  $\tilde{s}$  are all vanishing.*

**Proof** The cofiber sequence (21) induces a long exact sequence

$$\begin{aligned} \dots \rightarrow \{S^{-(\sigma(M)/16)\mathbb{H}}, S^{b^+(M)\tilde{\mathbb{R}}}\}^G \xrightarrow{q^*} \{S^{-(\sigma(M)/16)\mathbb{H}} \wedge B_+, S^{b^+(M)\tilde{\mathbb{R}}}\}^G \\ \xrightarrow{p^*} \{S^{\mathbb{R}-(\sigma(M)/16)\mathbb{H}}, S^{b^+(M)\tilde{\mathbb{R}}}\}^G \rightarrow \dots, \end{aligned}$$

where  $q^*$  is induced by the map  $q: B_+ \rightarrow S^0$  that preserves the basepoint and sends  $B$  to the other point. By its definition, the map  $\tilde{s}\tilde{w}$  for  $(M \times S^1, \tilde{s})$  is just a pullback of the corresponding map for  $(M, \mathfrak{s})$  via the map  $q$ . So  $[\tilde{s}\tilde{w}] \in \text{Image}(q^*)$ , which implies

$$BF^G((M \times S^1, \tilde{s})) = p^*([\tilde{s}\tilde{w}]) = 0.$$

The invariants  $BF^{S^1}$  and  $BF^{\{e\}}$  vanish because  $BF^G$  vanishes. □

Regarding the Bauer–Furuta invariant of the twisted spin structure, Kronheimer and Mrowka [26] proved the following result by studying the stable framing on the moduli space:

**Proposition 2.24** *We have*

$$(23) \quad BF^{\{e\}}(M \times S^1, \tilde{s}^\tau) = \begin{cases} \eta \cdot BF^{\{e\}}(M, \mathfrak{s}) & \text{when } \sigma(M) \equiv 16 \pmod{32}, \\ 0 & \text{when } 32 \mid \sigma(M). \end{cases}$$

Here  $\eta \in \{S^{\mathbb{R}}, S^0\}^{\{e\}}$  denotes the Hopf map.

**Remark** It would be interesting to prove a generalization of Proposition 2.24 for  $BF^G(M \times S^1, \tilde{s}^\tau)$  and  $BF^{S^1}(M \times S^1, \tilde{s}^\tau)$ .

Next, we give a connected sum formula for the family Bauer–Furuta invariants. This formula was originally proved by Bauer [10] for a single 4–manifold.

To set up the theorem we let  $(N_i, \mathfrak{s}_i)$  for  $i = 1, 2$  be two spin families over  $B = S(2\mathbb{R})$  with fiber  $M_i$ , both satisfying Assumption 2.11. To form the connected sum, we pick sections  $\gamma_i: B \rightarrow N_i$ . By Assumption 2.11(i), the section  $\gamma_i$  is unique up to

homotopy. We remove small standard 4–balls around these sections to form the family  $N_i - D^4 \times S^1$  of 4–manifolds with boundary. Then we can form the fiberwise connected sum by identifying the collars of their boundaries. To fix such an identification, we need to choose a smooth family of orientation reversing isomorphisms

$$\tilde{\phi} := \{\phi_x : T_{\gamma_1(x)}(M_1)_x \xrightarrow{\cong} T_{\gamma_2(x)}(M_2)_x\}_{x \in B}.$$

We use  $N_1 \#_{\tilde{\phi}} N_2$  to denote the resulting bundle over  $B$ , with fiber  $M_1 \# M_2$ . In general, the result  $N_1 \#_{\tilde{\phi}} N_2$  will depend on the choice of  $\tilde{\phi}$  up to homotopy. Because  $\pi_1(\text{SO}(4)) = \mathbb{Z}/2$ , there are essentially two choices.

**Lemma 2.25** *There exists exactly one choice of  $\tilde{\phi}$  such that the spin structures  $\mathfrak{s}_1$  and  $\mathfrak{s}_2$  can be glued together to form a spin structure on  $N_1 \#_{\tilde{\phi}} N_2$ . We denote this choice by  $\tilde{\phi}(\mathfrak{s}_1, \mathfrak{s}_2)$  and denote the resulting spin structure by  $\mathfrak{s}_1 \# \mathfrak{s}_2$ .*

**Proof** Denote by  $\tilde{\phi}^{\pm}$  the two choices of  $\tilde{\phi}$ . Then they provide gluing maps

$$f^{\pm} : \partial(N_1 - D^4 \times S^1) \rightarrow \partial(N_2 - D^4 \times S^1),$$

which differ from each other by a Dehn twist on  $\partial(N_2 - D^4 \times S^1)$ . Under any boundary parametrization  $\partial(N_2 - D^4 \times S^1) \cong S^3 \times S^1$ , this Dehn twist can be written as

$$\iota(v, x) = (\alpha(x)v, x) \quad \text{for } (v, x) \in S^3 \times S^1,$$

where  $\alpha : S^1 \rightarrow \text{SO}(4)$  is an essential loop. Note that  $S^3 \times S^1$ , regarded as the product  $S^3$ –bundle over  $S^1$ , has two family spin structures (the product spin structure and the twisted spin structure), which are related to each other by  $\iota$ . We see that exactly one of the two maps  $f^{\pm}$  sends  $\mathfrak{s}_1|_{\partial(N_1 - D^4 \times S^1)}$  to  $\mathfrak{s}_2|_{\partial(N_2 - D^4 \times S^1)}$ . This finishes the proof. We also note that when  $\tilde{\phi} = \tilde{\phi}(\mathfrak{s}_1, \mathfrak{s}_2)$ , the gluing map on the boundary has two lifts to the gluing map on the spin bundle, but they give isomorphic spin structures on the connected sum. □

From the discussion above, there is a unique way to take the connected sum of two spin families  $(N_i, \mathfrak{s}_i)$ . The resulting spin family  $(N_1 \#_{\tilde{\phi}(\mathfrak{s}_1, \mathfrak{s}_2)} N_2, \mathfrak{s}_1 \# \mathfrak{s}_2)$  will also be written as  $(N_1, \mathfrak{s}_1) \# (N_2, \mathfrak{s}_2)$ .

To talk about the Bauer–Furuta invariant of a connected sum, we also need to specify a rule for homology orientation. Given homology orientations on  $M_1$  and  $M_2$ , we let the homology orientation on  $M_1 \# M_2$  be defined by putting the oriented basis for  $H_+^2(M_1)$  in front of the oriented basis for  $H_+^2(M_2)$ . The following theorem is a family version of Bauer’s connected sum formula [10]:

**Proposition 2.26** *Let  $(M \times S^1, \tilde{s})$  be the product family for some spin 4–manifold  $(M, \mathfrak{s})$ . Then*

$$\mathrm{BF}^H((N_1, \mathfrak{s}_1) \# (M \times S^1, \tilde{s})) = \mathrm{BF}^H(N_1, \mathfrak{s}_1) \wedge \mathrm{BF}^H(M, \mathfrak{s})$$

for  $H = G, S^1$  or  $\{e\}$ .

**Proof** The proof is essentially identical to the single 4–manifold case in [10]; see [26] for a sketch of the proof for the family version (in the nonequivariant setting). A central step is an excision argument that builds a homotopy between the approximated Seiberg–Witten maps  $\tilde{sw}$  (20) for the bundle

$$N_1 \cup (M \times S^1) \cup (S^4 \times S^1)$$

viewed as a family over  $S^1$  with fiber  $M_1 \cup M \cup S^4$ , and the bundle

$$(N \# (M \times S^1) \cup (S^4 \times S^1)) \cup (S^4 \times S^1),$$

viewed as a family over  $S^1$  with fiber  $(M_1 \# M) \cup S^4 \cup S^4$ . This homotopy is constructed by multiplying various sections by scalar-valued real cutoff functions and applying various terms in the Seiberg–Witten map, which are all  $G$ –equivariant. Therefore, this homotopy is  $G$ –equivariant.  $\square$

As a corollary, we get the following result, which computes the Bauer–Furuta invariant under family stabilization:

**Corollary 2.27** *Consider the product spin structure  $\tilde{s}_0$  and the twisted spin structure  $\tilde{s}_0^\tau$  over the product bundle  $((S^2 \times S^2) \times S^1)$ . Then, for any spin family  $(N, \mathfrak{s})$  that satisfies Assumption 2.11,*

$$(24) \quad \mathrm{BF}^G((N, \mathfrak{s}) \# (((S^2 \times S^2) \times S^1), \tilde{s}_0)) = \mathrm{BF}^G(N, \mathfrak{s}) \cdot e_{\mathbb{R}}$$

and

$$(25) \quad \mathrm{BF}^G((N, \mathfrak{s}) \# (((S^2 \times S^2) \times S^1), \tilde{s}_0^\tau)) = \mathrm{BF}^G(N, \mathfrak{s}) \cdot e_{\mathbb{R}}.$$

Here  $e_{\mathbb{R}} \in \{S^0, S^{\mathbb{R}}\}^G$  is the Euler class defined in (11).

**Proof** The formula (24) follows from Proposition 2.26 and Example 2.20. The formula (25) follows from (24) and Lemma 2.16.  $\square$



### 3 Proof of the main theorem

#### 3.1 The key proposition

In this subsection, we prove the homotopy theoretic Proposition 3.2, which will be the key ingredient in the proof of our main theorem.

Recall that the group  $\{S^{\mathbb{R}+2\mathbb{H}}, S^{6\tilde{\mathbb{R}}}\}S^1$  admits a conjugation action  $c_j$ ; see (8). The following lemma computes this group and this action:

**Lemma 3.1** *The characteristic homomorphism  $t: \{S^{\mathbb{R}+2\mathbb{H}}, S^{6\tilde{\mathbb{R}}}\}S^1 \rightarrow \mathbb{Z}$  is surjective and has  $\ker t = \mathbb{Z}/2$ . The conjugation action  $c_j$  acts trivially on  $\ker t$ .*

**Proof** Smashing the cofiber sequence  $S^0 \rightarrow S^{2\mathbb{H}} \rightarrow S^{\mathbb{R}} \wedge (S(2\mathbb{H})_+)$  with  $S^{\mathbb{R}}$ , we get a cofiber sequence  $S^{\mathbb{R}} \rightarrow S^{\mathbb{R}+2\mathbb{H}} \rightarrow S^{2\mathbb{R}} \wedge (S(2\mathbb{H})_+)$ , which induces the long exact sequence

$$\begin{aligned} \dots \rightarrow \{S^{2\mathbb{R}}, S^{6\tilde{\mathbb{R}}}\}S^1 &\rightarrow \{S^{2\mathbb{R}} \wedge (S(2\mathbb{H})_+), S^{6\tilde{\mathbb{R}}}\}S^1 \\ &\rightarrow \{S^{\mathbb{R}+2\mathbb{H}}, S^{6\tilde{\mathbb{R}}}\}S^1 \rightarrow \{S^{\mathbb{R}}, S^{6\tilde{\mathbb{R}}}\}S^1 \rightarrow \dots \end{aligned}$$

By the equivariant Hopf theorem [15, Chapter II.4],  $\{S^{\mathbb{R}}, S^{6\tilde{\mathbb{R}}}\}S^1 = \{S^{2\mathbb{R}}, S^{6\tilde{\mathbb{R}}}\}S^1 = 0$ . Hence, we get the isomorphism

$$\{S^{\mathbb{R}+2\mathbb{H}}, S^{6\tilde{\mathbb{R}}}\}S^1 \cong \{S^{2\mathbb{R}} \wedge (S(2\mathbb{H})_+), S^{6\tilde{\mathbb{R}}}\}S^1.$$

Note that the  $S^1$ -action on  $S^{2\mathbb{R}} \wedge (S(2\mathbb{H})_+)$  is free away from the basepoint. By Fact 2.3,

$$\{S^{2\mathbb{R}} \wedge (S(2\mathbb{H})_+), S^{6\tilde{\mathbb{R}}}\}S^1 = \{S^{2\mathbb{R}} \wedge (\mathbb{C}P^3_+), S^{6\tilde{\mathbb{R}}}\}\{e\}.$$

The cofiber sequence  $\mathbb{C}P^1_+ \rightarrow \mathbb{C}P^3_+ \rightarrow \mathbb{C}P^3/\mathbb{C}P^1$  induces the exact sequence

$$\begin{aligned} \{S^{3\mathbb{R}} \wedge (\mathbb{C}P^1_+), S^{6\tilde{\mathbb{R}}}\}\{e\} &\rightarrow \{S^{2\mathbb{R}} \wedge (\mathbb{C}P^3_+), S^{6\tilde{\mathbb{R}}}\}\{e\} \\ &\rightarrow \{S^{2\mathbb{R}} \wedge (\mathbb{C}P^3/\mathbb{C}P^1), S^{6\tilde{\mathbb{R}}}\}\{e\} \rightarrow \{S^{2\mathbb{R}} \wedge (\mathbb{C}P^1_+), S^{6\tilde{\mathbb{R}}}\}\{e\}. \end{aligned}$$

By the cellular approximation theorem,

$$\{S^{3\mathbb{R}} \wedge (\mathbb{C}P^1_+), S^{6\tilde{\mathbb{R}}}\}\{e\} = \{S^{2\mathbb{R}} \wedge (\mathbb{C}P^1_+), S^{6\tilde{\mathbb{R}}}\}\{e\} = 0.$$

So we obtain the isomorphism

$$\{S^{2\mathbb{R}} \wedge (\mathbb{C}P^3_+), S^{6\tilde{\mathbb{R}}}\}\{e\} \cong \{S^{2\mathbb{R}} \wedge (\mathbb{C}P^3/\mathbb{C}P^1), S^{6\tilde{\mathbb{R}}}\}\{e\}.$$

To understand the stable homotopy type of  $\mathbb{C}P^3/\mathbb{C}P^1$  as a nonequivariant space, we let  $x$  be the generator of  $H^2(\mathbb{C}P^3; \mathbb{Z}/2)$ . Then the total Steenrod square is given by

$$\text{Sq}(x) = \text{Sq}^0(x) + \text{Sq}^2(x) = x + x^2.$$

By the Cartan formula,

$$\text{Sq}(x^2) = (x + x^2)^2 = x^2 \in H^*(\mathbb{C}P^3; \mathbb{Z}/2).$$

In particular,  $\text{Sq}^2(x^2) = 0$ , which implies that the attaching map between the 6–cell and the 4–cell in  $\mathbb{C}P^3$ , regarded as an element in the stable homotopy group  $\pi_1 = \mathbb{Z}/2$ , is trivial. Therefore, we conclude that  $\mathbb{C}P^3/\mathbb{C}P^1$  is stably homotopy equivalent to  $S^{6\mathbb{R}} \vee S^{4\mathbb{R}}$ . This implies

$$\{S^{2\mathbb{R}} \wedge (\mathbb{C}P^3/\mathbb{C}P^1), S^{6\mathbb{R}}\}^{\{e\}} = \pi_2 \oplus \pi_0 = \mathbb{Z}/2 \oplus \mathbb{Z}.$$

The projection to the  $\pi_0$ –summand can be alternatively defined as the mapping degree on  $H^6(*; \mathbb{Z})$ , so it is exactly the characteristic homomorphism  $t$ . We have shown that  $t$  is surjective with kernel  $\mathbb{Z}/2$ . By Corollary 2.9, we have  $t(c_j(\alpha)) = t(\alpha)$  for any  $\alpha \in \{S^{\mathbb{R}+2\mathbb{H}}, S^{6\mathbb{R}}\}S^1$ . So  $c_j$  must send  $\ker t$  to  $\ker t$ . Since  $\ker t \cong \mathbb{Z}/2$ ,  $c_j$  must act trivially on it. □

**Proposition 3.2** *Let  $\alpha$  be an element in  $\{S^{\mathbb{R}+2\mathbb{H}}, S^{6\mathbb{R}}\}^G$  that satisfies the conditions*

$$t(\text{Res}_{S^1}^G(\alpha)) = 0 \quad \text{and} \quad \alpha \cdot e_{\mathbb{R}} = 0.$$

*Then  $\text{Res}_{S^1}^G(\alpha) = 0$ .*

**Proof** By Lemma 2.6, we see that  $\alpha = \text{Tr}_{S^1}^G(\beta)$  for some  $\beta \in \{S^{\mathbb{R}+2\mathbb{H}}, S^{6\mathbb{R}}\}S^1$ . Therefore, by the double coset formula (10),  $\text{Res}_{S^1}^G(\alpha) = \beta + c_j(\beta)$ . By Corollary 2.9,

$$0 = t(\beta + c_j(\beta)) = 2t(\beta).$$

So  $\beta$  is in the kernel of  $t$ , which is  $\mathbb{Z}/2$  by Lemma 3.1. By Lemma 3.1 again,  $c_j(\beta) = \beta$ . So  $\text{Res}_{S^1}^G(\alpha) = 2\beta = 0$ . □

### 3.2 Proof of Theorem 1.2

Let  $X_1$  be the  $K3$  surface and  $X_0 = S^2 \times S^2$ . Let  $\mathfrak{s}_i$  be the unique spin structure on  $X_i$  for  $i = 0, 1$ . We consider the Dehn twist

$$\delta: X_1 \# X_1 \rightarrow X_1 \# X_1$$

along the separating  $S^3$  in the neck. We want to show that  $\delta$  is not smoothly isotopic to the identity map even after a single stabilization. Without loss of generality, we may assume that the stabilization is done in the first copy of  $X_1$ . Then we need to show that the map

$$\delta^s := \text{id}_{X_0} \# \delta : X_0 \# X_1 \# X_1 \rightarrow X_0 \# X_1 \# X_1$$

is not smoothly isotopic to the identity map. As in [26], we will prove this by forming the mapping torus

$$N_{\delta^s} := ((X_0 \# X_1 \# X_1) \times [0, 1]) / (x, 0) \sim (\delta^s(x), 1)$$

and showing that it is a nontrivial smooth bundle over  $S^1$ .

By Lemma 2.23, the product spin structure over the trivial bundle has vanishing  $\text{BF}^G$ . So, it suffices to show that both spin families associated to  $N_{\delta^s}$  have nontrivial  $\text{BF}^G$ .

To prove this, we consider the product family  $(X_i \times S^1, \tilde{s}_i)$  and the twisted family  $(X_i \times S^1, \tilde{s}_i^\tau)$ . By the discussion in [26, beginning of Section 5], the mapping torus  $N_\delta$  can be formed as the fiberwise connected sum

$$(X_1 \times S^1) \#_{\varphi(\tilde{s}_1, \tilde{s}_1^\tau)} (X_1 \times S^1).$$

Therefore, the bundle  $N_{\delta^s}$  can be formed as the fiberwise connected sum

$$(X_0 \times S^1) \#_{\varphi(\tilde{s}_0, \tilde{s}_1)} (X_1 \times S^1) \#_{\varphi(\tilde{s}_1, \tilde{s}_1^\tau)} (X_1 \times S^1)$$

as well as the fiberwise connected sum

$$(X_0 \times S^1) \#_{\varphi(\tilde{s}_0^\tau, \tilde{s}_1^\tau)} (X_1 \times S^1) \#_{\varphi(\tilde{s}_1^\tau, \tilde{s}_1)} (X_1 \times S^1).$$

The two spin families associated to  $N_{\delta^s}$  are

$$(X_0 \times S^1, \tilde{s}_0) \# (X_1 \times S^1, \tilde{s}_1) \# (X_1 \times S^1, \tilde{s}_1^\tau)$$

and

$$(X_0 \times S^1, \tilde{s}_0^\tau) \# (X_1 \times S^1, \tilde{s}_1^\tau) \# (X_1 \times S^1, \tilde{s}_1).$$

We will show that

$$\text{BF}^G((X_0 \times S^1, \tilde{s}_0) \# (X_1 \times S^1, \tilde{s}_1) \# (X_1 \times S^1, \tilde{s}_1^\tau)) \neq 0,$$

and the other family is similar. We use  $\alpha$  to denote the element

$$\text{BF}^G((X_1 \times S^1, \tilde{s}_1) \# (X_1 \times S^1, \tilde{s}_1^\tau)) \in \{S^{\mathbb{R}+2\mathbb{H}}, S^{6\tilde{\mathbb{R}}}\}^G.$$

By Proposition 2.26,  $\text{Res}_{S^1}^G(\alpha)$  can be decomposed as the product of the elements

$$\text{BF}^{S^1}(X_1, \mathfrak{s}_1) \in \{S^{\mathbb{H}}, S^{3\tilde{\mathbb{R}}}\} S^1 \quad \text{and} \quad \text{BF}^{S^1}((X_1 \times S^1, \tilde{\mathfrak{s}}_1^\tau)) \in \{S^{\mathbb{R}+\mathbb{H}}, S^{3\tilde{\mathbb{R}}}\} S^1.$$

By Lemma 2.10, the Seiberg–Witten invariant  $t(\text{Res}_{S^1}^G(\alpha))$  equals 0. (This can also be proved by checking the explicit description of the Seiberg–Witten moduli space given in [26].)

By Corollary 2.27,

$$\text{BF}^G((X_0 \times S^1, \tilde{\mathfrak{s}}_0) \# (X_1 \times S^1, \tilde{\mathfrak{s}}_1) \# (X_1 \times S^1, \tilde{\mathfrak{s}}_1^\tau)) = \alpha \cdot e_{\tilde{\mathbb{R}}}.$$

For the sake of contradiction, suppose  $\alpha \cdot e_{\tilde{\mathbb{R}}} = 0$ . Then, by Proposition 3.2,  $\text{Res}_{S^1}^G(\alpha) = 0$ , which implies

$$\text{BF}^{\{e\}}((X_1 \times S^1, \tilde{\mathfrak{s}}_1) \# (X_1 \times S^1, \tilde{\mathfrak{s}}_1^\tau)) = \text{Res}_{\{e\}}^G(\alpha) = \text{Res}_{\{e\}}^{S^1} \circ \text{Res}_{S^1}^G(\alpha) = 0.$$

However, Kronheimer and Mrowka [26, Proposition 5.1] computed this nonequivariant Bauer–Furuta invariant as  $\eta^3 \neq 0 \in \pi_3$ . (The Kronheimer–Mrowka definition of  $\text{BF}^{\{e\}}$  coincides with ours because of Lemma 2.22.) This is a contradiction and our proof is finished.

## References

- [1] **J F Adams**, *Prerequisites (on equivariant stable homotopy) for Carlsson’s lecture*, from “Algebraic topology” (I Madsen, B Oliver, editors), Lecture Notes in Math. 1051, Springer (1984) 483–532 MR Zbl
- [2] **S Akbulut**, *A fake 4–manifold*, from “Four-manifold theory” (C Gordon, R Kirby, editors), Contemp. Math. 35, Amer. Math. Soc., Providence, RI (1984) 75–141 MR Zbl
- [3] **S Akbulut**, *Isotoping 2–spheres in 4–manifolds*, from “Proceedings of the Gökova Geometry–Topology Conference 2014” (S Akbulut, D Auroux, T Önder, editors), GGT, Gökova (2015) 264–266 MR Zbl
- [4] **S Akbulut, T Mrowka, Y Ruan**, *Torsion classes and a universal constraint on Donaldson invariants for odd manifolds*, Trans. Amer. Math. Soc. 347 (1995) 63–76 MR Zbl
- [5] **D Auckly, H J Kim, P Melvin, D Ruberman**, *Stable isotopy in four dimensions*, J. Lond. Math. Soc. 91 (2015) 439–463 MR Zbl
- [6] **D Auckly, H J Kim, P Melvin, D Ruberman, H Schwartz**, *Isotopy of surfaces in 4–manifolds after a single stabilization*, Adv. Math. 341 (2019) 609–615 MR Zbl

- [7] **D Baraglia**, *Constraints on families of smooth 4-manifolds from Bauer–Furuta invariants*, *Algebr. Geom. Topol.* 21 (2021) 317–349 MR Zbl
- [8] **D Baraglia, H Konno**, *A gluing formula for families Seiberg–Witten invariants*, *Geom. Topol.* 24 (2020) 1381–1456 MR Zbl
- [9] **D Baraglia, H Konno**, *On the Bauer–Furuta and Seiberg–Witten invariants of families of 4-manifolds*, *J. Topol.* 15 (2022) 505–586 MR
- [10] **S Bauer**, *A stable cohomotopy refinement of Seiberg–Witten invariants, II*, *Invent. Math.* 155 (2004) 21–40 MR Zbl
- [11] **S Bauer, M Furuta**, *A stable cohomotopy refinement of Seiberg–Witten invariants, I*, *Invent. Math.* 155 (2004) 1–19 MR Zbl
- [12] **R I Baykur, N Sunukjian**, *Round handles, logarithmic transforms and smooth 4-manifolds*, *J. Topol.* 6 (2013) 49–63 MR Zbl
- [13] **S E Cappell, J L Shaneson**, *Some new four-manifolds*, *Ann. of Math.* 104 (1976) 61–72 MR Zbl
- [14] **T tom Dieck**, *Transformation groups and representation theory*, *Lecture Notes in Math.* 766, Springer (1979) MR Zbl
- [15] **T tom Dieck**, *Transformation groups*, *De Gruyter Studies in Math.* 8, de Gruyter, Berlin (1987) MR Zbl
- [16] **S K Donaldson**, *Irrationality and the  $h$ -cobordism conjecture*, *J. Differential Geom.* 26 (1987) 141–168 MR Zbl
- [17] **S K Donaldson**, *The orientation of Yang–Mills moduli spaces and 4-manifold topology*, *J. Differential Geom.* 26 (1987) 397–428 MR Zbl
- [18] **S K Donaldson, P B Kronheimer**, *The geometry of four-manifolds*, *Oxford Univ. Press* (1990) MR Zbl
- [19] **R Fintushel, R J Stern**, *2-Torsion instanton invariants*, *J. Amer. Math. Soc.* 6 (1993) 299–339 MR Zbl
- [20] **M H Freedman**, *The topology of four-dimensional manifolds*, *J. Differential Geom.* 17 (1982) 357–453 MR Zbl
- [21] **M Furuta**, *Monopole equation and the  $\frac{11}{8}$ -conjecture*, *Math. Res. Lett.* 8 (2001) 279–291 MR Zbl
- [22] **R E Gompf**, *Stable diffeomorphism of compact 4-manifolds*, *Topology Appl.* 18 (1984) 115–120 MR Zbl
- [23] **M Kreck**, *Isotopy classes of diffeomorphisms of  $(k-1)$ -connected almost-parallelizable  $2k$ -manifolds*, from “Algebraic topology” (JL Dupont, IH Madsen, editors), *Lecture Notes in Math.* 763, Springer (1979) 643–663 MR Zbl

- [24] **M Kreck**, *Some closed 4-manifolds with exotic differentiable structure*, from “Algebraic topology” (I Madsen, B Oliver, editors), Lecture Notes in Math. 1051, Springer (1984) 246–262 MR Zbl
- [25] **M Kreck**, *Surgery and duality*, Ann. of Math. 149 (1999) 707–754 MR Zbl
- [26] **P B Kronheimer, T S Mrowka**, *Dehn surgery, the fundamental group and  $SU(2)$* , Math. Res. Lett. 11 (2004) 741–754 MR Zbl
- [27] **N H Kuiper**, *The homotopy type of the unitary group of Hilbert space*, Topology 3 (1965) 19–30 MR Zbl
- [28] **L G Lewis, Jr, J P May, M Steinberger, J E McClure**, *Equivariant stable homotopy theory*, Lecture Notes in Math. 1213, Springer (1986) MR Zbl
- [29] **J Lin, A Mukherjee**, *Family Bauer–Furuta invariant, exotic surfaces and Smale conjecture*, preprint (2021) arXiv 2110.09686
- [30] **J P May**, *Equivariant homotopy and cohomology theory*, CBMS Reg. Conf. Ser. Math. 91, Amer. Math. Soc., Providence, RI (1996) MR Zbl
- [31] **B Perron**, *Pseudo-isotopies et isotopies en dimension quatre dans la catégorie topologique*, Topology 25 (1986) 381–397 MR Zbl
- [32] **F Quinn**, *Isotopy of 4-manifolds*, J. Differential Geom. 24 (1986) 343–372 MR Zbl
- [33] **D Ruberman**, *An obstruction to smooth isotopy in dimension 4*, Math. Res. Lett. 5 (1998) 743–758 MR Zbl
- [34] **S Schwede**, *Lectures on equivariant stable homotopy theory*, preprint (2014) Available at <http://www.math.uni-bonn.de/people/schwede/equivariant.pdf>
- [35] **M Szymik**, *Characteristic cohomotopy classes for families of 4-manifolds*, Forum Math. 22 (2010) 509–523 MR Zbl
- [36] **C T C Wall**, *Diffeomorphisms of 4-manifolds*, J. London Math. Soc. 39 (1964) 131–140 MR Zbl
- [37] **C T C Wall**, *On simply-connected 4-manifolds*, J. London Math. Soc. 39 (1964) 141–149 MR Zbl
- [38] **M Xu**, *The Bauer–Furuta invariant and a cohomotopy refined Ruberman invariant*, PhD thesis, Stony Brook University (2004) MR Available at <https://www.proquest.com/docview/305061387>

Yau Mathematical Sciences Center, Tsinghua University  
Beijing, China

linjian5477@mail.tsinghua.edu.cn

Proposed: András I Stipsicz  
Seconded: Tomasz S Mrowka, Gang Tian

Received: 13 December 2020  
Revised: 27 October 2021

# Cellular objects in isotropic motivic categories

FABIO TANANIA

Our main purpose is to describe the category of isotropic cellular spectra over flexible fields. Guided by Gheorghe, Wang and Xu (Acta Math. 226 (2021) 319–407), we show that it is equivalent, as a stable  $\infty$ -category equipped with a  $t$ -structure, to the derived category of left comodules over the dual of the classical topological Steenrod algebra. In order to obtain this result, the category of isotropic cellular modules over the motivic Brown–Peterson spectrum is also studied, and isotropic Adams and Adams–Novikov spectral sequences are developed. As a consequence, we also compute hom sets in the category of isotropic Tate motives between motives of isotropic cellular spectra.

14F42

*A list of symbols can be found on page 2046.*

## 1 Introduction

Isotropic categories are local versions of motivic categories, obtained by, roughly speaking, killing all anisotropic varieties. Although they often have a handier structure than their global versions, they exhibit some key characteristics of both motivic and classical topological phenomena. In [21], Vishik introduced the isotropic triangulated category of motives and computed the isotropic motivic cohomology of the point, which is strongly related to the Milnor subalgebra. By following this lead, we studied in [19] the isotropic stable motivic homotopy category. In particular, we identified the isotropic motivic homotopy groups of the sphere spectrum with the cohomology of the topological Steenrod algebra, ie the  $E_2$ -page of the classical Adams spectral sequence. These results are quite surprising since they show that topological objects naturally arise from isotropic environments, which could lead to a fruitful exchange between topology and isotropic motivic theory.

Motivic categories, constructed by Morel and Voevodsky (see [16; 23]) in order to study algebraic varieties by topological means, are extremely rich categories. Even

over an algebraically closed field they are more complex than the respective topological counterparts. For example, while every object in the classical stable homotopy category is cellular (built up by attaching spheres), not every motivic spectrum is cellular, since many algebrogeometric phenomena come into the picture. In spite of this, it is still interesting to understand the structure of the category of cellular objects in motivic stable homotopy theory. This project was initiated by Dugger and Isaksen in [3] and much attention has been dedicated to it since then. Our work, in particular, is concerned with understanding the structure of the subcategories of cellular objects in isotropic categories, which we believe could shed light on the deep interconnection with topology.

We have already highlighted that motivic categories are particularly challenging to study. For example, one of the difficulties that one does not encounter in classical topology is the presence of an object  $\tau$  that appears in various incarnations throughout motivic homotopy theory, sometimes as an element of the motivic cohomology of the ground field and sometimes as a map in the 2-complete motivic stable homotopy groups of spheres. Hence, the principal task is to first find some substitutes for the original motivic categories and tools which could help in the process of analyzing them. In the case of algebraically closed fields, for example, topological realization is a very helpful tool since it allows us to study the initial motivic category by looking at its deformation  $\tau = 1$ , which happens to be just the classical stable homotopy theory; see Dugger and Isaksen [4]. However, in this process part of the information is lost, so one can try to recover it by studying other deformations, for example  $\tau = 0$ . This was done by Isaksen in [9], Gheorghe in [5] and Gheorghe, Wang and Xu in [6]. More precisely, in [9] the stable motivic homotopy groups of  $C\tau$ , the cofiber of  $\tau$ , are identified with the  $E_2$ -page of the classical Adams–Novikov spectral sequence, while in [5] the motivic spectrum  $C\tau$  is provided with an  $E_\infty$ -ring structure inducing an isomorphism of rings with higher products between  $\pi_{**}(C\tau)$  and the classical Adams–Novikov  $E_2$ -page. A parallel result for isotropic categories was obtained in [19], where the isotropic sphere spectrum  $\mathfrak{X}$  was equipped with an  $E_\infty$ -ring structure inducing an isomorphism of rings with higher products between  $\pi_{**}(\mathfrak{X})$  and the classical Adams  $E_2$ -page. Moreover, in [6] the category of  $C\tau$ -cellular spectra is described, and is proved to be equivalent as a stable  $\infty$ -category equipped with a  $t$ -structure (see Lurie [13]) to the derived category of left  $\mathrm{BP}_*\mathrm{BP}$ -comodules concentrated in even degrees, where  $\mathrm{BP}$  is the Brown–Peterson spectrum and  $\mathrm{BP}_*\mathrm{BP}$  its  $\mathrm{BP}$ -homology.

We intend to follow a similar path for isotropic categories. Recall that a field  $k$  is called flexible if it is a purely transcendental extension of countable infinite degree over



some other field. In our situation it is really essential to work over flexible fields since, as highlighted in [21], these are the ground fields over which the isotropic categories behave particularly well. For example, over algebraically closed fields, due to the lack of anisotropic varieties, the isotropic category would be just the same as the original motivic category, so in this case the isotropic localization produces nothing new. We are encouraged by the evident parallel between the computations of  $\pi_{**}(C\tau)$  over complex numbers (see [5; 9]) on the one hand, and of  $\pi_{**}(\mathfrak{X})$  over flexible fields (see [19]) on the other. More precisely, we have been guided by the idea that studying the isotropic stable motivic homotopy category over a flexible field is similar in some sense to studying the stable  $\infty$ -category of  $C\tau$ -cellular spectra in the motivic stable homotopy category over complex numbers. Indeed, they obviously share some common features which is highlighted by our main theorem:

**Theorem 1.1** *Let  $k$  be a flexible field of characteristic different from 2. Then there exists a  $t$ -exact equivalence of stable  $\infty$ -categories*

$$\mathcal{D}^b(\mathcal{A}_* \text{-Comod}_*) \xrightarrow{\cong} \mathfrak{X}\text{-Mod}_{\text{cell}, \mathbb{H}\mathbb{Z}/2}^b,$$

where  $\mathcal{A}_*$  is the classical dual Steenrod algebra and  $\mathfrak{X}\text{-Mod}_{\text{cell}, \mathbb{H}\mathbb{Z}/2}^b$  is the stable  $\infty$ -category of  $\mathbb{H}\mathbb{Z}/2$ -complete  $\mathfrak{X}$ -cellular modules having MBP-homology nontrivial in only finitely many Chow–Novikov degrees (the superscript “b” stands for “bounded”; see Definition 8.4).

As a consequence, we obtain that the category of isotropic cellular spectra is completely algebraic, which makes it easier to study. Moreover, it is deeply related to classical topology, as foreseeable from results in [19; 21].

In order to achieve our main results, we need several tools. In particular, it is necessary to develop and study isotropic versions of both the Adams spectral sequence and the Adams–Novikov spectral sequence. This requires a focus on the motivic Brown–Peterson spectrum MBP (see Vezzosi [20]) from an isotropic point of view. In particular, we note that the isotropic Brown–Peterson spectrum is an  $E_\infty$ -ring spectrum, in contrast to the topological picture where BP has been shown not to admit an  $E_\infty$ -ring structure by Lawson in [11]. Then we use techniques developed by Gheorghe, Wang and Xu in [6], based on Lurie’s results (see [13]), to first describe in algebraic terms the category of isotropic MBP-cellular modules, and then the category of all isotropic cellular spectra. Finally, we are also able to provide some results about the cellular subcategory of the isotropic triangulated category of motives, ie the category of isotropic Tate motives.

**Outline** We now briefly present the contents of each section. In Section 2, we provide our main notation. Then we move on to Section 3 by recalling isotropic categories and their main properties, mostly referring to results in [19; 21]. Since we are mainly interested in cellular objects, we recall in Section 4 definitions and some of the main results from [3], which are useful in the rest of the paper. Section 5 is devoted to a deep analysis of the isotropic motivic Adams spectral sequence, which was already initiated in [19]. These results are used in Section 6 to study the motivic Brown–Peterson spectrum from an isotropic perspective. In particular, we compute its isotropic stable homotopy groups. Sections 7 and 8 are modeled on Sections 3, 4 and 5 of [6]. More precisely, in Section 7 we endow the isotropic motivic Brown–Peterson spectrum with an  $E_\infty$ –ring structure, and then identify, as a triangulated category, the category of isotropic MBP–cellular spectra with the category of bigraded  $\mathbb{F}_2$ –vector spaces. In Section 8, after developing an isotropic Adams–Novikov spectral sequence, we describe the category of isotropic cellular spectra in algebraic terms as the derived category of comodules over the dual of the Steenrod algebra equipped with a  $t$ –structure. Finally, in Section 9, we provide an algebraic description of the hom sets in the category of isotropic motives between motives of isotropic cellular spectra, which is a step forward in understanding the category of isotropic Tate motives.

**Acknowledgements** I would like to thank Alexander Vishik for very helpful comments and Dan Isaksen for having pointed out to me the work by Gheorghie, Wang and Xu on which this paper is modeled. I am extremely grateful to Tom Bachmann for very useful remarks. I also wish to thank the referees for very useful comments which helped to improve the exposition and to simplify Section 7.

## 2 Notation

We denote hom sets in  $\mathcal{SH}(k)$  by  $[\cdot, \cdot]$  and the suspension  $\mathbb{S}^{p,q} \wedge X$  of a motivic spectrum  $X$  by  $\Sigma^{p,q} X$ . Moreover, if  $E$  is a motivic  $E_\infty$ –ring spectrum, the stable  $\infty$ –category of  $E$ –modules (see [13]) is denoted by  $E\text{-Mod}$ , its smash product by  $\cdot \wedge_E \cdot$  and hom sets in its homotopy category by  $[\cdot, \cdot]_E$ .

If  $R$  is an algebra and  $C$  a coalgebra, then we denote by  $R\text{-Mod}$  and  $C\text{-Comod}$  the categories of left  $R$ –modules and left  $C$ –comodules, respectively. Hom sets in these categories are both denoted by  $\text{Hom}_R(\cdot, \cdot)$  and  $\text{Hom}_C(\cdot, \cdot)$ , and it will be clear from context if they are meant to be hom of modules or comodules. For a bigraded

object  $M_{**}$  (resp.  $M^{**}$ ) we denote by  $\Sigma^{p,q} M_{**}$  (resp.  $\Sigma^{p,q} M^{**}$ ) its suspension, the bigraded object defined by  $\Sigma^{p,q} M_{a,b} = M_{a-p,b-q}$  (resp.  $\Sigma^{p,q} M^{a,b} = M^{a+p,b+q}$ ). The convention for bigraded homomorphisms between bigraded objects is

$$\text{Hom}^{p,q}(M_{**}, N_{**}) = \text{Hom}^{0,0}(\Sigma^{p,q} M_{**}, N_{**})$$

and

$$\text{Hom}^{p,q}(M^{**}, N^{**}) = \text{Hom}^{0,0}(\Sigma^{p,q} M^{**}, N^{**}),$$

where  $\text{Hom}^{0,0}(\cdot, \cdot)$  denotes the bidegree-preserving homomorphisms. Moreover, the bounded derived categories of  $R\text{-Mod}$  and  $C\text{-Comod}$  are denoted by  $\mathcal{D}^b(R\text{-Mod})$  and  $\mathcal{D}^b(C\text{-Comod})$ , respectively.

### 3 Isotropic motivic categories

In this section we want to introduce the main categories we consider, namely isotropic motivic categories. These categories are built from the respective motivic ones by killing all anisotropic varieties. We refer to [19, Section 2; 21, Section 2] for more details on the construction and properties of isotropic categories.

Let us recall first the definition of flexible field from [21]:

**Definition 3.1** A field  $k$  is called flexible if it is a purely transcendental extension of countable infinite degree:  $k = k_0(t_1, t_2, \dots)$  for some other field  $k_0$ .

Henceforth we assume  $k$  is a flexible base field of characteristic different from 2. We proceed by recalling the definition of a fundamental object in  $\mathcal{SH}(k)$  for the construction of the isotropic stable motivic homotopy category  $\mathcal{SH}(k/k)$ .

**Definition 3.2** Denote by  $Q$  the disjoint union of all connected anisotropic (mod 2) varieties over  $k$ , ie varieties which do not have closed points of odd degree, and by  $\check{C}(Q)$  its Čech simplicial scheme  $\check{C}(Q)_n = Q^{n+1}$  with face and degeneracy maps given by partial projections and partial diagonals, respectively. We define the isotropic sphere spectrum  $\mathfrak{X}$  as  $\text{Cone}(\Sigma_+^\infty \check{C}(Q) \rightarrow S)$  in  $\mathcal{SH}(k)$ .

We recall from [19, Section 2] that  $\mathfrak{X}$  is an idempotent monoid, that is, there is an equivalence  $\mathfrak{X} \wedge \mathfrak{X} \cong \mathfrak{X}$  induced by the map  $S \rightarrow \mathfrak{X}$ , and so it is an  $E_\infty$ -ring spectrum; see [19, Proposition 6.1].

**Definition 3.3** The full triangulated subcategory  $\mathfrak{X} \wedge \mathcal{SH}(k)$  of  $\mathcal{SH}(k)$  will be called the isotropic stable motivic homotopy category and denoted by  $\mathcal{SH}(k/k)$ .

This triangulated category has very nice properties. In particular it is both localizing and colocalizing; see [19, Section 2]. The very same construction was done first for  $\mathcal{DM}(k)$  by Vishik in [21] by tensoring the triangulated category of motives with the idempotent  $M(\mathfrak{X})$ , where  $M : \mathcal{SH}(k) \rightarrow \mathcal{DM}(k)$  is the motivic functor.

**Definition 3.4** The full triangulated subcategory  $M(\mathfrak{X}) \otimes \mathcal{DM}(k)$  of  $\mathcal{DM}(k)$  will be called the isotropic category of motives and denoted by  $\mathcal{DM}(k/k)$ .

The following result tells us that the isotropic stable motivic homotopy category is nothing but the stable  $\infty$ -category of  $\mathfrak{X}$ -modules:

**Proposition 3.5** *There is an equivalence between the isotropic stable motivic homotopy category  $\mathcal{SH}(k/k)$  and the stable  $\infty$ -category  $\mathfrak{X}\text{-Mod}$  of modules over the motivic  $E_\infty$ -ring spectrum  $\mathfrak{X}$ .*

**Proof** This follows immediately from [13, Proposition 4.8.2.10]. □

**Remark 3.6** Since by construction  $\mathfrak{X}$  kills all anisotropic varieties, it kills in particular nontrivial quadratic extensions. Consider an element  $x$  in  $k$  such that neither  $x$  nor  $-x$  is a square. Then  $\mathfrak{X} \wedge \Sigma_+^\infty \text{Spec}(k(\sqrt{x}))$  and  $\mathfrak{X} \wedge \Sigma_+^\infty \text{Spec}(k(\sqrt{-x}))$  are both zero. This implies that the Euler characteristics of  $\text{Spec}(k(\sqrt{x}))$  and  $\text{Spec}(k(\sqrt{-x}))$ , which are equal to  $\langle 2 \rangle(1 + \langle x \rangle)$  and  $\langle 2 \rangle(1 + \langle -x \rangle)$ , respectively, in  $\pi_{0,0}(\mathbf{S}) \cong \text{GW}(k)$  (see [12, Corollary 11.2; 15, Theorem 6.2.2]), vanish in  $\pi_{0,0}(\mathfrak{X})$ . It follows that  $1 + \langle x \rangle$  and  $1 + \langle -x \rangle$  vanish in  $\pi_{0,0}(\mathfrak{X})$  and so does their sum

$$2 + \langle x \rangle + \langle -x \rangle = 2 + \langle 1 \rangle + \langle -1 \rangle = 3 + \langle -1 \rangle.$$

Hence,  $-3 = \langle -1 \rangle$ , and so  $9 = 1$  (so  $8 = 0$ ) in  $\pi_{0,0}(\mathfrak{X})$ . From all this one deduces that  $\mathfrak{X}$  is 2-power torsion.<sup>1</sup>

We are now ready to define isotropic motivic homotopy groups and isotropic motivic homology and cohomology.

**Definition 3.7** Let  $X$  be a motivic spectrum in  $\mathcal{SH}(k)$ . Then the isotropic stable motivic homotopy groups of  $X$  are defined by

$$\pi_{**}^{\text{iso}}(X) = [\mathbf{S}^{**}, \mathfrak{X} \wedge X] = \pi_{**}(\mathfrak{X} \wedge X).$$

---

<sup>1</sup>I am grateful to Tom Bachmann for this argument.

Recall that motivic cohomology with  $\mathbb{Z}/2$ -coefficients is represented by the motivic Eilenberg–Mac Lane spectrum  $H\mathbb{Z}/2$ . Then we define isotropic motivic cohomology as the cohomology theory represented by the motivic  $E_\infty$ -ring spectrum  $\mathfrak{X} \wedge H\mathbb{Z}/2$ .

**Definition 3.8** For any  $X$  in  $S\mathcal{H}(k)$ , we define the isotropic motivic cohomology of  $X$  as

$$H_{\text{iso}}^{**}(X) = [X, \Sigma^{**}(\mathfrak{X} \wedge H\mathbb{Z}/2)]$$

and the isotropic motivic homology of  $X$  as

$$H_{**}^{\text{iso}}(X) = [S^{**}, \mathfrak{X} \wedge H\mathbb{Z}/2 \wedge X] = H_{**}(\mathfrak{X} \wedge X).$$

The isotropic motivic cohomology of the point was computed by Vishik:

**Theorem 3.9** [21, Theorem 3.7] *Let  $k$  be a flexible field. Then for any  $i \geq 0$  there exists a unique cohomology class  $r_i$  of bidegree  $(-2^i + 1)[-2^{i+1} + 1]$  such that*

$$H^{**}(k/k) \cong \Lambda_{\mathbb{F}_2}(r_i)_{i \geq 0}$$

and  $Q_j r_i = \delta_{ij}$ , where the  $Q_j$  are the Milnor operations.

At this point, we want to introduce the isotropic motivic Steenrod algebra  $\mathcal{A}^{**}(k/k)$  and its dual  $\mathcal{A}_{**}(k/k)$ . They are defined as the isotropic motivic cohomology and homology, respectively, of the motivic Eilenberg–Mac Lane spectrum.

**Definition 3.10** The isotropic motivic Steenrod algebra is defined by

$$\mathcal{A}^{**}(k/k) = H_{\text{iso}}^{**}(H\mathbb{Z}/2) = [H\mathbb{Z}/2, \Sigma^{**}(\mathfrak{X} \wedge H\mathbb{Z}/2)] \cong [\mathfrak{X} \wedge H\mathbb{Z}/2, \Sigma^{**}(\mathfrak{X} \wedge H\mathbb{Z}/2)]$$

and its dual by

$$\mathcal{A}_{**}(k/k) = H_{**}^{\text{iso}}(H\mathbb{Z}/2) = [S^{**}, \mathfrak{X} \wedge H\mathbb{Z}/2 \wedge H\mathbb{Z}/2].$$

The structure of  $\mathcal{A}^{**}(k/k)$  was studied in [19, Section 3]. We summarize the main results:

**Proposition 3.11** [19, Propositions 3.5, 3.6 and 3.7] *Let  $k$  be a flexible field. Then there exists an isomorphism of  $H^{**}(k/k)$ – $\mathcal{M}^{**}$ -bimodules*

$$\mathcal{A}^{**}(k/k) \cong H^{**}(k/k) \otimes_{\mathbb{F}_2} \mathcal{G}^{**} \otimes_{\mathbb{F}_2} \mathcal{M}^{**},$$

where  $\mathcal{M}^{**}$  is the Milnor subalgebra  $\Lambda_{\mathbb{F}_2}(Q_i)_{i \geq 0}$  and  $\mathcal{G}^{**}$  is the bigraded topological Steenrod algebra, ie  $\mathcal{G}^{2n,n} = \mathcal{A}^n$ .

By projecting the motivic Cartan formulas (see [24, Propositions 9.7 and 13.4]) to the isotropic category, one gets a coproduct on  $\mathcal{A}^{**}(k/k)$  given by

$$\Delta(\mathrm{Sq}^{2n}) = \sum_{i+j=n} \mathrm{Sq}^{2i} \otimes \mathrm{Sq}^{2j}, \quad \Delta(Q_i) = Q_i \otimes 1 + 1 \otimes Q_i.$$

This coproduct structures  $\mathcal{A}^{**}(k/k)$  as a coalgebra whose dual is described as an  $H_{**}(k/k)$ -algebra by

$$\mathcal{A}_{**}(k/k) \cong \frac{H_{**}(k/k)[\tau_i, \xi_j]_{i \geq 0, j \geq 1}}{(\tau_i^2)},$$

where  $\tau_i$  is the dual of the Milnor operation  $Q_i$  and  $\xi_j$  is the dual of the motivic cohomology operation  $\mathrm{Sq}^{2^j} \cdots \mathrm{Sq}^2$ . The coproduct in  $\mathcal{A}_{**}(k/k)$  is given by (see [24, Lemma 12.11])

$$\psi(\xi_k) = \sum_{i=0}^k \xi_{k-i}^{2^i} \otimes \xi_i, \quad \psi(\tau_k) = \sum_{i=0}^k \xi_{k-i}^{2^i} \otimes \tau_i + \tau_k \otimes 1.$$

**Remark 3.12** By Proposition 3.11, the projection from  $\mathcal{A}^{**}(k/k)$  to its quotient by the left ideal generated by Milnor operations provides a homomorphism

$$\mathcal{A}^{**}(k/k) \rightarrow H^{**}(k/k) \otimes_{\mathbb{F}_2} \mathcal{G}^{**}.$$

This map induces a left  $\mathcal{A}^{**}(k/k)$ -action on  $H^{**}(k/k) \otimes_{\mathbb{F}_2} \mathcal{G}^{**}$  and, dually, a left  $\mathcal{A}_{**}(k/k)$ -coaction on  $H_{**}(k/k) \otimes_{\mathbb{F}_2} \mathcal{G}_{**}$ , where  $\mathcal{G}_{**}$  is the subalgebra  $\mathbb{F}_2[\xi_1, \xi_2, \dots]$ .

### 4 Cellular motivic spectra

We are mostly interested in cellular objects of isotropic motivic categories. We recall from [3, Remark 7.4] that the category of cellular motivic spectra, which we denote by  $\mathcal{SH}(k)_{\mathrm{cell}}$ , is the localizing subcategory of  $\mathcal{SH}(k)$  generated by the spheres  $\Sigma^{p,q}\mathbb{S}$ . Similarly, the category of Tate motives, which we denote by  $\mathcal{DM}(k)_{\mathrm{Tate}}$ , is the localizing subcategory of  $\mathcal{DM}(k)$  generated by the Tate motives  $T(q)[p]$ . If  $E$  is a motivic  $E_\infty$ -ring spectrum, then we denote by  $E\text{-Mod}_{\mathrm{cell}}$  the stable  $\infty$ -category of  $E$ -cellular modules, meaning the localizing subcategory of  $E\text{-Mod}$  generated by  $\Sigma^{p,q}E$ .

**Definition 4.1** The category of  $\mathfrak{X}$ -cellular modules will be called the category of isotropic cellular motivic spectra, and is denoted by  $\mathcal{SH}(k/k)_{\mathrm{cell}}$ . In the same way, the full localizing subcategory of  $\mathcal{DM}(k/k)$  generated by the objects  $M(\mathfrak{X})(q)[p]$  will be called the category of isotropic Tate motives, and is denoted by  $\mathcal{DM}(k/k)_{\mathrm{Tate}}$ .

A fundamental property of the category of cellular objects is that isomorphisms can be detected by motivic homotopy groups:

**Proposition 4.2** [3, Corollary 7.2 and Section 7.9] *Let  $E$  be a motivic  $E_\infty$ -ring spectrum and  $X \rightarrow Y$  be a map of  $E$ -cellular motivic spectra that induces isomorphisms on  $\pi_{p,q}$  for all  $p$  and  $q$  in  $\mathbb{Z}$ . Then the map is a weak equivalence.*

Another essential advantage of dealing with cellular objects is that they allow the construction of very useful convergent spectral sequences.

**Proposition 4.3** [3, Propositions 7.7 and 7.10] *Let  $E$  be a motivic  $E_\infty$ -ring spectrum and  $N$  a left  $E$ -module. If  $M$  is a right  $E$ -cellular spectrum then there is a strongly convergent spectral sequence*

$$E_{s,t,u}^2 \cong \text{Tor}_{s,t,u}^{\pi_{**}(E)}(\pi_{**}(M), \pi_{**}(N)) \Rightarrow \pi_{s+t,u}(M \wedge_E N).$$

*If  $M$  is a left  $E$ -cellular motivic spectrum then there is a conditionally convergent spectral sequence*

$$E_2^{s,t,u} \cong \text{Ext}_{\pi_{**}(E)}^{s,t,u}(\pi_{**}(M), \pi_{**}(N)) \Rightarrow [\Sigma^{t-s,u} M, N]_E.$$

### 5 The isotropic motivic Adams spectral sequence

In this section we recall the construction of the isotropic motivic Adams spectral sequence; see [19, Section 4]. Moreover, we study the circumstances under which the  $E_2$ -page is expressible in terms of Ext-groups over the isotropic motivic Steenrod algebra.

**Definition 5.1** Let  $Y$  be an isotropic motivic spectrum (an object in  $\mathfrak{X}\text{-Mod}$ ). Then the standard isotropic motivic Adams resolution of  $Y$  consists of the Postnikov system

$$\begin{array}{ccccccc} \cdots & \longrightarrow & \overline{(\mathfrak{X} \wedge \mathbb{H}\mathbb{Z}/2)^{\wedge s}} \wedge Y & \longrightarrow & \cdots & \longrightarrow & \overline{\mathfrak{X} \wedge \mathbb{H}\mathbb{Z}/2} \wedge Y & \longrightarrow & Y \\ & \swarrow [1] & \downarrow & & \swarrow [1] & \downarrow & \swarrow [1] & \downarrow & \\ & \mathfrak{X} \wedge \mathbb{H}\mathbb{Z}/2 \wedge \overline{(\mathfrak{X} \wedge \mathbb{H}\mathbb{Z}/2)^{\wedge s}} \wedge Y & & & \mathfrak{X} \wedge \mathbb{H}\mathbb{Z}/2 \wedge \overline{\mathfrak{X} \wedge \mathbb{H}\mathbb{Z}/2} \wedge Y & & & \mathfrak{X} \wedge \mathbb{H}\mathbb{Z}/2 \wedge Y & \end{array}$$

where  $\overline{\mathfrak{X} \wedge \mathbb{H}\mathbb{Z}/2}$  is defined by the exact triangle in  $\mathcal{SH}(k)$

$$\overline{\mathfrak{X} \wedge \mathbb{H}\mathbb{Z}/2} \rightarrow \mathbb{S} \rightarrow \mathfrak{X} \wedge \mathbb{H}\mathbb{Z}/2 \rightarrow \Sigma^{1,0} \overline{\mathfrak{X} \wedge \mathbb{H}\mathbb{Z}/2}.$$

By applying motivic homotopy groups functors  $\pi_{**}$  to the previous Postnikov system we get an unrolled exact couple, which induces in turn a spectral sequence with  $E_1$ -page described by

$$E_1^{s,t,u} \cong \pi_{t-s,u}(\mathfrak{X} \wedge \mathbb{H}\mathbb{Z}/2 \wedge \overline{(\mathfrak{X} \wedge \mathbb{H}\mathbb{Z}/2)})^{\wedge s} \wedge Y$$

and first differential

$$\begin{aligned} d_1^{s,t,u} : \pi_{t-s,u}(\mathfrak{X} \wedge \mathbb{H}\mathbb{Z}/2 \wedge \overline{(\mathfrak{X} \wedge \mathbb{H}\mathbb{Z}/2)})^{\wedge s} \wedge Y \\ \rightarrow \pi_{t-s-1,u}(\mathfrak{X} \wedge \mathbb{H}\mathbb{Z}/2 \wedge \overline{(\mathfrak{X} \wedge \mathbb{H}\mathbb{Z}/2)})^{\wedge s+1} \wedge Y. \end{aligned}$$

In general, differentials on the  $E_r$ -page have tridegrees given by

$$d_r^{s,t,u} : E_r^{s,t,u} \rightarrow E_r^{s+r,t+r-1,u}.$$

We call this spectral sequence the isotropic motivic Adams spectral sequence.

The isotropic Adams spectral sequence converges to the homotopy groups of a motivic spectrum closely related to  $Y$ , namely its  $\mathfrak{X} \wedge \mathbb{H}\mathbb{Z}/2$ -nilpotent completion, which we denote by  $Y_{\mathfrak{X} \wedge \mathbb{H}\mathbb{Z}/2}^{\wedge}$ . Before proceeding, let us recall from [2, Section 5] how to construct the  $E$ -nilpotent completion of a spectrum  $Y$  for a homotopy ring spectrum  $E$ .

**Definition 5.2** Let  $E$  be a homotopy ring spectrum and  $Y$  a motivic spectrum in  $\mathcal{SH}(k)$ . First, define  $\bar{E}$  by the distinguished triangle in  $\mathcal{SH}(k)$

$$\bar{E} \rightarrow S \rightarrow E \rightarrow \Sigma^{1,0}\bar{E}.$$

Then define  $\bar{E}_n$  as  $\text{Cone}(\bar{E}^{\wedge n+1} \rightarrow S)$  in  $\mathcal{SH}(k)$ . This way one gets an inverse system

$$\dots \rightarrow \bar{E}_n \wedge Y \rightarrow \dots \rightarrow \bar{E}_1 \wedge Y \rightarrow \bar{E}_0 \wedge Y,$$

and the  $E$ -nilpotent completion of  $Y$  is the motivic spectrum  $Y_E^{\wedge} = \text{holim}(\bar{E}_n \wedge Y)$ .

Note that, by [19, Proposition 2.3], if  $Y$  is an isotropic motivic spectrum so is  $Y_E^{\wedge}$ .

**Proposition 5.3** Let  $Y$  be an isotropic motivic spectrum. If  $\varprojlim_r^1 E_r^{s,t,u} = 0$  for any  $s, t$  and  $u$ , then the isotropic motivic Adams spectral sequence for  $Y$  is strongly convergent to the stable motivic homotopy groups of the  $\mathbb{H}\mathbb{Z}/2$ -nilpotent completion of  $Y$ .

**Proof** By [2, Proposition 6.3; 4, Remark 6.11], under the vanishing hypothesis on  $\varprojlim_r^1 E_r^{s,t,u}$ , the isotropic motivic Adams spectral sequence strongly converges to  $\pi_{**}(Y_{\mathfrak{X} \wedge \mathbb{H}\mathbb{Z}/2}^{\wedge})$ . It only remains to notice that, since  $Y$  is an  $\mathfrak{X}$ -module, its  $\mathbb{H}\mathbb{Z}/2$ -nilpotent and  $\mathfrak{X} \wedge \mathbb{H}\mathbb{Z}/2$ -nilpotent completions coincide. In fact, after smashing the



morphism of distinguished triangles

$$\begin{array}{ccccccc}
 \overline{\mathbb{H}\mathbb{Z}/2} & \longrightarrow & \mathbb{S} & \longrightarrow & \mathbb{H}\mathbb{Z}/2 & \longrightarrow & \Sigma^{1,0}\overline{\mathbb{H}\mathbb{Z}/2} \\
 \downarrow & & \parallel & & \downarrow & & \downarrow \\
 \overline{\mathfrak{X} \wedge \mathbb{H}\mathbb{Z}/2} & \longrightarrow & \mathbb{S} & \longrightarrow & \mathfrak{X} \wedge \mathbb{H}\mathbb{Z}/2 & \longrightarrow & \Sigma^{1,0}\overline{\mathfrak{X} \wedge \mathbb{H}\mathbb{Z}/2}
 \end{array}$$

with  $\mathfrak{X}$ , one gets

$$\begin{array}{ccccccc}
 \mathfrak{X} \wedge \overline{\mathbb{H}\mathbb{Z}/2} & \longrightarrow & \mathfrak{X} & \longrightarrow & \mathfrak{X} \wedge \mathbb{H}\mathbb{Z}/2 & \longrightarrow & \Sigma^{1,0}\mathfrak{X} \wedge \overline{\mathbb{H}\mathbb{Z}/2} \\
 \downarrow & & \parallel & & \downarrow \cong & & \downarrow \\
 \mathfrak{X} \wedge \overline{\mathfrak{X} \wedge \mathbb{H}\mathbb{Z}/2} & \longrightarrow & \mathfrak{X} & \longrightarrow & \mathfrak{X} \wedge \mathfrak{X} \wedge \mathbb{H}\mathbb{Z}/2 & \longrightarrow & \Sigma^{1,0}\mathfrak{X} \wedge \overline{\mathfrak{X} \wedge \mathbb{H}\mathbb{Z}/2}
 \end{array}$$

since  $\mathfrak{X}$  is an idempotent in  $\mathcal{SH}(k)$ . It follows that  $\mathfrak{X} \wedge \overline{\mathbb{H}\mathbb{Z}/2} \cong \mathfrak{X} \wedge \overline{\mathfrak{X} \wedge \mathbb{H}\mathbb{Z}/2}$ , and so  $\mathfrak{X} \wedge \overline{\mathbb{H}\mathbb{Z}/2}_n \cong \mathfrak{X} \wedge (\overline{\mathfrak{X} \wedge \mathbb{H}\mathbb{Z}/2})_n$  for any  $n$ . Therefore, since  $Y \cong \mathfrak{X} \wedge Y$ ,

$$\begin{aligned}
 Y_{\mathfrak{X} \wedge \mathbb{H}\mathbb{Z}/2}^\wedge &= \text{holim}((\overline{\mathfrak{X} \wedge \mathbb{H}\mathbb{Z}/2})_n \wedge Y) \cong \text{holim}(\mathfrak{X} \wedge (\overline{\mathfrak{X} \wedge \mathbb{H}\mathbb{Z}/2})_n \wedge Y) \\
 &\cong \text{holim}(\mathfrak{X} \wedge \overline{\mathbb{H}\mathbb{Z}/2}_n \wedge Y) \cong \text{holim}(\overline{\mathbb{H}\mathbb{Z}/2}_n \wedge Y) = Y_{\mathbb{H}\mathbb{Z}/2}^\wedge. \quad \square
 \end{aligned}$$

**Remark 5.4** By [14, Section 5.2 and Theorem 1.0.3], the  $\mathbb{H}\mathbb{Z}/2$ -completion of a connective motivic spectrum coincides with its  $(2, \eta)$ -completion. Since all isotropic motivic spectra are 2-power torsion (see Remark 3.6) and so 2-complete, the previous result establishes the convergence of the isotropic Adams spectral sequence for a connective isotropic spectrum to the motivic stable homotopy groups of its  $\eta$ -completion.

**Definition 5.5** A spectral sequence  $\{E_r^{s,t,u}\}$  is called Mittag-Leffler if for each  $s, t$  and  $u$  there exists  $r_0$  such that  $E_r^{s,t,u} \cong E_\infty^{s,t,u}$  whenever  $r > r_0$ .

Note that every Mittag-Leffler spectral sequence satisfies the condition  $\varprojlim_r^1 E_r^{s,t,u} = 0$  for any  $s, t$  and  $u$ ; see [2, after Proposition 6.3]. We will see that in many important cases the isotropic Adams spectral sequence is Mittag-Leffler, which guarantees strong convergence.

Now, we would like to understand what conditions we need to impose on  $Y$  in order to be able to express the  $E_2$ -page of the isotropic Adams spectral sequence in terms of Ext-groups over the isotropic motivic Steenrod algebra. In order to do so, we need the following lemmas.

**Lemma 5.6** Let  $k$  be a flexible field and  $Y$  an object in  $\mathfrak{X}\text{-Mod}$ . Then there exists an isomorphism of left  $H_{**}(k/k)$ -modules

$$H_{**}^{\text{iso}}(\mathfrak{X} \wedge \mathbb{H}\mathbb{Z}/2 \wedge Y) \cong \mathcal{A}_{**}(k/k) \otimes_{H_{**}(k/k)} H_{**}^{\text{iso}}(Y).$$

**Proof** Since by [8, Theorem 5.10]  $\mathbb{H}\mathbb{Z}/2 \wedge \mathbb{H}\mathbb{Z}/2$  is a split  $\mathbb{H}\mathbb{Z}/2$ -module, ie it is equivalent to a wedge sum of the form  $\bigvee_{\alpha \in A} \Sigma^{p_\alpha, q_\alpha} \mathbb{H}\mathbb{Z}/2$ ,

$$\begin{aligned} \mathcal{A}_{**}(k/k) &\cong \pi_{**}(\mathfrak{X} \wedge \mathbb{H}\mathbb{Z}/2 \wedge \mathbb{H}\mathbb{Z}/2) \cong \pi_{**}\left(\bigvee_{\alpha \in A} \Sigma^{p_\alpha, q_\alpha} (\mathfrak{X} \wedge \mathbb{H}\mathbb{Z}/2)\right) \\ &\cong \bigoplus_{\alpha \in A} \Sigma^{p_\alpha, q_\alpha} \pi_{**}(\mathfrak{X} \wedge \mathbb{H}\mathbb{Z}/2) \cong \bigoplus_{\alpha \in A} \Sigma^{p_\alpha, q_\alpha} H_{**}(k/k). \end{aligned}$$

Now, let  $Y$  be any object in  $\mathfrak{X}\text{-Mod}$ . Then

$$\begin{aligned} H_{**}^{\text{iso}}(\mathfrak{X} \wedge \mathbb{H}\mathbb{Z}/2 \wedge Y) &\cong \pi_{**}(\mathfrak{X} \wedge \mathbb{H}\mathbb{Z}/2 \wedge \mathbb{H}\mathbb{Z}/2 \wedge Y) \\ &\cong \pi_{**}\left(\bigvee_{\alpha \in A} \Sigma^{p_\alpha, q_\alpha} (\mathfrak{X} \wedge \mathbb{H}\mathbb{Z}/2 \wedge Y)\right) \\ &\cong \bigoplus_{\alpha \in A} \Sigma^{p_\alpha, q_\alpha} \pi_{**}(\mathfrak{X} \wedge \mathbb{H}\mathbb{Z}/2 \wedge Y) \\ &\cong \bigoplus_{\alpha \in A} \Sigma^{p_\alpha, q_\alpha} H_{**}^{\text{iso}}(Y) \cong \mathcal{A}_{**}(k/k) \otimes_{H_{**}(k/k)} H_{**}^{\text{iso}}(Y). \quad \square \end{aligned}$$

**Remark 5.7** By the previous lemma, the map  $Y \rightarrow \mathfrak{X} \wedge \mathbb{H}\mathbb{Z}/2 \wedge Y$  induces in isotropic motivic homology a coaction  $H_{**}^{\text{iso}}(Y) \rightarrow \mathcal{A}_{**}(k/k) \otimes_{H_{**}(k/k)} H_{**}^{\text{iso}}(Y)$ , which structures  $H_{**}^{\text{iso}}(Y)$  as a left  $\mathcal{A}_{**}(k/k)$ -comodule.

Next we show that, if the homology of an isotropic cellular spectrum  $Y$  is free over  $H_{**}(k/k)$ , then the motivic spectrum  $\mathfrak{X} \wedge \mathbb{H}\mathbb{Z}/2 \wedge Y$  is a split  $\mathfrak{X} \wedge \mathbb{H}\mathbb{Z}/2$ -module.

**Lemma 5.8** *Let  $k$  be a flexible field and  $Y$  an object in  $\mathfrak{X}\text{-Mod}_{\text{cell}}$  such that  $H_{**}^{\text{iso}}(Y)$  is a free left  $H_{**}(k/k)$ -module generated by a set of elements  $\{x_\alpha\}_{\alpha \in A}$ , where  $x_\alpha$  has bidegree  $(q_\alpha)[p_\alpha]$ . Then there exists an isomorphism of spectra*

$$\bigvee_{\alpha \in A} \Sigma^{p_\alpha, q_\alpha} (\mathfrak{X} \wedge \mathbb{H}\mathbb{Z}/2) \xrightarrow{\cong} \mathfrak{X} \wedge \mathbb{H}\mathbb{Z}/2 \wedge Y.$$

**Proof** Since  $H_{**}^{\text{iso}}(Y) \cong \pi_{**}(\mathfrak{X} \wedge \mathbb{H}\mathbb{Z}/2 \wedge Y)$ , we can represent each generator  $x_\alpha$  as a map  $\Sigma^{p_\alpha, q_\alpha} \mathbb{S} \rightarrow \mathfrak{X} \wedge \mathbb{H}\mathbb{Z}/2 \wedge Y$ , where  $(q_\alpha)[p_\alpha]$  is the bidegree of  $x_\alpha$ . For all  $\alpha \in A$ , this map corresponds bijectively to a map  $\Sigma^{p_\alpha, q_\alpha} (\mathfrak{X} \wedge \mathbb{H}\mathbb{Z}/2) \rightarrow \mathfrak{X} \wedge \mathbb{H}\mathbb{Z}/2 \wedge Y$  of  $\mathfrak{X} \wedge \mathbb{H}\mathbb{Z}/2$ -cellular modules. Hence, we get a map

$$\bigvee_{\alpha \in A} \Sigma^{p_\alpha, q_\alpha} (\mathfrak{X} \wedge \mathbb{H}\mathbb{Z}/2) \rightarrow \mathfrak{X} \wedge \mathbb{H}\mathbb{Z}/2 \wedge Y$$

of  $\mathfrak{X} \wedge \mathbb{H}\mathbb{Z}/2$ -cellular modules. In order to check that it is an isomorphism, by Proposition 4.2 it is enough to look at the induced morphisms on homotopy groups.

Indeed, we have, on the one hand,

$$\pi_{**} \left( \bigvee_{\alpha \in A} \Sigma^{p_\alpha, q_\alpha} (\mathfrak{X} \wedge \mathbb{H}\mathbb{Z}/2) \right) \cong \bigoplus_{\alpha \in A} \Sigma^{p_\alpha, q_\alpha} \pi_{**} (\mathfrak{X} \wedge \mathbb{H}\mathbb{Z}/2) \cong \bigoplus_{\alpha \in A} \Sigma^{p_\alpha, q_\alpha} H_{**}(k/k)$$

and, on the other,

$$\pi_{**} (\mathfrak{X} \wedge \mathbb{H}\mathbb{Z}/2 \wedge Y) \cong \bigoplus_{\alpha \in A} H_{**}(k/k) \cdot x_\alpha,$$

by hypothesis. By construction, the map we are considering induces in homotopy groups the homomorphism of  $H_{**}(k/k)$ -modules

$$\pi_{**} \left( \bigvee_{\alpha \in A} \Sigma^{p_\alpha, q_\alpha} (\mathfrak{X} \wedge \mathbb{H}\mathbb{Z}/2) \right) \rightarrow \pi_{**} (\mathfrak{X} \wedge \mathbb{H}\mathbb{Z}/2 \wedge Y)$$

which sends  $1 \in \Sigma^{p_\alpha, q_\alpha} H_{**}(k/k)$  to  $x_\alpha$  for any  $\alpha \in A$ , so it is an isomorphism.  $\square$

The next lemma provides us with a condition under which the isotropic cohomology of a spectrum is dual to its isotropic homology.

**Lemma 5.9** *Let  $k$  be a flexible field and  $Y$  an object in  $\mathfrak{X}\text{-Mod}$  such that there is an isomorphism  $\mathfrak{X} \wedge \mathbb{H}\mathbb{Z}/2 \wedge Y \cong \bigvee_{\alpha \in A} \Sigma^{p_\alpha, q_\alpha} (\mathfrak{X} \wedge \mathbb{H}\mathbb{Z}/2)$  for some set  $A$ . Then for any bidegree  $(q)[p]$  there is an isomorphism*

$$H_{\text{iso}}^{p, q}(Y) \cong \text{Hom}_{H_{**}(k/k)}^{-p, -q} (H_{**}^{\text{iso}}(Y), H_{**}(k/k)).$$

**Proof** Since  $\mathfrak{X} \wedge \mathbb{H}\mathbb{Z}/2 \wedge Y \cong \bigvee_{\alpha \in A} \Sigma^{p_\alpha, q_\alpha} (\mathfrak{X} \wedge \mathbb{H}\mathbb{Z}/2)$  by hypothesis,

$$\begin{aligned} H_{**}^{\text{iso}}(Y) &= [S^{**}, \mathfrak{X} \wedge \mathbb{H}\mathbb{Z}/2 \wedge Y] \cong \left[ S^{**}, \bigvee_{\alpha \in A} \Sigma^{p_\alpha, q_\alpha} (\mathfrak{X} \wedge \mathbb{H}\mathbb{Z}/2) \right] \\ &\cong \bigoplus_{\alpha \in A} \Sigma^{p_\alpha, q_\alpha} H_{**}(k/k), \end{aligned}$$

from which it follows that

$$\text{Hom}_{H_{**}(k/k)}^{-p, -q} (H_{**}^{\text{iso}}(Y), H_{**}(k/k)) \cong \prod_{\alpha \in A} H_{p_\alpha - p, q_\alpha - q}(k/k).$$

On the other hand, we have the chain of isomorphisms

$$\begin{aligned} H_{\text{iso}}^{p, q}(Y) &= [Y, \Sigma^{p, q} (\mathfrak{X} \wedge \mathbb{H}\mathbb{Z}/2)] \cong [\mathfrak{X} \wedge \mathbb{H}\mathbb{Z}/2 \wedge Y, \Sigma^{p, q} (\mathfrak{X} \wedge \mathbb{H}\mathbb{Z}/2)]_{\mathfrak{X} \wedge \mathbb{H}\mathbb{Z}/2} \\ &\cong \left[ \bigvee_{\alpha \in A} \Sigma^{p_\alpha, q_\alpha} (\mathfrak{X} \wedge \mathbb{H}\mathbb{Z}/2), \Sigma^{p, q} (\mathfrak{X} \wedge \mathbb{H}\mathbb{Z}/2) \right]_{\mathfrak{X} \wedge \mathbb{H}\mathbb{Z}/2} \\ &\cong \left[ \bigvee_{\alpha \in A} S^{p_\alpha, q_\alpha}, \Sigma^{p, q} (\mathfrak{X} \wedge \mathbb{H}\mathbb{Z}/2) \right] \cong \prod_{\alpha \in A} H_{p_\alpha - p, q_\alpha - q}(k/k). \quad \square \end{aligned}$$

We now define a certain concept of finiteness which suits the isotropic environment:

**Definition 5.10** A set of bidegrees  $\{(q_\alpha)[p_\alpha]\}_{\alpha \in A}$  is isotropically finite type if, for any bidegree  $(q)[p]$ , there are only finitely many  $\alpha \in A$  such that  $p - p_\alpha \geq 2(q - q_\alpha) \geq 0$ . Moreover, we say that a set of bigraded elements  $\{x_\alpha\}_{\alpha \in A}$  is isotropically finite type if the corresponding set of bidegrees is so.

**Lemma 5.11** Let  $k$  be a flexible field and  $\{(q_\alpha)[p_\alpha]\}_{\alpha \in A}$  an isotropically finite type set of bidegrees. Then for any bidegree  $(q)[p]$ , the obvious map

$$\pi_{p,q} \left( \mathfrak{X} \wedge \bigvee_{\alpha \in A} \Sigma^{p_\alpha, q_\alpha} \mathbb{H}\mathbb{Z}/2 \right) \rightarrow \text{Hom}_{\mathcal{A}^{**}(k/k)}^{p,q} \left( H_{\text{iso}}^{**} \left( \bigvee_{\alpha \in A} \Sigma^{p_\alpha, q_\alpha} \mathbb{H}\mathbb{Z}/2 \right), H^{**}(k/k) \right)$$

is an isomorphism.

**Proof** First note that, for any bidegree  $(q)[p]$ , one has the commutative diagram

$$\begin{array}{ccc} \pi_{p,q} \left( \mathfrak{X} \wedge \bigvee_{\alpha \in A} \Sigma^{p_\alpha, q_\alpha} \mathbb{H}\mathbb{Z}/2 \right) & & \\ \downarrow & \searrow & \\ \text{Hom}_{\mathbb{F}_2}^{p,q} \left( \bigoplus_{\alpha \in A} \Sigma^{-p_\alpha, -q_\alpha} \mathbb{F}_2, H^{**}(k/k) \right) & & \text{Hom}_{\mathcal{A}^{**}(k/k)}^{p,q} \left( H_{\text{iso}}^{**} \left( \bigvee_{\alpha \in A} \Sigma^{p_\alpha, q_\alpha} \mathbb{H}\mathbb{Z}/2 \right), H^{**}(k/k) \right) \\ & \searrow & \downarrow \\ & & \text{Hom}_{\mathcal{A}^{**}(k/k)}^{p,q} \left( \bigoplus_{\alpha \in A} \Sigma^{-p_\alpha, -q_\alpha} \mathcal{A}^{**}(k/k), H^{**}(k/k) \right) \end{array}$$

The left vertical arrow is the isomorphism described by the chain of equivalences

$$\begin{aligned} \pi_{p,q} \left( \mathfrak{X} \wedge \bigvee_{\alpha \in A} \Sigma^{p_\alpha, q_\alpha} \mathbb{H}\mathbb{Z}/2 \right) &\cong \bigoplus_{\alpha \in A} \pi_{p,q} \left( \mathfrak{X} \wedge \Sigma^{p_\alpha, q_\alpha} \mathbb{H}\mathbb{Z}/2 \right) \\ &\cong \bigoplus_{\alpha \in A} H^{p_\alpha - p, q_\alpha - q}(k/k) \cong \prod_{\alpha \in A} H^{p_\alpha - p, q_\alpha - q}(k/k) \\ &\cong \prod_{\alpha \in A} \text{Hom}_{\mathbb{F}_2}^{p,q} \left( \Sigma^{-p_\alpha, -q_\alpha} \mathbb{F}_2, H^{**}(k/k) \right) \\ &\cong \text{Hom}_{\mathbb{F}_2}^{p,q} \left( \bigoplus_{\alpha \in A} \Sigma^{-p_\alpha, -q_\alpha} \mathbb{F}_2, H^{**}(k/k) \right), \end{aligned}$$

where the identification

$$\bigoplus_{\alpha \in A} H^{p_\alpha - p, q_\alpha - q}(k/k) \cong \prod_{\alpha \in A} H^{p_\alpha - p, q_\alpha - q}(k/k)$$

is due to the fact that the set  $\{(q_\alpha)[p_\alpha]\}_{\alpha \in A}$  is isotropically finite type, so for any bidegree  $(q)[p]$  the group  $H^{p_\alpha - p, q_\alpha - q}(k/k)$  is nonzero only for a finite number of  $\alpha \in A$  by Theorem 3.9. The bottom horizontal map is obviously an isomorphism since  $\mathcal{A}^{**}(k/k)$  is an  $\mathbb{F}_2$ -vector space. The right vertical map is an isomorphism since

$$\begin{aligned} \text{Hom}_{\mathcal{A}^{**}(k/k)}^{p,q} \left( H_{\text{iso}}^{**} \left( \bigvee_{\alpha} \Sigma^{p_\alpha, q_\alpha} \mathbb{H}\mathbb{Z}/2 \right), H^{**}(k/k) \right) \\ \cong \text{Hom}_{\mathcal{A}^{**}(k/k)}^{p,q} \left( \prod_{\alpha} H_{\text{iso}}^{**}(\Sigma^{p_\alpha, q_\alpha} \mathbb{H}\mathbb{Z}/2), H^{**}(k/k) \right) \\ = \text{Hom}_{\mathcal{A}^{**}(k/k)}^{p,q} \left( \prod_{\alpha} \Sigma^{-p_\alpha, -q_\alpha} \mathcal{A}^{**}(k/k), H^{**}(k/k) \right) \\ \cong \text{Hom}_{\mathcal{A}^{**}(k/k)}^{p,q} \left( \bigoplus_{\alpha} \Sigma^{-p_\alpha, -q_\alpha} \mathcal{A}^{**}(k/k), H^{**}(k/k) \right), \end{aligned}$$

where the last isomorphism comes from the fact that the set of bidegrees  $\{(q_\alpha)[p_\alpha]\}_{\alpha \in A}$  is isotropically finite type, so for any bidegree  $(q)[p]$  the group

$$\text{Hom}_{\mathcal{A}^{**}(k/k)}^{p,q}(\Sigma^{-p_\alpha, -q_\alpha} \mathcal{A}^{**}(k/k), H^{**}(k/k)) \cong H^{p_\alpha - p, q_\alpha - q}(k/k)$$

is nontrivial only for finitely many  $\alpha \in A$  by Theorem 3.9. □

At this point, we are ready to present the structure of the  $E_2$ -page of the isotropic Adams spectral sequence, which behaves as in the classical case.

**Theorem 5.12** *Let  $k$  be a flexible field and  $Y$  an object in  $\mathfrak{X}\text{-Mod}_{\text{cell}}$  such that  $H_{**}^{\text{iso}}(Y)$  is a free left  $H_{**}(k/k)$ -module generated by an isotropically finite type set of elements  $\{x_\alpha\}_{\alpha \in A}$ . Then the  $E_2$ -page of the isotropic motivic Adams spectral sequence is described by*

$$E_2^{s,t,u} \cong \text{Ext}_{\mathcal{A}^{**}(k/k)}^{s,t,u}(H_{\text{iso}}^{**}(Y), H^{**}(k/k)).$$

**Proof** First, we want to prove by induction that  $H_{**}^{\text{iso}}(\overline{(\mathfrak{X} \wedge \mathbb{H}\mathbb{Z}/2)^{\wedge s}} \wedge Y)$  is a free left  $H_{**}(k/k)$ -module generated by an isotropically finite type set of elements  $\{x_\alpha\}_{\alpha \in A_s}$  for any  $s \geq 0$ . The induction basis is guaranteed by hypothesis after setting  $A_0 = A$ . Suppose the statement is true at the  $s - 1$  stage, ie

$$H_{**}^{\text{iso}}(\overline{(\mathfrak{X} \wedge \mathbb{H}\mathbb{Z}/2)^{\wedge s-1}} \wedge Y) \cong \bigoplus_{\alpha \in A_{s-1}} \Sigma^{1-s,0} H_{**}(k/k) \cdot x_\alpha.$$

Then by Lemma 5.6, the map  $(\overline{\mathfrak{X} \wedge \mathbb{H}\mathbb{Z}/2})^{\wedge s-1} \wedge Y \rightarrow \mathfrak{X} \wedge \mathbb{H}\mathbb{Z}/2 \wedge (\overline{\mathfrak{X} \wedge \mathbb{H}\mathbb{Z}/2})^{\wedge s-1} \wedge Y$  induces in isotropic motivic homology the monomorphism

$$\bigoplus_{\alpha \in A_{s-1}} \Sigma^{1-s,0} H_{**}(k/k) \cdot x_\alpha \rightarrow \bigoplus_{\alpha \in A_{s-1}} \Sigma^{1-s,0} \mathcal{A}_{**}(k/k) \cdot x_\alpha.$$

Hence, the standard Adams resolution induces, for any  $p$  and  $q$ , a short exact sequence

$$0 \rightarrow H_{p,q}^{\text{iso}}((\overline{\mathfrak{X} \wedge \mathbb{H}\mathbb{Z}/2})^{\wedge s-1} \wedge Y) \rightarrow H_{p,q}^{\text{iso}}(\mathfrak{X} \wedge \mathbb{H}\mathbb{Z}/2 \wedge (\overline{\mathfrak{X} \wedge \mathbb{H}\mathbb{Z}/2})^{\wedge s-1} \wedge Y) \rightarrow H_{p-1,q}^{\text{iso}}((\overline{\mathfrak{X} \wedge \mathbb{H}\mathbb{Z}/2})^{\wedge s} \wedge Y) \rightarrow 0.$$

Now note that, by the very structure of the dual of the isotropic motivic Steenrod algebra,  $\mathcal{A}_{**}(k/k)$  is freely generated over  $H_{**}(k/k)$  by a set of generators  $\{1, y_\beta\}_{\beta \in B}$  which is finite in each bidegree and such that  $p_\beta \geq 2q_\beta \geq 0$  for any  $\beta \in B$ , where  $(q_\beta)[p_\beta]$  is the bidegree of  $y_\beta$ . Hence, the set  $\{y_\beta x_\alpha\}_{\beta \in B, \alpha \in A_{s-1}}$  is isotropically finite type and freely generates  $H_{**}^{\text{iso}}((\overline{\mathfrak{X} \wedge \mathbb{H}\mathbb{Z}/2})^{\wedge s} \wedge Y)$  over  $H_{**}(k/k)$ :

$$H_{**}^{\text{iso}}((\overline{\mathfrak{X} \wedge \mathbb{H}\mathbb{Z}/2})^{\wedge s} \wedge Y) \cong \bigoplus_{\beta \in B, \alpha \in A_{s-1}} \Sigma^{-s,0} H_{**}(k/k) \cdot y_\beta x_\alpha.$$

Therefore, Lemma 5.8 implies that all  $\mathfrak{X} \wedge \mathbb{H}\mathbb{Z}/2 \wedge (\overline{\mathfrak{X} \wedge \mathbb{H}\mathbb{Z}/2})^{\wedge s} \wedge Y$  are wedges of appropriately shifted  $\mathfrak{X} \wedge \mathbb{H}\mathbb{Z}/2$ . More precisely, for any  $s \geq 0$ , there exists an isomorphism

$$\mathfrak{X} \wedge \bigvee_{\alpha \in A_s} \Sigma^{p_\alpha - s, q_\alpha} \mathbb{H}\mathbb{Z}/2 \cong \mathfrak{X} \wedge \mathbb{H}\mathbb{Z}/2 \wedge (\overline{\mathfrak{X} \wedge \mathbb{H}\mathbb{Z}/2})^{\wedge s} \wedge Y,$$

where  $A_s = B \times A_{s-1}$ , from which we deduce, using Lemma 5.11, that the  $E_1$ -page of the isotropic Adams spectral sequence can be described by

$$E_1^{s,t,u} \cong \pi_{t-s,u}(\mathfrak{X} \wedge \mathbb{H}\mathbb{Z}/2 \wedge (\overline{\mathfrak{X} \wedge \mathbb{H}\mathbb{Z}/2})^{\wedge s} \wedge Y) \cong \text{Hom}_{\mathcal{A}_{**}(k/k)}^{t,u} \left( \bigoplus_{\alpha \in A_s} \Sigma^{-p_\alpha, -q_\alpha} \mathcal{A}_{**}(k/k), H_{**}(k/k) \right).$$

Moreover, note that

$$0 \leftarrow H_{\text{iso}}^{**}(Y) \leftarrow \bigoplus_{\alpha \in A_0} \Sigma^{-p_\alpha, -q_\alpha} \mathcal{A}_{**}(k/k) \leftarrow \bigoplus_{\alpha \in A_1} \Sigma^{-p_\alpha, -q_\alpha} \mathcal{A}_{**}(k/k) \leftarrow \dots$$

is a free  $\mathcal{A}_{**}(k/k)$ -resolution of  $H_{\text{iso}}^{**}(Y)$ . Thus, for any  $s, t$  and  $u$ , we have an isomorphism

$$E_2^{s,t,u} \cong \text{Ext}_{\mathcal{A}_{**}(k/k)}^{s,t,u}(H_{\text{iso}}^{**}(Y), H_{**}(k/k)). \quad \square$$

By using the isotropic motivic Adams spectral sequence, in [19] we computed the isotropic motivic homotopy groups of the sphere spectrum, which can be identified with the  $E_2$ -page of the classical Adams spectral sequence.

**Theorem 5.13** [19, Theorem 5.7] *Let  $k$  be a flexible field. Then the stable motivic homotopy groups of the  $H\mathbb{Z}/2$ -completed isotropic sphere spectrum are completely described by*

$$\pi_{*,*'}(\mathcal{X}_{H\mathbb{Z}/2}^\wedge) \cong \text{Ext}_{G^{**}}^{2*'-*, 2*', *'}(\mathbb{F}_2, \mathbb{F}_2) \cong \text{Ext}_{A^*}^{2*'-*, *'}(\mathbb{F}_2, \mathbb{F}_2).$$

## 6 The motivic Brown–Peterson spectrum

In this section, we recall from [20] the construction of the motivic Brown–Peterson spectrum. Moreover, we compute its isotropic homology and homotopy, which will be useful later on for the construction of the isotropic motivic Adams–Novikov spectral sequence, and so for the proofs of our main results.

**Definition 6.1** Suppose  $MGL_{(2)}$  is the motivic algebraic cobordism spectrum (see [22, Section 6.3]) localized at 2. Then following [20, Section 5] one defines the motivic Brown–Peterson spectrum at the prime 2 as the colimit of the diagram in  $\mathcal{SH}(k)$

$$\cdots \rightarrow MGL_{(2)} \xrightarrow{e_{(2)}} MGL_{(2)} \xrightarrow{e_{(2)}} MGL_{(2)} \rightarrow \cdots,$$

where  $e_{(2)}$  is the motivic Quillen idempotent.

Note, in particular, that MBP is a homotopy commutative ring spectrum and a direct summand of  $MGL_{(2)}$ .

**Proposition 6.2** *Let  $k$  be a flexible field. Then there is an isomorphism of  $H^{**}(k/k)$ -modules*

$$H_{\text{iso}}^{**}(MGL) \cong H_{\text{iso}}^{**}(BGL) \cong H^{**}(k/k)[c_1, c_2, \dots]$$

and an isomorphism of  $H_{**}(k/k)$ -algebras

$$H_{**}^{\text{iso}}(MGL) \cong H_{**}^{\text{iso}}(BGL) \cong H_{**}(k/k)[b_1, b_2, \dots],$$

where  $c_i$  is the  $i^{\text{th}}$  Chern class in  $H_{\text{iso}}^{2i,i}(BGL)$  and  $b_i \in H_{2i,i}^{\text{iso}}(BGL)$  is the dual of  $c_1^i$  with respect to the monomial basis for any  $i$ .

**Proof** First, note that the maps  $P^1 \rightarrow P^\infty$  and  $\mathfrak{X} \wedge \mathbb{H}\mathbb{Z}/2 \rightarrow \mathfrak{X} \wedge \mathbb{H}\mathbb{Z}/2$  induce a commutative square

$$\begin{CD} H^{**}(P^\infty) @>>> H_{\text{iso}}^{**}(P^\infty) \\ @VVV @VVV \\ H^{**}(P^1) @>>> H_{\text{iso}}^{**}(P^1) \end{CD}$$

where the left vertical morphism is the projection  $H^{**}(k)[c] \rightarrow H^{**}(k)[c]/(c^2)$  and  $c$  is the only nonzero class in  $H^{2,1}(P^\infty) \cong H^{2,1}(P^1) \cong \mathbb{Z}/2$ . If we also denote by  $c$  the images of  $c$  under the horizontal maps in isotropic motivic cohomology, then the right vertical homomorphism is given by the projection

$$H^{**}(k/k)[c] \rightarrow H^{**}(k/k)[c]/(c^2).$$

Hence,  $\mathfrak{X} \wedge \mathbb{H}\mathbb{Z}/2$  is an oriented motivic spectrum (see [20, Definition 3.1]) and the statement follows immediately from [17, Proposition 6.2]. □

Following [8, Section 6], let  $h: L \rightarrow \mathbb{F}_2[b_1, b_2, \dots]$  be the homomorphism from the Lazard ring  $L$  classifying the formal group law on  $\mathbb{F}_2[b_1, b_2, \dots]$  which is isomorphic to the additive one via the exponential  $\sum_{n \geq 0} b_n x^{n+1}$ . Lazard’s theorem implies that  $h(L)$  is a polynomial subring  $\mathbb{F}_2[b'_n \mid n \neq 2^r - 1]$ , where  $b'_n \equiv b_n$  modulo decomposables. Denote by  $\pi: \mathbb{F}_2[b_1, b_2, \dots] \rightarrow h(L)$  a retraction of the inclusion.

In the next proposition, we give a description of isotropic homology and cohomology of the algebraic cobordism spectrum MGL.

**Proposition 6.3** *Let  $k$  be a flexible field. Then the coaction*

$$\Delta: H_{**}^{\text{iso}}(\text{MGL}) \rightarrow \mathcal{A}_{**}(k/k) \otimes_{H_{**}(k/k)} H_{**}^{\text{iso}}(\text{MGL})$$

*factors through  $H_{**}(k/k) \otimes_{\mathbb{F}_2} \mathcal{G}_{**} \otimes_{\mathbb{F}_2} \mathbb{F}_2[b_1, b_2, \dots]$  and the composition*

$$H_{**}^{\text{iso}}(\text{MGL}) \xrightarrow{\Delta} H_{**}(k/k) \otimes_{\mathbb{F}_2} \mathcal{G}_{**} \otimes_{\mathbb{F}_2} \mathbb{F}_2[b_1, b_2, \dots] \xrightarrow{\text{id} \otimes \pi} H_{**}(k/k) \otimes_{\mathbb{F}_2} \mathcal{G}_{**} \otimes_{\mathbb{F}_2} h(L)$$

*is an isomorphism of left  $\mathcal{A}_{**}(k/k)$ -comodule algebras. Dually, the map*

$$H^{**}(k/k) \otimes_{\mathbb{F}_2} \mathcal{G}^{**} \otimes_{\mathbb{F}_2} h(L)^\vee \rightarrow H_{\text{iso}}^{**}(\text{MGL})$$

*is an isomorphism of left  $\mathcal{A}^{**}(k/k)$ -module coalgebras.*



**Proof** From [8, Lemma 5.2], since  $\mathbb{H}\mathbb{Z}/2 \wedge \text{MGL}$  is a split  $\mathbb{H}\mathbb{Z}/2$ -module (see the remark after [8, Definition 5.4]), we deduce that

$$\begin{aligned} H_{**}^{\text{iso}}(\text{MGL}) &\cong \pi_{**}(\mathfrak{X} \wedge \mathbb{H}\mathbb{Z}/2) \otimes_{\pi_{**}(\mathbb{H}\mathbb{Z}/2)} \pi_{**}(\mathbb{H}\mathbb{Z}/2 \wedge \text{MGL}) \\ &\cong H_{**}(k/k) \otimes_{H_{**}(k)} H_{**}(\text{MGL}) \end{aligned}$$

as an  $H_{**}(k/k)$ -algebra. From [8, Theorem 6.5] we know that the coaction

$$\Delta: H_{**}(\text{MGL}) \rightarrow \mathcal{A}_{**}(k) \otimes_{H_{**}(k)} H_{**}(\text{MGL})$$

factors through  $\mathcal{P}_{**} \otimes_{\mathbb{F}_2} \mathbb{F}_2[b_1, b_2, \dots]$  and the composition

$$H_{**}(\text{MGL}) \xrightarrow{\Delta} \mathcal{P}_{**} \otimes_{\mathbb{F}_2} \mathbb{F}_2[b_1, b_2, \dots] \xrightarrow{\text{id} \otimes \pi} \mathcal{P}_{**} \otimes_{\mathbb{F}_2} h(L)$$

is an isomorphism of left  $\mathcal{A}_{**}(k)$ -comodule algebras, where  $\mathcal{P}_{**}$  is the subalgebra of  $\mathcal{A}_{**}(k)$  defined by  $H_{**}(k)[\xi_1, \xi_2, \dots]$ . By tensoring the previous composition with  $H_{**}(k/k)$  over  $H_{**}(k)$  we get the desired isomorphism, which completes the first part. The second part follows easily, since  $\mathcal{G}_{**} \otimes_{\mathbb{F}_2} h(L)$  is isotropically finite type, from Lemmas 5.8 and 5.9 by dualizing the homology isomorphism.  $\square$

The next result provides us with the structure of isotropic homology and cohomology of the motivic Brown–Peterson spectrum MBP.

**Proposition 6.4** *Let  $k$  be a flexible field. Then the isotropic motivic homology of MBP is described as a left  $\mathcal{A}_{**}(k/k)$ -comodule by*

$$H_{**}^{\text{iso}}(\text{MBP}) \cong H_{**}(k/k) \otimes_{\mathbb{F}_2} \mathcal{G}_{**}.$$

*Dually, the isotropic motivic cohomology of MBP is described as a left  $\mathcal{A}^{**}(k/k)$ -module by*

$$H_{\text{iso}}^{**}(\text{MBP}) \cong H^{**}(k/k) \otimes_{\mathbb{F}_2} \mathcal{G}^{**}.$$

**Proof** From [8, Remark 6.20], one knows that MBP is equivalent to  $\text{MGL}_{(2)}/x$ , where  $x$  is any maximal  $h$ -regular sequence (a sequence of homogeneous elements in  $L$  such that  $h(x)$  is a regular sequence in  $h(L)$  which generates the maximal ideal). Therefore, Theorem 6.11 of [8] implies that there exists an isomorphism of  $\mathcal{A}_{**}(k)$ -comodules

$$H_{**}(\text{MBP}) \cong \mathcal{P}_{**}.$$

Since  $\mathbb{H}\mathbb{Z}/2 \wedge \text{MBP}$  is a split  $\mathbb{H}\mathbb{Z}/2$ -module, we deduce from [8, Lemma 5.2] that

$$\begin{aligned} H_{**}^{\text{iso}}(\text{MBP}) &\cong H_{**}(k/k) \otimes_{H_{**}(k)} H_{**}(\text{MBP}) \cong H_{**}(k/k) \otimes_{H_{**}(k)} \mathcal{P}_{**} \\ &\cong H_{**}(k/k) \otimes_{\mathbb{F}_2} \mathcal{G}_{**}, \end{aligned}$$

which proves the first part. The second part follows again from dualization, since  $\mathcal{G}_{**}$  is isotropically finite type, by Lemmas 5.8 and 5.9.  $\square$

Later on, we will also need the isotropic homology and cohomology of  $\text{MBP} \wedge \text{MBP}$ :

**Proposition 6.5** *Let  $k$  be a flexible field. Then the isotropic motivic homology of  $\text{MBP} \wedge \text{MBP}$  is described as a left  $\mathcal{A}_{**}(k/k)$ -comodule by*

$$H_{**}^{\text{iso}}(\text{MBP} \wedge \text{MBP}) \cong H_{**}(k/k) \otimes_{\mathbb{F}_2} \mathcal{G}_{**} \otimes_{\mathbb{F}_2} \mathcal{G}_{**}.$$

*Dually, the isotropic motivic cohomology of  $\text{MBP} \wedge \text{MBP}$  is described as a left  $\mathcal{A}^{**}(k/k)$ -module by*

$$H_{\text{iso}}^{**}(\text{MBP} \wedge \text{MBP}) \cong H^{**}(k/k) \otimes_{\mathbb{F}_2} \mathcal{G}^{**} \otimes_{\mathbb{F}_2} \mathcal{G}^{**}.$$

**Proof** Since  $\text{HZ}/2 \wedge \text{MBP}$  is a split  $\text{HZ}/2$ -module,

$$\begin{aligned} H_{**}^{\text{iso}}(\text{MBP} \wedge \text{MBP}) &\cong (H_{**}(k/k) \otimes_{\mathbb{F}_2} \mathcal{G}_{**}) \otimes_{H_{**}(k/k)} (H_{**}(k/k) \otimes_{\mathbb{F}_2} \mathcal{G}_{**}) \\ &\cong H_{**}(k/k) \otimes_{\mathbb{F}_2} \mathcal{G}_{**} \otimes_{\mathbb{F}_2} \mathcal{G}_{**} \end{aligned}$$

by [8, Lemma 5.2] and Proposition 6.4. The description of the isotropic cohomology follows again by dualizing the homology isomorphism. □

Now, we compute the isotropic stable homotopy groups of  $\text{MBP}$  by using the isotropic Adams spectral sequence developed in the previous section.

**Theorem 6.6** *Let  $k$  be a flexible field. Then the isotropic motivic homotopy groups of  $\text{MBP}$  are described by*

$$\pi_{**}^{\text{iso}}(\text{MBP}) \cong \mathbb{F}_2.$$

**Proof** Note that, by Proposition 6.4,  $H_{**}^{\text{iso}}(\text{MBP})$  is freely generated over  $H_{**}(k/k)$  by  $\mathcal{G}_{**}$ , which is isotropically finite type. Hence, Theorem 5.12 implies that the  $E_2$ -page of the isotropic motivic Adams spectral sequence for  $\mathfrak{X} \wedge \text{MBP}$  is given by

$$E_2^{s,t,u} \cong \text{Ext}_{\mathcal{A}^{**}(k/k)}^{s,t,u}(H_{\text{iso}}^{**}(\text{MBP}), H^{**}(k/k)).$$

Now, we deduce from Proposition 6.4 and [19, Theorem 5.4] that

$$\begin{aligned} \text{Ext}_{\mathcal{A}^{**}(k/k)}^{s,t,u}(H_{\text{iso}}^{**}(\text{MBP}), H^{**}(k/k)) &\cong \text{Ext}_{\mathcal{A}^{**}(k/k)}^{s,t,u}(H^{**}(k/k) \otimes_{\mathbb{F}_2} \mathcal{G}^{**}, H^{**}(k/k)) \\ &\cong \text{Ext}_{\mathcal{G}^{**}}^{s,t,u}(\mathcal{G}^{**}, \mathbb{F}_2) \cong \text{Ext}_{\mathbb{F}_2}^{s,t,u}(\mathbb{F}_2, \mathbb{F}_2) \\ &\cong \begin{cases} \mathbb{F}_2 & \text{if } s = t = u = 0, \\ 0 & \text{otherwise.} \end{cases} \end{aligned}$$

Therefore, the  $E_2$ -page of the isotropic Adams spectral sequence for  $\mathfrak{X} \wedge \text{MBP}$  is concentrated just in the tridegree  $(0, 0, 0)$ , from which it follows that all differentials

from the second on are trivial. Thus, the Mittag-Leffler condition is clearly satisfied, and so strong convergence holds by Proposition 5.3. Then it immediately follows from Remark 5.4 and the fact that MBP is  $\eta$ -complete that

$$\pi_{**}^{\text{iso}}(\text{MBP}) \cong \pi_{**}(\mathfrak{X} \wedge \text{MBP}) \cong \mathbb{F}_2. \quad \square$$

In the following sections it will be also useful to know the isotropic homotopy groups of  $\text{MBP} \wedge \text{MBP}$ , which we compute in the next result.

**Theorem 6.7** *Let  $k$  be a flexible field. Then the isotropic motivic homotopy groups of  $\text{MBP} \wedge \text{MBP}$  are described by*

$$\pi_{**}^{\text{iso}}(\text{MBP} \wedge \text{MBP}) \cong \mathcal{G}_{**}.$$

**Proof** The proof of this theorem goes along the lines of the previous one. Since  $H_{**}^{\text{iso}}(\text{MBP} \wedge \text{MBP}) \cong H_{**}(k/k) \otimes_{\mathbb{F}_2} \mathcal{G}_{**} \otimes_{\mathbb{F}_2} \mathcal{G}_{**}$  by Proposition 6.5 and  $\mathcal{G}_{**} \otimes_{\mathbb{F}_2} \mathcal{G}_{**}$  is isotropically finite type, by Theorem 5.12 the  $E_2$ -page of the isotropic Adams spectral sequence for  $\mathfrak{X} \wedge \text{MBP} \wedge \text{MBP}$  is provided by

$$E_2^{s,t,u} \cong \text{Ext}_{\mathcal{A}^{**}(k/k)}^{s,t,u}(H_{\text{iso}}^{**}(\text{MBP} \wedge \text{MBP}), H^{**}(k/k)).$$

Again, we note that by [19, Theorem 5.4],

$$\begin{aligned} \text{Ext}_{\mathcal{A}^{**}(k/k)}^{s,t,u}(H_{\text{iso}}^{**}(\text{MBP} \wedge \text{MBP}), H^{**}(k/k)) &\cong \text{Ext}_{\mathcal{A}^{**}(k/k)}^{s,t,u}(H^{**}(k/k) \otimes_{\mathbb{F}_2} \mathcal{G}^{**} \otimes_{\mathbb{F}_2} \mathcal{G}^{**}, H^{**}(k/k)) \\ &\cong \text{Ext}_{\mathcal{G}^{**}}^{s,t,u}(\mathcal{G}^{**} \otimes_{\mathbb{F}_2} \mathcal{G}^{**}, \mathbb{F}_2) \cong \text{Ext}_{\mathbb{F}_2}^{s,t,u}(\mathcal{G}^{**}, \mathbb{F}_2) \\ &\cong \begin{cases} \mathcal{G}_{t,u} & \text{if } s = 0, \\ 0 & \text{if } s \neq 0. \end{cases} \end{aligned}$$

In particular, since  $\mathcal{G}_{**}$  is concentrated on the slope 2 line, all differentials from the second on are trivial by degree reasons. Hence, the Mittag-Leffler condition is met, which implies that the spectral sequence is strongly convergent. From all this, it follows as above that

$$\pi_{**}^{\text{iso}}(\text{MBP} \wedge \text{MBP}) \cong \pi_{**}(\mathfrak{X} \wedge \text{MBP} \wedge \text{MBP}) \cong \mathcal{G}_{**}. \quad \square$$

## 7 The category of isotropic cellular MBP-modules

In this section we start by providing  $\mathfrak{X} \wedge \text{MBP}$  with an  $E_\infty$ -ring structure. This allows us to talk about the stable  $\infty$ -category of  $\mathfrak{X} \wedge \text{MBP}$ -modules  $\mathfrak{X} \wedge \text{MBP}\text{-Mod}$  and its

cellular part  $\mathfrak{X} \wedge \text{MBP}\text{-Mod}_{\text{cell}}$ . Our aim is to focus on the category of isotropic cellular MBP-modules, which is the same as that of cellular  $\mathfrak{X} \wedge \text{MBP}$ -modules. In particular, we completely describe the category  $\mathfrak{X} \wedge \text{MBP}\text{-Mod}_{\text{cell}}$  in algebraic terms. This section is structured along the lines of [6, Section 3]. Therefore, before each result we indicate the one from [6] it corresponds to. We hope this will clearly shed light on the deep parallelism between [6] and this work.

**Proposition 7.1** *The homotopy commutative ring structure on  $\mathfrak{X} \wedge \text{MBP}$  extends to an  $E_\infty$ -ring structure.*

**Proof** It follows from [13, Proposition 1.4.4.11] that there exists a  $t$ -structure on  $\mathfrak{X}\text{-Mod}$  with nonnegative part generated by  $\mathfrak{X}^{2n,n}$  for any  $n \in \mathbb{Z}$ . By [1, Theorem A.1],  $\mathfrak{X} \wedge \text{MGL}$  belongs to the nonnegative part of this  $t$ -structure, and so  $\mathfrak{X} \wedge \text{MBP}$  does also. On the other hand, one deduces from Theorem 6.6 and [1, Lemma 2.4] that  $\mathfrak{X} \wedge \text{MBP}$  belongs to the nonpositive part too. Hence,  $\mathfrak{X} \wedge \text{MBP}$  is a homotopy commutative ring spectrum in the heart of the abovementioned  $t$ -structure, which means that it is an  $E_\infty$ -ring spectrum.<sup>2</sup> □

Once we know that  $\mathfrak{X} \wedge \text{MBP}$  is a motivic  $E_\infty$ -ring spectrum, we can consider the stable  $\infty$ -category of  $\mathfrak{X} \wedge \text{MBP}$ -modules and its homotopy category which is tensor triangulated. In particular, we focus on its cellular part.

**Proposition 7.2** *Let  $k$  be a flexible field and  $Y$  an object in  $\mathfrak{X} \wedge \text{MBP}\text{-Mod}_{\text{cell}}$  such that  $\pi_{**}(Y)$  is isomorphic to the  $\mathbb{F}_2$ -vector space  $\bigoplus_{\alpha \in A} \Sigma^{p_\alpha, q_\alpha} \mathbb{F}_2$ . Then there exists an isomorphism of spectra*

$$\bigvee_{\alpha \in A} \Sigma^{p_\alpha, q_\alpha} (\mathfrak{X} \wedge \text{MBP}) \xrightarrow{\cong} Y.$$

**Proof** We follow the lines of the proof of Lemma 5.8. Each generator of  $\pi_{**}(Y)$  represents a map  $\Sigma^{p_\alpha, q_\alpha} \mathbb{S} \rightarrow Y$ . For all  $\alpha \in A$ , this map corresponds bijectively to a map  $\Sigma^{p_\alpha, q_\alpha} (\mathfrak{X} \wedge \text{MBP}) \rightarrow Y$  of  $\mathfrak{X} \wedge \text{MBP}$ -cellular modules. Hence, we get a map

$$\bigvee_{\alpha \in A} \Sigma^{p_\alpha, q_\alpha} (\mathfrak{X} \wedge \text{MBP}) \rightarrow Y$$

of  $\mathfrak{X} \wedge \text{MBP}$ -cellular modules that induces an isomorphism on homotopy groups since  $\pi_{**}(\mathfrak{X} \wedge \text{MBP}) \cong \mathbb{F}_2$  by Theorem 6.6. Therefore, it follows from Proposition 4.2 that the above map is an isomorphism of spectra. □

<sup>2</sup>I am grateful to Tom Bachmann for this argument.

This result implies the following corollary, which corresponds to [6, Corollary 3.3]:

**Corollary 7.3** *Let  $k$  be a flexible field and  $X$  and  $Y$  be objects in  $\mathfrak{X} \wedge \text{MBP-Mod}_{\text{cell}}$ . Then*

$$[X, Y]_{\mathfrak{X} \wedge \text{MBP}} \cong \text{Hom}_{\mathbb{F}_2}^{0,0}(\pi_{**}(X), \pi_{**}(Y)).$$

**Proof** It follows from Proposition 7.2 that

$$X \cong \bigvee_{\alpha \in A} \Sigma^{p_\alpha, q_\alpha} (\mathfrak{X} \wedge \text{MBP}) \quad \text{and} \quad Y \cong \bigvee_{\beta \in B} \Sigma^{p_\beta, q_\beta} (\mathfrak{X} \wedge \text{MBP})$$

for some sets  $A$  and  $B$ . Then

$$\begin{aligned} [X, Y]_{\mathfrak{X} \wedge \text{MBP}} &\cong \left[ \bigvee_{\alpha \in A} \Sigma^{p_\alpha, q_\alpha} S, \bigvee_{\beta \in B} \Sigma^{p_\beta, q_\beta} (\mathfrak{X} \wedge \text{MBP}) \right] \\ &\cong \prod_{\alpha \in A} \bigoplus_{\beta \in B} \pi_{p_\alpha - p_\beta, q_\alpha - q_\beta} (\mathfrak{X} \wedge \text{MBP}) \cong \prod_{\alpha \in A} \bigoplus_{\beta \in B} \Sigma^{p_\alpha - p_\beta, q_\alpha - q_\beta} \mathbb{F}_2 \\ &\cong \text{Hom}_{\mathbb{F}_2}^{0,0} \left( \bigoplus_{\alpha \in A} \Sigma^{p_\alpha, q_\alpha} \mathbb{F}_2, \bigoplus_{\beta \in B} \Sigma^{p_\beta, q_\beta} \mathbb{F}_2 \right) \\ &\cong \text{Hom}_{\mathbb{F}_2}^{0,0} (\pi_{**}(X), \pi_{**}(Y)). \quad \square \end{aligned}$$

The next theorem, which corresponds to [6, Theorem 3.8], identifies  $\mathfrak{X} \wedge \text{MBP-Mod}_{\text{cell}}$  with the category of bigraded  $\mathbb{F}_2$ -vector spaces, which we denote by  $\mathbb{F}_2\text{-Mod}_{**}$ .

**Theorem 7.4** *Let  $k$  be a flexible field. Then the functor*

$$\pi_{**}: \mathfrak{X} \wedge \text{MBP-Mod}_{\text{cell}} \xrightarrow{\cong} \mathbb{F}_2\text{-Mod}_{**}$$

*is an equivalence of categories.*

**Proof** This follows immediately from Proposition 7.2 and Corollary 7.3. □

**Remark 7.5** The equivalence provided by Theorem 7.4 is actually an equivalence of triangulated categories, where  $\mathbb{F}_2\text{-Mod}_{**}$  is structured as a triangulated category in the obvious way. More precisely, the translation functor is the suspension  $\Sigma^{1,0}$  and distinguished triangles are of the form

$$V \xrightarrow{f} W \rightarrow \text{coker}(f) \oplus \Sigma^{1,0} \ker(f) \rightarrow \Sigma^{1,0} V,$$

where  $f$  is a morphism of bigraded  $\mathbb{F}_2$ -vector spaces.

### 8 The category of isotropic cellular spectra

This section is devoted to the understanding of the structure of the category  $\mathfrak{X}\text{-Mod}_{\text{cell}}$ , that is, as we have already noticed, the category of cellular isotropic spectra  $\mathcal{SH}(k/k)_{\text{cell}}$ . We give a nice algebraic description of this category based on the dual of the topological Steenrod algebra. The results here are the isotropic versions of the ones in [6, Sections 4 and 5], therefore the proofs we provide are isotropic adaptations of the respective ones in [6].

In the next lemma, which corresponds to [6, Lemma 5.1], we compute the MBP-homology of isotropic MBP-cellular spectra.

**Lemma 8.1** *Let  $k$  be a flexible field. Then for any  $I \in \mathfrak{X} \wedge \text{MBP-Mod}_{\text{cell}}$  there is an isomorphism of left  $\mathcal{G}_{**}$ -comodules*

$$\text{MBP}_{**}(I) \cong \mathcal{G}_{**} \otimes_{\mathbb{F}_2} \pi_{**}(I).$$

**Proof** Since the motivic spectrum  $I$  is by hypothesis in  $\mathfrak{X} \wedge \text{MBP-Mod}_{\text{cell}}$ , we deduce from Theorem 7.4 that  $I \cong \bigvee_{\alpha \in A} \Sigma^{p_\alpha, q_\alpha} (\mathfrak{X} \wedge \text{MBP})$  for some set  $A$ . Therefore, by Theorem 6.7,

$$\begin{aligned} \text{MBP}_{**}(I) &= \pi_{**}(\text{MBP} \wedge I) \cong \pi_{**} \left( \bigvee_{\alpha \in A} \Sigma^{p_\alpha, q_\alpha} (\mathfrak{X} \wedge \text{MBP} \wedge \text{MBP}) \right) \\ &\cong \bigoplus_{\alpha \in A} \Sigma^{p_\alpha, q_\alpha} \pi_{**}(\mathfrak{X} \wedge \text{MBP} \wedge \text{MBP}) \\ &\cong \bigoplus_{\alpha \in A} \Sigma^{p_\alpha, q_\alpha} \mathcal{G}_{**} \cong \mathcal{G}_{**} \otimes_{\mathbb{F}_2} V, \end{aligned}$$

where  $V \cong \bigoplus_{\alpha \in A} \Sigma^{p_\alpha, q_\alpha} \mathbb{F}_2$ . Now, note that by Theorem 6.6,

$$\pi_{**}(I) \cong \bigoplus_{\alpha \in A} \Sigma^{p_\alpha, q_\alpha} \pi_{**}(\mathfrak{X} \wedge \text{MBP}) \cong V.$$

It follows that

$$\text{MBP}_{**}(I) \cong \mathcal{G}_{**} \otimes_{\mathbb{F}_2} \pi_{**}(I). \quad \square$$

The following lemma, which corresponds to [6, Lemma 5.3], describes algebraically the hom sets from isotropic cellular spectra to isotropic MBP-cellular spectra.

**Lemma 8.2** *Suppose that  $k$  is a flexible field. Then for any  $X \in \mathfrak{X}\text{-Mod}_{\text{cell}}$  and  $I \in \mathfrak{X} \wedge \text{MBP-Mod}_{\text{cell}}$  there is an isomorphism*

$$[X, I] \cong \text{Hom}_{\mathcal{G}_{**}}^{0,0}(\text{MBP}_{**}(X), \text{MBP}_{**}(I)).$$

**Proof** By Theorem 7.4 and Lemma 8.1, we have the sequence of isomorphisms

$$\begin{aligned} [X, I] &\cong [\mathfrak{X} \wedge \text{MBP} \wedge X, I]_{\mathfrak{X} \wedge \text{MBP}} \cong \text{Hom}_{\mathbb{F}_2}^{0,0}(\pi_{**}(\mathfrak{X} \wedge \text{MBP} \wedge X), \pi_{**}(I)) \\ &\cong \text{Hom}_{\mathcal{G}_{**}}^{0,0}(\pi_{**}(\mathfrak{X} \wedge \text{MBP} \wedge X), \mathcal{G}_{**} \otimes_{\mathbb{F}_2} \pi_{**}(I)) \\ &\cong \text{Hom}_{\mathcal{G}_{**}}^{0,0}(\text{MBP}_{**}(X), \text{MBP}_{**}(I)), \end{aligned} \quad \square$$

Before constructing the isotropic version of the Adams–Novikov spectral sequence we need:

**Lemma 8.3** *Let  $k$  be a flexible field and  $Y$  an object in  $\mathfrak{X}\text{-Mod}$ . Then, for any  $s \geq 0$ , there exist isomorphisms*

$$\text{MBP}_{**}((\overline{\mathfrak{X} \wedge \text{MBP}})^{\wedge s} \wedge Y) \cong \Sigma^{-s,0} \overline{\mathcal{G}_{**}}^{\otimes s} \otimes_{\mathbb{F}_2} \text{MBP}_{**}(Y)$$

and

$$\text{MBP}_{**}(\mathfrak{X} \wedge \text{MBP} \wedge (\overline{\mathfrak{X} \wedge \text{MBP}})^{\wedge s} \wedge Y) \cong \Sigma^{-s,0} \mathcal{G}_{**} \otimes_{\mathbb{F}_2} \overline{\mathcal{G}_{**}}^{\otimes s} \otimes_{\mathbb{F}_2} \text{MBP}_{**}(Y).$$

**Proof** First note that, by arguments similar to the ones in Lemma 5.6, we have an isomorphism

$$\text{MBP}_{**}(\mathfrak{X} \wedge \text{MBP} \wedge (\overline{\mathfrak{X} \wedge \text{MBP}})^{\wedge s} \wedge Y) \cong \mathcal{G}_{**} \otimes_{\mathbb{F}_2} \text{MBP}_{**}((\overline{\mathfrak{X} \wedge \text{MBP}})^{\wedge s} \wedge Y)$$

for any isotropic spectrum  $Y$  and any  $s \geq 0$ , so we only need to prove the first part of the statement. We achieve this by an induction argument, after noting that obviously the statement holds for  $s = 0$ .

Now, suppose the statement holds for  $s - 1$ , ie

$$\text{MBP}_{**}((\overline{\mathfrak{X} \wedge \text{MBP}})^{\wedge s-1} \wedge Y) \cong \Sigma^{1-s,0} \overline{\mathcal{G}_{**}}^{\otimes s-1} \otimes_{\mathbb{F}_2} \text{MBP}_{**}(Y)$$

and

$$\text{MBP}_{**}(\mathfrak{X} \wedge \text{MBP} \wedge (\overline{\mathfrak{X} \wedge \text{MBP}})^{\wedge s-1} \wedge Y) \cong \Sigma^{1-s,0} \mathcal{G}_{**} \otimes_{\mathbb{F}_2} \overline{\mathcal{G}_{**}}^{\otimes s-1} \otimes_{\mathbb{F}_2} \text{MBP}_{**}(Y).$$

Then the distinguished triangle in  $\mathcal{SH}(k)$

$$\begin{aligned} (\overline{\mathfrak{X} \wedge \text{MBP}})^{\wedge s} \wedge Y &\rightarrow (\overline{\mathfrak{X} \wedge \text{MBP}})^{\wedge s-1} \wedge Y \rightarrow \mathfrak{X} \wedge \text{MBP} \wedge (\overline{\mathfrak{X} \wedge \text{MBP}})^{\wedge s-1} \wedge Y \\ &\rightarrow \Sigma^{1,0} (\overline{\mathfrak{X} \wedge \text{MBP}})^{\wedge s} \wedge Y \end{aligned}$$

induces in MBP–homology the short exact sequence

$$\begin{aligned} 0 \rightarrow \Sigma^{1-s,0} \overline{\mathcal{G}_{**}}^{\otimes s-1} \otimes_{\mathbb{F}_2} \text{MBP}_{**}(Y) &\rightarrow \Sigma^{1-s,0} \mathcal{G}_{**} \otimes_{\mathbb{F}_2} \overline{\mathcal{G}_{**}}^{\otimes s-1} \otimes_{\mathbb{F}_2} \text{MBP}_{**}(Y) \\ &\rightarrow \Sigma^{1,0} \text{MBP}_{**}((\overline{\mathfrak{X} \wedge \text{MBP}})^{\wedge s} \wedge Y) \rightarrow 0. \end{aligned}$$

It follows that

$$\text{MBP}_{**}((\overline{\mathfrak{X} \wedge \text{MBP}})^{\wedge s} \wedge Y) \cong \Sigma^{-s,0} \overline{\mathcal{G}_{**}}^{\otimes s} \otimes_{\mathbb{F}_2} \text{MBP}_{**}(Y)$$

and

$$\text{MBP}_{**}(\mathfrak{X} \wedge \text{MBP} \wedge (\overline{\mathfrak{X} \wedge \text{MBP}})^{\wedge s} \wedge Y) \cong \Sigma^{-s,0} \mathcal{G}_{**} \otimes_{\mathbb{F}_2} \overline{\mathcal{G}_{**}}^{\otimes s} \otimes_{\mathbb{F}_2} \text{MBP}_{**}(Y). \quad \square$$

We are now ready to construct the isotropic Adams–Novikov spectral sequence, which corresponds to [6, Theorem 5.6]. Before proceeding, we would like to fix some notation.

**Definition 8.4** Let  $X$  be an isotropic spectrum. The Chow–Novikov degree of  $\text{MBP}_{p,q}(X)$  is the integer  $p - 2q$ . We denote by  $\mathfrak{X}\text{-Mod}_{\text{cell}}^b$  the category of bounded isotropic cellular spectra, that is, isotropic cellular spectra whose MBP–homology is nontrivial only for a finite number of Chow–Novikov degrees.

**Theorem 8.5** Let  $k$  be a flexible field and  $X$  and  $Y$  objects in  $\mathfrak{X}\text{-Mod}_{\text{cell}}^b$ . Then there is a strongly convergent spectral sequence

$$E_2^{s,t,u} \cong \text{Ext}_{\mathcal{G}_{**}}^{s,t,u}(\text{MBP}_{**}(X), \text{MBP}_{**}(Y)) \Rightarrow [\Sigma^{t-s,u} X, Y_{\mathbb{H}\mathbb{Z}/2}^{\wedge}].$$

**Proof** Consider the Postnikov system in  $\mathfrak{X}\text{-Mod}_{\text{cell}}$

$$\begin{array}{ccccccc} \cdots & \longrightarrow & (\overline{\mathfrak{X} \wedge \text{MBP}})^{\wedge s} \wedge Y & \longrightarrow & \cdots & \longrightarrow & \overline{\mathfrak{X} \wedge \text{MBP}} \wedge Y & \longrightarrow & Y \\ & \searrow & \downarrow & & \searrow & \downarrow & \swarrow & \downarrow & \downarrow \\ & [1] & \mathfrak{X} \wedge \text{MBP} \wedge (\overline{\mathfrak{X} \wedge \text{MBP}})^{\wedge s} \wedge Y & & [1] & \mathfrak{X} \wedge \text{MBP} \wedge \overline{\mathfrak{X} \wedge \text{MBP}} \wedge Y & [1] & \mathfrak{X} \wedge \text{MBP} \wedge Y & \end{array}$$

where  $\overline{\mathfrak{X} \wedge \text{MBP}}$  is defined by the distinguished triangle in  $\mathcal{SH}(k)$

$$\overline{\mathfrak{X} \wedge \text{MBP}} \rightarrow \mathbb{S} \rightarrow \mathfrak{X} \wedge \text{MBP} \rightarrow \Sigma^{1,0} \overline{\mathfrak{X} \wedge \text{MBP}}.$$

If we apply the functor  $[\Sigma^{**} X, -]$  we get an unrolled exact couple

$$\begin{array}{ccccccc} \cdots & \longrightarrow & [\Sigma^{**} X, \overline{\mathfrak{X} \wedge \text{MBP}} \wedge Y] & \longrightarrow & \cdots & \longrightarrow & [\Sigma^{**} X, Y] \\ & \searrow & \downarrow & \swarrow & \searrow & \downarrow & \downarrow \\ & [1] & [\Sigma^{**} X, \mathfrak{X} \wedge \text{MBP} \wedge \overline{\mathfrak{X} \wedge \text{MBP}} \wedge Y] & & [1] & [\Sigma^{**} X, \mathfrak{X} \wedge \text{MBP} \wedge Y] & \end{array}$$

that induces a spectral sequence with  $E_1$ –page given by

$$E_1^{s,t,u} \cong [\Sigma^{t-s,u} X, \mathfrak{X} \wedge \text{MBP} \wedge (\overline{\mathfrak{X} \wedge \text{MBP}})^{\wedge s} \wedge Y]$$

and first differential

$$d_1^{s,t,u} : E_1^{s,t,u} \rightarrow E_1^{s+1,t,u}.$$



This is what we call the isotropic Adams–Novikov spectral sequence. Note that by Lemmas 8.2 and 8.3 the  $E_1$ –page has a nice description:

$$E_1^{s,t,u} \cong \text{Hom}_{\mathcal{G}_{**}}^{t,u}(\text{MBP}_{**}(X), \mathcal{G}_{**} \otimes_{\mathbb{F}_2} \overline{\mathcal{G}_{**}}^{\otimes s} \otimes_{\mathbb{F}_2} \text{MBP}_{**}(Y)).$$

Hence, the  $E_2$ –page has the usual description given in terms of Ext–groups of left  $\mathcal{G}_{**}$ –comodules:

$$E_2^{s,t,u} \cong \text{Ext}_{\mathcal{G}_{**}}^{s,t,u}(\text{MBP}_{**}(X), \text{MBP}_{**}(Y)).$$

By standard formal reasons, this spectral sequence actually converges to the groups  $[\Sigma^{t-s,u} X, Y_{\mathfrak{X} \wedge \text{MBP}}^\wedge]$ . We only have to notice that

$$Y_{\mathfrak{X} \wedge \text{MBP}}^\wedge \cong Y_{\mathfrak{X} \wedge \text{HZ}/2}^\wedge \cong Y_{\text{HZ}/2}^\wedge.$$

The second isomorphism comes from the same argument as the proof of Proposition 5.3. Regarding the first isomorphism, we may consider, following [4, Section 7.3], the bicompletion  $Y_{\{\mathfrak{X} \wedge \text{MBP}, \mathfrak{X} \wedge \text{HZ}/2\}}^\wedge$ . This spectrum may be obtained by computing the homotopy limit of the cosimplicial spectrum

$$\begin{aligned} (\mathfrak{X} \wedge \text{HZ}/2 \wedge Y)_{\mathfrak{X} \wedge \text{MBP}}^\wedge &\rightrightarrows ((\mathfrak{X} \wedge \text{HZ}/2)^{\wedge 2} \wedge Y)_{\mathfrak{X} \wedge \text{MBP}}^\wedge \\ &\rightrightarrows ((\mathfrak{X} \wedge \text{HZ}/2)^{\wedge 3} \wedge Y)_{\mathfrak{X} \wedge \text{MBP}}^\wedge \rightrightarrows \cdots \end{aligned}$$

or, equivalently, by computing the homotopy limit of the cosimplicial spectrum

$$\begin{aligned} (\mathfrak{X} \wedge \text{MBP} \wedge Y)_{\mathfrak{X} \wedge \text{HZ}/2}^\wedge &\rightrightarrows ((\mathfrak{X} \wedge \text{MBP})^{\wedge 2} \wedge Y)_{\mathfrak{X} \wedge \text{HZ}/2}^\wedge \\ &\rightrightarrows ((\mathfrak{X} \wedge \text{MBP})^{\wedge 3} \wedge Y)_{\mathfrak{X} \wedge \text{HZ}/2}^\wedge \rightrightarrows \cdots \end{aligned}$$

Since  $\text{HZ}/2$  is a motivic MBP–module, for any  $n$ ,

$$((\mathfrak{X} \wedge \text{HZ}/2)^{\wedge n} \wedge Y)_{\mathfrak{X} \wedge \text{MBP}}^\wedge \cong (\mathfrak{X} \wedge \text{HZ}/2)^{\wedge n} \wedge Y,$$

from which it follows that the first homotopy limit is just  $Y_{\mathfrak{X} \wedge \text{HZ}/2}^\wedge$ . On the other hand, we know that  $\mathfrak{X} \wedge \text{MBP}$  is  $\text{HZ}/2$ –complete; thus, for any  $n$ ,

$$((\mathfrak{X} \wedge \text{MBP})^{\wedge n} \wedge Y)_{\mathfrak{X} \wedge \text{HZ}/2}^\wedge \cong (\mathfrak{X} \wedge \text{MBP})^{\wedge n} \wedge Y,$$

and the second homotopy limit gives back  $Y_{\mathfrak{X} \wedge \text{MBP}}^\wedge$ . This implies  $Y_{\mathfrak{X} \wedge \text{MBP}}^\wedge \cong Y_{\mathfrak{X} \wedge \text{HZ}/2}^\wedge$ .

It only remains to prove the strong convergence. The arguments are the same as in [6, Theorem 3.2] and we report them here only for completeness. First, suppose that  $\text{MBP}_{**}(X)$  is concentrated in Chow–Novikov degrees  $[a, b]$  and  $\text{MBP}_{**}(Y)$  is concentrated in Chow–Novikov degrees  $[c, d]$ . Then the  $E_1$ –page, and so all the following pages, are trivial outside the range  $c - b + 2u \leq t \leq d - a + 2u$ . Now, note that the differential on the  $E_r$ –page has, as usual, the tridegree  $(r, r - 1, 0)$ , which

means in particular that it is trivial when  $r - 1 > d - a - c + b$ . This amounts to saying that the spectral sequence collapses at the  $E_{d-a-c+b+2}$ -page, and so it is strongly convergent.  $\square$

**Definition 8.6** Let  $\mathfrak{X}\text{-Mod}_{\text{cell},\mathbb{H}\mathbb{Z}/2}$  be the full triangulated subcategory of  $\mathfrak{X}\text{-Mod}_{\text{cell}}$  consisting of  $\mathbb{H}\mathbb{Z}/2$ -complete cellular isotropic spectra. Denote by  $\mathfrak{X}\text{-Mod}_{\text{cell},\mathbb{H}\mathbb{Z}/2}^{b,\geq 0}$  the full subcategory of  $\mathfrak{X}\text{-Mod}_{\text{cell},\mathbb{H}\mathbb{Z}/2}^b$  whose objects have MBP-homology concentrated in nonnegative Chow–Novikov degrees, and by  $\mathfrak{X}\text{-Mod}_{\text{cell},\mathbb{H}\mathbb{Z}/2}^{b,\leq 0}$  the full subcategory of  $\mathfrak{X}\text{-Mod}_{\text{cell},\mathbb{H}\mathbb{Z}/2}^b$  whose objects have MBP-homology concentrated in nonpositive Chow–Novikov degrees. Finally, let  $\mathfrak{X}\text{-Mod}_{\text{cell},\mathbb{H}\mathbb{Z}/2}^{\heartsuit}$  be the full subcategory whose objects are in  $\mathfrak{X}\text{-Mod}_{\text{cell},\mathbb{H}\mathbb{Z}/2}^{b,\geq 0}$  and  $\mathfrak{X}\text{-Mod}_{\text{cell},\mathbb{H}\mathbb{Z}/2}^{b,\leq 0}$ , ie the objects have MBP-homology concentrated in Chow–Novikov degree 0.

We want to point out that, since  $\mathfrak{X} \wedge \mathbb{H}\mathbb{Z}/2$  is a  $\mathfrak{X} \wedge \text{MBP}$ -module and  $\mathfrak{X} \wedge \text{MBP}$  is  $\mathfrak{X} \wedge \mathbb{H}\mathbb{Z}/2$ -complete, the subcategories of  $\mathbb{H}\mathbb{Z}/2$ -complete and MBP-complete isotropic spectra coincide.

The next corollary, which corresponds to [6, Corollary 4.7], computes hom sets from  $\mathfrak{X}\text{-Mod}_{\text{cell},\mathbb{H}\mathbb{Z}/2}^{b,\geq 0}$  to  $\mathfrak{X}\text{-Mod}_{\text{cell},\mathbb{H}\mathbb{Z}/2}^{b,\leq 0}$  in algebraic terms.

**Corollary 8.7** *Let  $k$  be a flexible field,  $X$  an object in  $\mathfrak{X}\text{-Mod}_{\text{cell},\mathbb{H}\mathbb{Z}/2}^{b,\geq 0}$  and  $Y$  in  $\mathfrak{X}\text{-Mod}_{\text{cell},\mathbb{H}\mathbb{Z}/2}^{b,\leq 0}$ . Then the functor  $\text{MBP}_{**}$  provides an isomorphism*

$$[X, Y] \cong \text{Hom}_{\mathcal{G}_{**}}^{0,0}(\text{MBP}_{**}(X), \text{MBP}_{**}(Y)).$$

**Proof** As we have already pointed out, the  $E_1$ -page of the isotropic Adams–Novikov spectral sequence is given by

$$E_1^{s,t,u} \cong \text{Hom}_{\mathcal{G}_{**}}^{t,u}(\text{MBP}_{**}(X), \mathcal{G}_{**} \otimes_{\mathbb{F}_2} \overline{\mathcal{G}_{**}}^{\otimes s} \otimes_{\mathbb{F}_2} \text{MBP}_{**}(Y)).$$

Since we are interested in the group  $[X, Y]$ , the part of the  $E_1$ -page that is involved consists of the groups in tridegrees  $(t, t, 0)$ . By hypothesis,  $X$  is in  $\mathfrak{X}\text{-Mod}_{\text{cell},\mathbb{H}\mathbb{Z}/2}^{b,\geq 0}$  while  $Y$  is in  $\mathfrak{X}\text{-Mod}_{\text{cell},\mathbb{H}\mathbb{Z}/2}^{b,\leq 0}$ , so, among these groups, only  $E_1^{0,0,0}$  is nontrivial. Since in this tridegree all differentials from the second on are trivial by degree reasons,

$$\begin{aligned} [X, Y] &\cong E_2^{0,0,0} \cong \text{Ext}_{\mathcal{G}_{**}}^{0,0,0}(\text{MBP}_{**}(X), \text{MBP}_{**}(Y)) \\ &\cong \text{Hom}_{\mathcal{G}_{**}}^{0,0}(\text{MBP}_{**}(X), \text{MBP}_{**}(Y)), \end{aligned} \quad \square$$

By using the isotropic Adams–Novikov spectral sequence we also get a corollary, which corresponds to [6, Corollary 4.8] and is a generalization of [19, Theorem 5.7]:

**Corollary 8.8** *Let  $k$  be a flexible field and  $X$  and  $Y$  objects in  $\mathfrak{X}\text{-Mod}_{\text{cell,HZ}/2}^\heartsuit$ . Then there is an isomorphism*

$$[\Sigma^{t,u} X, Y] \cong \text{Ext}_{\mathcal{G}_{**}}^{2u-t,2u,u}(\text{MBP}_{**}(X), \text{MBP}_{**}(Y)).$$

**Proof** This follows because the differentials  $d_r^{s,t,u} : E_r^{s,t,u} \rightarrow E_r^{s+r,t+r-1,u}$  of the isotropic Adams–Novikov spectral sequence are trivial for  $r \geq 2$  since  $E_2^{s,t,u}$  is trivial for  $t \neq 2u$ . Hence, the spectral sequence is strongly convergent and collapses at the second page, from which we get that

$$[\Sigma^{t,u} X, Y] \cong E_2^{2u-t,2u,u} \cong \text{Ext}_{\mathcal{G}_{**}}^{2u-t,2u,u}(\text{MBP}_{**}(X), \text{MBP}_{**}(Y)). \quad \square$$

Before proceeding, we also need the following lemma which essentially corresponds to [6, Lemma 4.10].

**Lemma 8.9** *Let  $k$  be a flexible field and  $M$  a  $\mathcal{G}_{**}$ –comodule concentrated in Chow–Novikov degree 0 which is finitely generated as an  $\mathbb{F}_2$ –vector space. Then there exists an object  $X$  in  $\mathfrak{X}\text{-Mod}_{\text{cell,HZ}/2}^\heartsuit$  such that  $M \cong \text{MBP}_{**}(X)$ .*

**Proof** Since by hypothesis  $M$  is a finite-dimensional  $\mathbb{F}_2$ –vector space, according to [10, Theorem 3.3] one has a finite filtration of subcomodules

$$0 \cong M_0 \subset M_1 \subset \dots \subset M_n \cong M$$

such that, for any  $i$ ,  $M_i/M_{i-1}$  is stably isomorphic to  $\mathbb{F}_2$ , ie  $M_i/M_{i-1} \cong \Sigma^{2q_i,q_i} \mathbb{F}_2$  for some integer  $q_i$ . We want to prove the statement by induction on  $i$ . First, note that by Theorem 6.6 the comodule  $\Sigma^{2q_i,q_i} \mathbb{F}_2$  is the MBP–homology of the isotropic spectrum  $\Sigma^{2q_i,q_i} \mathfrak{X}_{\text{HZ}/2}^\wedge$  for any  $i$ . Now, suppose that there exists an object  $X_{i-1}$  in  $\mathfrak{X}\text{-Mod}_{\text{cell,HZ}/2}^\heartsuit$  such that  $M_{i-1} \cong \text{MBP}_{**}(X_{i-1})$ . Then the short exact sequence

$$0 \rightarrow M_{i-1} \rightarrow M_i \rightarrow \Sigma^{2q_i,q_i} \mathbb{F}_2 \rightarrow 0$$

represents an element of  $\text{Ext}_{\mathcal{G}_{**}}^{1,0,0}(\Sigma^{2q_i,q_i} \mathbb{F}_2, M_{i-1})$ , namely, by Corollary 8.8, a morphism  $f_i$  in  $[\Sigma^{2q_i-1,q_i} \mathfrak{X}_{\text{HZ}/2}^\wedge, X_{i-1}]$ . Let us define  $X_i$  as  $\text{Cone}(f_i)$ . Then we have a long exact sequence in MBP–homology

$$\dots \rightarrow \Sigma^{2q_i-1,q_i} \mathbb{F}_2 \xrightarrow{0} M_{i-1} \rightarrow \text{MBP}_{**}(X_i) \rightarrow \Sigma^{2q_i,q_i} \mathbb{F}_2 \xrightarrow{0} \Sigma^{1,0} M_{i-1} \rightarrow \dots$$

Note that the connecting homomorphism

$$g_{i*} : \text{Ext}^{0,0,0}(\Sigma^{2q_i,q_i} \mathbb{F}_2, \Sigma^{2q_i,q_i} \mathbb{F}_2) \rightarrow \text{Ext}^{1,0,0}(\Sigma^{2q_i,q_i} \mathbb{F}_2, M_{i-1}),$$

described as the Yoneda product with the element  $g_i$  of  $\text{Ext}_{\mathcal{G}_{**}}^{1,0,0}(\Sigma^{2q_i,q_i}\mathbb{F}_2, M_{i-1})$  corresponding to the short exact sequence

$$0 \rightarrow M_{i-1} \rightarrow \text{MBP}_{**}(X_i) \rightarrow \Sigma^{2q_i,q_i}\mathbb{F}_2 \rightarrow 0,$$

converges to the map

$$f_{i*} : [\Sigma^{2q_i-1,q_i}\mathfrak{X}_{\mathbb{H}\mathbb{Z}/2}^\wedge, \Sigma^{2q_i-1,q_i}\mathfrak{X}_{\mathbb{H}\mathbb{Z}/2}^\wedge] \rightarrow [\Sigma^{2q_i-1,q_i}\mathfrak{X}_{\mathbb{H}\mathbb{Z}/2}^\wedge, X_{i-1}]$$

induced by  $f_i$  in isotropic homotopy groups; see [18, Theorem 2.3.4]. By Corollary 8.8 the isotropic Adams–Novikov spectral sequence collapses at the second page, so  $g_{i*} = f_{i*}$ . It follows that the extensions  $g_i$  and  $f_i$  coincide, which implies that  $\text{MBP}_{**}(X_i) \cong M_i$ . □

The next result is the isotropic equivalent of [6, Lemma 4.2].

**Lemma 8.10** *Let  $k$  be a flexible field and  $X_\alpha$  be a filtered system in  $\mathfrak{X}\text{-Mod}_{\text{cell},\mathbb{H}\mathbb{Z}/2}^\heartsuit}$ . Then the colimit  $\text{colim } X_\alpha$  in  $\mathfrak{X}\text{-Mod}_{\text{cell}}$  also belongs to  $\mathfrak{X}\text{-Mod}_{\text{cell},\mathbb{H}\mathbb{Z}/2}^\heartsuit}$ .*

**Proof** First note that, since  $\text{MBP}_{**}(\text{colim } X_\alpha) \cong \text{colim } \text{MBP}_{**}(X_\alpha)$ ,  $\text{colim } X_\alpha$  has MBP–homology concentrated in Chow–Novikov degree 0. Moreover, recall from [18, Corollary A1.2.12] that  $\text{Ext}_{\mathcal{G}_{**}}(\mathbb{F}_2, -)$  may be computed as the homology of the cobar complex for the second variable. Since the cobar complex preserves filtered colimits, so does  $\text{Ext}_{\mathcal{G}_{**}}(\mathbb{F}_2, -)$ . Then Corollary 8.8 implies that

$$\begin{aligned} \pi_{t,u}(\text{colim } X_\alpha) &\cong \text{colim } \pi_{t,u}(X_\alpha) \cong \text{colim } \text{Ext}_{\mathcal{G}_{**}}^{2u-t,2u,u}(\mathbb{F}_2, \text{MBP}_{**}(X_\alpha)) \\ &\cong \text{Ext}_{\mathcal{G}_{**}}^{2u-t,2u,u}(\mathbb{F}_2, \text{colim } \text{MBP}_{**}(X_\alpha)) \\ &\cong \text{Ext}_{\mathcal{G}_{**}}^{2u-t,2u,u}(\mathbb{F}_2, \text{MBP}_{**}(\text{colim } X_\alpha)) \cong \pi_{t,u}((\text{colim } X_\alpha)_{\mathbb{H}\mathbb{Z}/2}^\wedge) \end{aligned}$$

from which it follows that  $\text{colim } X_\alpha$  is  $\mathbb{H}\mathbb{Z}/2$ –complete. □

We are now ready to identify  $\mathfrak{X}\text{-Mod}_{\text{cell},\mathbb{H}\mathbb{Z}/2}^\heartsuit}$  with the abelian category of left  $\mathcal{G}_{**}$ –comodules concentrated in Chow–Novikov degree 0 that we denote by  $\mathcal{G}_{**}\text{-Comod}_{**}^0$ . The following proposition is an isotropic version of [6, Proposition 4.11]:

**Proposition 8.11** *Let  $k$  be a flexible field. Then the functor*

$$\text{MBP}_{**} : \mathfrak{X}\text{-Mod}_{\text{cell},\mathbb{H}\mathbb{Z}/2}^\heartsuit} \xrightarrow{\cong} \mathcal{G}_{**}\text{-Comod}_{**}^0$$

*is an equivalence of categories.*

**Proof** First, note that Corollary 8.7 guarantees that the functor  $\text{MBP}_{**}$  is fully faithful. We just need to show that it is essentially surjective. Recall from [7, Propositions 1.4.10, 1.4.4 and 1.4.1] that any left  $\mathcal{G}_{**}$ -comodule  $M$  is a filtered colimit of comodules  $M_\alpha$  which are finitely generated as  $\mathbb{F}_2$ -vector spaces. By Lemma 8.9 all  $M_\alpha$  are expressible as  $\text{MBP}_{**}(X_\alpha)$  for some  $X_\alpha$  in  $\mathfrak{X}\text{-Mod}_{\text{cell},\mathbb{H}\mathbb{Z}/2}^\heartsuit$ . Therefore,  $M \cong \text{MBP}_{**}(X)$ , where  $X = \text{colim } X_\alpha$ . □

**Remark 8.12**  $\mathcal{G}_{**}\text{-Comod}_{**}^0$  is equivalent to the category of left  $\mathcal{A}_*$ -comodules, where  $\mathcal{A}_*$  is the dual of the topological Steenrod algebra. Hence, the previous result can be rephrased by saying that  $\mathfrak{X}\text{-Mod}_{\text{cell},\mathbb{H}\mathbb{Z}/2}^\heartsuit$  is equivalent to the abelian category of left  $\mathcal{A}_*$ -comodules.

The next proposition, corresponding to [6, Proposition 4.12], provides  $\mathfrak{X}\text{-Mod}_{\text{cell},\mathbb{H}\mathbb{Z}/2}^b$  with a  $t$ -structure.

**Proposition 8.13** *Let  $k$  be a flexible field. Then  $(\mathfrak{X}\text{-Mod}_{\text{cell},\mathbb{H}\mathbb{Z}/2}^{b,\geq 0}, \mathfrak{X}\text{-Mod}_{\text{cell},\mathbb{H}\mathbb{Z}/2}^{b,\leq 0})$  defines a bounded  $t$ -structure on  $\mathfrak{X}\text{-Mod}_{\text{cell},\mathbb{H}\mathbb{Z}/2}^b$ .*

**Proof** Just by the definition of  $\mathfrak{X}\text{-Mod}_{\text{cell},\mathbb{H}\mathbb{Z}/2}^{b,\geq 0}$  and  $\mathfrak{X}\text{-Mod}_{\text{cell},\mathbb{H}\mathbb{Z}/2}^{b,\leq 0}$  the first is closed under suspensions, the second under desuspensions and both under extensions. Clearly

$$\mathfrak{X}\text{-Mod}_{\text{cell},\mathbb{H}\mathbb{Z}/2}^b = \bigcup_{n \in \mathbb{Z}} \mathfrak{X}\text{-Mod}_{\text{cell},\mathbb{H}\mathbb{Z}/2}^{b,\geq n},$$

where  $\mathfrak{X}\text{-Mod}_{\text{cell},\mathbb{H}\mathbb{Z}/2}^{b,\geq n}$  is the  $n^{\text{th}}$  suspension of  $\mathfrak{X}\text{-Mod}_{\text{cell},\mathbb{H}\mathbb{Z}/2}^{b,\geq 0}$ . Next, we consider objects  $X$  and  $Y$  in  $\mathfrak{X}\text{-Mod}_{\text{cell},\mathbb{H}\mathbb{Z}/2}^{b,\geq 0}$  and  $\mathfrak{X}\text{-Mod}_{\text{cell},\mathbb{H}\mathbb{Z}/2}^{b,\leq -1}$  (the first desuspension of  $\mathfrak{X}\text{-Mod}_{\text{cell},\mathbb{H}\mathbb{Z}/2}^{b,\leq 0}$ ), respectively. Then by Corollary 8.7

$$[X, Y] \cong \text{Hom}_{\mathcal{G}_{**}}^{0,0}(\text{MBP}_{**}(X), \text{MBP}_{**}(Y)) \cong 0,$$

since  $\text{MBP}_{**}(Y)$  is concentrated in negative Chow–Novikov degrees while  $\text{MBP}_{**}(X)$  is concentrated in nonnegative Chow–Novikov degrees. Finally, let  $X$  be an object in  $\mathfrak{X}\text{-Mod}_{\text{cell},\mathbb{H}\mathbb{Z}/2}^{b,\geq 0}$ , then  $\text{MBP}(X)$  is concentrated in nonnegative Chow–Novikov degrees. Consider the projection  $\text{MBP}(X) \rightarrow \text{MBP}(X)_0$  that kills all the elements in positive Chow–Novikov degrees, and note that there exists an object  $X_0$  in  $\mathfrak{X}\text{-Mod}_{\text{cell},\mathbb{H}\mathbb{Z}/2}^\heartsuit$  such that  $\text{MBP}(X_0) \cong \text{MBP}(X)_0$ . Now, by Corollary 8.7, this morphism comes from a map  $f: X \rightarrow X_0$  such that  $\Sigma^{-1,0} \text{Cone}(f)$  belongs to  $\mathfrak{X}\text{-Mod}_{\text{cell},\mathbb{H}\mathbb{Z}/2}^{b,\geq 1}$ . Therefore, by [6, Proposition 3.6], the pair  $(\mathfrak{X}\text{-Mod}_{\text{cell},\mathbb{H}\mathbb{Z}/2}^{b,\geq 0}, \mathfrak{X}\text{-Mod}_{\text{cell},\mathbb{H}\mathbb{Z}/2}^{b,\leq 0})$  defines a bounded  $t$ -structure on  $\mathfrak{X}\text{-Mod}_{\text{cell},\mathbb{H}\mathbb{Z}/2}^b$ . □

We are now ready to prove the main result of this section, which corresponds to [6, Theorem 4.13]. In this theorem we identify  $\mathfrak{X}\text{-Mod}_{\text{cell},\mathbb{H}\mathbb{Z}/2}^b$  with the derived category of left  $\mathcal{G}_{**}$ -comodules concentrated in Chow–Novikov degree 0.

**Theorem 8.14** *Let  $k$  be a flexible field. Then there exists a  $t$ -exact equivalence of stable  $\infty$ -categories*

$$\mathcal{D}^b(\mathcal{G}_{**}\text{-Comod}_{**}^0) \xrightarrow{\cong} \mathfrak{X}\text{-Mod}_{\text{cell},\mathbb{H}\mathbb{Z}/2}^b.$$

**Proof** First, by Propositions 8.11 and 8.13,  $(\mathfrak{X}\text{-Mod}_{\text{cell},\mathbb{H}\mathbb{Z}/2}^{b,\geq 0}, \mathfrak{X}\text{-Mod}_{\text{cell},\mathbb{H}\mathbb{Z}/2}^{b,\leq 0})$  defines a bounded  $t$ -structure on  $\mathfrak{X}\text{-Mod}_{\text{cell},\mathbb{H}\mathbb{Z}/2}^b$  whose heart is equivalent to the category of left  $\mathcal{G}_{**}$ -comodules concentrated in Chow–Novikov degree 0, so has enough injectives. Now, let  $X$  and  $Y$  be objects in  $\mathfrak{X}\text{-Mod}_{\text{cell},\mathbb{H}\mathbb{Z}/2}^{\heartsuit}$  such that  $\text{MBP}_{**}(Y)$  is an injective  $\mathcal{G}_{**}$ -comodule. In this case the isotropic Adams–Novikov spectral sequence

$$E_2^{s,t,u} \cong \text{Ext}_{\mathcal{G}_{**}}^{s,t,u}(\text{MBP}_{**}(X), \text{MBP}_{**}(Y)) \Rightarrow [\Sigma^{t-s,u} X, Y]$$

collapses at the second page since the  $E_2$ -page is trivial for  $s \neq 0$ . Hence,

$$\begin{aligned} [\Sigma^{-i} X, Y] &\cong \text{Ext}_{\mathcal{G}_{**}}^{0,-i,0}(\text{MBP}_{**}(X), \text{MBP}_{**}(Y)) \\ &\cong \text{Hom}_{\mathcal{G}_{**}}^{-i,0}(\text{MBP}_{**}(X), \text{MBP}_{**}(Y)) \cong 0 \end{aligned}$$

for any  $i > 0$  since both  $\text{MBP}_{**}(X)$  and  $\text{MBP}_{**}(Y)$  are concentrated in Chow–Novikov degree 0. It follows by [6, Proposition 2.12], which is based on Lurie’s recognition criterion [13, Proposition 1.3.3.7], that there exists a  $t$ -exact equivalence of stable  $\infty$ -categories

$$\mathcal{D}^b(\mathcal{G}_{**}\text{-Comod}_{**}^0) \xrightarrow{\cong} \mathfrak{X}\text{-Mod}_{\text{cell},\mathbb{H}\mathbb{Z}/2}^b$$

extending the equivalence on the hearts. □

**Remark 8.15** Given the identification  $\mathcal{G}_{**} \cong \mathcal{A}_*$ , Theorem 8.14 identifies as triangulated categories the category of bounded isotropic  $\mathbb{H}\mathbb{Z}/2$ -complete cellular spectra with the derived category of left  $\mathcal{A}_*$ -comodules, namely  $\mathcal{D}^b(\mathcal{A}_*\text{-Comod}_*)$ .

By using the same argument as in [6, Corollary 1.2] one is able to obtain an unbounded version of the previous theorem, identifying the whole  $\mathfrak{X}\hat{\wedge}_{\mathbb{H}\mathbb{Z}/2}\text{-Mod}_{\text{cell}}$  with Hovey’s unbounded derived category  $\text{Stable}(\mathcal{G}_{**}\text{-Comod}_{**}^0)$ , which is the same as  $\text{Stable}(\mathcal{A}_*\text{-Comod}_*)$ ; see [7, Section 6].

**Corollary 8.16** *Let  $k$  be a flexible field. Then there exists an equivalence of stable  $\infty$ -categories*

$$\mathfrak{X}\hat{\wedge}_{\mathbb{H}\mathbb{Z}/2}\text{-Mod}_{\text{cell}} \cong \text{Stable}(\mathcal{G}_{**}\text{-Comod}_{**}^0).$$

### 9 The category of isotropic Tate motives

We finish in this section by applying previous results in order to obtain information on the category of isotropic Tate motives  $\mathcal{DM}(k/k)_{\text{Tate}}$ . In particular, we get an easy algebraic description for the hom sets in  $\mathcal{DM}(k/k)_{\text{Tate}}$  between motives of isotropic cellular spectra.

First, we prove the following lemma, which tells us that the isotropic motivic homology of an isotropic spectrum is always a free  $H_{**}(k/k)$ -module.

**Lemma 9.1** *Let  $k$  be a flexible field and  $X$  an object in  $\mathfrak{X}\text{-Mod}$ . Then there exists an isomorphism of left  $H_{**}(k/k)$ -modules*

$$H_{**}^{\text{iso}}(X) \cong H_{**}(k/k) \otimes_{\mathbb{F}_2} \text{MBP}_{**}(X).$$

**Proof** The Hopkins–Morel equivalence (see [8, Theorem 7.12]) implies in particular that  $\text{HZ}/2$  is a quotient spectrum of  $\text{MBP}$ . It follows that  $\text{HZ}/2$  can be obtained from  $\text{MBP}$  by applying cones and homotopy colimits, and so it is an  $\text{MBP}$ -cellular module, from which we get by Theorem 7.4 that

$$\mathfrak{X} \wedge \text{HZ}/2 \cong \bigvee_{\alpha \in A} \Sigma^{p_\alpha, q_\alpha}(\mathfrak{X} \wedge \text{MBP})$$

for some set  $A$ . Now note that, by Theorem 6.6,

$$\begin{aligned} H_{**}(k/k) &\cong \pi_{**}(\mathfrak{X} \wedge \text{HZ}/2) \cong \pi_{**}\left(\bigvee_{\alpha \in A} \Sigma^{p_\alpha, q_\alpha}(\mathfrak{X} \wedge \text{MBP})\right) \\ &\cong \bigoplus_{\alpha \in A} \Sigma^{p_\alpha, q_\alpha} \pi_{**}(\mathfrak{X} \wedge \text{MBP}) \cong \bigoplus_{\alpha \in A} \Sigma^{p_\alpha, q_\alpha} \mathbb{F}_2. \end{aligned}$$

At this point, let  $X$  be an object in  $\mathfrak{X}\text{-Mod}$ . Then

$$\begin{aligned} H_{**}^{\text{iso}}(X) &\cong \pi_{**}(\mathfrak{X} \wedge \text{HZ}/2 \wedge X) \cong \pi_{**}\left(\bigvee_{\alpha \in A} \Sigma^{p_\alpha, q_\alpha}(\mathfrak{X} \wedge \text{MBP} \wedge X)\right) \\ &\cong \bigoplus_{\alpha \in A} \Sigma^{p_\alpha, q_\alpha} \pi_{**}(\mathfrak{X} \wedge \text{MBP} \wedge X) \cong \bigoplus_{\alpha \in A} \Sigma^{p_\alpha, q_\alpha} \text{MBP}_{**}(X) \\ &\cong H_{**}(k/k) \otimes_{\mathbb{F}_2} \text{MBP}_{**}(X). \end{aligned}$$

□

In the next proposition we compute hom sets in the isotropic triangulated category of motives between motives of isotropic cellular spectra. They happen to be isomorphic to hom sets of left  $H_{**}(k/k)$ -modules between the respective isotropic homology.

**Proposition 9.2** *Let  $k$  be a flexible field and  $X$  and  $Y$  objects in  $\mathfrak{X}\text{-Mod}_{\text{cell}}$ . Then there exists an isomorphism*

$$\text{Hom}_{\mathcal{DM}(k/k)_{\text{Tate}}}(M(X), M(Y)) \cong \text{Hom}_{H_{**}(k/k)}(H_{**}^{\text{iso}}(X), H_{**}^{\text{iso}}(Y)).$$

**Proof** Consider the functor

$$H_{**}^{\text{iso}}: \mathcal{DM}(k/k)_{\text{Tate}} \rightarrow H_{**}(k/k)\text{-Mod}_{**}$$

which sends each isotropic Tate motive to the respective isotropic motivic homology, and let  $X$  and  $Y$  be motivic spectra in  $\mathfrak{X}\text{-Mod}_{\text{cell}}$ . Then, by Theorem 7.4, Lemma 9.1 and [19, Proposition 2.4],

$$\begin{aligned} \text{Hom}_{\mathcal{DM}(k/k)_{\text{Tate}}}(M(X), M(Y)) &\cong [X, \mathfrak{X} \wedge \mathbb{H}\mathbb{Z}/2 \wedge Y] \cong [\mathfrak{X} \wedge \text{MBP} \wedge X, \mathfrak{X} \wedge \mathbb{H}\mathbb{Z}/2 \wedge Y]_{\mathfrak{X} \wedge \text{MBP}} \\ &\cong \text{Hom}_{\mathbb{F}_2}(\pi_{**}(\mathfrak{X} \wedge \text{MBP} \wedge X), \pi_{**}(\mathfrak{X} \wedge \mathbb{H}\mathbb{Z}/2 \wedge Y)) \\ &\cong \text{Hom}_{\mathbb{F}_2}(\text{MBP}_{**}(X), H_{**}^{\text{iso}}(Y)) \\ &\cong \text{Hom}_{H_{**}(k/k)}(H_{**}(k/k) \otimes_{\mathbb{F}_2} \text{MBP}_{**}(X), H_{**}^{\text{iso}}(Y)) \\ &\cong \text{Hom}_{H_{**}(k/k)}(H_{**}^{\text{iso}}(X), H_{**}^{\text{iso}}(Y)). \quad \square \end{aligned}$$

**Remark 9.3** The last result suggests that isotropic Tate motives that come from  $\mathcal{SH}(k/k)_{\text{cell}}$  are very special in the sense that hom sets in  $\mathcal{DM}(k/k)_{\text{Tate}}$  between them are described simply in terms of hom sets of free  $H_{**}(k/k)$ -modules. This property does not hold in general, so the next task should be to understand hom sets in  $\mathcal{DM}(k/k)_{\text{Tate}}$  between general isotropic Tate motives and try to describe them in algebraic terms. Unfortunately, since  $H_{**}(k/k)$  is not concentrated in Chow–Novikov degree 0, the strategy used in [6] and adapted in Sections 7 and 8 does not immediately apply. Hence, some new ideas are needed and the hope is to develop them in future work.

### List of symbols

$k$	flexible field with $\text{char}(k) \neq 2$
$\mathcal{SH}(k)$	stable motivic homotopy category over $k$
$\mathcal{SH}(k/k)$	isotropic stable motivic homotopy category over $k$
$\mathcal{DM}(k)$	triangulated category of motives with $\mathbb{Z}/2$ -coefficients over $k$
$\mathcal{DM}(k/k)$	isotropic triangulated category of motives with $\mathbb{Z}/2$ -coefficients over $k$
$\pi_{**}(\cdot)$	stable motivic homotopy groups



$\pi_{**}^{\text{iso}}(\cdot)$	isotropic stable motivic homotopy groups
$H_{**}(\cdot), H^{**}(\cdot)$	motivic homology and cohomology with $\mathbb{Z}/2$ -coefficients
$H_{**}^{\text{iso}}(\cdot), H_{\text{iso}}^{**}(\cdot)$	isotropic motivic homology and cohomology with $\mathbb{Z}/2$ -coefficients
$H_{**}(k), H^{**}(k)$	motivic homology and cohomology with $\mathbb{Z}/2$ -coefficients of $\text{Spec}(k)$
$H_{**}(k/k), H^{**}(k/k)$	isotropic motivic homology and cohomology with $\mathbb{Z}/2$ -coefficients of $\text{Spec}(k)$
$A^{**}(k), \mathcal{A}_{**}(k)$	mod 2 motivic Steenrod algebra and its dual
$A^{**}(k/k), \mathcal{A}_{**}(k/k)$	mod 2 isotropic motivic Steenrod algebra and its dual
$\mathcal{A}^*, \mathcal{A}_*$	mod 2 topological Steenrod algebra and its dual
$\mathcal{G}^{**}, \mathcal{G}_{**}$	bigraded mod 2 topological Steenrod algebra and its dual, ie $\mathcal{G}^{2q,q} = \mathcal{A}^q$ and $\mathcal{G}^{p,q} = 0$ for $p \neq 2q$ , similar for the dual
$\mathcal{M}^{**}$	Milnor subalgebra $\Lambda_{\mathbb{F}_2}(Q_i)_{i \geq 0}$ of $\mathcal{A}^{**}(k/k)$ where the $Q_i$ are the Milnor operations in bidegrees $(2^i - 1)[2^{i+1} - 1]$
S	motivic sphere spectrum
HZ/2	motivic Eilenberg–Mac Lane spectrum with $\mathbb{Z}/2$ -coefficients
MGL	motivic algebraic cobordism spectrum
MBP	motivic Brown–Peterson spectrum at the prime 2
$\mathfrak{X}$	isotropic sphere spectrum

## References

- [1] **T Bachmann, H J Kong, G Wang, Z Xu**, *The Chow  $t$ -structure on the  $\infty$ -category of motivic spectra*, Ann. of Math. 195 (2022) 707–773 MR Zbl
- [2] **A K Bousfield**, *The localization of spectra with respect to homology*, Topology 18 (1979) 257–281 MR Zbl
- [3] **D Dugger, D C Isaksen**, *Motivic cell structures*, Algebr. Geom. Topol. 5 (2005) 615–652 MR Zbl
- [4] **D Dugger, D C Isaksen**, *The motivic Adams spectral sequence*, Geom. Topol. 14 (2010) 967–1014 MR Zbl
- [5] **B Gheorghe**, *The motivic cofiber of  $\tau$* , Doc. Math. 23 (2018) 1077–1127 MR Zbl
- [6] **B Gheorghe, G Wang, Z Xu**, *The special fiber of the motivic deformation of the stable homotopy category is algebraic*, Acta Math. 226 (2021) 319–407 MR Zbl
- [7] **M Hovey**, *Homotopy theory of comodules over a Hopf algebroid*, from “Homotopy theory: relations with algebraic geometry, group cohomology, and algebraic  $K$ -theory” (P Goerss, S Priddy, editors), Contemp. Math. 346, Amer. Math. Soc., Providence, RI (2004) 261–304 MR Zbl
- [8] **M Hoyois**, *From algebraic cobordism to motivic cohomology*, J. Reine Angew. Math. 702 (2015) 173–226 MR Zbl

- [9] **D C Isaksen**, *Stable stems*, Mem. Amer. Math. Soc. 1269, Amer. Math. Soc., Providence, RI (2019) MR Zbl
- [10] **P S Landweber**, *Associated prime ideals and Hopf algebras*, J. Pure Appl. Algebra 3 (1973) 43–58 MR
- [11] **T Lawson**, *Secondary power operations and the Brown–Peterson spectrum at the prime 2*, Ann. of Math. 188 (2018) 513–576 MR Zbl
- [12] **M Levine**, *Aspects of enumerative geometry with quadratic forms*, Doc. Math. 25 (2020) 2179–2239 MR Zbl
- [13] **J Lurie**, *Higher algebra*, preprint (2017) Available at <https://www.math.ias.edu/~lurie/papers/HA.pdf>
- [14] **L Mantovani**, *Localizations and completions in motivic homotopy theory*, preprint (2018) arXiv 1810.04134
- [15] **F Morel**, *On the motivic  $\pi_0$  of the sphere spectrum*, from “Axiomatic, enriched and motivic homotopy theory” (J P C Greenlees, editor), NATO Sci. Ser. II Math. Phys. Chem. 131, Kluwer, Dordrecht (2004) 219–260 MR Zbl
- [16] **F Morel, V Voevodsky**,  $\mathbb{A}^1$ –homotopy theory of schemes, Inst. Hautes Études Sci. Publ. Math. 90 (1999) 45–143 MR Zbl
- [17] **N Naumann, M Spitzweck, P A Østvær**, *Motivic Landweber exactness*, Doc. Math. 14 (2009) 551–593 MR Zbl
- [18] **D C Ravenel**, *Complex cobordism and stable homotopy groups of spheres*, Pure and Applied Mathematics 121, Academic, Orlando, FL (1986) MR Zbl
- [19] **F Tanania**, *Isotropic stable motivic homotopy groups of spheres*, Adv. Math. 383 (2021) art. id. 107696 MR Zbl
- [20] **G Vezzosi**, *Brown–Peterson spectra in stable  $\mathbb{A}^1$ –homotopy theory*, Rend. Sem. Mat. Univ. Padova 106 (2001) 47–64 MR Zbl
- [21] **A Vishik**, *Isotropic motives*, J. Inst. Math. Jussieu 21 (2022) 1271–1330 MR Zbl
- [22] **V Voevodsky**,  $\mathbb{A}^1$ –homotopy theory, from “Proceedings of the International Congress of Mathematicians, I” (G Fischer, U Rehmann, editors), Deutsche Mathematiker Vereinigung, Berlin (1998) 579–604 MR Zbl
- [23] **V Voevodsky**, *Triangulated categories of motives over a field*, from “Cycles, transfers, and motivic homology theories” (J N Mather, E M Stein, editors), Ann. of Math. Stud. 143, Princeton Univ. Press (2000) 188–238 MR Zbl
- [24] **V Voevodsky**, *Reduced power operations in motivic cohomology*, Publ. Math. Inst. Hautes Études Sci. 98 (2003) 1–57 MR Zbl

Mathematisches Institut, Ludwig-Maximilians-Universität München  
Munich, Germany

fabio.tanania@gmail.com

Proposed: Jesper Grodal  
Seconded: Marc Levine, Stefan Schwede

Received: 12 March 2021  
Revised: 6 December 2021

## Guidelines for Authors

### Submitting a paper to Geometry & Topology

Papers must be submitted using the upload page at the GT website. You will need to choose a suitable editor from the list of editors' interests and to supply MSC codes.

The normal language used by the journal is English. Articles written in other languages are acceptable, provided your chosen editor is comfortable with the language and you supply an additional English version of the abstract.

### Preparing your article for Geometry & Topology

At the time of submission you need only supply a PDF file. Once accepted for publication, the paper must be supplied in  $\LaTeX$ , preferably using the journal's class file. More information on preparing articles in  $\LaTeX$  for publication in GT is available on the GT website.

### arXiv papers

If your paper has previously been deposited on the arXiv, we will need its arXiv number at acceptance time. This allows us to deposit the DOI of the published version on the paper's arXiv page.

### References

Bibliographical references should be listed alphabetically at the end of the paper. All references in the bibliography should be cited at least once in the text. Use of Bib $\TeX$  is preferred but not required. Any bibliographical citation style may be used, but will be converted to the house style (see a current issue for examples).

### Figures

Figures, whether prepared electronically or hand-drawn, must be of publication quality. Fuzzy or sloppily drawn figures will not be accepted. For labeling figure elements consider the pinlabel  $\LaTeX$  package, but other methods are fine if the result is editable. If you're not sure whether your figures are acceptable, check with production by sending an email to [graphics@msp.org](mailto:graphics@msp.org).

### Proofs

Page proofs will be made available to authors (or to the designated corresponding author) in PDF format. Failure to acknowledge the receipt of proofs or to return corrections within the requested deadline may cause publication to be postponed.

# GEOMETRY & TOPOLOGY

Volume 27 Issue 5 (pages 1657–2048) 2023

---

- A sharp lower bound on fixed points of surface symplectomorphisms in each mapping class 1657  
ANDREW COTTON-CLAY
- High-energy harmonic maps and degeneration of minimal surfaces 1691  
CHARLES OUYANG
- Orbifold bordism and duality for finite orbispectra 1747  
JOHN PARDON
- Higher genus FJRW invariants of a Fermat cubic 1845  
JUN LI, YEFENG SHEN and JIE ZHOU
- Compact moduli of elliptic K3 surfaces 1891  
KENNETH ASCHER and DORI BEJLERI
- Chern characters for supersymmetric field theories 1947  
DANIEL BERWICK-EVANS
- Isotopy of the Dehn twist on  $K3 \# K3$  after a single stabilization 1987  
JIANFENG LIN
- Cellular objects in isotropic motivic categories 2013  
FABIO TANANIA