

Epimorphisms between 2–bridge link groups

TOMOTADA OHTSUKI

ROBERT RILEY

MAKOTO SAKUMA

We give a systematic construction of epimorphisms between 2–bridge link groups. Moreover, we show that 2–bridge links having such an epimorphism between their link groups are related by a map between the ambient spaces which only have a certain specific kind of singularity. We show applications of these epimorphisms to the character varieties for 2–bridge links and π_1 –dominating maps among 3–manifolds.

[57M25](#); [57M05](#), [57M50](#)

Dedicated to the memory of Professor Heiner Zieschang

1 Introduction

For a knot or a link, K , in S^3 , the fundamental group $\pi_1(S^3 - K)$ of the complement is called the *knot group* or the *link group* of K , and is denoted by $G(K)$. This paper is concerned with the following problem.

For a given knot (or link) K , characterize which knots (or links) \tilde{K} admit an epimorphism $G(\tilde{K}) \rightarrow G(K)$.

This topic has been studied in various places in the literature, and, in particular, a complete classification has been obtained when K is the $(2, p)$ torus knot and \tilde{K} is a 2–bridge knot, and when K and \tilde{K} are prime knots with up to 10 crossings; for details, see [Section 2](#). A motivation for considering such epimorphisms is that they induce a partial order on the set of prime knots (see [Section 2](#)), and we expect that new insights into the theory of knots may be obtained in the future by studying such a structure, in relation with topological properties and algebraic invariants of knots related to knot groups.

In this paper, we give a systematic construction of epimorphisms between 2–bridge link groups. We briefly review 2–bridge links; for details see [Section 3](#).

For $r \in \widehat{\mathbb{Q}} := \mathbb{Q} \cup \{\infty\}$, the 2–bridge link $K(r)$ is the link obtained by gluing two trivial 2–component tangles in B^3 along $(S^2, 4 \text{ points})$ where the loop in $S^2 - (4 \text{ points})$ of slope ∞ is identified with that of slope r , namely the double cover of the gluing map ($\in \text{Aut}(T^2) = SL(2, \mathbb{Z})$) takes ∞ to r , where $SL(2, \mathbb{Z})$ acts on $\widehat{\mathbb{Q}}$ by the linear fractional transformation. To be more explicit, for a continued fraction expansion

$$r = [a_1, a_2, \dots, a_m] = \frac{1}{a_1 + \frac{1}{a_2 + \dots + \frac{1}{a_m}}},$$

a plat presentation of $K(r)$ is given as shown in [Figure 1](#).

We give a systematic construction of epimorphisms between 2–bridge link groups in the following theorem, which is proved in [Section 4](#).

Theorem 1.1 *There is an epimorphism from the 2–bridge link group $G(K(\tilde{r}))$ to the 2–bridge link group $G(K(r))$, if \tilde{r} belongs to the $\widehat{\Gamma}_r$ –orbit of r or ∞ . Moreover the epimorphism sends the upper meridian pair of $K(\tilde{r})$ to that of $K(r)$.*

Here, we define the $\widehat{\Gamma}_r$ –action on $\widehat{\mathbb{Q}}$ below, and we give the definition of an upper meridian pair in [Section 3](#). For some simple values of r , the theorem is reduced to [Examples 4.1–4.3](#).

The $\widehat{\Gamma}_r$ –action on $\widehat{\mathbb{Q}}$ is defined as follows. Let \mathcal{D} be the *modular tessellation*, that is, the tessellation of the upper half space \mathbb{H}^2 by ideal triangles which are obtained from the ideal triangle with the ideal vertices $0, 1, \infty \in \widehat{\mathbb{Q}}$ by repeated reflection in the edges. Then $\widehat{\mathbb{Q}}$ is identified with the set of the ideal vertices of \mathcal{D} . For each $r \in \widehat{\mathbb{Q}}$, let Γ_r be the group of automorphisms of \mathcal{D} generated by reflections in the edges of \mathcal{D} with an endpoint r . It should be noted that Γ_r is isomorphic to the infinite dihedral group and the region bounded by two adjacent edges of \mathcal{D} with an endpoint r is a fundamental domain for the action of Γ_r on \mathbb{H}^2 . Let $\widehat{\Gamma}_r$ be the group generated by Γ_r and Γ_∞ . When $r \in \mathbb{Q} - \mathbb{Z}$, $\widehat{\Gamma}_r$ is equal to the free product $\Gamma_r * \Gamma_\infty$, having a fundamental domain shown in [Figure 1](#). When $r \in \mathbb{Z} \cup \{\infty\}$, we concretely describe $\widehat{\Gamma}_r$ in [Example 4.1](#) and [Example 4.2](#). By using the fundamental domain of the group $\widehat{\Gamma}_r$, we can give a practical algorithm to determine whether a given rational number \tilde{r} belongs to the $\widehat{\Gamma}_r$ –orbit of ∞ or r (see [Section 5.1](#)). In fact, [Proposition 5.1](#) characterizes such a rational number \tilde{r} in terms of its continued fraction expansion.

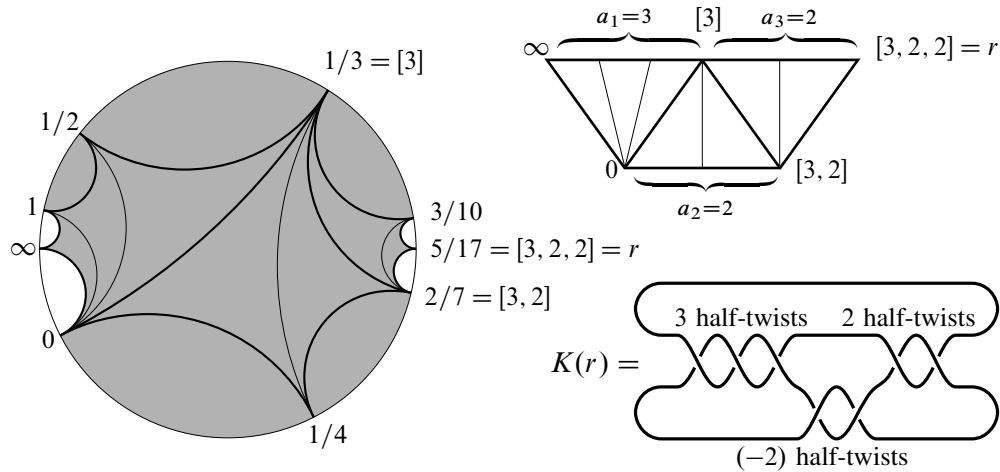

Figure 1: A fundamental domain of $\hat{\Gamma}_r$ in the modular tessellation (the shaded domain), the linearization of (the core part of) the fundamental domain, and the 2-bridge knot $K(r)$, for $r = 5/17 = [3, 2, 2]$

Now we study topological characterization of a link \tilde{K} having an epimorphism $G(\tilde{K}) \rightarrow G(K)$ for a given link K . We call a continuous map $f: (S^3, \tilde{K}) \rightarrow (S^3, K)$ proper if $\tilde{K} = f^{-1}(K)$. Since a proper map induces a map between link complements, it further induces a homomorphism $G(\tilde{K}) \rightarrow G(K)$ preserving peripheral structure. Conversely, any epimorphism $G(\tilde{K}) \rightarrow G(K)$ for a nonsplit link K , preserving peripheral structure, is induced by some proper map $(S^3, \tilde{K}) \rightarrow (S^3, K)$, because the complement of a nonsplit link is aspherical. Thus, we can obtain \tilde{K} as $f^{-1}(K)$ for a suitably chosen map $f: S^3 \rightarrow S^3$; in [Question 9.2](#) we propose a conjecture to characterize \tilde{K} from K in this direction.

For 2-bridge links, we have the following theorem which implies that, for each epimorphism $G(K(\tilde{r})) \rightarrow G(K(r))$ in [Theorem 1.1](#), we can topologically characterize $K(\tilde{r})$ as the preimage $f^{-1}(K(r))$ for some specific kind of a proper map f . For the proof of the theorem, see [Section 5](#), [Section 6](#) and [Figure 2](#).

Theorem 1.2 *If \tilde{r} belongs to the $\hat{\Gamma}_r$ -orbit of r or ∞ , then there is a proper branched fold map $f: (S^3, K(\tilde{r})) \rightarrow (S^3, K(r))$ which induces an epimorphism $G(K(\tilde{r})) \rightarrow G(K(r))$, such that its fold surface is the disjoint union of level 2-spheres and its branch curve is a link of index 2 disjoint to $K(\tilde{r})$, each of whose components lie in a level 2-sphere.*

Here, we explain the terminology in the theorem. More detailed properties of the map f are given in [Proposition 6.2](#) and [Remark 6.3](#).

By a *branched fold map*, we mean a map between 3-manifolds such that, for each point p in the source manifold, there exist local coordinates around p and $f(p)$ such that f is given by one of the following formulas in the neighborhood of p :

$$\begin{aligned} f(x_1, x_2, x_3) &= (x_1, x_2, x_3) \\ f(x_1, x_2, x_3) &= (x_1^2, x_2, x_3) \\ f(z, x_3) &= (z^n, x_3) \quad (z = x_1 + x_2\sqrt{-1}) \end{aligned}$$

When p and $f(p)$ have such coordinates around them, we call p a *regular point*, a *fold point* or a *branch point* of *index* n , accordingly. The set of fold points forms a surface in the source manifold, which we call the *fold surface* of f . The set of branch points forms a link in the source manifold, which we call the *branch curve* of f . (If f further allowed “fold branch points” which are defined by $f(x_1, z) = (x_1^2, z^2)$ for suitable local coordinates where $z = x_2 + x_3\sqrt{-1}$, and if the index of every branch point is 2, f is called a “nice” map in Honma [17]. It is shown [17] that any continuous map between 3-manifolds can be approximated by a “nice” map.)

A *height function* for $K(r)$ is a function $h : S^3 \rightarrow [-1, 1]$ such that $h^{-1}(t)$ is a 2-sphere intersecting $K(r)$ transversely in four points or a disk intersecting $K(r)$ transversely in two points in its interior according as $t \in (-1, 1)$ or $\{\pm 1\}$. We call the 2-sphere $h^{-1}(t)$ with $t \in (-1, 1)$ a *level 2-sphere*.

[Theorem 1.1](#) and [Theorem 1.2](#) have applications to the character varieties of 2-bridge links and π_1 -dominating maps among 3-manifolds. These are given in [Section 7](#) and [Section 8](#).

The paper is organized as follows; see also [Figure 2](#) for a sketch plan to prove [Theorem 1.1](#) and [Theorem 1.2](#). In [Section 2](#), we quickly review known facts concerning epimorphisms between knot groups, in order to explain background and motivation for the study of epimorphisms between knot groups. In [Section 3](#), we review basic properties of 2-bridge links. In [Section 4](#), we prove [Theorem 1.1](#), constructing epimorphisms $G(K(\tilde{r})) \rightarrow G(K(r))$. In [Section 5](#), we show that if \tilde{r} belongs to the $\widehat{\Gamma}_r$ -orbit of r or ∞ , then \tilde{r} has a continued fraction expansion of a certain specific form in [Proposition 5.1](#), and equivalently $K(\tilde{r})$ has a plat presentation of a certain specific form in [Proposition 5.2](#). In [Section 6](#), we give an explicit construction of the desired proper map $(S^3, K(\tilde{r})) \rightarrow (S^3, K(r))$ under the setting of [Proposition 5.2](#) (see [Theorem 6.1](#)). This together with [Proposition 5.2](#) gives the proof of [Theorem 1.2](#). We also describe further properties of the map in [Section 6](#). In [Section 7](#) and [Section 8](#), we show applications of [Theorem 1.1](#) and [Theorem 1.2](#) to the character varieties for 2-bridge links and π_1 -dominating maps among 3-manifolds. In [Section 9](#), we propose some questions related to [Theorem 1.1](#) and [Theorem 1.2](#).

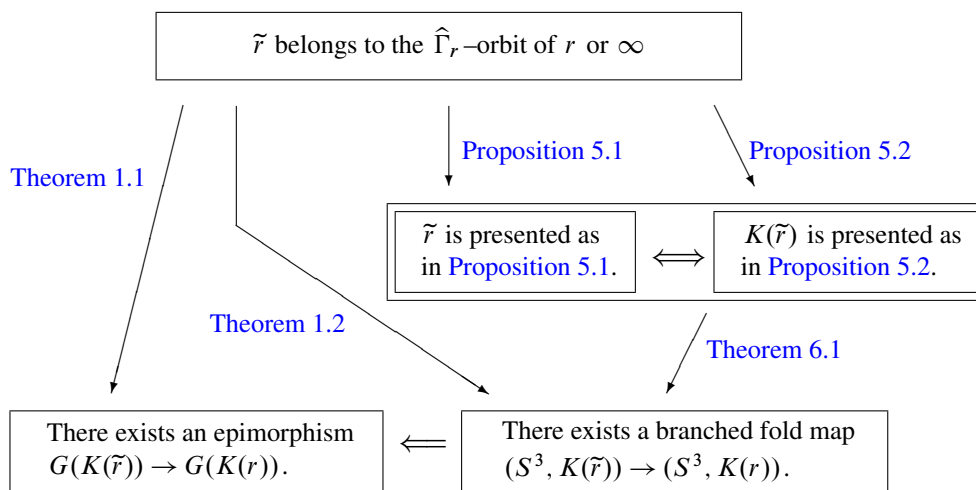

Figure 2: Sketch plan to prove Theorem 1.1 and Theorem 1.2

Personal history This paper is actually an expanded version of the unfinished joint paper [30] by the first and second authors and the announcement [36] by the third author. As is explained in the introduction of Riley [34], the first and second authors proved Theorem 6.1, motivated by the study of reducibility of the space of irreducible $SL(2, \mathbb{C})$ representations of 2-bridge knot groups, and obtained (a variant) of Corollary 7.1. On the other hand, the last author discovered Theorem 1.1 while doing joint research [1] with H Akiyoshi, M Wada and Y Yamashita on the geometry of 2-bridge links. This was made when he was visiting G Burde in the summer of 1997, after learning several examples found by Burde and his student, F Opitz, through computer experiments on representation spaces. The first and third authors realized that Theorem 1.1 and Theorem 6.1 are equivalent in the autumn of 1997, and agreed to write a joint paper with the second author. But, very sadly, the second author passed away on March 4, 2000, before the joint paper was completed. May Professor Robert Riley rest in peace.

Acknowledgments The first author would like to thank Osamu Saeki for helpful comments. The third author would like to thank Gerhard Burde and Felix Opitz for teaching him of their experimental results on 2-bridge knot groups. He would also like to thank Michel Boileau, Kazuhiro Ichihara and Alan Reid for useful information. The first and the third authors would like to thank Teruaki Kitano and Masaaki Suzuki for informing the authors of their recent results. They would also like to thank Andrew Kriker, Daniel Moskovich and Kenneth Shackleton for useful information. Finally, they would like to thank the referee for very careful reading and helpful comments.

2 Epimorphisms between knot groups

In this section, we summarize topics and known results related to epimorphisms between knot groups, in order to give background and motivation to study epimorphisms between knot groups.

We have a partial order on the set of prime knots, by setting $\tilde{K} \geq K$ if there is an epimorphism $G(\tilde{K}) \rightarrow G(K)$. A nontrivial part of the proof is to show that $K_1 \geq K_2$ and $K_1 \leq K_2$ imply $K_1 = K_2$, which is shown from the following two facts. The first one is that we have a partial order on the set of knot groups of all knots; its proof is due to the Hopfian property (see, for example, Silver–Whitten [40, Proposition 3.2]). The second fact is that prime knots are determined by their knot groups (see, for example, Kawauchi [19, Theorem 6.1.12]).

The existence and nonexistence of epimorphisms between knot groups for some families of knots have been determined. González–Acuña and Ramírez [12] gave a certain topological characterization of those knots whose knot groups have epimorphisms to torus knot groups, in particular, they determined in [13] the 2–bridge knots whose knot groups have epimorphisms to the $(2, p)$ torus knot group. Kitano–Suzuki–Wada [25] gave an effective criterion for the existence of an epimorphism among two given knot groups, in terms of the twisted Alexander polynomials, extending the well-known criterion that the Alexander polynomial of \tilde{K} is divisible by that of K if there is an epimorphism $G(\tilde{K}) \rightarrow G(K)$. By using the criterion, Kitano–Suzuki [23] gave a complete list of such pairs (\tilde{K}, K) among the prime knots with up to 10 crossings.

The finiteness of K admitting an epimorphism $G(\tilde{K}) \rightarrow G(K)$ for a given \tilde{K} was conjectured by Simon [22, Problem 1.12], and it was partially solved by Boileau–Rubinstein–Wang [4], under the assumption that the epimorphisms are induced by nonzero degree proper maps.

A systematic construction of epimorphisms between knot groups is given by Kawauchi’s imitation theory [20]; in fact, his theory constructs an imitation \tilde{K} of K which shares various topological properties with K , and, in particular, there is an epimorphism between their knot groups.

From the viewpoint of maps between ambient spaces, any epimorphism $G(\tilde{K}) \rightarrow G(K)$ for a nonsplit link K , preserving peripheral structure, is induced by some proper map $f: (S^3, \tilde{K}) \rightarrow (S^3, K)$, as mentioned in the introduction. The index of the image $f_*(G(\tilde{K}))$ in $G(K)$ is a divisor of the degree of f (see Hempel [16, Lemma 15.2]). In particular, if f is of degree 1, then f_* induces an epimorphism between the knot groups. Thus the problem of epimorphisms between knot groups is related to the study of proper maps between ambient spaces, more generally, maps between 3–manifolds.

This direction has been extensively studied in various literatures (see Boileau–Wang [3], Boileau–Rubinstein–Wang [4], Kawauchi [20], Reid–Wang–Zhou [31], Silver–Whitten [40], Soma [41; 42], Wang [43] and references therein).

3 Rational tangles and 2-bridge links

In this section, we recall basic definitions and facts concerning the 2-bridge knots and links.

Consider the discrete group, H , of isometries of the Euclidean plane \mathbb{R}^2 generated by the π -rotations around the points in the lattice \mathbb{Z}^2 . Set $(\mathcal{S}^2, \mathbf{P}) = (\mathbb{R}^2, \mathbb{Z}^2)/H$ and call it the *Conway sphere*. Then \mathcal{S}^2 is homeomorphic to the 2-sphere, and \mathbf{P} consists of four points in \mathcal{S}^2 . We also call \mathcal{S}^2 the Conway sphere. Let $\mathcal{S} := \mathcal{S}^2 - \mathbf{P}$ be the complementary 4-times punctured sphere. For each $r \in \widehat{\mathbb{Q}} := \mathbb{Q} \cup \{\infty\}$, let α_r be the simple loop in \mathcal{S} obtained as the projection of the line in $\mathbb{R}^2 - \mathbb{Z}^2$ of slope r . Then α_r is *essential* in \mathcal{S} , ie, it does not bound a disk in \mathcal{S} and is not homotopic to a loop around a puncture. Conversely, any essential simple loop in \mathcal{S} is isotopic to α_r for a unique $r \in \widehat{\mathbb{Q}}$. Then r is called the *slope* of the simple loop. Similarly, any simple arc δ in \mathcal{S}^2 joining two different points in \mathbf{P} such that $\delta \cap \mathbf{P} = \partial\delta$ is isotopic to the image of a line in \mathbb{R}^2 of some slope $r \in \widehat{\mathbb{Q}}$ which intersects \mathbb{Z}^2 . We call r the *slope* of δ .

A *trivial tangle* is a pair (B^3, t) , where B^3 is a 3-ball and t is a union of two arcs properly embedded in B^3 which is parallel to a union of two mutually disjoint arcs in ∂B^3 . Let τ be the simple unknotted arc in B^3 joining the two components of t as illustrated in Figure 3. We call it the *core tunnel* of the trivial tangle. Pick a base point x_0 in $\text{int } \tau$, and let (μ_1, μ_2) be the generating pair of the fundamental group $\pi_1(B^3 - t, x_0)$ each of which is represented by a based loop consisting of a small peripheral simple loop around a component of t and a subarc of τ joining the circle to x . For any base point $x \in B^3 - t$, the generating pair of $\pi_1(B^3 - t, x)$ corresponding to the generating pair (μ_1, μ_2) of $\pi_1(B^3 - t, x_0)$ via a path joining x to x_0 is denoted by the same symbol. The pair (μ_1, μ_2) is unique up to (i) reversal of the order, (ii) replacement of one of the members with its inverse, and (iii) simultaneous conjugation. We call the equivalence class of (μ_1, μ_2) the *meridian pair* of the fundamental group $\pi_1(B^3 - t)$.

By a *rational tangle*, we mean a trivial tangle (B^3, t) which is endowed with a homeomorphism from $\partial(B^3, t)$ to $(\mathcal{S}^2, \mathbf{P})$. Through the homeomorphism we identify the boundary of a rational tangle with the Conway sphere. Thus the slope of an essential simple loop in $\partial B^3 - t$ is defined. We define the *slope* of a rational tangle to be the slope of an essential loop on $\partial B^3 - t$ which bounds a disk in B^3 separating the components

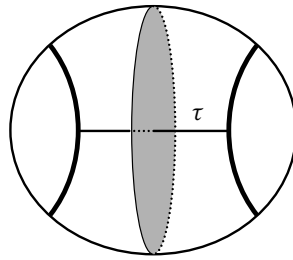

Figure 3: A trivial tangle

of t . (Such a loop is unique up to isotopy on $\partial B^3 - t$ and is called a *meridian* of the rational tangle.) We denote a rational tangle of slope r by $(B^3, t(r))$. By van Kampen's theorem, the fundamental group $\pi_1(B^3 - t(r))$ is identified with the quotient $\pi_1(\mathcal{S})/\langle\langle \alpha_r \rangle\rangle$, where $\langle\langle \alpha_r \rangle\rangle$ denotes the normal closure.

For each $r \in \widehat{\mathbb{Q}}$, the *2-bridge link* $K(r)$ of slope r is defined to be the sum of the rational tangles of slopes ∞ and r , namely, $(S^3, K(r))$ is obtained from $(B^3, t(\infty))$ and $(B^3, t(r))$ by identifying their boundaries through the identity map on the Conway sphere (S^2, \mathcal{P}) . (Recall that the boundaries of rational tangles are identified with the Conway sphere.) $K(r)$ has one or two components according as the denominator of r is odd or even. We call $(B^3, t(\infty))$ and $(B^3, t(r))$, respectively, the *upper tangle* and *lower tangle* of the 2-bridge link. The image of the core tunnels for $(B^3, t(\infty))$ and $(B^3, t(r))$ are called the *upper tunnels* and *lower tunnel* for the 2-bridge link.

We describe a plat presentation of $K(r)$, as follows. Choose a continued fraction expansion of r ,

$$r = [a_1, a_2, \dots, a_m].$$

When m is odd, we have a presentation,

$$r = B \cdot \infty \quad \text{where } B = \begin{pmatrix} 1 & 0 \\ a_1 & 1 \end{pmatrix} \begin{pmatrix} 1 & a_2 \\ 0 & 1 \end{pmatrix} \begin{pmatrix} 1 & 0 \\ a_3 & 1 \end{pmatrix} \cdots \begin{pmatrix} 1 & 0 \\ a_m & 1 \end{pmatrix},$$

and B acts on $\widehat{\mathbb{Q}}$ by the linear fractional transformation. Then $K(r)$ has the following presentation, where the boxed " a_i " implies a_i half-twists.

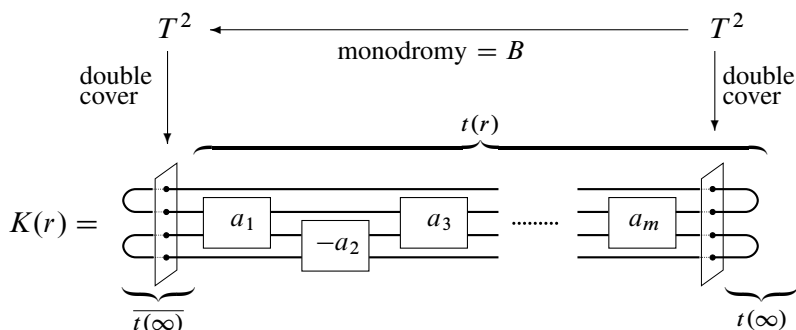

Similarly, when m is even:

$$r = \begin{pmatrix} 1 & 0 \\ a_1 & 1 \end{pmatrix} \begin{pmatrix} 1 & a_2 \\ 0 & 1 \end{pmatrix} \begin{pmatrix} 1 & 0 \\ a_3 & 1 \end{pmatrix} \cdots \begin{pmatrix} 1 & a_m \\ 0 & 1 \end{pmatrix} \cdot 0,$$

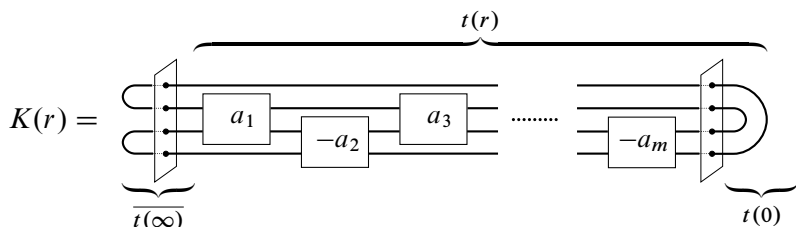

We recall Schubert's classification [37] of the 2-bridge links (cf [7]).

Theorem 3.1 (Schubert) *Two 2-bridge links $K(q/p)$ and $K(q'/p')$ are equivalent, if and only if the following conditions hold.*

- (1) $p = p'$.
- (2) *Either $q \equiv \pm q' \pmod{p}$ or $qq' \equiv \pm 1 \pmod{p}$.*

Moreover, if the above conditions are satisfied, there is a homeomorphism

$$f: (S^3, K(q/p)) \rightarrow (S^3, K(q'/p'))$$

which satisfies the following conditions.

- (1) *If $q \equiv q' \pmod{p}$ or $qq' \equiv 1 \pmod{p}$, then f preserves the orientation of S^3 . Otherwise, f reverses the orientation of S^3 .*
- (2) *If $q \equiv \pm q' \pmod{p}$, then f maps the upper tangle of $K(q/p)$ to that of $K(q'/p')$. If $qq' \equiv 1 \pmod{p}$, then f maps the upper tangle of $K(q/p)$ to the lower tangle of $K(q'/p')$.*

By van Kampen's theorem, the link group $G(K(r)) = \pi_1(S^3 - K(r))$ of $K(r)$ is identified with $\pi_1(\mathcal{S})/\langle\langle\alpha_\infty, \alpha_r\rangle\rangle$. We call the image in the link group of the meridian pair of the fundamental group $\pi_1(B^3 - t(\infty))$ (resp. $\pi_1(B^3 - t(r))$) the *upper meridian pair* (resp. *lower meridian pair*). The link group is regarded as the quotient of the rank 2 free group, $\pi_1(B^3 - t(\infty)) \cong \pi_1(\mathcal{S})/\langle\langle\alpha_\infty\rangle\rangle$, by the normal closure of α_r . This gives a one-relator presentation of the link group, and is actually equivalent to the upper presentation [9]. Similarly, the link group is regarded as the quotient of the rank 2 free group $\pi_1(B^3 - t(r)) \cong \pi_1(\mathcal{S})/\langle\langle\alpha_r\rangle\rangle$ by the normal closure of α_∞ , which in turn gives the lower presentation of the link group. These facts play an important role in the next section.

4 Constructing an epimorphism $G(K(\tilde{r})) \rightarrow G(K(r))$

In this section, we prove [Theorem 1.1](#), which states the existence of an epimorphism $G(K(\tilde{r})) \rightarrow G(K(r))$. Before proving the theorem, we explain special cases of the theorem for some simple values of r .

Example 4.1 If $r = \infty$, then $K(r)$ is a trivial 2-component link. Further, $\hat{\Gamma}_r = \Gamma_r = \Gamma_\infty$. Thus the region bounded by the edges $\langle\infty, 0\rangle$ and $\langle\infty, 1\rangle$ is a fundamental domain for the action of $\hat{\Gamma}_r$ on \mathbb{H}^2 . Hence, the assumption of [Theorem 1.1](#) is satisfied if and only if $\tilde{r} = \infty$. This reflects the fact that a link is trivial if and only if its link group is a free group.

Example 4.2 If $r \in \mathbb{Z}$, then $K(r)$ is a trivial knot. Further, $\hat{\Gamma}_r$ is equal to the group generated by the reflections in the edges of any of \mathcal{D} . In particular, any ideal triangle of \mathcal{D} is a fundamental domain for the action of $\hat{\Gamma}_r$ on \mathbb{H}^2 . Hence, $\hat{\Gamma}_r$ acts transitively on $\hat{\mathbb{Q}}$ and every $\tilde{r} \in \hat{\mathbb{Q}}$ satisfies the assumption of [Theorem 1.1](#). This reflects the fact that there is an epimorphism from the link group of an arbitrary link L to \mathbb{Z} , the knot group of the trivial knot, sending meridians to meridians.

Example 4.3 If $r \equiv 1/2 \pmod{\mathbb{Z}}$, then $K(r)$ is a Hopf link. Further, $\tilde{r} = q/p$ satisfies the assumption of [Theorem 1.1](#) if and only if p is even, ie, $K(\tilde{r})$ is a 2-component link. This reflects the fact that the link group of an arbitrary 2-component link has an epimorphism to the link group, $\mathbb{Z} \oplus \mathbb{Z}$, of the Hopf link.

The proof of [Theorem 1.1](#) is based on the following simple observation.

Lemma 4.4 For each rational tangle $(B^3, t(r))$, the following holds.

- (1) For each $s \in \widehat{\mathbb{Q}}$, the simple loop α_s is nullhomotopic in $B^3 - t(r)$ if and only if $s = r$.
- (2) Let s and s' be elements of $\widehat{\mathbb{Q}}$ which belongs to the same Γ_r -orbit. The the simple loops α_s and $\alpha_{s'}$ are homotopic in $B^3 - t(r)$.

Proof The linear action of $SL(2, \mathbb{Z})$ on \mathbb{R}^2 descends to an action on (S^2, \mathbf{P}) , and the assertions in this lemma are invariant by the action. Thus we may assume $r = \infty$.

(1) Let γ_1 and γ_2 be arcs in $\partial(B^3, t(r))$ of slope ∞ , namely $(\gamma_1 \cup \gamma_2) \cap \partial t(\infty) = \partial t(\infty)$ and $\gamma_1 \cup \gamma_2$ is parallel to $t(\infty)$ in B^3 . Then $\pi_1(B^3 - t(\infty))$ is the free group of rank 2 generated by the meridian pair $\{\mu_1, \mu_2\}$, and the cyclic word in $\{\mu_1, \mu_2\}$ obtained by reading the intersection of the loop α_s with $\gamma_1 \cup \gamma_2$ represent the free homotopy class of α_s . (After a suitable choice of orientation, a positive intersection with γ_i corresponds to μ_i . If $s \neq 0$, then α_s intersects γ_1 and γ_2 alternatively, and hence the corresponding word is a reduce word. Thus α_s is not nullhomotopic in $B^3 - t(r)$ if $s \neq \infty$. Since the converse is obvious, we obtain the desired result.

(2) Let A be the reflection of \mathcal{D} in the edge $\langle 0, \infty \rangle$, and let B be the parabolic transformation of \mathcal{D} around the vertex ∞ by 2 units. Then their actions on $\widehat{\mathbb{Q}}$ is given by $A(s) = -s$ and $B(s) = s + 2$. Since A and B generates the group Γ_∞ , we have only to show that the simple loop α_s on $\partial B^3 - t(\infty)$ is homotopic to the simple loops of slopes $-s$ and $s + 2$ in $B^3 - t(\infty)$

We first show that α_s is homotopic to α_{-s} in $B^3 - t(\infty)$. Let \mathcal{X} be the orientation-reversing involution of (S^2, \mathbf{P}) induced by the reflection $(x, y) \mapsto (x, -y + 1)$ on \mathbb{R}^2 . The fixed point set of \mathcal{X} is the simple loop of slope 0 which is obtained as the image of the line $\mathbb{R} \times \{1/2\}$. The quotient space \mathcal{S}/\mathcal{X} is homeomorphic to a twice punctured disk, which we denote by R . The projection $\mathcal{S} \rightarrow R$ extends to a continuous map $B^3 - t(\infty) \rightarrow R$, which is a homotopy equivalence. Then the two loops α_s and α_{-s} project to the same loop in R and hence they must be homotopic in $B^3 - t(\infty)$.

Next, we show that show that α_s is homotopic to α_{s+2} in $B^3 - t(\infty)$. To this end, consider the Dehn twist of $B^3 - t(\infty)$ along the “meridian disk”, ie, the disk in $B^3 - t(\infty)$ bounded by the simple loop α_∞ . Then it is homotopic to the identity map, and maps α_s to α_{s+2} . Hence α_s is homotopic to α_{s+2} in $B^3 - t(\infty)$. \square

Remark 4.5 Lemma 4.4 is nothing other than a reformulation of (a part of) Theorem 1.2 of Komori and Series [26], which in turn is a correction of Remark 2.5 of Keen–Series [21]. However, we presented a topological proof, for the sake of completeness.

Their theorem actually implies that the converse to the second assertion of the lemma holds. Namely, two simple loops α_s and $\alpha_{s'}$ are homotopic in $B^3 - t(r)$ if and only if they belong to the same orbit of Γ_r . This is also proved by using the fact that $\pi_1(B^3 - t(r))$ is the free group of rank 2 generated by the meridian pair.

[Lemma 4.4](#) implies the following consequence for 2-bridge knots.

Proposition 4.6 *For every 2-bridge knot $K(r)$, the following holds. If two elements s and s' of $\widehat{\mathcal{Q}}$ lie in the same $\widehat{\Gamma}_r$ -orbit, then α_s and $\alpha_{s'}$ are homotopic in $S^3 - K(r)$.*

Proof Since $\widehat{\Gamma}_r$ is generated by Γ_∞ and Γ_r , we have only to show the assertion when $s' = A(s)$ for some A in Γ_∞ or Γ_r . If $A \in \Gamma_\infty$, then α_s and $\alpha_{s'}$ are homotopic in $B^3 - t(\infty)$ by [Lemma 4.4](#). Since $G(K(r))$ is a quotient of $\pi_1(B^3 - t(\infty))$, this implies that α_s and $\alpha_{s'}$ are homotopic in $S^3 - K(r)$. Similarly, if $A \in \Gamma_r$, then α_s and $\alpha_{s'}$ are homotopic in $B^3 - t(r)$ by [Lemma 4.4](#). Since $G(K(r))$ is a quotient of $\pi_1(B^3 - t(r))$, this also implies that α_s and $\alpha_{s'}$ are homotopic in $S^3 - K(r)$. This completes the proof of the proposition. \square

Corollary 4.7 *If s belongs to the orbit of ∞ or r by $\widehat{\Gamma}_r$, then α_s is nullhomotopic in $S^3 - K(r)$.*

Proof The loops α_∞ and α_r are nullhomotopic in $B^3 - t(\infty)$ and $B^3 - t(r)$, respectively. Hence both of them are nullhomotopic in $S^3 - K(r)$. Thus we obtain the corollary by [Proposition 4.6](#). \square

We shall discuss more about the corollary in [Section 9](#).

Proof of Theorem 1.1 Suppose \tilde{r} belongs to the orbit of r or ∞ by $\widehat{\Gamma}_r$. Then $\alpha_{\tilde{r}}$ is nullhomotopic in $G(K(r)) = \pi_1(\mathcal{S}) / \langle \langle \alpha_\infty, \alpha_r \rangle \rangle$. Thus the normal closure $\langle \langle \alpha_\infty, \alpha_{\tilde{r}} \rangle \rangle$ in $\pi_1(\mathcal{S})$ is contained in $\langle \langle \alpha_\infty, \alpha_r \rangle \rangle$. Hence the identity map on $\pi_1(\mathcal{S})$ induces an epimorphism from $G(K(\tilde{r})) = \pi_1(\mathcal{S}) / \langle \langle \alpha_\infty, \alpha_{\tilde{r}} \rangle \rangle$ to $G(K(r)) = \pi_1(\mathcal{S}) / \langle \langle \alpha_\infty, \alpha_r \rangle \rangle$. It is obvious that the epimorphism sends the upper meridian pair of $G(K(\tilde{r}))$ to that of $G(K(r))$. This completes the proof of [Theorem 1.1](#). \square

5 Continued fraction expansion of \tilde{r} in $\widehat{\Gamma}_r$ -orbits

In this section, we explain what \tilde{r} and $K(\tilde{r})$ look like when \tilde{r} belongs to the $\widehat{\Gamma}_r$ -orbit of r or ∞ , in [Proposition 5.1](#) and [Proposition 5.2](#). These propositions are substantially equivalent.

For the continued fraction expansion $r = [a_1, a_2, \dots, a_m]$, let \mathbf{a} , \mathbf{a}^{-1} , $\epsilon \mathbf{a}$ and $\epsilon \mathbf{a}^{-1}$, with $\epsilon \in \{-, +\}$, be the finite sequences defined as follows:

$$\begin{aligned} \mathbf{a} &= (a_1, a_2, \dots, a_m), & \mathbf{a}^{-1} &= (a_m, a_{m-1}, \dots, a_1), \\ \epsilon \mathbf{a} &= (\epsilon a_1, \epsilon a_2, \dots, \epsilon a_m), & \epsilon \mathbf{a}^{-1} &= (\epsilon a_m, \epsilon a_{m-1}, \dots, \epsilon a_1). \end{aligned}$$

Then we have the following proposition, which is proved in [Section 5.1](#).

Proposition 5.1 *Let r be as above. Then a rational number \tilde{r} belongs to the orbit of r or ∞ by $\hat{\Gamma}_r$ if and only if \tilde{r} has the following continued fraction expansion:*

$$\tilde{r} = 2c + [\epsilon_1 \mathbf{a}, 2c_1, \epsilon_2 \mathbf{a}^{-1}, 2c_2, \epsilon_3 \mathbf{a}, \dots, 2c_{n-1}, \epsilon_n \mathbf{a}^{(-1)^{n-1}}]$$

for some positive integer n , $c \in \mathbb{Z}$, $(\epsilon_1, \epsilon_2, \dots, \epsilon_n) \in \{-, +\}^n$ and $(c_1, c_2, \dots, c_{n-1}) \in \mathbb{Z}^{n-1}$.

The following proposition is a variation of [Proposition 5.1](#), written in topological words, which is proved in [Section 5.2](#).

Proposition 5.2 *We present the 2-bridge link $K(r)$ by the plat closure*

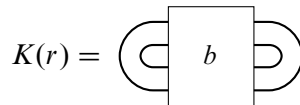

for some 4-braid b . Then \tilde{r} belongs to the $\hat{\Gamma}_r$ -orbit of ∞ or r if and only if $K(\tilde{r})$ is presented by

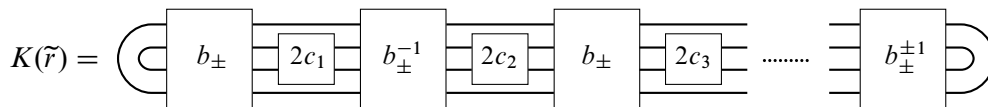

for some signs of b_{\pm} and b_{\pm}^{-1} and for some integers c_i , where a boxed “ $2c_i$ ” implies $2c_i$ half-twists, and $b_{\pm}^{\pm 1}$ are the braids obtained from b by mirror images as shown in the forthcoming [Theorem 6.1](#).

5.1 Continued fraction expansions of \tilde{r} and r

In this section, we prove [Proposition 5.1](#). The proof is based on the correspondence between the modular tessellation and continued fraction expansions (see Hatcher–Thurston [15, p 229 Remark] for this correspondence).

We first recall the correspondence between continued fraction expansions and edge-paths in the modular diagram \mathcal{D} . For the continued fraction expansion $r = [a_1, a_2, \dots, a_m]$,

set $r_{-1} = \infty, r_0 = 0$ and $r_j = [a_1, a_2, \dots, a_j]$ ($1 \leq j \leq m$). Then $(r_{-1}, r_0, r_1, \dots, r_m)$ determines an edge-path in \mathcal{D} , ie, $\langle r_j, r_{j+1} \rangle$ is an edge of \mathcal{D} for each j ($-1 \leq j \leq m - 1$). Moreover, each component a_j of the continued fraction is read from the edge-path by the following rule: The vertex r_{j+1} is the image of r_{j-1} by the parabolic transformation of \mathcal{D} , centered on the vertex r_j , by $(-1)^j a_j$ units in the clockwise direction. (Thus the transformation is conjugate to

$$\begin{pmatrix} 1 & (-1)^{j-1} a_j \\ 0 & 1 \end{pmatrix}$$

in $PSL(2, \mathbb{Z})$.) See Figure 4.

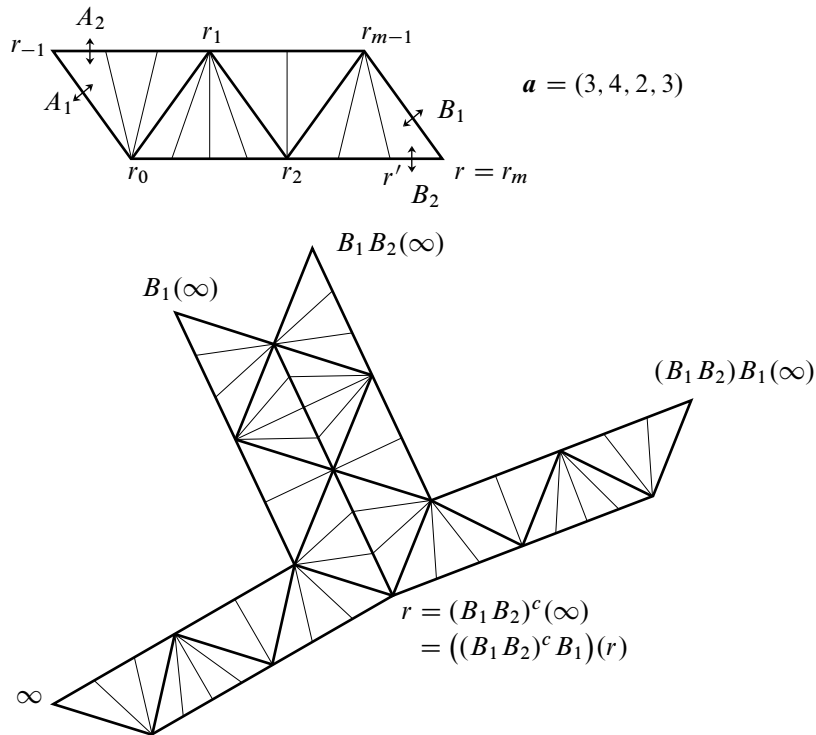

Figure 4: Continued fractions

Conversely, any edge-path $(s_{-1}, s_0, s_1, \dots, s_m)$ in \mathcal{D} with $s_{-1} = \infty$ and $s_0 = 0$ gives rise to a continued fraction expansion $[b_1, b_2, \dots, b_m]$ of the terminal vertex s_m , where b_j is determined by the rule explained in the above. If we drop the condition $s_0 = 0$, then $s_0 \in \mathbb{Z}$ and the edge-path determines the continued fraction expansion of the terminal vertex s_m of the form $s_0 + [b_1, b_2, \dots, b_m]$.

Now recall the fundamental domain for $\widehat{\Gamma}_r$ described in the introduction. It is bounded by the four edges $\langle \infty, 0 \rangle$, $\langle \infty, 1 \rangle$, $\langle r, r_{m-1} \rangle$ and $\langle r, r' \rangle$, where

$$r_{m-1} = [a_1, a_2, \dots, a_{m-1}] \quad \text{and} \quad r' = [a_1, a_2, \dots, a_{m-1}, a_m - 1].$$

Let A_1 , A_2 , B_1 and B_2 , respectively, be the reflections in these edges. Then

$$\begin{aligned} \Gamma_\infty &= \langle A_1 \mid A_1^2 = 1 \rangle * \langle A_2 \mid A_2^2 = 1 \rangle, \\ \Gamma_r &= \langle B_1 \mid B_1^2 = 1 \rangle * \langle B_2 \mid B_2^2 = 1 \rangle. \end{aligned}$$

The product $A_1 A_2$ is the parabolic transformation of \mathcal{D} , centered on the vertex ∞ , by 2 units in the clockwise direction, and it generates the normal infinite cyclic subgroup of Γ_∞ of index 2. Similarly, the product $B_1 B_2$ is the parabolic transformation of \mathcal{D} , centered on the vertex ∞ , by 2 or -2 units in the clockwise direction according as m is even or odd, and it generates the normal infinite cyclic subgroup of Γ_r of index 2.

Pick a nontrivial element, W , of $\widehat{\Gamma}_r = \Gamma_\infty * \Gamma_r$. Then it is expressed uniquely as a reduced word $W_1 W_2 \cdots W_n$ or $W_0 W_1 \cdots W_n$ where W_j is a nontrivial element of the infinite dihedral group Γ_∞ or Γ_r according as j is even or odd. When $W = W_1 W_2 \cdots W_n$, we regard $W = W_0 W_1 \cdots W_n$ with $W_0 = 1$.

Set $\eta_j = +1$ or -1 according as W_j is orientation-preserving or reversing. Then there is a unique integer c_j such that:

- (1) If j is even, then $W_j = (A_1 A_2)^{c_j}$ or $(A_1 A_2)^{c_j} A_1$ according as $\eta_j = +1$ or -1 .
- (2) If j is odd, then $W_j = (B_1 B_2)^{c_j}$ or $(B_1 B_2)^{c_j} B_1$ according as $\eta_j = +1$ or -1 .

Now let \tilde{r} be the image of ∞ or r by W . If n is odd, then $W_n \in \Gamma_r$ and hence $W(r) = W_0 W_1 \cdots W_{n-1}(r)$. Similarly, if n is even, then $W(\infty) = W_0 W_1 \cdots W_{n-1}(\infty)$. So, we may assume $\tilde{r} = W(\infty)$ or $W(r)$ according as n is odd or even.

Lemma 5.3 *Under the above setting, \tilde{r} has the following continued fraction expansion.*

$$\tilde{r} = -2c_0 + [\epsilon_1 \mathbf{a}, 2\epsilon_1 c_1, \epsilon_2 \mathbf{a}^{-1}, 2\epsilon_2 c_2, \dots, 2\epsilon_n c_n, \epsilon_{n+1} \mathbf{a}^{(-1)^n}],$$

where $\epsilon_j = \eta_0(-\eta_1) \cdots (-\eta_{j-1})$.

Proof First, we treat the case when $W_0 = 1$. Recall that r is joined to ∞ by the edge-path $(r_{-1}, r_0, \dots, r_{m-1}, r_m)$. Since W_1 fixes the point $r = r_m$, we can join the above edge-path with its image by W_1 , and obtain the edge path

$$(r_{-1}, r_0, \dots, r_{m-1}, r_m, W_1(r_{m-1}), \dots, W_1(r_0), W_1(r_{-1})).$$

This joins ∞ and $W_1(r_{-1}) = W_1(\infty)$. By applying the correspondence between the edge-paths and the continued fractions, we see that the rational number $W_1(\infty)$ has the continued fraction expansion $[\mathbf{a}, 2c_1, -\eta_1 \mathbf{a}^{-1}]$. This can be confirmed by noticing the following facts (see Figure 4).

- (1) $W_1(r_{m-1})$ is the image of r_{m-1} by the parabolic transformation of \mathcal{D} , centered on the vertex $r_m = W_1(r_m)$, by $(-1)^m 2c_1$ units in the clockwise direction.
- (2) $W_1(r_{j-1})$ is the image of $W_1(r_{j-1})$ by the parabolic transformation of \mathcal{D} , centered on the vertex $W_1(r_j)$, by $(-1)^{j-1} a_j$ or $(-1)^j a_j$ units in the clockwise direction according as W_1 is orientation-preserving or reversing.

By the temporary assumption $W_0 = 1$, we have $\epsilon_1 = \eta_0 = +1$ and $\epsilon_2 = \eta_0(-\eta_1) = -\eta_1$. This proves the lemma when $n = 1$.

Suppose $n \geq 2$. Then, since $W_1 W_2(r_{-1}) = W_1(r_{-1})$, we can join the image of the original edge-path by $W_1 W_2$ to the above edge-path, and obtain an edge-path which joins ∞ to $W_1 W_2(r)$. More generally, by joining the images of the original edge-path by $1, W_1, W_1 W_2, \dots, W_1 W_2 \cdots W_n$, we obtain an edge-path which joins ∞ to \tilde{r} . By using this edge path we obtain the lemma for the case $W_0 = 1$.

Finally, we treat the case when $W_0 \neq 1$. In this case, we consider the edge-path obtained as the image of the above edge-path by W_0 . Since $W_0(\infty) = \infty$, this path joins ∞ to \tilde{r} and the vertex next to ∞ is equal to the integer $-2c_0$. Hence we obtain the full assertion of the lemma. \square

Proof of Proposition 5.1 Immediate from Lemma 5.3. \square

5.2 Presentation of $K(\tilde{r})$

In this section, we give a proof of Proposition 5.2. It is a substantially equivalent proof to the proof of Proposition 5.1 in Section 5.1, but written in other words from the viewpoint of the correspondence between $SL(2, \mathbb{Z})$ and plat closures of 4-braids (see Burde–Zieschang [7, Section 12.A] for this correspondence).

In the proof of Proposition 5.2, we use automorphisms of the modular tessellation \mathcal{D} . Let $\text{Aut}(\mathcal{D})$ denote the group of automorphisms of \mathcal{D} , and let $\text{Aut}^+(\mathcal{D})$ denote its subgroup consisting the orientation-preserving automorphisms. Then

$$\begin{aligned} \text{Aut}^+(\mathcal{D}) &= PSL(2, \mathbb{Z}), \\ \text{Aut}(\mathcal{D}) &= \left\{ A \in GL(2, \mathbb{Z}) \mid \det(A) = \pm 1 \right\} / \left\{ \pm \begin{pmatrix} 1 & 0 \\ 0 & 1 \end{pmatrix} \right\}. \end{aligned}$$

Proof of Proposition 5.2 We give plat presentations of $K(r)$ and $K(\tilde{r})$, and show that they satisfy the proposition.

First, we give a plat presentation of $K(r)$, as follows. By Theorem 3.1, we may assume that $r = \text{odd/even}$ or even/odd . Then we can choose a continued fraction expansion of r with even entries, ie, of the form $[2a_1, 2a_2, \dots, 2a_m]$. Then m is odd if $r = \text{odd/even}$, and m is even if $r = \text{even/odd}$. In the latter case, we replace the continued fraction expansion with $[2a_1, \dots, 2a_{m-1}, 2a_m - 1, 1]$, and set $[a'_1, a'_2, \dots, a'_n]$ to be this continued fraction. Namely, $[a'_1, a'_2, \dots, a'_n]$ is

$$\begin{cases} [2a_1, 2a_2, \dots, 2a_m] & \text{if } m \text{ is odd (ie, if } r = \text{odd/even),} \\ [2a_1, \dots, 2a_{m-1}, 2a_m - 1, 1] & \text{if } m \text{ is even (ie, if } r = \text{even/odd).} \end{cases}$$

Then we have a presentation

$$r = B \cdot \infty, \text{ where } B = \begin{pmatrix} 1 & 0 \\ a'_1 & 1 \end{pmatrix} \begin{pmatrix} 1 & a'_2 \\ 0 & 1 \end{pmatrix} \begin{pmatrix} 1 & 0 \\ a'_3 & 1 \end{pmatrix} \cdots \begin{pmatrix} 1 & 0 \\ a'_n & 1 \end{pmatrix},$$

recalling that B acts on $\mathbb{Q} \cup \{\infty\}$ by the linear fractional transformation. Further, the 2-bridge link $K(r)$ is given by the plat closure of the braid b corresponding to the matrix B ,

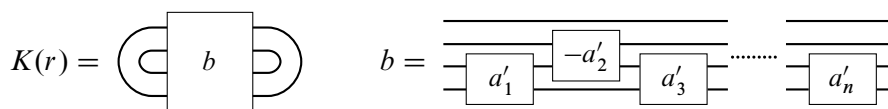

where a boxed “ a'_i ” implies a'_i half-twists.

Next, we give a plat presentation of $K(\tilde{r})$. Since $B \in \text{Aut}(\mathcal{D})$, Γ_r is presented by

$$\Gamma_r = B \Gamma_\infty B^{-1}, \text{ where } \Gamma_\infty = \left\{ \begin{pmatrix} 1 & \text{even} \\ 0 & \pm 1 \end{pmatrix} \right\} \subset \text{Aut}(\mathcal{D}).$$

By definition, \tilde{r} belongs to the orbit of ∞ or $r = B \cdot \infty$ by the action of $\hat{\Gamma}_r$, which is generated by Γ_r and Γ_∞ . Hence, \tilde{r} is equal to the image of ∞ by one of the following

automorphisms of \mathcal{D} :

$$\begin{aligned}
 & B \begin{pmatrix} 1 & \text{even} \\ 0 & \pm 1 \end{pmatrix} B^{-1} \begin{pmatrix} 1 & \text{even} \\ 0 & \pm 1 \end{pmatrix} \cdots B \begin{pmatrix} 1 & \text{even} \\ 0 & \pm 1 \end{pmatrix} B^{-1}, \\
 & \begin{pmatrix} 1 & \text{even} \\ 0 & \pm 1 \end{pmatrix} B \begin{pmatrix} 1 & \text{even} \\ 0 & \pm 1 \end{pmatrix} B^{-1} \begin{pmatrix} 1 & \text{even} \\ 0 & \pm 1 \end{pmatrix} \cdots B \begin{pmatrix} 1 & \text{even} \\ 0 & \pm 1 \end{pmatrix} B^{-1}, \\
 & B \begin{pmatrix} 1 & \text{even} \\ 0 & \pm 1 \end{pmatrix} B^{-1} \begin{pmatrix} 1 & \text{even} \\ 0 & \pm 1 \end{pmatrix} \cdots B^{-1} \begin{pmatrix} 1 & \text{even} \\ 0 & \pm 1 \end{pmatrix} B, \\
 & \begin{pmatrix} 1 & \text{even} \\ 0 & \pm 1 \end{pmatrix} B \begin{pmatrix} 1 & \text{even} \\ 0 & \pm 1 \end{pmatrix} B^{-1} \begin{pmatrix} 1 & \text{even} \\ 0 & \pm 1 \end{pmatrix} \cdots B^{-1} \begin{pmatrix} 1 & \text{even} \\ 0 & \pm 1 \end{pmatrix} B.
 \end{aligned}$$

By using

$$\begin{aligned}
 B_+ & := B, \\
 B_- & := \begin{pmatrix} 1 & 0 \\ 0 & -1 \end{pmatrix} B \begin{pmatrix} 1 & 0 \\ 0 & -1 \end{pmatrix} = \begin{pmatrix} 1 & 0 \\ -a'_1 & 1 \end{pmatrix} \begin{pmatrix} 1 & -a'_2 \\ 0 & 1 \end{pmatrix} \cdots \begin{pmatrix} 1 & 0 \\ -a'_n & 1 \end{pmatrix},
 \end{aligned}$$

the above elements have the following unified expression:

$$\begin{pmatrix} 1 & \text{even} \\ 0 & 1 \end{pmatrix} B_{\pm} \begin{pmatrix} 1 & 2c_1 \\ 0 & 1 \end{pmatrix} B_{\pm}^{-1} \begin{pmatrix} 1 & 2c_2 \\ 0 & 1 \end{pmatrix} B_{\pm} \begin{pmatrix} 1 & 2c_3 \\ 0 & 1 \end{pmatrix} \cdots B_{\pm}^{\pm 1}.$$

Hence $K(\tilde{r})$ is given by the plat closure of its corresponding braid,

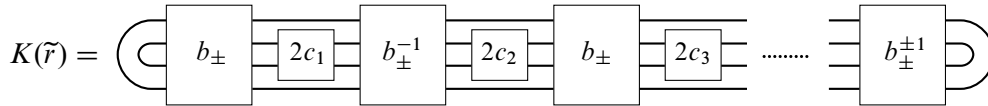

where b_- is the braid corresponding to B_- :

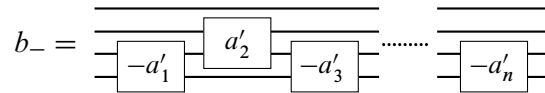

The difference between the presentations of the required $K(\tilde{r})$ of Proposition 5.2 and the above $K(\tilde{r})$ is that b_- of the required $K(\tilde{r})$ is the mirror image of b with respect to (the plane intersecting this paper orthogonally along) the central horizontal line, while b_- of the above $K(\tilde{r})$ is the mirror image of b with respect to this paper. Indeed, they are different as braids, but their plat closures are isotopic, because both of them are isotopic to, say,

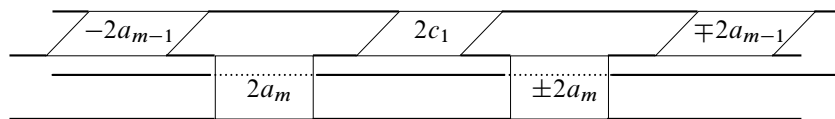

and we can move any full-twists to the opposite side of the square pillar by an isotopy of the plat closure. Here we draw only a part of the braid in the above figure. (See, for example, Siebenmann [39], Burde–Zieschang [7, Figure 12.9(b)] or Kauffman–Lambropoulou [18, Section 2] for an exposition of this flype move.) Hence, the required $K(\tilde{r})$ is isotopic to the above $K(\tilde{r})$, completing the proof of Proposition 5.2. \square

6 Constructing a continuous map $(S^3, K(\tilde{r})) \rightarrow (S^3, K(r))$

In this section, we prove Theorem 6.1 below. As mentioned in the introduction, we obtain Theorem 1.2 from Proposition 5.2 and Theorem 6.1.

Theorem 6.1 *Let K be a 2-bridge link presented by the plat closure of a 4-braid b , and let \tilde{K} be a 2-bridge link of the form*

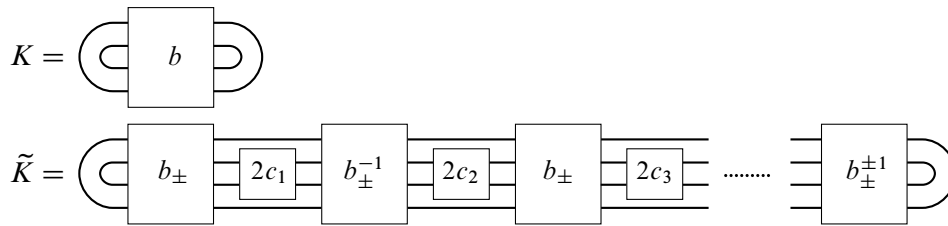

for some signs of b_{\pm} and b_{\pm}^{-1} and for some integers c_i , where a boxed “ $2c_i$ ” implies $2c_i$ half-twists, and $b_{\pm}^{\pm 1}$ are the braids obtained from b by mirror images in the following fashion.

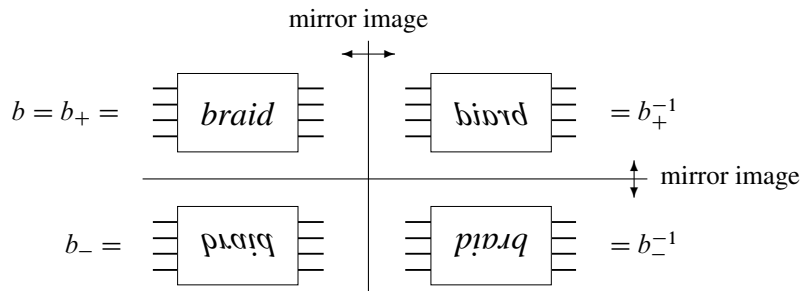

Then there is a proper branched fold map $f: (S^3, \tilde{K}) \rightarrow (S^3, K)$ which respects the bridge structures and induces an epimorphism $G(\tilde{K}) \rightarrow G(K)$

Proof To construct the map f , we partition (S^3, K) and (S^3, \tilde{K}) into B^3 's and $(S^2 \times I)$'s as below, where I denotes an interval, and we call a piece of the partition of

(S^3, \tilde{K}) including $b_{\pm}^{\pm 1}$ (resp. $2c_i$ half-twisted strings) a b -domain (resp. c -domain).

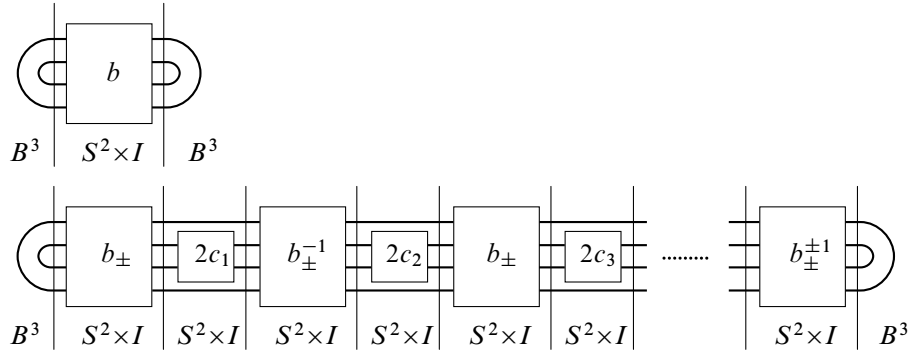

We successively construct the map f , first on a b -domain, secondly on a c -domain, and thirdly on B^3 's, so that the required map is obtained by gluing them together.

First, we construct f on each b -domain by mapping $(S^2 \times I, b_{\pm}^{\pm 1})$ to $(S^2 \times I, b)$ according to the definition of $b_{\pm}^{\pm 1}$. To be precise, after the natural identification of the b -domain and the middle piece of (S^3, K) with $S^2 \times I$, the homeomorphism is given by the following self-homeomorphism on $S^2 \times I$.

- (1) If the associated symbol is b_{+}^{+1} , the homeomorphism is $\text{id} \times \text{id}$.
- (2) If the associated symbol is b_{-}^{+1} , the homeomorphism is $R_1 \times \text{id}$, where R_1 is the homeomorphism of S^2 induced by (the restriction to a level plane of) the reflection of \mathbb{R}^3 in the vertical plane which intersects this paper orthogonally along the central horizontal line.
- (3) If the associated symbol is b_{+}^{-1} , the homeomorphism is $\text{id} \times R_2$, where R_2 is the homeomorphism of $[-1, 1]$ defined by $R_2(x) = -x$.
- (4) If the associated symbol is b_{-}^{-1} , the homeomorphism is $R_1 \times R_2$.

Secondly, we construct the restriction of f to each c -domain. To this end, note that the two b -domains adjacent to a c -domain are related either by a π -rotation (about the vertical axis in the center of the c -domain) or by a mirror reflection (along the central level 2-sphere in the c -domain). This follows from the following facts.

- (1) The upper suffixes of the symbols associated with the b -regions are $+1$ and -1 alternatively.
- (2) b_{ϵ}^{+1} and b_{ϵ}^{-1} are related by a mirror reflection for each sign ϵ .
- (3) b_{ϵ}^{+1} and $b_{-\epsilon}^{-1}$ are related by a π -rotation for each sign ϵ .

The restriction of f to a c -domain is constructed as follows. If the two relevant b -domains are related by a π -rotation, then f maps the c -domain to the left or right domain of (S^3, K) as illustrated in Figure 5. If the two relevant b -domains are related by a mirror reflection, then f maps the c -domain to the left or right domain of (S^3, K) as illustrated in Figure 6. In either case, the map can be made consistent with the maps from the b -domains constructed in the first step. Moreover, it is a branched fold map and “respects the bridge structures”. In fact, in the first case, it has a single branch line in the central level 2-sphere, whereas in the latter case, it has two branch lines lying in level 2-spheres and a single fold surface, which is actually the central level 2-sphere.

Thirdly, the restriction of f either to the first left or to the first right domains of (S^3, \tilde{K}) is defined to be the natural homeomorphism to the left or the right domain of (S^3, K) which extends the map already defined on its boundary.

By gluing the maps defined on the pieces of (S^3, \tilde{K}) , we obtain the desired branched fold map $f: (S^3, \tilde{K}) \rightarrow (S^3, K)$ which respect the bridge structures. The induced homomorphism $f_*: G(\tilde{K}) \rightarrow G(K)$ maps the upper meridian pair of $G(\tilde{K})$ to that of $G(K)$ and hence it is surjective. \square

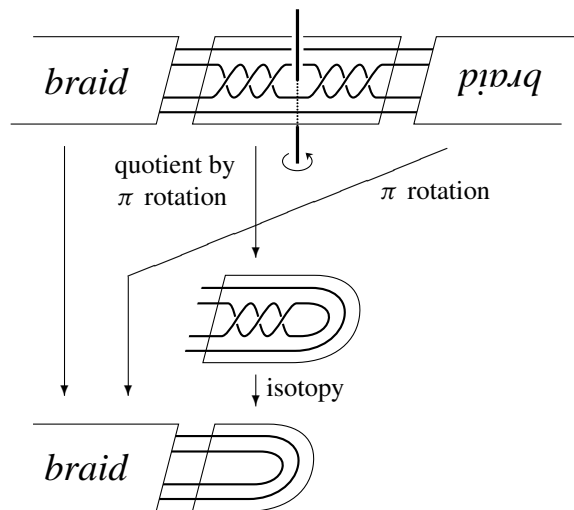

Figure 5: Construction of the map f on a c -domain, when the two adjacent b -domains are related by a π -rotation

At the end of this section, we present further properties of the map f we have constructed.

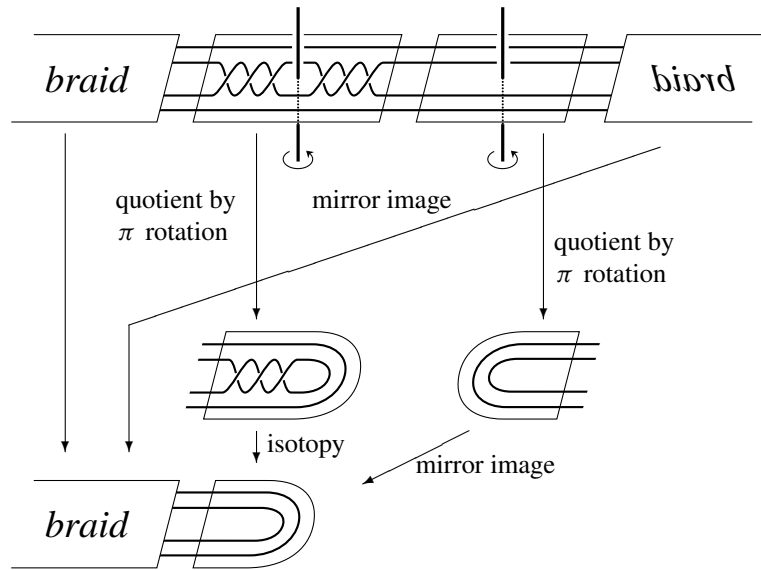

Figure 6: Construction of the map f on a c -domain, when two adjacent b -domains are related by a mirror reflection

Proposition 6.2 The map $f: (S^3, K(\tilde{r})) \rightarrow (S^3, K(r))$ of Theorem 6.1 satisfies the following properties.

- (1) f sends the upper meridian pair of $K(\tilde{r})$ to that of $K(r)$.
- (2) The degree of f is equal to $d := \sum_j \delta_j \epsilon_j$, where ϵ_j and δ_j are the signs such that the j -th b -domain of \tilde{K} corresponds to $b_{\epsilon_j}^{\delta_j}$.
- (3) The image of the longitude(s) of $K(\tilde{r})$ by $f_*: G(K(\tilde{r})) \rightarrow G(K(r))$ is as follows.
 - (a) If both $K(r)$ and $K(\tilde{r})$ are knots, then $f_*(\tilde{\lambda}) = \lambda^d$.
 - (b) If $K(r)$ is a knot and $K(\tilde{r})$ is a 2-component link $\tilde{K}_1 \cup \tilde{K}_2$. Then $f_*(\tilde{\lambda}_j) = \lambda^{d/2} \mu^{\text{lk}(\tilde{K}_1, \tilde{K}_2)}$ for each $j \in \{1, 2\}$.
 - (c) If $K(r)$ is a 2-component link $K_1 \cup K_2$, then $K(\tilde{r})$ is also a 2-component link and $f_*(\tilde{\lambda}_j) = \lambda_j^d$ for $j \in \{1, 2\}$.

Here λ (resp. λ_j , $\tilde{\lambda}$, $\tilde{\lambda}_j$) denotes the longitude of the knot K (resp. the j -th component of the 2-component link K , the knot \tilde{K} , the j -th component of the 2-component link \tilde{K}_j). The symbol μ represents the meridian of $K(r)$.

- (4) If $\epsilon_j = +$ for every j , then $f: S^3 \rightarrow S^3$ can be made to be an n -fold branched covering branched over a trivial link of $n - 1$ components which is disjoint from

$K(r)$. If $n = 2$, then it is a cyclic covering. If $n \geq 3$, then it is an irregular dihedral covering.

Proof It is obvious that the map f from (S^3, \tilde{K}) to (S^3, K) constructed in the above satisfies the conditions (1), (2) and (4). (In order for f to satisfy (4), one may need to modify the map f so that the image of the branch lines lie on different level 2-spheres.) Thus we prove that f satisfies the condition (3).

Suppose both K and \tilde{K} are knots. Then the degree of the restriction of f to $K(r)$ is equal to the degree d of $f: S^3 \rightarrow S^3$, and therefore we see $f_*(\tilde{\lambda}) = \lambda^d \mu^c$ for some $c \in \mathbb{Z}$. However, since $[\tilde{\lambda}] = 0$ in $H_1(S^3 - \tilde{K})$, we have $f_*([\tilde{\lambda}]) = 0$ in $H_1(S^3 - K)$, which is the infinite cyclic group generated by $[\mu]$. Hence $c = 0$ and therefore $f_*(\tilde{\lambda}) = \lambda^d$.

Suppose K is a knot and \tilde{K} is 2-component link $\tilde{K}_1 \cup \tilde{K}_2$. Then the degree of the restriction of f to each of the components of \tilde{K} is equal to $d/2$, and therefore we see $f_*(\tilde{\lambda}_1) = \lambda^{d/2} \mu^c$ for some $c \in \mathbb{Z}$. Then $[\lambda_1] = 0[\mu_1] + \text{lk}(\tilde{K}_1, \tilde{K}_2)[\mu_2]$ in $H_1(S^3 - \tilde{K})$. Since $f_*[\mu_1] = f_*[\mu_2] = [\mu]$ in $H_1(S^3 - K)$, we have $f_*([\lambda_1]) = \text{lk}(\tilde{K}_1, \tilde{K}_2)[\mu]$. Hence we see $c = \text{lk}(\tilde{K}_1, \tilde{K}_2)$ and therefore

$$f_*(\tilde{\lambda}_1) = \lambda^{d/2} \mu^{\text{lk}(\tilde{K}_1, \tilde{K}_2)}.$$

Similarly, $f_*(\tilde{\lambda}_2) = \lambda^{d/2} \mu^{\text{lk}(\tilde{K}_1, \tilde{K}_2)}$. Finally suppose both K and \tilde{K} are 2-component links. Then the degree of the restriction of f to each of the components of \tilde{K} is equal to d , and therefore we see $f_*(\tilde{\lambda}_1) = \lambda_1^d \mu_1^c$ for some $c \in \mathbb{Z}$. Note that f induces a continuous map $S^3 - \tilde{K}_1 \rightarrow S^3 - K_1$ and therefore $[f_*(\tilde{\lambda}_1)] = 0$ in $H_1(S^3 - K_1)$. Thus we have $c = 0$ and therefore $f_*(\tilde{\lambda}_1) = \lambda_1^d$. Similarly, we have $f_*(\tilde{\lambda}_2) = \lambda_2^d$. \square

Remark 6.3 (1) Under the notation in Proposition 5.1, we can see that the degree of f is equal to $\sum_{j=1}^m \epsilon_j$.

(2) Let q' be the integer such that $0 < q' < p$ and $qq' \equiv 1 \pmod{p}$, and set $r' = q'/p \in (0, 1)$. Then there is an orientation-preserving self-homeomorphism of S^3 which sends $K(r)$ to $K(r')$ and interchanges the upper and lower bridges. Thus Theorem 1.2 is valid even if we replace \mathbf{a} with \mathbf{a}^{-1} . The induced epimorphism $f_*: G(K(\tilde{r})) \rightarrow G(K(r))$ for this case send the upper meridian pair of $K(\tilde{r})$ to a lower meridian pair.

7 Application to character varieties

In this section, we give applications of Theorem 1.1 to character varieties of some 2-bridge knots.

Roughly speaking, a character variety is (a component of a closure of) the space of conjugacy classes of irreducible representations of the knot group $G(K)$ to $SL(2, \mathbb{C})$. An explicit definition of the character variety is outlined as follows; for details see Culler–Shalen [10] and Shalen [38]. Let $R(K)$ be the space of all representations of $G(K)$ to $SL(2, \mathbb{C})$, and let $X(K)$ be the image of the map $R(K) \rightarrow \mathbb{C}^N$ taking ρ to $(\text{tr}(\rho(g_1)), \dots, \text{tr}(\rho(g_N)))$ for “sufficiently many” $g_1, \dots, g_N \in G(K)$. Then $X(K)$ is shown to be an algebraic set. We define $X^{\text{irr}}(K)$ to be the Zariski closure of the image in $X(K)$ of the space of the irreducible representations of $G(K)$ to $SL(2, \mathbb{C})$. By a *character variety* of K , we mean an irreducible component of $X^{\text{irr}}(K)$. If $X^{\text{irr}}(K)$ is irreducible, $X^{\text{irr}}(K)$ itself is a variety. In fact this holds for many knots, though in general $X^{\text{irr}}(K)$ is an algebraic set consisting of some irreducible components.

The second author [32; 33] concretely identified $X^{\text{irr}}(K(r))$ of any 2–bridge knot $K(r)$ with an algebraic set in \mathbb{C}^2 determined by a single 2–variable polynomial, by the map $\rho \mapsto (\text{tr}(\rho(\mu_1)), \text{tr}(\rho(\mu_1\mu_2^{-1}))) \in \mathbb{C}^2$ for the (upper or lower) meridian pair $\{\mu_1, \mu_2\}$ of the 2–bridge knot group. Further, the first author [29] classified the ideal points of $X^{\text{irr}}(K(r))$.

If $r = 1/p$ for odd $p \geq 3$, the 2–bridge knot $K(1/p)$ is the $(2, p)$ torus knot, and $X^{\text{irr}}(K(1/p))$ consists of $(p-1)/2$ components of affine curves [32], whose generic representations are faithful (up to the center of the torus knot group). In particular, $X^{\text{irr}}(K(1/p))$ is reducible for $p \geq 5$. Otherwise (ie, if $K(r)$ is not a torus knot), $K(r)$ is a hyperbolic knot, and $X^{\text{irr}}(K)$ has an irreducible component including the faithful (discrete) representation given by the holonomy of the complete hyperbolic structure of the knot complement.

We have the following application of [Theorem 1.1](#) to the reducibility of $X^{\text{irr}}(K)$.

Corollary 7.1 *Let $K(r)$ and $K(\tilde{r})$ be distinct nontrivial 2–bridge knots such that \tilde{r} belongs to the $\hat{\Gamma}_r$ –orbit of r or ∞ . Then $X^{\text{irr}}(K(\tilde{r}))$ is reducible.*

Proof By [Theorem 1.1](#), there is an epimorphism $\varphi: G(K(\tilde{r})) \rightarrow G(K(r))$, and it induces an inclusion $\varphi^*: X^{\text{irr}}(K(r)) \rightarrow X^{\text{irr}}(K(\tilde{r}))$. As mentioned above, any 2–bridge knot group has faithful representations (modulo the center when it is a torus knot group), and hence, $X^{\text{irr}}(K(r))$ is nonempty. Hence the image $\varphi^*(X^{\text{irr}}(K(r)))$ is a nonempty union of the irreducible components of $X^{\text{irr}}(K(\tilde{r}))$, consisting of nonfaithful representations

$$G(K(\tilde{r})) \xrightarrow{\text{nonfaithful}} G(K(r)) \longrightarrow SL(2, \mathbb{C}).$$

On the other hand, $X^{\text{irr}}(K(\tilde{r}))$ has an irreducible component including a faithful representation

$$G(K(\tilde{r})) \xrightarrow{\text{faithful}} SL(2, \mathbb{C}).$$

(modulo the center when it is a torus knot group). This representation is not contained in $\varphi^*(X^{\text{irr}}(K(r)))$, even when $K(\tilde{r})$ is a torus knot. Hence, $X^{\text{irr}}(K(\tilde{r}))$ is reducible, including at least 2 irreducible components. \square

Remark 7.2 For a 2-component 2-bridge link $K(r)$, the second author [33] concretely identifies $X^{\text{irr}}(K(r))$ with a 2-dimensional algebraic set in \mathbb{C}^3 determined by a single 3-variable polynomial, unless $r \in \frac{1}{2}\mathbb{Z} \cup \{\infty\}$ (where $X^{\text{irr}}(K(r))$ is empty). Moreover, it can be shown by a similar proof that Corollary 7.1 also holds for every 2-bridge link, unless $r \in \frac{1}{2}\mathbb{Z} \cup \{\infty\}$.

A similar argument as the above proof is used by Soma [41] to study the epimorphisms among the fundamental groups of hyperbolic manifolds (see Section 8). The proof of following corollary may be regarded as a kind of the inverse to that of his main result in [41].

Corollary 7.3 For any positive integer n , there is a hyperbolic 2-bridge knot $K(r)$, such that $X^{\text{irr}}(K(r))$ has at least n irreducible components.

Proof By Theorem 1.1, we can construct an infinite tower

$$\cdots \rightarrow G(K(r_n)) \rightarrow G(K(r_{n-1})) \rightarrow \cdots \rightarrow G(K(r_2)) \rightarrow G(K(r_1))$$

of epimorphisms among 2-bridge knot groups such that none of the epimorphisms is an isomorphism. Then by the argument in the proof of Corollary 7.1, $X^{\text{irr}}(K(r_n))$ has an irreducible component including a representation

$$G(K(r_n)) \longrightarrow G(K(r_i)) \xrightarrow{\text{faithful}} SL(2, \mathbb{C}),$$

for each $i = 1, 2, \dots, n$. Since these components are distinct, $X^{\text{irr}}(K(r_n))$ has at least n irreducible components. \square

8 Application to π_1 -surjective maps between 3-manifolds

Let M and N be connected closed orientable 3-manifolds. Then a continuous map $f: M \rightarrow N$ is said to be π_1 -surjective if $f_*: \pi_1(M) \rightarrow \pi_1(N)$ is surjective. If the degree d of f is nonzero, then the index $[\pi_1(N) : f_*(\pi_1(M))]$ is a divisor of d . In particular, if the degree of f is 1, then f is π_1 -surjective. Motivated by this fact, Reid-Wang-Zhou [31] proposed various questions, in relation with Simon's problem [22, Problem 1.12] and Rong's problem [22, Problem 3.100]. In this section, we study the following questions proposed in [31].

- (1) (Question 1.5) Let M and N be closed aspherical 3-manifolds such that the rank of $\pi_1(M)$ equals the rank of $\pi_1(N)$. Assume $\phi: \pi_1(M) \rightarrow \pi_1(N)$ is surjective or its image is a subgroup of finite index. Does ϕ determine a map $f: M \rightarrow N$ of nonzero degree?
- (2) (Question 3.1(D)) Are there only finitely many closed orientable 3-manifolds M_i with the same first Betti number, or the same π_1 -rank, as that of a closed orientable 3-manifold M , for which there is an epimorphism $\pi_1(M) \rightarrow \pi_1(M_i)$?

Example 1.4 in [31] presents a closed hyperbolic 3-manifold M with π_1 -rank > 2 (and $b_1(M) > 2$), for which there are infinitely many mutually nonhomeomorphic hyperbolic 3-manifolds M_i with π_1 -rank 2 (and hence $b_1(M_i) \leq 2$), such that there is a π_1 -surjective degree 0 map $M \rightarrow M_i$. This shows that the conditions on the π_1 -ranks (and Betti numbers) in the above questions are indispensable. Moreover, they give the following partial positive answers to the questions for Seifert fibered spaces and non-Haken manifolds.

- (1) Any π_1 -surjective map between closed orientable Seifert fibered spaces with the same π_1 -rank and with orientable base orbifolds is of nonzero degree [31, Theorem 2.1].
- (2) For any non-Haken closed orientable hyperbolic manifold M , there are only finitely many closed orientable hyperbolic 3-manifolds M_i for which there is an epimorphism $\pi_1(M) \rightarrow \pi_1(M_i)$ [31, Theorem 3.6].

González-Acuña and Ramírez have constructed a counter example to the questions where the source manifold is hyperbolic and the target manifolds are Seifert fibered spaces [13, Example 26]. They asked if there is a counter example where the source and target manifolds are hyperbolic manifolds. The following corollary to Theorem 1.2 gives such an example.

Corollary 8.1 *There is a closed orientable hyperbolic Haken 3-manifold M and infinitely many mutually nonhomeomorphic, closed, orientable, hyperbolic 3-manifolds M_i which satisfy the following conditions.*

- (1) *There is a π_1 -surjective degree 0 map $f_i: M \rightarrow M_i$.*
- (2) *The ranks of the fundamental groups of M and M_i are all equal to 2.*

Proof Pick a proper map $f: (S^3, K(\tilde{r})) \rightarrow (S^3, K(r))$ between 2-bridge links satisfying the conditions of Theorem 1.2, such that the degree of f is 0 and $K(\tilde{r})$ is a 2-component link $\tilde{K}_1 \cup \tilde{K}_2$ and $K(r)$ is a knot. Set $q = \text{lk}(\tilde{K}_1, \tilde{K}_2)$. Then,

by [Proposition 6.2](#), f maps the essential simple loop $\tilde{\lambda}_j - q\tilde{\mu}_j$ on $\partial N(\tilde{K}_j)$ to a nullhomotopic loop on $\partial N(K)$. Let M_0 be the manifold obtained by surgery along the link $\tilde{K}_1 \cup \tilde{K}_2$, where 2-handle is attached along the curve $\tilde{\lambda}_j - q\tilde{\mu}_j$ on $\partial N(\tilde{K}_j)$ for each $j = 1, 2$. Then for every manifold $M(s)$ ($s \in \hat{\mathbb{Q}}$), obtained by s -surgery on $K(r)$, the map $f: S^3 - K(\tilde{r}) \rightarrow S^3 - K(r)$ extends to π_1 -surjective map $M_0 \rightarrow M(s)$ of degree 0. On the other hand, we may choose r and \tilde{r} so that M_0 is hyperbolic and that $M(s)$ are hyperbolic with finite exceptions. For example, if $r = [2, 2]$ and $\tilde{r} = [2, 2, 2, -2, -2]$, then $K(r)$ is the (hyperbolic) figure-eight knot and therefore $M(s)$ is hyperbolic with finite exceptions. Moreover we can check by SnapPea [\[44\]](#) that M_0 is hyperbolic. Since M_0 and $M(s)$ are closed hyperbolic manifolds whose fundamental groups are generated by two elements, their π_1 -ranks must be equal to 2. Moreover, M is Haken, because the first Betti number of M is 2 or 1 according as $\text{lk}(\tilde{K}_1, \tilde{K}_2) = 0$ or not. This completes the proof of [Corollary 8.1](#). \square

Remark 8.2 In the above corollary, the first Betti number of M is ≥ 1 , whereas the first Betti numbers of M_i are all equal to 0. This is the same for [\[13, Example 26\]](#). We do not know if there is a counter example to the second question such that the first Betti numbers of M and M_i are all equal.

[Corollary 8.1](#) does not have a counterpart where the condition that the maps are of degree 0 are replaced with the condition that the maps are nonzero degree. In fact, Soma [\[41\]](#) proves that for every closed, connected, orientable 3-manifold M , the number of mutually nonhomeomorphic, orientable, hyperbolic 3-manifolds dominated by M is finite. (Here a 3-manifold N is said to be *dominated* by M if there exists a nonzero degree map $f: M \rightarrow N$.) In Soma's theorem, the condition that the manifolds are orientable is essential. In fact, as is noted in [\[41, Introduction\]](#), some arguments in Boileau-Wang [\[3, Section 3\]](#) implies that there is a nonorientable manifold M which dominates infinitely many mutually nonhomeomorphic 3-manifolds.

We present yet another application of [Theorem 1.2](#) to π_1 -surjective maps. By studying the character varieties, Soma [\[42\]](#) observed that there is no infinite descending tower of π_1 -surjective maps between orientable hyperbolic 3-manifolds, namely, any infinite sequence of π_1 -surjective maps

$$M_0 \rightarrow M_1 \rightarrow \cdots \rightarrow M_i \rightarrow M_{i+1} \rightarrow \cdots$$

between orientable hyperbolic 3-manifolds M_i (possibly of infinite volume) contains an isomorphism. On the other hand, Reid-Wang-Zhou constructed an infinite ascending tower of π_1 -surjective maps of degree > 1 between closed orientable hyperbolic 3-manifolds with the same π_1 -rank [\[31, Example 3.2\]](#). The following corollary to [Theorem 1.2](#) refines their example, by constructing such a tower for degree 1 maps.

Corollary 8.3 *There is an infinite ascending tower of π_1 -surjective maps of degree 1*

$$\cdots \rightarrow M_i \rightarrow M_{i-1} \rightarrow \cdots \rightarrow M_1 \rightarrow M_0$$

between closed (resp. cusped) orientable hyperbolic 3-manifolds which satisfies the following conditions.

- (1) *The ranks of $\pi_1(M_i)$ are all equal to 2.*
- (2) *$H_1(M_i) \cong \mathbb{Z}$ for every i , and each map induces an isomorphism between the homology groups.*

Proof By [Theorem 1.2](#), we can construct an infinite ascending tower

$$\cdots \rightarrow (S^3, K_i) \rightarrow (S^3, K_{i-1}) \rightarrow \cdots \rightarrow (S^3, K_1) \rightarrow (S^3, K_0)$$

of degree 1 proper maps among hyperbolic 2-bridge knots, such that each map induces an epimorphism among the knot groups which is not an isomorphism. By taking the knot complements and induced maps, we obtain a desired tower of cusped hyperbolic manifolds. Now, let M_i be the result of 0-surgery on K_i . Since each map sends the meridian-longitude pair of K_i to that of K_{i-1} , the above tower gives rise to a tower of π_1 -surjective maps of degree 1

$$\cdots \rightarrow M_i \rightarrow M_{i-1} \rightarrow \cdots \rightarrow M_1 \rightarrow M_0.$$

By the classification of exceptional surgeries on hyperbolic 2-bridge knots due to Brittenham–Wu [\[6\]](#) and by the orbifold theorem [\[2; 8\]](#), we can choose K_i so that every M_i is hyperbolic. Thus the above tower satisfies the conditions on the π_1 -rank and the homology. Thus our remaining task is to show that none of the maps is a homotopy equivalence. To this end, we choose K_i so that the genus of K_i is monotone increasing. This can be achieved by starting from the continued fraction consisting of only nonzero even integers, ie, the components of the sequence \mathbf{a} in [Proposition 5.1](#) are all nonzero even integers. (Though it seems that any tower satisfies this condition, it is not totally obvious that this is actually the case.) Then the degree of the Alexander polynomial of K_i is monotone increasing. Since the Alexander polynomial is an invariant of (the homotopy type of) the manifold obtained by 0-surgery, this implies that M_i are mutually non-homotopy equivalent. This completes the proof of [Corollary 8.3](#). \square

We note that if we drop the condition on π_1 -rank, then the existence of such an infinite ascending tower is obvious from Kawauchi's imitation theory [\[20\]](#).

9 Some questions

In this final section, we discuss two questions related to [Theorem 1.1](#) and [Theorem 1.2](#).

Question 9.1 (1) Does the converse to [Theorem 1.1](#) hold? Or more generally, given a 2-bridge link $K(r)$, which 2-bridge link group has an epimorphism onto the link group of $K(r)$?

(2) Does the converse to [Corollary 4.7](#) hold? Namely, is it true that α_s is nullhomotopic in $S^3 - K(r)$ if and only if s belongs to the $\widehat{\Gamma}_r$ -orbit of ∞ or r ?

F González-Acuña and A Ramírez gave a nice partial answer to the first question. They proved that if $r = 1/p$ for some odd integer p , namely $K(r)$ is a 2-bridge torus knot, then the knot group of a 2-bridge knot $K(\tilde{r})$ ($\tilde{r} = \tilde{q}/\tilde{p}$ for some odd integer \tilde{p}) has an epimorphism onto the knot group of the 2-bridge torus knot $K(1/p)$ if and only if \tilde{r} has a continued fraction expansion of the form in [Proposition 5.1](#), namely \tilde{r} is contained in the $\widehat{\Gamma}_r$ -orbit of r or ∞ . (See González-Acuña–Ramírez [[12](#), Theorem 1.2] and [[13](#), Theorem 16]). By the proof of [Theorem 1.1](#), this also implies a partial positive answer to the second question when $r = 1/p$ for some odd integer p .

In [[36](#)], the last author studied the second question, in relation with a possible variation of McShane’s identity [[27](#)] for 2-bridge links, by using Markoff maps, or equivalently, trace functions for “type-preserving” $SL(2, \mathbb{C})$ -representations of the fundamental group of the once-punctured torus. See Bowditch [[5](#)] for the precise definition and detailed study of Markoff maps, and our joint paper [[1](#), Section 5.3] for the relation of Markoff maps and the 2-bridge links. He announced an affirmative answer to the second question for the 2-bridge torus link $K(1/p)$ for every integer p , the figure-eight knot $K(2/5)$ and the 5_1 -knot $K(3/7)$. In his master thesis [[11](#)] supervised by the third author, Tomokazu Eguchi obtained, by numerical calculation of Markoff maps, an affirmative answer to the question for the twist knots $K(n/(2n+1))$ for $2 \leq n \leq 10$.

At the beginning of the introduction, we mentioned the problem: for a given knot K , characterize a knot \tilde{K} which admits an epimorphism $G(\tilde{K}) \rightarrow G(K)$. Motivated by [Theorem 1.2](#), we consider the following procedure to construct knots \tilde{K} from a given knot K .

- (a) Choose a branched fold map $f: M \rightarrow S^3$ for a closed 3-manifold M such that the image of each component of the fold surface is transverse to K and the image of each component of branch curve is a knot disjoint from K . Then we obtain \tilde{K} as the preimage $f^{-1}(K)$.

Such a \tilde{K} often admits an epimorphism $G(\tilde{K}) \rightarrow G(K)$. Further, when we have an epimorphism $\phi: G(\tilde{K}) \rightarrow G(K)$, we consider the following procedures to modify (M, \tilde{K}) .

- (b) Replace (M, \tilde{K}) with the pair obtained from (M, \tilde{K}) by surgery along a simple closed curve in the kernel of ϕ .
- (c) Replace \tilde{K} by the following move.

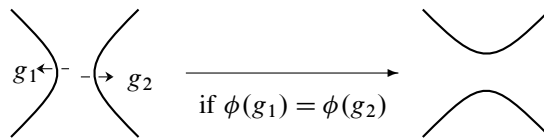

We can construct many examples of \tilde{K} from K by the construction (a), further modifying \tilde{K} by applying (b) and (c) repeatedly. (Even if an intermediate ambient 3-manifold is not S^3 , we may obtain a knot in S^3 by modifying it into S^3 by using (b).) The following question asks whether the constructions (a), (b) and (c) give a topological characterization of a knot \tilde{K} having an epimorphism $G(\tilde{K}) \rightarrow G(K)$ for a given knot K .

Question 9.2 If there is an epimorphism $G(\tilde{K}) \rightarrow G(K)$ between knot groups preserving the peripheral structure, can we obtain \tilde{K} from K by repeatedly applying the above constructions (a), (b) and (c)?

The first author has given a positive answer to this question for all such pairs of prime knots (\tilde{K}, K) with up to 10 crossings, by checking the list in Kitano–Suzuki [23] (see Table 1). The answer to the question is also positive, if either (i) \tilde{K} is a satellite knot with pattern knot K (cf [40, Proposition 3.4]), or (ii) \tilde{K} is a satellite knot of K of degree 1 (ie, \tilde{K} is homologous to K in the tubular neighborhood of K .) In particular, the answer to Question 9.2 is positive, when \tilde{K} is a connected sum of K and some knot. We can also obtain a positive answer for the case when there are a ribbon concordance C from \tilde{K} to K and an epimorphism $G(\tilde{K}) \rightarrow G(K)$ which is compatible with $G(\tilde{K}) \rightarrow \pi_1(S^3 \times I - C) \leftarrow G(K)$ (cf [14, Lemma 3.1]). (In general, a ribbon concordance between knots does not necessarily induce an epimorphism between their knot groups; see [28].)

Finally, we note that certain topological interpretations of some of the epimorphisms in the table of [23] have been obtained by Kitano–Suzuki [24], from a different view point.

| | |
|-------------------------------------------------------------------------------------------|----------------------------------------------------------------------|
| $8_5 \approx 3_1 \# 3_1 \longrightarrow 3_1$ | $10_{85} \approx 3_1 \# 3_1 \longrightarrow 3_1$ |
| $8_{10} \approx 3_1 \# \overline{3_1} \longrightarrow 3_1$ | $10_{87} \approx 3_1 \# \overline{3_1} \longrightarrow 3_1$ |
| $8_{15} \approx 3_1 \# 3_1 \longrightarrow 3_1$ | $10_{98} \approx \approx 3_1 \# 3_1 \longrightarrow 3_1$ |
| $8_{18} \approx 3_1$ | $10_{99} \approx \approx 3_1 \# \overline{3_1} \longrightarrow 3_1$ |
| $8_{19} \approx \overline{3_1} \# \overline{3_1} \longrightarrow \overline{3_1}$ | $10_{103} \sim \sim 3_1$ |
| $8_{20} \approx 3_1 \# \overline{3_1} \longrightarrow 3_1$ | $10_{106} \approx \overline{3_1}$ |
| $8_{21} \approx 3_1 \# 3_1 \longrightarrow 3_1$ | $10_{112} \approx \approx \approx \overline{3_1}$ |
| $9_1 = K([9]) \longrightarrow 3_1$ | $10_{114} \approx \overline{3_1}$ |
| $9_6 = K([6, -2, 3]) \longrightarrow 3_1$ | $10_{139} \approx \approx \overline{3_1}$ |
| $9_{16} \approx \overline{3_1} \# \overline{3_1} \longrightarrow \overline{3_1}$ | $10_{140} \approx \approx 3_1 \# \overline{3_1} \longrightarrow 3_1$ |
| $9_{23} = K([-3, 2, -3, 2, -3]) \longrightarrow 3_1$ | $10_{141} \approx \approx 3_1 \# 3_1 \longrightarrow 3_1$ |
| $9_{24} \approx 3_1 \# \overline{3_1} \longrightarrow 3_1$ | $10_{142} \approx \approx 3_1 \# \overline{3_1} \longrightarrow 3_1$ |
| $9_{28} \approx 3_1 \# 3_1 \longrightarrow 3_1$ | $10_{143} \approx \approx 3_1 \# \overline{3_1} \longrightarrow 3_1$ |
| $9_{40} \longrightarrow 3_1$ | $10_{144} \approx \approx 3_1 \# 3_1 \longrightarrow 3_1$ |
| $10_5 = K([3, -2, 6]) \longrightarrow 3_1$ | $10_{159} \approx \approx 3_1$ |
| $10_9 = K([3, 2, -6]) \longrightarrow 3_1$ | $10_{164} \approx \overline{3_1}$ |
| $10_{32} = K([3, -2, 3, -2, -3]) \longrightarrow 3_1$ | $8_{18} \longrightarrow 4_1$ |
| $10_{40} = K([3, -2, -3, 2, -3]) \longrightarrow 3_1$ | $9_{37} \sim 4_1 \# 4_1 \# 4_1 \longrightarrow 4_1$ |
| $10_{61} \approx \approx \overline{3_1} \# \overline{3_1} \longrightarrow \overline{3_1}$ | $9_{40} \approx 4_1$ |
| $10_{62} \approx \approx 3_1 \# \overline{3_1} \longrightarrow 3_1$ | $10_{58} \approx 4_1 \# 4_1 \longrightarrow 4_1$ |
| $10_{63} \approx \approx 3_1 \# 3_1 \longrightarrow 3_1$ | $10_{59} \approx 4_1 \# 4_1 \longrightarrow 4_1$ |
| $10_{64} \approx \approx \overline{3_1} \# \overline{3_1} \longrightarrow \overline{3_1}$ | $10_{60} \approx 4_1 \# 4_1 \longrightarrow 4_1$ |
| $10_{65} \approx \approx 3_1 \# \overline{3_1} \longrightarrow 3_1$ | $10_{122} \longrightarrow 4_1$ |
| $10_{66} \approx \approx 3_1 \# 3_1 \longrightarrow 3_1$ | $10_{136} \sim 8_6^2 \longrightarrow 4_1$ |
| $10_{76} \approx \overline{3_1} \# \overline{3_1} \longrightarrow \overline{3_1}$ | $10_{137} \approx 4_1 \# 4_1 \longrightarrow 4_1$ |
| $10_{77} \approx 3_1 \# \overline{3_1} \longrightarrow 3_1$ | $10_{138} \approx 4_1 \# 4_1 \longrightarrow 4_1$ |
| $10_{78} \approx 3_1 \# 3_1 \longrightarrow 3_1$ | $10_{74} \sim \sim \overline{5_2}$ |
| $10_{82} \approx 3_1 \# \overline{3_1} \longrightarrow 3_1$ | $10_{120} \longrightarrow 5_2$ |
| $10_{84} \approx 3_1 \# \overline{3_1} \longrightarrow 3_1$ | $10_{122} \approx \overline{5_2}$ |

Table 1: Sketch answer to [Question 9.2](#) for the pairs of prime knots with up to 10 crossings, listed by Kitano-Suzuki [\[23\]](#). Here, we denote the procedures (a), (b), (c) by arrow, “ \approx ”, “ \sim ” respectively, and, say “ $\approx \approx$ ” means to apply (b) twice. The numerical notation for knots and links is the one in Rolfsen [\[35\]](#), and \overline{K} denotes the mirror image of K .

References

- [1] **H Akiyoshi, M Sakuma, M Wada, Y Yamashita**, *Punctured torus groups and 2-bridge knot groups. I*, Lecture Notes in Mathematics 1909, Springer, Berlin (2007) [MR2330319](#)
- [2] **M Boileau, J Porti**, *Geometrization of 3-orbifolds of cyclic type*, Astérisque (2001) 208 [MR1844891](#) Appendix A by Michael Heusener and Porti
- [3] **M Boileau, S Wang**, *Nonzero degree maps and surface bundles over S^1* , J. Differential Geom. 43 (1996) 789–806 [MR1412685](#)
- [4] **M Boileau, S Wang, J Rubinstein**, *Finiteness of 3-manifolds associated with nonzero degree mappings* [arXiv:math.GT/0511541](#)
- [5] **B H Bowditch**, *Markoff triples and quasi-Fuchsian groups*, Proc. London Math. Soc. (3) 77 (1998) 697–736 [MR1643429](#)
- [6] **M Brittenham, Y-Q Wu**, *The classification of exceptional Dehn surgeries on 2-bridge knots*, Comm. Anal. Geom. 9 (2001) 97–113 [MR1807953](#)
- [7] **G Burde, H Zieschang**, *Knots*, de Gruyter Studies in Mathematics 5, Walter de Gruyter & Co., Berlin (1985) [MR808776](#)
- [8] **D Cooper, C D Hodgson, S P Kerckhoff**, *Three-dimensional orbifolds and cone-manifolds*, MSJ Memoirs 5, Mathematical Society of Japan, Tokyo (2000) [MR1778789](#) With a postface by Sadayoshi Kojima
- [9] **R H Crowell, R H Fox**, *Introduction to knot theory*, Graduate Texts in Mathematics 57, Springer, New York (1977) [MR0445489](#) Reprint of the 1963 original
- [10] **M Culler, P B Shalen**, *Varieties of group representations and splittings of 3-manifolds*, Ann. of Math. (2) 117 (1983) 109–146 [MR683804](#)
- [11] **T Eguchi**, *Markoff maps and 2-bridge knot groups (Japanese)*, Master’s thesis, Osaka University (2003)
- [12] **F González-Acuña, A Ramírez**, *Two-bridge knots with property Q* , Q. J. Math. 52 (2001) 447–454 [MR1874490](#)
- [13] **F González-Acuña, A Ramírez**, *Epimorphisms of knot groups onto free products*, Topology 42 (2003) 1205–1227 [MR1981354](#)
- [14] **C M Gordon**, *Ribbon concordance of knots in the 3-sphere*, Math. Ann. 257 (1981) 157–170 [MR634459](#)
- [15] **A Hatcher, W Thurston**, *Incompressible surfaces in 2-bridge knot complements*, Invent. Math. 79 (1985) 225–246 [MR778125](#)
- [16] **J Hempel**, *3-Manifolds*, Ann. of Math. Studies 86, Princeton University Press, Princeton, NJ (1976) [MR0415619](#)
- [17] **T Honma**, *On the 3-dimensional Poincaré conjecture*, Sūgaku 42 (1990) 74–80 [MR1046374](#)

- [18] **L H Kauffman, S Lambropoulou**, *On the classification of rational knots*, Enseign. Math. (2) 49 (2003) 357–410 [MR2028021](#)
- [19] **A Kawauchi**, *A survey of knot theory*, Birkhäuser Verlag, Basel (1996) [MR1417494](#)
Translated and revised from the 1990 Japanese original by the author
- [20] **A Kawauchi**, *Topological imitations*, from: “Lectures at KNOTS ’96 (Tokyo)”, Ser. Knots Everything 15, World Sci. Publ., River Edge, NJ (1997) 19–37 [MR1474517](#)
- [21] **L Keen, C Series**, *The Riley slice of Schottky space*, Proc. London Math. Soc. (3) 69 (1994) 72–90 [MR1272421](#)
- [22] **R Kirby, editor**, *Problems in low-dimensional topology*, from: “Geometric topology (Athens, GA, 1993)”, AMS/IP Stud. Adv. Math. 2, Amer. Math. Soc., Providence, RI (1997) 35–473 [MR1470751](#)
- [23] **T Kitano, M Suzuki**, *A partial order in the knot table*, Experiment. Math. 14 (2005) 385–390 [MR2193401](#)
- [24] **T Kitano, M Suzuki**, *A partial order in the knot table (II)*, preprint (2008)
- [25] **T Kitano, M Suzuki, M Wada**, *Twisted Alexander polynomials and surjectivity of a group homomorphism*, Algebr. Geom. Topol. 5 (2005) 1315–1324 [MR2171811](#)
- [26] **Y Komori, C Series**, *The Riley slice revisited*, from: “The Epstein birthday schrift”, (I Rivin, C Rourke, C Series, editors), Geom. Topol. Monogr. 1 (1998) 303–316 [MR1668296](#)
- [27] **G McShane**, *Simple geodesics and a series constant over Teichmüller space*, Invent. Math. 132 (1998) 607–632 [MR1625712](#)
- [28] **K Miyazaki**, *Ribbon concordance does not imply a degree one map*, Proc. Amer. Math. Soc. 108 (1990) 1055–1058 [MR994781](#)
- [29] **T Ohtsuki**, *Ideal points and incompressible surfaces in two-bridge knot complements*, J. Math. Soc. Japan 46 (1994) 51–87 [MR1248091](#)
- [30] **T Ohtsuki, R Riley**, *Representations of 2-bridge knot groups on 2-bridge knot groups* (1993) unfinished draft
- [31] **A W Reid, S C Wang, Q Zhou**, *Generalized Hopfian property, a minimal Haken manifold, and epimorphisms between 3-manifold groups*, Acta Math. Sin. (Engl. Ser.) 18 (2002) 157–172 [MR1894848](#)
- [32] **R Riley**, *Parabolic representations of knot groups. I*, Proc. London Math. Soc. (3) 24 (1972) 217–242 [MR0300267](#)
- [33] **R Riley**, *Nonabelian representations of 2-bridge knot groups*, Quart. J. Math. Oxford Ser. (2) 35 (1984) 191–208 [MR745421](#)
- [34] **R Riley**, *Algebra for Heckoid groups*, Trans. Amer. Math. Soc. 334 (1992) 389–409 [MR1107029](#)

- [35] **D Rolfsen**, *Knots and links*, Math. Lecture Series 7, Publish or Perish, Berkeley, CA (1976) [MR0515288](#)
- [36] **M Sakuma**, *Variations of McShane's identity for the Riley slice and 2-bridge links*, Sūrikaiseikikenkyūsho Kōkyūroku (1999) 103–108 [MR1744474](#) Hyperbolic spaces and related topics (Japanese) (Kyoto, 1998)
- [37] **H Schubert**, *Knoten mit zwei Brücken*, Math. Z. 65 (1956) 133–170 [MR0082104](#)
- [38] **P B Shalen**, *Representations of 3-manifold groups*, from: “Handbook of geometric topology”, North-Holland, Amsterdam (2002) 955–1044 [MR1886685](#)
- [39] **L Siebenmann**, *Exercices sur les noeuds rationnels* (1972) unpublished
- [40] **D S Silver**, **W Whitten**, *Knot group epimorphisms*, J. Knot Theory Ramifications 15 (2006) 153–166 [MR2207903](#)
- [41] **T Soma**, *Nonzero degree maps to hyperbolic 3-manifolds*, J. Differential Geom. 49 (1998) 517–546 [MR1669645](#)
- [42] **T Soma**, *Epimorphism sequences between hyperbolic 3-manifold groups*, Proc. Amer. Math. Soc. 130 (2002) 1221–1223 [MR1873800](#)
- [43] **S Wang**, *Nonzero degree maps between 3-manifolds*, from: “Proceedings of the International Congress of Mathematicians, Vol. II (Beijing, 2002)”, Higher Ed. Press, Beijing (2002) 457–468 [MR1957056](#)
- [44] **J Weeks**, *SnapPea: a program for creating and studying hyperbolic 3-manifolds* <http://www.geometrygames.org/SnapPea/>

Research Institute for Mathematical Sciences, Kyoto University
Sakyo-ku, Kyoto, 606-8502, Japan

Passed away on March 4, 2000

Department of Mathematics, Graduate School of Science, Hiroshima University
Higashi-Hiroshima, 739-8526, Japan

tomotada@kurims.kyoto-u.ac.jp, sakuma@math.sci.hiroshima-u.ac.jp

<http://www.kurims.kyoto-u.ac.jp/~tomotada/>, <http://www.math.sci.hiroshima-u.ac.jp/~sakuma/>

Received: 30 May 2006 Revised: 15 March 2007