

# Some 3–dimensional transverse $\mathbb{C}$ –links (Constructions of higher-dimensional $\mathbb{C}$ –links, I)

LEE RUDOLPH

By use of a variety of techniques (most based on constructions of quasipositive knots and links, some old and others new), many smooth 3–manifolds are realized as transverse intersections of complex surfaces in  $\mathbb{C}^3$  with strictly pseudoconvex 5–spheres. These manifolds not only inherit interesting intrinsic structures (eg, they have canonical Stein-fillable contact structures), they also have extrinsic structures of a knot-theoretical nature (eg,  $S^3$  arises in infinitely many distinct ways). This survey is not comprehensive; a number of questions are left open for future work.

32Q28, 57M25, 57M27, 57R17; 57Q45, 14B05

## 1 Introduction

A  $k$ –dimensional link in a smooth, oriented  $m$ –manifold  $M$  is a pair  $\mathcal{L} = (L, M)$  where  $L \subset M$  is a compact, non-empty, purely  $k$ –dimensional manifold (without boundary) called the *link-manifold* of  $\mathcal{L}$ ;  $\mathcal{L}$  is *classical* when  $k = 1$ ,  $m = 3$ , and  $M$  is diffeomorphic to  $S^3$ . In case  $L$  is endowed with an extra structure (such as being smooth),  $\mathcal{L}$  is also said to have that structure. A *knot* is a link with connected link-manifold.

For  $n \geq 1$ , let  $\Sigma \subset \mathbb{C}^{n+1}$  be a strictly pseudoconvex  $(2n + 1)$ –sphere,  $\Delta \subset \mathbb{C}^{n+1}$  the closed Stein  $(2n + 2)$ –disk it bounds, and  $U$  an open Stein neighborhood of  $\Delta$  in  $\mathbb{C}^{n+1}$ . If  $f \in \mathcal{O}(U)$  is a non-constant holomorphic function without repeated factors, then  $V(f) := f^{-1}(0)$  is a complex-analytic hypersurface in  $U$ ; up to multiplicities, every complex-analytic hypersurface in  $U$  has the form  $V(f)$ . Let  $L(f, \Sigma) := V(f) \cap \Sigma$ ,  $S(f, \Delta) := V(f) \cap \Delta$ .

**1.1 Definitions** (1) Suppose that the singular set  $\text{Sing}(V(f))$  of  $V(f)$  has empty intersection with  $\Sigma$ , so that  $L(f, \Sigma)$  is the intersection of  $\Sigma$  with the complex  $n$ –manifold  $\text{Reg}(V(f))$  of regular points of  $V(f)$ . If this intersection is transverse, then  $L(f, \Sigma)$  is a smooth compact  $(2n - 1)$ –manifold. In case either

- (a)  $n > 0$  and  $L(f, \Sigma) \neq \emptyset$ , or
- (b)  $n = 0$  (so that necessarily  $L(f, \Sigma) = \emptyset$ ) and  $S(f, \Delta) \neq \emptyset$ ,

call the smooth link  $\mathcal{L}(f, \Sigma) := (L(f, \Sigma), \Sigma)$  a  $(2n - 1)$ -dimensional *transverse  $\mathbb{C}$ -link*.

(2) In case  $L(f, \Sigma)$  is a compact  $(2n - 1)$ -manifold that is *not* smoothly embedded in  $\Sigma$ , call  $\mathcal{L}(f, \Sigma)$  a  $(2n - 1)$ -dimensional *wild  $\mathbb{C}$ -link*.

**1.2 Remarks** (1) The term “ $\mathbb{C}$ -link” was introduced (Rudolph [80]) as a way to include under one name two types of classical links which share the defining feature that, up to ambient isotopy, they arise as intersections of a complex plane curve  $V \subset \mathbb{C}^2$  with a 3-sphere  $\Sigma \subset \mathbb{C}^2$ . One of these types is the special case in that dimension of transverse  $\mathbb{C}$ -links. The other type, “totally tangential  $\mathbb{C}$ -links”, also can be generalized to higher dimensions but will be left undefined here (and will be ignored except in a small neighborhood of [Question 1.8](#)). There are no 1-dimensional wild  $\mathbb{C}$ -links.

(2) For  $q \geq 1$ , let  $f_q: \mathbb{C} \rightarrow \mathbb{C}$ ,  $z \mapsto z^q$ . The empty  $(-1)$ -dimensional  $\mathbb{C}$ -link  $\mathcal{L}(f_q, S^1) = (\emptyset, S^1) =: [q]$  is endowed with an extra structure — namely, the degree- $q$  fibration  $f_q|_{S^1}: S^1 \rightarrow S^1$  — that makes  $[q]$  a degenerate but very useful *fibered link* as defined and discussed in [Section 2.1.3](#). The links and notation  $[q]$  were introduced by Kauffman and Neumann [45] for an application to be used in [Section 3.3](#).

In this paper I launch investigations into 3-dimensional transverse  $\mathbb{C}$ -links (remarks on wild  $\mathbb{C}$ -links in odd dimensions greater than or equal to three are in preparation). I describe in more or less detail several constructions of such links and a few of their interesting properties; deeper investigations are deferred to a later date. Most of the new 3-dimensional constructions rely, in turn, on various constructions of 1-dimensional transverse  $\mathbb{C}$ -links; some of them are new, and presented with proofs or proof sketches, and others simply restated (with references to published proofs) as needed.

One important special case of 3-dimensional transverse  $\mathbb{C}$ -links is well known and well understood. Let  $U$  be a neighborhood of  $\mathbf{z} \in \mathbb{C}^3$ ,  $f \in \mathcal{O}(U)$ . If  $\mathbf{z}$  is an isolated singular point (or a regular point) of  $V(f)$ , then for all sufficiently small  $\varepsilon > 0$  the (round) 5-sphere  $\Sigma = S^5(\mathbf{z}, \varepsilon)$  intersects  $\text{Reg}(V(f))$  transversely. The ambient isotopy type of the transverse 3-dimensional  $\mathbb{C}$ -link  $\mathcal{L}(f, \Sigma)$  is independent of  $\varepsilon$ ; any representative of this ambient isotopy type is called the *link of the isolated singular point of  $f$  at  $\mathbf{z}$* , and may be denoted  $\mathcal{L}_{\mathbf{z}}(f) = (L(f, \mathbf{z}), S^5)$ . Milnor [52] began the systematic knot-theoretical study of these links (and their analogues in higher dimensions; classical knot theory had been applied to singular points of complex plane curves since Brauer [13]), and there is now a huge body of research on the topology (and geometry) both of their link-manifolds and of the embeddings of those link-manifolds in their ambient 5-spheres.

A second special case of 3–dimensional transverse  $\mathbb{C}$ –links (and their analogues in other dimensions, including the classical) has also been studied, though less thoroughly. If  $f \in \mathbb{C}(\mathbb{C}^3)$  is a complex polynomial function and  $V(f)$  is a finite set, then for all sufficiently small  $\varepsilon > 0$  the (round) 5–sphere  $\Sigma = S^5(\mathbf{0}, 1/\varepsilon)$  intersects  $\text{Reg}(V(f))$  transversely. The ambient isotopy type of the transverse 3–dimensional  $\mathbb{C}$ –link  $\mathcal{L}(f, \Sigma)$  is independent of  $\varepsilon$ ; any representative of this ambient isotopy type is called the *link at infinity* of  $f$ , and may be denoted  $\mathcal{L}_\infty(f) = (L(f, \infty), S^5)$ . The link at infinity of a complex algebraic plane curve was introduced under that name by Rudolph [66], though implicit earlier in Chisini [15; 16]; links at infinity of complex algebraic hypersurfaces in all dimensions were introduced by Neumann and Rudolph [59; 60]. See Rudolph [80] for further references.

Aside from those two special cases, very little is known (or has been published) about 3–dimensional transverse  $\mathbb{C}$ –links. This contrasts considerably with the situation for 1–dimensional transverse  $\mathbb{C}$ –links, where — by taking Boileau and Orevkov [9] (applying Eliashberg [19]) and Rudolph [67] together — such links are known to be (up to ambient isotopy) precisely the *quasipositive links*. This characterization is not effective, in the sense that no algorithm is presently known to determine whether or not a given smooth, oriented classical link is quasipositive (precisely: the class of quasipositive links is recursive, but is not known to be recursively enumerable). However, there is an abundance of ways to construct quasipositive links with various prescribed properties, as can be seen in the next part of this paper.

It is not clear whether or to what extent the notion of “quasipositive link” has useful generalizations in higher dimensions, much less whether for some such generalization(s) there exist analogues of [67] and [9] that could lead to a topological characterization of higher-dimensional transverse  $\mathbb{C}$ –links. Even for specifically 3–dimensional transverse  $\mathbb{C}$ –links, this may be a daunting task. For the purposes of the following brief and speculative discussion, definitions of terminology not already introduced can be found in the preliminaries; see Section 2.1.

First note that in the case of a 1–dimensional transverse  $\mathbb{C}$ –link  $\mathcal{L}(f, \Sigma)$  (assuming it to be generic, ie such that  $V(f) \cap \Delta$  is non-singular) there is nothing special about the intrinsic topology of  $L(f, \Sigma)$  or  $S(f, \Delta)$ : any non-empty compact oriented 1–manifold without boundary occurs as  $L(f, S^3)$ , and any compact oriented 2–manifold without closed components appears as  $S(f, D^4)$ , for some  $\mathcal{L}(f, D^4)$ . This contrasts with the situation for 3–dimensional transverse  $\mathbb{C}$ –links in a strictly pseudoconvex 6–disk  $\Delta$ : if  $\mathcal{L}(f, \Delta)$  is generic, then  $S(f, \Delta)$  is a compact Stein manifold-with-boundary bounded by  $L(f, \Sigma)$ , and both kinds of spaces are subject to non-trivial topological restrictions. By [9], an intrinsic topological restriction on  $S(f, \Delta)$  (due to

Loi and Piergallini [50], with later proofs by Akbulut and Ozbagci [1] and Giroux [32] can be restated thus.

**1.3 Theorem** *A compact, oriented, smooth 4–manifold-with-boundary  $W$  is diffeomorphic to a compact Stein surface if and only if  $W$  is a branched covering of  $D^4$  over the  $\mathbb{C}$ –span  $S(f, D^4)$  of a 1–dimensional transverse  $\mathbb{C}$ –link  $\mathcal{L}(f, S^3)$ .*

As noted by Etnyre [23], it is a corollary to Loi and Piergallini’s [Theorem 1.3](#) that the intrinsic topology of  $L(f, \Sigma)$  is restricted as follows.

**1.4 Corollary** *A compact, oriented 3–manifold  $M$  is diffeomorphic to the (strictly pseudoconvex) boundary of a compact Stein surface if and only if there exists an open book  $\mathbf{b}: M \rightarrow \mathbb{C}$  which is positive in the sense that its geometric monodromy  $F_0(\mathbf{b}) \rightarrow F_0(\mathbf{b})$  (where  $F_0(\mathbf{b}) := \mathbf{b}^{-1}([0, \infty])$ , the “first page” of  $\mathbf{b}$ , is a compact oriented 2–manifold-with-boundary) can be written as a product of positive Dehn twists on  $F_0(\mathbf{b})$ .*

Moreover,  $W$  can be reconstructed from its boundary  $M$  together with such a positive factorization of the monodromy of an open book on  $M$  (different open books, or even different factorizations, may give different 4–manifolds  $W$ ).

However, neither of these necessary conditions on  $W$  and  $M = \partial W$  is sufficient to ensure that they actually occur as  $S(f, \Delta)$  or  $L(f, \Sigma)$ . In fact, although every Stein surface embeds properly and holomorphically in  $\mathbb{C}^4$  (Eliashberg and Gromov [22], Schürmann [84; 85]), there are compact Stein surfaces that do not embed holomorphically in  $\mathbb{C}^3$  (indeed, whose underlying differentiable manifolds do not embed smoothly in  $\mathbb{R}^6$ ; Forster [25]). Suppose, however, that  $W$  is in fact a compact Stein surface embedded holomorphically (with strictly pseudoconvex boundary) in  $\mathbb{C}^3$ . In this case, it is easy (possibly after slightly perturbing the complex structure) actually to embed  $W$  as a Stein domain on a (non-singular) complex algebraic surface in  $V(f) \subset \mathbb{C}^3$ ; but it is not immediately obvious that this can be done in such a way that  $W = S(f, \Delta)$  for some strictly pseudoconvex 6–disk  $\Delta$  in  $\mathbb{C}^3$ .

**1.5 Questions** (1) What are necessary and/or sufficient conditions on a compact, oriented, smooth 4–manifold with boundary that it be diffeomorphic to a compact Stein surface embedded holomorphically (with strictly pseudoconvex boundary) in  $\mathbb{C}^3$ ?

(2) What are necessary and/or sufficient conditions on a compact Stein surface embedded holomorphically (with strictly pseudoconvex boundary) in  $\mathbb{C}^3$  that it be  $S(f, \Delta)$  for some strictly pseudoconvex 6–disk  $\Delta \subset \mathbb{C}^3$ ?

The extreme (not to say pathological) behavior exhibited by Stein domains in  $\mathbb{C}^2$ , as demonstrated by Gompf [35], suggests that any full answer to these questions may be quite alarming.

Conceivably the following question can be more easily answered.

**1.6 Question** What are necessary and/or sufficient conditions on a compact, oriented 3–manifold  $M$  that it support some positive open book  $\mathbf{b}: M \rightarrow \mathbb{C}$  that is associated to a realization of  $M$  as a link-manifold  $L(f, \Sigma)$ ?

Another question, presumably easier than characterizing all 3–dimensional transverse  $\mathbb{C}$ –links (whether or not by generalizing quasipositive links), is the following.

**1.7 Question** Can some non-trivial family of 3–dimensional  $\mathbb{C}$ –links be characterized by a reasonable generalization of the notion of a strongly quasipositive link (see [Definitions 2.4](#))?

At a minimum, such a generalization would presumably involve finding properties — including, but going further than, the topological condition in [Theorem 1.3](#) — that a 4–dimensional submanifold-with-boundary  $W$  of a strictly pseudoconvex 5–sphere  $\Sigma = \partial \Delta \subset \mathbb{C}^3$  must possess for there to be an ambient isotopy carrying some 3–dimensional transverse  $\mathbb{C}$ –link  $\mathcal{L}(f, \Sigma)$  onto  $(\partial W, \Sigma)$  and  $(S(f, \Delta), \Delta)$  onto  $(W', \Delta)$ , where  $W'$  is obtained from  $W$  by leaving  $\partial W$  fixed and pushing  $\text{Int } W$  into  $\text{Int } \Delta$ .

[Question 1.7](#) can be made more particular yet. The family of strongly quasipositive 2–component links  $\mathcal{L}(f, S^3)$  such that  $S(f, D^4)$  is an annulus can be characterized as those that can be obtained (via a digression into 1–dimensional totally tangential  $\mathbb{C}$ –links, Rudolph [73; 74; 76]) using a real-analytic Legendrian simple closed curve in  $S^3$  (with its standard contact structure) and its canonical framing; see [Theorem 2.14\(1\)](#).

**1.8 Question** Is there a reasonable generalization of strongly quasipositive annuli?

It is easy to construct totally tangential 2–dimensional  $\mathbb{C}$ –links in  $S^5$  — which are, in particular, Legendrian manifolds — diffeomorphic to  $S^2$  and  $S^1 \times S^1$ ; and these do give 3–dimensional transverse  $\mathbb{C}$ –links (with link-manifolds  $S^2 \times S^1$  and  $(S^1)^3$ , respectively, for the examples I have in mind). It may well be possible, if not easy, to do the same for 2–manifolds  $F_g$  of genus  $g > 1$ ; a careful reading of Haskins and Kapouleas [39] might even provide an appropriate reader (which I am not) with the affirmative answer.

**1.9 Remark** A recent theorem of Kasuya [43] implies that if  $\mathcal{L}(f, \Sigma)$  is a 3–dimensional  $\mathbb{C}$ –link then the first Chern class of its link-manifold  $L(f, \Sigma)$  vanishes.

## 2 Old and new constructions of quasipositive links

This part of the paper assembles constructions of quasipositive links used in the next part to construct 3–dimensional  $\mathbb{C}$ –links. For further information, particularly about constructions not flagged as either new or incorporating new details; see [80] and sources cited there.

### 2.1 Preliminaries on braids, plumbing, trees, fibered links, etc

For general material on braids and closed braids (as well as plats, used in passing in Section 2.7.2); see Birman [6] or Birman and Brendle [7]. For details and further references on braided surfaces, quasipositive braids, etc, see [80].

For an historical survey of open books, see Winkelkemper [95]. For details and further references on contact structures, fibered links, and open books in dimension 3, see Etnyre [24] or Geiges [30].

The first four sections of Ozbagci and Popescu-Pampu [64] form an excellent historical survey of plumbing and many of its generalizations. Starting from first principles, Bonahon and Siebenmann [12, Chapter 12] give a careful treatment of — and calculus for — a particular case (called strip-plumbing below in Remarks 2.3 and Definitions 2.4) that explicitly allows non-orientable plumbands and is often suppressed in or excluded from such discussions.

**2.1.1 Braids and braided surfaces** Let  $n \geq 1$ . The  $n$ –string braid group  $B_n$  with identity  $o^{(n)}$ , standard generators  $\sigma_1, \dots, \sigma_{n-1}$ , and standard presentation

$$\left\langle \sigma_1, \dots, \sigma_{n-1} \mid \begin{array}{l} \sigma_i \sigma_j \sigma_i^{-1} \sigma_j^{-1} = o^{(n)}, \quad 1 \leq i < j - 1 \leq n - 1 \\ \sigma_i \sigma_{i+1} \sigma_i \sigma_{i+1}^{-1} \sigma_i^{-1} \sigma_{i+1}^{-1} = o^{(n)}, \quad 1 \leq i \leq n - 2 \end{array} \right\rangle$$

is identified to the fundamental group of the configuration space

$$\begin{aligned} E_n &:= \{ \{w_1, \dots, w_n\} \subset \mathbb{C} : w_i \neq w_j, 1 \leq i < j \leq n \} \\ &\subset \{ \{w_1, \dots, w_n\} \subset \mathbb{C} \} \cong \mathbb{C}^n / \mathfrak{S}_n \end{aligned}$$

with respect to an arbitrary choice of base point  $\omega = \{w_1, \dots, w_n\} \in E_n$ . A *positive band* in  $B_n$  is any member of the conjugacy class of the standard generators; this conjugacy class is independent of the choice of  $\omega$ ; in  $E_n$  it is represented by any positively oriented meridian of the *discriminant locus* consisting of all multisets  $\{w_1, \dots, w_n\} \subset \mathbb{C}$  with  $w_i = w_j$  for some  $i \neq j$ . For  $\beta, \gamma \in B_n$ , let  ${}^\gamma \beta := \gamma \beta \gamma^{-1}$ ; since any two standard generators  $\sigma_i, \sigma_j$  are conjugate, every positive band has the form  ${}^\gamma \sigma_1$  with  $\gamma \in B_n$ . A braid  $\beta \in B_n$  is *quasipositive* in case it belongs to the

submonoid  $Q_n \subset B_n$  generated by the positive bands (equivalently, normally generated by  $\sigma_1$ ).

The closure (or closed braid) of a braid  $\beta$  is a smooth oriented link  $(\widehat{\beta}, S^3)$ , unique up to ambient isotopy, defined as follows. Let  $\ell_\beta: (S^1, 1) \rightarrow (E_n, \omega)$  be a smooth based loop that represents  $\beta \in B_n$ . The *multigraph*

$$\text{gr}(\ell_\beta) = \{(e^{i\theta}, w) \in S^1 \times \mathbb{C} : w \in \ell_\beta(e^{i\theta})\}$$

is then a naturally oriented smooth compact 1-submanifold of the open solid torus  $S^1 \times \mathbb{C}$  such that  $\text{pr}_1 \upharpoonright \text{gr}(\ell_\beta)$  is a covering map. Embed  $S^1 \times \mathbb{C}$  as the interior of one solid torus of a genus-1 Heegaard splitting of  $S^3 \subset \mathbb{C}^2$ , say by the map

$$(2-1) \quad J: S^1 \times \mathbb{C} \rightarrow S^3 : (e^{i\theta}, w) \mapsto \frac{(e^{i\theta} \sqrt{1 + |w|^2}, w)}{\sqrt{1 + 2|w|^2}},$$

and then define  $\widehat{\beta}$  as the image  $J(\text{gr}(\ell_\beta))$ . An oriented link  $(L, S^3)$  is *quasipositive* in case it is ambient isotopic to the closure  $(\widehat{\beta}, S^3)$  of some quasipositive braid  $\beta$ . A *quasipositive band representation* of a (necessarily quasipositive) braid  $\beta \in B_n$  is a  $k$ -tuple  $\underline{b} = (b(1), \dots, b(k))$  of positive bands in  $B_n$  such that  $\beta = \text{br}(\underline{b}) := b(1) \cdots b(k)$ . The calculus of band representations and *braided Seifert ribbons* in  $D^4$  elaborated by Rudolph [68], coupled with the equivalence [67; 9] between 1-dimensional transverse  $\mathbb{C}$ -links and quasipositive links (mentioned in Section 1), establishes a many-many correspondence between non-singular  $\mathbb{C}$ -spans of 1-dimensional transverse  $\mathbb{C}$ -links in  $S^3$  and quasipositive band representations (on all numbers of strings).

**2.1.2 Annuli, strips, plumbing, and trees** A *Seifert surface* is a compact oriented smooth 2-submanifold-with-boundary  $S \subset S^3$  each component of which has non-empty boundary;  $S$  is called a Seifert surface for (or of) the oriented link  $(\partial S, S^3)$ , and  $(\partial S, S^3)$  is said to have the Seifert surface  $S$ .

Let  $\mathcal{L} = (L, S^3)$  be a smooth classical link. A *framing* of  $\mathcal{L}$  is a locally constant function  $f: L \rightarrow \mathbb{Z}$ ; in case  $\mathcal{L}$  is a knot (ie  $L$  is connected),  $f$  is identified with its only value. An *annular surface*  $\mathcal{A}(\mathcal{L}, f)$  of type  $(\mathcal{L}, f)$  is a Seifert surface in  $S^3$  consisting of pairwise disjoint annuli, each of which contains exactly one component  $K$  of  $L$  as its core 1-sphere, and such that the linking number in  $S^3$  of the two boundary components of that annulus is  $-f(K)$  (in other words, the Seifert matrix of that component is  $[f(K)]$ ). The ambient isotopy type of  $\mathcal{A}(\mathcal{L}, f)$  is independent of the orientation of  $L$ . The annular surface  $\mathcal{A}(\mathbb{O}, -1)$  (where  $\mathbb{O} = (O, S^3)$  denotes a trivial knot) is often called a *positive Hopf band* (and its mirror image  $\mathcal{A}(\mathbb{O}, +1)$  a *negative Hopf band*); to avoid possible (if unlikely) confusion with bands in braid groups, here

I will call  $\mathcal{A}(\mathbb{O}, \mp 1)$  *Hopf annuli* instead (see Section 2.4 for some justification of the sobriquet ‘‘Hopf’’).

Given a manifold  $X$  (not necessarily oriented or orientable), let  $|X|$  denote the underlying unoriented manifold; given a link  $\mathcal{L}(L, M)$  with link-manifold  $L$ , let  $|\mathcal{L}(L, M)|$  denote the unoriented link  $(|L|, M)$  (so  $M$  retains its orientation).

**2.1 Definition** Let  $\mathcal{K} = (K, S^3)$  be a classical knot,  $t \in \mathbb{Z}$ . A *strip of type  $\mathcal{K}$  with  $t$  half-twists* is an unoriented 2-submanifold-with-boundary  $\mathcal{S}(\mathcal{K}, t) \subset S^3$  defined as follows:

- (1) in case  $t$  is even,  $\mathcal{S}(\mathcal{K}, t) = |\mathcal{A}(\mathcal{K}, -t/2)|$ ;
- (2) in case  $t$  is odd,  $\mathcal{S}(\mathcal{K}, t)$  is a smoothly embedded Möbius strip  $S \subset S^3$  containing  $K$  as its core 1-sphere, such if the 1-sphere  $\partial S$  is oriented to be everywhere locally parallel (rather than anti-parallel) to  $K$ , then the linking number in  $S^3$  of  $K$  and  $\partial S$  equals  $t$ .

Clearly up to ambient isotopies  $\mathcal{S}(\mathcal{K}, t)$  determines, and is determined by,  $|\mathcal{K}|$  and  $t$ .

Recall that an arc  $\alpha$  in a manifold with boundary  $X$  is *proper* in case  $\partial\alpha = \alpha \cap \partial X$ .

**2.2 Definition** Let  $2p \geq 2$  be even. Call a compact, smooth 2-submanifold-with-boundary  $F \subset S^3$ , not necessarily oriented or orientable, a *2p-gonal plumbing* of submanifolds-with-boundary  $F_1, F_2 \subset S^3$  *along*  $P$  in case there exists a smoothly embedded 2-sphere  $S^2 \subset S^3$  bounding 3-disks  $D_1^3, D_2^3$  such that

- (1)  $F_i = F \cap D_i^3$  ( $i = 1, 2$ ),
- (2)  $F \cap S^2 = F_1 \cap S^2 = F_2 \cap S^2$  is a 2-disk  $P$  such that  $\partial P$  consists of  $2p$  arcs that are, alternately, proper arcs in  $F_1$  and in  $F_2$ .  $F_1$  and  $F_2$  may be called the *plumbands* of this plumbing;  $P$  is its *plumbing patch*.

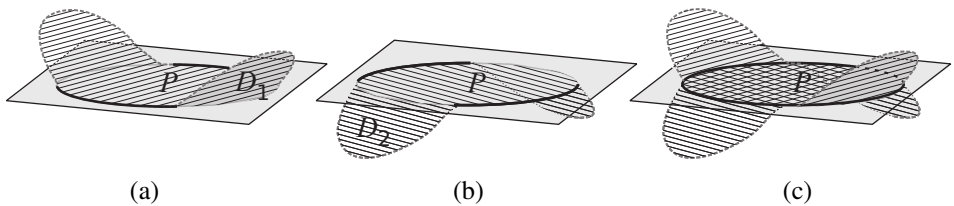

Figure 1: (a) A 2-disk  $D_1 \subset F_1 \subset \mathbb{R}^2 \times [0, \infty[$  intersects  $\mathbb{R}^2 \times \{0\}$  in the round 2-disk  $P$ . (b) A similar 2-disk  $D_2 \subset F_2 \subset \mathbb{R}^2 \times ]-\infty, 0]$ . (c)  $D_1 \cup D_2$  is a 2-disk on  $F = F_1 *_P F_2 \subset \mathbb{R}^3$ .



- 2.3 Remarks** (1) Boundary-connected sum and 2-gonal plumbing are equivalent.
- (2) By *plumbing*, Stallings [89] refers to a construction that, on its face, is a strict generalization of  $2p$ -gonal plumbing; however, as observed in [76, page 260], “it is easy to see that (up to ambient isotopy) every Stallings plumbing is a”  $2p$ -gonal plumbing “of the same plumbands”.
- (3) By his (now standard) coinage *Murasugi sum*, Gabai [27] refers exclusively to  $2p$ -gonal plumbing of Seifert surfaces.
- (4) For Bonahon and Siebenmann [11; 12], the term “plumbing” refers exclusively to 4-gonal plumbing with unoriented (possibly non-orientable) plumbands  $F_i$ .
- (5) As pointed out in [12, Remark 12.3], to stay in the differentiable category when plumbing, care “can easily (and must)” be taken to avoid creating corners (on  $\partial P$ ). Such care is illustrated in Figure 1, where  $S^2 = (\mathbb{R}^2 \times \{0\}) \cup \infty \subset \mathbb{R}^3 \cup \infty = S^3$ ,  $P = \{(x_1, x_2, 0) \in S^2 : x_1^2 + x_2^2 \leq 1\}$ , and liberal use of “bump functions” ensures that when the illustrated 2-disks on  $F_1$  and  $F_2$  are identified along  $P$ ,  $\partial F$  acquires no corners.
- (6) Although in the situation of Definition 2.2 such notations as  $F = F_1 *_P F_2$  or—when  $F$  is being constructed by plumbing, rather than displayed as already plumbed— $F = F_1 P_1 *_P F_2$  are often useful, it is important to note that  $F$  is typically not determined (even up to ambient isotopy) by the pairs  $(F_i, P)$  or  $(F_i, P_i)$  (or their ambient isotopy types): further (combinatorial) information (such as  $n$ -stars and a distinction between the *sides* of  $F_i$  near  $P$ ), sufficient to specify an identification of  $P_1$  and  $P_2$  up to an appropriate equivalence, is required for disambiguation (with a few exceptions); see [12, Remark 12.1] for unoriented plumbands and Rudolph [76] for Murasugi sums.

An especially useful case of plumbing in the sense of [12] is *strip-plumbing*, where  $F_2$  is an unknotted strip  $\mathcal{S}(\mathbb{O}, t) \subset S^3$  and the 4-gonal plumbing patch  $P_2 \subset F_2$  is *core-transverse* in the sense that it is a relative regular neighborhood on  $F_2$  of a *normal arc* (a proper arc that intersects the core 1-sphere  $O \subset F_2$  in a single point, transversely). Iterating strip-plumbing produces several (overlapping) families of unoriented 2-submanifolds-with-boundary of  $S^3$ .

**2.4 Definitions** Let  $F_0 \subset S^3$  be a 2-disk. For  $j = 1, \dots, k$ , let

$$F_{j-1} Q_j *_P \mathcal{S}(\mathbb{O}, t_j) =: F_j$$

be a strip-plumbing.

(1) If all  $Q_i$  are contained in  $F_0$  and all  $t_i$  are even, then  $F_k$  is orientable, and with either orientation it is a *basket* as defined by Rudolph [78] and further studied by Furihata, Hirasawa and Kobayashi [26], Kim, Kwan, and Lee [46], etc.

(2) If all  $|t_i|$  equal 2 (ie all strips are Hopf bands), then again  $F_k$  is orientable, and with either orientation it is a *Hopf-plumbed surface* as studied by Harer [37], Melvin and Morton [51], Rudolph [78], Goodman [36], etc.

(3) Let  $\mathcal{T} = (V(\mathcal{T}), E(\mathcal{T}))$  be a planar tree,  $w: V(\mathcal{T}) \rightarrow \mathbb{Z}$  a weighting of  $\mathcal{T}$ . There seems to be no single standard notation or name for the unoriented, possibly non-orientable 2-submanifold-with-boundary of  $S^3$  associated to  $(\mathcal{T}, w)$  that has been described and constructed by various authors since (at least) Bonahon and Siebenmann [11]; here it will be denoted  $\text{sp}(\mathcal{T}, w)$  and called the *iterated strip-plumbed surface* of the weighted graph (although the strip-plumbing in its construction seems usually to be conceptualized as simultaneous rather than iterated). More precisely, let  $v_1, \dots, v_m$  be an enumeration of the vertices of  $\mathcal{T}$ , and let  $S_i := \mathcal{F}(\mathbb{C}, w(v_i))$ . For each edge  $\{v_i, v_j\}$  of  $\mathcal{T}$ , with  $i < j$ , let  $P_{i,j} \subset S_i, P_{j,i} \subset S_j$  be core-transverse 4-gonal plumbing patches, such that

- (a)  $P_{i,j} \cap P_{k,\ell} = \emptyset$  unless  $(i, j) = (k, \ell)$  and
- (b) for each vertex  $i$  the counter-clockwise cyclic order induced on  $\{j : \{i, j\} \text{ is an edge of } \mathcal{T}\}$  by the hypothesized planar embedding of (the geometric realization of) the planar tree  $\mathcal{T}$  is the same as the cyclic order in which the various plumbing patches  $P_{i,j}$  and  $P_{j,i}$  intersect the core  $S^1$  of  $S_i$ .

Without loss of generality, the enumeration  $v_1, \dots, v_m$  is such that  $v_1, \dots, v_\ell$  are vertices of a subtree of  $\mathcal{T}$  for all  $\ell = 1, \dots, m$ ; in this case, assumptions (a) and (b) above suffice to construct an iterated strip-plumbed 2-manifold-with-boundary

$$(2-2) \quad (\cdots (S_1 \underset{P_{1,2}}{*} \underset{P_{2,1}}{S_2}) \cdots) \underset{P_{q,m}}{*} \underset{P_{m,q}}{S_m} \subset S^3$$

that typically is not unique up to ambient isotopy (see Remark 2.3(6)). However, its boundary is, which excuses the slight abuse of letting  $\text{sp}(\mathcal{T}, w)$  denote any of the surfaces (2-2). An *arborescent link* is an unoriented classical link of the form  $(\partial \text{sp}(\mathcal{T}, w), S^3)$ . For  $\mathcal{T}$  empty, let  $\text{sp}(\mathcal{T}, w) = D^2$ , so that the unoriented trivial knot is arborescent.

**2.1.3 Contact structures, fibered links, and open books** Let  $M$  be a compact, oriented, smooth manifold of odd dimension  $2n + 1 \geq 3$ . A *contact form* on  $M$  is a 1-form  $\alpha$  on  $M$  such that the  $(2n + 1)$ -form  $\alpha \wedge d\alpha \wedge \cdots \wedge d\alpha$  (with  $n$  factors  $d\alpha$ ) is a volume form on  $M$ . A *contact structure* on  $M$  is a field  $\xi$  of  $2n$ -planes on  $M$  of the

form  $\ker(\alpha)$  for some contact form  $\alpha$ . Every strictly pseudoconvex  $(2n + 1)$ -sphere  $\Sigma \subset \mathbb{C}^{n+1}$  (in particular  $S^{2n+1} = S^{2n+1}(\mathbf{0}, 1)$ ) is equipped with a *canonical contact structure*, namely, the field of oriented  $2n$ -planes underlying the field of complex  $n$ -planes tangent to  $\Sigma$ . The link-manifold of any transverse  $\mathbb{C}$ -link (of dimension greater than or equal to 3) has a similarly defined canonical contact structure.

An  $n$ -dimensional smooth link  $\mathcal{L} = (L, M)$  is *Legendrian* for  $\xi$  in case the tangent  $n$ -plane to  $L$  at each of its points lies in the contact  $2n$ -plane of  $M$  at that point. If  $(L, M)$  is Legendrian and  $M$  is Riemannian, then the field of  $n$ -planes on  $L$  complementary in the field of contact  $2n$ -planes to the tangent bundle of  $L$  is a natural normal  $n$ -plane field on  $L$ , independent (up to isotopy) of the metric on  $M$ .

Let  $2n + 1 = 3$ . A contact structure  $\xi$  on  $M$  is called *overtwisted* in case there exists a Legendrian knot  $\mathcal{K} = (K, M)$  such that  $K = \partial D$  where  $D \subset M$  is a smoothly embedded 2-disk such that the restrictions to  $K$  of  $\xi$  and the tangent bundle of  $D$  are homotopic. A contact structure is called *tight* in case it is not overtwisted.

**2.5 Theorem** (Bennequin [5]) *The canonical contact structure  $\xi_0$  on  $S^3$  is tight.*

**2.6 Remark** It follows from a (much) more general theorem of Eliashberg and Gromov [21] that the canonical contact structure on the link-manifold  $L(f, \Sigma)$  of a 3-dimensional transverse  $\mathbb{C}$ -link  $\mathcal{L}(f, \Sigma)$  is tight (because, up to replacing  $f$  by  $f + \varepsilon$ , the  $\mathbb{C}$ -span  $S(f, \Delta)$  is non-singular and thus a *Stein filling* of  $L(f, \Sigma)$ ; see Gompf [34]).

**2.7 Theorem** (Eliashberg [20]) *Overtwisted contact structures are isotopic if and only if they are homotopic as plane fields. Every homotopy class of plane fields on  $S^3$  contains overtwisted contact structures; only the class of  $\xi_0$  contains a tight contact structure.*

If a classical link  $\mathcal{L} = (L, S^3)$  is Legendrian for  $\xi_0$ , then  $\mathcal{L}$  is naturally framed by assigning to each component  $K$  of  $L$  the linking number in  $S^3$  of  $K$  with  $K^+$  obtained by pushing  $K$  a small distance along its natural normal line field. Two standard facts are that every smooth classical link  $\mathcal{L}$  is ambient isotopic to various Legendrian links for  $\xi_0$ , and that if  $\mathcal{L} = \mathcal{K}$  is a knot then there is a finite upper bound—called the *maximal Thurston–Bennequin number* of  $\mathcal{K}$ , and denoted  $TB(\mathcal{K})$ —for the self-linking numbers of Legendrian knots smoothly isotopic to  $\mathcal{K}$ .

Let  $M$  be a smooth, oriented  $m$ -manifold of dimension  $m \geq 2$ . An  $(m - 2)$ -dimensional link  $\mathcal{L} = (L, M)$  is *fibred* in case there is a smooth fibration  $\varphi: M \setminus L \rightarrow S^1$  such that each fiber  $\varphi^{-1}(e^{i\theta}) = \text{Int } F_\theta$  for a smooth, compact  $(m - 1)$ -dimensional

submanifold-with-boundary  $F_\theta \subset M$  with  $\partial F_\theta = L$ ; such an  $F_\theta$  (for any  $L$  and  $\varphi$ ) is a *fiber manifold in  $M$* . The mirror image  $\text{Mir } \mathcal{L} := (L, -M)$  of a link  $\mathcal{L} = (L, M)$  is fibered if and only if  $\mathcal{L}$  is; a connected sum  $\mathcal{L}_1 \# \mathcal{L}_2 := (L_1 \# L_2, M_1 \# M_2)$  of links  $\mathcal{L}_i = (L_i, M_i)$  is fibered if and only if  $\mathcal{L}_1$  and  $\mathcal{L}_2$  are, and similarly for boundary-connected sums of fiber manifolds.

An *open book* on  $M$  is a smooth map  $\mathbf{b}: M \rightarrow \mathbb{C}$  such that  $0 \in \mathbb{C}$  is a regular value of  $\mathbf{b}$  and  $(\mathbf{b}/|\mathbf{b}|) | \mathbf{b}^{-1}(\mathbb{C} \setminus 0): \mathbf{b}^{-1}(\mathbb{C} \setminus 0) \rightarrow S^1$  is a fibration. A *page* of  $\mathbf{b}$  is any one of the smooth, oriented  $(m-1)$ -manifolds-with-boundary  $F_\theta(\mathbf{b}) := \mathbf{b}^{-1}(\{re^{i\theta} : r \geq 0\})$  for  $e^{i\theta} \in S^1$ , with non-empty boundary  $L(\mathbf{b}) := \mathbf{b}^{-1}(0)$ . The oriented link  $\mathcal{L}(\mathbf{b}) := (L(\mathbf{b}), M)$  is the *binding* of  $\mathbf{b}$ . Open books on  $M$  are handy rigidifications of fibered links in  $M$ ; indeed,  $\mathcal{L}(\mathbf{b})$  is a fibered link in  $M$ , every non-empty fibered link in  $M$  is  $\mathcal{L}(\mathbf{b})$  for various open books on  $M$  (all equivalent in an appropriate sense), and every fiber manifold in  $M$  with non-empty boundary is a page of some open book on  $M$  (again, essentially unique). For odd  $m \geq 3$ , an open book on (or fibered link in)  $M$  is called *simple* in case its page (or fiber  $(m-1)$ -manifold) has the homotopy type of a bouquet of  $(m-1)/2$ -spheres; this is always so for  $m = 3$ . For  $m = 3$  and  $M = S^3$ , Neuwirth [62; 63] and Stallings [88] showed independently that a Seifert surface  $F$  is a *fiber surface* (that is, a fiber manifold of dimension 2) if and only if the normal push-off  $F \rightarrow S^3 \setminus F$  induces a homotopy equivalence. It follows that  $F$  is connected ( $H_0(F; \mathbb{Z})$  is Alexander dual to  $H_2(S^3 \setminus F; \mathbb{Z})$ ), and thus that  $\mathcal{A}(\mathcal{L}, f)$  is fibered if and only if  $\mathcal{L} = \mathbb{O}$  and  $f = \pm 1$ .

**2.8 Remark** As noted in the abstract of [76], there is an analogy between fiber surfaces in  $S^3$  and quasipositive Seifert surfaces in  $S^3$ : “A Seifert surface  $S \subset S^3 = \partial D^4$  is a fiber surface if a push-off  $S \rightarrow S^3 \setminus S$  induces a homotopy equivalence; roughly,  $S$  is quasipositive if pushing  $\text{Int } S$  into  $\text{Int } D^4 \subset \mathbb{C}^2$  produces a piece of complex plane curve.” A glimpse of this analogy led me to call the first of my series of papers [69; 70; 72; 73; 76] “Constructions of quasipositive knots and links” in homage to Stallings’s paper “Constructions of fibered knots and links” [89]. Several of the following constructions can be taken as evidence that this analogy is not completely illusory.

## 2.2 Construction: quasipositive satellites (new)

The following construction in classical knot theory is due to Schubert [82].

**2.9 Definition** Let  $\mathcal{K} = (K, S_0^3)$  be a knot,  $\mathcal{L} = (L, S_1^3)$  a link, and  $\mathbb{O} = (O, S_1^3)$  a trivial knot such that

- (a)  $L$  is contained in the interior  $\text{Int } N(O)$  of a regular neighborhood  $N(O)$  of  $O$  in  $S^3$ , and
- (b) no 2-sphere in  $N(O)$  separates any connected component of  $L$  from  $\partial N(O)$ .

Let  $E(K) := S_0^3 \setminus \text{Int } N(K)$  be the exterior of  $K$ , let  $h: \partial E(K) \rightarrow \partial N(O)$  be a faithful diffeomorphism (ie it carries a standard meridian-longitude pair on  $\partial E(K)$  to a standard meridian-longitude pair on  $\partial N(O)$ ), and let  $S^3$  be the (suitably smoothed) identification space  $(E(K) \cup N(O))/\sim$ , where the non-trivial equivalence classes of the equivalence relation  $\sim$  are the pairs  $\{x, h(x)\}$  with  $x \in \partial E(K)$ . Let  $K\{L\}$  denote  $L \subset N(O) \subset S^3$ . In this situation, the link  $\mathcal{K}\{\mathcal{L}\} := (K\{L\}, S^3)$  is the *satellite* of  $\mathcal{K}$  with *pattern*  $\mathcal{L}$ ;  $\mathcal{K}$  is a *companion* of  $\mathcal{K}\{\mathcal{L}\}$ .

Stallings gave a natural condition under which a satellite with fibered companion and fibered pattern is itself fibered.

**2.10 Theorem** (Stallings [89]) *If  $\mathcal{K}$  and  $\mathcal{L}$  are fibered links in  $S_0^3$  and  $S_1^3$  respectively, and if, further, there exist an integer  $d \neq 0$  and open books  $\mathbf{p}: S_1^3 \rightarrow D^2$  for  $\mathcal{L}$  and  $\mathbf{o}: S_1^3 \rightarrow D^2$  for  $O$  with  $\mathbf{p} | E(O)$  equal to  $(\mathbf{o} | E(O))^d$  up to the identification above, then  $\mathcal{K}\{\mathcal{L}\}$  is a fibered link in  $S^3$ .*

The analogy mentioned in Remark 2.8 suggests that there should be a similarly broad result for a satellite with quasipositive companion and quasipositive pattern, presumably subject to some further coherence condition like that in Theorem 2.10. Lacking sufficient space, time, and insight either to find such a broad theorem or come up with convincing reasons none should exist, here I prove only a single narrow result to be used later.

For  $n \geq 1$ , denote by  $\mathcal{O}^{(n)} := (O^{(n)}, S^3)$  the closed braid of the identity  $o^{(n)} \in B_n$ , embedded — as in Section 2.1.1, Equation (2-1) — in  $J(S^1 \times \mathbb{C}) = \text{Int } N(O^1) \subset S^3 = S_1^3$ . The *untwisted  $n$ -strand cable* of a knot  $\mathcal{K} = (K, S_0^3)$  is the satellite  $\mathcal{K}\{n, 0\} := \mathcal{K}\{\mathcal{O}^{(n)}\}$ .

**2.11 Proposition** *If  $\mathcal{K}$  is quasipositive, then for all  $n \geq 1$ ,  $\mathcal{K}\{n, 0\}$  is quasipositive.*

**Proof** Realize the quasipositive knot  $\mathcal{K}$  as a transverse  $\mathbb{C}$ -link — say  $\mathcal{K} = \mathcal{L}(f, S^3)$  — with non-singular  $\mathbb{C}$ -span  $S(f, D^4)$ . For all sufficiently small  $\varepsilon \neq 0$ ,  $(V(f^n - \varepsilon^n) \cap S^3, S^3)$  is then a transverse  $\mathbb{C}$ -link with  $n$  components  $(V(f - \varepsilon e^{2k\pi i/n}) \cap S^3, S^3)$ , each a transverse  $\mathbb{C}$ -link in its own right, and such that its  $\mathbb{C}$ -span  $S_k := (V(f - \varepsilon e^{2k\pi i/n}) \cap D^4, D^4)$  is non-singular. For  $1 \leq k < \ell \leq n$ , clearly  $S_k \cap S_\ell = \emptyset$ , so the linking number of  $\partial S_k$  and  $\partial S_\ell$  in  $S^3$  is 0; it follows that  $\mathcal{L}(f^n - \varepsilon^n, S^3)$  is, up to ambient isotopy,  $\mathcal{K}\{n, 0\}$ . □

**2.12 Remarks** (1) For another proof of [Proposition 2.11](#), let  $\mathcal{K}$  be the closed braid

$$\widehat{\text{br}(\vec{b})}$$

of a quasipositive band representation  $\vec{b}$  in  $B_p$ ; fairly obvious algebraic manipulations (motivated by geometry) generate a quasipositive band representation  $\vec{b}\{n, 0\}$  in  $B_{np}$  with closure  $\mathcal{K}\{n, 0\}$ .

(2) The proof just sketched readily generalizes to show that  $\mathcal{K}\{\mathcal{L}\}$  is quasipositive in case both the companion  $\mathcal{K}$  and the pattern  $\mathcal{L}$  are quasipositive *and in addition*  $L$  sits inside  $N(O)$  as a quasipositive closed braid. Certainly, this last hypothesis *is* a “coherence condition like that in [Theorem 2.10](#)”, but it seems much too strong to be optimal (and is much stronger than Stallings’s condition).

(3) In the situation of (2) above, if also the quasipositive companion  $\mathcal{K}$  is a slice knot, then an analytic proof that  $\mathcal{K}\{\mathcal{L}\}$  is quasipositive can be cobbled together along the lines of the (first) proof of [Proposition 2.11](#) by using techniques applied (in a much more delicate context) by Baader, Kutzschebauch, and Wold [4].

### 2.3 Construction: strongly quasipositive links

The monoid  $Q_n$  contains a distinguished finite subset

$$\{\sigma_{i,j} := \sigma_i \cdots \sigma_{j-2} \sigma_{j-1} : 1 \leq i \leq j \leq n-1\}$$

of positive bands called *embedded bands* (in  $B_n$ ) by Rudolph [68] and later, a bit confusingly, simply “band generators” (of  $B_n$ ) by Birman, Ko, and Lee [8]. The calculus of band representations and Seifert ribbons in  $D^4$  mentioned in [Section 2.1.1](#) has a variant (expounded, like it, in [68], and elaborated in various later papers by Rudolph [72; 73; 76; 78], Baader and Ishikawa [2; 3], etc) by which *quasipositive embedded band representations*  $\vec{b}$  and algebraic/combinatorial operations thereon correspond to *quasipositive braided Seifert surfaces*  $S(\vec{b})$  in  $S^3$  and geometric/topological operations thereon. A Seifert surface is called *quasipositive* in case it is ambient isotopic to a quasipositive braided Seifert surface  $S(b)$ .

Given a compact orientable 2-manifold-with-boundary  $M$ , call a closed subset  $N \subset \text{Int } M$  *full* on  $M$  in case no component of  $M \setminus N$  is contractible.

**2.13 Proposition** (Rudolph [72]) *A Seifert surface is quasipositive if and only if it is a full subsurface of some quasipositive fiber surface. In particular, a full subsurface of a quasipositive Seifert surface is quasipositive.*

A link is *strongly quasipositive* in case it has a quasipositive Seifert surface. Many interesting quasipositive links are strongly quasipositive, including the classes of examples described next.

### 2.3.1 Strongly quasipositive annuli

**2.14 Theorem** (Rudolph [73; 74; 75]) (1) *If the smooth classical knot  $\mathcal{K}$  is non-trivial, then the following are equivalent:*

- (a) *The annular Seifert surface  $\mathcal{A}(\mathcal{K}, n)$  is quasipositive.*
- (b) *The oriented link  $(\partial \mathcal{A}(\mathcal{K}, n), S^3)$  is strongly quasipositive.*
- (c)  $n \leq \text{TB}(\mathcal{K})$ .

(2) *The oriented link  $(\partial \mathcal{A}(\mathbb{C}, n), S^3)$  is strongly quasipositive if and only if  $n \leq 0$ ; the annular surface  $\mathcal{A}(\mathbb{C}, n)$  is quasipositive if and only if  $n \leq -1 = \text{TB}(\mathbb{C})$ .*

### 2.3.2 Strongly quasipositive Murasugi sums

**2.15 Theorem** (Rudolph [76]) *A Murasugi sum of Seifert surfaces  $F_1$  and  $F_2$  is quasipositive if and only if the summands  $F_1$  and  $F_2$  are quasipositive.*

**2.16 Remarks** (1) Evidently  $\mathcal{S}(\mathbb{C}, 2) = |\mathcal{A}(\mathbb{C}, -1)|$ , so Theorems 2.14(2) and 2.15 imply that if each plumband of a Hopf-plumbed Seifert surface  $F$  (as in Definition 2.4(2)) is  $\mathcal{S}(\mathbb{C}, 2)$ , then  $(\partial F, S^3)$  is strongly quasipositive.

(2) Theorem 2.15 is analogous to Gabai's theorem [28] that a Murasugi sum of Seifert surfaces is a fiber surface if and only if the plumbands are fiber surfaces, and may be taken as further evidence (along different geometric lines from those followed in [27; 28] and later work by Gabai and others) for what Ozbagci and Popescu-Pampu [64] call *Gabai's credo*: "the Murasugi sum is a natural geometric operation".

**2.3.3 Positive links** Given a classical oriented link diagram  $\mathbf{D}$ , let  $\text{SA}(\mathbf{D})$  denote the Seifert surface (unique up to ambient isotopy) produced by *Seifert's algorithm* (Seifert [87]) applied to  $\mathbf{D}$ , so  $\mathcal{L}(\mathbf{D}) := (\partial \text{SA}(\mathbf{D}), S^3)$  is the oriented link (unique up to ambient isotopy) determined by  $\mathbf{D}$ . A diagram is *positive* in case every crossing is positive; a link is *positive* in case it has some positive  $\mathbf{D}$ . Positivity (of links and diagrams) is preserved by simultaneous reversal of all orientations; in particular, for *knots* it is independent of orientation.

**2.17 Theorem** (Nakamura [54; 55], Rudolph [77]) *If  $\mathbf{D}$  is positive, then  $\text{SA}(\mathbf{D})$  is a quasipositive Seifert surface. In particular, a positive link is strongly quasipositive.*

**2.3.4 Strongly quasipositive satellites (new)** Two results stated for quasipositive knots and links in Section 2.2 remain true in the strongly quasipositive case. In the first, a variation on Proposition 2.11, the proofs differ a bit.

**2.18 Proposition** *If  $\mathcal{K}$  is strongly quasipositive, then for all  $n \geq 1$ ,  $\mathcal{K}\{n, 0\}$  is strongly quasipositive.*

**Proof** Let  $S$  be a quasipositive Seifert surface with  $\mathcal{K} = (\partial S, S^3)$ . Let  $c: S \times [1, n] \rightarrow S^3$  be an embedding onto a one-sided collar of  $S = c(S \times \{1\})$ ; then  $c(S \times \{1, \dots, n\})$  is a quasipositive Seifert surface, and its boundary is clearly  $\mathcal{K}\{n, 0\}$ .  $\square$

The second is a variation on Remarks 2.12(2); in this case, the sketched proof of the original applies equally well to the variation.

**2.19 Proposition** *If both the companion  $\mathcal{K}$  and the pattern  $\mathcal{L}$  are strongly quasipositive, and if in addition  $L$  sits inside  $N(O)$  as a strongly quasipositive closed braid, then the satellite  $\mathcal{K}\{\mathcal{L}\}$  is strongly quasipositive.*

**2.4 Construction: partially reoriented Hopf links (new details)**

The partially reoriented positive Hopf links  $\mathcal{H}_+(p, q)$  and their mirror images the partially reoriented negative Hopf links  $\mathcal{H}_-(p, q) := \text{Mir } \mathcal{H}_+(p, q)$  are defined using the positive Hopf fibration  $h_+: S^3 \rightarrow \mathbb{C}P^1 : (z_0, z_1) \mapsto (z_0 : z_1)$  and its mirror image the negative Hopf fibration  $h_- : (z_0, z_1) \mapsto (\overline{z_0} : \overline{z_1})$ . The usual orientations of  $S^3 \subset \mathbb{C}^2$  and  $\mathbb{C}P^1$  naturally orient the fibers of  $h_\pm$ . For  $0 \neq p \geq q \geq 0$ , denote by  $H_\pm(p, q)$  the union of (any)  $p + q$  fibers of  $h_\pm$ ,  $p$  with the natural orientation and  $q$  with its opposite; let  $\mathcal{H}_\pm(p, q) := (H_\pm(p, q), S^3)$ . Note that  $\mathcal{H}_+(1, 0)$  and  $\mathcal{H}_-(1, 0)$  are ambient isotopic (they are trivial knots), as are  $\mathcal{H}_\pm(2, 0)$  and  $\mathcal{H}_\mp(1, 1)$ ; with those exceptions,  $\mathcal{H}_\pm(p, q)$  is determined up to ambient isotopy by  $(\pm, p, q)$ . Let  $\nabla_n := ((\sigma_1\sigma_2 \cdots \sigma_{n-1})(\sigma_1\sigma_2 \cdots \sigma_{n-2}) \cdots (\sigma_1\sigma_2)\sigma_1)^2 =: \Delta \in B_n$ . It is standard that the closure of  $\nabla_n$  is  $\mathcal{H}_\pm(n, 0)$ . For  $1 \leq i < j \leq n$ , inject  $B_{j-i+1}$  into  $B_n$  by  $\iota_{i,j}$  with  $\iota_{i,j}(\sigma_k) = \sigma_{k+i-1}$ ,  $k = 1, \dots, j - i$ ; let  $\nabla_{i,j} := \iota_{i,j}(\nabla_{j-i+1})$ . Figure 2(a)–(b) shows that

$$\begin{aligned} \nabla_{p+q} &= \nabla_{1,p} \nabla_{p+1,p+q} (\sigma_p \sigma_{p+1} \cdots \sigma_{p+q-1}) (\sigma_{p-1} \sigma_p \cdots \sigma_{p+q-2}) \cdots (\sigma_1 \sigma_2 \cdots \sigma_q) \\ &\quad \cdot (\sigma_q \sigma_{q+1} \cdots \sigma_{q+p-1}) (\sigma_{q-1} \sigma_q \cdots \sigma_{q+p-2}) \cdots (\sigma_1 \sigma_2 \cdots \sigma_p) \\ &= \nabla_{1,p-q} \nabla_{p-q+1,p+q} (\sigma_{p-q} \sigma_{p-q+1} \cdots \sigma_{p-1}) (\sigma_{p-q-1} \sigma_{p-q} \cdots \sigma_{p-2}) \\ &\quad \cdots (\sigma_1 \sigma_2 \cdots \sigma_{p-q}) (\sigma_{p-q} \sigma_{p-q+1} \cdots \sigma_{p+q-1}) \\ &\quad \cdot (\sigma_{p-q-1} \sigma_q \sigma_{p+q-2}) \cdots (\sigma_1 \sigma_2 \cdots \sigma_{2q}) \end{aligned}$$



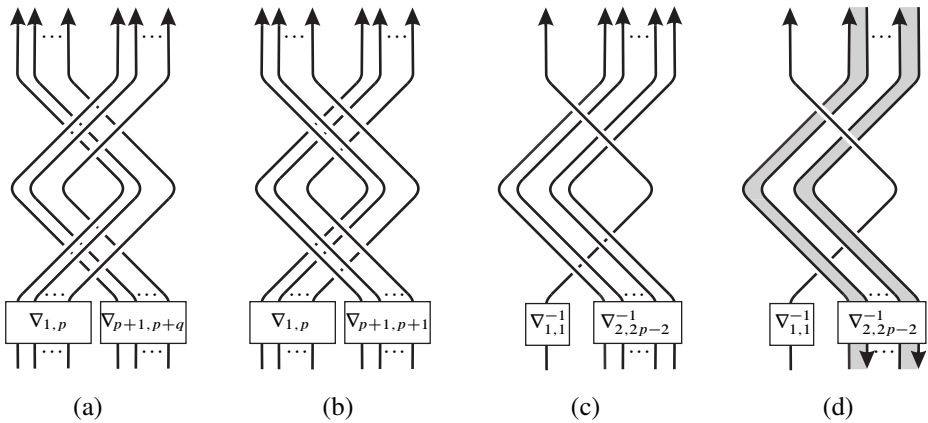

Figure 2: (a), (b), (c) Braid diagrams with closure  $\mathcal{H}_+(p + q, 0)$ ,  $\mathcal{H}_+(p, q)$ ,  $\mathcal{H}_-(2p - 1, 0)$  respectively. (d) A partially reoriented braid diagram with closure  $\mathcal{H}_-(p, p - 1)$ ; the shading indicates  $p - 1$  linked and twisted annuli that are components of a ribbon-immersed surface in  $S^3$  bounded by  $\mathcal{H}_-(p, p - 1)$  (the remaining component is a disk, not indicated).

and thus both have closure  $\mathcal{H}_+(p + q, 0)$ .

(Since  $\iota_{1,r}(B_r)$  and  $\iota_{r+1,p+q}(B_{p+q-r})$  commute with each other for any  $r = 1, \dots, p + q$ , the detailed placement of crossings inside the boxes at the bottoms of the diagrams is irrelevant; a similar observation applies to the tops of the diagrams.) The braid diagram in Figure 2(c) is derived from that in Figure 2(a) by simultaneously reversing the orientations of the rightmost  $q$  strings and turning those strings, so grouped, by (approximately) a half-turn around the horizontal axis; its closure is evidently  $\mathcal{H}_+(p, q)$ . Although Figure 2(d) — derived from Figure 2(b) by reversing the orientation of alternate ones of the last  $2q$  strings — is not a braid diagram for  $q > 0$ , it has an obvious “closure” that is, again evidently,  $\mathcal{H}_+(p, q)$ . (The shading in Figure 2(d) is for future reference.)

**2.20 Lemma** *Let  $p \geq q \geq 0$ .*

- (1)  $\mathcal{H}_+(p, q)$  is quasipositive if and only if  $p \geq 1$  and  $q = 0$ .
- (2)  $\mathcal{H}_-(p, q)$  is quasipositive if and only if either  $q = p > 0$  or  $q = p - 1$ .

In particular, a Seifert surface diffeomorphic to  $D^2$  is a fiber surface bounded by the trivial fibered knot  $\mathbb{C} = \mathcal{H}_\pm(1, 0)$ ; and a Seifert surface  $\mathcal{A}(\mathcal{H}, n)$  diffeomorphic to an annulus (see Section 2.3.1 for the notation) is a fiber surface if and only if it is a  $\pm$ -ive Hopf band  $\mathcal{A}(\mathbb{C}, \mp 1)$  bounded by the fibered  $\pm$ -ive Hopf link  $\mathcal{H}_\pm(2, 0) = \mathcal{H}_\mp(1, 1)$ .

## 2.5 Construction: quasipositive fibered links (new details)

**2.21 Lemma** For  $p > 1$ ,  $\mathcal{H}_\pm(p, q)$  is a fibered link if and only if  $p > q$ .

**Proof** Calculations in the style of Rudolph [71] show that if  $p > q$  then the real-polynomial mapping

$$F_{p,q}: \mathbb{C}^2 \rightarrow \mathbb{C}, \quad (z_0, z_1) \mapsto (z_0^p + z_1^p)(\overline{z_0}^q + 2\overline{z_1}^q)$$

has an isolated critical point at  $(0, 0)$ , and in fact that  $F_{p,q} | S^3$  is an open book with binding  $\mathcal{H}_+(p, q)$ ; the result for  $\mathcal{H}_-(p, q)$  follows by taking mirror images. On the other hand, if  $p > 1$  then  $\mathcal{H}_\pm(p, p)$  is not fibered (it has a disconnected Seifert surface, so  $S^3 \setminus H_\pm(p, p)$  has non-trivial second homology and cannot be homotopy equivalent to a bouquet of 1–spheres). Alternatively, note that a partially reoriented Hopf link is *solvable* in the sense of Eisenbud and Neumann [18] and then apply the characterization of fibered solvable links derived in [18] using the calculus of splice diagrams.  $\square$

In combination with Lemma 2.20, Lemma 2.21 yields the following.

**2.22 Corollary**  $\mathcal{H}_p(q, \cdot)$  is both quasipositive and fibered if and only if it is the trivial knot, the positive Hopf link,  $\mathcal{H}_+(p, 0)$ , or  $\mathcal{H}_-(p, p - 1)$ .

Let  $\mathcal{L}$  be a simple fibered link in  $S^{2n+1}$ ,  $\mathbf{p}$  an open book with  $\mathcal{L} = \mathcal{L}_{\mathbf{p}}$ . The Milnor number  $\mu(\mathcal{L})$  is now usually defined as the middle Betti number of the fiber  $2n$ –manifold of  $\mathcal{L}$ , making the following properties evident.

- 2.23 Proposition**
- (1)  $\mu(\mathcal{L}) \geq 0$ .
  - (2)  $\mu(\text{Mir } \mathcal{L}) = \mu(\mathcal{L})$ .
  - (3)  $\mu(\mathcal{L}) = 0$  if and only if the fiber  $2n$ –manifold is contractible; in particular, for  $n = 1$ ,  $\mu(\mathcal{L}) = 0$  if and only if  $\mathcal{L} = \mathbb{C}$  is a trivial knot.
  - (4) If  $\mathcal{L}_1$  and  $\mathcal{L}_2$  are fibered links, then  $\mu(\mathcal{L}_1 \# \mathcal{L}_2) = \mu(\mathcal{L}_1) + \mu(\mathcal{L}_2)$ .

Originally, however,  $\mu$  was defined by Milnor [52] (in his context of links  $\mathcal{L}_{\mathbf{z}}(f)$  of isolated singular points of complex hypersurfaces  $V(f) \subset \mathbb{C}^{n+1}$ ,  $n \geq 1$ , where  $\mathbf{p} = f | S^{2n+1}(\mathbf{z}, \varepsilon)$ ) as the degree of a map  $S^{2n+1} \rightarrow S^{2n+1}$  naturally associated to  $\mathbf{p}$ , while the Betti number characterization was a theorem to be proven and Proposition 2.23(1)–(3) were its corollaries (in Milnor’s context, Proposition 2.23(4) arises only trivially).

For  $n = 1$ , Rudolph [71] adapted Milnor’s original approach to  $\mu$  to define for every fibered classical link  $\mathcal{L}$ —in terms of any open book  $\mathbf{p}$  with  $\mathcal{L} = \mathcal{L}_{\mathbf{p}}$ —a pair

$(L_{\mathcal{L}}, R_{\mathcal{L}})$  of maps  $S^3 \rightarrow S^2$  naturally associated to  $\mathbf{p}$ . In [71], the pair  $(\lambda(\mathcal{L}), \rho(\mathcal{L}))$  of Hopf invariants of  $(L_{\mathcal{L}}, R_{\mathcal{L}})$  was called the *enhanced Milnor number* of  $\mathcal{L}$ , and shown to have the following properties.

- 2.24 Proposition** (1)  $\lambda(\mathcal{L}) + \rho(\mathcal{L}) = \mu(\mathcal{L})$ .  
 (2)  $\rho(\mathcal{L}) = \lambda(\text{Mir } \mathcal{L})$ .  
 (3)  $\lambda(\mathcal{L}_{\mathbf{z}}(f)) = 0$  if  $f: \mathbb{C}^2 \rightarrow \mathbb{C}$  is a holomorphic function with an isolated critical point (or regular point) at  $\mathbf{z} \in \mathbb{C}^2$ .  
 (4)  $\lambda$  is additive over connected sum:  $\lambda(\mathcal{L}_1 \# \mathcal{L}_2) = \lambda(\mathcal{L}_1) + \lambda(\mathcal{L}_2)$ .

Neumann and Rudolph [59; 60; 61] named  $\lambda(\mathcal{L})$  (and its analogue for fibered links of higher odd dimension, an element of  $\mathbb{Z}/2\mathbb{Z}$  rather than  $\mathbb{Z}$ ) the *enhancement* of  $\mathcal{L}$ . They introduced a notion of an open book  $\mathbf{b}$  (or its fibered link  $\mathcal{L}_{\mathbf{b}}$ ) *unfolding* into open books  $\mathbf{b}_i$  (or their fibered links  $\mathcal{L}_{\mathbf{b}_i}$ ), denoted by  $\mathbf{b} = \Upsilon_i \mathbf{b}_i$  (or  $\mathcal{L}_{\mathbf{b}} = \Upsilon_i \mathcal{L}_{\mathbf{b}_i}$ ); with their definition,  $\lambda(\mathcal{L}_{\mathbf{b}_1 \Upsilon \mathbf{b}_2}) = \lambda(\mathcal{L}_{\mathbf{b}_1}) + \lambda(\mathcal{L}_{\mathbf{b}_2})$  is tautologous. They also show that unfolding includes Murasugi sum in the sense that for any open books  $\mathbf{b}_1, \mathbf{b}_2$  on  $S^3$ , pages  $F_i$  of  $\mathbf{b}_i$ , and Murasugi sum  $F = F_1 * F_2$ , there exists an unfolding  $\mathbf{b} = \mathbf{b}_1 \Upsilon \mathbf{b}_2$  with  $F$  as a page. The generalization of Proposition 2.24(4) from connected sum to Murasugi sum follows immediately.

In [61] Neumann and Rudolph applied the calculus of splice diagrams [18] to calculations of the enhancement for various classes of fibered links. In particular, Proposition 9.3 of [61] (stated for a pair of coaxial torus knots but true for a pair of coaxial torus links in general) includes the following calculation, which can also be derived by a pleasant exercise using the techniques of [71].

- 2.25 Proposition** For  $p > q \geq 0$ ,  $\lambda(\mathcal{H}_-(p, q)) = 2q - q^2$ .

At an Oberwolfach Research-in-Pairs-Workshop on 3-manifolds and singularities convened (for a large value of “pair”) by N A’Campo in 2000, several participants noticed simultaneously that when the map  $L_{\mathcal{L}, \mathbf{p}}: S^3 \rightarrow S^2$  is taken to be a field of oriented tangent 2-planes on  $S^3$  (as in [71]), it is clearly isotopic to (and arbitrarily close to) a contact structure  $\xi_{\mathbf{b}}$  on  $S^3$  for which  $\xi_{\mathbf{b}}$  and  $\mathbf{b}$  are *compatible* in the sense of Thurston and Winkelnkemper [91] (alternatively,  $\xi_{\mathbf{b}}$  is *supported* by  $\mathbf{b}$  in the sense of Giroux [32]) and the Hopf invariant of  $\xi_{\mathbf{b}}$  (as a plane field) equals  $\lambda(\mathcal{L}_{\mathbf{b}})$ .

**2.26 Theorem** (Giroux [32]; see also Giroux and Goodman [33]) *Every contact structure on  $S^3$  is ambient isotopic to a contact structure  $\xi_{\mathbf{b}}$  compatible with some open book  $\mathbf{b}$  on  $S^3$ ;  $\xi_{\mathbf{b}_0}$  and  $\xi_{\mathbf{b}_1}$  are homotopic if and only if the fiber surfaces of  $\mathcal{L}_{\mathbf{b}_0}$  and  $\mathcal{L}_{\mathbf{b}_1}$  are stably equivalent under the operation  $F \mapsto F *_{\mathbf{p}} \mathcal{A}(\mathbb{C}, -1)$  of positive Hopf plumbing.*

**2.27 Theorem** ([80]; see also Hedden [40]) *A fibered link  $\mathcal{L} = \mathcal{L}(\mathbf{b})$  in  $S^3$  is strongly quasipositive if and only if up to ambient isotopy  $\mathbf{b}$  is compatible with the standard, contact structure  $\xi_0$  on  $S^3$ .*

In light of [Theorem 2.27](#), the following may be somewhat surprising.

**2.28 Proposition** *Every contact structure on  $S^3$  is homotopic to a contact structure  $\xi_{\mathbf{b}}$  compatible with an open book  $\mathbf{b}$  with non-strongly quasipositive binding.*

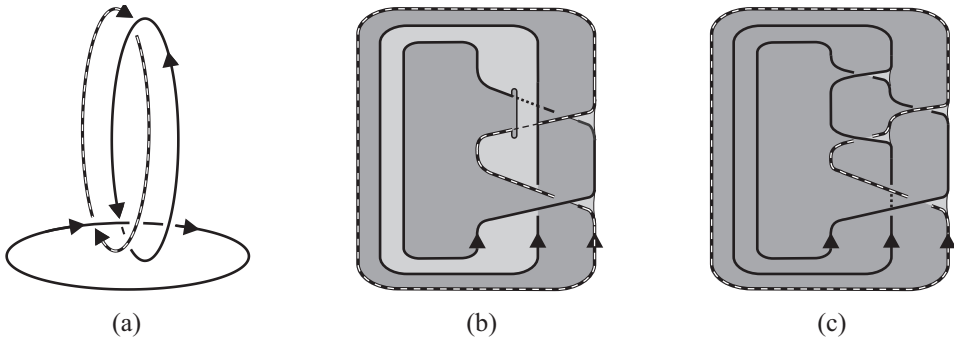

Figure 3: (a)  $\mathcal{H}_-(3, 2) = \mathcal{L}_\infty(z_0(z_0z_1 - 1))$ . (b)  $\mathbb{C}$ -span of  $\mathcal{L}_\infty(z_0(z_0z_1 - 1))$  in  $D^4(\mathbf{0}, 1/\varepsilon)$ , represented as a ribbon-immersed surface in  $S^3$ . ([Figure 2\(d\)](#) suggests the analogous surface for any  $\mathcal{H}_-(p, p-1)$  with  $p \geq 3$ .) (c) The fiber surface of  $\mathcal{L}_\infty(z_0(z_0z_1 - 1))$ .

**Proof** Let  $q \geq 0$ . By [Corollary 2.22](#) and [Proposition 2.25](#),  $\mathcal{H}_-(q + 1, q)$  is a quasipositive fibered link with enhancement  $\lambda(\mathcal{H}_-(q + 1, q)) = 2q - q^2$ . In particular,  $\lambda(\mathcal{H}_-(2, 1)) = 1$  and  $\lambda(\mathcal{H}_-(q + 1, q)) \searrow -\infty$  as  $q \nearrow \infty$ . It follows from [Proposition 2.24\(4\)](#) that  $\lambda$  achieves every integer value on an appropriate connected sum

$$\mathcal{L}_{q,m} = \mathcal{H}_-(q + 1, q) \# \overbrace{\mathcal{H}_-(2, 1) \# \cdots \# \mathcal{H}_-(2, 1)}^{m \text{ times}}.$$

Connected sum preserves both quasipositivity and fiberedness, so by [Theorem 2.26](#) and the paragraph that precedes it the proof is complete except for the homotopy class of  $\xi_0$ . That case is covered by observing that  $\mathcal{H}_-(3, 2)$ , though quasipositive, is not strongly quasipositive — for instance (as illustrated in [Figure 3](#)) because it is realized as a 1-dimensional transverse  $\mathbb{C}$ -link by the link at infinity of  $z_0(z_0z_1 - 1)$ : since the Euler characteristic  $-1$  of its fiber surface (a pair of pants) is strictly smaller than that of its  $\mathbb{C}$ -span (the disjoint union of an annulus and a disk), the truth of the Thom conjecture (Kronheimer and Mrowka [47]) implies that the fiber surface is not quasipositive.  $\square$

## 2.6 Construction: quasipositive links with distinct $\mathbb{C}$ –spans (new)

Consider the quasipositive band representations

$$\begin{aligned} \vec{\rho}_0 &:= (\sigma_3^{-2}\sigma_2\sigma_1, \sigma_2, \sigma_1\sigma_3^3\sigma_2, \sigma_1\sigma_3^5\sigma_2^{-1}\sigma_1, \sigma_3, \sigma_3), \\ \vec{\rho}_1 &:= (\sigma_2, \sigma_1\sigma_3\sigma_2, \sigma_1\sigma_3\sigma_2, (\sigma_1\sigma_3)^2\sigma_2, (\sigma_1\sigma_3)^2\sigma_2, (\sigma_1\sigma_3)^3\sigma_2) \end{aligned}$$

in  $B_4$  and their associated quasipositive braided surfaces realized (as in Section 2.1.1) by  $\mathbb{C}$ –spans of 1–dimensional transverse  $\mathbb{C}$ –links  $\mathcal{L}(g_i, S^3)$  in  $S^3$ . Auroux, Kulikov, and Shevchishin [48] show that, although the braids  $\text{br}(\vec{\rho}_0)$  and  $\text{br}(\vec{\rho}_1)$  are equal, and  $S(g_0, D^4)$  is diffeomorphic to  $S(g_1, D^4)$  (both are twice-punctured tori),  $D^4 \setminus S(g_0, D^4)$  is not homeomorphic to  $D^4 \setminus S(g_1, D^4)$  (their fundamental groups are different). In particular, although  $\mathcal{L}(g_0, S^3)$  and  $\mathcal{L}(g_1, S^3)$  are ambient isotopic as smooth links in  $S^3$ , their  $\mathbb{C}$ –spans are not ambient isotopic as smooth 2–submanifolds-with-boundary in  $D^4$ . By appending  $\sigma_1^3\sigma_2$  to  $\rho_0$  and  $\rho_1$ , Geng [31] showed that even smoothly isotopic quasipositive *knots* can have (non-singular, diffeomorphic)  $\mathbb{C}$ –spans that are not ambient isotopic in  $D^4$  (again, the fundamental groups of their complements are not isomorphic).

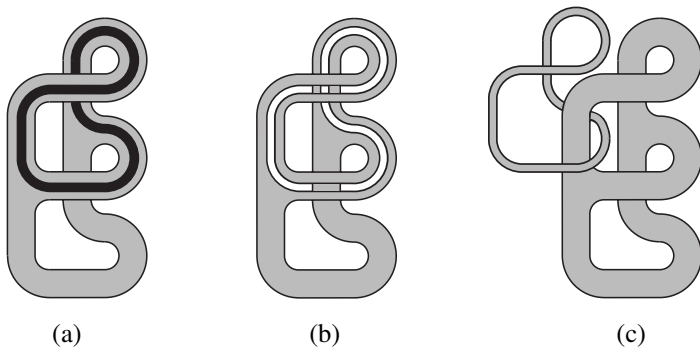

Figure 4: (a) A connected quasipositive Seifert surface  $S$  (gray) and an annular subsurface  $F \subset S$  (black). (b) The cut-open Seifert surface  $S \setminus \text{Int } F$  is again quasipositive, by Proposition 2.13. (c) The Seifert surface  $S \cup F^+$ , comprising  $S$  and the push-off of  $F$ , is quasipositive (again, by Proposition 2.13) and  $(\partial(S \cup F^+), S^3)$  is ambient isotopic to  $(\partial(S \setminus \text{Int } F), S^3)$  (by an isotopy that begins by rotating each component of  $F^+$  around a core  $S^1$  so as to interchange its two boundary components).

**2.29 Remark** Another, easier construction produces arbitrarily large finite sets of mutually ambient isotopic 1–dimensional transverse  $\mathbb{C}$ –links in  $S^3$  (in fact, strongly quasipositive links) with pairwise non-diffeomorphic  $\mathbb{C}$ –spans (all of the same Euler

characteristic); the simplest example, shown in Figure 4, suffices to illustrate the general method, which necessarily produces link-manifolds of at least 3 components.

### 2.7 Construction: quasipositive orientations of unoriented links (new)

Given an oriented manifold  $L$  with  $n \geq 1$  components, the unoriented manifold  $|L|$  supports  $2^n$  orientations and thus  $2^{n-1}$  projective orientations, each determined by an orientation and its componentwise opposite (Sakuma [81] uses the term *semi-orientation* for this concept). Write  $\mathfrak{o}$  for a projective orientation.

Let  $\mathcal{L} = (L, S^3)$  be an oriented classical link (with, as is usual, the orientation of  $L$  not included explicitly in the notation). As noted in Section 2.3.3,  $\mathcal{L}$  is positive if and only if its opposite  $-\mathcal{L} := (-L, S^3)$  is positive, the proof being consideration of any link diagram of  $\mathcal{L}$ . Similarly,  $\mathcal{L}$  is quasipositive if and only if  $-\mathcal{L}$  is; here the proof is to note that reversing the orientation of a braid diagram with closure  $\mathcal{L}$ , then rotating it by  $\pi$  in its plane, makes it into a braid diagram with closure  $-\mathcal{L}$ , and that this operation preserves diagrammatic quasipositivity. One might expect that at most one projective orientation of an unoriented classical link makes it quasipositive, and that is the case with a few exceptions (eg, a trivial knot; split links of two or more positive knots;  $|\mathcal{H}_\pm(2, 0)| = |\mathcal{H}_\pm(1, 1)|$ ).

This section collects several useful examples of families of unoriented classical links in which each member supports a projective orientation (typically but not invariably unique) that makes it quasipositive — briefly, a *quasipositive orientation*.

**2.7.1 Quasipositive orientations of unknotted strip boundaries** Let  $\mathcal{K}$  be a classical knot,  $t$  an integer, and  $\mathcal{P}(\mathcal{K}, t)$  the strip of type  $\mathcal{K}$  with  $t$  half-twists as defined in Definition 2.1. The unoriented link  $(\partial\mathcal{P}(\mathcal{K}, t), S^3)$  has 1 or 2 components according as  $t$  is odd or even. In both cases, let  $\mathfrak{o}$  be the “braidlike” projective orientation, so that  $(\partial\mathcal{P}(\mathcal{K}, t)^\mathfrak{o}, S^3) =: \mathcal{K}\{2, t\}$  is the 2-strand cable on  $\mathcal{K}$  with  $t$  half-twists. (Both the notation  $\mathcal{K}\{m, n\}$ , already introduced for  $n = 0$ , and its iterated extension  $\mathcal{K}\{m_1, n_1; m_2, n_2; \dots; m_q, n_q\} := \mathcal{K}\{m_1, n_1\}\{m_2, n_2\} \cdots \{m_q, n_q\}$ , are adapted from Litherland [49]; this is reasonably consistent with the notation for satellites.) In case  $t$  is even, let  $\mathfrak{o}'$  be the “non-braidlike” projective orientation. (See Figure 5(a) and (c).)

- 2.30 Proposition** (1)  $(\partial\mathcal{P}(\mathbb{O}, t)^\mathfrak{o}, S^3) = \mathbb{O}\{2, t\}$  is (strongly) quasipositive if and only if  $t \geq 0$ .
- (2)  $(\partial\mathcal{P}(\mathbb{O}, t)^{\mathfrak{o}'}, S^3)$  is (strongly) quasipositive if and only if  $t = 2s \leq 0$ ; then it is  $(\partial\mathcal{A}(\mathbb{O}, s), S^3)$ .

**2.31 Remark** Similar results for  $\mathcal{K} \neq \mathbb{O}$  are true but more complicated to state.

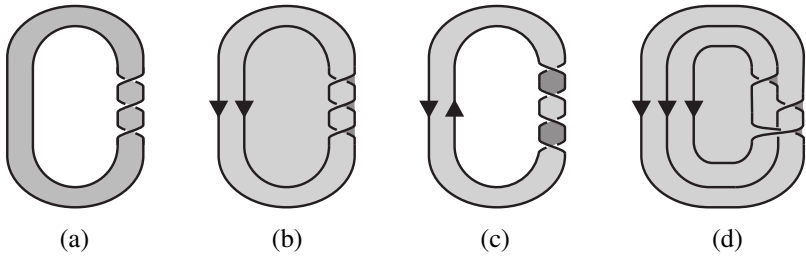

Figure 5: (a) The unoriented unknotted strip  $\mathcal{S}(\mathbb{O}, 3)$  with 3 half-twists, and its unoriented boundary. (b) For  $t > 0$ ,  $\partial\mathcal{S}(\mathbb{O}, t)^\circ$  bounds the quasipositive braided Seifert surface  $S(\sigma_1, \dots, \sigma_t)$  with all  $b_i = \sigma_1 \in B_2$ . (c) For  $s < 0$ ,  $\partial\mathcal{S}(\mathbb{O}, 2s)^\circ$  bounds the quasipositive annular Seifert surface  $\mathcal{A}(\mathbb{O}, s)$ . (d)  $\mathcal{A}(\mathbb{O}, -2)$  as the quasipositive braided Seifert surface  $S(\sigma_1 \sigma_2, \sigma_2, \sigma_1)$ .

**2.7.2 Quasipositive rational links** The torus link  $\mathbb{O}\{2, k\}$  in Section 2.7.1 is well known to be a fibered link for  $k \neq 0$ ; its fiber surface is the braided Seifert surface  $S = S(\sigma_1^{\text{sgn}(k)}, \dots, \sigma_t^{\text{sgn}(k)})$  (with  $|k|$  bands), illustrated for  $k = 3$  in Figure 5(b). In fact,  $\mathbb{O}\{2, k\}$  is both a Hopf-plumbed link as defined in Definition 2.4(2) and — with its orientation forgotten — an arborescent link as defined in Definition 2.4(3). More precisely, in this last guise  $|\mathbb{O}\{2, k\}|$  is an unoriented rational link

$$\mathfrak{R}(\overbrace{-2, -2, \dots, -2}^{k-1}) := (R(\overbrace{-2, -2, \dots, -2}^{k-1}), S^3),$$

where, for  $r_1, \dots, r_n \in \mathbb{Z} \setminus \{0\}$ ,  $R(r_1, r_2, \dots, r_n)$  denotes the boundary of a 2-manifold-with-boundary  $\text{sp}(\text{stick}(r_1, r_2, \dots, r_n))$  strip-plumbed as in Figure 6(a) according to a stick — that is, a tree (a finite connected acyclic 1-dimensional simplicial complex) with no nodes (vertices of valence 3 or greater) equipped with a weighting of its vertices by integers; Figure 6(b) is a standard depiction of a stick.

Clearly  $\text{sp}(\text{stick}(r_1, r_2, \dots, r_n))$  is orientable if and only if all  $r_i$  are even, and then  $\mathfrak{R}(r_1, \dots, r_n)$  has a preferred projective orientation  $\circ$ . If also  $r_i < 0$  for all  $i$ , then (by Theorem 2.14 and Theorem 2.15)  $\text{sp}(\text{stick}(r_1, \dots, r_n))$  is a quasipositive Seifert surface, and  $\mathfrak{R}(r_1, \dots, r_n)^\circ$  is strongly quasipositive. But these sufficient conditions for  $\mathfrak{R}(r_1, \dots, r_n)$  to have a (strongly) quasipositive orientation are far from necessary. The following is true by inspection.

**2.32 Proposition** *The rational link-manifold  $R(r_1, \dots, r_n)$  has a projective orientation  $\circ$  which, applied to the 4-plat diagram in Figure 6(c), makes it a positive diagram if and only if the braid  $\sigma_2^{r_1} \sigma_3^{r_2} \sigma_3^{r_3} \cdots \sigma_\ell^{r_n} \in B_4$  (with  $\ell$  equal to 3 or 2 according as  $n$  is even or odd) is generated by the labeled digraph in Figure 7.*

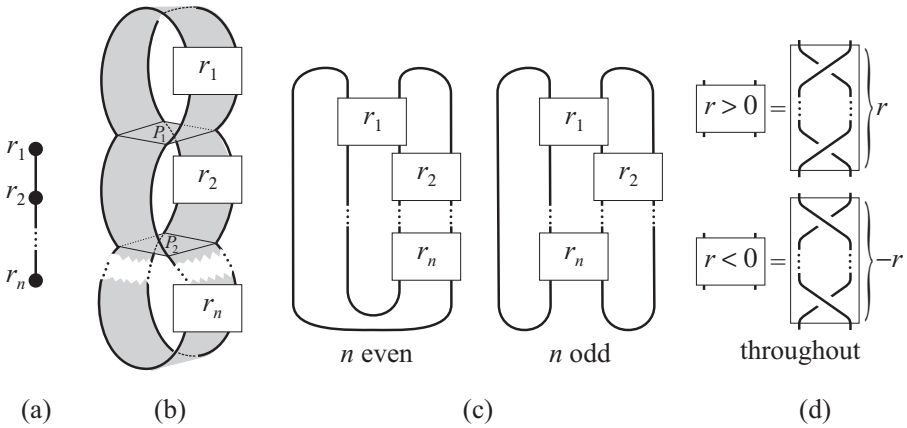

Figure 6: (a) The stick  $\text{stick}(r_1, r_2, \dots, r_n)$ . (b) The strip-plumbed surface  $\text{sp}(\text{stick}(r_1, r_2, \dots, r_n)) \subset S^3$ . (c) Rational link-manifold  $R(r_1, r_2, \dots, r_n)$  presented as the 4-plat of  $\sigma_2^{r_1} \sigma_3^{r_2} \dots \sigma_3^{r_n}$  ( $n$  even) or  $\sigma_2^{r_1} \sigma_3^{r_2} \dots \sigma_2^{r_n}$  ( $n$  odd), read top to bottom, with plat closure as indicated. (d) Sign conventions for the 2-string tangles in (b), (c), and elsewhere.

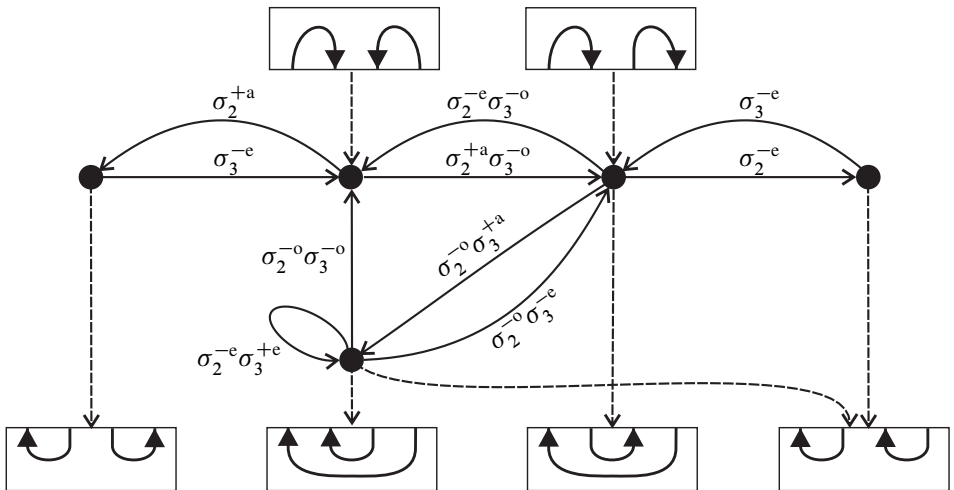

Figure 7: This machine generates all positive oriented rational links as 4-plats

Here,  $\beta \in B_4$  is generated by the labeled digraph in case there is a directed path from one of the (source) boxes at the top of the digraph to one of the (sink) boxes at the bottom of the digraph such that  $\beta$  is produced by first concatenating the labels on the labeled edges of the path and then replacing each instance of the letter “a” (respectively “e” or “o”) by an arbitrary (respectively even or odd) strictly positive integer.



**2.33 Questions** Proposition 2.32 gives expansive, but imperspicuous, sufficient conditions for  $\mathfrak{R}(r_1, r_2, \dots, r_n)$  to have a (strongly) quasipositive orientation.

- (1) What is a closed-form description (presumably one exists) of the set of rational numbers

$$r_1 + \frac{1}{-r_2 + \frac{1}{\dots + \frac{1}{(-1)^{n-1}r_n}}}$$

such that  $\sigma_1^{r_1} \sigma_2^{r_2} \dots \sigma_{(3\pm 1)/2}^{r_n}$  is generated as in Proposition 2.32?

- (2) Are the necessary and sufficient conditions for positivity given in Proposition 2.32 also necessary for strong quasipositivity? For quasipositivity? My tentative answers are “probably yes” and “almost certainly no”.

**2.34 Remark** The term “stick” is due to Bonahon and Siebenmann [12] (but there a stick may lack one or both terminal vertices yet retain its terminal edge or edges).

**2.7.3 Quasipositive pretzel links** Another guise in which  $|\mathbb{O}\{2, k\}|$  ( $k > 0$ ) appears is as the *unoriented pretzel link*

$$\mathfrak{P}(\overbrace{-1, \dots, -1}^{k \text{ times}}) := (P(\overbrace{-1, \dots, -1}^{k \text{ times}}), S^3)$$

where, for  $t_1, t_2, \dots, t_p \in \mathbb{Z}$ ,  $P(t_1, t_2, \dots, t_p)$  is the unoriented boundary of two unoriented 2-submanifolds-with-boundary of  $S^3$ , depicted in Figure 8(b) and (c).

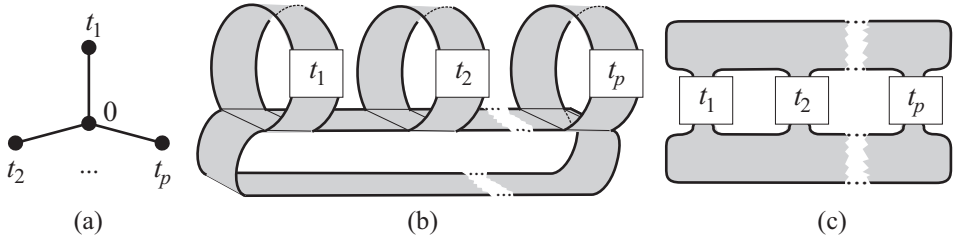

Figure 8: (a)  $\text{star}(0; t_1, t_2, \dots, t_p)$ . (b) Star surface  $\text{sp}(\text{star}(0; t_1, t_2, \dots, t_p))$ . (c) Pretzel surface  $\mathcal{P}(t_1, \dots, t_p)$ .

**2.35 Definitions** (1) The *star surface*  $\text{sp}(\text{star}(0; t_1, \dots, t_p))$  is strip-plumbed according to the *star*  $\text{star}(0; t_1, \dots, t_p)$ , where in general  $\text{star}(c; t_1, \dots, t_p)$  has a central node of weight  $c$  and  $p \geq 3$  *twigs* (terminal vertices) weighted  $t_1, \dots, t_p$  in the cyclic order determined by some planar embedding of a geometric realization, as depicted in Figure 8(b)).

- (2) The pretzel surface  $\mathcal{P}(t_1, \dots, t_p)$  is defined by its ordered handle decomposition into two 0–handles lying on  $S^2 \subset S^3$  and  $p \geq 3$  1–handles with core arcs lying on  $S^2$ , each of them joining the two 0–handles, and such that the  $i^{\text{th}}$  1–handle has twisting number  $t_k \in \mathbb{Z}$  (normalized so that, eg,  $\mathcal{P}(-1, -1, -1) = |\mathbb{C}\{2, 3\}|$ ).

**2.36 Remarks** (1) By [Proposition 2.13](#), [Theorem 2.14](#), and the non-orientability of  $\mathcal{P}(\mathbb{C}, t)$  for odd  $t$ , a star surface is orientable and has a quasipositive orientation if and only if all weights are even and strictly negative. In particular, the central plumband  $\mathcal{S}(\mathbb{C}, 0)$  of  $\text{sp}(\text{star}(0; t_1, \dots, t_p))$  keeps it from having a quasipositive orientation.

- (2) For  $c \neq 0$ ,  $\text{sp}(\text{star}(c; t_1, \dots, t_p))$  and  $\text{sp}(\text{star}(c; t_1, \dots, t_p, t_{p+1}, \dots, t_{p+|c|}))$ , where  $t_{p+j} = -\text{sgn } c$  for  $j = 1, \dots, |c|$ , have ambient isotopic boundaries.

The first claim in the following proposition is obvious; the necessity of the second claim follows from [Proposition 2.13](#), and its sufficiency was proved by Rudolph [79].

**2.37 Proposition** (1)  $\mathcal{P}(t_1, \dots, t_p)$  is orientable (with unique projective orientation  $\mathfrak{o}$ ) if and only if all  $t_i$  have the same parity.

- (2) If  $\mathcal{P}(t_1, \dots, t_p)$  is orientable, then  $\mathcal{P}(t_1, \dots, t_p)^{\mathfrak{o}}$  is quasipositive if and only if  $t_i + t_j < 0$  for  $1 \leq i < j \leq p$ .

[Proposition 2.37](#) is not the whole story on pretzel links with (strongly) quasipositive orientations. What was overlooked in [79] was that there are many  $(t_1, \dots, t_p)$  failing the parity condition [Proposition 2.37\(1\)](#), the negative-sum condition [Proposition 2.37\(2\)](#), or both, for which there nonetheless exists  $\mathfrak{o}$  making  $\mathfrak{P}(t_1, t_2, \dots, t_p)^{\mathfrak{o}}$  quasipositive. This can happen in (at least) two ways.

- (a)  $P(t_1, \dots, t_p)^{\mathfrak{o}}$  may bound a quasipositive non-embedded ribbon-immersed surface in  $S^3$ , but not bound any quasipositive Seifert surface, thus making  $\mathfrak{P}(t_1, \dots, t_p)^{\mathfrak{o}}$  quasipositive but not strongly quasipositive; the simplest knot of this type is  $\mathfrak{P}(-3, 3, -2)^{\mathfrak{o}}$ , depicted in [Figure 9\(a\)](#).
- (b)  $P(t_1, \dots, t_p)^{\mathfrak{o}}$  may be a positive link, and thus, by [Theorem 2.17](#), strongly quasipositive; this case is addressed by the following proposition.

**2.38 Proposition** *The following are equivalent.*

- (A)  $P(t_1, \dots, t_p)$  has a projective orientation  $\mathfrak{o}$  such that the oriented link diagram of  $\mathfrak{P}(t_1, \dots, t_p)^{\mathfrak{o}}$  implicit in [Figure 8\(c\)](#) is positive.
- (B) The positive projective orientations of the  $p$  2–string tangles indicated by the boxes labeled  $t_1, \dots, t_p$  in [Figure 8\(c\)](#) are consistent.

(C) Either

- (a) all  $t_i$  are odd and negative, or
- (b) no odd  $t_i$  is negative, and an even number of  $t_i$  are strictly positive.

**Proof** It is clear that (A) and (B) are equivalent. The equivalence of (B) and (C) follows by considering how the schematic templates for positive oriented 2-tangles shown in Figure 9(b) can fit together maintaining projectively consistent orientations with each other and with the trivial 2-tangle comprising the top and bottom of the diagram.  $\square$

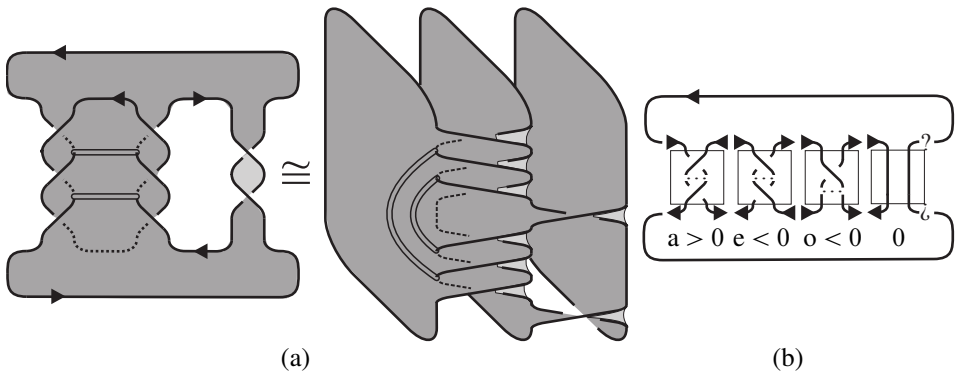

Figure 9: (a) Isotopic ribbon-immersed surfaces bounded by  $P(3, -3, -2)^o$  and the closure of the quasipositive braid  $\sigma_2 \sigma_1^3 \sigma_2 \sigma_1^{-3} \in B_3$ . (b) Templates for positive pretzels.

- 2.39 Questions** (1) The example depicted in Figure 9(a) can be generalized somewhat (eg, to  $P(2n + 1, -(2n + 1), -2m)$  for all  $m, n > 0$ ), but it is not immediately clear just how far. Are there useful criteria for a pretzel link to have a quasipositive orientation that is not strongly quasipositive? What about pretzel knots?
- (2) Excepting the case (covered by Proposition 2.37) in which  $t_i + t_j$  is even and strictly negative for  $1 \leq i < j \leq p$ , and one  $t_i$  is non-negative, can  $\mathfrak{P}(t_1, \dots, t_p)^o$  have a strongly quasipositive orientation  $\mathfrak{o}$  that does not make  $\mathfrak{P}(t_1, \dots, t_p)^o$  actually a positive link as in Proposition 2.38?

**2.7.4 Strongly quasipositive arborescent links** Three general methods produce large families of arborescent links supporting strongly quasipositive orientations; I do not know whether all such links are produced in one of these ways. To that extent (if not further; cf Questions 2.39(1)) this subsection is work in progress.

**2.40 Definitions** Let  $(\mathcal{T}, w)$  be a weighted tree.

- (1) Call  $(\mathcal{T}, w)$  *strongly quasipositive* in case there exists a projective orientation  $\mathfrak{o}$  of  $\partial \text{sp}(\mathcal{T}, w)$  such that  $(\partial \text{sp}(\mathcal{T}, w)^\mathfrak{o}, S^3)$  is a strongly quasipositive link.
- (2) Call  $(\mathcal{T}, w)$  *positive* in case there exists a projective orientation  $\mathfrak{o}$  of  $\partial \text{sp}(\mathcal{T}, w)$  such that the canonical unoriented link diagram of  $(\partial \text{sp}(\mathcal{T}, w)^\mathfrak{o}, S^3)$  (Gabai’s T–projection [29, Figure 1.4]; see also Bonahon and Siebenmann [12, Figure 12.12]), when endowed with  $\mathfrak{o}$ , becomes a positive oriented link diagram.
- (3) Call  $(\mathcal{T}, w)$  *very strongly quasipositive* in case there exists a projective orientation  $\mathfrak{o}$  of  $\text{sp}(\mathcal{T}, w)$  such that  $\text{sp}(\mathcal{T}, w)^\mathfrak{o}$  is a quasipositive Seifert surface.

(2) and (3) each imply (1); (1), (2), and (3) have no other non-trivial implications.

To explore these properties, a few more definitions are useful. Let  $\mathcal{T}$  be a planar tree with vertex set  $V(\mathcal{T})$ ,  $w: \mathcal{T} \rightarrow \mathbb{Z}$  a weighting. Writing  $d(v, v')$  for the number of edges in the simple edge-path in  $\mathcal{T}$  joining  $v, v' \in V(\mathcal{T})$ , call  $v$  and  $v'$  *adjacent* in case  $d(v, v') = 1$  and *distant* in case  $d(v, w) \geq 3$ . A vertex adjacent to at least three is a node of  $\mathcal{T}$ , and a vertex adjacent to at most one vertex is a twig of  $\mathcal{T}$ , as previously defined.

**2.41 Definitions** Let  $u$  be a non-node and  $v$  a node of  $\mathcal{T}$ .

- (1) Denote by  $\mathfrak{sk}(u, \mathcal{T})$  the subtree of  $\mathcal{T}$  such that  $u' \in V(\mathfrak{sk}(u, \mathcal{T}))$  if and only if no vertex of the simple edge-path in  $\mathcal{T}$  joining  $u$  to  $u'$  is a node. The weighted tree  $(\mathfrak{sk}(u, \mathcal{T}), w|_{\mathfrak{sk}(u, \mathcal{T})})$  is *the stick of  $u$  in  $(\mathcal{T}, w)$* ; it is isomorphic to  $\text{stick}(w(u'_1), \dots, w(u'_n))$ , where  $u'_1$  and  $u'_n$  are the twigs of  $\mathfrak{sk}(u, \mathcal{T})$  (so  $v'_1 = v'_n$  if and only if  $\mathfrak{sk}(u, \mathcal{T})$  has 0 edges) and  $d(v'_1, v'_q) = q - 1$  for  $q = 1, \dots, n$ .
- (2) Denote by  $\mathfrak{sr}(v, \mathcal{T})$  the subtree of  $\mathcal{T}$  such that  $v' \in V(\mathfrak{sr}(v, \mathcal{T}))$  if and only if  $d(v, v') \leq 1$ . The weighted tree  $(\mathfrak{sr}(v, \mathcal{T}), w|_{\mathfrak{sr}(v, \mathcal{T})})$  is *the star of  $v$  in  $(\mathcal{T}, w)$* ; it is isomorphic to  $\text{star}(w(v); w(v'_1), \dots, w(v'_p))$ , where  $v'_1, \dots, v'_p$  are the twigs of  $\mathfrak{sr}(v, \mathcal{T})$  enumerated consistently with the planar embedding of  $\mathcal{T}$ .

**2.42 Lemma** (1)  $\text{stick}(r_1, \dots, r_n)$  is positive if and only if  $\sigma_2^{r_1} \sigma_3^{r_2} \sigma_3^{r_3} \dots \sigma_\ell^{r_n}$  is generated by the machine in Figure 7.

- (2)  $\text{stick}(r_1, \dots, r_n)$  is very strongly quasipositive if and only if  $r_i$  is even and strictly negative for  $i = 1, \dots, n$  if and only if  $\sigma_2^{r_1} \sigma_3^{r_2} \sigma_3^{r_3} \dots \sigma_\ell^{r_n}$  is generated by the submachine obtained by deleting all but the five rightmost arrows in Figure 7.
- (3) If  $t_i + t_j$  is even and strictly negative for  $1 < i \leq j < p$ , then  $\text{star}(0; t_1, \dots, t_p)$  is strongly quasipositive; if also  $t_i < 0$  for all  $i$ , then  $\text{star}(0; t_1, \dots, t_p)$  is positive.

- (4) If no odd  $t_i$  is negative, and an even number of  $t_i$  are strictly positive, then  $\text{star}(0; t_1, \dots, t_p)$  is positive.
- (5) If  $c > 0$ , all  $t_i$  are odd and negative, and  $c + p$  is even, then  $\text{star}(c; t_1, \dots, t_p)$  is positive.
- (6) If  $c$  and all  $t_i$  are even and strictly negative, then  $\text{star}(c; t_1, \dots, t_p)$  is very strongly quasipositive.

**2.43 Theorem** If  $(\mathcal{T}, w)$  is such that

- (1) if  $u$  is a non-node then  $w(u) \neq 0$ , and
- (2) if  $v, v'$  are adjacent nodes, then  $w(v)$  or  $w(v')$  is non-zero,

then  $(\mathcal{T}, w)$  is positive if and only if the stick of every non-node in  $(\mathcal{T}, w)$  and the star of every node in  $(\mathcal{T}, w)$  is positive.

**Proof** Unless  $n = 0$ , exactly one projective orientation of the canonical 2-string tangle depicted in Figure 6(d) makes all  $|n|$  crossings positive. (1) and (2) ensure that the positive sticks and stars fit together consistently at the appropriate twigs of each.  $\square$

**2.44 Remark** (1) can be weakened but not dispensed with entirely; see Figure 10.

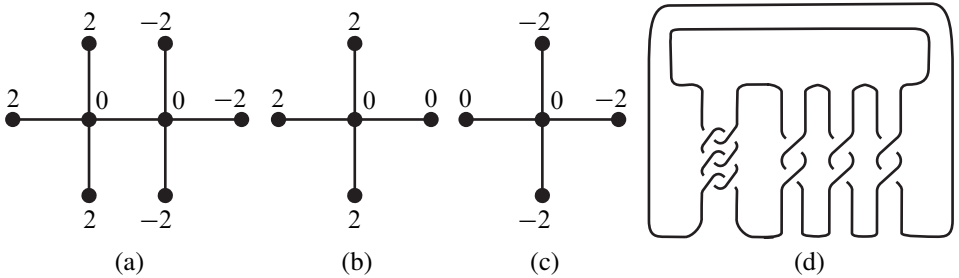

Figure 10: The weighted tree  $(\mathcal{T}, w)$  in (a) has no sticks and two stars, shown in (b) and (c). Both stars are positive; but the canonical arborescent link diagram of  $(\partial \text{sp}(\mathcal{T}, w), S^3)$ , shown in (d), has no projective orientation making it a positive diagram.

**2.45 Theorem** The following are equivalent.

- (A)  $(\mathcal{T}, w)$  is very strongly quasipositive.
- (B) The stick of every non-node in  $(\mathcal{T}, w)$  and the star of every node in  $(\mathcal{T}, w)$  is very strongly positive.
- (C) For every  $v \in V(\mathcal{T})$ ,  $w(v)$  is even and strictly negative.

**Proof** Immediate from Lemma 2.42(2), Lemma 2.42(6), and Theorem 2.15.  $\square$

Theorem 2.43 and, especially, Theorem 2.45, give an adequate account of strongly quasipositive arborescent links that are constructed from either positive weighted trees or very strongly quasipositive weighted trees. The situation is less satisfactory for strongly quasipositive arborescent links that are of neither of those types: the sufficient conditions to be described shortly are by no means clearly necessary.

Let  $S_0$ ,  $S'_0$ , and  $S_1$  be compact 2-submanifolds-with-boundary of  $S^3$  with  $S_0$  unoriented and  $\partial S_0 = \partial S'_0$  as unoriented 1-manifolds; either or both of  $S'_0$  and  $S_1$  may be oriented (if orientable). Let  $P_0 \subset S_0$  and  $P_1 \subset S_1$  be  $2p$ -gonal plumbing patches.

**2.46 Definition**  $P_0$  can be *transplanted* to a  $2p$ -gonal plumbing patch  $P'_0 \subset S'_0$  in case there is an ambient isotopy between the 2-complexes  $\partial S_0 \cup P_0$  and  $\partial S'_0 \cup P'_0$  respecting the components of  $\partial S_0$  and  $\partial S'_0$  and some (equivalently, every) projective orientation of  $\partial S = \partial S'$ .

**2.47 Lemma** If  $P_0 \subset S_0$  can be transplanted to  $P'_0 \subset S'_0$ , then to any plumbing  $S_0 P_0 *_{P_1} S_1$  corresponds a plumbing  $S'_0 P'_0 *_{P_1} S_1$  such that  $\partial(S_0 P_0 *_{P_1} S_1)$  and  $\partial(S'_0 P'_0 *_{P_1} S_1)$  are ambient isotopic by an isotopy respecting any pre-assigned orientations of  $\partial(S_0) = \partial(S'_0)$  and  $\partial(S_1)$  consistent with (say) the plumbing  $\partial(S_0 P_0 *_{P_1} S_1)$ .

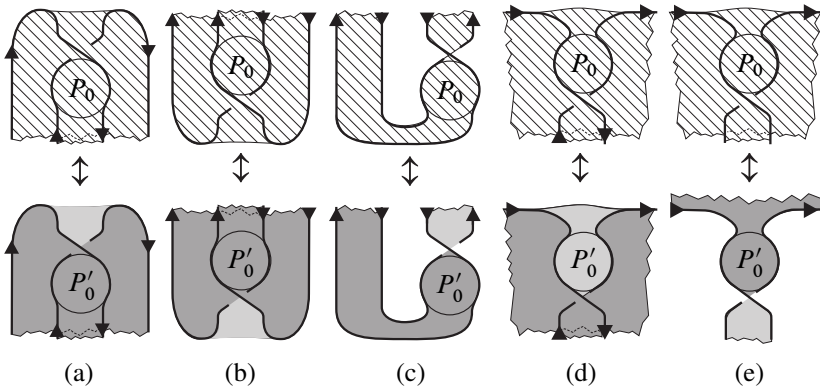

Figure 11: Transplanting a core-transverse plumbing patch from an unoriented strip-plumbed surface: the donor, which is  $\text{sp}(\text{stick}(r_1, \dots, r_n))$  in (a)–(c) and  $\text{sp}(\text{star}(0; t_1, \dots, t_p))$  in (d) and (e), may not be globally orientable (although the pictured part of it is); the recipient is a Seifert surface for the donor’s boundary with the indicated orientation in (a)–(d), and the pretzel surface  $\mathcal{P}(t_1, \dots, t_p)$  in (e), where nothing is oriented.

In all instances of transplanting used here,  $p = 2$ ; Figure 11 shows them as follows.

- (1) The upper portion of each sub-figure depicts part of one strip of an unoriented iterated strip-plumbed 2-manifold-with-boundary  $S_0$ .
  - (i) In (a),  $S_0 = \text{sp}(\text{stick}(r_1, \dots, r_n))$  and the strip is  $\mathcal{S}(\mathbb{C}, r_1) \subset S_0$ .
  - (ii) In (b) and (c),  $S_0 = \text{sp}(\text{stick}(r_1, \dots, r_n))$  and the strip is  $\mathcal{S}(\mathbb{C}, r_n) \subset S_0$ .
  - (iii) In (d) and (e),  $S_0 = \text{sp}(\text{star}(c; t_1, \dots, t_p))$  and the strip is any  $\mathcal{S}(\mathbb{C}, t_i) \subset S_0$ .
- (2) In each sub-figure  $P_0$  is a core-transverse plumbing patch on that strip, and  $\partial S_0$  is equipped with a projective orientation  $\mathfrak{o}$  making the visible crossing positive.
- (3) The lower portion of each sub-figure depicts part of the Seifert surface  $S'_0$  with  $\partial S'_0 = \partial S_0$  that is produced by applying Seifert's algorithm to a diagram of  $\partial S_0^\mathfrak{o}$  extending the partial diagram in the sub-figure.
- (4) In each sub-figure,  $P'_0$  is  $P_0$  transplanted from  $S_0$  to  $S'_0$  (the required isotopy can be taken to be constant).

Figure 12 illustrates Lemma 2.47 using the surfaces in Figure 11(c) and (d).

Note that in the cases illustrated in Figure 11(a)–(d), the unique projective orientation of  $\partial P_0$  is consistent with the given projective orientation of  $\partial S_0$ . Contrariwise, in the remaining cases of first and last strips on  $\text{sp}(\text{stick}(r_1, \dots, r_n))$  and any strip  $\mathcal{S}(\mathbb{C}, t_i)$  on  $\text{sp}(\text{star}(0; t_1, \dots, t_p))$ , with boundaries oriented to make the visible crossing positive, these projective orientations are inconsistent, and thus a core-transverse plumbing patch  $P_0$  on that strip *cannot* be transplanted to a plumbing patch on  $S'_0$  (by any isotopy whatever); see Figure 13.

**2.48 Proposition** *Let  $r_1, \dots, r_n, t_1, \dots, t_p$ , and  $c$  be integers.*

- (A) *Let  $S_0 = \text{sp}(\text{stick}(r_1, \dots, r_n))$ . If  $\partial S_0$  has a projective orientation  $\mathfrak{o}$  for which  $((\partial S_0)^\mathfrak{o}, S^3)$  is a positive link,  $S'_0$  is the quasipositive Seifert surface with  $\partial S'_0 = (\partial S_0)^\mathfrak{o}$  produced by Seifert's algorithm (see Theorem 2.17), and  $i = 1$  or  $i = n$ , then a core-transverse 4-patch  $P_0 \subset \mathcal{S}(\mathbb{C}, r_i) \subset S_0$  can be transplanted to  $S'_0$  if and only if  $r_i < 0$ .*
- (B) *Let  $S_0 := \text{sp}(\text{star}(c; t_1, \dots, t_p))$ . If  $\partial S_0$  has a projective orientation  $\mathfrak{o}$  for which  $((\partial S_0)^\mathfrak{o}, S^3)$  is a positive link,  $S'_0$  is the quasipositive Seifert surface with  $\partial S'_0 = (\partial S_0)^\mathfrak{o}$  produced by Seifert's algorithm, and  $1 \leq i \leq p$ , then a core-transverse 4-patch  $P_0 \subset \mathcal{S}(\mathbb{C}, t_i) \subset S_0$  can be transplanted to  $S'_0$  if and only if  $t_i < 0$ .*
- (C) *If  $c = 0$ , all  $t_i$  have the same parity,  $t_i + t_j < 0$  for  $1 \leq i < j \leq p$ , and  $1 \leq i \leq p$ , then a core-transverse 4-patch  $P_0 \subset \mathcal{S}(\mathbb{C}, t_i) \subset S_0$  can be transplanted to  $S'_0$ .*

**Proof** (A) follows from Proposition 2.32 applied to Figure 11(a)–(c), (B) from Proposition 2.38 applied to Figure 11(d), and (C) from Proposition 2.37(2) applied to Figure 11(e).  $\square$

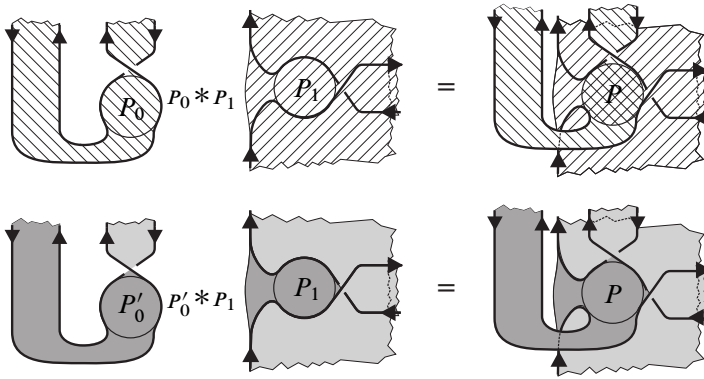

Figure 12: Plumbing along transplanted plumbing patches

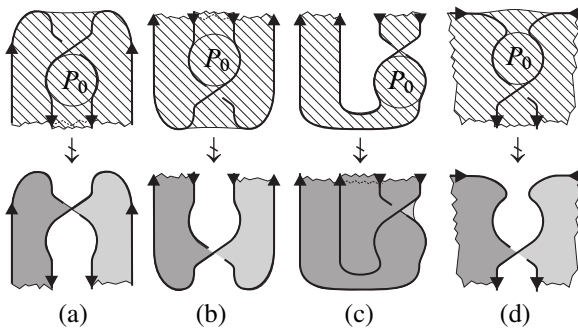

Figure 13: The indicated core-transverse plumbing patches on strip-plumbed surfaces cannot be transplanted to the indicated Seifert surfaces bounded by the same links.

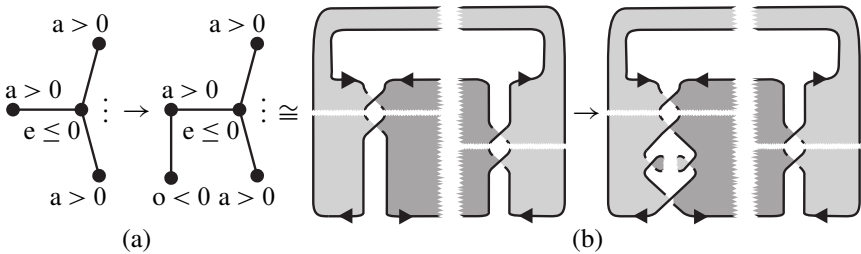

Figure 14: The illustrated strip-plumbing preserves diagrammatic positivity and therefore strong quasipositivity, but cannot be performed by plumbing quasipositive Seifert surfaces.



**2.49 Remark** As suggested by Figure 14, many arborescent links have positive (and thus strongly quasipositive) orientations but are not plumbed from strongly quasipositive sticks and stars as in Theorem 2.43. It would be interesting to have necessary and sufficient conditions for an arborescent link to have a (strongly) quasipositive orientation.

### 3 Constructions of 3–dimensional transverse $\mathbb{C}$ –links

This part collects constructions of 3–dimensional transverse  $\mathbb{C}$ –links; many of the constructions use quasipositive links constructed in Section 2.

**3.1 Notation** Let  $\Delta \subset U \subset \mathbb{C}^2$ ,  $\Sigma = \partial\Delta$ , and  $f \in \mathcal{O}(U)$  be as in Section 1.

- (1) For  $r > \max\{|f(z)| : z \in \Delta\}$ , the product  $\Delta \times D^2(0, r) \subset U \times \mathbb{C} \subset \mathbb{C}^3$  is a closed Stein 6–disk. Its boundary  $\partial(\Delta \times D^2(0, r)) = \Sigma \times D^2(0, r) \cup \Delta \times S^1(0, r)$ , a piecewise real-analytic 5–sphere, is pseudoconvex but not strictly so; however,  $\Delta \times D^2(0, r)$  can be arbitrarily well approximated by closed Stein 6–disks in  $U \times \mathbb{C}$  with strictly pseudoconvex real-analytic boundaries. Write  $\Delta^\otimes$  for such an approximation that is sufficiently close for whatever purpose is required, and  $\Sigma^\otimes$  for  $\partial\Delta^\otimes$ .
- (2) For an integer  $q > 0$ , define  $f \otimes [q]$  by  $(f \otimes [q])(z_0, z_1, z_2) = f(z_0, z_1) + z_2^q$ ; define  $f \otimes [0]$  by  $(f \otimes [0])(z_0, z_1, z_2) = f(z_0, z_1)$ . For a 1–dimensional transverse  $\mathbb{C}$ –link  $\mathcal{L}(f, \Sigma)$ , write  $\mathcal{L}(f, \Sigma) \otimes [q] := (V(f \otimes [q]), \Sigma^\otimes)$ ; for  $q > 0$ , this is an instance of what Kauffman and Neumann [45] call the  $q$ –fold cyclic suspension  $\mathcal{L} \otimes [q]$  of a smooth, oriented link  $\mathcal{L}$ .

#### 3.1 3–dimensional links of isolated singular points

This heading is included for completeness only, since the theory of these 3–dimensional transverse  $\mathbb{C}$ –links has been thoroughly developed ([52; 58; 18] etc).

#### 3.2 Adding a dummy variable

**3.2 Proposition** If  $\mathcal{L}(f, \Sigma)$  is a 1–dimensional transverse  $\mathbb{C}$ –link with non-singular  $\mathbb{C}$ –span  $S(f, \Sigma)$ , then:

- (1)  $\mathcal{L}(f, \Sigma) \otimes [0] = \mathcal{L}(f \otimes [0], \Sigma^\otimes)$  is a transverse 3–dimensional  $\mathbb{C}$ –link.
- (2)  $S(f \otimes [0], \Delta^\otimes)$  is non-singular, and diffeomorphic to a disjoint union of boundary-connected sums of copies of  $S^1 \times D^3$ .
- (3)  $L(f \otimes [0], \Sigma^\otimes)$  is diffeomorphic to a disjoint union of connected sums of copies of  $S^1 \times S^2$ .

**Proof** Both (1) and (3) follow from (2). To see (2), note that the 2–manifold-with-boundary  $S(f, \Delta)$  has a handle decomposition into 2–dimensional 0–handles and 1–handles attached orientably to the 0–handles; therefore the product  $S(f, \Delta) \times D^2$  (with corners smoothed) has a handle decomposition into 4–dimensional 0–handles and 1–handles attached orientably to the 0–handles, and so must be as described.  $\square$

**Proposition 3.2** yields particularly interesting examples in case  $S(f, \Delta)$  is a 2–disk, so that  $\mathcal{L}(f, \Sigma)$  is a slice knot (in fact a ribbon knot; cf [67]).

**3.3 Proposition** *If  $\mathcal{L}(f, S^3)$  is a quasipositive slice knot, then the 3–dimensional transverse  $\mathbb{C}$ –link  $\mathcal{L}(f \otimes [0], S^{3 \otimes})$  is a slice knot in the 5–sphere  $S^{3 \otimes}$ .*

**3.4 Questions** There are infinitely many pairwise non-isotopic quasipositive slice knots in  $S^3$  (indeed, there are infinitely many of braid index 3).

- (1) Are there infinitely many pairwise non-isotopic slice 3–dimensional transverse  $\mathbb{C}$ –links in  $S^5$ ?
- (2) Specifically, if  $\mathcal{L}(f_0, S^3)$  and  $\mathcal{L}(f_1, S^3)$  are non-isotopic quasipositive slice knots in  $S^3$ , are the 3–dimensional transverse  $\mathbb{C}$ –links  $\mathcal{L}(f \otimes [0], S^{3 \otimes})$  non-isotopic?

### 3.3 General cyclic branched covers of $S^3$ over quasipositive links

The  $q$ –fold cyclic suspension  $\mathcal{L} \otimes [q]$  of a link  $\mathcal{L} = (L, S^m)$ , introduced by Neumann [57] and Kauffman and Neumann [45], was defined in **Notation 3.1(2)** in the special case that  $\mathcal{L} = \mathcal{L}(f, S^3)$  is a 1–dimensional transverse  $\mathbb{C}$ –link. Cyclic suspensions of arbitrary links are themselves special cases of what Kauffman [44] and Kauffman and Neumann [45] call the *knot product*  $\mathcal{K} \otimes \mathcal{L}$  of links  $\mathcal{K}$  and  $\mathcal{L}$ . In a general knot product  $\mathcal{K} \otimes \mathcal{L}$ ,  $\mathcal{K} = (K, S^k)$  is any smooth, oriented  $(k - 2)$ –dimensional link,  $\mathcal{L} = (L, S^\ell)$  is a fibered smooth, oriented  $(\ell - 2)$ –dimensional link, and  $\mathcal{K} \otimes \mathcal{L}$  is a smooth, oriented  $(k + \ell - 1)$ –dimensional link  $(K \otimes L, S^{k+\ell+1})$ .

**3.5 Theorem** (Kauffman and Neumann [45]) (1) *The link-manifold of the  $q$ –fold cyclic suspension of  $\mathcal{L} \otimes [q]$  of a link  $\mathcal{L} = (L, S^m)$  is the  $q$ –fold cyclic branched cover of  $S^m$  branched along  $L$ .*

- (2) *If both  $\mathcal{K}$  and  $\mathcal{L}$  are fibered, then so is  $\mathcal{K} \otimes \mathcal{L}$ ; in particular, the  $q$ –fold cyclic suspension of a fibered link is fibered.*

Whatever is not obvious in the next proposition follows directly from **Theorem 3.5**.

### 3.6 Proposition

Let  $q \geq 1$ .

(A) If  $\mathcal{L}(f, S^3)$  is a 1-dimensional transverse  $\mathbb{C}$ -link, then:

- (1) Its  $q$ -fold cyclic suspension  $\mathcal{L}(f, S^3) \otimes [q] = \mathcal{L}(f \otimes [q], S^{3 \otimes})$  is a 3-dimensional transverse  $\mathbb{C}$ -link.
- (2) The link-manifold  $L(f \otimes [q], S^{3 \otimes})$  is the  $q$ -fold cyclic branched cover of  $S^3$  branched along  $L(f, S^3)$ .
- (3) The  $\mathbb{C}$ -span  $S(f \otimes [q], D^{4 \otimes})$  is the  $q$ -fold cyclic branched cover of  $D^4$  branched along  $S(f, D^4)$ .

(B) If in addition  $\mathcal{L}(f, S^3)$  is

- (1) fibered,
- (2) the link of an isolated singular point, or
- (3) the link at infinity of a polynomial,

then  $\mathcal{L}(f \otimes [q], S^{3 \otimes})$  is of the same type.

**3.7 Remark** Let  $M$  be the  $q$ -fold cyclic branched cover of  $S^3$  branched along a quasipositive link. Harvey, Kawamuro, and Plamenevskaya [38] have used contact topology to find a Stein-fillable contact structure  $\xi$  on  $M$ . Proposition 3.6(A)(2), together with the fact about Stein fillings noted just after Theorem 2.5, gives the (apparently) stronger conclusion that  $\xi$  can be required to have a Stein filling by a Stein domain on a complex algebraic surface in  $\mathbb{C}^3$ .

### 3.4 Double branched covers of $S^3$ over quasipositive links

It is traditional to call 2-fold branched covers *double* branched covers. Double branched covers have two useful properties that distinguish them among all cyclic branched covers of classical links.

**3.8 Theorem** If  $\mathcal{L} = (L, S^3)$  is an oriented classical link, then the double cover of  $S^3$  branched over  $L$  is invariant under both changes of orientation of  $\mathcal{L}$  and mutation of  $\mathcal{L}$ .

Here a *mutation* is the composition of finitely many *elementary mutations* as depicted and described (for unoriented links, their appropriate setting in this context) in Figure 15.

**Proof** Invariance under changes of orientation is trivial (and vacuously so in case  $\mathcal{L}$  is a knot); invariance under mutation was proved by Montesinos [53] and Viro [92].  $\square$

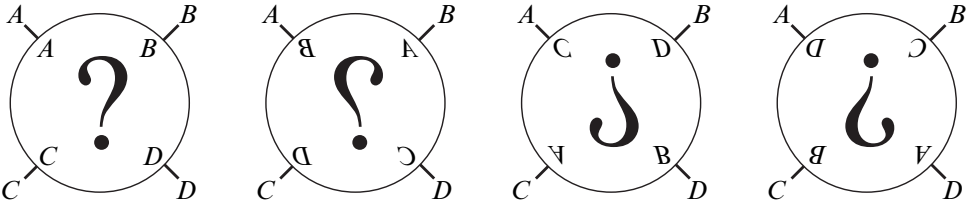

Figure 15: Part of a diagram for an unoriented classical link-manifold  $L$  is shown schematically at the left; the question mark stands for an arbitrary tangle with four endpoints  $A, \dots, D$  (its two strings may be knotted, and it may have simple closed curve components). By leaving alone what is not shown while replacing the shown piece with one of its three transforms (at the right), the original diagram is transformed into a diagram of an *elementary mutation* of  $L$ .

**3.9 Remark** The operation of mutation was introduced explicitly for link diagrams by Conway [17] and explicitly for links themselves by Montesinos and Viro, but none of [17; 92; 53] contains the term “mutation”; I do not know when (and by whom) that word was first used, and would welcome information on the topic.

**3.4.1 Doubles of knot exteriors** For any manifold-with-boundary  $M$ , the *double* of  $M$  is the (suitably smoothed) identification space  $M \times \{0, 1\} / \sim$ , where the non-trivial equivalence classes of the equivalence relation  $\sim$  are precisely the pairs  $\{(x, 0), (x, 1)\}$  with  $x \in \partial M$ .

**3.10 Lemma** If  $\mathcal{K}$  is a classical knot, then the double cover of  $S^3$  branched over  $|\mathcal{K}\{2, 0\}| = |\mathcal{A}(\mathcal{K}, 0)|$  is diffeomorphic to the double of the exterior  $E(\mathcal{K})$  of  $\mathcal{K}$ .

**3.11 Proposition** If either

- (a)  $\mathcal{K}$  is quasipositive or
- (b) the maximal Thurston–Bennequin invariant  $TB(\mathcal{K})$  of  $\mathcal{K}$  is non-negative,

then the double of  $E(\mathcal{K})$  occurs as the link-manifold of a 3-dimensional transverse  $\mathbb{C}$ -link  $\mathcal{L}(f, \Sigma^5)$ .

**Proof** In case (a) the conclusion follows from Proposition 2.11 (with  $n = 2$ ) and Proposition 3.6 (with  $q = 2$ ); in case (b) the conclusion follows from Theorem 2.14 and Proposition 3.6 (with  $q = 2$ ).  $\square$

**3.12 Remarks** (1) If the quasipositive knot  $\mathcal{K}$  is a transverse  $\mathbb{C}$ -link with non-singular  $\mathbb{C}$ -span  $S$ , then by the proof of [Proposition 2.11](#) the  $\mathbb{C}$ -span of  $\mathcal{K}\{2, 0\}$  can be taken to be two parallel copies of  $S$ . In this case, [Proposition 3.6\(3\)](#) implies that the  $\mathbb{C}$ -span of the 3-dimensional transverse  $\mathbb{C}$ -link  $\mathcal{L}(f, \Sigma^5)$  in [Proposition 3.11](#) has Euler characteristic  $2 - \chi(S)$ .

(2) If the annulus  $\mathcal{A}(\mathcal{K}, 0)$  is a quasipositive Seifert surface, and the  $\mathbb{C}$ -span of the strongly quasipositive link  $(\partial\mathcal{A}(\mathcal{K}, 0), S^3)$  is non-singular (which may be assumed), then that  $\mathbb{C}$ -span is also an annulus; in this case, the  $\mathbb{C}$ -span of the 3-dimensional transverse  $\mathbb{C}$ -link  $\mathcal{L}(f, \Sigma^5)$  in [Proposition 3.11](#) has Euler characteristic 2.

(3) Consequently, if  $\mathcal{K} \neq \mathbb{O}$  is strongly quasipositive, then the double of  $E(\mathcal{K})$  occurs as the link-manifold of two transverse  $\mathbb{C}$ -links in  $S^5$  with non-singular  $\mathbb{C}$ -spans that are not diffeomorphic to each other. In general the two links should not be expected to be ambient isotopic to each other.

**3.4.2 Seifert manifolds with base  $S^2$**  It is standard (see, eg, Bonahon and Siebenmann [\[12\]](#)) that a 3-manifold  $M$  is Seifert-fibered over  $S^2$  with at least 3 exceptional fibers if and only if  $M$  is the double branched cover of  $S^3$  branched over a pretzel link-manifold  $P(t_1, \dots, t_p)$  (the restriction on the number of exceptional fibers is an artifact of the definitional restriction on pretzel links that  $p$  be at least 3), and then (in the language of [\[12, page 323\]](#))  $(0; 1/t_1, \dots, 1/t_p)$  is the *raw data vector* of the Seifert manifold  $M$ .

**3.13 Lemma** *The pretzel link  $\mathfrak{P}(t_{\pi(1)}, \dots, t_{\pi(p)})$  is a mutation of  $\mathfrak{P}(t_1, \dots, t_p)$  for any permutation  $\pi$  of  $\{1, \dots, p\}$ .*

By [Theorem 3.8](#) and [Lemma 3.13](#), in the description of  $M$  as the double branched cover of  $S^3$  over  $P(t_1, \dots, t_p)$  no generality is lost by requiring

$$(3-1) \quad p = q + r + s, \quad t_1, \dots, t_q > 1, \quad t_{q+1}, \dots, t_{q+r} < -1, \quad |t_{q+r+1}|, \dots, |t_p| = 1.$$

On assumption (3-1), the Seifert data vector of  $M$  (again following [\[12\]](#)) is

$$(0; -r; 1/t_1, \dots, 1/t_q, 1 + 1/t_{q+1}, \dots, 1 + 1/t_{q+r})$$

and  $M$  has the representation

$$(3-2) \quad M(\mathbb{O}, \mathbb{o}; 0; -r; (t_1, 1), \dots, (t_q, 1), (-t_{q+1}, -1-t_{q+1}), \dots, (-t_{q+r}, -1-t_{q+r}))$$

in (essentially) the original notation of Seifert [\[86\]](#).

Note that  $M$  does not depend on  $s$ , so that the double cover of  $S^3$  branched over

$$P(t_1, \dots, t_{q+r}, \overbrace{1, \dots, 1}^{s_+ \text{ times}}, \overbrace{-1, \dots, -1}^{s_- \text{ times}})$$

is independent of  $s_+$  and  $s_-$ , although (with trivial exceptions) the links corresponding to given values of  $s_+$  and  $s_-$  are ambient isotopic (and mutations of each other) if and only if they have the same value  $s_+ - s_-$ .

**3.14 Proposition** *If  $(t_1, \dots, t_p)$  is a  $p$ -tuple of integers satisfying (3-1), then the Seifert manifold (3-2) is the link-manifold of a 3-dimensional transverse  $\mathbb{C}$ -link in each of the following cases.*

- (A) All  $t_i$  are odd and negative.
- (B) No  $t_i$  is odd and negative, and an even number of  $t_i$  are positive.
- (C) All  $t_i$  are even, and  $t_i + t_j < 0$  for  $1 \leq i < j \leq p$ .
- (D)  $(t_1, \dots, t_p) = (2n + 1, -(2n + 1), -2m)$  for  $m, n > 0$ .

**Proof** (A) and (B) follow from Proposition 2.38, (C) from Proposition 2.37(1), and (D) from Questions 2.39(1), all upon passing to double covers of  $S^3$  branched over the relevant quasipositive links. □

Gompf [34] shows that if  $M$  is a Seifert manifold then  $M$ , at least one of  $M$ ,  $\text{Mir } M$  has a Stein filling. Proposition 3.14 allows one to find such fillings that lie on algebraic surfaces in  $\mathbb{C}^3$ , and to calculate knot-theoretical properties of transverse  $\mathbb{C}$ -links with  $M$  and/or  $\text{Mir } M$  as link-manifold.

**3.15 Example** (Boileau and Rudolph [10]) For positive  $\ell, m, n > 0$ , let  $\Sigma(\ell, m, n)$  denote the 3-dimensional Brieskorn manifold  $L_{(0,0,0)}(z_0^\ell + z_1^m + z_2^n)$ . A calculation following Neumann [56] shows that  $\Sigma(\ell, m, n)$  is the Seifert manifold fibered over  $S^2$  with three exceptional fibers with  $M(\text{O}, 0; 0; -r; (\ell, 1), (m, 1), (n, 1))$  as its Seifert notation. Suppose that  $\ell m + \ell n - mn = \varepsilon \in \{-1, 1\}$  and  $\ell \equiv 1 + \varepsilon \pmod{2}$ ; for instance,  $(\ell, m, n)$  could be  $(2t - 1, 2t + 1, 2t^2 - 1)$  or  $(2t, 2t + 1, 2t(2t + 1) + 1)$ . In this situation, Proposition 3.14 implies that both  $\Sigma(\ell, m, n)$  and  $\text{Mir } \Sigma(\ell, m, n)$  are link-manifolds of 3-dimensional transverse  $\mathbb{C}$ -links. (This example is due to Michel Boileau.)

**3.4.3 Lens spaces** It is standard (Schubert [83]; see Burde and Zieschang [14]) that a 3-manifold is a lens space (including  $S^1 \times S^2$ ) if and only if  $M$  is the double branched cover of  $S^3$  branched over a rational link-manifold  $R(r_1, r_2, \dots, r_n)$ , and then  $M = L(P, Q)$  where

$$\frac{P}{Q} := r_1 + \frac{1}{-r_2 + \frac{1}{\dots + \frac{1}{(-1)^{n-1}r_n}}}$$

and  $P > 0$  is relatively prime to  $Q$ . By Proposition 2.32 and Proposition 3.6, we have the following.

**3.16 Proposition** *With  $P, Q$  as above, if  $\sigma_2^{r_1}\sigma_3^{r_2}\sigma_3^{r_3}\dots\sigma_\ell^{r_n} \in B_4$  (with  $\ell$  equal to 3 or 2 according as  $n$  is even or odd) is generated by the labeled digraph in Figure 7, then  $L(P, Q)$  is the link-manifold of a 3-dimensional transverse  $\mathbb{C}$ -link.*

**3.17 Example** [10] If  $p, q > 1$  are odd integers, then the lens spaces  $L(pq + 1, p)$  and  $\text{Mir } L(pq + 1, p)$  both appear as link-manifolds of 3-dimensional transverse  $\mathbb{C}$ -links. (This example is due to Michel Boileau.)

**3.4.4 Tree-manifolds** Let  $(\mathcal{T}, w)$  be a weighted planar tree. The double cover  $M^3(\mathcal{T}, w)$  of  $S^3$  branched over the arborescent link  $(\partial^{\mathcal{T}, w})$  is called a *tree-manifold*; it is independent of the planar embedding of  $\mathcal{T}$ .

**3.18 Remark** Tree-manifolds are a special case of *graph-manifolds*. Graph-manifolds can be defined in various (not obviously equivalent) ways; they were named and first investigated in full generality by Waldhausen [93; 94]. Waldhausen’s work built on studies of tree-manifolds by Hirzebruch [41] and von Randow [65]. For them, the tree-manifold  $M^3(\mathcal{T}, w)$  arises as the boundary of a 4-manifold  $W^4(\mathcal{T}, w)$  constructed by 4-dimensional plumbing of disk bundles. Hirzebruch, Neumann, and Koh [42] give a further exposition of tree-manifolds from this viewpoint. Neumann [58] gives a calculus for plumbing trees that is simultaneously applicable to strip-plumbings  $\text{sp}(\mathcal{T}, w)$  of unoriented 2-submanifolds-with-boundary of  $S^3$ , disk-bundle plumbings  $W^4(\mathcal{T}, w)$ , and tree-manifolds  $M^3(\mathcal{T}, w) := \partial W^4(\mathcal{T}, w)$ .

**3.19 Proposition** *If  $(\mathcal{T}, w)$  is strongly quasipositive, then  $M^3(\mathcal{T}, w)$  is the link-manifold of a 3-dimensional transverse  $\mathbb{C}$ -link; if  $(\mathcal{T}, w)$  is very strongly quasipositive, then  $W^4(\mathcal{T}, w)$  is the  $\mathbb{C}$ -span of a 3-dimensional transverse  $\mathbb{C}$ -link.*

This is a considerable strengthening of the following result, stated without proof (and using slightly different language) by Boileau and Rudolph [10] in 1995.

**3.20 Corollary** *Let the weighted tree  $(\mathcal{T}, w)$  satisfy the following conditions.*

- (1) *If  $v \in V(\mathcal{T})$  is neither a node nor adjacent to a node, then  $w(v)$  is even and less than 0.*
- (2) *If  $v \in V(\mathcal{T})$  is a node, then  $w(v)$  is even and not greater than 0.*
- (3) *Let  $v \in V(\mathcal{T})$  be a node with adjacent vertices  $v'_i, 1 \leq i \leq r$ .*
  - (a) *If  $w(v) < 0$ , then  $w(v_i)$  is even and less than 0,  $1 \leq i \leq r$ .*
  - (b) *If  $w(v) = 0$ , then  $v$  is distant from every other node, and  $w(v_i) + w(v_j)$  is even and less than 0,  $1 \leq i < j \leq r$ .*

*Then there is a projective orientation of the arborescent link  $(\partial \text{sp}(\mathcal{T}, w), S^3)$  that makes it a quasipositive link.*

### 3.5 3–dimensional links at infinity of complex surfaces

Using algebraic topology, Sullivan [90] proved that the link-manifold  $M$  of an isolated singular point of a complex algebraic surface in  $\mathbb{C}^3$  (actually, and more generally, the link—in the older sense of combinatorial topology, not that of knot-theory—of an isolated singular point of a complex algebraic surface in any  $\mathbb{C}^n$ ) cannot be diffeomorphic to the 3–torus  $(S^1)^3$ . On the other hand, if  $f(z_0, z_1, z_2) = z_0 z_1 z_2 - 1$ , then  $\mathcal{L}_\infty(f)$  has link-manifold diffeomorphic to  $(S^1)^3$  and  $\mathbb{C}$ –span diffeomorphic to  $(S^1)^2 \times D^2$ ; the proof consists in observing that, for sufficiently small  $r > 0$ ,  $(S^1)^2$  acts freely on

$$\{(z_0, z_1, z_2) \in \mathbb{C}^3 : f(z_0, z_1, z_2) = 0, z_0^2 + z_1^2 + z_2^2 \leq 1/r^2\}$$

by  $(e^{i\theta}, e^{i\varphi}) \cdot (z_0, z_1, z_2) = (e^{i\theta} z_0, e^{i\varphi} z_1, e^{-i(\theta+\varphi)} z_2)$ , and the slice

$$\{(x_0, x_1, x_2) \in \mathbb{R}_+^3 : f(x_0, x_1, x_2) = 0, x_0^2 + x_1^2 + x_2^2 \leq 1/r^2\}$$

of this action is diffeomorphic to  $D^2$ .

In fact, all the products  $S^1 \times F_g$  (where  $F_g$  is the closed orientable 2–manifold of genus  $g$ ) arise as link-manifolds of links at infinity: for sufficiently small  $\varepsilon > 0$ ,  $\{(z_0, z_1, z_2) \in \mathbb{C}^3 : z_0 z_1 (z_2^g - 1) = 1, |z_0|^2 + |z_1|^2 + |z_2 x_i|^2 = 1/\varepsilon\}$  is diffeomorphic to  $S^1 \times F_g$  (Boileau and Rudolph [10]).



## Acknowledgments

Many thanks to R İnanc Baykur, John Etnyre, and Ursula Hamenstädt, the organizers of the conference on “Interactions between low dimensional topology and mapping class groups” (MPI–Bonn, July 2013), for their invitation to speak there and to contribute to this volume. I also thank an anonymous referee for a close reading and numerous helpful suggestions, including references that I had overlooked. Preliminary versions of some results in part [Section 3](#), particularly portions of [Sections 3.4.2–3.4.4](#) and [Section 3.5](#), were discovered in collaboration with Michel Boileau; I am very grateful for that collaboration, and assume all responsibility for our failure (so far) to publish a final version of [\[10\]](#).

## References

- [1] **S Akbulut, B Ozbagci**, *Lefschetz fibrations on compact Stein surfaces*, Geom. Topol. 5 (2001) 319–334 [MR1825664](#)
- [2] **S Baader, M Ishikawa**, *Legendrian graphs and quasipositive diagrams*, Ann. Fac. Sci. Toulouse Math. 18 (2009) 285–305 [MR2562830](#)
- [3] **S Baader, M Ishikawa**, *Legendrian framings for two-bridge links*, Proc. Amer. Math. Soc. 139 (2011) 4513–4520 [MR2823096](#)
- [4] **S Baader, F Kutzschebauch, E F Wold**, *Knotted holomorphic discs in  $\mathbb{C}^2$* , J. Reine Angew. Math. 648 (2010) 69–73 [MR2774305](#)
- [5] **D Bennequin**, *Entrelacements et équations de Pfaff*, from: “Third Schnepfenried geometry conference, Vol. 1”, Astérisque 107, Soc. Math. France, Paris (1983) 87–161 [MR753131](#)
- [6] **J S Birman**, *Braids, links, and mapping class groups*, Annals of Mathematics Studies 82, Princeton Univ. Press (1974) [MR0375281](#)
- [7] **J S Birman, T E Brendle**, *Braids: A survey*, from: “Handbook of knot theory”, (W Menasco, M Thistlethwaite, editors), Elsevier, Amsterdam (2005) 19–103 [MR2179260](#)
- [8] **J Birman, K H Ko, S J Lee**, *A new approach to the word and conjugacy problems in the braid groups*, Adv. Math. 139 (1998) 322–353 [MR1654165](#)
- [9] **M Boileau, S Orevkov**, *Quasi-positivité d’une courbe analytique dans une boule pseudo-convexe*, C. R. Acad. Sci. Paris Sér. I Math. 332 (2001) 825–830 [MR1836094](#)
- [10] **M Boileau, L Rudolph**,  *$\mathbb{C}^3$ –algebraic Stein fillings via branched covers and plumbing* (1995) preprint
- [11] **F Bonahon, L C Siebenmann**, *Les nœuds algébriques* (1979) unpublished document

- [12] **F Bonahon, L C Siebenmann**, *New geometric splittings of classical knots and the classification and symmetries of arborescent knots* (2010) preprint, 30<sup>th</sup> year edition Available at <http://www-bcf.usc.edu/~fbonahon/Research/Preprints/BonSieb.pdf>
- [13] **K Brauner**, *Das Verhalten der Funktionen in der Umgebung ihrer Verzweigungsstellen*, Abh. Math. Sem. Univ. Hamburg 6 (1928) 1–55 [MR3069487](#)
- [14] **G Burde, H Zieschang**, *Knots*, Studies in Mathematics 5, de Gruyter, Berlin (1985) [MR808776](#)
- [15] **O Chisini**, *Una suggestiva rappresentazione reale per le curve algebriche piane*, Ist. Lombardo Sci. Lett. Rend. Cl. Sci. Mat. Nat. 66 (1933) 1141–1155
- [16] **O Chisini**, *Forme canoniche per il fascio caratteristico rappresentativo di una curva algebrica piana*, R. Ist. Lombardo Sci. Lett. Rend. Cl. Sci. Mat. Nat. 70 (1937) 49–61
- [17] **J H Conway**, *An enumeration of knots and links, and some of their algebraic properties*, from: “Computational Problems in Abstract Algebra”, Pergamon, Oxford (1970) 329–358 [MR0258014](#)
- [18] **D Eisenbud, W Neumann**, *Three-dimensional link theory and invariants of plane curve singularities*, Annals of Mathematics Studies 110, Princeton Uni. Press (1985) [MR817982](#)
- [19] **Y Eliashberg**, *Filling by holomorphic discs and its applications*, from: “Geometry of low-dimensional manifolds, 2”, (S K Donaldson, C B Thomas, editors), London Math. Soc. Lecture Note Ser. 151, Cambridge Univ. Press (1990) 45–67 [MR1171908](#)
- [20] **Y Eliashberg**, *Contact 3–manifolds twenty years since J Martinet’s work*, Ann. Inst. Fourier (Grenoble) 42 (1992) 165–192 [MR1162559](#)
- [21] **Y Eliashberg, M Gromov**, *Convex symplectic manifolds*, from: “Several complex variables and complex geometry, Part 2”, (E Bedford, J P D’Angelo, R E Greene, S G Krantz, editors), Proc. Sympos. Pure Math. 52, Amer. Math. Soc. (1991) 135–162 [MR1128541](#)
- [22] **Y Eliashberg, M Gromov**, *Embeddings of Stein manifolds of dimension  $n$  into the affine space of dimension  $3n/2 + 1$* , Ann. of Math. 136 (1992) 123–135 [MR1173927](#)
- [23] **J B Etnyre**, *Review of “Compact Stein surfaces with boundary as branched covers of  $B^4$ ”* (2002)
- [24] **J B Etnyre**, *Lectures on open book decompositions and contact structures*, from: “Floer homology, gauge theory, and low-dimensional topology”, (D A Ellwood, P S Ozsváth, A I Stipsicz, Z Szabó, editors), Clay Math. Proc. 5, Amer. Math. Soc. (2006) 103–141 [MR2249250](#)
- [25] **O Forster**, *Plongements des variétés de Stein*, Comment. Math. Helv. 45 (1970) 170–184 [MR0269880](#)

- [26] **R Furihata, M Hirasawa, T Kobayashi**, *Seifert surfaces in open books, and a new coding algorithm for links*, Bull. Lond. Math. Soc. 40 (2008) 405–414 [MR2418796](#)
- [27] **D Gabai**, *The Murasugi sum is a natural geometric operation*, from: “Low-dimensional topology”, (S J Lomonaco, Jr, editor), Contemp. Math. 20, Amer. Math. Soc. (1983) 131–143 [MR718138](#)
- [28] **D Gabai**, *The Murasugi sum is a natural geometric operation, II*, from: “Combinatorial methods in topology and algebraic geometry”, (J R Harper, R Mandelbaum, editors), Contemp. Math. 44, Amer. Math. Soc. (1985) 93–100 [MR813105](#)
- [29] **D Gabai**, *Genera of the arborescent links*, Mem. Amer. Math. Soc. 339, Amer. Math. Soc. (1986) [MR823442](#)
- [30] **H Geiges**, *An introduction to contact topology*, Cambridge Studies in Advanced Mathematics 109, Cambridge Univ. Press (2008) [MR2397738](#)
- [31] **A Geng**, *Two surfaces in  $D^4$  bounded by the same knot*, J. Symplectic Geom. 9 (2011) 119–122 [MR2811648](#)
- [32] **E Giroux**, *Géométrie de contact: de la dimension trois vers les dimensions supérieures*, from: “Proceedings of the International Congress of Mathematicians, Vol. II”, (T Li, editor), Higher Ed. Press, Beijing (2002) 405–414 [MR1957051](#)
- [33] **E Giroux, N Goodman**, *On the stable equivalence of open books in three-manifolds*, Geom. Topol. 10 (2006) 97–114 [MR2207791](#)
- [34] **RE Gompf**, *Handlebody construction of Stein surfaces*, Ann. of Math. 148 (1998) 619–693 [MR1668563](#)
- [35] **RE Gompf**, *Smooth embeddings with Stein surface images*, J. Topol. 6 (2013) 915–944 [MR3145144](#)
- [36] **ND Goodman**, *Contact structures and open books*, PhD thesis, University of Texas, Austin (2003) [MR2705496](#) Available at <http://search.proquest.com/docview/305307840>
- [37] **J Harer**, *How to construct all fibered knots and links*, Topology 21 (1982) 263–280 [MR649758](#)
- [38] **S Harvey, K Kawamuro, O Plamenevskaya**, *On transverse knots and branched covers*, Int. Math. Res. Not. 2009 (2009) 512–546 [MR2482123](#)
- [39] **M Haskins, N Kapouleas**, *Special Lagrangian cones with higher genus links*, Invent. Math. 167 (2007) 223–294 [MR2270454](#)
- [40] **M Hedden**, *An Ozsváth–Szabó Floer homology invariant of knots in a contact manifold*, Adv. Math. 219 (2008) 89–117 [MR2435421](#)
- [41] **F Hirzebruch**, *Über vierdimensionale Riemannsche Flächen mehrdeutiger analytischer Funktionen von zwei komplexen Veränderlichen*, Math. Ann. 126 (1953) 1–22 [MR0062842](#)

- [42] **F Hirzebruch, W D Neumann, S S Koh**, *Differentiable manifolds and quadratic forms*, Lecture Notes in Pure and Applied Mathematics 4, Marcel Dekker, New York (1971) [MR0341499](#)
- [43] **N Kasuya**, *The canonical contact structure on the link of a cusp singularity*, Tokyo J. Math. 37 (2014) 1–20 [MR3238328](#)
- [44] **L H Kauffman**, *Products of knots*, Bull. Amer. Math. Soc. 80 (1974) 1104–1107 [MR0362325](#)
- [45] **L H Kauffman, W D Neumann**, *Products of knots, branched fibrations and sums of singularities*, Topology 16 (1977) 369–393 [MR0488073](#)
- [46] **D Kim, Y S Kwon, J Lee**, *Banded surfaces, banded links, band indices and genera of links*, J. Knot Theory Ramifications 22 (2013) 1350035, 18 [MR3084753](#)
- [47] **P B Kronheimer, T S Mrowka**, *The genus of embedded surfaces in the projective plane*, Math. Res. Lett. 1 (1994) 797–808 [MR1306022](#)
- [48] **V S Kulikov, D Oru, V Shevchishin**, *Regular homotopy of Hurwitz curves*, Izv. Ross. Akad. Nauk Ser. Mat. 68 (2004) 91–114 [MR2069195](#)
- [49] **R A Litherland**, *Signatures of iterated torus knots*, from: “Topology of low-dimensional manifolds”, (R A Fenn, editor), Lecture Notes in Math. 722, Springer, Berlin (1979) 71–84 [MR547456](#)
- [50] **A Loi, R Piergallini**, *Compact Stein surfaces with boundary as branched covers of  $B^4$* , Invent. Math. 143 (2001) 325–348 [MR1835390](#)
- [51] **P M Melvin, H R Morton**, *Fibred knots of genus 2 formed by plumbing Hopf bands*, J. London Math. Soc. 34 (1986) 159–168 [MR859157](#)
- [52] **J Milnor**, *Singular points of complex hypersurfaces*, Annals of Mathematics Studies 61, Princeton Univ. Press (1968) [MR0239612](#)
- [53] **J M Montesinos**, *Seifert manifolds that are ramified two-sheeted cyclic coverings*, Bol. Soc. Mat. Mexicana 18 (1973) 1–32 [MR0341467](#)
- [54] **T Nakamura**, *Positive knots*, master’s thesis, Keio University (1998)
- [55] **T Nakamura**, *Four-genus and unknotting number of positive knots and links*, Osaka J. Math. 37 (2000) 441–451 [MR1772843](#)
- [56] **W D Neumann**,  *$S^1$ -actions and the  $\alpha$ -invariant of their involutions*, Bonn. Math. Schr. 44 (1970) 1–82 [MR0317346](#) PhD thesis
- [57] **W D Neumann**, *Cyclic suspension of knots and periodicity of signature for singularities*, Bull. Amer. Math. Soc. 80 (1974) 977–981 [MR0358797](#)
- [58] **W D Neumann**, *A calculus for plumbing applied to the topology of complex surface singularities and degenerating complex curves*, Trans. Amer. Math. Soc. 268 (1981) 299–344 [MR632532](#)

- [59] **W Neumann, L Rudolph**, *Unfoldings in knot theory*, Math. Ann. 278 (1987) 409–439 [MR909235](#)
- [60] **W D Neumann, L Rudolph**, *The enhanced Milnor number in higher dimensions*, from: “Differential topology”, (U Koschorke, editor), Lecture Notes in Math. 1350, Springer, Berlin (1988) 109–121 [MR979336](#)
- [61] **W D Neumann, L Rudolph**, *Difference index of vectorfields and the enhanced Milnor number*, Topology 29 (1990) 83–100 [MR1046626](#)
- [62] **L Neuwirth**, *The algebraic determination of the topological type of the complement of a knot*, Proc. Amer. Math. Soc. 12 (1961) 904–906 [MR0133817](#)
- [63] **L Neuwirth**, *On Stallings fibrations*, Proc. Amer. Math. Soc. 14 (1963) 380–381 [MR0149470](#)
- [64] **B Ozbagci, P Popescu-Pampu**, *Generalized plumbings and Murasugi sums*, preprint (2014) [arXiv:1412.2229](#)
- [65] **R von Randow**, *Zur Topologie von dreidimensionalen Baummannigfaltigkeiten*, Bonn. Math. Schr. No. 14 (1962) v+131 [MR0155304](#)
- [66] **L Rudolph**, *Embeddings of the line in the plane*, J. Reine Angew. Math. 337 (1982) 113–118 [MR676044](#)
- [67] **L Rudolph**, *Algebraic functions and closed braids*, Topology 22 (1983) 191–202 [MR683760](#)
- [68] **L Rudolph**, *Braided surfaces and Seifert ribbons for closed braids*, Comment. Math. Helv. 58 (1983) 1–37 [MR699004](#)
- [69] **L Rudolph**, *Constructions of quasipositive knots and links, I*, from: “Knots, braids and singularities”, (C Weber, editor), Monogr. Enseign. Math. 31, Enseignement Math., Geneva (1983) 233–245 [MR728589](#)
- [70] **L Rudolph**, *Constructions of quasipositive knots and links, II*, from: “Four-manifold theory”, (C Gordon, R Kirby, editors), Contemp. Math. 35, Amer. Math. Soc. (1984) 485–491 [MR780596](#)
- [71] **L Rudolph**, *Isolated critical points of mappings from  $\mathbf{R}^4$  to  $\mathbf{R}^2$  and a natural splitting of the Milnor number of a classical fibered link, I: Basic theory; examples*, Comment. Math. Helv. 62 (1987) 630–645 [MR920062](#)
- [72] **L Rudolph**, *Constructions of quasipositive knots and links, III: A characterization of quasipositive Seifert surfaces*, Topology 31 (1992) 231–237 [MR1167166](#)
- [73] **L Rudolph**, *Quasipositive annuli (Constructions of quasipositive knots and links, IV)*, J. Knot Theory Ramifications 1 (1992) 451–466 [MR1194997](#)
- [74] **L Rudolph**, *Totally tangential links of intersection of complex plane curves with round spheres*, from: “Topology ’90”, (B Apanasov, W D Neumann, A W Reid, L Siebenmann, editors), Ohio State Univ. MRSI 1, de Gruyter, Berlin (1992) 343–349 [MR1184419](#)

- [75] **L Rudolph**, *An obstruction to sliceness via contact geometry and “classical” gauge theory*, Invent. Math. 119 (1995) 155–163 [MR1309974](#)
- [76] **L Rudolph**, *Quasipositive plumbing (Constructions of quasipositive knots and links, V)*, Proc. Amer. Math. Soc. 126 (1998) 257–267 [MR1452826](#)
- [77] **L Rudolph**, *Positive links are strongly quasipositive*, from: “Proceedings of the Kirbyfest”, (J Hass, M Scharlemann, editors), Geom. Topol. Monogr. 2 (1999) 555–562 [MR1734423](#)
- [78] **L Rudolph**, *Hopf plumbing, arborescent Seifert surfaces, baskets, espaliers, and homogeneous braids*, Topology Appl. 116 (2001) 255–277 [MR1857666](#)
- [79] **L Rudolph**, *Quasipositive pretzels*, Topology Appl. 115 (2001) 115–123 [MR1840734](#)
- [80] **L Rudolph**, *Knot theory of complex plane curves*, from: “Handbook of knot theory”, (W Menasco, M Thistlethwaite, editors), Elsevier, Amsterdam (2005) 349–427 [MR2179266](#)
- [81] **M Sakuma**, *Minimal genus Seifert surfaces for special arborescent links*, Osaka J. Math. 31 (1994) 861–905 [MR1315011](#)
- [82] **H Schubert**, *Knoten und Vollringe*, Acta Math. 90 (1953) 131–286 [MR0072482](#)
- [83] **H Schubert**, *Knoten mit zwei Brücken*, Math. Z. 65 (1956) 133–170 [MR0082104](#)
- [84] **J Schürmann**, *Einbettungen Steinscher Räume in affine Räume minimaler Dimension*, PhD thesis, Universität Münster (1992)
- [85] **J Schürmann**, *Embeddings of Stein spaces into affine spaces of minimal dimension*, Math. Ann. 307 (1997) 381–399 [MR1437045](#)
- [86] **H Seifert**, *Topologie Dreidimensionaler Gefaserner Räume*, Acta Math. 60 (1933) 147–238 [MR1555366](#)
- [87] **H Seifert**, *Über das Geschlecht von Knoten*, Math. Ann. 110 (1935) 571–592 [MR1512955](#)
- [88] **J Stallings**, *On fibering certain 3–manifolds*, from: “Topology of 3–manifolds and related topics”, Prentice-Hall, Englewood Cliffs, NJ (1962) 95–100 [MR0158375](#)
- [89] **J R Stallings**, *Constructions of fibred knots and links*, from: “Algebraic and geometric topology, Part 2”, (R J Milgram, editor), Proc. Sympos. Pure Math. 32, Amer. Math. Soc. (1978) 55–60 [MR520522](#)
- [90] **D Sullivan**, *On the intersection ring of compact three manifolds*, Topology 14 (1975) 275–277 [MR0383415](#)
- [91] **W P Thurston**, **H E Winkelnkemper**, *On the existence of contact forms*, Proc. Amer. Math. Soc. 52 (1975) 345–347 [MR0375366](#)
- [92] **O J Viro**, *Nonprojecting isotopies and knots with homeomorphic coverings*, Zap. Nauč. Sem. Leningrad. Otdel. Mat. Inst. Steklov. (LOMI) 66 (1976) 133–147 [MR0451252](#)

- [93] **F Waldhausen**, *Eine Klasse von 3–dimensionalen Mannigfaltigkeiten, I*, Invent. Math. 3 (1967) 308–333 [MR0235576](#)
- [94] **F Waldhausen**, *Eine Klasse von 3–dimensionalen Mannigfaltigkeiten, II*, Invent. Math. 4 (1967) 87–117 [MR0235576](#)
- [95] **E Winkelnkemper**, *The history and applications of open books*, Springer, New York (1998) [MR1713074](#) Appendix to “High-dimensional knot theory: Algebraic surgery in codimension 2”

Mathematics and Computer Science, Clark University  
Worcester, MA 01610-1477, USA

[lrudolph@meganet.net](mailto:lrudolph@meganet.net)

Received: 19 August 2015

