

Pacific Journal of Mathematics

ROTATION SETS OF MAPS OF THE ANNULUS

FERNANDA MARIA BOTELHO

ROTATION SETS OF MAPS OF THE ANNULUS

F. BOTELHO

We study how the rotation interval of a point affects the rotation set of its ω -limit set. Similarities between rotation set and topological entropy were found, suggesting a deeper relation between these two concepts.

Introduction. In 1913 Birkhoff proved the first important theorem about twist maps of the annulus, initially conjectured by Poincaré and known as “*Poincaré’s last geometric theorem*”. It roughly says that any area preserving homeomorphism of the annulus which rotates the boundary components in opposite directions has at least two fixed points.

In [6] John Franks, using an extension of Poincaré’s definition of rotation number, proved that any chain transitive homeomorphism of the annulus that twists the boundaries in opposite directions has at least one fixed point; it follows from his work that if a homeomorphism of the annulus preserves area then either it has infinitely many periods or every point has the same rotation number.

In this paper we introduce the rotation set for an endomorphism of the annulus. Associated to each orbit we define a real sequence that measures the “wrapping” of the orbit around the inner boundary of the annulus. The limit of this sequence, if it exists, is called the *rotation number* of the orbit. If the limit does not exist, the set of all limit points of the referred sequence is a closed interval and designated *rotation interval* (see pg. 253). The rotation set is the union of all rotation intervals. It is a topologically invariant set that contains its supremum and infimum; however we don’t know if it is always closed.

There are interesting similarities between properties of the *rotation set* and *topological entropy*. Katok in [11] proved that any $C^{1+\varepsilon}$ diffeomorphism, f , with positive entropy has an invariant hyperbolic set Λ where f is topologically conjugate to a shift. This implies that either every point in Λ has the same rotation number or there is some point without rotation number. Nevertheless the relation between *positive entropy* and *existence of points without rotation number* is not completely understood.

1. Definitions and notations. We review the definition of rotation number of a point in the annulus under an endomorphism of degree 1.

Notation is fixed as follows:

- (a) $A = (\mathbf{R} \times I) / \sim$, where $I = [0, 1]$. For (s, t) and $(s', t) \in \mathbf{R} \times I$ we have $(s, t) \sim (s', t)$ iff $s - s' \in \mathbf{Z}$.
- (b) f is an endomorphism of degree 1 and F a lift to $\mathbf{R} \times I$.
- (c) $p: \mathbf{R} \times I \rightarrow A$ is a covering map and $x \in A, \bar{x} \in \mathbf{R} \times I$ with $p(\bar{x}) = x$.
- (d) \bar{x}_1, \bar{x}_2 are the projections of \bar{x} onto the first and second factors, respectively. $F_i^n(\bar{x}) = (F^n(\bar{x}))_i, i = 1, 2$.

DEFINITION. If the limit of $((F_1^n(\bar{x}) - \bar{x}_1)/n)_{n \geq 1}$ exists, it is denoted $\rho_f(x)$ (or $\rho(x)$) and said the *rotation number of x under f* , (rotation number is well defined up to an integer).

LEMMA 1.1. $((F_1^n(\bar{x}) - x_1)/n)_{n \geq 1}$ is uniformly bounded.

Proof. We note that $\Phi_1(y) = F_1(y) - y_1$ is translation invariant i.e., for any $y \in \mathbf{R} \times I$ we have $\Phi_1(y + (1, 0)) = \Phi_1(y)$.

Continuity of f assures the existence of

$$L = \max\{|\Phi_1(y)|, y \in \mathbf{R} \times I\} = \max\{|\Phi_1(y)|, y \in I^2\}.$$

Consequently we have:

$$\begin{aligned} \frac{|F_1^n(\bar{x}) - \bar{x}_1|}{n} &= \frac{\left| \sum_{j=0}^{n-1} [F_1(F^j(\bar{x})) - F_1^j(\bar{x})] \right|}{n} \\ &\leq \frac{\sum_{j=0}^{n-1} |F_1(F^j(\bar{x})) - F_1^j(\bar{x})|}{n} \leq L. \end{aligned} \quad \square$$

REMARK 1.2. Denoting

$$\begin{aligned} \iota: \mathbf{R} \times I &\rightarrow \mathbf{R} \times I && \text{then } F = \iota + \Phi, \\ (x, y) &\rightarrow (x, 0) \end{aligned}$$

where Φ is translation invariant. This leads to the Birkhoff sum

$$\frac{F_1^n(\bar{x}) - \bar{x}_1}{n} = \frac{\sum_{j=0}^{n-1} \Phi_1(F^j(\bar{x}))}{n}.$$

It follows from Birkhoff's ergodic theorem that the subset of A consisting of points without rotation number has measure zero.

Let Γ_a be the set of all limit points of $((F_1^n(\bar{a}) - \bar{a}_1)/n)_{n \geq 1}$, where $a \in A$. Then for all $n \in \mathbf{Z}, \Gamma_a = \Gamma_{f^n(a)}$.

LEMMA 1.3. Γ_a is a closed interval.

Proof. Assume that Γ_a is not an interval, and its complement contains $I_0 = (\alpha_1, \alpha_2)$, where $\alpha_1, \alpha_2 \in \Gamma_a$. Set $\delta = \alpha_2 - \alpha_1 > 0$. Let d be the usual metric in \mathbf{R} and

$$L = \max\{|\Phi_1(y)|, y \in \mathbf{R} \times I\}.$$

There exists i_0 such that for $i > i_0$

$$d\left(\frac{F_1^i(\bar{a}) - \bar{a}_1}{i}, \Gamma_a\right) < \frac{\delta}{8} \quad \text{and} \quad \frac{2L}{i_0} < \frac{\delta}{8}.$$

We choose $n > i_0$ so that:

$$\frac{F_1^n(\bar{a}) - \bar{a}_1}{n} < \alpha_1 + \frac{\delta}{8} \quad \text{and} \quad \frac{F_1^{n+1}(\bar{a}) - \bar{a}_1}{n+1} > \alpha_2 - \frac{\delta}{8}.$$

Hence the distance between these terms is bigger than $3\delta/4$.

On the other hand:

$$\begin{aligned} d\left(\frac{F_1^n(\bar{a}) - \bar{a}_1}{n}, \frac{F_1^{n+1}(\bar{a}) - \bar{a}_1}{n+1}\right) &= \frac{|nF_1^{n+1}(\bar{a}) - n\bar{a}_1 - (n+1)F_1^n(\bar{a}) + (n+1)\bar{a}_1|}{n(n+1)} \\ &\leq \frac{|F_1^{n+1}(\bar{a}) - F_1^n(\bar{a})|}{n+1} + \frac{|F_1^n(\bar{a}) - \bar{a}_1|}{(n+1)n} \leq \frac{L}{n+1} + \frac{L}{n+1} < \frac{\delta}{8}. \quad \square \end{aligned}$$

DEFINITION. Γ_a is the rotation interval associated with a .

If Λ is an f -invariant subset of A , the rotation set of f restricted to Λ , $R(f|_\Lambda)$, is the union $\bigcup_{\alpha \in \Lambda} \Gamma_a$. If $\Lambda = A$, $R(f|_\Lambda)$ is called the rotation set of f and denoted by $R(f)$.

Problem. Is $R(f)$ closed? (see Proposition 2.1, cf. [10]). (If $R(f)$ is finite then every point has rotation number.)

DEFINITION. The rotation function $\rho: A \rightarrow \mathbf{R}$ is defined by:

$$\forall x \in A \quad \rho(x) = \limsup \frac{F_1^n(\bar{x}) - \bar{x}_1}{n}.$$

It is easy to see that: (cf. [14])

- (i) ρ is measurable.
- (ii) ρ is continuous in a dense subset of A .
- (iii) ρ is Lebesgue measurable and $\int_A \rho = \lim_n \int (F_1^n(\bar{x}) - \bar{x}_1)/n \, dx$.
- (iv) For $\eta > 0$, there exists a closed set F such that $m(F) > m(A) - \eta$ and ρ is continuous in F (m is the Lebesgue measure).

2. Homeomorphisms of the annulus. The rotation number of a point is defined using the asymptotic average of the angular component of the forward orbit of a point. The ω -limit set is defined using the forward asymptotic behavior of a point. One would expect that if a point x has rotation number α then the rotation set of $\omega(x)$ is reduced to α . However this is not the case. There are examples (cf. pg. 262–263) of points with rotation number whose rotation set of the ω -limit set is nontrivial.

In this section we study the relationship between the rotation interval of a point and the rotation of its ω -limit set.

Let $\beta(x, \delta)$ be the ball of center x and radius δ .

PROPOSITION 2.1. *Let Λ be a compact f -invariant subset of A . $R(f|_\Lambda)$ contains its supremum and infimum.*

Proof. We start by noticing that Lemma 1.1 assures the existence of the infimum and supremum of $R(f|_\Lambda)$. Let $\alpha = \inf R(f|_\Lambda)$. We assume that $\alpha \notin R(f|_\Lambda)$. Then the following holds:

- (1) $d(\alpha, \Gamma_x) = \varepsilon_x > 0$, for all $x \in \Lambda$.
- (2) $\forall x \in \Lambda \exists n_x \in \mathbf{Z}^+$ and $\delta_x > 0$ such that

$$\frac{F_1^{n_x}(\bar{x}) - \bar{x}_1}{n_x} - \alpha > \frac{\varepsilon_x}{2} \quad \text{and} \quad \frac{F_1^{n_x}(\bar{y}) - \bar{y}_1}{n_x} - \alpha > \frac{\varepsilon_x}{2}, \quad \forall y \in \beta(x, \delta_x).$$

By compactness of $\Lambda \exists x_1, \dots, x_k \in \Lambda$ such that $\Lambda \subset \bigcup_{j=1}^k \beta(x_j, \delta_j)$ where $\delta_j = \delta_{x_j}$.

Setting $\varepsilon_0 = \min\{\varepsilon_1, \dots, \varepsilon_k\}$ and $n^* = \max\{n_1, \dots, n_k\}$ (for simpler notation we denote ε_j for ε_{x_j} and n_j for n_{x_j}), we choose $n_0 > n^*$ such that $n^*L/n_0 < \varepsilon_0/8$, where $L = \max\{|F_1(y) - y_1|, y \in \mathbf{R} \times I\}$.

Claim. $\forall n \geq n_0$ and $x \in \Lambda$

$$\frac{F_1^n(\bar{x}) - \bar{x}_1}{n} - \alpha > \frac{\varepsilon_0}{4}.$$

(This contradicts the infimum assumption for α .)

Proof of the claim. Let $n > n_0$ and $x \in \Lambda$. Then $x \in \beta(x_{i_1}, \delta_{i_1})$ for some $i_1 \leq k$. Condition (2) above can be written as follows

$$F_1^{n_{i_1}}(\bar{x}) - \bar{x}_1 - n_{i_1}\alpha > n_{i_1} \frac{\varepsilon_0}{2}.$$

Since $f^{n_{i_1}}(x) \in \Lambda$ one has

$$F_1^{n_{i_1} + n_{i_2}}(\bar{x}) - F_1^{n_{i_1}}(\bar{x}) - n_{i_2}\alpha > n_{i_2} \frac{\varepsilon_0}{2}$$

for some $i_2 \leq k$. Adding both inequalities, one gets

$$F_1^{n_{i_1}+n_{i_2}}(\bar{x}) - \bar{x}_1 - (n_{i_1} + n_{i_2})\alpha > (n_{i_1} + n_{i_2}) \cdot \frac{\epsilon_0}{2}.$$

This procedure is repeated until

$$s = n_{i_1} + \dots + n_{i_p} < n \leq n_{i_1} + \dots + n_{i_{(p+1)}}.$$

The following calculations are rather straightforward

$$F_1^s(\bar{x}) - \bar{x}_1 - s\alpha > s \frac{\epsilon_0}{2}.$$

Setting $n' = n - s$ it follows that $n' \leq n^*$. Hence

$$\begin{aligned} \frac{F_1^n(\bar{x}) - \bar{x}_1}{n} &= \frac{F_1^n(\bar{x}) - F_1^s(\bar{x})}{n} + \frac{F_1^s(\bar{x}) - \bar{x}_1}{s} \cdot \frac{s}{n} \\ &= \frac{F_1^n(\bar{x}) - F_1^s(\bar{x})}{n} + \frac{F_1^s(\bar{x}) - \bar{x}_1}{s} - \frac{F_1^s(\bar{x}) - \bar{x}_1}{s} \cdot \frac{n'}{n}. \end{aligned}$$

Since

$$\left| \frac{F_1^n(\bar{x}) - F_1^s(\bar{x})}{n} \right| \leq \frac{n'L}{n} \leq \frac{n^*L}{n} \leq \frac{\epsilon_0}{8}$$

and

$$\left| \frac{F_1^s(\bar{x}) - \bar{x}_1}{s} \cdot \frac{n'}{n} \right| \leq \frac{n'L}{n} < \frac{\epsilon_0}{8}$$

one has

$$\frac{F_1^n(\bar{x}) - \bar{x}_1}{n} - \alpha > \frac{F_1^s(\bar{x}) - \bar{x}_1}{s} - \alpha - \frac{\epsilon_0}{8} - \frac{\epsilon_0}{8} > \frac{\epsilon_0}{2} - \frac{\epsilon_0}{4} = \frac{\epsilon_0}{4}. \quad \square$$

REMARK. If Λ is some ω -limit set this proposition basically implies that $R(f|_\Lambda) \subset [\inf R(f|_\Lambda), \sup R(f|_\Lambda)]$. In the known examples where the inclusion is strict, there exists some point without rotation number. Does equality hold if we assume that every point has rotation number?

COROLLARY 2.2. *If $R(f|\omega(a)) = \{\alpha\}$ then a has rotation number and it equals α .*

Proof. Applying the proof of 2.1 to $\Lambda = \omega(a)$ we have that $\Gamma_a \subset [\inf R(f|\omega(a)), \sup R(f|\omega(a))]$. □

The corollary below is an easy consequence of a theorem by J. Franks which says that every point of an orientation preserving homeomorphism of the annulus with finitely many periods has rotation number. Furthermore if Λ is a compact, invariant and chain transitive subset of the annulus then $R(f|_\Lambda)$ is constant.

COROLLARY 2.3. *If f is a homeomorphism of A with finitely many periods then $R(f|\omega(a)) = \rho(a)$, for every $a \in A$.*

Proof. If f is orientation preserving, the result follows from Franks' theorem. Otherwise f^2 is orientation preserving. The proof follows from the next two lemmas since $R(f^2|\omega_{f^2}(a)) = \rho_{f^2}(a)$.

LEMMA. *The point $a \in A$ has rotation number under f iff it has rotation number under f^2 . If $\rho_f(a)$ exists then $\rho_f(a) = \rho_{f^2}(a)/2$.*

Proof.

$$\begin{aligned} & \left| \frac{F_1^{2n+1}(\bar{a}) - \bar{a}_1}{2n+1} - \frac{F_1^{2n}(\bar{a}) - \bar{a}_1}{2n} \right| \\ & \leq \left| \frac{F_1^{2n+1}(\bar{a}) - F_1^{2n}(\bar{a})}{2n+1} \right| + \left| \frac{F_1^{2n}(\bar{a}) - \bar{a}_1}{2n} \right| \frac{1}{2n+1} \\ & \leq \frac{L+L}{2n+1}, \quad \text{where } L = \max\{|F_1(y) - y_1|, y \in \mathbf{R} \times I\}. \end{aligned}$$

It follows that if $\rho_{f^2}(a)$ exists, so does $\rho_f(a)$ and $\rho_f(a) = \rho_{f^2}(a)/2$. \square

LEMMA. $R(f^2|\omega_{f^2}(a)) = 2 \cdot R(f|\omega_f(a))$.

Proof. Let $\alpha \in R(f^2|\omega_{f^2}(a))$. Choose $(n_i)_i$ and $x \in \omega_{f^2}(a)$ such that

$$\alpha = \lim_i \frac{F_1^{2n_i}(\bar{x})}{n_i} = 2 \lim_i \frac{F_1^{2n_i}(\bar{x})}{2n_i}.$$

Since $\lim_i F_1^{2n_i}(\bar{x})/2n_i \in R(f|\omega_f(a))$ we have proved that

$$R(f^2|\omega_{f^2}(a)) \subset 2 \cdot R(f|\omega_f(a)).$$

Now we show the other inclusion. Fix $\alpha \in R(f|\omega_f(a))$ and choose $(n_i)_i$ and $x \in \omega_f(a)$ such that $\alpha = \lim_i F_1^{n_i}(\bar{x})/n_i$. Assume $(n_i)_i$ has some subsequence constituted by even integers. Then $x \in \omega_{f^2}(a)$. Therefore $2\alpha \in R(f^2|\omega_{f^2}(a))$. If such sequence does not exist then

$$f(x) \in \omega_{f^2}(a) \quad \text{and} \quad \alpha = \lim_i \frac{F_1^{1+n_i}(\bar{x})}{1+n_i}.$$

Therefore $2\alpha \in R(f^2|\omega_{f^2}(a))$. \square

3. Properties of entropy and the rotation set. Both topological entropy and the rotation set *measure* the dynamics of an endomorphism. In this section we point out some similarities between these two concepts. We shall use the definition of entropy as presented by Bowen in [4].

Notation. $h(f)$ denotes the topological entropy of f .

We state below, without proof, some well known results concerning topological entropy [1]. We then state and prove the corresponding properties of the rotation set.

P1. Topological entropy and the rotation set are both topological invariants.

Proof. We show that $R(\psi f \psi^{-1}) = R(f)$, where ψ is some homeomorphism of A .

Set $\Psi = \iota + \eta$, where Ψ is a lift of ψ and $\iota(x, y) = (x, 0)$ for any $(x, y) \in \mathbf{R} \times I$, (note that η is translation invariant in the following sense: $\eta(x + 1, y) = \eta(x, y), \forall (x, y) \in \mathbf{R} \times I$).

For $\alpha \in R(f)$ we choose $x \in A$ and $(n_i)_i$ such that

$$\alpha = \lim_i \frac{F_1^{n_i}(\bar{x})}{n_i}.$$

Denoting $\bar{y} = \Psi(\bar{x})$ one has:

$$\begin{aligned} \alpha &= \lim_i \frac{F_1^{n_i}(\Psi^{-1}(\bar{y}))}{n_i} = \lim_i \frac{F_1^{n_i}(\Psi^{-1}(\bar{y})) + \eta_1(F_1^{n_i}(\Psi^{-1}(\bar{y})))}{n_i} \\ &= \lim_i \frac{\Psi_1 F^{n_i}(\Psi^{-1}(\bar{y}))}{n_i} \in R(\psi f \psi^{-1}). \end{aligned}$$

Since ψ is a homeomorphism the proof is completed. □

In fact the rotation set is invariant under semi-conjugacy i.e. given f and g , homeomorphisms of A we say that f is semi-conjugate to g if there exists ψ , continuous and onto so that the following diagram commutes:

$$\begin{array}{ccc} A & \xrightarrow{f} & A \\ \psi \downarrow & & \psi \downarrow \\ A & \xrightarrow{g} & A \end{array}$$

Under this assumption $R(f) = R(g)$. The proof is similar to the previous one. However M. Rees in [13] gave an example where topological entropy is not invariant under semi-conjugacy.

P2. *If $\{f^n\}_n$ is an equicontinuous family then $h(f) = 0$ and $R(f)$ is constant.*

Proof. Since $\{f^n\}_n$ is equicontinuous $\exists \delta > 0$ such that $\forall n \in \mathbf{N}$

$$|F_1^n(\bar{x}) - F_1^n(\bar{y})| < 1 \quad \text{if } |\bar{x} - \bar{y}| < \delta.$$

This implies that $\Gamma_x = \Gamma_y$ when $|x - y| < \delta$. Since A is compact it can be covered by finitely many open balls $(\beta_i)_{i=1, \dots, k}$ with radius $\delta/2$. The set of points without rotation number has zero measure and therefore the result follows. □

P3. $h(f^k) = |k|h(f), k \in \mathbf{Z}, \quad R(f^k) = kR(f), k \in \mathbf{Z}.$

(The proof follows directly from the definition, see Lemma 2.4.)

REMARK 3.1. (a) There exists a homeomorphism of A with infinite entropy. Set $A = \{(r, \theta) : 1 \leq r \leq 2 \text{ and } 0 \leq \theta \leq 2\pi\}$, Q_n a small square with edge $\leq 1/4n(n + 1)$. Let

$$A_n = \left\{ (r, \theta) : 1 + \frac{1}{n+1} \leq r \leq 1 + \frac{1}{n} \right\} \subset Q_n$$

and f a horseshoe map as seen below.

f is extended to a homeomorphism of A_n agreeing with the identity on the boundary, also denoted by f .

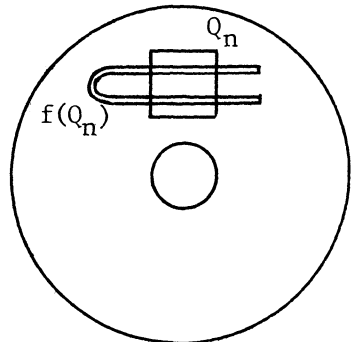

Defining $g : A \rightarrow A$ by $g|_{A_n} = f^n$, it follows that $h(g) \geq h(f^n) = n \log 2$ hence $h(g) = \infty$. Consequently for any p -manifold M , there exists a homeomorphism of M^p with infinite entropy that can be constructed by considering generalized horseshoe maps defined as above in p -cylinders conveniently embedded in M^p .

P4. *If the nonwandering set of f is finite then $h(f) = 0$ and $R(f)$ is finite.*

Proof. If f has finitely many periodic points then the result follows from Corollary 2.3. □

P5. *If $\{f^n\}_n$ is an equicontinuous family and g a homeomorphism of A that commutes with f then $h(f \circ g) = h(f) + h(g)$ and $R(f \circ g) = R(f) + R(g)$.*

Proof. For $\alpha \in R(f \circ g)$, $\exists x \in A$ and $(n_i)_i$ such that

$$\alpha = \lim_i \frac{(F \circ G)_1^{n_i}(\bar{x})}{n_i} = \lim_i \frac{F_1^{n_i}(G^{n_i}(\bar{x}))}{n_i}$$

and as setting several times before, $F = \iota + \Phi$, one gets

$$\begin{aligned} \alpha &= \lim_i \frac{F_1^{n_i}(G^{n_i}(\bar{x}))}{n_i} = \lim_i \left(\frac{G_1^{n_i}(\bar{x})}{n_i} + \frac{F_1^{n_i}(G^{n_i}(\bar{x})) - G_1^{n_i}(\bar{x})}{n_i} \right) \\ &= \lim_i \frac{G_1^{n_i}(\bar{x})}{n_i} + \lim_i \frac{\sum_{j=0}^{n_i-1} \Phi_1 \circ F^j \circ G^{n_i}(\bar{x})}{n_i}. \end{aligned}$$

Let x_0 be a limit point of $\{g^{n_i}(x)\}$ (assume $g^{n_i}(x) \rightarrow x_0$) and

$$L = \max\{|\Phi_1(y)|, y \in \mathbf{R} \times I\}.$$

The equicontinuity of $\{F^n\}_n$ and continuity of Φ assures the existence, for $\varepsilon > 0$, of n_0 such that

$$|\Phi_1 F^j G^{n_i}(\bar{x}) - \Phi_1 F^j(\bar{x}_0)| < \varepsilon, \quad \forall n_i \geq n_0.$$

Therefore

$$\begin{aligned} &\left| \frac{\sum_{j=0}^{n_i-1} [\Phi_1 \circ F^j \circ G^{n_i}(\bar{x}) - \Phi_1 \circ F^j(\bar{x}_0)]}{n_i} \right| \\ &\leq \left| \frac{\sum_{j=0}^{n_0-1} [\Phi_1 \circ F^j \circ G^{n_i}(\bar{x}) - \Phi_1 \circ F^j(\bar{x}_0)]}{n_i} \right| \\ &\quad + \left| \frac{\sum_{j=n_0}^{n_i-1} [\Phi_1 \circ F^j \circ G^{n_i}(\bar{x}) - \Phi_1 \circ F^j(\bar{x}_0)]}{n_i} \right| \\ &\leq \frac{2Ln_0}{n_i} + \frac{n_i - n_0}{n_i} \varepsilon \leq 2\varepsilon \quad \text{if } n_i \text{ is suitably large.} \end{aligned}$$

This leads to the equality

$$\lim_i \frac{\sum_{j=0}^{n_i-1} \Phi_1 \circ F^j \circ G^{n_i}(\bar{x})}{n_i} = \lim_i \frac{\sum_{j=0}^{n_i-1} \Phi_1 \circ F^j(\bar{x}_0)}{n_i} = \lim_i \frac{F_1^{n_i}(\bar{x}_0)}{n_i}.$$

Plugging this back into the expression for α , one gets

$$\alpha = \lim_i \frac{G_1^{n_i}(\bar{x})}{n_i} + \lim_i \frac{F_1^{n_i}(\bar{x}_0)}{n_i} \in R(g) + R(f).$$

This shows that $R(f \circ g) \subseteq R(f) + R(g)$.

Now we prove the other inclusion. Fix $\alpha \in R(g) + R(f)$. Then $\alpha = \beta + \delta$ with $\beta \in R(g)$ and $\delta \in R(f)$. Since $\beta \in R(g)$ there exists $x \in A$ and $(n_i)_i$ so that

$$\beta = \lim_i \frac{G_1^{n_i}(\bar{x})}{n_i}.$$

Let y be a limit point $\{g^{n_i}(\bar{x})\}$ (we assume that $g^{n_i}(x) \rightarrow y$). The equicontinuity of $\{F^n\}$ and P2 assures that $R(f)$ is constant. Then

$$\delta = \lim_i \frac{F_1^{n_i}(\bar{y}) - \bar{y}_1}{n_i} = \lim_i \frac{\sum_{j=0}^{n_i-1} \Phi_1 \circ F^j(\bar{y})}{n_i}.$$

Using, once more, the equicontinuity of $\{F^n\}_n$ we have that

$$\lim_i \frac{\sum_{j=0}^{n_i-1} \Phi_1 \circ F^j(\bar{y})}{n_i} = \lim_i \frac{\sum_{j=0}^{n_i-1} \Phi_1 \circ F^j \circ G^{n_i}(\bar{x})}{n_i}.$$

Plugging this back into the expression for α we get:

$$\begin{aligned} \alpha &= \lim_i \left(\frac{G_1^{n_i}(\bar{x})}{n_i} + \frac{\sum_{j=0}^{n_i-1} \Phi_1 \circ F^j \circ G^{n_i}(\bar{x})}{n_i} \right) \\ &= \lim_i \frac{F_1^{n_i}(G^{n_i}(\bar{x}))}{n_i} \in R(f \circ g). \end{aligned} \quad \square$$

Notice that P5 requires equicontinuity; just consider any homeomorphism f with non-trivial rotation set and $g = f^{-1}$.

Consider $C^0(A, A)$ the set of all continuous functions of A with the metric d_0 defined by $d_0(f, g) = \sup\{|F(\bar{x}) - G(\bar{x})|, \bar{x} \in I^2\}$ and $\mathfrak{P}(\mathbf{R})$ the set of all compact subsets of \mathbf{R} with the Hausdorff metric D :

$$D(X, Y) = \max\{\max\{(\min d(\alpha, \beta), \beta \in Y), \alpha \in X\}, \max\{(\min d(\alpha, \beta), \alpha \in X), \beta \in Y\}\}, \quad X, Y \in \mathfrak{P}(\mathbf{R}).$$

(d denotes the euclidean metric in \mathbf{R}).

Let $C^*(A, A)$ be the set of all continuous functions on A with the d_* metric. $\forall f, g \in C^*(A, A)$ $d_*(f, g) = \sup\{|\varphi(F^j(\bar{x})) - \psi(G^j(\bar{x}))| : \bar{x} \in I^2, j \in \mathbf{N}\}$, where F and G denote lifts of f and g , respectively, such that $F = \iota + \varphi$ and $G = \iota + \psi$ (cf. pg. 252).

Now let $h : C^0(A, A) \rightarrow \mathbf{R}$ be the entropy function and $\mathfrak{R} : C^*(A, A) \rightarrow \mathfrak{P}(\mathbf{R})$ be so that $\forall f \in C^*(A, A)$ $\mathfrak{R}(f) = \text{closure of } R(f)$.

P6. *The function h is discontinuous at f if f has finite entropy and some periodic point; the function \mathfrak{R} is uniformly continuous.*

Proof. We first prove that h is discontinuous at f if $h(f)$ is finite and f has some periodic point p . Without loss of generality assume p a fixed point, for ε small enough choose $\delta > 0$ with $f(\beta(p, \delta)) \subset \beta(p, \varepsilon) \subset A$ and select $\varepsilon_1 < \min\{\varepsilon, \delta\}$. We now define a homeomorphism g on A , which is an extension of a horseshoe map in $\beta(p, \varepsilon_1)$ that agrees with the identity elsewhere—see Remark 3.1 and the picture below.

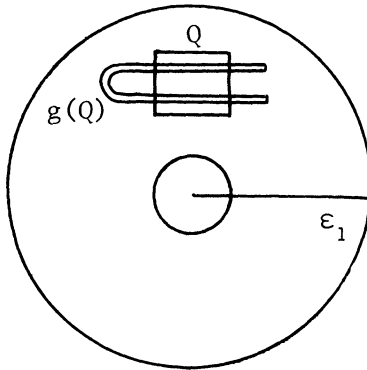

Let $\alpha : A \rightarrow [0, 1]$ be a bump function with value 1 in $\beta(p, \varepsilon_1)$ and 0 outside $\beta(p, \delta)$. We define $\bar{f}_n = \alpha g^n + (1 - \alpha)f$. It follows that $d_0(f, \bar{f}_n) < 2\varepsilon$, and $h(\bar{f}_n) \geq n \log 2$ since $h(g^n) \geq n \log 2$.

We now prove that \mathfrak{R} is uniformly continuous. Fix $\varepsilon > 0$ and $\alpha \in \mathfrak{R}(f)$, and choose $(n_i)_i$ and $x \in A$ so that:

$$\min_{\beta \in \mathfrak{R}(g)} d(\alpha, \beta) \leq \min_{\beta \in \mathfrak{R}(g)} \left| \frac{F_1^{n_i}(\bar{x})}{n_i} - \beta \right| + \varepsilon.$$

We have that $\{G_1^{n_i}(\bar{x})/n_i\}$ has some subsequence that converges to some number μ . Therefore we choose n_0 s.t.

$$\begin{aligned} \min_{\beta \in \mathfrak{R}(g)} d(\alpha, \beta) &\leq \left| \frac{F_1^{n_0}(\bar{x})}{n_0} - \mu \right| + \varepsilon \\ &\leq \left| \frac{F_1^{n_0}(\bar{x})}{n_0} - \frac{G_1^{n_0}(\bar{x})}{n_0} \right| + 2\varepsilon \\ &= \frac{\left| \sum_{j=0}^{n_0-1} [\Phi_1 \circ F^j(\bar{x}) - \Psi_1 \circ G^j(\bar{x}_0)] \right|}{n_0} + 2\varepsilon \\ &\leq d_*(f, g) + 2\varepsilon. \end{aligned}$$

Consequently we have $D(\mathfrak{R}(f), \mathfrak{R}(g)) \leq d_*(f, g)$. □

P7. Set $S = \{f \in \text{Diff}(A) : f \text{ has some point without rotation number}\}$ and $T = \{f \in \text{Diff}(A) : h(f) > 0\}$. Both sets have nonempty interior in the C^1 topology.

Proof. Denote $A = \{(r, \theta) : 1 \leq r \leq 2\}$ and $Q \subset A$ a small square with edge = $1/4$, consider a horseshoe map that contracts linearly in the vertical direction by a factor $\delta < 1/2$ and expands in the horizontal direction by a factor $1/\delta$ (see picture below). We can extend it to a diffeomorphism, f , of A (for details see [5]).

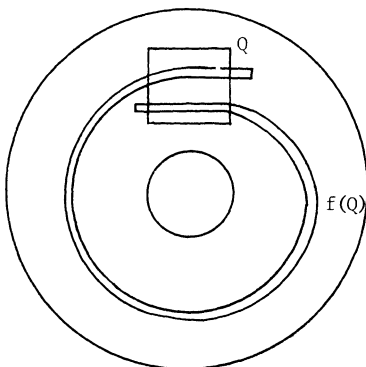

There exists an invariant hyperbolic set $\Lambda \subset Q$ where f is topologically conjugate to a shift σ in two symbols.

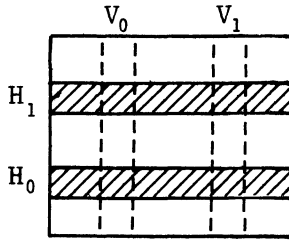

To each $x \in \Lambda$ we associate an infinite sequence $(\dots, a_{-1}, a_0, a_1, \dots)$ —the itinerary of x —so that:

$$\begin{aligned}
 a_j &= s && \text{iff } f^j(x) \in H_s \\
 a_{-j} &= s && \text{iff } f^{-j}(x) \in V_s \quad (\text{see [5] for details}).
 \end{aligned}$$

Now $\sigma(\dots, a_{-1}, a_0, a_1, \dots) = (\dots, b_{-1}, b_0, b_1, \dots)$ where $b_i = a_{i+1}$. We choose $x \in \Lambda$.

If $a_1 = 0$ then $|F_1(\bar{x}) - \bar{x}_1| \leq 1/4$.

If $a_1 = 1$ then $|F_1(\bar{x}) - \bar{x}_1 - 1| \leq 1/4$ (see picture below).

Therefore, in general we obtain $|F_1^n(\bar{x}) - \bar{x}_1 - k_n| \leq 1/4$, where k_n is the number of 1's that appear in $\{a_1, \dots, a_n\}$.

It follows that

$$\lim_n \frac{F_1^n(\bar{x}) - \bar{x}_1}{n} = \lim_n \frac{k_n}{n}.$$

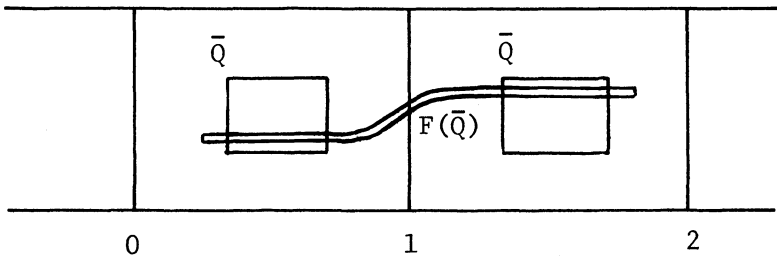

In order to find a point without rotation number simply choose a sequence $(\dots, a_{-1}, a_0, a_1, \dots)$ such that k_n/n does not converge.

More precisely we define a sequence of 0's and 1's with longer and longer blocks of only 0's or only 1's so that the sequence $(k_n/n)_n$ oscillates between getting very close to 0 and very close to 1. The point x associated with this itinerary does not have rotation number and the result follows from the stability of a hyperbolic set. The above proof also shows that T has nonempty interior. □

4. Some connections between entropy and rotation set. If f is a $C^{1+\varepsilon}$ diffeomorphism of A with positive entropy, Katok's theorem [11] implies that there exists a hyperbolic invariant Cantor set Λ such that $f|_{\Lambda}$ is topologically conjugate to a shift of n symbols. We note that either the rotation set of Λ reduces to one number or there exists some point without rotation number.

If $R(f|_{\Lambda})$ is not one number then we can choose x, y in Λ with different rotation numbers α, β .

To each point we associate a sequence of 0's and 1's

$$x \rightarrow (\dots, a_0, \dots) \quad \text{and} \quad y \rightarrow (\dots, b_0, \dots).$$

We now construct a new sequence by taking longer and longer blocks from the sequences associated to x and y in such a way that $(k_n/n)_n$ (see pg. 263 for the definition of k_n) gets progressively and alternately closer to α and β . The point corresponding to this sequence of 0's and 1's does not have rotation number.

DEFINITION. A diffeomorphism of A satisfies the Axiom A (see [4]) if it admits an Axiom A extension to S^2 .

EXAMPLE. In picture 1 below we give an example of a flow whose time one mapping defines an Axiom A diffeomorphism of the annulus.

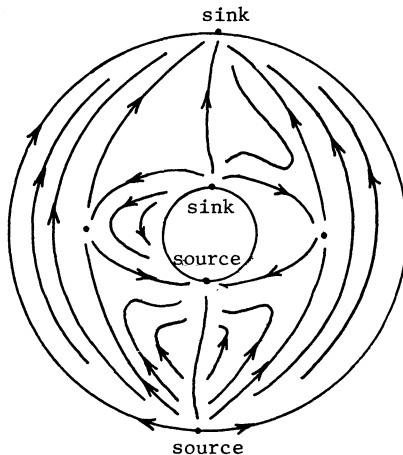

Each component of the boundary of A contains a source and a sink, and bounds a disk in S^2 .

Picture 2 shows how the flow can be extended to S^2 .

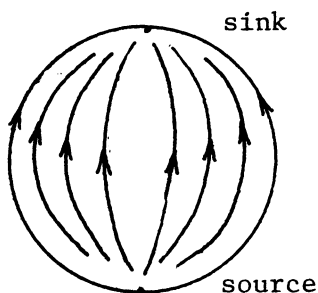

THEOREM 4.1 (Bowen [3]). *If f satisfies Axiom A and $h(f) = 0$ then the nonwandering set $\Omega(f)$ is finite.*

It follows easily that

COROLLARY 4.2. *If f is Axiom A and $h(f) = 0$ then every point has rotation number and $R(f)$ is constant.*

Proof. By 4.1 $\Omega(f)$ is finite. Corollary 2.3 implies that every point has rotation number and $R(f)$ is constant. \square

This leads to the following question: *Does zero entropy imply that every point has rotation number?*

Acknowledgments. I am grateful to J. Harrison for introducing me to this subject and for many useful and stimulating conversations; I also thank the referee specially for calling my attention to the work by Arason, Chorin, Hall and McGehee [2] and by Hockett and Holmes [9]. There it is shown how invariant Cantor sets embedded in the annulus contain uncountable many invariant sets, as well as periodic orbits and orbits without rotation number (see pg. 262–263); for this they use symbol sequences corresponding to certain orbits and after they translate results back into the corresponding ones in the annulus. Also LeCalvez in “Existence d’orbites quasi-périodiques dans les attracteurs de Birkhoff”, Orsay (1985) has obtained results like Proposition 2.1 on dissipative monotone twist maps.

REFERENCES

- [1] R. Adler, A. Konheim and M. McAndrew, *Topological entropy*, Trans. Amer. Math. Soc., **114** (1965), 309–319.
- [2] D. Aronson, M. Chory, G. Hall and R. McGehee, *Bifurcations from an invariant circle for two-parameter families of maps of the plane*, Commun. Math. Phys., **83** (1982), 303–354.

- [3] R. Bowen, *Topological entropy and Axiom A*, Proc. Sympos. Pure Math., Vol. **14** (Amer. Math. Soc., Providence, 1977).
- [4] ———, *On Axiom A diffeomorphisms*, Regional Conference Series in Math. **35** (Amer. Math. Soc., Providence, 1977).
- [5] R. Devaney, *An introduction to chaotic dynamical systems*, (Benjamin/Cummings Publishing, 1986).
- [6] J. Franks, *On recurrence of surface homeomorphisms*, preprint 1986.
- [7] W. Goodwyn, *Counterexamples in topological entropy*, Topology, **11** (1972).
- [8] M. Herman, *Sur la conjugaison différentiable des difféomorphismes du cercle a des rotations*, IHES, **49** (1979).
- [9] K. Hockett and P. Holmes, *Josephson's junction, annulus maps, Birkhoff attractors, horseshoes and rotation sets*, Ergodic Theory Dynamical Systems, **6** (1986), 205–239.
- [10] Y. Ito, *Rotation sets are closed*, Math. Proc. Cambridge Philos. Soc., **89** (1983).
- [11] A. Katok, *Lyapunov exponents, entropy and periodic orbits for diffeos*, IHES, **51** (1981).
- [12] M. Misiurewicz, *On non-continuity of topological entropy*, Bull. Acad. Polon. Sci., **19** (1970), 319–320.
- [13] M. Rees, *A minimal positive entropy homeomorphism*, LMS Journal **23** (1985).
- [14] H. Royden, *Real Analysis*, (Macmillan company, 1970).

Received September 29, 1986 and in revised form October 23, 1987. This work was partially supported by a NATO Fellowship.

UNIVERSITY OF CALIFORNIA
BERKELEY, CA 94720

AND

UNIVERSIDADE DO PORTO
PORTO, PORTUGAL

PACIFIC JOURNAL OF MATHEMATICS

EDITORS

V. S. VARADARAJAN
(Managing Editor)
University of California
Los Angeles, CA 90024

HERBERT CLEMENS
University of Utah
Salt Lake City, UT 84112

R. FINN
Stanford University
Stanford, CA 94305

HERMANN FLASCHKA
University of Arizona
Tucson, AZ 85721

RAMESH A. GANGOLLI
University of Washington
Seattle, WA 98195

VAUGHAN F. R. JONES
University of California
Berkeley, CA 94720

ROBION KIRBY
University of California
Berkeley, CA 94720

C. C. MOORE
University of California
Berkeley, CA 94720

HAROLD STARK
University of California, San Diego
La Jolla, CA 92093

ASSOCIATE EDITORS

R. ARENS

E. F. BECKENBACH
(1906-1982)

B. H. NEUMANN

F. WOLF

K. YOSHIDA

SUPPORTING INSTITUTIONS

UNIVERSITY OF ARIZONA
UNIVERSITY OF BRITISH COLUMBIA
CALIFORNIA INSTITUTE OF TECHNOLOGY
UNIVERSITY OF CALIFORNIA
MONTANA STATE UNIVERSITY
UNIVERSITY OF NEVADA, RENO
NEW MEXICO STATE UNIVERSITY
OREGON STATE UNIVERSITY

UNIVERSITY OF OREGON
UNIVERSITY OF SOUTHERN CALIFORNIA
STANFORD UNIVERSITY
UNIVERSITY OF HAWAII
UNIVERSITY OF TOKYO
UNIVERSITY OF UTAH
WASHINGTON STATE UNIVERSITY
UNIVERSITY OF WASHINGTON

The Supporting Institutions listed above contribute to the cost of publication of this Journal, but they are not owners or publishers and have no responsibility for its content or policies.

Mathematical papers intended for publication in the *Pacific Journal of Mathematics* should be in typed form or offset-reproduced (not dittoed), double spaced with large margins. Please do not use built up fractions in the text of the manuscript. However, you may use them in the displayed equations. Underline Greek letters in red, German in green, and script in blue. The first paragraph must be capable of being used separately as a synopsis of the entire paper. In particular it should contain no bibliographic references. Please propose a heading for the odd numbered pages of less than 35 characters. Manuscripts, in triplicate, may be sent to any one of the editors. Please classify according to the scheme of Math. Reviews, Index to Vol. 39. Supply name and address of author to whom proofs should be sent. All other communications should be addressed to the managing editor, or Elaine Barth, University of California, Los Angeles, California 90024.

There are page-charges associated with articles appearing in the Pacific Journal of Mathematics. These charges are expected to be paid by the author's University, Government Agency or Company. If the author or authors do not have access to such Institutional support these charges are waived. Single authors will receive 50 free reprints; joint authors will receive a total of 100 free reprints. Additional copies may be obtained at cost in multiples of 50.

The *Pacific Journal of Mathematics* is issued monthly as of January 1966. Regular subscription rate: \$190.00 a year (5 Vols., 10 issues). Special rate: \$95.00 a year to individual members of supporting institutions.

Subscriptions, orders for numbers issued in the last three calendar years, and changes of address should be sent to Pacific Journal of Mathematics, P.O. Box 969, Carmel Valley, CA 93924, U.S.A. Old back numbers obtainable from Kraus Periodicals Co., Route 100, Millwood, NY 10546.

The Pacific Journal of Mathematics at P.O. Box 969, Carmel Valley, CA 93924 (ISSN 0030-8730) publishes 5 volumes per year. Application to mail at Second-class postage rates is pending at Carmel Valley, California, and additional mailing offices. Postmaster: send address changes to Pacific Journal of Mathematics, P.O. Box 969, Carmel Valley, CA 93924.

PUBLISHED BY PACIFIC JOURNAL OF MATHEMATICS, A NON-PROFIT CORPORATION

Copyright © 1988 by Pacific Journal of Mathematics

William Charles Bauldry, Attila Mate and Paul Nevai, Asymptotics for solutions of systems of smooth recurrence equations	209
Ehrhard Behrends, Isomorphic Banach-Stone theorems and isomorphisms which are close to isometries	229
Fernanda Maria Botelho, Rotation sets of maps of the annulus	251
Edward Graham Evans, Jr. and Phillip Alan Griffith, Binomial behavior of Betti numbers for modules of finite length	267
Andrei Iordan, Pseudoconvex domains with peak functions at each point of the boundary	277
Zyun'iti Iwase, Dehn-surgery along a torus T^2-knot	289
Marko Kranjc, Embedding 2-complexes in \mathbf{R}^4	301
Aloys Krieg, Eisenstein-series on real, complex, and quaternionic half-spaces	315
Masato Kuwata, Intersection homology of weighted projective spaces and pseudo-lens spaces	355
Carl Pomerance, András Sárközy and Cameron Leigh Stewart, On divisors of sums of integers. III	363
Martin Schechter, Potential estimates in Orlicz spaces	381