

*Pacific
Journal of
Mathematics*

**SIMPLE WHITNEY TOWERS, HALF-GROPES
AND THE ARF INVARIANT OF A KNOT**

ROB SCHNEIDERMAN

SIMPLE WHITNEY TOWERS, HALF-GROPE AND THE ARF INVARIANT OF A KNOT

ROB SCHNEIDERMAN

A geometric characterization of the Arf invariant of a knot in the 3-sphere is given in terms of two kinds of 4-dimensional bordisms, *half-gropes* and *Whitney towers*. These types of bordisms have associated complexities *class* and *order* which filter the condition of bordism by an embedded annulus, i.e. knot concordance, and it is shown constructively that the Arf invariant is exactly the obstruction to cobordism pairs of knots by half-gropes and Whitney towers of arbitrarily high class and order, respectively. This illustrates geometrically how, in the setting of knot concordance, the Vassiliev (isotopy) invariants “collapse” to the Arf invariant.

1. Introduction

This paper gives a geometric characterization of the Arf invariant of a knotted circle in the 3-sphere that is related to recent developments in knot theory [Teichner 2002]. Conant and Teichner [2004b] have shown that the Vassiliev finite type filtration [Bar-Natan 1995] on isotopy classes of knots corresponds to a geometric equivalence relation called *3-dimensional capped grope-cobordism* and that this equivalence relation is generated by certain simplified *half-gropes* in S^3 . Gropes (see [Teichner 2004]) are 2-complexes built by gluing together embedded surfaces and in this setting the Vassiliev degree corresponds to a measure of grope complexity called *class*, which counts the layers of attached surfaces. The Arf invariant $\text{Arf } k \in \mathbb{Z}_2$ of a knot $k \subset S^3$ is the mod 2 reduction of the lowest degree nontrivial finite type knot invariant (the degree two coefficient of the Conway polynomial of k) and a result of Ng [1998] says that $\text{Arf } k$ is the only finite type invariant of k up to *concordance*, that is, up to bordism of k by an embedded annulus in the product $S^3 \times I$ of the 3-sphere with an interval. Gropes have been extensively studied in 4-dimensional topology; see for example [Freedman and Quinn 1990; Freedman and Teichner 1995; Krushkal 2000; Krushkal and Quinn 2000; Krushkal and Teichner 1997]; they are closely related to *Whitney towers* which measure the

This work was supported in part by an NSF VIGRE grant.
MSC2000: 57M25.

Keywords: Arf invariant, knot, grope, Whitney tower, Whitney disk.

failure of the Whitney move in terms of intersections among higher order Whitney disks [Cochran et al. 2003; Schneiderman \geq 2005; Schneiderman and Teichner 2001; 2004].

The following theorem illustrates geometrically how, in the setting of knot concordance, the Vassiliev isotopy invariants “collapse” to the Arf invariant and the failure of the Whitney move can be “pushed out” to arbitrarily high order Whitney disks:

Theorem 1. *For knots k_0 and k_1 in S^3 the following statements are equivalent:*

- (i) $\text{Arf}(k_0) = \text{Arf}(k_1)$,
- (ii) k_0 and k_1 cobound a properly embedded class n half-grope in $S^3 \times I$ for all $n \in \mathbb{N}$,
- (iii) k_0 and k_1 cobound a properly immersed annulus in $S^3 \times I$ admitting an order n Whitney tower for all $n \in \mathbb{N}$.

It follows from Theorem 1 and a result in [Schneiderman \geq 2005] (which describes how to convert gropes into half-gropes) that a knot in the 3-sphere has trivial Arf invariant if and only if it bounds embedded gropes (not necessarily half-gropes) of arbitrarily high class in the 4-ball.

Definitions of Whitney towers, Arf k and half-gropes will be given in Sections 2, 3 and 4, respectively. Theorem 1 will be proved constructively by exploiting the flexibility of the Whitney towers in (iii). The infinite cyclic Vassiliev (isotopy) invariant which lifts the Arf invariant can be interpreted as the obstruction to “pushing down” this construction into the 3-sphere.

Remark. The equivalence of (i) and (ii) also follows indirectly from results in [Conant and Teichner 2004b; 2004a; Cochran et al. 2003]; see particularly [Conant and Teichner 2004a, Proposition 3.8].

It should be mentioned that slight variations of the bordism equivalence relations of class n grope concordance and order n Whitney concordance suggested by (ii) and (iii) are highly nontrivial. For instance, when using “height” instead of class and order to measure complexity, Cochran and Teichner [2003] have used von Neumann ρ -invariants to show that the associated filtration on grope (and Whitney) concordance classes of knots is nontrivial for all n [Cochran and Teichner 2004]. (And see comment regarding links following Lemma 3 below.)

Simple Whitney towers. The essential arguments in the proof of Theorem 1 are contained in two lemmas. The first describes a close relationship between half-gropes and certain simple Whitney towers (Section 4.2) both of which are geometric analogues of simple (right- or left-normed) commutators in a group [Magnus et al. 1976].

Lemma 2. *Let L be a link in the boundary of a simply connected 4-manifold. Then L is the boundary of the bottom stage of a properly embedded half-grope of class n if and only if L is the boundary of a properly immersed planar surface which admits a simple Whitney tower of order $n - 1$.*

Remark. A much more general relation between class n grope and order $n - 1$ Whitney towers in (not necessarily simply connected) 4-manifolds is described in [Schneiderman \geq 2005].

Whitney towers are of interest in their own right, in part because an order n Whitney tower comes equipped with an n -th order geometric intersection obstruction to the existence of an $(n+1)$ -th order tower which is related to Milnor's $\bar{\mu}$ link invariants [Schneiderman and Teichner \geq 2005] and the Kontsevich integral, and is conjectured to generalize to give homotopy invariants of immersed surfaces in arbitrary 4-manifolds; see [Schneiderman and Teichner 2001; 2004]. The next lemma illustrates how in the present setting (of knots in a simply connected manifold) the obstruction theory collapses after order 2.

Lemma 3. *A properly immersed connected surface in a simply connected 4-manifold admitting an order 2 Whitney tower admits an order n simple Whitney tower for all n .*

The connectivity conditions in Lemma 3 are crucial. For instance, as explained in [Schneiderman and Teichner 2004], in the setting of *link* concordance, a first nonvanishing term of Vassiliev degree n in the tree part of the Kontsevich integral is an obstruction to building a Whitney tower of order n on a collection of immersed disks in the 4-ball bounded by the link components in S^3 , and the already mentioned higher order Whitney tower intersection obstruction is conjectured to be (highly) nontrivial for connected surfaces in *non*-simply connected 4-manifolds.

Outline. Whitney towers are defined in Section 2, which also describes the basic geometric manipulations of immersed surfaces in 4-manifolds that we will use. The Arf invariant is defined in Section 3. Lemma 2 is proved in Section 4, which also contains definitions of half-grope and simple Whitney towers. Lemma 3 is proved in Section 5 and the proof of Theorem 1 is assembled in Section 6. All manifolds are assumed smooth and oriented.

2. Whitney towers

Whitney towers are introduced in this section, along with some fundamental techniques from the theory of immersed surfaces in 4-manifolds. More information about Whitney towers can be found in [Cochran et al. 2003; Conant et al. 2004; Schneiderman \geq 2005; Schneiderman and Teichner 2001; 2004]. For more details on surfaces in 4-manifolds the reader is referred to [Freedman and Quinn 1990].

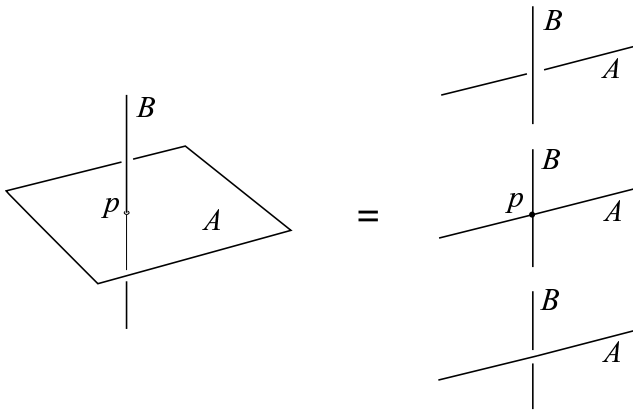

Figure 1. A generic transverse intersection point p between surfaces A and B in a 4-manifold.

It will be convenient to illustrate surfaces locally in 4-space by picturing 3-dimensional slices in which a surface may appear either in the “present slice” or as an arc which extends into neighboring slices; surfaces may also appear as a “movie of arcs” in a sequence of 3-dimensional slices (Figure 1).

2.1. Whitney disks. In a simply connected 4-manifold X , two intersection points between oriented connected surfaces A and B are called a *cancelling pair* if they have opposite signs (via the usual sign convention that compares the orientations of the surfaces at an intersection point with the orientation of the ambient manifold). Such a cancelling pair p and q in $A \cap B$ can be paired by a *Whitney disk* as follows: The union of an arc α from p to q in A and an arc β from q to p in B forms a loop in X which bounds an immersed 2-disk W meeting A and B along ∂W in the standard way. Such a W is a *Whitney disk* pairing p and q . (An embedded Whitney disk is shown in Figure 2.) The normal disk bundle νW of W in X pulls back to a trivial D^2 -bundle over the pre-image of W (which is contractible). The restriction of νW to ∂W has a canonical 1-dimensional sub-bundle ν_∂ which restricts along α

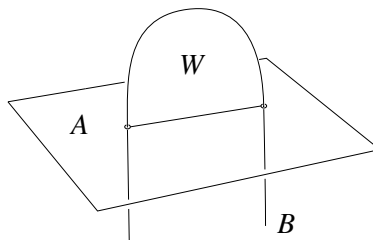

Figure 2. An embedded Whitney disk W pairing intersections between surfaces A and B .

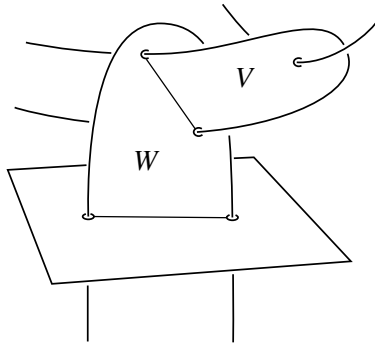

Figure 3. Part of an order n Whitney tower. The Whitney disk V contains an unpaired intersection point which must be of order greater than or equal to n .

to the normal bundle of α in A and restricts along β to the orthogonal complement (in νW) of the normal bundle of β in B . Since p and q have opposite signs, ν_{∂} is a trivial I -bundle over ∂W . The obstruction to extending a nonvanishing section of ν_{∂} to a nonvanishing section of νW is an element of $\pi_1 SO(2) \cong \mathbb{Z}$. If this obstruction vanishes then W is said to be (correctly) *framed*.

2.2. Definition of a Whitney tower. A Whitney disk can be used to eliminate its cancelling pair of intersection points via a *Whitney move* (a motion of one of the sheets guided by the Whitney disk), as introduced in [Whitney 1944] for higher-dimensional manifolds immersed in Euclidean space. In the present 4-dimensional setting, a Whitney move will create new intersections if the interior of the Whitney disk has any “higher order” intersections with sheets of surfaces or Whitney disks (or if the Whitney disk is not framed), whereas in dimensions greater than 4, such higher order intersection points can be eliminated by general position. The following notion of a *Whitney tower* filters the condition that a properly immersed surface in a 4-manifold is homotopic (rel boundary) to an embedding.

Definition. A *surface of order 0* in a 4-manifold X is a properly immersed surface (that is, its boundary is embedded in the boundary of X and its interior is immersed in the interior of X). A *Whitney tower of order 0* in X is a collection of order 0 surfaces.

The *order of a (transverse) intersection point* between a surface of order n and a surface of order m is $n + m$.

The *order of a Whitney disk* is $(n+1)$ if it pairs intersection points of order n .

For $n \geq 0$, a *Whitney tower of order $(n+1)$* is a Whitney tower \mathcal{W} of order n together with (framed) Whitney disks pairing all order n intersection points of \mathcal{W} .

(These top order disks are allowed to intersect each other as well as lower order surfaces.)

All Whitney disks in a Whitney tower are oriented (arbitrarily) and are required to have disjointly embedded boundaries.

If A is a properly immersed surface in a 4-manifold and there exists an order n Whitney tower containing A as its order 0 surface, then A is said to *admit* an order n Whitney tower.

If a Whitney tower of order n has no intersection points of order greater than or equal to n , then the Whitney disks can be used to guide a regular homotopy (rel boundary) of the order 0 surfaces to an embedding.

2.3. Modifying Whitney disks. There are several moves that allow for controlled modification of Whitney towers. Since the moves are supported in a neighborhood of an arc or a point they commute with each other and can be iterated disjointly arbitrarily many times.

The first two *twisting moves* change the framing of a Whitney disk.

2.3.1. Interior twisting. Introducing a self-intersection in the interior $\overset{\circ}{W}$ of W by a *cuspl homotopy* (see Figure 4) changes the framing by ± 2 as can be seen by counting the intersections between a local kink and its parallel push off.

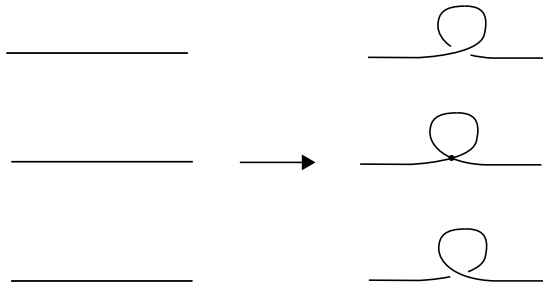

Figure 4. A local cuspl homotopy.

2.3.2. Boundary twisting. Introducing a *boundary twist* by changing a collar of W near a point in ∂W (as in Figure 5) changes the framing by ± 1 and creates an intersection between $\overset{\circ}{W}$ and the sheet containing ∂W .

The next two moves do not affect framing but can be used to make Whitney disks disjointly embedded.

2.3.3. Boundary push-off. Intersections or self-intersections between boundaries of Whitney disks can always be eliminated by a regular homotopy in a collar at the cost of creating an intersection between the interior of a Whitney disk and a surface sheet (Figure 6).

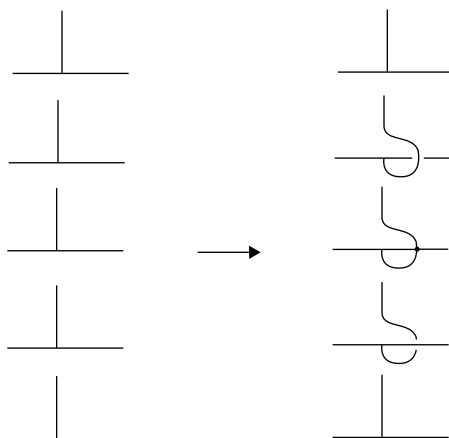

Figure 5. Boundary twisting a Whitney disk.

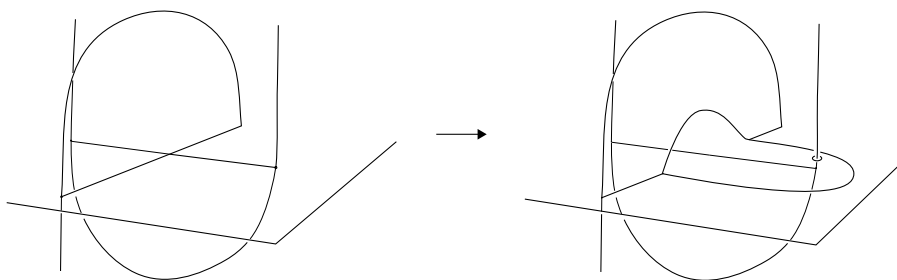

Figure 6. Boundary push-off.

2.3.4. Pushing down an intersection point. An intersection point between \hat{W} and any surface S can be removed by a *finger move* on S , a homotopy of S supported in a neighborhood of an arc, in this case an arc in W from the intersection to a point in ∂W (Figure 7, left). Such a finger move is called “pushing S down” into either sheet and creates two new cancelling pairs of intersection points between S and the sheet. This move can also be used to remove interior self-intersections of W . Note that the newly created cancelling pair can be paired by an embedded Whitney disk V whose boundary is disjoint from W by applying the boundary push-off move to the obvious small embedded Whitney disk near the cancelling pair. The interior of V has a single intersection point with the sheet that was not “pushed into” as illustrated in Figure 7, right.

2.4. Order 1 towers for knots. Applying the moves of Section 2.3 yields the next lemma, which will be used in the definition of the Arf invariant.

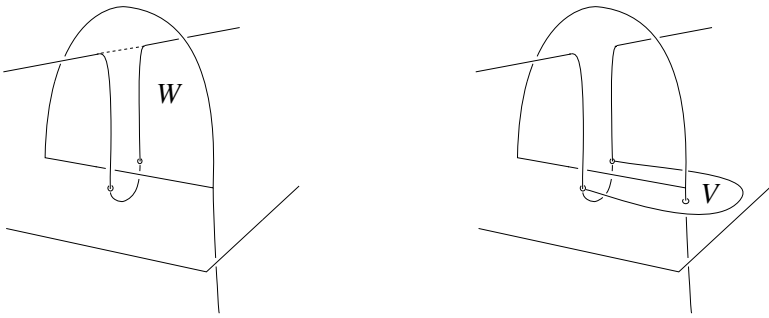

Figure 7. Left: Pushing down an intersection between the interior of a Whitney disk W and a sheet of a surface. Right: A Whitney disk V for the cancelling pair created by pushing down (with ∂V and ∂W disjoint).

Lemma 4. Any knot k in S^3 bounds a properly immersed 2-disk in $S^3 \times I$ admitting a Whitney tower of order 1.

Proof. A finite number of crossing changes, leading from k to the unknot, describes a properly immersed 2-disk D in $S^3 \times I$ (with the unknot capped off by an embedded disk). Fixing orientations, the signs of the self-intersections of D correspond to the signs of the crossing changes and, after introducing trivial crossing changes (if necessary), the self-intersections of D can be made to occur in cancelling pairs of order 0 intersections which are paired by Whitney disks of order 1 as in Section 2.1. By applying boundary twists (2.3.2) and boundary push-off (2.3.3) as needed, it can be arranged that the Whitney disks are framed with disjointly embedded boundaries. \square

3. The Arf invariant

Robertello [1965] used Kervaire and Milnor's [1961] generalization of Rochlin's Theorem to define a \mathbb{Z}_2 -valued concordance invariant of a knot in S^3 , and showed that it was equal to the Arf invariant of a quadratic enhancement of (the mod 2 reduction of) the Seifert form. (The Arf invariant of a nondegenerate quadratic form is defined as 0 or 1 depending on whether a majority of elements are taken to 0 or 1.) This invariant has numerous characterizations, all of which are commonly referred to as the Arf invariant (of a knot). The following geometric definition, which we have translated into the language of Whitney towers, is due to Matsumoto [1978], using Freedman and Kirby's [1978] geometric proof of Rochlin's Theorem.

Definition. For a knot k in S^3 , let D be any properly immersed 2-disk immersed in $S^3 \times I$ admitting a Whitney tower \mathcal{W} of order 1, with $k = \partial D \subset S^3 \times \{0\}$. Define the *Arf invariant* of k , $\text{Arf } k \in \mathbb{Z}_2$, to be the number (modulo 2) of order 1 intersection points in \mathcal{W} .

By Lemma 4, such a W always exists. A direct combinatorial proof that this definition of $\text{Arf } k$ is well-defined can be found in [Freedman and Quinn 1990, 10.8].

3.1. The trefoil. That the trefoil knot has nontrivial Arf invariant can be seen in Figure 8, where changing the crossings labelled p^+ and p^- creates a cancelling pair of order 0 intersections in a null-homotopy D . This cancelling pair has a framed embedded Whitney disk W which intersects D in a single intersection point of order 1.

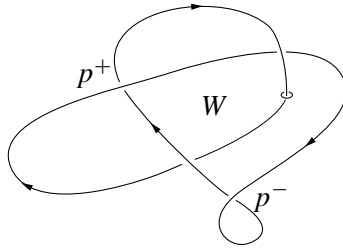

Figure 8. The trefoil has nontrivial Arf invariant.

4. Half-gropes and simple Whitney towers

We next prove Lemma 2, after first defining half-gropes and simple Whitney towers, two geometric analogues of a simple (right- or left-normed) commutator of elements in a group [Magnus et al. 1976]. It should be noted that the fact that we are working with *half*-gropes and *simple* Whitney towers is crucial in the proof of Lemma 2. In the setting of general gropes and Whitney towers, showing the correspondence between class and order involves more subtle geometric constructions; see [Schneiderman \geq 2005]. Basic operations on gropes used in this section, such as surgery, are described in detail in [Freedman and Quinn 1990].

4.1. Half-gropes. In general, gropes are 2-complexes consisting of surfaces joined along certain essential curves; see [Conant and Teichner 2004b; Freedman and Quinn 1990; Teichner 2004]. Requiring that the curves form a “half-basis” yields the “half-gropes”:

Definition. A *half-grope of class 2* is a compact connected orientable surface A with a single boundary circle. To form a *half-grope of class $n > 2$* , start with an orientable surface A with a single boundary circle and choose a symplectic basis $\{a_i, b_i\}$, that is, the a_i and b_i are embedded curves which represent a basis for $H_1(A)$ and the only intersections among them occur when a_i meets b_i in a single point. Now attach half-gropes of class $n - 1$ along their boundary circles to a $\frac{1}{2}$ -symplectic basis for A , i.e., a maximal pairwise disjoint subset of $\{a_i, b_i\}$, for instance $\{a_i\}$.

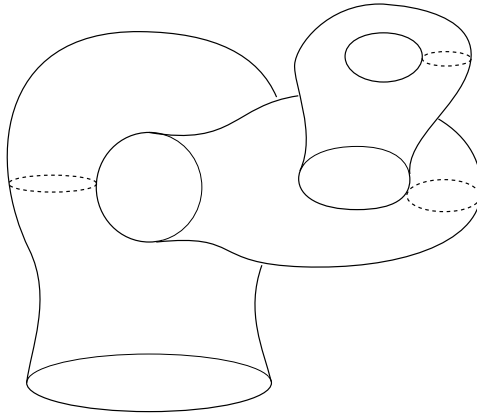

Figure 9. A half-grope of class 4.

The surface A is called the *bottom stage* of the half-grope and the boundary circle of A is the *boundary* of the half-grope. Half-gropes with more than one boundary component are formed by removing disks from the bottom stage of a half-grope. The attached punctured surfaces are also called *higher stages*, or simply *stages*. Basis curves having no attached higher stages are the *tips* of the half-grope.

A half-grope H is *properly embedded* in a 4-manifold X if the boundary of H is embedded in ∂X and the rest of H is embedded in \mathring{X} . It is also required that H satisfy the following *normal framing condition*: A regular neighborhood of H in X must factor as a standard embedding of H into 3-space followed by taking the product with an interval.

4.2. Simple Whitney towers. A Whitney tower is *simple* if all of its Whitney disks have disjointly embedded interiors. Thus, every intersection point of order m in a simple Whitney tower is an intersection between a surface of order 0 and a surface of order m .

4.3. Proof of Lemma 2. Let H be a half-grope of class n properly embedded in X and bounded by L . Since X is simply connected, the tips of H bound immersed 2-disks called *caps* and the plan is to create the desired Whitney tower by surgering the caps. Each cap has a normal framing determined by pushing its boundary along H and after boundary twisting the cap (just as in 2.3.2) this framing can be made to vanish. We may also arrange, by repeatedly pushing down intersections as for Whitney disks (2.3.4), that the caps of H are disjointly embedded (except for the single boundary point intersections between dual caps in the top stages) with interiors disjoint from all stages of H except for perhaps the bottom stage. Assume first that the bottom stage intersects the interior of each cap in at most a single point. Let A be the result of surgering those caps attached to the bottom stage surface of

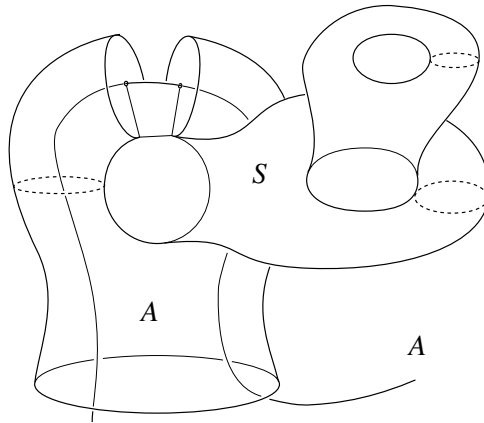

Figure 10. Intersections created by surgering caps can be paired by Whitney disks constructed from surgered higher stages of the half-grope. Surgering a cap bounded by the dotted circle (tip) on S creates a Whitney disk.

H . Then A is a properly immersed planar surface with self-intersection points coming in cancelling pairs which were created by surgering a cap whose interior intersected the bottom stage surface. Such a cancelling pair has an embedded (first order) Whitney disk W which is the union of a small band and the result of surgering the caps on the next stage surface S , which was attached along the dual curve to the boundary of the cap (Figure 10). The framing condition (see definition on page 177) on the normal bundle of H in X ensures that W is correctly framed. The only possible intersections between the interior of W and anything else are intersections with A coming from intersections between A and the surgered caps on S , hence occur in cancelling pairs with an embedded second order Whitney disk gotten by similarly surgering the next surface stage. This construction terminates at the top $(n-1)$ -th stage surfaces, where only a half-basis of caps are surgered to make the order $(n-2)$ Whitney disks and the dual caps (together with bands) form the order $(n-1)$ Whitney disks yielding the desired simple Whitney tower.

The above assumption that each cap has at most a single interior intersection with the bottom surface can always be arranged by Krushkal's grope splitting technique [2000]; alternatively, the above construction can still be carried out for "nearby" cancelling pairs created by surgering caps containing multiple interior intersections by using parallel disjoint copies (guaranteed by the normal framing condition) of the higher surfaces stages of H to build the higher order Whitney disks. This completes one direction of the proof of Lemma 2.

For the other direction, let \mathcal{W} be a simple order $n-1$ Whitney tower on a properly immersed planar surface A in X bounded by L . Since \mathcal{W} is simple, each

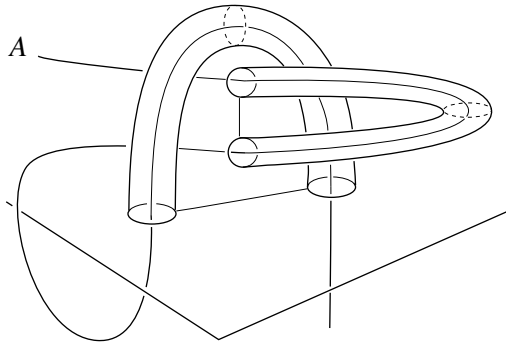

Figure 11. A simple Whitney tower of order $n - 1$ yields a half-grope of class n by “tubing along A ”.

of its Whitney disks has (at least one) boundary arc lying in A (the order 1 Whitney disks have both boundary arcs on A). The desired half-grope H of class n is constructed by “tubing the Whitney disks of \mathcal{W} along A ” as illustrated in [Figure 11](#): More specifically, let W be any order m Whitney disk ($1 \leq m \leq n - 1$) for a pair of cancelling order $m - 1$ intersections between A and an order $m - 1$ Whitney disk V (if $m = 1$, then V is just the order zero surface A). Denote by $\partial_A W$ the part of the boundary of W that lies in A (if $m = 1$, choose a boundary arc of ∂W). Using the boundary annulus of the normal disk bundle to A in X restricted to $\partial_A W$ to perform 0-surgery on V eliminates the cancelling pair of intersections between A and V . If $m = n - 1$, then W is discarded; if $1 \leq m < n - 1$, then W (minus a small collar near $\partial_A W$) becomes an $(m + 1)$ -th stage surface of H by 0-surgering the interior of W to eliminate any intersections with A . Applying this construction to all the Whitney disks of \mathcal{W} yields H , with the bottom stage surface of H consisting of 0-surgery (one for each first order Whitney disk) on A and each m -th stage surface 0-surgery on an $(m - 1)$ -th order Whitney disk. The normal framing condition on H is satisfied since all the Whitney disks of \mathcal{W} were framed. \square

5. Proof of [Lemma 3](#)

The idea of the proof of [Lemma 3](#) is that, for an order n simple Whitney tower whose order 0 surface is *connected*, any order n intersection point can be cancelled by boundary twisting its order n Whitney disk into the order 0 surface (in a simply connected 4-manifold). The framing on the Whitney disk can then be recovered by boundary twisting along the other boundary arc of the Whitney disk, which only creates an intersection point of order $n + (n - 1)$, which is greater than n for $n \geq 2$.

Proof. Let A be a properly immersed connected surface in a simply connected 4-manifold X admitting an order 2 Whitney tower \mathcal{W} . A simple order 2 Whitney tower can be constructed from \mathcal{W} by pushing down any intersections among its Whitney disks into A : Pushing down (order 2) intersections among the first order Whitney disks creates cancelling pairs of (order 1) intersections which can be equipped with disjointly embedded second order Whitney disks having a single interior (order 2) intersection with A (Figure 7). Pushing down intersections among second order disks and between second and first order disks creates cancelling pairs of second order intersections between the second order disks and A .

Now assume inductively that A admits a simple Whitney tower \mathcal{W}_n of order $n \geq 2$. Since the interiors of all Whitney disks in \mathcal{W}_n are disjointly embedded, the only possible unpaired intersection points are n -th order intersections between n -th order Whitney disks and A .

Let p be such an intersection point between an n -th order Whitney disk W and A . Since \mathcal{W}_n is simple, W pairs intersections between A and an $(n-1)$ -th order Whitney disk (recall $n \geq 2$). By performing a boundary twist around the arc of ∂W that lies on A , we can create an intersection point $q \in \mathring{W} \cap A$ of opposite sign as p . Since A is connected (and the 4-manifold is simply connected), p and q can be paired by an $(n+1)$ -th order Whitney disk.

To restore the framing of W , perform a boundary twist along the (other) arc of ∂W that lies on the $(n-1)$ -th order Whitney disk, creating a $(2n-1)$ -th order intersection point between W and the $(n-1)$ -th order Whitney disk. This $(2n-1)$ -th order intersection point can be eliminated by repeatedly pushing \mathring{W} down into Whitney disks of lower order as in Figure 12 until eventually reaching A , where

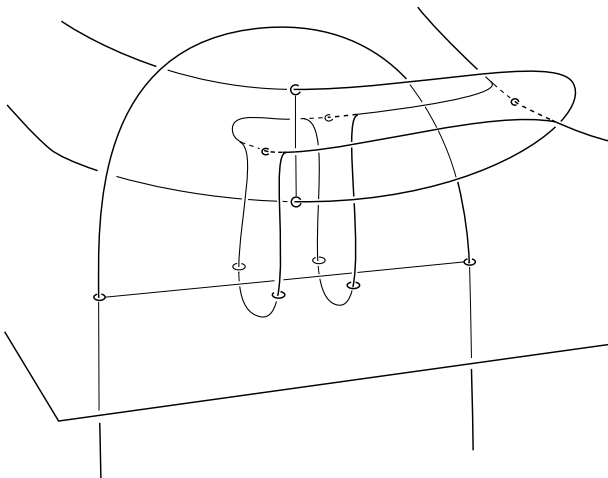

Figure 12

$2^{(n-2)}$ cancelling pairs of order n intersections between \mathring{W} and A will be created. These cancelling pairs admit disjointly embedded order n Whitney disks (parallel copies of the Whitney disk V pictured in Figure 7, right), each having a single intersection of order $n + 1$ with A .

Since this modification of \mathring{W}_n takes place in a neighborhood of a 1-complex, it may be repeated (in disjoint neighborhoods) until all order n intersections are paired by order $(n+1)$ Whitney disks. The boundaries of these $(n+1)$ -th order Whitney disks can be made disjointly embedded (and disjoint from all other Whitney disk boundaries) by applying boundary push-off moves (2.3.3). Finally, intersections between any Whitney disk and the $(n+1)$ -th order Whitney disks can be eliminated by repeatedly pushing the $(n+1)$ -th order Whitney disks down (as in Figure 12) until they only intersect A , yielding a simple Whitney tower of order $n+1$. \square

6. Proof of Theorem 1

(iii) \Rightarrow (i) Let A be an annulus admitting an order $n \geq 2$ Whitney tower \mathring{W} as in (iii). Then any 2-disk D_0 admitting an order 1 Whitney tower \mathring{W}_0 in $S^3 \times I$ and bounded by k_0 can be extended by A to a 2-disk $D_1 = A \cup D_0$ in $S^3 \times I$ admitting an order 1 Whitney tower $\mathring{W}_1 = \mathring{W} \cup \mathring{W}_0$ and bounded by k_1 . Since $n \geq 2$, all order 1 intersection points in \mathring{W} occur in cancelling pairs, so \mathring{W}_1 has the same number (modulo 2) of order 1 intersection points as \mathring{W}_0 and $\text{Arf } k_1 = \text{Arf } k_0$.

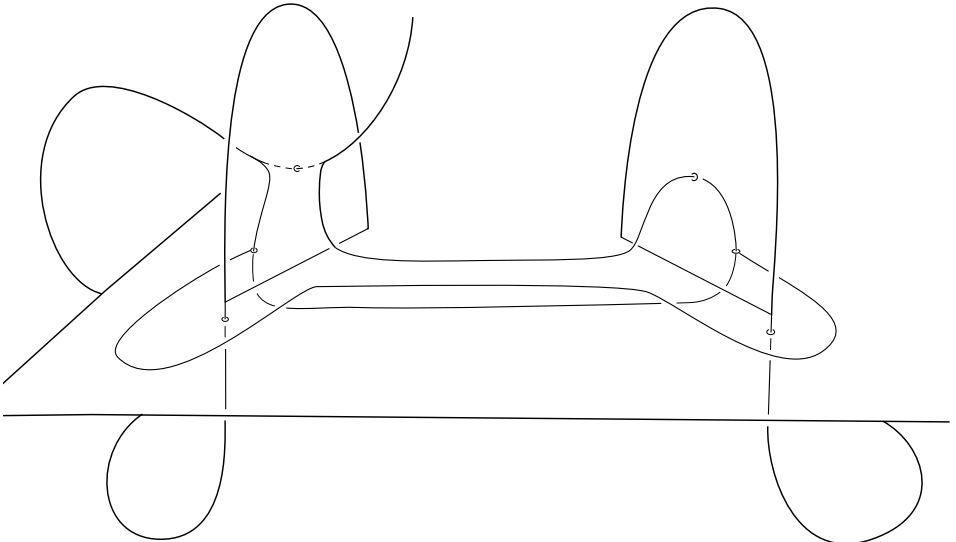

Figure 13

(i) \Rightarrow (iii) Let D_i , $i = 0, 1$, be disjoint properly immersed 2-disks in $S^3 \times I$, where $I = [0, 1]$, bounded by the knots $k_i \subset S^3 \times \{i\}$ and admitting order 1 Whitney towers \mathcal{W}_i . We may assume that the \mathcal{W}_i are disjoint, so the D_i can be tubed together by a thin embedded annulus to get an annulus A cobounded by the k_i such that A admits an order 1 Whitney tower \mathcal{W} whose Whitney disks are just the union of the Whitney disks in \mathcal{W}_i . The assumption that $\text{Arf } k_0 = \text{Arf } k_1$ means that \mathcal{W} has an even number of order 1 intersection points. By using the move illustrated in Figure 13 (details in [Yamasaki 1979], also [Schneiderman and Teichner 2001]), which does not affect framings, it can be arranged that each Whitney disk contains an even number of order 1 intersection points. After introducing an even number of (like-signed) boundary twists (2.3.2) on each Whitney disk, the order 1 intersection points on each Whitney disk occur in cancelling pairs (have opposite signs) admitting second order Whitney disks. If $2m$ boundary twists were done on a first order Whitney disk W , then the framing of W can be recovered by performing m interior twists (2.3.1), which create only second order intersection points (self-intersections of W). Having thus far constructed a second order Whitney tower, the proof of the implication (i) \Rightarrow (iii) is completed by Lemma 3.

(ii) \Leftrightarrow (iii) By Lemma 3, we may assume that the Whitney tower in (iii) is simple, thus the proof of (ii) \Leftrightarrow (iii) follows from Lemma 2. \square

References

- [Bar-Natan 1995] D. Bar-Natan, “On the Vassiliev knot invariants”, *Topology* **34**:2 (1995), 423–472. [MR 97d:57004](#) [Zbl 0898.57001](#)
- [Cochran and Teichner 2004] T. Cochran and P. Teichner, “Knot concordance and von Neumann ρ -invariants”, preprint, 2004. [math.GT/0411057](#)
- [Cochran et al. 2003] T. D. Cochran, K. E. Orr, and P. Teichner, “Knot concordance, Whitney towers and L^2 -signatures”, *Ann. of Math.* (2) **157**:2 (2003), 433–519. [MR 2004i:57003](#) [Zbl 1044.57001](#)
- [Conant and Teichner 2004a] J. Conant and P. Teichner, “Grove cobordism and Feynman diagrams”, *Math. Ann.* **328**:1-2 (2004), 135–171. [MR 2005h:57014](#) [Zbl 1054.57014](#)
- [Conant and Teichner 2004b] J. Conant and P. Teichner, “Grove cobordism of classical knots”, *Topology* **43**:1 (2004), 119–156. [MR 2004k:57006](#) [Zbl 1041.57003](#)
- [Conant et al. 2004] J. Conant, R. Schneiderman, and P. Teichner, “Jacobi relations in low-dimensional topology”, preprint, 2004.
- [Freedman and Kirby 1978] M. H. Freedman and R. Kirby, “A geometric proof of Rochlin’s theorem”, pp. 85–98 in *Algebraic and geometric topology* (Stanford, 1976), vol. 2, edited by R. J. Milgram, Proc. Sympos. Pure Math. **32**, Amer. Math. Soc., Providence, 1978. [MR 80g:57002](#) [Zbl 0392.57018](#)
- [Freedman and Quinn 1990] M. H. Freedman and F. Quinn, *Topology of 4-manifolds*, Princeton Math. Series **39**, Princeton University Press, Princeton, NJ, 1990. [MR 94b:57021](#) [Zbl 0705.57001](#)
- [Freedman and Teichner 1995] M. H. Freedman and P. Teichner, “4-manifold topology, II: Dwyer’s filtration and surgery kernels”, *Invent. Math.* **122** (1995), 531–557. [MR 96k:57016](#) [Zbl 0857.57018](#)

- [Kervaire and Milnor 1961] M. A. Kervaire and J. W. Milnor, “On 2-spheres in 4-manifolds”, *Proc. Nat. Acad. Sci. U.S.A.* **47** (1961), 1651–1657. [MR 24 #A2968](#) [Zbl 0107.40303](#)
- [Krushkal 2000] V. S. Krushkal, “Exponential separation in 4-manifolds”, *Geom. Topol.* **4** (2000), 397–405. [MR 2001i:57030](#) [Zbl 0957.57015](#)
- [Krushkal and Quinn 2000] V. S. Krushkal and F. Quinn, “Subexponential groups in 4-manifold topology”, *Geom. Topol.* **4** (2000), 407–430. [MR 2001i:57031](#) [Zbl 0954.57005](#)
- [Krushkal and Teichner 1997] V. S. Krushkal and P. Teichner, “Alexander duality, gropes and link homotopy”, *Geom. Topol.* **1** (1997), 51–69. [MR 98i:57013](#) [Zbl 0885.55001](#)
- [Magnus et al. 1976] W. Magnus, A. Karrass, and D. Solitar, *Combinatorial group theory*, 2nd ed., Dover, New York, 1976. [MR 54 #10423](#) [Zbl 0362.20023](#)
- [Matsumoto 1978] Y. Matsumoto, “Secondary intersectional properties of 4-manifolds and Whitney’s trick”, pp. 99–107 in *Algebraic and geometric topology* (Stanford, 1976), vol. 2, edited by R. J. Milgram, Proc. Sympos. Pure Math. **32**, Amer. Math. Soc., Providence, 1978. [MR 80e:57017](#) [Zbl 0394.55010](#)
- [Ng 1998] K. Y. Ng, “Groups of ribbon knots”, *Topology* **37**:2 (1998), 441–458. [MR 99e:57017](#) [Zbl 0887.57010](#)
- [Robertello 1965] R. A. Robertello, “An invariant of knot cobordism”, *Comm. Pure Appl. Math.* **18** (1965), 543–555. [MR 32 #447](#) [Zbl 0151.32501](#)
- [Schneiderman \geq 2005] R. Schneiderman, “Whitney towers and gropes in 4-manifolds”, *Trans. Amer. Math. Soc.* To appear.
- [Schneiderman and Teichner 2001] R. Schneiderman and P. Teichner, “Higher order intersection numbers of 2-spheres in 4-manifolds”, *Algebr. Geom. Topol.* **1** (2001), 1–29. [MR 2002c:57036](#) [Zbl 0964.57022](#)
- [Schneiderman and Teichner 2004] R. Schneiderman and P. Teichner, “Whitney towers and the Kontsevich integral”, pp. 101–134 in *Proceedings of a conference in honor of Andrew Casson* (Austin, TX, 2003), edited by C. Gordon and Y. Rieck, Geom. Topol. Monogr. **7**, 2004, Available at arXiv:math.GT/0401441.
- [Schneiderman and Teichner \geq 2005] R. Schneiderman and P. Teichner, “Grove concordance of classical links”. In preparation.
- [Teichner 2002] P. Teichner, “Knots, von Neumann signatures, and grope cobordism”, pp. 437–446 in *Proceedings of the International Congress of Mathematicians* (Beijing, 2002), vol. 2, edited by T. Li, Higher Ed. Press, Beijing, 2002. [MR 2004a:57012](#) [Zbl 1012.57007](#)
- [Teichner 2004] P. Teichner, “What is . . . a grope?”, *Notices Amer. Math. Soc.* **51**:8 (2004), 892–893. [Zbl pre02115096](#)
- [Whitney 1944] H. Whitney, “The self-intersections of a smooth n -manifold in $2n$ -space”, *Ann. of Math.* (2) **45** (1944), 220–246. [MR 5,273g](#) [Zbl 0063.08237](#)
- [Yamasaki 1979] M. Yamasaki, “Whitney’s trick for three 2-dimensional homology classes of 4-manifolds”, *Proc. Amer. Math. Soc.* **75**:2 (1979), 365–371. [MR 80k:57024](#) [Zbl 0412.57010](#)

Received February 24, 2004.

ROB SCHNEIDERMAN
COURANT INSTITUTE OF MATHEMATICAL SCIENCES
NEW YORK UNIVERSITY
251 MERCER STREET
NEW YORK, NY 10012-1185
UNITED STATES
schneiro@math.upenn.edu