

## Widths of surface knots

YASUSHI TAKEDA

We study surface knots in 4–space by using generic planar projections. These projections have fold points and cusps as their singularities and the image of the singular point set divides the plane into several regions. The width (or the total width) of a surface knot is a numerical invariant related to the number of points in the inverse image of a point in each of the regions. We determine the widths of certain surface knots and characterize those surface knots with small total widths. Relation to the surface braid index is also studied.

[57Q45](#); [57M25](#)

### 1 Introduction

The notion of *width* for classical knots was introduced by Gabai [8] as a generalization of the bridge index, which plays an important role in the classical knot theory. The width was useful for solving difficult problems. More precisely, we consider a generic projection  $p$  of an embedded circle in  $\mathbb{R}^3$  into the line  $\mathbb{R}$  as in Figure 1. Then non-degenerate critical points appear as its singularities and their images divide the line into several intervals. For each such interval, we consider the number of points in  $p^{-1}(x)$  for a point  $x$  in the interval, and we call it the *local width*, which does not depend on the choice of  $x$ . The width of a knot is the minimum of the total of local widths over all embedded circles representing the given knot.

By a *surface knot*, we mean (the isotopy class of) a closed connected (possibly non-orientable) smoothly embedded surface in  $\mathbb{R}^4$ . For a surface knot, Carter–Saito [5, Section 4.6] considered the analogy of the width. They applied the notion of chart for the definition of width for surface knots. A chart is a planar projection of a surface knot together with an associated graph, which was first introduced in the surface braid theory (see Kamada [12]). The graph is constructed by using a generic projection into 3–space of a surface knot. The generic projections into 3–space of surface knots have double points, triple points, and branch points as their singularities, and the charts represent the state of the combination of these singularities. Moreover, charts form several planar regions which are surrounded by curves representing double points and fold lines, and the width of a surface knot which Carter–Saito introduced is defined

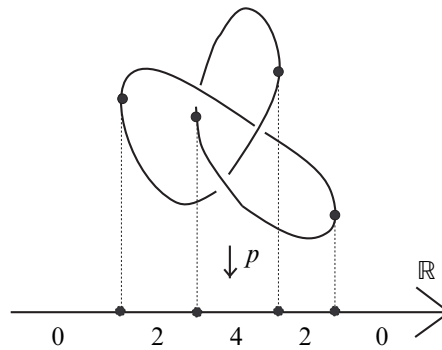

Figure 1: Local widths of an embedded circle in  $\mathbb{R}^3$

by using the number of points in the fiber over a point (local width) in each of these regions like the width for classical knots. They considered the minimum (over all representatives of the given isotopy class) of the maximum of local widths over all the regions.

However, the width which Carter–Saito defined is slightly different from the one which Gabai defined. In fact, Carter–Saito considered the maximum of local widths for the definition of width and Gabai considered the total of local widths. Moreover, the width of surface knots has not been studied so much until now as far as the author knows.

In this paper, for surface knots, we study the width defined by Carter–Saito, and the *total width* which is the straightforward analogy of the width for classical knots defined by Gabai. For this purpose, we consider generic planar projections of surface knots instead of charts. In the surface knot theory, we often use generic projections into 3–space: in fact, many results have been obtained by using projections into 3–space, and since we can view the diagrams in 3–space, they facilitate the study of surface knots. Generic planar projections have also been useful (for example, see Carrara, Carter and Saito [3], Carrara, Ruas, and Saeki [4], Saeki and Takeda [16] and Yamamoto [22]). Planar projections have fold points and cusps as their singularities. Cusps appear as discrete points and fold points appear as a 1–dimensional submanifold. Let us call the set of cusps and fold points in the surface the *singular set*. For a given surface knot, the image of the singular set divides the plane into several regions. For each such region, we consider the number of points in the pre-image of a point in that region and the maximum or the total of these numbers over all the regions. Then we take the minimum of these numbers over all embedded surfaces representing the given surface knot. Roughly speaking, this defines the width and the total width of a surface knot.

The paper is organized as follows. In [Section 2](#) we define the width and the total width of surface knots and recall the definitions of the genericity of mappings and the triviality of surface knots. In [Section 3](#) we study the width and determine the width of some surface knots such as ribbon surface knots and  $n$ -twist spun 2-bridge knots. In [Section 4](#) we consider the relationship between the width and the surface braid index and show that the width is always smaller than or equal to the twice of the surface braid index plus two. We also show that in general the difference between these two invariants can be arbitrarily large. In [Section 5](#) we give some characterization theorems of surface knots with small total widths.

Throughout the paper, we work in the smooth category.

The author would like to thank Professor Osamu Saeki for helpful suggestions and Professor Mitsuyoshi Kato for his constant encouragement. He also thanks the referee for careful reading and useful comments. The author has been supported by JSPS Research Fellowships for Young Scientists.

## 2 Preliminaries

In this section, we prepare several notions from singularity theory and define the width and the total width for surface knots in  $\mathbb{R}^4$ . For singularity theory, the reader is referred to Golubitsky and Guillemin [\[9\]](#), for example.

**Definition 2.1** Let  $F$  be a closed connected surface. Denote by  $C^\infty(F, \mathbb{R}^2)$  the set of all smooth mappings from  $F$  to  $\mathbb{R}^2$ , endowed with the Whitney  $C^\infty$  topology. Let  $f$  and  $g$  be elements of  $C^\infty(F, \mathbb{R}^2)$ . Then  $f$  is *equivalent* to  $g$  if there exist diffeomorphisms  $p: F \rightarrow F$  and  $q: \mathbb{R}^2 \rightarrow \mathbb{R}^2$  such that  $q \circ f = g \circ p$ .

**Definition 2.2** Let  $f$  be an element of  $C^\infty(F, \mathbb{R}^2)$ . Then  $f$  is said to be  *$C^\infty$  stable* if there exists a neighborhood  $N_f$  of  $f$  in  $C^\infty(F, \mathbb{R}^2)$  such that each  $g$  in  $N_f$  is equivalent to  $f$ .

**Definition 2.3** Let  $f: F \rightarrow \mathbb{R}^2$  be a smooth mapping from  $F$  to  $\mathbb{R}^2$ . Then  $q \in F$  is called a *fold point* if we can choose local coordinates  $(x, y)$  centered at  $q$  and  $(U, V)$  centered at  $f(q)$  such that  $f$ , in a neighborhood of  $q$ , is of the form:

$$U = x, \quad V = y^2.$$

Moreover,  $q \in F$  is called a *cuspidal point* if we can choose local coordinates  $(x, y)$  centered at  $q$  and  $(U, V)$  centered at  $f(q)$  such that  $f$ , in a neighborhood of  $q$ , is of the form:

$$U = x, \quad V = xy + y^3.$$

We denote by  $S_1(f)$  the set of fold points and cusps, and by  $S_1^2(f)$  the set of cusps. Note that  $S_1(f)$  is a regular 1–dimensional submanifold of  $F$  and  $S_1^2(f)$  is a discrete set.

Recall the following well-known characterization of  $C^\infty$  stable mappings in  $C^\infty(F, \mathbb{R}^2)$ .

**Proposition 2.4** *Let  $f: F \rightarrow \mathbb{R}^2$  be a smooth mapping from a closed connected surface  $F$  to  $\mathbb{R}^2$ . Then  $f$  is  $C^\infty$  stable if and only if  $f$  has only fold points and cusps as its singularities, its restriction to the set of fold points is an immersion with normal crossings, and for each cusp  $q$ , we have:*

$$f^{-1}(f(q)) \cap S_1(f) = \{q\}.$$

Let  $F$  be a closed connected surface. For a smooth map  $f: F \rightarrow \mathbb{R}^2$ , we set

$$S(f) = \{x \in F \mid \text{rank } df_x < 2\},$$

which is called the *singular point set* of  $f$ . If  $f$  is  $C^\infty$  stable, then we clearly have  $S_1(f) = S(f)$ .

The following theorem is well-known (see Thom [20]).

**Theorem 2.5** *Let  $f: F \rightarrow \mathbb{R}^2$  be a  $C^\infty$  stable mapping from a closed connected surface  $F$  to  $\mathbb{R}^2$ . Then the number of cusps of  $f$  has the same parity as the Euler characteristic  $\chi(F)$  of  $F$ .*

**Definition 2.6** Let  $f: F \rightarrow \mathbb{R}^4$  be an embedding of a closed connected surface. Let  $\pi: \mathbb{R}^4 \rightarrow \mathbb{R}^2$  be an orthogonal projection. Then we say that  $\pi$  is *generic* with respect to  $f$  (or with respect to  $f(F)$ ) if  $\pi \circ f$  is  $C^\infty$  stable.

By Mather [15], almost every orthogonal projection is generic with respect to  $f$ .

**Definition 2.7** Let  $f: F \rightarrow \mathbb{R}^4$  be an embedding of a closed connected surface  $F$ . Let  $\pi: \mathbb{R}^4 \rightarrow \mathbb{R}^2$  be an orthogonal projection which is generic with respect to  $f$ . In this case,  $\pi \circ f$  has fold points and cusps as its singularities. Let  $S(\pi \circ f) (\subset F)$  denote the set of these singularities. The singular value set  $\pi \circ f(S(\pi \circ f))$  divides the plane  $\mathbb{R}^2$  into several regions. For a point  $x$  in a given region, we call the number of elements in the set  $(\pi \circ f)^{-1}(x)$  the *local width*, which does not depend on the choice of  $x$  and is always even (see the proof of Lemma 3.2). Let  $w(f, \pi)$  (or  $w(f(F), \pi)$ ) be the maximum of the local widths over all the regions and  $tw(f, \pi)$  (or  $tw(f(F), \pi)$ )

be the total of the local widths over all the regions. The *width*  $w(f(F))$  of a surface knot  $f(F)$  is the minimum of  $w(\tilde{f}, \tilde{\pi})$ , where  $\tilde{f}$  runs over all embeddings isotopic to  $f$  and  $\tilde{\pi}$  runs over all orthogonal projections which are generic with respect to  $\tilde{f}$ . Moreover, the *total width*  $tw(f(F))$  of a surface knot  $f(F)$  is the minimum of  $tw(\tilde{f}, \tilde{\pi})$ , where  $\tilde{f}$  runs over all embeddings isotopic to  $f$  and  $\tilde{\pi}$  runs over all orthogonal projections which are generic with respect to  $\tilde{f}$ .

Let us now recall the definitions of a handlebody, the standard projective planes in  $\mathbb{R}^4$  and the normal Euler number.

An orientable *handlebody* is a compact orientable 3-manifold obtained by attaching a finite number of 1-handles to a 3-ball (the number of 1-handles may possibly be zero). A non-orientable *handlebody* is a compact non-orientable 3-manifold obtained by attaching a finite number of 1-handles to a 3-ball.

The standardly embedded projective plane in  $\mathbb{R}^4$  is constructed as in Figure 2, by attaching an unknotted disk in  $\mathbb{R}^3 \times [0, \infty)$  to a “trivially embedded” Möbius band in  $\mathbb{R}^3 \times \{0\}$ . We have two trivially embedded Möbius bands up to isotopy, and accordingly we have two kinds of standard projective planes in  $\mathbb{R}^4$ . These surface knots have normal Euler number  $\pm 2$ . Normal Euler number is an isotopy invariant of surface knots (for example, see Carter and Saito [5]).

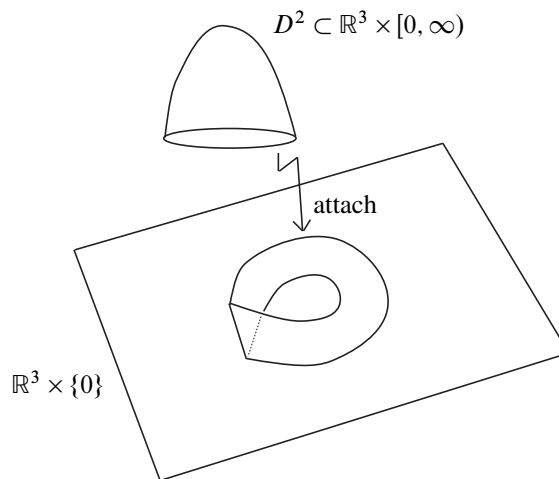

Figure 2: The standardly embedded projective plane in  $\mathbb{R}^4$

There are several definitions of trivial surface knots in the literature (for example, see Hosokawa and Kawauchi [10]). In this paper, we adopt the following definition.

**Definition 2.8** For a surface knot, we say that it is *strongly trivial* if it is the boundary of a handlebody embedded in  $\mathbb{R}^4$ . Moreover, we say that a non-orientable surface knot is *trivial* if it is the connected sum of some copies of the standardly embedded projective planes in  $\mathbb{R}^4$ , that is, the connected sum of  $k$  copies of the standardly embedded projective plane with normal Euler number  $+2$  and  $l$  copies with normal Euler number  $-2$  for some  $k \geq 0$  and  $l \geq 0$  with  $k + l \geq 1$ .

A surface knot is trivial if it is strongly trivial. However, a trivial surface knot may not necessarily be strongly trivial. In fact, if a surface knot is strongly trivial, then its Euler characteristic must be even. More precisely, a trivial surface knot is strongly trivial if and only if its normal Euler number vanishes. Furthermore, for a closed connected non-orientable surface of non-orientable genus  $g$ , the number of trivial surface knots diffeomorphic to it is equal to  $g + 1$ , and if  $g$  is even, then a strongly trivial surface knot diffeomorphic to it exists and is unique (for example, see [10]).

The following lemma is often used throughout this paper.

**Lemma 2.9** (Carrara, Ruas and Saeki [4]) *Let  $\pi: \mathbb{R}^4 \rightarrow \mathbb{R}^2$  and  $\pi_1: \mathbb{R}^2 \rightarrow \mathbb{R}$  be orthogonal projections. For an embedding  $f: F \rightarrow \mathbb{R}^4$  of a closed connected surface  $F$ , if  $\pi \circ f$  is  $C^\infty$  stable without cusps and  $\pi_1 \circ \pi \circ f: F \rightarrow \mathbb{R}$  is a Morse function<sup>1</sup> with at most four critical points, then  $f(F)$  is strongly trivial.*

### 3 Widths of certain surface knots

In this section, we characterize those surface knots with width two and determine the widths of ribbon surface knots and  $n$ -twist spun 2-bridge knots.

Let us begin by the following lemma.

**Lemma 3.1** *Let  $F$  be a closed connected surface and  $f: F \rightarrow \mathbb{R}^4$  be an embedding. Let  $\pi: \mathbb{R}^4 \rightarrow \mathbb{R}^2$  be an orthogonal projection which is generic with respect to  $f$ . Suppose that there exists a proper arc  $l$  in  $\mathbb{R}^2$  isotopic to a line in  $\mathbb{R}^2$  such that  $\pi \circ f(S(\pi \circ f))$  intersects  $l$  transversely at two points both of which are the images of fold points. Let  $N(l)$  be a tubular neighborhood of  $l$  in  $\mathbb{R}^2$  and let  $A_0$  and  $A_1$  be the connected components of  $\mathbb{R}^2 \setminus \text{Int } N(l)$ . Then there exist embeddings  $f_i: F_i \rightarrow \mathbb{R}^4$  of closed connected surfaces  $F_i$  into  $\mathbb{R}^4$ ,  $i = 0, 1$ , such that*

- (i)  $f(F)$  is isotopic to the connected sum  $f_0(F_0) \# f_1(F_1)$ ,
- (ii)  $\pi$  is generic with respect to  $f_i$ ,  $i = 0, 1$ ,

<sup>1</sup>A smooth function on a smooth manifold is a *Morse function* if its critical points are all non-degenerate.

- (iii)  $\pi \circ f_0(F_0) \cap \pi \circ f_1(F_1) = \emptyset$ ,
- (iv) for  $i = 0, 1$ , there exists a 2-disk  $D_i^2 \subset F_i$  such that
  - (iv-1)  $F_i \setminus \text{Int}D_i^2 = (\pi \circ f)^{-1}(A_i)$ ,
  - (iv-2)  $f_i|_{F_i \setminus \text{Int}D_i^2} = f|_{F_i \setminus \text{Int}D_i^2}$ ,
- (v) for  $i = 0, 1$ ,  $\pi \circ f_i|_{D_i^2}$  is a mapping as depicted in [Figure 3](#).

**Proof** Set  $l_i = \partial N(l) \cap A_i, i = 0, 1$ . Then  $(\pi \circ f)^{-1}(l_i)$  is a closed 1-dimensional manifold, and the embedding  $f|_{(\pi \circ f)^{-1}(l_i)}$  into  $\pi^{-1}(l_i) \cong \mathbb{R}^3$  is a trivial knot, since  $\pi \circ f|_{(\pi \circ f)^{-1}(l_i)}: (\pi \circ f)^{-1}(l_i) \rightarrow l_i \cong \mathbb{R}$  is a Morse function with one maximum and one minimum. Therefore,  $f((\pi \circ f)^{-1}(l_i))$  bounds a 2-disk  $\Delta_i^2$  in  $\pi^{-1}(l_i), i = 0, 1$ . We slightly push the interior of the 2-disk into  $\pi^{-1}(\text{Int}N(l))$  and we denote it by  $\tilde{\Delta}_i^2$ . Then we get the desired embeddings  $f_i: F_i = (\pi \circ f)^{-1}(A_i) \cup D_i^2 \rightarrow \mathbb{R}^4, i = 0, 1$ , such that  $f_i|_{(\pi \circ f)^{-1}(A_i)} = f|_{(\pi \circ f)^{-1}(A_i)}$  and  $f_i(D_i^2) = \tilde{\Delta}_i^2$ .  $\square$

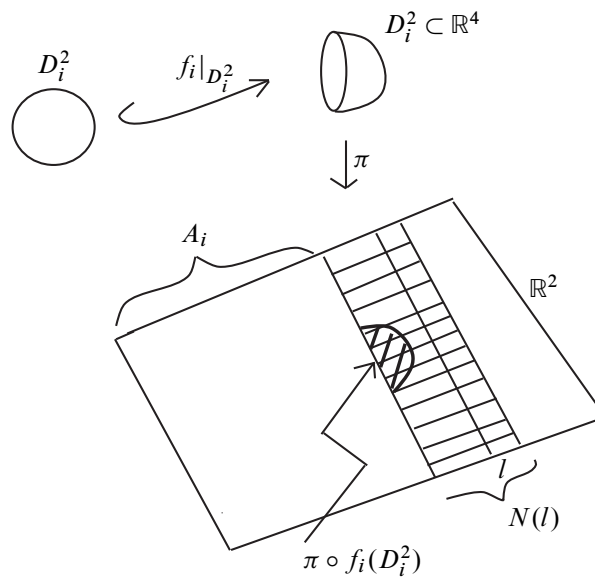

Figure 3: The mapping  $\pi \circ f_i|_{D_i^2}$

Let  $f: F \rightarrow \mathbb{R}^4$  be an embedding of a closed connected surface  $F$  and  $\pi: \mathbb{R}^4 \rightarrow \mathbb{R}^2$  be an orthogonal projection which is generic with respect to  $f$ . Then  $\pi \circ f(S(\pi \circ f))$  has fold crossings and cusps. We have four regions locally near a fold crossing, and we have two regions locally near a cusp.

**Lemma 3.2** Let  $f: F \rightarrow \mathbb{R}^4$  be an embedding of a closed connected surface  $F$  and  $\pi: \mathbb{R}^4 \rightarrow \mathbb{R}^2$  be an orthogonal projection which is generic with respect to  $f$ . Then, the local widths around a fold crossing of  $\pi \circ f(S(\pi \circ f))$  are of the forms  $n, n+2, n+2, n+4$  for some  $n \geq 0$  even. The local widths around the image of a cusp are of the forms  $n, n+2$  for some  $n \geq 2$  even. See Figure 4.

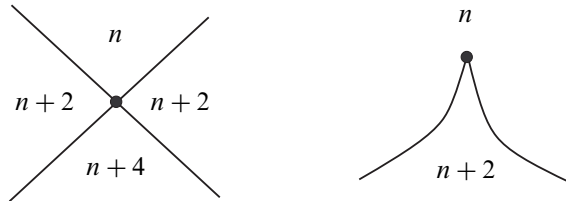

Figure 4: Local widths around a fold crossing (left) and around a cusp (right)

**Proof** If a point  $x \in \mathbb{R}^2$  crosses the image of a fold curve, then the number of elements in the inverse image  $(\pi \circ f)^{-1}(x)$  changes by  $\pm 2$ . Furthermore, since  $F$  is compact,  $\pi \circ f$  is not surjective, and the local width for the unbounded region must be zero. Therefore, the local width of each region should be an even number.

Let  $x \in \mathbb{R}^2$  be a fold crossing. Then the mapping  $\pi \circ f$  near  $(\pi \circ f)^{-1}(x)$  is easily seen to be equivalent to the mapping as depicted in Figure 5 for some  $n \geq 0$ . Furthermore, each local width should be even. Therefore, the desired conclusion follows.

For a cusp, the situation is as depicted in Figure 6 for some  $n$ . Since the mapping  $\pi \circ f$  near a cusp point is an open map, each local width around the image of a cusp should be positive. Then, the desired conclusion follows. This completes the proof.  $\square$

Let us give a characterization of surface knots with width two.

**Theorem 3.3** Let  $F \subset \mathbb{R}^4$  be a surface knot. Then  $w(F) = 2$  if and only if  $F$  is strongly trivial.

**Proof** Suppose that  $w(F) = 2$ . We may assume that for an orthogonal projection  $\pi: \mathbb{R}^4 \rightarrow \mathbb{R}^2$  which is generic with respect to  $F$ , we have  $w(F, \pi) = w(i, \pi) = 2$ , where  $i: F \rightarrow \mathbb{R}^4$  is the inclusion mapping. Then the local width of each region of  $\mathbb{R}^2 \setminus \pi(S(\pi \circ i))$  must be equal to 0 or 2. Therefore, by Lemma 3.2 there are no fold crossings nor cusps. Since  $F$  is connected, we see that the image of the singular set  $S(\pi|_F)$  must be as depicted in Figure 7 up to isotopy of  $\mathbb{R}^2$ . Then by using Lemma 3.1, we see that either (i)  $F$  is isotopic to a connected sum  $F_1 \# F_2 \# \cdots \# F_r$  for some



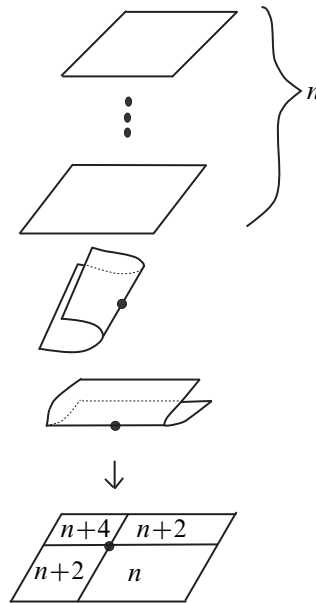

Figure 5: The situation near a fold crossing

$r \geq 1$  such that  $\pi$  is generic with respect to  $F_j$  and the image of the singular set  $S(\pi|_{F_j})$  is as depicted in Figure 8 up to isotopy of  $\mathbb{R}^2$ ,  $j = 1, 2, \dots, r$ , or (ii) the image of the singular set  $S(\pi|_F)$  is as depicted in Figure 9 up to isotopy of  $\mathbb{R}^2$ . In case (i), each  $F_j$  is strongly trivial by Lemma 2.9. Therefore,  $F$  is also strongly trivial. In case (ii),  $F$  is strongly trivial by Lemma 2.9. Conversely, if  $F$  is strongly trivial, then we see easily that  $w(F) = 2$ . This completes the proof.  $\square$

Let us recall the notion of a ribbon surface knot, which plays an important role in the theory of surface knots (Cochran, Kamada, Kawachi, Tanaka and Yasuda [6; 11; 13; 18; 23]).

**Definition 3.4** Let  $A = A_1 \cup A_2 \cup \dots \cup A_k$  (or  $B = B_1 \cup B_2 \cup \dots \cup B_l$ ) denote a finite disjoint collection of 3–balls embedded in  $\mathbb{R}^4$ . Parametrize each component  $B_i$  of  $B$  as  $b_i: D^2 \times [0, 1] \rightarrow \mathbb{R}^4$ . Suppose that for each  $i = 1, 2, \dots, l$ , we have

- (i)  $\partial A \cap b_i(D^2 \times [0, 1]) = b_i(D^2 \times \{0, 1\})$ , and
- (ii)  $b_i(D^2 \times (0, 1)) \cap A = b_i(D^2 \times I_i)$  for a finite set  $I_i \subset (0, 1)$ .

Then the surface knot

$$F = \left( \partial A \setminus \cup_{i=1}^l b_i(D^2 \times \{0, 1\}) \right) \cup \cup_{i=1}^l b_i(\partial D^2 \times [0, 1])$$

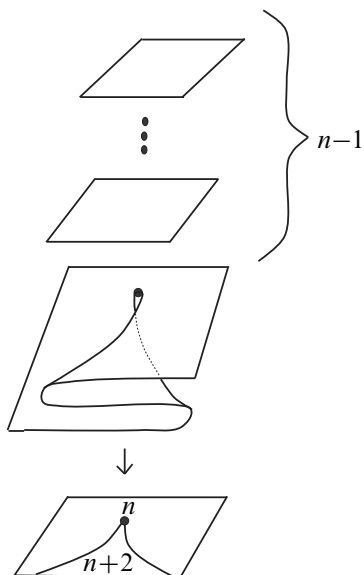

Figure 6: The situation near a cusp

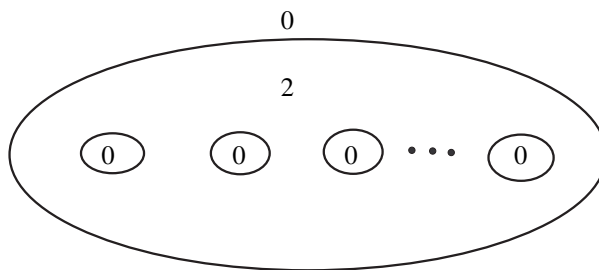

Figure 7: The image of the singular set of a surface knot  $F$  with  $w(F) = 1$

(after a suitable smoothing) is called a *ribbon surface knot* if  $F$  is connected.

Note that a surface knot which is strongly trivial is a ribbon surface knot. If a ribbon surface knot is non-orientable, then the genus must be even.

**Proposition 3.5** *Let  $F \subset \mathbb{R}^4$  be a ribbon surface knot which is not strongly trivial. Then we have  $w(F) = 4$ .*

**Proof** By isotopy of  $F$  we may assume that

$$A_j = \{(x_1, x_2, x_3, x_4) \in \mathbb{R}^4 \mid x_1 = 0, x_2^2 + x_3^2 + (x_4 - j)^2 \leq (1/4)^2\}, \quad j = 1, 2, \dots, k.$$

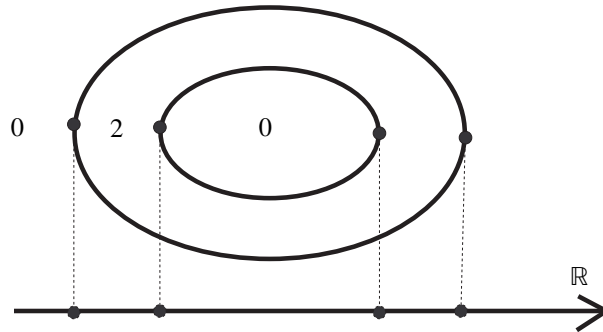

Figure 8: The image of the singular set  $S(\pi|_{F_j})$

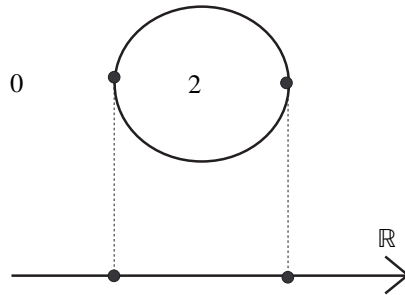

Figure 9: The image of the singular set  $S(\pi|_F)$

We define  $\pi: \mathbb{R}^4 \rightarrow \mathbb{R}^2$  by  $\pi(x_1, x_2, x_3, x_4) = (x_3, x_4)$ . Then  $\pi$  is generic for  $\partial A_j$  and  $\pi(S(\pi|_{\partial A_j}))$  is as depicted in Figure 10. Moreover, we may further assume that each  $b_i|_{\{0\} \times [0,1]}$  satisfies  $b_i(0,0), b_i(0,1) \in S(\pi|_{\partial A})$  and  $b_i|_{\{0\} \times I_\varepsilon}$  is an embedding into the closure of  $\{(0,0,x_3,x_4) \in \mathbb{R}^4\} \setminus A$ , where  $I_\varepsilon = [0,\varepsilon) \cup (1-\varepsilon,1]$  and  $\varepsilon > 0$  is sufficiently small. We define

$$b: \coprod_{i=1}^l (D^2 \times [0,1])_i \rightarrow \mathbb{R}^4$$

by  $b(x) = b_i(x), x \in (D^2 \times [0,1])_i$ , where  $(D^2 \times [0,1])_i$  is a copy of  $D^2 \times [0,1]$ ,  $i = 1, 2, \dots, l$ .

We may assume that  $\pi \circ b$  restricted to  $\coprod_{i=1}^l (\{0\} \times [0,1])_i$  is an immersion with normal crossings. Furthermore, by pushing the crossings out of  $\pi(A)$  one by one by an isotopy

of  $F$ , we may assume that  $\pi(A)$  does not contain any double point of  $\pi \circ b$  restricted to  $\coprod_{i=1}^l (\{0\} \times [0, 1])_i$  (see Figure 11).

Now the fiber of the normal disk bundle to  $b_i(\{0\} \times [0, 1])$  in  $\mathbb{R}^4$  is a 3-dimensional disk. If we fix  $b_i(\{0\} \times [0, 1])$ , then the isotopy class of  $b_i(D^2 \times [0, 1])$  is determined by the homotopy class of a unit normal vector field along  $b_i(\{0\} \times [0, 1])$ , which corresponds to the unit normal vector to  $b_i(D^2 \times \{*\})$  in the 3-dimensional disk fiber. Therefore, we may assume that the tangent plane to  $b_i(D^2 \times \{t\})$  at  $b_i(\{0\} \times \{t\})$  is not parallel to the fibers of  $\pi: \mathbb{R}^4 \rightarrow \mathbb{R}^2, t \in [0, 1]$ .

By taking  $B = \coprod_{i=1}^l b_i(D^2 \times [0, 1])$  “thin” enough, we may then assume that  $S(\pi \circ b_i|_{\partial D^2 \times [0, 1]})$  consists exactly of two arcs for each  $i$ . Now  $\pi(S(\pi|_F))$  is as depicted in Figure 12 and we see that the local width of each region is equal to 0, 2 or 4. Therefore, we have  $w(F) \leq 4$ . Then by Theorem 3.3, the desired conclusion follows. This completes the proof.  $\square$

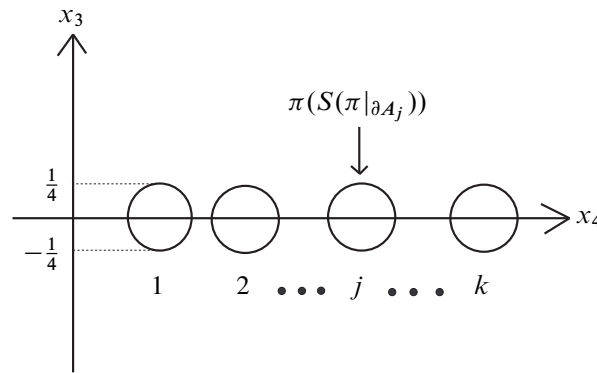

Figure 10:  $\pi(S(\pi|_{A_j}))$

Let us recall the notion of bridge index for classical knots. Here, we give a definition suitable for our purpose.

**Definition 3.6** Let  $K$  be a classical knot and  $\pi: \mathbb{R}^3 \rightarrow \mathbb{R}$  a generic orthogonal projection. Let  $m(K, \pi)$  be the number of local maxima of  $\pi|_K: K \rightarrow \mathbb{R}$ . Then the *bridge index*  $b(K)$  of  $K$  is defined to be the minimum of  $m(\tilde{K}, \tilde{\pi})$ , where  $\tilde{K}$  runs through all embeddings of  $S^1$  into  $\mathbb{R}^3$  isotopic to  $K$ , and  $\tilde{\pi}$  runs through all orthogonal projections  $\mathbb{R}^3 \rightarrow \mathbb{R}$  generic with respect to  $\tilde{K}$ . A knot having bridge index  $n$  is called an  $n$ -bridge knot.

Note that an orthogonal projection  $\pi: \mathbb{R}^3 \rightarrow \mathbb{R}$  is *generic with respect to*  $K$  if  $\pi|_K: K \rightarrow \mathbb{R}$  has only non-degenerate critical points as its singularities.

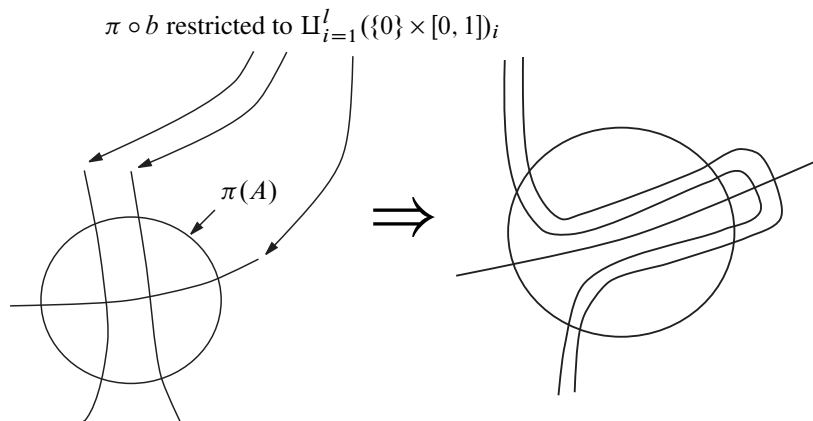

Figure 11: Pushing the crossings of  $\pi \circ b$  restricted to  $\Pi_{i=1}^l(\{0\} \times [0, 1])_i$  out of  $\pi(A)$

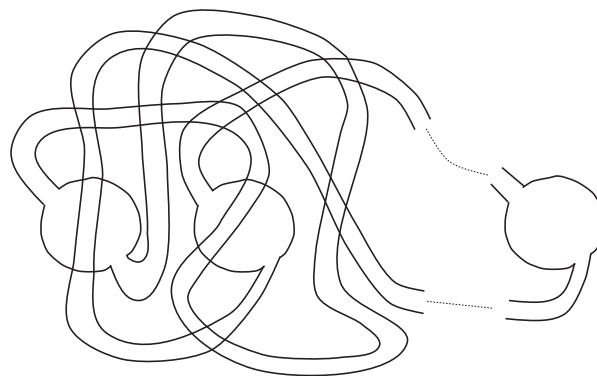

Figure 12:  $\pi(S(\pi|_F))$

**Definition 3.7** Let  $\mathbb{R}_+^3$  be the 3-dimensional upper half-space, ie,

$$\mathbb{R}_+^3 = \{(x_1, x_2, x_3, x_4) \mid x_3 \geq 0, x_4 = 0\}$$

and  $\mathbb{R}^2$  the plane  $\mathbb{R}^2 = \{(x_1, x_2, x_3, x_4) \mid x_3 = 0, x_4 = 0\}$ . Let  $k$  be an arc properly embedded in the half-space  $\mathbb{R}_+^3$ . When the half-space is rotated around the plane  $\mathbb{R}^2$  in  $\mathbb{R}^4$ , the continuous trace of  $k$  forms a 2-sphere. This 2-sphere is said to be derived from  $k$  by (untwisted) spinning, and we call the resulting surface knot a *spun knot*. Moreover, put the knotted part of  $k$  in a 3-ball as in Figure 13 and twist it  $n$  times,  $n \in \mathbb{Z}$ , as the half-space spins once around  $\mathbb{R}^2$ . Then we call the resulting surface knot

an  $n$ -twist spun knot. In general,  $k$  is associated with a knot in  $\mathbb{R}^3$ , which is obtained by connecting the end points of  $k$  in an obvious way by an arc in  $\mathbb{R}^2$ . See also Zeeman [24].

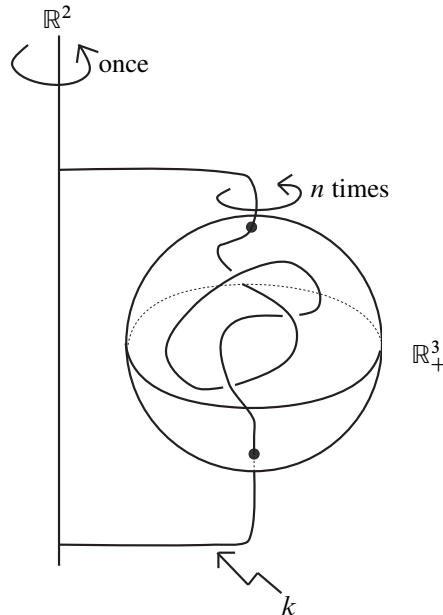

Figure 13: The  $n$ -twist spun trefoil

**Proposition 3.8** *Let  $F \subset \mathbb{R}^4$  be an  $n$ -twist spun 2-bridge knot with  $n \neq \pm 1$ . Then we have  $w(F) = 4$ .*

**Proof** Let  $K$  be a 2-bridge knot and  $\pi: \mathbb{R}^3 \rightarrow \mathbb{R}$  the orthogonal projection defined by  $\pi(x_1, x_2, x_3) = x_3$ . Then there exists a knot  $K'$  isotopic to  $K$  such that  $\pi$  is generic for  $K'$  and  $\pi|_{K'}$  has two local minima  $a_0, a_1$  and two local maxima  $a_2, a_3$  with  $a_0 < 0 < a_1 < a_2 < a_3$ . We may assume that the values of the local maxima and the local minima are all distinct and that  $K'$  is in a position as described in Figure 14. Rotate the part  $K' \cap \mathbb{R}_+^3 = K' \cap \{x_3 \geq 0, x_4 = 0\}$  around  $\mathbb{R}^2 = \{x_3 = x_4 = 0\}$  in  $\mathbb{R}^4$ . Then we get the 0-twist spun  $F_0$  of  $K$ . The orthogonal projection  $\tilde{\pi}: \mathbb{R}^4 \rightarrow \mathbb{R}^2$  defined by  $\tilde{\pi}(x_1, x_2, x_3, x_4) = (x_3, x_4)$  is generic for  $F_0$  and  $\tilde{\pi}(S(\tilde{\pi}|_{F_0}))$  is as depicted in Figure 15. Therefore, we have  $w(F_0) \leq 4$ . For the  $n$ -twist spun  $F_n$  of  $K$ , rotate  $K' \cap \mathbb{R}_+^3$  around  $\mathbb{R}^2$  once and twist the “knotted part”  $n$  times. Then  $\pi|_{K'}$  does not change and the image of the singular set is again as depicted in Figure 15. Therefore, we

have  $w(F_n) \leq 4$ . If  $w(F_n) = 2$ , then by [Theorem 3.3](#)  $F_n$  is strongly trivial. However, for  $n \neq \pm 1$ , it is known that  $F_n$  is not strongly trivial (Cochran [\[6\]](#)). Therefore, we have  $w(F_n) = 4$  for  $n \neq \pm 1$ .  $\square$

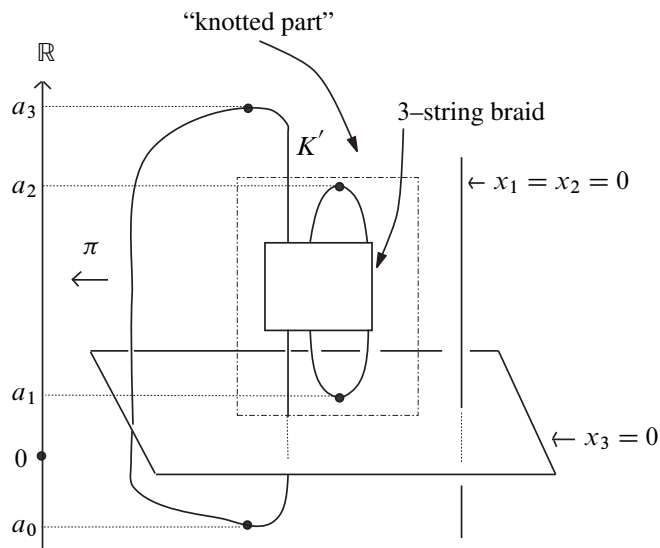

Figure 14: Bridge presentation

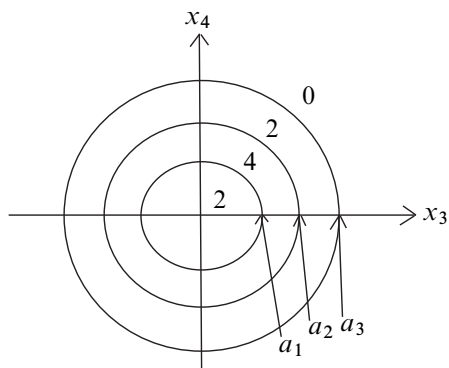

Figure 15: A planar projection of a 0-twist spun 2-bridge knot and the associated local widths

**Remark 3.9** By an argument similar to that in the proof of [Proposition 3.8](#), we can show that the width of an  $n$ -twist spun  $m$ -bridge knot is smaller than or equal to  $2m$ .

However, even if  $n \neq \pm 1$ , the equality may not hold. In fact, for every knot, its 0–twist spun is a ribbon surface knot (see, for example, [6]). Hence, by Proposition 3.5, we have  $4 = w(F) < 2m$  if  $F$  is a 0–twist spun  $m$ –bridge knot with  $m \geq 3$ .

## 4 Braid index and width

In this section, we study the relationship between the braid index and the width of a surface knot. Throughout this section, we assume that surface knots are orientable.

The notion of surface braid was introduced by Kamada [12]. Kamada and Viro showed that every orientable surface knot is isotopic to a simple closed surface braid.

A *closed surface braid* in  $D^2 \times S^2 \subset (D^2 \times S^2) \cup (D^3 \times S^1) = S^4$  is a closed oriented surface  $F$  embedded in  $D^2 \times S^2$  such that the restriction map  $pr_2|_F: F \rightarrow S^2$  of the projection  $pr_2: D^2 \times S^2 \rightarrow S^2$  to the second factor is an orientation preserving branched covering. We say that it is a *simple* closed surface braid if  $pr_2|_F$  is a simple branched covering. An orientation preserving branched covering  $f: F \rightarrow M$  between closed oriented surfaces is *simple* if for every branch point  $y \in M$ , we have  $\#f^{-1}(y) = \deg(f) - 1$ , where  $\#$  denotes the number of elements and  $\deg(f) > 0$  is the mapping degree of  $f$ . The mapping degree of  $pr_2|_F: F \rightarrow S^2$  is called the *degree* of the closed surface braid.

The *braid index*  $\text{Braid}(F)$  of an oriented surface knot  $F$  in  $\mathbb{R}^4$  is the minimum degree of simple closed surface braids in  $S^4 = \mathbb{R}^4 \cup \{\infty\}$  that are isotopic to  $F$ .

For classical knots, the bridge index is smaller than or equal to the braid index. On the other hand, the relation between the width and the braid index for classical knots has not been studied as far as the author knows.

For surface knots, we have the following.

**Proposition 4.1** *Let  $F \subset \mathbb{R}^4$  be an orientable surface knot. Then we have*

$$w(F) \leq 2(\text{Braid}(F) + 1).$$

**Proof** Let  $S^2 \subset \mathbb{R}^4$  be the standard 2–sphere, ie,  $S^2 = \{(x_1, x_2, x_3, x_4) \in \mathbb{R}^4 \mid x_1 = 0, x_2^2 + x_3^2 + x_4^2 = 1\}$ , and  $D^2 \times S^2$  be its tubular neighborhood. We may assume that  $F \subset D^2 \times S^2$  and the restriction  $pr_2|_F$  of  $pr_2: D^2 \times S^2 \rightarrow S^2$  is a simple branched covering of degree equal to  $\text{Braid}(F)$ . We may further assume that the critical values of  $pr_2|_F$  all lie near  $(0, 1, 0, 0) \in S^2$  and that outside of the pre-image of a neighborhood of  $(0, 1, 0, 0)$ ,  $F$  is almost parallel to  $S^2$ . Let us define the orthogonal



projection  $\pi: \mathbb{R}^4 \rightarrow \mathbb{R}^2$  by  $\pi(x_1, x_2, x_3, x_4) = (x_3, x_4)$ . Then, we may assume that the image of the singular points of  $\pi|_F$  is as depicted in Figure 16.

Let  $y \in S^2$  be a branch point of  $g = pr_2|_F$  and let  $x \in F$  be the branch point such that  $y = g(x)$ . Furthermore, let  $B \cong I \times J$  be a small neighborhood of  $y$  in  $S^2$ , where  $I = J = [-1, 1]$  and  $y$  corresponds to  $(0,0)$ , and let  $\tilde{B}$  be the component of  $g^{-1}(B)$  which contains  $x$ . Set  $J_t = \{t\} \times J \subset I \times J$  for  $t \in I$ . Then  $(g|_{\tilde{B}})^{-1}(J_t) \subset pr_2^{-1}(J_t) \cong D^2 \times J$  can be regarded as a 2–string braid for  $t \neq 0$ . See Figure 17 (1).

Then we deform  $F$  (or more precisely, we deform  $\tilde{B}$ ) by an isotopy in  $\mathbb{R}^4$  so that this sequence of 2–string braids is deformed as in Figure 17 (2). Note that then  $\pi$  is generic on  $\tilde{B}$  and the image of the singular points in  $B \cong I \times J$  is as depicted in Figure 17 (3). Three cusps are created, while the branch point in question is eliminated.

We perform the above described deformation for each branch point of  $g$ . Then we get a surface  $\tilde{F}$  isotopic to  $F$  such that  $\pi$  is generic with respect to  $\tilde{F}$  and that the singular values of  $\pi|_{\tilde{F}}$  and the local widths are as depicted in Figure 18, where  $b = \text{Braid}(F)$ . Therefore, we have  $w(F) \leq 2(b + 1)$ . This completes the proof.  $\square$

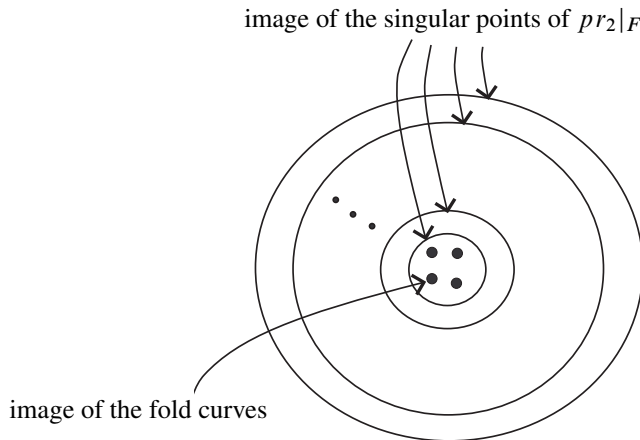

Figure 16: Image of the singular points of  $\pi|_F$

Let us consider a branch point of a surface braid as above. Since it is simple, there may be a “sheet” of  $F$  over that point which does not intersect a neighborhood of the corresponding branch point in  $F$ . If the sheet can be deformed as depicted in Figure 19, then the width decreases by 2. Therefore, the following conjecture seems to be plausible.

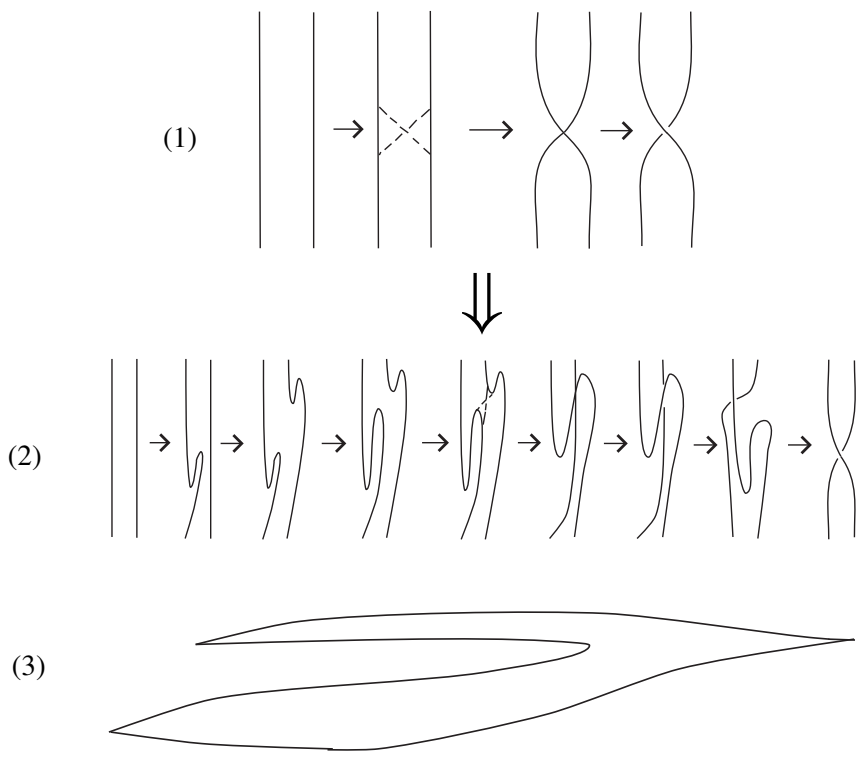

Figure 17: Deformation of a branch point

**Conjecture 4.2** *Let  $F \subset \mathbb{R}^4$  be an orientable surface knot. Then we have*

$$w(F) \leq 2\text{Braid}(F).$$

By the following proposition, the difference between the width and (twice) the braid index can be arbitrarily large.

**Proposition 4.3** *For every  $n \geq 3$ , there exists a surface knot  $F$  in  $\mathbb{R}^4$  with  $\text{Braid}(F) = n$  and  $w(F) = 4$ .*

For the proof, we need the following.

**Lemma 4.4** *For surface knots  $F_1$  and  $F_2$  in  $\mathbb{R}^4$ , we always have*

$$w(F_1 \# F_2) \leq \max\{w(F_1), w(F_2)\}.$$

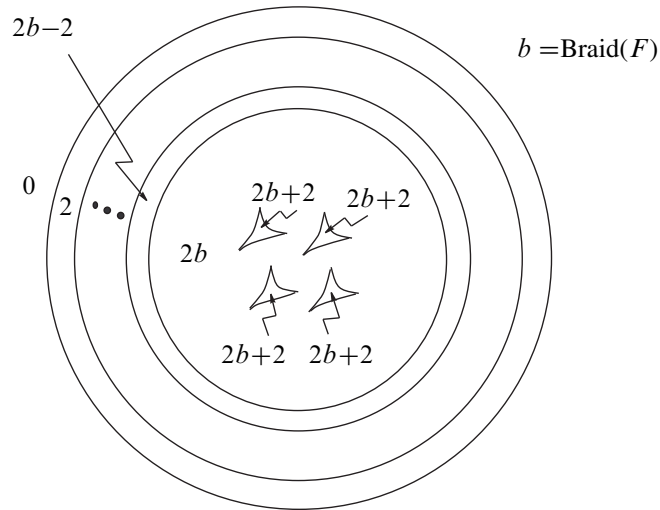
Figure 18: Image of  $S(\pi|_{\bar{F}})$  by  $\pi$  and local widths

**Proof** We may assume that there exists an orthogonal projection  $\pi: \mathbb{R}^4 \rightarrow \mathbb{R}^2$  which is generic with respect to both  $F_1$  and  $F_2$  such that  $w(F_1, \pi) = w(F_1)$  and  $w(F_2, \pi) = w(F_2)$ . We may further assume that  $\pi(F_1) \cap \pi(F_2) = \emptyset$ . Let us consider fold points of  $\pi|_{F_1}$  and  $\pi|_{F_2}$  whose images by  $\pi$  lie in the outermost boundaries of  $\pi(F_1)$  and  $\pi(F_2)$  respectively. If we perform the connected sum operation using small disk neighborhoods of these fold points and by connecting  $F_1$  and  $F_2$  by an appropriate cylinder (see the proof of [Proposition 3.5](#)), then  $\pi$  is generic with respect to  $F_1 \# F_2$  and  $w(F_1 \# F_2, \pi) = \max\{w(F_1, \pi), w(F_2, \pi)\}$ . Thus the conclusion follows. This completes the proof.  $\square$

**Remark 4.5** The referee kindly pointed out that there is an example for which the equality does not hold in [Lemma 4.4](#) as follows. By Viro [\[21\]](#), it is known that there exists a ribbon 2-sphere knot  $F \subset \mathbb{R}^4$ , which is not strongly trivial, such that  $F \# P_+$  is isotopic to  $P_+$ , where  $P_+$  is the trivial projective plane with normal Euler number 2. Let  $K \subset \mathbb{R}^4$  be a Klein bottle knot, which is strongly trivial, such that  $P_+ \# P_-$  is isotopic to  $K$ , where  $P_-$  is the trivial projective plane with normal Euler number  $-2$ . Then  $F \# K$  is isotopic to  $K$ . Since  $w(F) = 4$ ,  $w(K) = 2$  and  $w(F \# K) = 2$ , the equality does not hold in [Lemma 4.4](#). However, we do not know such an example if both  $F_1$  and  $F_2$  are orientable. The author would like to thank the referee for pointing out this example.

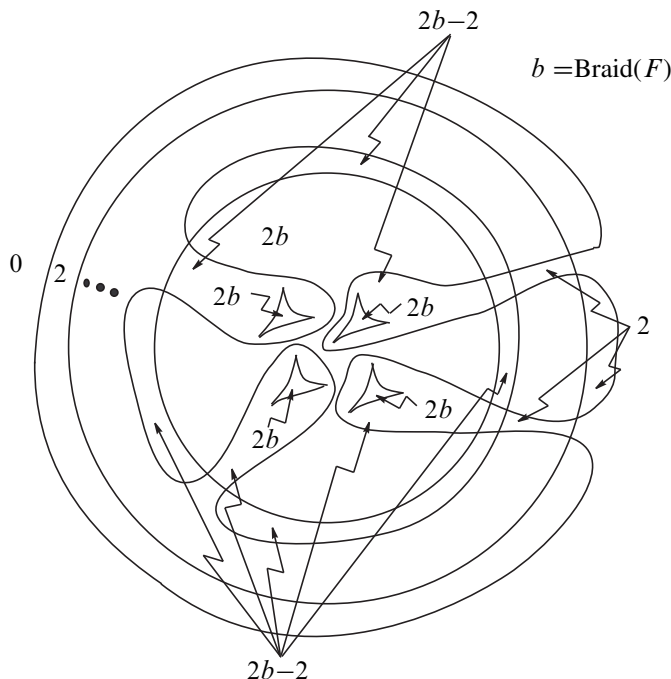

Figure 19: A possible deformation of neighborhoods of the corresponding branch points in  $F$

**Proof of Proposition 4.3** Let  $F_1$  be the spun  $(2, p)$ -torus knot, where  $p$  is an odd integer with  $p \geq 3$ . Furthermore, let  $F$  be the connected sum of  $n - 2$  copies of  $F_1$ . Then by Tanaka [19], we have  $\text{Braid}(F) = n$ . On the other hand, since the  $(2, p)$ -torus knot is a 2-bridge knot, we have  $w(F_1) = 4$  by Proposition 3.8. Then by Lemma 4.4, we have  $w(F) \leq 4$ . Since  $\text{Braid}(F) = n \geq 3$ ,  $F$  is not strongly trivial, and hence  $w(F) > 2$  by Theorem 3.3. Therefore, we have  $w(F) = 4$ . This completes the proof.  $\square$

### 5 Total widths of surface knots

In this section, we give several characterization theorems of surface knots with small total widths.

The following is an immediate consequence of Theorem 3.3.

**Theorem 5.1** *Let  $F \subset \mathbb{R}^4$  be a surface knot. Then  $tw(F) = 2$  if and only if it is strongly trivial.*

Let  $f: F \rightarrow \mathbb{R}^2$  be a  $C^\infty$  stable mapping of a closed surface into the plane. For a point  $x \in S(f) \setminus S_1^2(f)$ , we give a local orientation of  $S(f)$  at  $x$  as follows. For a sufficiently small disk neighborhood  $\Delta$  of  $f(x)$  in  $\mathbb{R}^2$ ,  $\Delta \cap f(S(f))$  is an arc and  $\Delta \setminus f(S(f))$  consists of two regions. Let us take points, say  $y_1$  and  $y_2$ , from each of the two regions. We may assume that the number of elements in the inverse image  $f^{-1}(y_1)$  is greater than that of  $f^{-1}(y_2)$ . Then we orient  $\Delta \cap f(S(f))$  so that the left hand side region corresponds to  $y_1$ . Finally we give a local orientation of  $S(f)$  at  $x$  so that  $f|_{S(f)}$  preserves the orientation around  $x$ . See Figure 20.

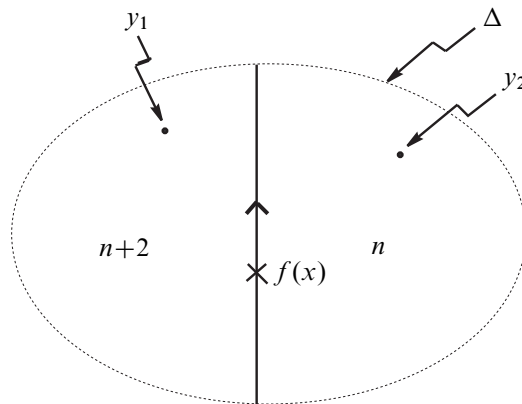

Figure 20: Local orientation

It is easy to see that the above local orientations vary continuously and that they define a globally well-defined orientation on  $S(f)$ .

On the other hand, by considering the “line”  $df_x(T_x S(f))$  for each  $x \in S(f) \setminus S_1^2(f)$ , we obtain a smooth mapping  $S(f) \setminus S_1^2(f) \rightarrow \mathbb{R}P^1$ . It is not difficult to see that this mapping extends to a smooth mapping  $\tau_f: S(f) \rightarrow \mathbb{R}P^1$ . We orient  $\mathbb{R}P^1$  so that the lines rotating in the counter-clockwise direction correspond to the positive direction of  $\mathbb{R}P^1$ .

Then we define  $\text{rot}(f)$  to be the mapping degree of  $\tau_f: S(f) \rightarrow \mathbb{R}P^1$ .

Then the following lemma is proved in Levine [14].

**Lemma 5.2** *The Euler characteristic  $\chi(F)$  of  $F$  coincides with  $\text{rot}(f)$ .*

Using Lemma 5.2, we prove the following.

**Theorem 5.3** *Let  $F \subset \mathbb{R}^4$  be a surface knot which is diffeomorphic to the 2–sphere  $S^2$ . Then  $tw(F) \leq 6$  if and only if it is strongly trivial.*

**Proof** If  $tw(F) = 2$ , then by [Theorem 5.1](#),  $F$  is strongly trivial. Furthermore, there does not exist a surface knot  $F$  with  $tw(F) = 4$ , since  $F$  is connected. Therefore, we may assume  $tw(F) = 6$  and there exists an orthogonal projection  $\pi: \mathbb{R}^4 \rightarrow \mathbb{R}^2$  which is generic with respect to  $F$  such that  $tw(F, \pi) = tw(F)$ .

If  $\pi(S(\pi|_F))$  has no fold crossings, then it is of the form “Type A” as depicted in [Figure 21](#) up to isotopy of  $\mathbb{R}^2$ . Then, by [Lemma 3.1](#),  $F$  is the connected sum of surface knots  $F_1$  and  $F_2$  such that  $\pi(S(\pi|_{F_1}))$  (or  $\pi(S(\pi|_{F_2}))$ ) is of the form “Type B” (resp. “Type C”) as depicted in [Figure 21](#) up to isotopy of  $\mathbb{R}^2$ . Since  $F$  is diffeomorphic to the 2–sphere, so are  $F_1$  and  $F_2$ . Then, by [Lemma 5.2](#), Type B and Type C must correspond to Type D and Type E of [Figure 21](#) respectively. By [Lemma 2.9](#), we see that  $F_1$  is strongly trivial. Furthermore, there exists an orthogonal projection  $\pi_1^4: \mathbb{R}^4 \rightarrow \mathbb{R}^1$  which is generic with respect to  $F_2$  such that  $\pi_1^4|_{F_2}$  has exactly two critical points. In fact, such a projection can be obtained by composing  $\pi: \mathbb{R}^4 \rightarrow \mathbb{R}^2$  and a suitable projection  $\mathbb{R}^2 \rightarrow \mathbb{R}^1$  (for example, see Fukuda [\[7\]](#)). Thus,  $F_2$  is also strongly trivial, and hence so is  $F = F_1 \sharp F_2$ .

If  $\pi(S(\pi|_F))$  has one fold crossing, then it is of the form “Type A” as depicted in [Figure 22](#) or in [Figure 23](#) up to isotopy of  $\mathbb{R}^2$ . Then, by [Lemma 3.1](#),  $F$  is the connected sum of surface knots  $F_1$  and  $F_2$  such that  $\pi(S(\pi|_{F_1}))$  (or  $\pi(S(\pi|_{F_2}))$ ) is of the form “Type B” (resp. “Type C”) as depicted in [Figure 22](#) or in [Figure 23](#) up to isotopy of  $\mathbb{R}^2$ . Since  $F$  is diffeomorphic to the 2–sphere, so are  $F_1$  and  $F_2$ . Then, by [Lemma 5.2](#), Type B and Type C must correspond to Type D and Type E of [Figure 22](#) or [Figure 23](#) respectively. By [Lemma 2.9](#),  $F_1$  is strongly trivial. Furthermore, there exists an orthogonal projection  $\pi_1^4: \mathbb{R}^4 \rightarrow \mathbb{R}^1$  which is generic with respect to  $F_2$  such that  $\pi_1^4|_{F_2}$  has exactly four critical points. Therefore,  $F_2$  is strongly trivial by Scharlemann [\[17\]](#). (In fact, “Type E” of [Figure 23](#) does not occur by Akhmet’ev [\[1, 23, Corollary.\]](#)) Thus,  $F = F_1 \sharp F_2$  is strongly trivial.

If  $\pi(S(\pi|_F))$  has two fold crossings, then it is of the form “Type A” as depicted in [Figure 24](#) or as depicted in [Figure 25](#). In the former case, we see that  $F$  is strongly trivial as before (see [Figure 24](#)). In the latter case, we see that  $\chi(F) < \chi(S^2)$  by [Lemma 5.2](#), which is a contradiction. Thus, this case does not occur.

If  $\pi(S(\pi|_F))$  has three or more fold crossings, then it is of the form as depicted in [Figure 26](#). Then, we see that  $\chi(F) < \chi(S^2)$  by [Lemma 5.2](#), so that this case does not occur.

Hence  $F$  is always strongly trivial. This completes the proof.  $\square$

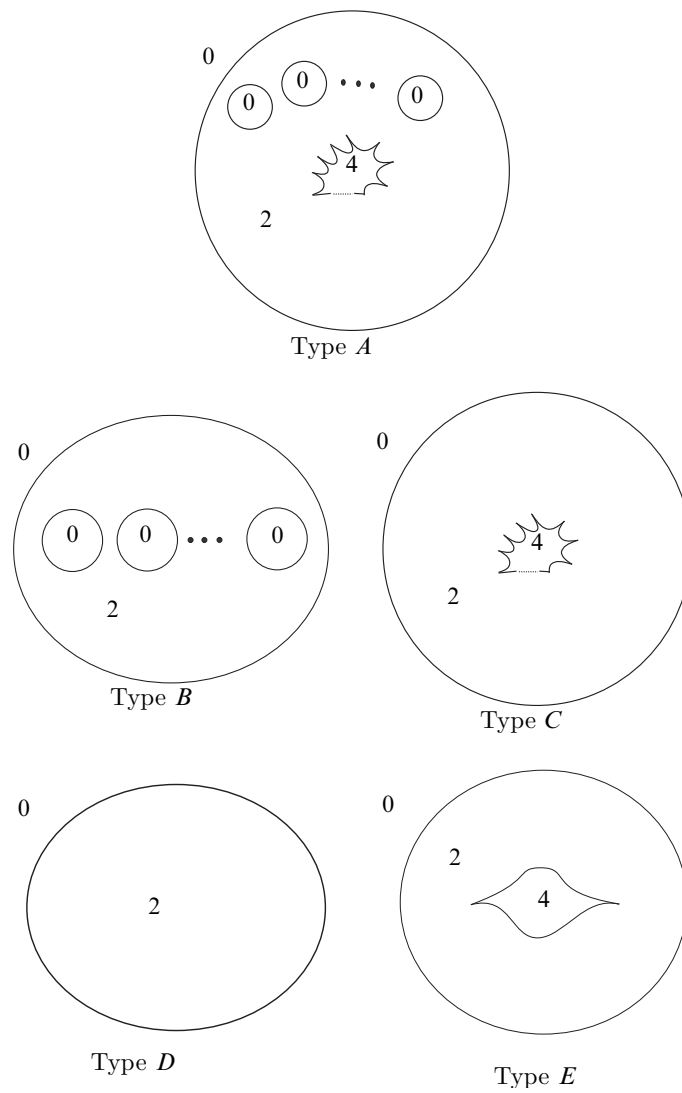

Figure 21: Possible images of the singular set with no fold crossing for  $F \cong S^2$

**Corollary 5.4** *Let  $F \subset \mathbb{R}^4$  be an  $n$ -twist spun 2-bridge knot with  $n \neq \pm 1$ . Then we have  $tw(F) = 8$ .*

**Proof** Since  $F$  is not strongly trivial, by [Theorem 5.3](#) we have  $tw(F) \geq 8$ . On the other hand, since  $F$  has planar projection as in [Figure 15](#), we have  $tw(F) \leq 8$ . This completes the proof.  $\square$

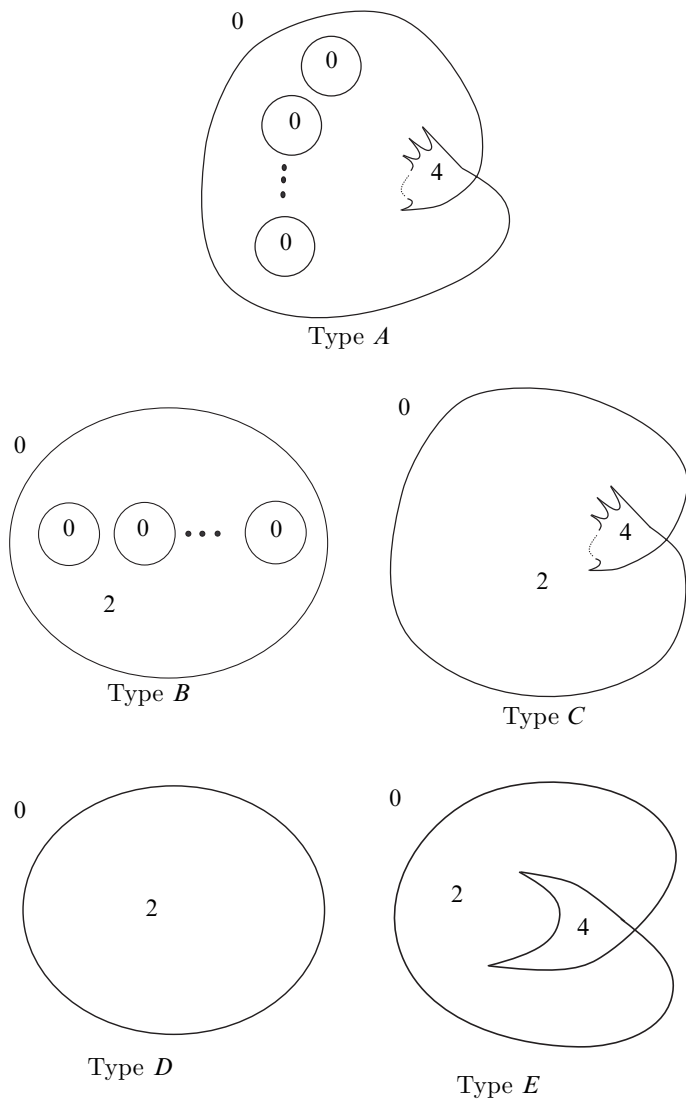

Figure 22: Possible images of the singular set with one fold crossing for  $F \cong S^2$ , part 1

Similarly, for surface knots diffeomorphic to the projective plane, we have the following characterization.

**Theorem 5.5** *Let  $F$  be a surface knot which is diffeomorphic to the projective plane  $\mathbb{R}P^2$ . Then  $tw(F) \leq 6$  if and only if it is trivial.*



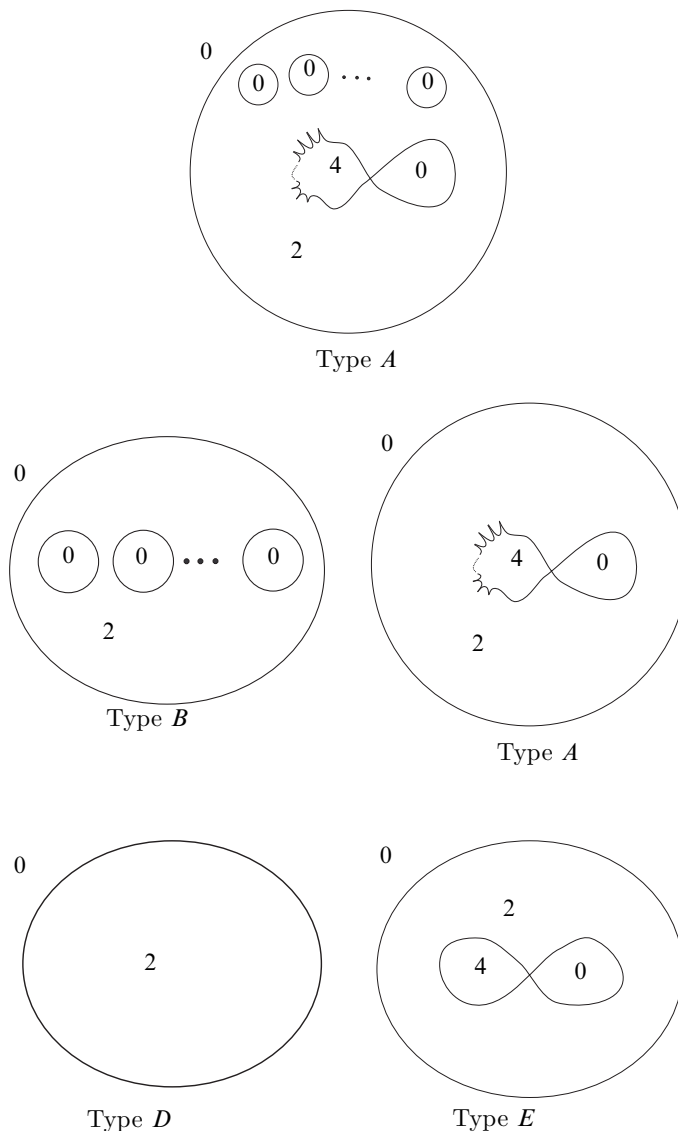

Figure 23: Possible images of the singular set with one fold crossing for  $F \cong S^2$ , part 2

**Proof** If  $tw(F) = 2$ , then by [Theorem 5.1](#),  $F$  is strongly trivial. Furthermore, there does not exist a surface knot  $F$  with  $tw(F) = 4$ , since  $F$  is connected. Therefore, we may assume  $tw(F) = 6$  and there exists an orthogonal projection  $\pi: \mathbb{R}^4 \rightarrow \mathbb{R}^2$  which is generic with respect to  $F$  such that  $tw(F, \pi) = tw(F)$ .

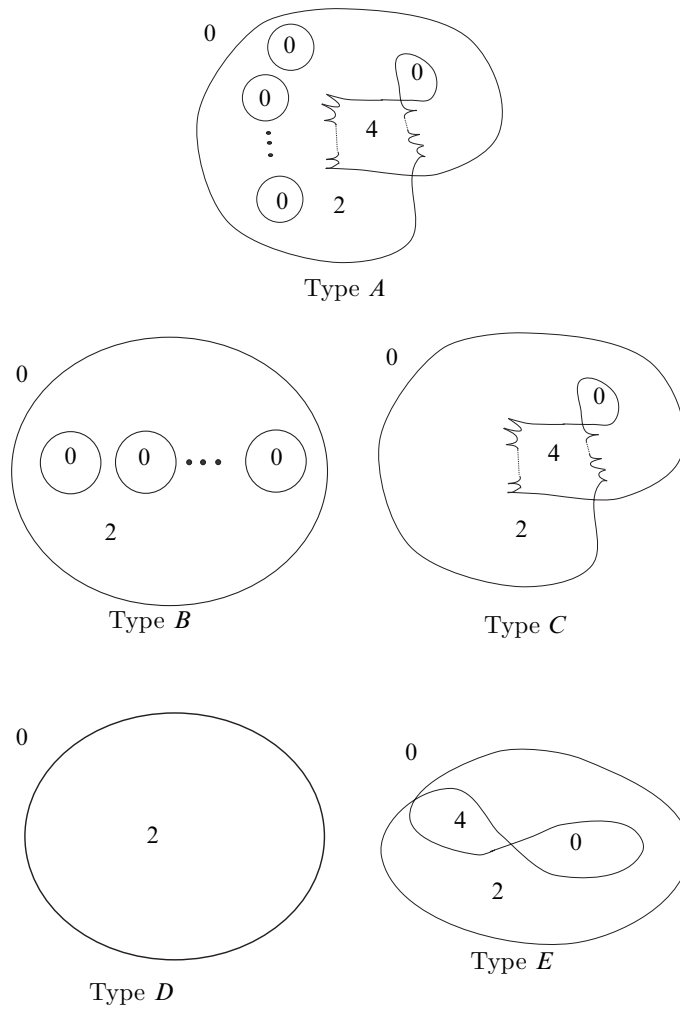

Figure 24: Possible images of the singular set with two fold crossings for  $F \cong S^2$ , part 1

We use the argument of the proof of [Theorem 5.3](#). If  $\pi(S(\pi|_F))$  has no fold crossings, then it is of the form “Type A” as depicted in [Figure 21](#). Since  $F$  is diffeomorphic to the projective plane, by [Lemma 3.1](#) we see that  $F = F_1 \sharp F_2$ , where  $\pi(S(\pi|_{F_1}))$  is of the form “Type D” as depicted in [Figure 21](#) and  $\pi(S(\pi|_{F_2}))$  is of the form “Type A” as depicted in [Figure 27](#). By [Lemma 2.9](#),  $F_1$  is strongly trivial. Since there exists an orthogonal projection  $\pi_1^4: \mathbb{R}^4 \rightarrow \mathbb{R}^1$  which is generic with respect to  $F_2$  such that  $\pi_1^4|_{F_2}$  has exactly three critical points, we see that  $F_2$  is trivial by Bleiler and Scharlemann [\[2\]](#). Therefore,  $F$  is trivial.

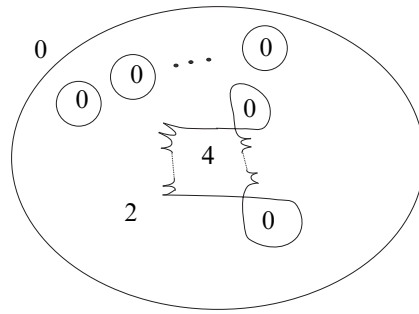

Figure 25: Possible image of the singular set with two fold crossings for  $F \cong S^2$ , part 2

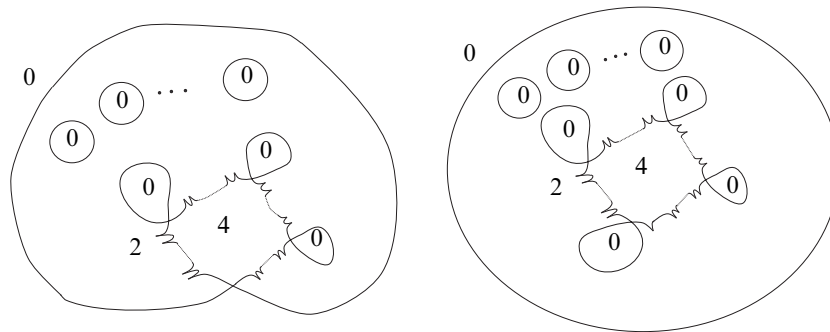

Figure 26: Possible images of the singular set with three or more fold crossings for  $F \cong S^2$

If  $\pi(S(\pi|_F))$  has one fold crossing, then it is of the form “Type A” as depicted in Figure 22 or in Figure 23 up to isotopy of  $\mathbb{R}^2$ . Since  $F$  is diffeomorphic to the projective plane, by Lemma 3.1 we see that  $F = F_1 \# F_2$ , where  $\pi(S(\pi|_{F_1}))$  is of the form “Type D” as depicted in Figure 22 or Figure 23 and  $\pi(S(\pi|_{F_2}))$  is of the form “Type B” or “Type C” as depicted in Figure 27. By Lemma 2.9,  $F_1$  is strongly trivial. Since there exists an orthogonal projection  $\pi_1^4: \mathbb{R}^4 \rightarrow \mathbb{R}^1$  which is generic with respect to  $F_2$  such that  $\pi_1^4|_{F_2}$  has exactly three critical points, we see that  $F_2$  is trivial by [2]. Therefore,  $F$  is trivial.

If  $\pi(S(\pi|_F))$  has two fold crossings, then it is of the form “Type A” as depicted in Figure 24 or as depicted in Figure 25. In the former case, we see that  $F$  is trivial as before (see “Type D” in Figure 27). In the latter case, we see that  $\chi(F) < \chi(\mathbb{R}P^2)$  by Lemma 5.2, which is a contradiction. Thus, this case does not occur.

If  $\pi(S(\pi|_F))$  has three or more fold crossings, then it is of the form as depicted in Figure 26. Then, we see that  $\chi(F) < \chi(\mathbb{R}P^2)$  by Lemma 5.2, so that this case does not occur.

Hence  $F$  is always trivial. This completes the proof.  $\square$

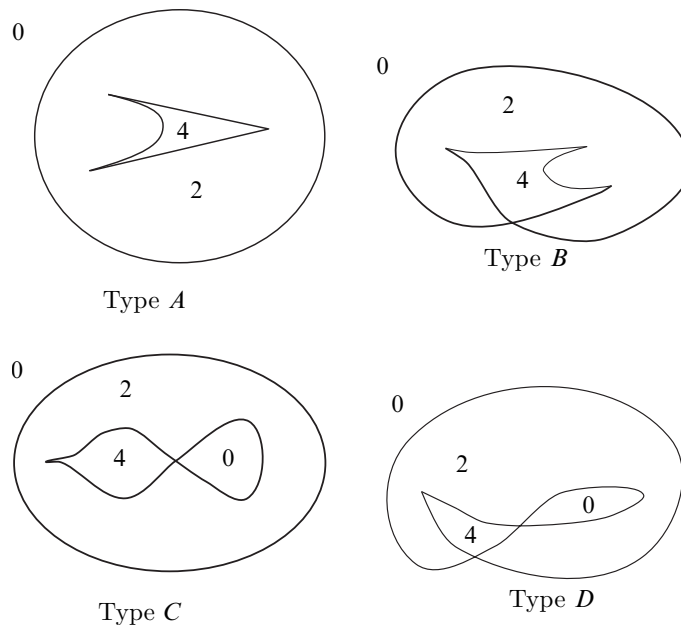

Figure 27: Possible images of the singular set for  $F \cong \mathbb{R}P^2$  with  $tw(F) = 6$

**Remark 5.6** We do not know if a similar characterization theorem holds for surface knots of higher genus. For example, in Figures 28 and 29 we have listed all the possible configurations of the planar image of the singular set for knotted Klein bottles with total width smaller than or equal to six. In general, we have many cusps and cannot apply Lemma 2.9 directly. Furthermore, we have no unknotting theorem as in [2; 17] for embedded Klein bottles as far as the author knows.

## References

- [1] **PM Akhmet'ev**, *Smooth immersions of manifolds of small dimension*, Mat. Sb. 185 (1994) 3–26 [MR1309180](#)

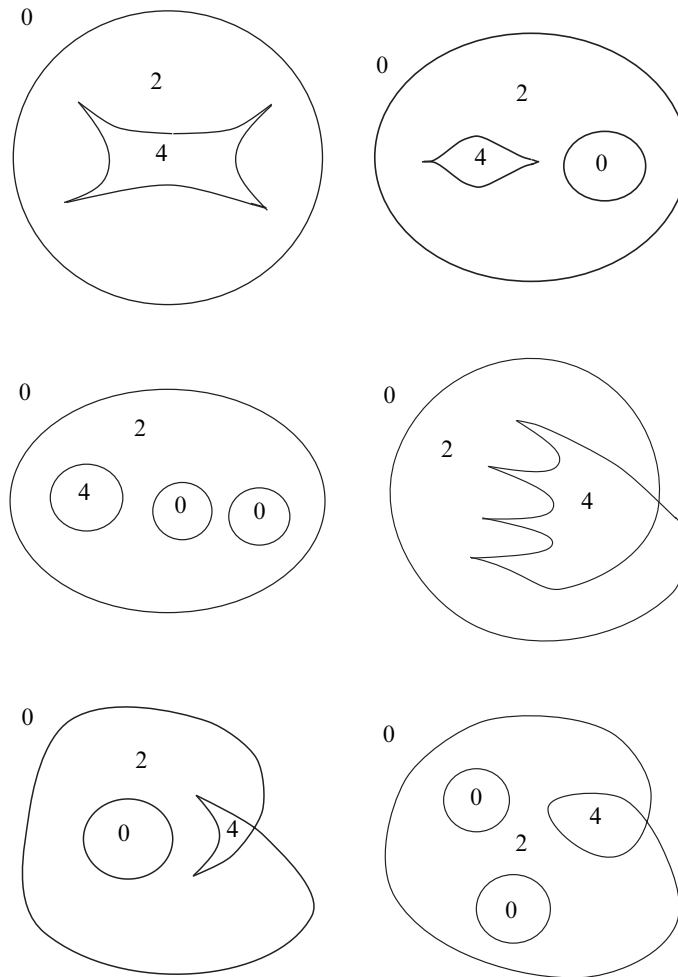

Figure 28: Possible configurations for the Klein bottle case, part 1

- [2] **S Bleiler, M Scharlemann**, *A projective plane in  $\mathbf{R}^4$  with three critical points is standard. Strongly invertible knots have property  $P$* , *Topology* 27 (1988) 519–540 [MR976593](#)
- [3] **V Carrara, JS Carter, M Saito**, *Singularities of the projections of surfaces in 4-space*, *Pacific J. Math.* 199 (2001) 21–40 [MR1847145](#)
- [4] **VL Carrara, MAS Ruas, O Saeki**, *Maps of manifolds into the plane which lift to standard embeddings in codimension two*, *Topology Appl.* 110 (2001) 265–287 [MR1807468](#)

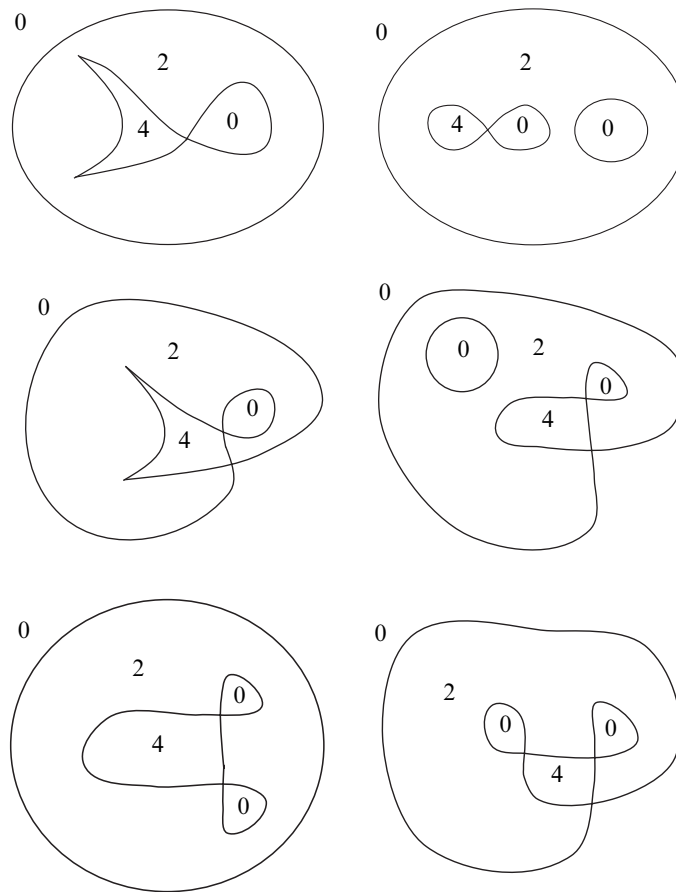

Figure 29: Possible configurations for the Klein bottle case, part 2

- [5] **J S Carter, M Saito**, *Knotted surfaces and their diagrams*, Mathematical Surveys and Monographs 55, American Mathematical Society (1998) [MR1487374](#)
- [6] **T Cochran**, *Ribbon knots in  $S^4$* , J. London Math. Soc. (2) 28 (1983) 563–576 [MR724727](#)
- [7] **T Fukuda**, *Topology of folds, cusps and Morin singularities*, from: “A fête of topology”, Academic Press, Boston (1988) 331–353 [MR928406](#)
- [8] **D Gabai**, *Foliations and the topology of 3-manifolds. III*, J. Differential Geom. 26 (1987) 479–536 [MR910018](#)
- [9] **M Golubitsky, V Guillemin**, *Stable mappings and their singularities*, Graduate Texts in Mathematics 14, Springer, New York (1973) [MR0341518](#)

- [10] **F Hosokawa, A Kawauchi**, *Proposals for unknotted surfaces in four-spaces*, Osaka J. Math. 16 (1979) 233–248 [MR527028](#)
- [11] **S Kamada**, *Surfaces in  $\mathbf{R}^4$  of braid index three are ribbon*, J. Knot Theory Ramifications 1 (1992) 137–160 [MR1164113](#)
- [12] **S Kamada**, *Braid and knot theory in dimension four*, Mathematical Surveys and Monographs 95, American Mathematical Society (2002) [MR1900979](#)
- [13] **A Kawauchi**, *On pseudo-ribbon surface-links*, J. Knot Theory Ramifications 11 (2002) 1043–1062 [MR1941684](#)
- [14] **H I Levine**, *Mappings of manifolds into the plane*, Amer. J. Math. 88 (1966) 357–365 [MR0208609](#)
- [15] **J N Mather**, *Generic projections*, Ann. of Math. (2) 98 (1973) 226–245 [MR0362393](#)
- [16] **O Saeki, Y Takeda**, *Canceling branch points and cusps on projections of knotted surfaces in 4-space*, Proc. Amer. Math. Soc. 132 (2004) 3097–3101 [MR2063132](#)
- [17] **M Scharlemann**, *Smooth spheres in  $\mathbf{R}^4$  with four critical points are standard*, Invent. Math. 79 (1985) 125–141 [MR774532](#)
- [18] **K Tanaka**, *Crossing changes for pseudo-ribbon surface-knots*, Osaka J. Math. 41 (2004) 877–890 [MR2116343](#)
- [19] **K Tanaka**, *The braid index of surface-knots and quandle colorings*, Illinois J. Math. 49 (2005) 517–522 [MR2164349](#)
- [20] **R Thom**, *Les singularités des applications différentiables*, Ann. Inst. Fourier, Grenoble 6 (1955–1956) 43–87 [MR0087149](#)
- [21] **O J Viro**, *Local knotting of sub-manifolds*, Mat. Sb. (N.S.) 90(132) (1973) 173–183, 325 [MR0370606](#) (Russian) English translation: Math. USSR-Sb. 19 (1973) 166–176 (1974)
- [22] **M Yamamoto**, *Lifting a generic map from a surface into the plane to an embedding into 4-space*, preprint (2005)
- [23] **T Yasuda**, *Crossing and base numbers of ribbon 2-knots*, J. Knot Theory Ramifications 10 (2001) 999–1003 [MR1867105](#)
- [24] **E C Zeeman**, *Twisting spun knots*, Trans. Amer. Math. Soc. 115 (1965) 471–495 [MR0195085](#)

Graduate School of Mathematics, Kyushu University  
Hakozaki, Fukuoka 812-8581, Japan

[takeda@math.kyushu-u.ac.jp](mailto:takeda@math.kyushu-u.ac.jp)

Received: 7 February 2006      Revised: 10 August 2006