

# Instanton Floer homology and the Alexander polynomial

PETER KRONHEIMER

TOM MROWKA

The instanton Floer homology of a knot in the three-sphere is a vector space with a canonical mod 2 grading. It carries a distinguished endomorphism of even degree, arising from the 2–dimensional homology class represented by a Seifert surface. The Floer homology decomposes as a direct sum of the generalized eigenspaces of this endomorphism. We show that the Euler characteristics of these generalized eigenspaces are the coefficients of the Alexander polynomial of the knot. Among other applications, we deduce that instanton homology detects fibered knots.

57R58; 57M25

## 1 Introduction

For a knot  $K \subset S^3$ , the authors defined in [7] a Floer homology group  $KHI(K)$ , by a slight variant of a construction that appeared first in Floer’s paper [3]. In brief, one takes the knot complement  $S^3 \setminus N^\circ(K)$  and forms from it a closed 3–manifold  $Z(K)$  by attaching to  $\partial N(K)$  the manifold  $F \times S^1$ , where  $F$  is a genus–1 surface with one boundary component. The attaching is done in such a way that  $\{\text{point}\} \times S^1$  is glued to the meridian of  $K$  and  $\partial F \times \{\text{point}\}$  is glued to the longitude. The vector space  $KHI(K)$  is then defined by applying Floer’s instanton homology to the closed 3–manifold  $Z(K)$ . We will recall the details in Section 2. If  $\Sigma$  is a Seifert surface for  $K$ , then there is a corresponding closed surface  $\bar{\Sigma}$  in  $Z(K)$ , formed as the union of  $\Sigma$  and one copy of  $F$ . The homology class  $\bar{\sigma} = [\bar{\Sigma}]$  in  $H_2(Z(K))$  determines an endomorphism  $\mu(\bar{\sigma})$  on the instanton homology of  $Z(K)$ , and hence also an endomorphism of  $KHI(K)$ . As was shown in [7], and as we recall below, the generalized eigenspaces of  $\mu(\bar{\sigma})$  give a direct sum decomposition,

$$(1) \quad KHI(K) = \bigoplus_{j=-g}^g KHI(K, j).$$

Here  $g$  is the genus of the Seifert surface. In this paper, we will define a canonical  $\mathbb{Z}/2$  grading on  $KHI(K)$ , and hence on each  $KHI(K, j)$ , so that we may write

$$KHI(K, j) = KHI_0(K, j) \oplus KHI_1(K, j).$$

This allows us to define the Euler characteristic  $\chi(KHI(K, j))$  as the difference of the ranks of the even and odd parts. The main result of this paper is the following theorem.

**Theorem 1.1** *For any knot in  $S^3$ , the Euler characteristics  $\chi(KHI(K, j))$  of the summands  $KHI(K, j)$  are minus the coefficients of the symmetrized Alexander polynomial  $\Delta_K(t)$ , with Conway’s normalization. That is,*

$$\Delta_K(t) = - \sum_j \chi(KHI(K, j))t^j.$$

The Floer homology group  $KHI(K)$  is supposed to be an “instanton” counterpart to the Heegaard knot homology of Ozsváth and Szabó [12] and Rasmussen [13]. It is known that the Euler characteristic of Heegaard knot homology gives the Alexander polynomial; so the above theorem can be taken as further evidence that the two theories are indeed closely related.

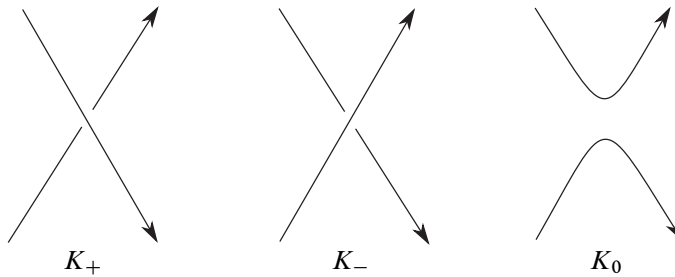

Figure 1: Knots  $K_+$ ,  $K_-$  and  $K_0$  differing at a single crossing

The proof of the theorem rests on Conway’s skein relation for the Alexander polynomial. To exploit the skein relation in this way, we first extend the definition of  $KHI(K)$  to links. Then, given three oriented knots or links  $K_+$ ,  $K_-$  and  $K_0$  related by the skein moves (see Figure 1), we establish a long exact sequence relating the instanton knot (or link) homologies of  $K_+$ ,  $K_-$  and  $K_0$ . More precisely, if for example  $K_+$  and  $K_-$  are knots and  $K_0$  is a 2–component link, then we will show that there is along exact sequence

$$\dots \rightarrow KHI(K_+) \rightarrow KHI(K_-) \rightarrow KHI(K_0) \rightarrow \dots .$$

(This situation is a little different when  $K_+$  and  $K_-$  are 2–component links and  $K_0$  is a knot: see Theorem 3.1.)

Skein exact sequences of this sort for  $KHI(K)$  are not new. The definition of  $KHI(K)$  appears almost verbatim in Floer’s paper [3], along with outline proofs of just such a skein sequence. See in particular part (2’) of Theorem 5 in [3], which corresponds to Theorem 3.1 in this paper. The material of Floer’s paper [3] is also presented by Braam

and Donaldson [1]. The proof of the skein exact sequence which we shall describe is essentially Floer's argument, as amplified in [1], though we shall present it in the context of sutured manifolds. The new ingredient however is the decomposition (1) of the instanton Floer homology, without which one cannot arrive at the Alexander polynomial.

The structure of the remainder of this paper is as follows. In Section 2, we recall the construction of instanton knot homology, as well as instanton homology for sutured manifolds, following [7]. We take the opportunity here to extend and slightly generalize our earlier results concerning these constructions. Section 3 presents the proof of the main theorem. Some applications are discussed in Section 4. The relationship between  $\Delta_K(t)$  and the instanton homology of  $K$  was conjectured in [7], and the result provides the missing ingredient to show that the  $KHI$  detects fibered knots. Theorem 1.1 also provides a lower bound for the rank of the instanton homology group:

**Corollary 1.2** *If the Alexander polynomial of  $K$  is  $\sum_{-d}^d a_j t^j$ , then the rank of  $KHI(K)$  is not less than  $\sum_{-d}^d |a_j|$ .  $\square$*

The corollary can be used to draw conclusions about the existence of certain representations of the knot group in  $SU(2)$ .

**Acknowledgments** As this paper was being completed, the authors learned that essentially the same result has been obtained simultaneously by Yuhan Lim [9]. The authors are grateful to the referee for pointing out the errors in an earlier version of this paper, particularly concerning the mod 2 gradings.

The work of the first author was supported by the National Science Foundation through NSF grant number DMS-0405271. The work of the second author was supported by NSF grants DMS-0206485, DMS-0244663 and DMS-0805841.

## 2 Background

### 2.1 Instanton Floer homology

Let  $Y$  be a closed, connected, oriented 3-manifold, and let  $w \rightarrow Y$  be a hermitian line bundle with the property that the pairing of  $c_1(w)$  with some class in  $H_2(Y)$  is odd. If  $E \rightarrow Y$  is a  $U(2)$  bundle with  $\Lambda^2 E \cong w$ , we write  $\mathcal{B}(Y)_w$  for the space of  $PU(2)$  connections in the adjoint bundle  $\text{ad}(E)$ , modulo the action of the gauge group consisting of automorphisms of  $E$  with determinant 1. The instanton Floer homology

group  $I_*(Y)_w$  is the Floer homology arising from the Chern–Simons functional on  $\mathcal{B}(Y)_w$ . It has a relative grading by  $\mathbb{Z}/8$ . Our notation for this Floer group follows [7]; an exposition of its construction is in [2]. We will always use complex coefficients, so  $I_*(Y)_w$  is a complex vector space.

If  $\sigma$  is a 2–dimensional integral homology class in  $Y$ , then there is a corresponding operator  $\mu(\sigma)$  on  $I_*(Y)_w$  of degree  $-2$ . If  $y \in Y$  is a point representing the generator of  $H_0(Y)$ , then there is also a degree–4 operator  $\mu(y)$ . The operators  $\mu(\sigma)$ , for  $\sigma \in H_2(Y)$ , commute with each other and with  $\mu(y)$ . As shown in [7] based on the calculations of [10], the simultaneous eigenvalues of the commuting pair of operators  $(\mu(y), \mu(\sigma))$  all have the form

$$(2) \quad (2, 2k) \quad \text{or} \quad (-2, 2k\sqrt{-1}),$$

for even integers  $2k$  in the range

$$|2k| \leq |\sigma|.$$

Here  $|\sigma|$  denotes the Thurston norm of  $\sigma$ , the minimum value of  $-\chi(\Sigma)$  over all aspherical embedded surfaces  $\Sigma$  with  $[\Sigma] = \sigma$ .

## 2.2 Instanton homology for sutured manifolds

We recall the definition of the instanton Floer homology for a balanced sutured manifold, as introduced in [7] with motivation from the Heegaard counterpart defined in [4]. The reader is referred to [7; 4] for background and details.

Let  $(M, \gamma)$  be a balanced sutured manifold. Its oriented boundary is a union

$$\partial M = R_+(\gamma) \cup A(\gamma) \cup (-R_-(\gamma))$$

where  $A(\gamma)$  is a union of annuli, neighborhoods of the sutures  $s(\gamma)$ . To define the instanton homology group  $SHI(M, \gamma)$  we proceed as follows. Let  $([-1, 1] \times T, \delta)$  be a product sutured manifold, with  $T$  a connected, oriented surface with boundary. The annuli  $A(\delta)$  are the annuli  $[-1, 1] \times \partial T$ , and we suppose these are in one-to-one correspondence with the annuli  $A(\gamma)$ . We attach this product piece to  $(M, \gamma)$  along the annuli to obtain a manifold

$$(3) \quad \bar{M} = M \cup ([-1, 1] \times T).$$

We write

$$(4) \quad \partial \bar{M} = \bar{R}_+ \cup (-\bar{R}_-).$$

We can regard  $\bar{M}$  as a sutured manifold (not balanced, because it has no sutures). The surface  $\bar{R}_+$  and  $\bar{R}_-$  are both connected and are diffeomorphic. We choose an orientation-preserving diffeomorphism

$$h: \bar{R}_+ \rightarrow \bar{R}_-$$

and then define  $Z = Z(M, \gamma)$  as the quotient space

$$Z = \bar{M} / \sim,$$

where  $\sim$  is the identification defined by  $h$ . The two surfaces  $\bar{R}_\pm$  give a single closed surface

$$\bar{R} \subset Z.$$

We need to impose a side condition on the choice of  $T$  and  $h$  in order to proceed. We require that there is a closed curve  $c$  in  $T$  such that  $\{1\} \times c$  and  $\{-1\} \times c$  become nonseparating curves in  $\bar{R}_+$  and  $\bar{R}_-$  respectively; and we require further that  $h$  is chosen so as to carry  $\{1\} \times c$  to  $\{-1\} \times c$  by the identity map on  $c$ .

**Definition 2.1** We say that  $(Z, \bar{R})$  is an admissible closure of  $(M, \gamma)$  if it arises in this way, from some choice of  $T$  and  $h$ , satisfying the above conditions.

**Remark** In [7, Definition 4.2], there was an additional requirement that  $\bar{R}_\pm$  should have genus 2 or more. This was needed only in the context there of Seiberg–Witten Floer homology, as explained in Section 7.6 of [7]. Furthermore, the notion of closure in [7] did not require that  $h$  carry  $\{1\} \times c$  to  $\{-1\} \times c$ , hence the qualification “admissible” in the present paper.

In an admissible closure, the curve  $c$  gives rise to a torus  $S^1 \times c$  in  $Z$  which meets  $\bar{R}$  transversely in a circle. Pick a point  $x$  on  $c$ . The closed curve  $S^1 \times \{x\}$  lies on the torus  $S^1 \times c$  and meets  $\bar{R}$  in a single point. We write

$$w \rightarrow Z$$

for a hermitian line bundle on  $Z$  whose first Chern class is dual to  $S^1 \times \{x\}$ . Since  $c_1(w)$  has odd evaluation on the closed surface  $\bar{R}$ , the instanton homology group  $I_*(Z)_w$  is well-defined. As in [7], we write

$$I_*(Z|\bar{R})_w \subset I_*(Z)_w$$

for the simultaneous generalized eigenspace of the pair of operators

$$(\mu(y), \mu(\bar{R}))$$

belonging to the eigenvalues  $(2, 2g - 2)$ , where  $g$  is the genus of  $\bar{R}$ . (See (2).)

**Definition 2.2** For a balanced sutured manifold  $(M, \gamma)$ , the instanton Floer homology group  $SHI(M, \gamma)$  is defined to be  $I_*(Z|\bar{R})_w$ , where  $(Z, \bar{R})$  is any admissible closure of  $(M, \gamma)$ .

It was shown in [7] that  $SHI(M, \gamma)$  is well-defined, in the sense that any two choices of  $T$  or  $h$  will lead to isomorphic versions of  $SHI(M, \gamma)$ .

### 2.3 Relaxing the rules on $T$

As stated, the definition of  $SHI(M, \gamma)$  requires that we form a closure  $(Z, \bar{R})$  using a *connected* auxiliary surface  $T$ . We can relax this condition on  $T$ , with a little care, and the extra freedom gained will be convenient in later arguments.

So let  $T$  be a possibly disconnected, oriented surface with boundary. The number of boundary components of  $T$  needs to be equal to the number of sutures in  $(M, \gamma)$ . We then need to choose an orientation-reversing diffeomorphism between  $\partial T$  and  $\partial R_+(\gamma)$ , so as to be able to form a manifold  $\bar{M}$  as in (3), gluing  $[-1, 1] \times \partial T$  to the annuli  $A(\gamma)$ . We continue to write  $\bar{R}_+$ ,  $\bar{R}_-$  for the “top” and “bottom” parts of the boundary of  $\partial \bar{M}$ , as at (4). Neither of these need be connected, although they have the same Euler number. We shall impose the following conditions.

- (1) On each connected component  $T_i$  of  $T$ , there is an oriented simple closed curve  $c_i$  such that the corresponding curves  $\{1\} \times c_i$  and  $\{-1\} \times c_i$  are both nonseparating on  $\bar{R}_+$  and  $\bar{R}_-$  respectively.
- (2) There exists a diffeomorphism  $h: \bar{R}_+ \rightarrow \bar{R}_-$  which carries  $\{1\} \times c_i$  to  $\{-1\} \times c_i$  for all  $i$ , as oriented curves.
- (3) There is a 1-cycle  $c'$  on  $\bar{R}_+$  which intersects each curve  $\{1\} \times c_i$  once.

We then choose any  $h$  satisfying (2) and use  $h$  to identify the top and bottom, so forming a closed pair  $(Z, \bar{R})$  as before. The surface  $\bar{R}$  may have more than one component (but no more than the number of components of  $T$ ). No component of  $\bar{R}$  is a sphere, because each component contains a nonseparating curve. We may regard  $T$  as a codimension-zero submanifold of  $\bar{R}$  via the inclusion of  $\{1\} \times T$  in  $\bar{R}_+$ .

For each component  $\bar{R}_k$  of  $\bar{R}$ , we now choose one corresponding component  $T_{i_k}$  of  $T \cap \bar{R}_k$ . We take  $w \rightarrow Z$  to be the complex line bundle with  $c_1(w)$  dual to the sum of the circles  $S^1 \times \{x_k\} \subset S^1 \times c_{i_k}$ . Thus  $c_1(w)$  evaluates to 1 on each component  $\bar{R}_k \subset \bar{R}$ . We may then consider the instanton Floer homology group  $I_*(Z|\bar{R})_w$ .

**Lemma 2.3** *Subject to the conditions we have imposed, the Floer homology group  $I_*(Z|\bar{R})_w$  is independent of the choices made. In particular,  $I_*(Z|\bar{R})_w$  is isomorphic to  $SHI(M, \gamma)$ .*

**Proof** By a sequence of applications of the excision property of Floer homology [3; 7], we shall establish that  $I_*(Z|\bar{R})_w$  is isomorphic to  $I_*(Z'|\bar{R}')_{w'}$ , where the latter arises from the same construction but with a *connected* surface  $T'$ . Thus  $I_*(Z'|\bar{R}')_{w'}$  is isomorphic to  $SHI(M, \gamma)$  by definition: its independence of the choices made is proved in [7].

We will show how to reduce the number of components of  $T$  by one. Following the argument of [7, Section 7.4], we have an isomorphism

$$(5) \quad I_*(Z|\bar{R})_w \cong I_*(Z|\bar{R})_u,$$

where  $u \rightarrow Z$  is the complex line bundle whose first Chern class is dual to the cycle  $c' \subset Z$ . We shall suppose in the first instance that at least one of  $c_i$  or  $c_j$  is nonseparating in the corresponding component  $T_i$  or  $T_j$ . Since  $c_1(u)$  is odd on the 2-tori  $S^1 \times c_i$  and  $S^1 \times c_j$ , we can apply Floer's excision theorem (see also [7, Theorem 7.7]): we cut  $Z$  open along these two 2-tori and glue back to obtain a new pair  $(Z'|\bar{R}')$ , carrying a line bundle  $u'$ , and we have

$$I_*(Z|\bar{R})_u \cong I_*(Z'|\bar{R}')_{u'}.$$

Reversing the construction that led to the isomorphism (5), we next have

$$I_*(Z'|\bar{R}')_{u'} \cong I_*(Z'|\bar{R}')_{w'},$$

where the line bundle  $w'$  is dual to a collection of circles  $S^1 \times \{x'_k\}$ , one for each component of  $\bar{R}'$ . The pair  $(Z', \bar{R}')$  is obtained from the sutured manifold  $(M, \gamma)$  by the same construction that led to  $(Z, R)$ , but with a surface  $T'$  having one fewer components: the components  $T_i$  and  $T_j$  have been joined into one component by cutting open along the circles  $c_i$  and  $c_j$  and regluing.

If both  $c_i$  and  $c_j$  are separating in  $T_i$  and  $T_j$  respectively, then the above argument fails, because  $T'$  will have the same number of components as  $T$ . In this case, we can alter  $T_i$  and  $c_i$  to make a new  $T'_i$  and  $c'_i$ , with  $c'_i$  nonseparating in  $T'_i$ . For example, we may replace  $Z$  by the disjoint union  $Z \sqcup Z_*$ , where  $Z_*$  is a product  $S^1 \times T_*$ , with  $T_*$  of genus 2. In the same manner as above, we can cut  $Z$  along  $S^1 \times c_i$  and cut  $Z_*$  along  $S^1 \times c_*$ , and then reglue, interchanging the boundary components. The effect of this is to replace  $T_i$  by a surface  $T'_i$  of genus one larger. We can take  $c'_i$  to be a nonseparating curve on  $T_* \setminus c_*$ . □

## 2.4 Instanton homology for knots and links

Consider a link  $K$  in a closed oriented 3-manifold  $Y$ . Following Juhász [4], we can associate to  $(Y, K)$  a sutured manifold  $(M, \gamma)$  by taking  $M$  to be the link complement

and taking the sutures  $s(\gamma)$  to consist of two oppositely-oriented meridional curves on each of the tori in  $\partial M$ . As in [7], where the case of knots was discussed, we take Juhász's prescription as a definition for the instanton knot (or link) homology of the pair  $(Y, K)$ :

**Definition 2.4** (cf [4]) We define the instanton homology of the link  $K \subset Y$  to be the instanton Floer homology of the sutured manifold  $(M, \gamma)$  obtained from the link complement as above. Thus,

$$KHI(Y, K) = SHI(M, \gamma).$$

Although we are free to choose any admissible closure  $Z$  in constructing  $SHI(M, \gamma)$ , we can exploit the fact that we are dealing with a link complement to narrow our choices. Let  $r$  be the number of components of the link  $K$ . Orient  $K$  and choose a longitudinal oriented curve  $l_i \subset \partial M$  on the peripheral torus of each component  $K_i \subset K$ . Let  $F_r$  be a genus-1 surface with  $r$  boundary components,  $\delta_1, \dots, \delta_r$ . Form a closed manifold  $Z$  by attaching  $F_r \times S^1$  to  $M$  along their boundaries:

$$(6) \quad Z = (Y \setminus N^\circ(K)) \cup (F_r \times S^1).$$

The attaching is done so that the curve  $p_i \times S^1$  for  $p_i \in \delta_i$  is attached to the meridian of  $K_i$  and  $\delta_i \times \{q\}$  is attached to the chosen longitude  $l_i$ . We can view  $Z$  as a closure of  $(M, \gamma)$  in which the auxiliary surface  $T$  consists of  $r$  annuli,

$$T = T_1 \cup \dots \cup T_r.$$

The two sutures of the product sutured manifold  $[-1, 1] \times T_i$  are attached to meridional sutures on the components of  $\partial M$  corresponding to  $K_i$  and  $K_{i-1}$  in some cyclic ordering of the components. Viewed this way, the corresponding surface  $\bar{R} \subset Z$  is the torus

$$\bar{R} = \nu \times S^1$$

where  $\nu \subset F_r$  is a closed curve representing a generator of the homology of the closed genus-1 surface obtained by adding disks to  $F_r$ . Because  $\bar{R}$  is a torus, the group  $I_*(Z|\bar{R})_w$  can be more simply described as the generalized eigenspace of  $\mu(\gamma)$  belonging to the eigenvalue 2, for which we temporarily introduce the notation  $I_*(Z)_{w,+2}$ . Thus we can write

$$KHI(Y, K) = I_*(Z)_{w,+2}.$$

An important special case for us is when  $K \subset Y$  is null-homologous in  $Y$  with its given orientation. In this case, we may choose a Seifert surface  $\Sigma$ , which we regard as a properly embedded oriented surface in  $M$  with oriented boundary a union of



longitudinal curves, one for each component of  $K$ . When a Seifert surface is given, we have a *uniquely preferred* closure  $Z$ , obtained as above but using the longitudes provided by  $\partial\Sigma$ . Let us fix a Seifert surface  $\Sigma$  and write  $\sigma$  for its homology class in  $H_2(M, \partial M)$ . The preferred closure of the sutured link complement is entirely determined by  $\sigma$ .

### 2.5 The decomposition into generalized eigenspaces

We continue to suppose that  $\Sigma$  is a Seifert surface for the null-homologous oriented knot  $K \subset Y$ . We write  $(M, \gamma)$  for the sutured link complement and  $Z$  for the preferred closure.

The homology class  $\sigma = [\Sigma]$  in  $H_2(M, \partial M)$  extends to a class  $\bar{\sigma} = [\bar{\Sigma}]$  in  $H_2(Z)$ : the surface  $\bar{\Sigma}$  is formed from the Seifert surface  $\Sigma$  and  $F_r$ ,

$$\bar{\Sigma} = \Sigma \cup F_r.$$

The homology class  $\bar{\sigma}$  determines an endomorphism

$$\mu(\bar{\sigma}): I_*(Z)_{w,+2} \rightarrow I_*(Z)_{w,+2}.$$

This endomorphism is traceless, a consequence of the relative  $\mathbb{Z}/8$  grading: there is an endomorphism  $\epsilon$  of  $I_*(Z)_w$  given by multiplication by  $(\sqrt{-1})^s$  on the part of relative grading  $s$ , and this  $\epsilon$  commutes with  $\mu(y)$  and anticommutes with  $\mu(\bar{\sigma})$ . We write this traceless endomorphism as

$$(7) \quad \mu^o(\sigma) \in \mathfrak{sl}(KHI(Y, K)).$$

Our notation hides the fact that the construction depends (a priori) on the existence of the preferred closure  $Z$ , so that  $KHI(Y, K)$  can be canonically identified with  $I_*(Z)_{w,+2}$ .

It now follows from [7, Proposition 7.5] that the eigenvalues of  $\mu^o(\sigma)$  are even integers  $2j$  in the range  $-2\bar{g} + 2 \leq 2j \leq 2\bar{g} - 2$ , where  $\bar{g} = g(\Sigma) + r$  is the genus of  $\bar{\Sigma}$ . Thus:

**Definition 2.5** For a null-homologous oriented link  $K \subset Y$  with a chosen Seifert surface  $\Sigma$ , we write

$$KHI(Y, K, [\Sigma], j) \subset KHI(Y, K)$$

for the generalized eigenspace of  $\mu^o([\Sigma])$  belonging to the eigenvalue  $2j$ , so that

$$KHI(Y, K) = \bigoplus_{j=-g(\Sigma)+1-r}^{g(\Sigma)-1+r} KHI(Y, K, [\Sigma], j),$$

where  $r$  is the number of components of  $K$ . If  $Y$  is a homology sphere, we may omit  $[\Sigma]$  from the notation; and if  $Y$  is  $S^3$  then we simply write  $KHI(K, j)$ .

**Remark** The authors believe that, for a general sutured manifold  $(M, \gamma)$ , one can define a unique linear map

$$\mu^o: H_2(M, \partial M) \rightarrow \mathfrak{sl}(SHI(M, \gamma))$$

characterized by the property that for any admissible closure  $(Z, \bar{R})$  and any  $\bar{\sigma}$  in  $H_2(Z)$  extending  $\sigma \in H_2(M, \partial M)$  we have

$$\mu^o(\sigma) = \text{traceless part of } \mu(\bar{\sigma}),$$

under a suitable identification of  $I_*(Z|\bar{R})_w$  with  $SHI(M, \gamma)$ . The authors will return to this question in a future paper. For now, we are exploiting the existence of a preferred closure  $Z$  so as to side-step the issue of whether  $\mu^o$  would be well-defined, independent of the choices made.

## 2.6 The mod 2 grading

If  $Y$  is a closed 3-manifold, then the instanton homology group  $I_*(Y)_w$  has a canonical decomposition into parts of even and odd grading mod 2. For the purposes of this paper, we normalize our conventions so that the two generators of  $I_*(T^3)_w = \mathbb{C}^2$  are in *odd* degree. As in [8, Section 25.4], the canonical mod 2 grading is then essentially determined by the property that, for a cobordism  $W$  from a manifold  $Y_-$  to  $Y_+$ , the induced map on Floer homology has even or odd grading according to the parity of the integer

$$(8) \quad \iota(W) = \frac{1}{2}(\chi(W) + \sigma(W) + b_1(Y_+) - b_0(Y_+) - b_1(Y_-) + b_0(Y_-)).$$

(In the case of connected manifolds  $Y_+$  and  $Y_-$ , this formula reduces to the one that appears in [8] for the monopole case. There is more than one way to extend the formula to the case of disconnected manifolds, and we have simply chosen one.) By declaring that the generators for  $T^3$  are in odd degree, we ensure that the canonical mod 2 gradings behave as expected for disjoint unions of the 3-manifolds. Thus, if  $Y_1$  and  $Y_2$  are the connected components of a 3-manifold  $Y$  and  $\alpha_1 \otimes \alpha_2$  is a class on  $Y$  obtained from  $\alpha_i$  on  $Y_i$ , then  $\text{gr}(\alpha_1 \otimes \alpha_2)$  is  $\text{gr}(\alpha_1) + \text{gr}(\alpha_2)$  in  $\mathbb{Z}/2$  as expected.

Since the Floer homology  $SHI(M, \gamma)$  of a sutured manifold  $(M, \gamma)$  is defined in terms of  $I_*(Z)_w$  for an admissible closure  $Z$ , it is tempting to try to define a canonical mod 2 grading on  $SHI(M, \gamma)$  by carrying over the canonical mod 2 grading from  $Z$ . This does not work, however, because the result will depend on the choice of closure.

This is illustrated by the fact that the mapping torus of a Dehn twist on  $T^2$  may have Floer homology in *even* degree in the canonical mod 2 grading (depending on the sign of the Dehn twist), despite the fact that both  $T^3$  and this mapping torus can be viewed as closures of the same sutured manifold.

We conclude from this that, without auxiliary choices, there is no *canonical* mod 2 grading on  $SHI(M, \gamma)$  in general: only a relative grading. Nevertheless, in the special case of an oriented null-homologous knot or link  $K$  in a closed 3-manifold  $Y$ , we *can* fix a convention that gives an absolute mod 2 grading, once a Seifert surface  $\Sigma$  for  $K$  is given. We simply take the preferred closure  $Z$  described above in Section 2.4, using  $\partial\Sigma$  again to define the longitudes, so that  $KHI(Y, K)$  is identified with  $I_*(Z)_{w,+2}$ , and we use the canonical mod 2 grading from the latter.

With this convention, the unknot  $U$  has  $KHI(U)$  of rank 1, with a single generator in odd grading mod 2.

### 3 The skein sequence

#### 3.1 The long exact sequence

Let  $Y$  be any closed, oriented 3-manifold, and let  $K_+$ ,  $K_-$  and  $K_0$  be any three oriented knots or links in  $Y$  which are related by the standard skein moves: that is, all three links coincide outside a ball  $B$  in  $Y$ , while inside the ball they are as shown in Figure 1. There are two cases which occur here: the two strands of  $K_+$  in  $B$  may belong to the same component of the link, or to different components. In the first case  $K_0$  has one more component than  $K_+$  or  $K_-$ , while in the second case it has one fewer.

**Theorem 3.1** (cf [3, Theorem 5]) *Let  $K_+$ ,  $K_-$  and  $K_0$  be oriented links in  $Y$  as above. Then, in the case that  $K_0$  has one more component than  $K_+$  and  $K_-$ , there is a long exact sequence relating the instanton homology groups of the three links:*

$$(9) \quad \dots \rightarrow KHI(Y, K_+) \rightarrow KHI(Y, K_-) \rightarrow KHI(Y, K_0) \rightarrow \dots .$$

*In the case that  $K_0$  has fewer components than  $K_+$  and  $K_-$ , there is a long exact sequence*

$$(10) \quad \dots \rightarrow KHI(Y, K_+) \rightarrow KHI(Y, K_-) \rightarrow KHI(Y, K_0) \otimes V^{\otimes 2} \rightarrow \dots$$

*where  $V$  a 2-dimensional vector space arising as the instanton Floer homology of the sutured manifold  $(M, \gamma)$ , with  $M$  the solid torus  $S^1 \times D^2$  carrying four parallel sutures  $S^1 \times \{p_i\}$  for four points  $p_i$  on  $\partial D^2$  carrying alternating orientations.*

**Proof** Let  $\lambda$  be a standard circle in the complement of  $K_+$  which encircles the two strands of  $K_+$  with total linking number zero, as shown in Figure 2. Let  $Y_-$  and  $Y_0$

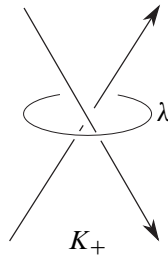

Figure 2: The knot  $K_+$ , with a standard circle  $\lambda$  around a crossing, with linking number zero

be the 3-manifolds obtained from  $Y$  by  $-1$ -surgery and  $0$ -surgery on  $\lambda$  respectively. Since  $\lambda$  is disjoint from  $K_+$ , a copy of  $K_+$  lies in each, and we have new pairs  $(Y_{-1}, K_+)$  and  $(Y_0, K_+)$ . The pair  $(Y_{-1}, K_+)$  can be identified with  $(Y, K_-)$ .

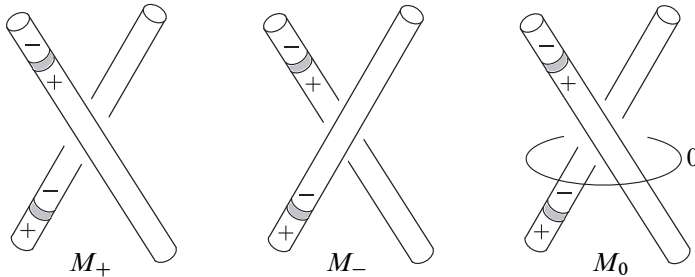

Figure 3: Sutured manifolds obtained from the knot complement, related by a surgery exact triangle

Let  $(M_+, \gamma_+)$ ,  $(M_-, \gamma_-)$  and  $(M_0, \gamma_0)$  be the sutured manifolds associated to the links  $(Y, K_+)$ ,  $(Y, K_-)$  and  $(Y_0, K_0)$  respectively: that is,  $M_+$ ,  $M_-$  and  $M_0$  are the link complements of  $K_+ \subset Y$ ,  $K_- \subset Y$  and  $K_0 \subset Y_0$  respectively, and there are two sutures on each boundary component. (See Figure 3.) The sutured manifolds  $(M_-, \gamma_-)$  and  $(M_0, \gamma_0)$  are obtained from  $(M_+, \gamma_+)$  by  $-1$ -surgery and  $0$ -surgery respectively on the circle  $\lambda \subset M_+$ . If  $(Z, \bar{R})$  is any admissible closure of  $(M_+, \gamma_+)$  then surgery on  $\lambda \subset Z$  yields admissible closures for the other two sutured manifolds. From Floer's surgery exact triangle [1], it follows that there is a long exact sequence

$$(11) \quad \cdots \rightarrow SHI(M_+, \gamma_+) \rightarrow SHI(M_-, \gamma_-) \rightarrow SHI(M_0, \gamma_0) \rightarrow \cdots$$

in which the maps are induced by surgery cobordisms between admissible closures of the sutured manifolds.

By definition, we have

$$\begin{aligned} SHI(M_+, \gamma_+) &= KHI(Y, K_+) \\ SHI(M_-, \gamma_-) &= KHI(Y, K_-). \end{aligned}$$

However, the situation for  $(M_0, \gamma_0)$  is a little different. The manifold  $M_0$  is obtained

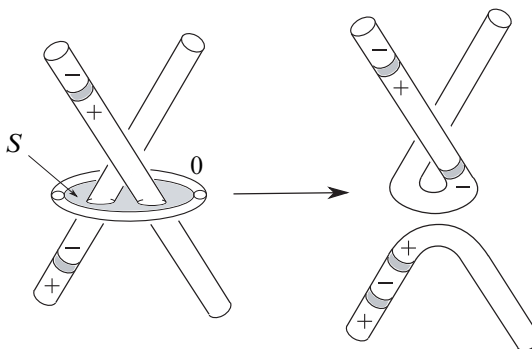

Figure 4: Decomposing  $M_0$  along a product annulus to obtain a link complement in  $S^3$

by zero-surgery on the circle  $\lambda$  in  $M_+$ , as indicated in Figure 3. This sutured manifold contains a product annulus  $S$ , consisting of the union of the twice-punctured disk shown in Figure 4 and a disk  $D^2$  in the surgery solid-torus  $S^1 \times D^2$ . As shown in the figure, sutured-manifold decomposition along the annulus  $S$  gives a sutured manifold  $(M'_0, \gamma'_0)$  in which  $M'_0$  is the link complement of  $K_0 \subset Y$ :

$$(M_0, \gamma_0) \xrightarrow{S} (M'_0, \gamma'_0).$$

By Proposition 6.7 of [7] (as adapted to the instanton homology setting in Section 7.5 of that paper), we therefore have an isomorphism

$$SHI(M_0, \gamma_0) \cong SHI(M'_0, \gamma'_0).$$

We now have to separate cases according to the number of components of  $K_+$  and  $K_0$ . If the two strands of  $K_+$  at the crossing belong to the same component, then every component of  $\partial M'_0$  contains exactly two, oppositely-oriented sutures, and we therefore have

$$SHI(M'_0, \gamma'_0) = KHI(Y, K_0).$$

In this case, the sequence (11) becomes the sequence in the first case of the theorem.

If the two strands of  $K_+$  belong to different components, then the corresponding boundary components of  $M_+$  each carry two sutures. These two boundary components

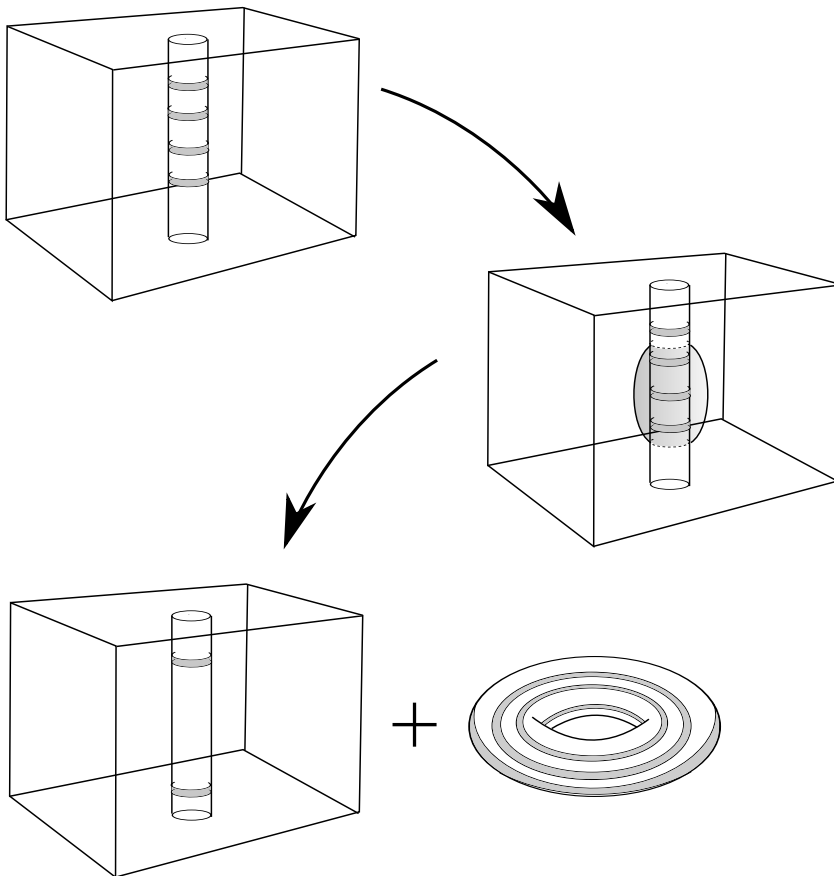

Figure 5: Removing some extra sutures using a decomposition along a product annulus. The solid torus in the last step has four sutures.

become one boundary component in  $M'_0$ , and the decomposition along  $S$  introduces two new sutures; so the resulting boundary component in  $M'_0$  carries six meridional sutures, with alternating orientations. Thus  $(M'_0, \gamma'_0)$  fails to be the sutured manifold associated to the link  $K_0 \subset Y$ , on account of having four additional sutures. As shown in Figure 5 however, the number of sutures on a torus boundary component can always be reduced by 2 (as long as there are at least four to start with) by using a decomposition along a separating annulus. This decomposition results in a manifold with one additional connected component, which is a solid torus with four longitudinal sutures. This operation needs to be performed twice to reduce the number of sutures in  $M'_0$  by four, so we obtain two copies of this solid torus. Denoting by  $V$  the Floer

homology of this four-sutured solid-torus, we therefore have

$$SHI(M'_0, \gamma'_0) = KHI(Y, K_0) \otimes V \otimes V$$

in this case. Thus the sequence (11) becomes the second long exact sequence in the theorem.

At this point, all that remains is to show that  $V$  is 2-dimensional, as asserted in the theorem. We will do this indirectly, by identifying  $V \otimes V$  as a 4-dimensional vector space. Let  $(M_4, \gamma_4)$  be the sutured solid-torus with 4 longitudinal sutures, as described above, so that  $SHI(M_4, \gamma_4) = V$ . Let  $(M, \gamma)$  be two disjoint copies of  $(M_4, \gamma_4)$ , so that

$$SHI(M, \gamma) = V \otimes V.$$

We can describe an admissible closure of  $(M, \gamma)$  (with a disconnected  $T$  as in Section 2.3) by taking  $T$  to be four annuli: we attach  $[-1, 1] \times T$  to  $(M, \gamma)$  to form  $\bar{M}$  so that  $\bar{M}$  is  $\Sigma \times S^1$  with  $\Sigma$  a four-punctured sphere. Thus  $\partial\bar{M}$  consists of four tori, two of which belong to  $\bar{R}_+$  and two to  $\bar{R}_-$ . The closure  $(Y, \bar{R})$  is obtained by gluing the tori in pairs; and this can be done so that  $Y$  has the form  $\Sigma_2 \times S^1$ , where  $\Sigma_2$  is now a closed surface of genus 2. The surface  $\bar{R}$  in  $\Sigma_2 \times S^1$  has the form  $\gamma \times S^1$ , where  $\gamma$  is a union of two disjoint closed curves in independent homology classes. The line bundle  $w$  has  $c_1(w)$  dual to  $\gamma'$ , where  $\gamma'$  is a curve on  $\Sigma_2$  dual to one component of  $\gamma$ .

Thus we can identify  $V \otimes V$  with the generalized eigenspace of  $\mu(y)$  belonging to the eigenvalue  $+2$  in the Floer homology  $I_*(\Sigma_2 \times S^1)_w$ ,

$$(12) \quad V \otimes V = I_*(\Sigma_2 \times S^1)_{w,+2},$$

where  $w$  is dual to a curve lying on  $\Sigma_2$ . Our next task is therefore to identify this Floer homology group. This was done (in slightly different language) by Braam and Donaldson [1, Proposition 1.15]. The main point is to identify the relevant representation variety in  $\mathcal{B}(Y)_w$ , for which we quote:

**Lemma 3.2** [1] *For  $Y = \Sigma_2 \times S^1$  and  $w$  as above, the critical-point set of the Chern–Simons functional in  $\mathcal{B}(Y)_w$  consists of two disjoint 2-tori. Furthermore, the Chern–Simons functional is of Morse–Bott type along its critical locus.* □

To continue the calculation, following [1], it now follows from the lemma that the Floer homology  $I_*(\Sigma_2 \times S^1)_w$  has dimension at most 8 and that the even and odd parts of this Floer group, with respect to the relative mod 2 grading, have equal dimension: each at most 4. On the other hand, the group  $I_*(\Sigma_2 \times S^1 | \Sigma_2)_w$  is nonzero. So the generalized eigenspaces belonging to the eigenvalue-pairs  $((-1)^r 2, i^r 2)$ , for  $r = 0, 1, 2, 3$ ,

are all nonzero. Indeed, each of these generalized eigenspaces is 1–dimensional, by Proposition 7.9 of [7]. These four 1–dimensional generalized eigenspaces all belong to the same relative mod 2 grading. It follows that  $I_*(\Sigma_2 \times S^1)_w$  is 8–dimensional, and can be identified as a vector space with the homology of the critical-point set. The generalized eigenspace belonging to  $+2$  for the operator  $\mu(\gamma)$  is therefore 4–dimensional; and this is  $V \otimes V$ . This completes the argument.  $\square$

### 3.2 Tracking the mod 2 grading

Because we wish to examine the Euler characteristics, we need to know how the canonical mod 2 grading behaves under the maps in Theorem 3.1. This is the content of the next lemma.

**Lemma 3.3** *In the situation of Theorem 3.1, suppose that the link  $K_+$  is null-homologous (so that  $K_-$  and  $K_0$  are null-homologous also). Let  $\Sigma_+$  be a Seifert surface for  $K_+$ , and let  $\Sigma_-$  and  $\Sigma_0$  be Seifert surfaces for the other two links, obtained from  $\Sigma_+$  by a modification in the neighborhood of the crossing. Equip the instanton knot homology groups of these links with their canonical mod 2 gradings, as determined by the preferred closures arising from these Seifert surfaces. Then in the first case of the two cases of the theorem, the map from  $KHI(Y, K_-)$  to  $KHI(Y, K_0)$  in the sequence (9) has odd degree, while the other two maps have even degree, with respect to the canonical mod 2 grading.*

*In the second case, if we grade the 4–dimensional vector space  $V \otimes V$  by identifying it with  $I_*(\Sigma_2 \times S^1)_{w,+2}$  as in (12), then the map from  $KHI(Y, K_0) \otimes V^{\otimes 2}$  to  $KHI(Y, K_+)$  in (10) has odd degree, while the other two maps have even degree.*

**Proof** We begin with the first case. Let  $Z_+$  be the preferred closure of the sutured knot complement  $(M_+, \gamma_+)$  obtained from the knot  $K_+$ , as defined by (6). In the notation of the proof of Theorem 3.1, the curve  $\lambda$  lies in  $Z_+$ . Let us write  $Z_-$  and  $Z_0$  for the manifolds obtained from  $Z_+$  by  $-1$ –surgery and  $0$ –surgery on  $\lambda$  respectively. It is a straightforward observation that  $Z_-$  and  $Z_0$  are respectively the preferred closures of the sutured complements of the links  $K_-$  and  $K_0$ . The surgery cobordism  $W$  from  $Z_+$  to  $Z_-$  gives rise to the map from  $KHI(Y, K_+)$  to  $KHI(Y, K_-)$ . This  $W$  has the same homology as the cylinder  $[-1, 1] \times Z_+$  blown up at a single point. The quantity  $\iota(W)$  in (8) is therefore even, and it follows that the map

$$KHI(Y, K_+) \rightarrow KHI(Y, K_-)$$

has even degree. The surgery cobordism  $W_0$  induces a map

$$(13) \quad I_*(Z_-)_w \rightarrow I_*(Z_0)_w$$



which has odd degree, by another application of (8). This concludes the proof of the first case.

In the second case of the theorem, we still have a long exact sequence

$$\rightarrow I_*(Z_+)w \rightarrow I_*(Z_-)w \rightarrow I_*(Z_0)w \rightarrow$$

in which the map  $I_*(Z_-)w \rightarrow I_*(Z_0)w$  is odd and the other two are even. However, it is no longer true that the manifold  $Z_0$  is the preferred closure of the sutured manifold obtained from  $K_0$ . The manifold  $Z_0$  can be described as being obtained from the complement of  $K_0$  by attaching  $G_r \times S^1$ , where  $G_r$  is a surface of genus 2 with  $r$  boundary components. Here  $r$  is the number of components of  $K_0$ , and the attaching is done as before, so that the curves  $\partial G_r \times \{q\}$  is attached to the longitudes and the curves  $\{p_i\} \times S^1$  are attached to the meridians. The preferred closure, on the other hand, is defined using a surface  $F_r$  of genus 1, not genus 2. We write  $Z'_0$  for the preferred closure, and our remaining task is to compare the instanton Floer homologies of  $Z_0$  and  $Z'_0$ , with their canonical  $\mathbb{Z}/2$  gradings.

An application of Floer’s excision theorem provides an isomorphism

$$I_*(Z_0)_{w,+2} \rightarrow I_*(Z'_0)_{w,+2} \otimes I_*(\Sigma_2 \times S^1)_{w,+2}$$

where (as before) the class  $w$  in the last term is dual to a nonseparating curve in the genus–2 surface  $\Sigma_2$ . (See Figure 6 which depicts the excision cobordism from  $G_r \times S^1$

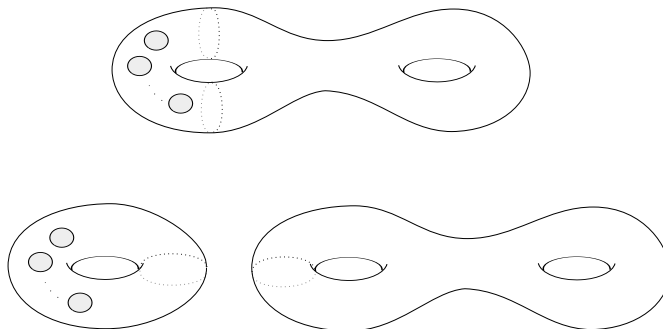

Figure 6: The surfaces  $G_r$  and  $F_r \sqcup \Sigma_2$ , used in constructing  $Z_0$  and  $Z'_0$  respectively

to  $(F_r \sqcup \Sigma_2) \times S^1$ , with the  $S^1$  factor suppressed.) The isomorphism is realized by an explicit cobordism  $W$ , with  $\iota(W)$  odd, which accounts for the difference between the first and second cases and concludes the proof. □

### 3.3 Tracking the eigenspace decomposition

The next lemma is similar in spirit to Lemma 3.3, but deals with eigenspace decomposition rather than the mod 2 grading.

**Lemma 3.4** *In the situation of Theorem 3.1, suppose again that the links  $K_+$ ,  $K_-$  and  $K_0$  are null-homologous. Let  $\Sigma_+$  be a Seifert surface for  $K_+$ , and let  $\Sigma_-$  and  $\Sigma_0$  be Seifert surfaces for the other two links, obtained from  $\Sigma_+$  by a modification in the neighborhood of the crossing. Then in the first case of the two cases of the theorem, the maps in the long exact sequence (9) intertwine the three operators  $\mu^o([\Sigma_+])$ ,  $\mu^o([\Sigma_-])$  and  $\mu^o([\Sigma_0])$ . In particular then, we have a long exact sequence*

$$\rightarrow KHI(Y, K_+, [\Sigma_+], j) \rightarrow KHI(Y, K_-, [\Sigma_-], j) \rightarrow KHI(Y, K_0, [\Sigma_0], j) \rightarrow$$

for every  $j$ .

In the second case of Theorem 3.1, the maps in the long exact sequence (10) intertwine the operators  $\mu^o([\Sigma_+])$  and  $\mu^o([\Sigma_-])$  on the first two terms with the operator

$$\mu^o([\Sigma_0]) \otimes 1 + 1 \otimes \mu([\Sigma_2])$$

acting on

$$KHI(Y, K_0) \otimes I_*(\Sigma_2 \times S^1)_{w,+2} \cong KHI(Y, K_0) \otimes V^{\otimes 2}.$$

**Proof** The operator  $\mu^o([\Sigma])$  on the knot homology groups is defined in terms of the action of  $\mu([\bar{\Sigma}])$  for a corresponding closed surface  $\bar{\Sigma}$  in the preferred closure of the link complement. The maps in the long exact sequences arise from cobordisms between the preferred closures. The lemma follows from the fact that the corresponding closed surfaces are homologous in these cobordisms.  $\square$

### 3.4 Proof of the main theorem

For a null-homologous link  $K \subset Y$  with a chosen Seifert surface  $\Sigma$ , let us write

$$\begin{aligned} \chi(Y, K, [\Sigma]) &= \sum_j \chi(KHI(Y, K, [\Sigma], j))t^j \\ &= \sum_j (\dim KHI_0(Y, K, [\Sigma], j) - \dim KHI_1(Y, K, [\Sigma], j))t^j \\ &= \text{str}(t^{\mu^o(\Sigma)/2}), \end{aligned}$$

where  $\text{str}$  denotes the alternating trace. If  $K_+$ ,  $K_-$  and  $K_0$  are three skein-related links with corresponding Seifert surfaces  $\Sigma_+$ ,  $\Sigma_-$  and  $\Sigma_0$ , then Theorem 3.1, Lemma 3.3

and Lemma 3.4 together tell us that we have the relation

$$\chi(Y, K_+, [\Sigma_+]) - \chi(Y, K_-, [\Sigma_-]) + \chi(Y, K_0, [\Sigma_0]) = 0$$

in the first case of Theorem 3.1, and

$$\chi(Y, K_+, [\Sigma_+]) - \chi(Y, K_-, [\Sigma_-]) - \chi(Y, K_0, [\Sigma_0])r(t) = 0$$

in the second case. Here  $r(t)$  is the contribution from the term  $I_*(\Sigma_2 \times S^1)_{w,+2}$ , so that

$$r(t) = \text{str}(t^{\mu([\Sigma_2])/2}).$$

From the proof of Lemma 3.2 we can read off the eigenvalues of  $[\Sigma_2]/2$ : they are 1, 0 and  $-1$ , and the  $\pm 1$  eigenspaces are each 1-dimensional. Thus

$$r(t) = \pm(t - 2 + t^{-1}).$$

To determine the sign of  $r(t)$ , we need to know the canonical  $\mathbb{Z}/2$  grading of (say) the 0-eigenspace of  $\mu([\Sigma_2])$  in  $I_*(\Sigma_2 \times S^1)_{w,+2}$ . The trivial 3-dimensional cobordism from  $T^2$  to  $T^2$  can be decomposed as  $N^+ \cup N^-$ , where  $N^+$  is a cobordism from  $T^2$  to  $\Sigma_2$  and  $N^-$  is a cobordism the other way. The 4-dimensional cobordisms  $W^\pm = N^\pm \times S^1$  induce isomorphisms on the 0-eigenspace of  $\mu([T^2]) = \mu([\Sigma_2])$ ; and  $\iota(W^\pm)$  is odd. Since the generator for  $T^3$  is in odd degree, we conclude that the 0-eigenspace of  $\mu([\Sigma_2])$  is in even degree, and that

$$\begin{aligned} r(t) &= -(t - 2 + t^{-1}) \\ &= -q(t)^2 \end{aligned}$$

where

$$q(t) = (t^{1/2} - t^{-1/2}).$$

We can roll the two case of Theorem 3.1 into one by defining the “normalized” Euler characteristic as

$$(14) \quad \tilde{\chi}(Y, K, [\Sigma]) = q(t)^{1-r} \chi(Y, K, [\Sigma])$$

where  $r$  is the number of components of the link  $K$ . With this notation we have:

**Proposition 3.5** *For null-homologous skein-related links  $K_+$ ,  $K_-$  and  $K_0$  with corresponding Seifert surface  $\Sigma_+$ ,  $\Sigma_-$  and  $\Sigma_0$ , the normalized Euler characteristics (14) satisfy*

$$\tilde{\chi}(Y, K_+, [\Sigma_+]) - \tilde{\chi}(Y, K_-, [\Sigma_-]) = (t^{1/2} - t^{-1/2}) \tilde{\chi}(Y, K_0, [\Sigma_0]). \quad \square$$

In the case of classical knots and links, we may write this simply as

$$\tilde{\chi}(K_+) - \tilde{\chi}(K_-) = (t^{1/2} - t^{-1/2}) \tilde{\chi}(K_0).$$

This is the exactly the skein relation of the (single-variable) normalized Alexander polynomial  $\Delta$ . The latter is normalized so that  $\Delta = 1$  for the unknot, whereas our  $\tilde{\chi}$  is  $-1$  for the unknot because the generator of its knot homology is in odd degree. We therefore have:

**Theorem 3.6** *For any link  $K$  in  $S^3$ , we have*

$$\tilde{\chi}(K) = -\Delta_K(t),$$

where  $\tilde{\chi}(K)$  is the normalized Euler characteristic (14) and  $\Delta_K$  is the Alexander polynomial of the link with Conway's normalization.  $\square$

In the case that  $K$  is a knot, we have  $\tilde{\chi}(K) = \chi(K)$ , which is the case given in Theorem 1.1 in the introduction.  $\square$

**Remark** The equality  $r(t) = -q(t)^2$  can be interpreted as arising from the isomorphism

$$I_*(\Sigma_2 \times S^1)_{w,+2} \cong V \otimes V,$$

with the additional observation that the isomorphism between these two is odd with respect to the preferred  $\mathbb{Z}/2$  gradings.

## 4 Applications

### 4.1 Fibered knots

In [7], the authors adapted the argument of Ni [11] to establish a criterion for a knot  $K$  in  $S^3$  to be a fibered knot: in particular, Corollary 7.19 of [7] states that  $K$  is fibered if the following three conditions hold:

- (1) The Alexander polynomial  $\Delta_K(T)$  is monic, in the sense that its leading coefficient is  $\pm 1$ .
- (2) The leading coefficient occurs in degree  $g$ , where  $g$  is the genus of the knot.
- (3) The dimension of  $KHI(K, g)$  is 1.

It follows from our Theorem 1.1 that the last of these three conditions implies the other two. So we have:

**Proposition 4.1** *If  $K$  is a knot in  $S^3$  of genus  $g$ , then  $K$  is fibered if and only if the dimension of  $KHI(K, g)$  is 1.  $\square$*

### 4.2 Counting representations

We describe some applications to representation varieties associated to classical knots  $K \subset S^3$ . The instanton knot homology  $KHI(K)$  is defined in terms of the preferred closure  $Z = Z(K)$  described at (6), and therefore involves the flat connections

$$\mathcal{R}(Z)_w \subset \mathcal{B}(Z)_w$$

in the space of connections  $\mathcal{B}(Z)_w$ : the quotient by the determinant–1 gauge group of the space of all  $PU(2)$  connections in  $\mathbb{P}(E_w)$ , where  $E_w \rightarrow Z$  is a  $U(2)$  bundle with  $\det(E) = w$ . If the space of these flat connections in  $\mathcal{B}(Z)_w$  is nondegenerate in the Morse–Bott sense when regarded as the set of critical points of the Chern–Simons functional, then we have

$$\dim I_*(Z)_w \leq \dim H_*(\mathcal{R}(Z)_w).$$

The generalized eigenspace  $I_*(Z)_{w,+2} \subset I_*(Z)_w$  has half the dimension of the total, so

$$\dim KHI(K) \leq \frac{1}{2} \dim H_*(\mathcal{R}(Z)_w).$$

As explained in [7], the representation variety  $\mathcal{R}(Z)_w$  is closely related to the space

$$\mathcal{R}(K, \mathbf{i}) = \{ \rho: \pi_1(S^3 \setminus K) \rightarrow SU(2) \mid \rho(m) = \mathbf{i} \},$$

where  $m$  is a chosen meridian and

$$\mathbf{i} = \begin{pmatrix} i & 0 \\ 0 & -i \end{pmatrix}.$$

More particularly, there is a two-to-one covering map

$$(15) \quad \mathcal{R}(Z)_w \rightarrow \mathcal{R}(K, \mathbf{i}).$$

The circle subgroup  $SU(2)^{\mathbf{i}} \subset SU(2)$  which stabilizes  $\mathbf{i}$  acts on  $\mathcal{R}(K, \mathbf{i})$  by conjugation. There is a unique reducible element in  $\mathcal{R}(K, \mathbf{i})$  which is fixed by the circle action; the remaining elements are irreducible and have stabilizer  $\pm 1$ . The most nondegenerate situation that can arise, therefore, is that  $\mathcal{R}(K, \mathbf{i})$  consists of a point (the reducible) together with finitely many circles, each of which is Morse–Bott. In such a case, the covering (15) is trivial. As in [6], the corresponding nondegeneracy condition at a flat connection  $\rho$  can be interpreted as the condition that the map

$$H^1(S^3 \setminus K; \mathfrak{g}_\rho) \rightarrow H^1(m; \mathfrak{g}_\rho) = \mathbb{R}$$

is an isomorphism. Here  $\mathfrak{g}_\rho$  is the local system on the knot complement with fiber  $\mathfrak{su}(2)$ , associated to the representation  $\rho$ . We therefore have:

**Corollary 4.2** *Suppose that the representation variety  $\mathcal{R}(K, \mathbf{i})$  associated to the complement of a classical knot  $K \subset S^3$  consists of the reducible representation and  $n(K)$  conjugacy classes of irreducibles, each of which is nondegenerate in the above sense. Then*

$$\dim KHI(K) \leq 1 + 2n(K).$$

**Proof** Under the given hypotheses, the representation variety  $\mathcal{R}(K, \mathbf{i})$  is a union of a single point and  $n(K)$  circles. Its total Betti number is therefore  $1 + 2n(K)$ . The representation variety  $\mathcal{R}(Z)_w$  is a trivial double cover (15), so the total Betti number of  $\mathcal{R}(Z)_w$  is twice as large,  $2 + 4n(K)$ . □

Combining this with Corollary 1.2, we obtain:

**Corollary 4.3** *Under the hypotheses of the previous corollary, we have*

$$\sum_{j=-d}^d |a_j| \leq 1 + 2n(K)$$

where the  $a_j$  are the coefficients of the Alexander polynomial. □

Among all the irreducible elements of  $\mathcal{R}(K, \mathbf{i})$ , we can distinguish the subset consisting of those  $\rho$  whose image is binary dihedral: contained, that is, in the normalizer of a circle subgroup whose infinitesimal generator  $J$  satisfies  $\text{Ad}(\mathbf{i})(J) = -J$ . If  $n'(K)$  denotes the number of such irreducible binary dihedral representations, then one has

$$|\det(K)| = 1 + 2n'(K).$$

(see Klassen [5]). On the other hand, the determinant  $\det(K)$  can also be computed as the value of the Alexander polynomial at  $-1$ : the alternating sum of the coefficients. Thus we have:

**Corollary 4.4** *Suppose that the Alexander polynomial of  $K$  fails to be alternating, in the sense that*

$$\left| \sum_{j=-d}^d (-1)^j a_j \right| < \sum_{j=-d}^d |a_j|.$$

Then either  $\mathcal{R}(K, \mathbf{i})$  contains some representations that are not binary dihedral, or some of the binary-dihedral representations are degenerate as points of this representation variety. □

This last corollary is nicely illustrated by the torus knot  $T(4, 3)$ . This knot is the first nonalternating knot in Rolfsen's tables [14], where it appears as  $8_{19}$ . The Alexander polynomial of  $8_{19}$  is not alternating in the sense of the corollary; and as the corollary suggests, the representation variety  $\mathcal{R}(8_{19}; \mathbf{i})$  contains representations that are not binary dihedral. Indeed, there are representations whose image is the binary octahedral group in  $SU(2)$ .

## References

- [1] **P J Braam, S K Donaldson**, *Floer's work on instanton homology, knots and surgery*, from: "The Floer memorial volume", (H Hofer, C H Taubes, A Weinstein, E Zehnder, editors), Progr. Math. 133, Birkhäuser, Basel (1995) 195–256 MR1362829
- [2] **S K Donaldson**, *Floer homology groups in Yang–Mills theory*, Cambridge Tracts in Math. 147, Cambridge Univ. Press (2002) MR1883043 With the assistance of M Furuta and D Kotschick
- [3] **A Floer**, *Instanton homology, surgery, and knots*, from: "Geometry of low-dimensional manifolds, 1 (Durham, 1989)", (S K Donaldson, C B Thomas, editors), London Math. Soc. Lecture Note Ser. 150, Cambridge Univ. Press (1990) 97–114 MR1171893
- [4] **A Juhász**, *Holomorphic discs and sutured manifolds*, *Algebr. Geom. Topol.* 6 (2006) 1429–1457 MR2253454
- [5] **E P Klassen**, *Representations of knot groups in  $SU(2)$* , *Trans. Amer. Math. Soc.* 326 (1991) 795–828 MR1008696
- [6] **P Kronheimer, T Mrowka**, *Knot homology groups from instantons* arXiv:0806.1053
- [7] **P Kronheimer, T Mrowka**, *Knots, sutures and excision* arXiv:0807.4891
- [8] **P Kronheimer, T Mrowka**, *Monopoles and three-manifolds*, New Math. Monographs 10, Cambridge Univ. Press (2007) MR2388043
- [9] **Y Lim**, *Instanton homology and the Alexander polynomial*, *Proc. Amer. Math. Soc.* 138 (2010) 3759–3768
- [10] **V Muñoz**, *Ring structure of the Floer cohomology of  $\Sigma \times S^1$* , *Topology* 38 (1999) 517–528 MR1670396
- [11] **Y Ni**, *Knot Floer homology detects fibred knots*, *Invent. Math.* 170 (2007) 577–608 MR2357503
- [12] **P Ozsváth, Z Szabó**, *Holomorphic disks and knot invariants*, *Adv. Math.* 186 (2004) 58–116 MR2065507
- [13] **J A Rasmussen**, *Floer homology and knot complements*, ProQuest LLC, Ann Arbor, MI (2003) MR2619970 PhD Thesis–Harvard University

- [14] **D Rolfsen**, *Knots and links*, Math. Lecture Ser. 7, Publish or Perish, Houston, TX (1990) MR1277811

*Department of Mathematics, Harvard University  
Cambridge MA 02138*

*Department of Mathematics, Massachusetts Institute of Technology  
Cambridge MA 02139*

kronheim@math.harvard.edu, mrowka@math.mit.edu

Received: 27 July 2009      Revised: 2 June 2010