

A mathematical theory of the topological vertex

JUN LI
 CHIU-CHU MELISSA LIU
 KEFENG LIU
 JIAN ZHOU

We have developed a mathematical theory of the topological vertex—a theory that was originally proposed by M Aganagic, A Klemm, M Mariño and C Vafa on effectively computing Gromov–Witten invariants of smooth toric Calabi–Yau threefolds derived from duality between open string theory of smooth Calabi–Yau threefolds and Chern–Simons theory on three-manifolds.

14N35, 53D45; 57M27

1 Introduction

In [1], M Aganagic, A Klemm, M Mariño and C Vafa proposed a theory on computing Gromov–Witten invariants in all genera of any smooth toric Calabi–Yau threefold; their theory is derived from duality between open string theory of smooth Calabi–Yau threefolds and Chern–Simons theory on 3–manifolds. The following is a summary of their theory:

- (O1) There exist certain open Gromov–Witten invariants that count holomorphic maps from bordered Riemann surfaces to \mathbb{C}^3 with boundaries mapped to three specific Lagrangian submanifolds L_1, L_2 and L_3 . Such invariants depend on the topological type of the domain (classified by the genus and the number of boundary circles), the topological type of the map and the “framing” $n_i \in \mathbb{Z}$ of the Lagrangian submanifolds L_i ($i = 1, 2, 3$). The topological type of the map is described by a triple of partitions $\vec{\mu} = (\mu^1, \mu^2, \mu^3)$ where μ^i consists of the degrees (“winding numbers”) of the boundary circles in $L_i \cong S^1 \times \mathbb{C}$. The *topological vertex*

$$C_{\vec{\mu}}(\lambda; \mathbf{n})$$

is a generating function of such invariants. Here we fix the winding numbers $\vec{\mu} = (\mu^1, \mu^2, \mu^3)$, the framings $\mathbf{n} = (n_1, n_2, n_3)$ and sum over the genus of the domains.

- (O2) The Gromov–Witten invariants of any smooth toric Calabi–Yau threefold can be expressed in terms of $C_{\bar{\mu}}(\lambda; \mathbf{n})$ by explicit gluing algorithms.
- (O3) By the duality between Chern–Simons theory and Gromov–Witten theory, the topological vertex is given by

$$C_{\bar{\mu}}(\lambda; \mathbf{n}) = q^{\frac{1}{2}(\sum_{i=1}^3 \kappa_{\nu_i} n_i)} \mathcal{W}_{\bar{\mu}}(q), \quad q = e^{\sqrt{-1}\lambda},$$

where $\mathcal{W}_{\bar{\mu}}(q)$ is a combinatorial expression related to the Chern–Simons link invariants (cf Section 2.1).

As was demonstrated in the work of many, for instance Peng [34] and Konishi [17; 16], this algorithm is extremely efficient in deriving the structure result of the Gromov–Witten invariants of toric Calabi–Yau threefolds.

The purpose of this paper is to provide a mathematical theory for this algorithm. To achieve this, we need to provide a mathematical definition of the open Gromov–Witten invariants referred to in (O1), we need to establish the gluing algorithms (O2) and we need to prove the duality (O3).

Based on relative Gromov–Witten theory (see Li and Rua [18], Ionel and Parker [12; 13] and Li [19; 20]), in this paper, we shall complete the first two steps as outlined. The following is a summary of our theory:

- (R1) We introduce the notion of formal toric Calabi–Yau (FTCY) graphs, which is a refinement and generalization of the graph associated to a toric Calabi–Yau threefold. Associated to an FTCY graph Γ , we construct a relative FTCY threefold $Y^{\text{rel}} = (\hat{Y}, \hat{D})$.
- (R2) We define *formal relative Gromov–Witten invariants* for relative FTCY threefolds (Theorem 4.8). These invariants include as special cases Gromov–Witten invariants of smooth toric Calabi–Yau threefolds.
- (R3) We show that the formal relative Gromov–Witten invariants in (R2) satisfy the degeneration formula of relative Gromov–Witten invariants of projective varieties (Theorem 7.5).
- (R4) Any smooth relative FTCY threefold can be degenerated to indecomposable ones. By degeneration formula, the formal relative Gromov–Witten invariants in (R2) can be expressed in terms of the generating function $\tilde{C}_{\bar{\mu}}(\lambda; \mathbf{n})$ of indecomposable FTCY threefolds (Proposition 7.4). This degeneration formula coincides with the gluing algorithms described in (O2).

(R5) We evaluate $\tilde{C}_{\tilde{\mu}}(\lambda; \mathbf{n})$ (Proposition 6.5, Theorem 8.1):

$$\tilde{C}_{\tilde{\mu}}(\lambda; \mathbf{n}) = q^{\frac{1}{2}(\sum_{i=1}^3 \kappa_{v^i} n_i)} \tilde{\mathcal{W}}_{\tilde{\mu}}(q)$$

in terms of $\tilde{\mathcal{W}}_{\tilde{\mu}}(q)$, a combinatorial expression defined by (2-7) in Section 2.1.

In (R4), we shall define $\tilde{C}_{\tilde{\mu}}(\lambda; \mathbf{n})$ as local relative Gromov–Witten invariants of a formal Calabi–Yau (\hat{Z}, \hat{D}) that is the infinitesimal neighborhood of a configuration $C_1 \cup C_2 \cup C_3$ of three \mathbb{P}^1 ’s meeting at a point p_0 in a relative Calabi–Yau threefold (Z, D) ; the stable maps have ramification partition μ^i around the relative divisor D . Since \hat{Z} is formal, we shall define the local invariants $\tilde{C}_{\tilde{\mu}}$ via localization formula; $\tilde{C}_{\tilde{\mu}}$ can be expressed in terms of a generating function $G_{\mathbf{v}}^{\bullet}(\lambda; \mathbf{w})$ of three-partition Hodge integrals:

$$(1-1) \quad \tilde{C}_{\tilde{\mu}} = q^{\frac{1}{2} \sum_{i=1}^3 \kappa_{v^i} (n_i - w_{i+1}/w_i)} \sum_{|v^i|=|\mu^i|} G_{\mathbf{v}}^{\bullet}(\lambda; \mathbf{w}) \prod_{i=1}^3 \chi_{\mu^i}(v^i)$$

(See Section 2 for precise definitions involved in the right hand side of (1-1); $\mathbf{w} = (w_1, w_2, w_3)$ are equivariant parameters.) The most technical part of this paper is to show that local invariants $\tilde{C}_{\tilde{\mu}}$ exist as *topological* invariants; namely $\tilde{C}_{\tilde{\mu}} = \tilde{C}_{\tilde{\mu}}(\lambda; \mathbf{n})$ is independent of equivariant parameters \mathbf{w} (Theorem 5.2, invariance of the topological vertex). By the invariance of the topological vertex, to evaluate $\tilde{C}_{\tilde{\mu}}$ it suffices to evaluate $G_{\mathbf{v}}^{\bullet}(\lambda; \mathbf{w})$ at some \mathbf{w} . It turns out that at $\mathbf{w} = (1, 1, -2)$ we can reduce the evaluation of $G_{\mathbf{v}^1, \mathbf{v}^2, \mathbf{v}^3}^{\bullet}(1, 1, -2)$ to the evaluation of two-partition Hodge integrals $G_{\emptyset, \mu^+, \mu^-}^{\bullet}(1, 1, -2)$ (the first partition is empty). We then use a formula of two-partition Hodge integrals proved by the last three authors [23] to derive the combinatorial expression $\tilde{\mathcal{W}}_{\tilde{\mu}}$ in (R5). Inverting (1-1), we obtain a formula of three-partition Hodge integrals (Theorem 8.2):

$$G_{\tilde{\mu}}^{\bullet}(\lambda; \mathbf{w}) = \sum_{|v^i|=|\mu^i|} \prod_{i=1}^3 \frac{\chi_{v^i}(\mu^i)}{z_{\mu^i}} q^{\frac{1}{2}(\sum_{i=1}^3 \kappa_{v^i} w_{i+1}/w_i)} \tilde{\mathcal{W}}_{\tilde{\mu}}(q).$$

This generalizes the formula of two-partition Hodge integrals proved in [23].

Our results (R1)–(R5), together with a conjectural identity $\tilde{\mathcal{W}}_{\tilde{\mu}}(q) = \mathcal{W}_{\tilde{\mu}}(q)$ (Conjecture 8.3), will provide a complete mathematical theory of the topological vertex theory. The conjecture holds when one of the partitions, say μ^3 , is empty (Corollary 8.8); it also holds for all low degree cases we have checked.

An important class of toric Calabi–Yau threefolds consists of local toric surfaces in a Calabi–Yau threefold. Such threefolds are the total spaces of the canonical line bundles

of projective toric surfaces (eg $\mathcal{O}_{\mathbb{P}^2}(-3)$). For these threefolds, only $\tilde{C}_{\mu^1, \mu^2, \emptyset}(\lambda; \mathbf{n})$ (or two-partition Hodge integrals) are required to evaluate their Gromov–Witten invariants. The algorithm in this case was described by Aganagic, Mariño and Vafa [2]; an explicit formula was given by Iqbal [14] and derived by Zhou [37] by localization, using the formula of two-partition Hodge integrals.

It is worth mentioning that, assuming the existence of $C_{\tilde{\mu}}(\lambda; \mathbf{n})$ and the validity of open string virtual localization, Diaconescu and Florea related $C_{\tilde{\mu}}(\lambda; n_1, n_2, n_3)$ (at certain fractional n_i) to three-partition Hodge integrals, and derived the gluing algorithms in (O2) by localization [5].

Maulik, Nekrasov, Okounkov and Pandharipande conjectured a correspondence between the Gromov–Witten and Donaldson–Thomas theories for any nonsingular projective threefold [26; 27]. This correspondence can also be formulated for certain noncompact threefolds in the presence of a torus action; the correspondence for toric Calabi–Yau threefolds is equivalent to the validity of the topological vertex [26; 31]. For non–Calabi–Yau toric threefolds the building block is the equivariant vertex (see Maulik, Nekrasov, Okounkov and Pandharipande [26; 27] and Pandharipande and Thomas [33; 32] which depends on equivariant parameters. During the revision of this paper, Maulik, Oblomkov, Okounkov and Pandharipande announced a proof of GW/DT correspondence for all toric threefolds [28]. The results in [28] yield a proof of Conjecture 8.3.

The rest of this paper is organized as follows. In Section 2, we recall some definitions and previous results, and introduce some generating functions. The item (R1) is carried out in Section 3; the item (R2) is carried out in Section 4; it gives a mathematical definition of topological vertex when the relative FTCY threefold is indecomposable. We will prove the invariance, Theorem 5.2, in Section 5. In Section 6, we express the topological vertex in terms of three-partition Hodge integrals and double Hurwitz numbers. In the next two sections, we establish (R3) and (R4), and derive the combinatorial expression in (R5). Some examples of the identity $\mathcal{W}_{\tilde{\mu}}(q) = \tilde{\mathcal{W}}_{\tilde{\mu}}(q)$ are listed in Section 8.4. The Appendix contains a list of notation in this paper.

Acknowledgments We wish to thank A Aganagic, A Klemm, M Mariño, and C Vafa for their explanation of [1] in public lectures and private conversations. We also wish to thank S Katz and E Diaconescu for helpful conversations. We thank A Klemm for writing a Maple program which computes both $\mathcal{W}_{\tilde{\mu}}(q)$ and $\tilde{\mathcal{W}}_{\tilde{\mu}}(q)$. The first author is supported by NSF grant DMS-0200477 and DMS-0244550. The third author is supported by the NSF and the Guggenheim foundation. The fourth author is supported by NSFC grants 10425101 and 10631050 and a 973 Project grant NKBRPC(2006cB805905).

2 Definitions and previous results

In this section, we will introduce some notation, recall some known results, and define some generating functions. Generating functions in this paper are formal power series.

2.1 Partitions and representations of symmetric groups

We begin with the partitions and representations of symmetric groups. Recall that a *partition* μ of a nonnegative integer d , written as $\mu \vdash d$ or $|\mu| = d$, is a sequence of positive integers

$$\mu = (\mu_1 \geq \mu_2 \geq \dots \geq \mu_h > 0) \quad \text{such that} \quad d = \mu_1 + \dots + \mu_h.$$

We call $\ell(\mu) = h$ the *length* of the partition μ . For convenience, we denote by \emptyset the empty partition; thus $|\emptyset| = \ell(\emptyset) = 0$. The order of $\text{Aut}(\mu)$, the group of permutations of μ_1, μ_2, \dots that leave μ fixed, is

$$|\text{Aut}(\mu)| = \prod_{j>0} m_j(\mu)!, \quad \text{where} \quad m_j(\mu) = \#\{i : \mu_i = j\}.$$

The *transpose* of μ is the partition μ^t defined by $m_i(\mu^t) = \mu_i - \mu_{i+1}$. Note that

$$|\mu^t| = |\mu|, \quad (\mu^t)^t = \mu, \quad \ell(\mu^t) = \mu_1.$$

A partition μ corresponds to a conjugacy class in S_d in the obvious way. Here S_d is the permutation group of $d = |\mu|$ elements. With this understanding, the cardinality z_μ of the centralizer of any element in this conjugacy class is

$$z_\mu = a_\mu |\text{Aut}(\mu)|, \quad \text{where} \quad a_\mu = \mu_1 \cdots \mu_{\ell(\mu)}.$$

We let \mathcal{P} be the set of all partitions; $\mathcal{P}^2 = \mathcal{P} \times \mathcal{P}$ the product, and let

$$\mathcal{P}_+ = \mathcal{P} - \{\emptyset\}, \quad \mathcal{P}_+^2 = \mathcal{P}^2 - \{(\emptyset, \emptyset)\}, \quad \mathcal{P}_+^3 = \mathcal{P}^3 - \{(\emptyset, \emptyset, \emptyset)\}.$$

Given a triple of partitions $\vec{\mu} = (\mu^1, \mu^2, \mu^3) \in \mathcal{P}^3$, we define

$$\ell(\vec{\mu}) = \sum_{i=1}^3 \ell(\mu^i), \quad \text{Aut}(\vec{\mu}) = \prod_{i=1}^3 \text{Aut}(\mu^i).$$

For any partition ν , we let χ_ν denote the irreducible character of $S_{|\nu|}$ indexed by ν , and let $\chi_\nu(\mu)$ be the value of χ_ν on the conjugacy class determined by the partition μ . Recall that the Schur functions s_μ are related to the Newton functions $p_i(x) =$

$x_1^i + x_2^i + \dots$ by

$$s_\mu(x) = \sum_{\nu \vdash |\mu|} \frac{\chi_\mu(\nu)}{z_\nu} p_\nu(x), \quad x = (x_1, x_2, \dots),$$

where

$$p_\nu(x) = p_{\nu_1}(x) \cdots p_{\nu_{\ell(\nu)}}(x).$$

The Littlewood–Richardson coefficients $c_{\mu\nu}^\eta$, which are nonnegative integers, and the skew Schur functions $s_{\eta/\mu}$ are related by the rules

$$(2-1) \quad s_\mu s_\nu = \sum_{\eta} c_{\mu\nu}^\eta s_\eta \quad \text{and} \quad s_{\eta/\mu} = \sum_{\nu} c_{\mu\nu}^\eta s_\nu$$

where

$$(2-2) \quad c_{\mu\nu}^\eta = 0 \quad \text{unless} \quad |\eta| = |\mu| + |\nu|.$$

The ranges of summations in (2-1), and of all other summations involving Littlewood–Richardson coefficients $c_{\mu\nu}^\eta$, are determined by (2-2).

In order to define the combinatorial expressions $\mathcal{W}_{\tilde{\mu}}(q)$ and $\tilde{\mathcal{W}}_{\tilde{\mu}}(q)$ in (O3) and (R5) in the introduction (Section 1), we need to introduce more notation. We define $[m] = q^{m/2} - q^{-m/2}$, and define

$$(2-3) \quad \kappa_\mu = \sum_{i=1}^{\ell(\mu)} \mu_i (\mu_i - 2i + 1).$$

Note that for transpose partitions, it satisfies $\kappa_{\mu^t} = -\kappa_\mu$.

We next define

$$(2-4) \quad \mathcal{W}_\mu(q) = q^{\kappa_\mu/4} \prod_{1 \leq i < j \leq \ell(\mu)} \frac{[\mu_i - \mu_j + j - i]}{[j - i]} \prod_{i=1}^{\ell(\mu)} \prod_{v=1}^{\mu_i} \frac{1}{[v - i + \ell(\mu)]}.$$

Recall that any symmetric function f can be written as a polynomial $f(e_1, e_2, \dots)$ in the elementary symmetric functions e_1, e_2, \dots . Let $E(t) = 1 + \sum_{n=1}^{\infty} e_n t^n$. We write $f(e_1, e_2, \dots)$ as $f(E(t))$. With this notation, we define

$$(2-5) \quad \mathcal{W}_{\mu,\nu}(q) = q^{|\nu|/2} \mathcal{W}_\mu(q) \cdot s_\nu(\mathcal{E}_\mu(q, t)),$$

where

$$\mathcal{E}_\mu(q, t) = \prod_{j=1}^{\ell(\mu)} \frac{1 + q^{\mu_j - j} t}{1 + q^{-j} t} \cdot \left(1 + \sum_{n=1}^{\infty} \frac{t^n}{\prod_{i=1}^n (q^i - 1)} \right).$$

We introduce

$$c_{\rho^1(\rho^3)^t}^{\mu^1(\mu^3)^t} = \sum_{\eta} c_{\eta\rho^1}^{\mu^1} c_{\eta(\rho^3)^t}^{\mu^3}.$$

Definition 2.1 For $\vec{\mu} = (\mu^1, \mu^2, \mu^3)$, we define

$$(2-6) \quad \mathcal{W}_{\vec{\mu}}(q) = q^{\kappa_{\mu^2/2 + \kappa_{\mu^3/2}}} \sum_{\rho^1, \rho^3} c_{\rho^1(\rho^3)^t}^{\mu^1(\mu^3)^t} \frac{\mathcal{W}_{(\mu^2)^t \rho^1}(q) \mathcal{W}_{\mu^2(\rho^3)^t}(q)}{\mathcal{W}_{\mu^2}(q)}.$$

As a convention, we define the double of a partition $\mu = (\mu_1 \geq \mu_2 \geq \dots)$ to be $2\mu = (2\mu_1 \geq 2\mu_2 \geq \dots)$.

Definition 2.2 For $\vec{\rho} = (\rho^1, \rho^2, \rho^3)$, we define

$$(2-7) \quad \begin{aligned} \tilde{\mathcal{W}}_{\vec{\rho}}(q) &= q^{-(\kappa_{\rho^1} - 2\kappa_{\rho^2} - \frac{1}{2}\kappa_{\rho^3})/2} \sum_{v^+, \eta^1, v^1, \eta^3, v^3} c_{(v^1)^t \rho^2}^{v^+} c_{(\eta^1)^t v^1}^{\rho^1} c_{\eta^3(v^3)^t}^{\rho^3} \\ &\cdot q^{(-2\kappa_{v^+} - \frac{\kappa_{v^3}}{2})/2} \mathcal{W}_{v^+, v^3}(q) \sum_{\mu \vdash |\eta^1|} \frac{1}{z_{\mu}} \chi_{\eta^1}(\mu) \chi_{\eta^3}(2\mu). \end{aligned}$$

$\mathcal{W}_{\vec{\mu}}$ and $\tilde{\mathcal{W}}_{\vec{\mu}}$ are rational functions in $q^{1/2}$. We have the following identities (see Zhou [36]):

$$\begin{aligned} \mathcal{W}_{\mu, v, \emptyset}(q) &= \mathcal{W}_{\emptyset, \mu, v}(q) = \mathcal{W}_{v, \emptyset, \mu}(q) = q^{\kappa_v/2} \mathcal{W}_{\mu, (v)^t}(q). \\ \mathcal{W}_{\mu, v}(q) &= \mathcal{W}_{v, \mu}(q), \quad \mathcal{W}_{\mu, \emptyset}(q) = \mathcal{W}_{\mu}(q). \end{aligned}$$

2.2 Double Hurwitz numbers

We now come to the generating function of double Hurwitz numbers. Let μ^+, μ^- be partitions of d ; let $H_{\chi, \mu^+, \mu^-}^{\bullet}$ be the weighted counts of Hurwitz covers of the sphere of the type (μ^+, μ^-) by possibly disconnected Riemann surfaces of Euler characteristic χ . We form the generating function

$$\Phi_{\mu^+, \mu^-}^{\bullet}(\lambda) = \sum_{\chi \in 2\mathbb{Z}} \lambda^{-\chi + \ell(\mu^+) + \ell(\mu^-)} \frac{H_{\chi, \mu^+, \mu^-}^{\bullet}}{(-\chi + \ell(\mu^+) + \ell(\mu^-))!}.$$

By Burnside formula,

$$(2-8) \quad \Phi_{\mu^+, \mu^-}^{\bullet}(\lambda) = \sum_{v \vdash d} e^{\kappa_v \lambda/2} \frac{\chi_v(\mu^+)}{z_{\mu^+}} \frac{\chi_v(\mu^-)}{z_{\mu^-}}.$$

Using the orthogonality of characters

$$\sum_{\rho \vdash d} \frac{\chi_{\mu}(\rho)\chi_{\nu}(\rho)}{z_{\rho}} = \delta_{\mu\nu},$$

it is straightforward to check that (2-8) implies the following two identities:

$$(2-9) \quad \Phi_{\mu^+, \mu^-}^{\bullet}(\lambda_1 + \lambda_2) = \sum_{\nu \vdash d} \Phi_{\mu^+, \nu}^{\bullet}(\lambda_1) z_{\nu} \Phi_{\nu, \mu^-}^{\bullet}(\lambda_2)$$

and

$$(2-10) \quad \Phi_{\mu^+, \mu^-}^{\bullet}(0) = \frac{\delta_{\mu^+, \mu^-}}{z_{\mu^+}}.$$

Equation (2-9) is a sum formula for double Hurwitz numbers; Equation (2-10) gives the initial values for the double Hurwitz numbers.

We now introduce a differential equation. It has the property that its unique solution satisfying the initial condition (2-10) is a generating function of $\Phi_{\mu^+, \mu^-}^{\bullet}$. This equation is similar to [9, Lemma 2.2] and [10, Lemma 3.1] (see also Goulden [8]).

We let $p^{\pm} = (p_1^{\pm}, p_2^{\pm}, \dots)$ be formal variables, and for a partition μ we let $p_{\mu}^{\pm} = p_{\mu_1}^{\pm} \cdots p_{\mu_{\ell(\mu)}}^{\pm}$. We then define a generating function

$$\Phi^{\bullet}(\lambda; p^+, p^-) = 1 + \sum_{d=1}^{\infty} \sum_{|\mu^{\pm}|=d} \Phi_{\mu^+, \mu^-}^{\bullet}(\lambda) p_{\mu^+}^+ p_{\mu^-}^-,$$

and differential operators

$$C^{\pm} = \sum_{j,k=1}^{\infty} (j+k) p_j^{\pm} p_k^{\pm} \frac{\partial}{\partial p_{j+k}^{\pm}}, \quad J^{\pm} = \sum_{j,k=1}^{\infty} jk p_{j+k}^{\pm} \frac{\partial^2}{\partial p_j^{\pm} \partial p_k^{\pm}}.$$

They form a *cut-and-join equation* for double Hurwitz numbers:

$$\frac{\partial \Phi^{\bullet}}{\partial \lambda} = \frac{1}{2}(C^+ + J^+) \Phi^{\bullet} = \frac{1}{2}(C^- + J^-) \Phi^{\bullet}.$$

The generating function $\Phi^{\bullet}(\lambda; p^+, p^-)$ is the unique solution to this system satisfying the initial value

$$\Phi^{\bullet}(0; p^+, p^-) = 1 + \sum_{\mu \in \mathcal{P}^+} \frac{p_{\mu}^+ p_{\mu}^-}{z_{\mu}}.$$

2.3 Three-partition Hodge integrals

We shall introduce three-partition Hodge integrals in this subsection.

For the three-partition Hodge integrals we need to work with the Deligne–Mumford moduli stack $\overline{\mathcal{M}}_{g,n}$ of stable n -pointed nodal curves of genus g . Over this moduli stack, we let $\pi: \overline{\mathcal{M}}_{g,n+1} \rightarrow \overline{\mathcal{M}}_{g,n}$ be the universal curve; let $s_i: \overline{\mathcal{M}}_{g,n} \rightarrow \overline{\mathcal{M}}_{g,n+1}$ be the section of the i -th marked points of the family, and let ω_π be the relative dualizing sheaf. The commonly known λ classes and the ψ -classes are defined using these morphisms: the λ class λ_j is the j -th Chern class $\lambda_j = c_j(\mathbb{E})$ of the Hodge bundle $\mathbb{E} = \pi_*\omega_\pi$, and the ψ class ψ_i is the first Chern class $\psi_i = c_1(\mathbb{L}_i)$ of the pull back line bundle $\mathbb{L}_i = s_i^*\omega_\pi$. A Hodge integral is then an integral of the form

$$\int_{\overline{\mathcal{M}}_{g,n}} \psi_1^{j_1} \dots \psi_n^{j_n} \lambda_1^{k_1} \dots \lambda_g^{k_g}.$$

We now introduce three-partition Hodge integrals. Let w_1, w_2, w_3 be formal variables. In this subsection, and in Sections 6, 7 and 8, we shall follow the convention:

$$(2-11) \quad \mathbf{w} = (w_1, w_2, w_3), \quad w_1 + w_2 + w_3 = 0, \quad w_4 = w_1.$$

For $\vec{\mu} = (\mu^1, \mu^2, \mu^3) \in \mathcal{P}_+^3$, we let

$$d_{\vec{\mu}}^1 = 0, \quad d_{\vec{\mu}}^2 = \ell(\mu^1), \quad d_{\vec{\mu}}^3 = \ell(\mu^1) + \ell(\mu^2).$$

We define the *three-partition Hodge integral*

$$G_{g,\vec{\mu}}(\mathbf{w}) = \frac{(-\sqrt{-1})^{\ell(\vec{\mu})}}{|\text{Aut}(\vec{\mu})|} \prod_{i=1}^3 \prod_{j=1}^{\ell(\mu^i)} \frac{\prod_{a=1}^{\mu_j^i-1} (\mu_j^i w_{i+1} + a w_i)}{(\mu_j^i - 1)! w_i^{\mu_j^i-1}} \int_{\overline{\mathcal{M}}_{g,\ell(\vec{\mu})}} \times \prod_{i=1}^3 \frac{\Lambda_g^\vee(w_i) w_i^{\ell(\vec{\mu})-1}}{\prod_{j=1}^{\ell(\mu^i)} (w_i (w_i - \mu_j^i \psi_{d_{\vec{\mu}}^i+j}))}$$

where $\Lambda_g^\vee(u) = u^g - \lambda_1 u^{g-1} + \dots + (-1)^g \lambda_g$.

It is clear from the definition that $G_{g,\vec{\mu}}(\mathbf{w})$ obeys the cyclic symmetry:

$$(2-12) \quad G_{g,\mu^1,\mu^2,\mu^3}(w_1, w_2, w_3) = G_{g,\mu^2,\mu^3,\mu^1}(w_2, w_3, w_1).$$

Since $\sqrt{-1}^{\ell(\vec{\mu})} G_{g,\vec{\mu}}(\mathbf{w})$ is a homogeneous degree 0 rational function in w_1, w_2, w_3 with \mathbb{Q} -coefficients (where $\deg w_1 = \deg w_2 = \deg w_3 = 2$), we will substitute \mathbf{w} by $\mathbf{w} = (1, \tau, -\tau - 1)$. For such weights, we will write

$$G_{g,\vec{\mu}}(\tau) = G_{g,\vec{\mu}}(1, \tau, -\tau - 1).$$

Then (2-12) becomes

$$G_{g,\mu^1,\mu^2,\mu^3}(\tau) = G_{g,\mu^2,\mu^3,\mu^1}\left(-1 - \frac{1}{\tau}\right) = G_{g,\mu^3,\mu^1,\mu^2}\left(\frac{-1}{\tau + 1}\right).$$

We let λ and $p^i = (p_1^i, p_2^i, \dots)$ be formal variables; given a partition μ we define $p_\mu^i = p_1^i \cdots p_{\ell(\mu)}^i$; (note $p_\emptyset^i = 1$); for p^1, p^2 and p^3 , we abbreviate

$$\mathbf{p} = (p^1, p^2, p^3) \quad \text{and} \quad \mathbf{p}_{\tilde{\mu}} = p_{\mu^1}^1 p_{\mu^2}^2 p_{\mu^3}^3.$$

We define the three-partition-Hodge-integral generating functions to be

$$G_{\tilde{\mu}}(\lambda; \mathbf{w}) = \sum_{g=0}^{\infty} \lambda^{2g-2+\ell(\tilde{\mu})} G_{g,\tilde{\mu}}(\mathbf{w}) \quad \text{and} \quad G(\lambda; \mathbf{p}; \mathbf{w}) = \sum_{\tilde{\mu} \in \mathcal{P}_+^3} G_{\tilde{\mu}}(\lambda; \mathbf{w}) \mathbf{p}_{\tilde{\mu}};$$

we define the same generating functions for not necessarily connected domain curves to be

$$(2-13) \quad G^\bullet(\lambda; \mathbf{p}; \mathbf{w}) = \exp(G(\lambda; \mathbf{p}; \mathbf{w})) = 1 + \sum_{\tilde{\mu} \in \mathcal{P}_+^3} G_{\tilde{\mu}}^\bullet(\lambda; \mathbf{w}) \mathbf{p}_{\tilde{\mu}}$$

$$(2-14) \quad G_{\tilde{\mu}}^\bullet(\lambda; \mathbf{w}) = \sum_{\chi \in 2\mathbb{Z}} \lambda^{-\chi+\ell(\tilde{\mu})} G_{\chi,\tilde{\mu}}^\bullet(\mathbf{w});$$

we define $G_{\tilde{\mu}}(\lambda; \tau), G(\lambda; \mathbf{p}; \tau), G^\bullet(\lambda; \mathbf{p}; \tau)$ and $G_{\tilde{\mu}}^\bullet(\lambda; \tau)$ similarly.

We will relate $G_{\tilde{\mu}}^\bullet(\lambda; \tau)$ to $\tilde{\mathcal{W}}_{\tilde{\mu}}(q)$ in Theorem 8.2.

3 Relative formal toric Calabi–Yau threefolds

In this section, we will introduce formal toric Calabi–Yau (FTCY) graphs, and construct their associated relative FTCY threefolds.

3.1 Toric Calabi–Yau threefolds

For a smooth toric Calabi–Yau threefold Y , we denote by Y^1 (resp. Y^0) the union of all 1-dimensional (resp. 0-dimensional) $(\mathbb{C}^*)^3$ orbit closures in Y . We assume that

$$Y^1 \text{ is connected and } Y^0 \text{ is nonempty.}$$

Under this condition, we will find a distinguished subtorus $T \subset (\mathbb{C}^*)^3$ and use the T -action to construct a planar trivalent graph Γ_Y . The FTCY graphs that will be defined in Section 3.3 are generalization of such graphs.

We first describe the distinguished subtorus T . We pick a fixed point $p \in Y^0$ and look at the $(\mathbb{C}^*)^3$ action on the tangent space $T_p Y$. Its induced action on the top wedge $\wedge^3 T_p Y$ corresponds to an irreducible character $\alpha_p \in \text{Hom}((\mathbb{C}^*)^3, \mathbb{C}^*)$; by the Calabi–Yau condition and the connectedness of Y^1 , α_p is independent of the choice of p . We define

$$T \stackrel{\text{def}}{=} \text{Ker} \alpha_p \cong (\mathbb{C}^*)^2.$$

We next describe the planar trivalent graph Γ_Y . We let Λ_T be the group of irreducible characters of T , ie,

$$\Lambda_T \stackrel{\text{def}}{=} \text{Hom}(T, \mathbb{C}^*) \cong \mathbb{Z}^{\oplus 2}.$$

We let $T_{\mathbb{R}} \cong U(1)^2$ be the maximal compact subgroup of T ; let $\mathfrak{t}_{\mathbb{R}}$ and $\mathfrak{t}_{\mathbb{R}}^{\vee}$ be its Lie algebra and its dual; let $\mu: Y \rightarrow \mathfrak{t}_{\mathbb{R}}^{\vee}$ be the moment map of the $T_{\mathbb{R}}$ -action on Y . Because of the canonical isomorphism $\mathfrak{t}_{\mathbb{R}}^{\vee} \cong \Lambda_T \otimes_{\mathbb{Z}} \mathbb{R}$, the image of Y^1 under μ forms a *planar trivalent graph* Γ_Y in $\mathbb{Z}^{\oplus 2} \otimes_{\mathbb{Z}} \mathbb{R}$. The graph Γ_Y encodes the information of Y in that its edges and vertices correspond to irreducible components of Y^1 and fixed points Y^0 ; the slope of an edge determines the T -action on the corresponding component of Y^1 .

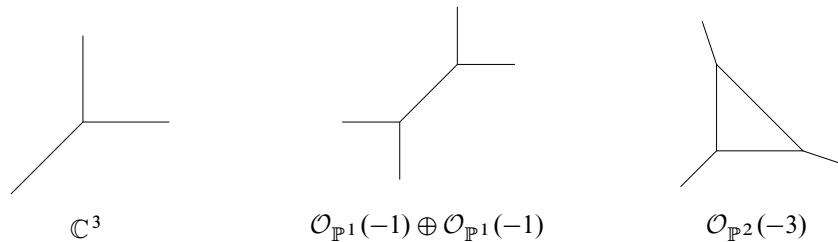

Figure 1: Some examples of planar trivalent graphs

Let \hat{Y} be the formal completion of Y along Y^1 ; \hat{Y} is a smooth formal Calabi–Yau scheme and inherits the T -action on Y . The formal Calabi–Yau scheme \hat{Y} together with the T -action can be reconstructed from the graph Γ_Y (cf (a) in Section 3.2 below). The construction of a relative FTCY threefold from a FTCY graph (given in Section 3.5) can be viewed as generalization of this reconstruction procedure.

3.2 Relative toric Calabi–Yau threefolds

A smooth relative toric Calabi–Yau threefold is a pair (Y, D) , where Y is a smooth toric threefold and D is a possibly disconnected, smooth $(\mathbb{C}^*)^3$ invariant divisor of Y ,

that obeys the relative Calabi–Yau condition:

$$\Lambda^3 \Omega_Y(\log D) \cong \mathcal{O}_Y.$$

A toric Calabi–Yau threefold can be viewed as a relative Calabi–Yau threefold with $D = \emptyset$.

We now describe in details three examples of relative toric Calabi–Yau threefolds and their associated graphs, as they are the building blocks of the definitions and constructions in the rest of Section 3:

- (a) Y is the total space of $\mathcal{O}_{\mathbb{P}^1}(-1+n) \oplus \mathcal{O}_{\mathbb{P}^1}(-1-n)$.
- (b) Y is the total space of $\mathcal{O}_{\mathbb{P}^1}(n) \oplus \mathcal{O}_{\mathbb{P}^1}(-1+n)$; D is its fiber over $q_1 = [1, 0] \in \mathbb{P}^1$.
- (c) Y is the total space of $\mathcal{O}_{\mathbb{P}^1}(n) \oplus \mathcal{O}_{\mathbb{P}^1}(-n)$; D is the union of its fibers over $q_0 = [0, 1]$ and $q_1 = [1, 0]$ in \mathbb{P}^1 .

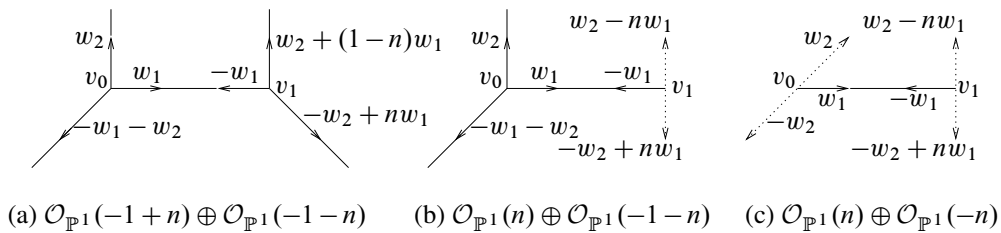

Figure 2: Three basic examples of relative toric Calabi–Yau threefolds

In Figure 2, the edge connecting the two vertices v_0 and v_1 corresponds to the zero section \mathbb{P}^1 ; it is a 1-dimensional $(\mathbb{C}^*)^3$ orbit closure in Y . The vertices v_0 and v_1 correspond to the $(\mathbb{C}^*)^3$ fixed points q_0 and $q_1 \in \mathbb{P}^1$, respectively.

In Case (a), for Y is a toric Calabi–Yau threefold, we may specify a subtorus T as in Section 3.1. The weights of the T -action on the fibers of the bundles $T\mathbb{P}^1$, $\mathcal{O}_{\mathbb{P}^1}(-1+n)$ and $\mathcal{O}_{\mathbb{P}^1}(-1-n)$ at the T -fixed point $q_0 \in \mathbb{P}^1$, respectively, are given by $w_1, w_2, w_3 \in \Lambda_T \cong \mathbb{Z}^{\oplus 2}$; the weights of the same action on the fibers of these bundles at the other fixed point $q_1 \in \mathbb{P}^1$ are given by $-w_1, w_2 + (1-n)w_1$ and $w_3 + (1+n)w_1 = -w_2 + nw_1$, respectively. Here we have $w_1 + w_2 + w_3 = 0$ because T acts on $\wedge^3 T_{q_0} Y$ trivially. Also, from the graph in Figure 2(a) one can read off the T -action on Y and the degrees of the two summands of the normal bundle $N_{\mathbb{P}^1/Y}$. Therefore, Y together with the T -action can be reconstructed from the graph.

Similarly, from the graph in Figure 2(b) and (c), one can reconstruct the pair (Y, D) in (b) and (c) together with the T -action; the weights of the T -action at fixed points can be read off from the graph as follows:

(b)	$T\mathbb{P}^1$	$\mathcal{O}_{\mathbb{P}^1}(n)$	$\mathcal{O}_{\mathbb{P}^1}(-1-n)$	(c)	$T\mathbb{P}^1$	$\mathcal{O}_{\mathbb{P}^1}(n)$	$\mathcal{O}_{\mathbb{P}^1}(-n)$
q_0	w_1	w_2	$w_3 = -w_1 - w_2$	q_0	w_1	w_2	$-w_2$
q_1	$-w_1$	$w_2 - nw_1$	$w_3 + (1+n)w_1 = -w_2 + nw_1$	q_1	$-w_1$	$w_2 - nw_1$	$-w_2 + nw_1$

3.3 FTCY graphs

We now introduce formal toric Calabi–Yau (FTCY) graphs, which are graphs together with local embeddings into the \mathbb{R}^2 endowed with the standard orientation and the integral lattice $\mathbb{Z}^{\oplus 2} \subset \mathbb{R}^2$.

As will be clear later, assigning a slope to an edge depends on the orientation of the edge. For book keeping purpose, we shall associate to each edge two (oppositely) oriented edges; for an oriented edge we can talk about its initial and terminal vertices. To recover the graph, we simply identify the two physically identical but oppositely oriented edges as one (unoriented) edge. This leads to the following definition.

Definition 3.1 (Graphs) A graph Γ consists of a set of *oriented edges* $E^\circ(\Gamma)$, a set of *vertices* $V(\Gamma)$, an *orientation reversing map* $\text{rev}: E^\circ(\Gamma) \rightarrow E^\circ(\Gamma)$, an *initial vertex map* $\mathfrak{v}_0: E^\circ(\Gamma) \rightarrow V(\Gamma)$ and a *terminal vertex map* $\mathfrak{v}_1: E^\circ(\Gamma) \rightarrow V(\Gamma)$. Together they satisfy the property that rev is a fixed point free involution; that both \mathfrak{v}_0 and \mathfrak{v}_1 are surjective and $\mathfrak{v}_1 = \mathfrak{v}_0 \circ \text{rev}$. We say Γ is *weakly trivalent* if $|\mathfrak{v}_0^{-1}(v)| \leq 3$ for $v \in V(\Gamma)$.

For simplicity, we will abbreviate $\text{rev}(e)$ to $-e$. Then the equivalence classes $E(\Gamma) = E^\circ(\Gamma)/\{\pm 1\}$ is the set of edges of Γ in the ordinary sense. In case Γ is weakly trivalent, we shall denote by $V_1(\Gamma)$, $V_2(\Gamma)$ and $V_3(\Gamma)$ the sets of univalent, bivalent, and trivalent vertices of Γ ; we shall also define

$$E^\dagger(\Gamma) = \{e \in E^\circ(\Gamma) \mid \mathfrak{v}_1(e) \in V_1(\Gamma) \cup V_2(\Gamma)\};$$

it is the set of oriented edges whose terminal edges are not trivalent. Finally, we fix a standard basis $\{u_1, u_2\}$ of $\mathbb{Z}^{\oplus 2}$ such that the ordered basis (u_1, u_2) determines the orientation on \mathbb{R}^2 .

Definition 3.2 (FTCY graphs) A *formal toric Calabi–Yau (FTCY) graph* is a weakly trivalent graph Γ together with a *position map*

$$\mathfrak{p}: E^\circ(\Gamma) \longrightarrow \mathbb{Z}^{\oplus 2} - \{0\}$$

and a framing map

$$f: E^f(\Gamma) \longrightarrow \mathbb{Z}^{\oplus 2} - \{0\},$$

such that (see Figure 3)

(T1) p is antisymmetric: $p(-e) = -p(e)$.

(T2) p and f are balanced:

- For a bivalent vertex $v \in V_2(\Gamma)$ with $v_1^{-1}(v) = \{e_1, e_2\}$, $p(e_1) + p(e_2) = 0$ and $f(e_1) + f(e_2) = 0$.
- For a trivalent $v \in V_3(\Gamma)$ with $v_0^{-1}(v) = \{e_1, e_2, e_3\}$ and $p(e_1) + p(e_2) + p(e_3) = 0$.

(T3) p and f are primitive:

- For a trivalent vertex $v \in V_3(\Gamma)$ with $v_0^{-1}(v) = \{e_1, e_2, e_3\}$, any two vectors in $\{p(e_1), p(e_2), p(e_3)\}$ form an integral basis of $\mathbb{Z}^{\oplus 2}$
- For $e \in E^f(\Gamma)$, $p(e) \wedge f(e) = u_1 \wedge u_2$.

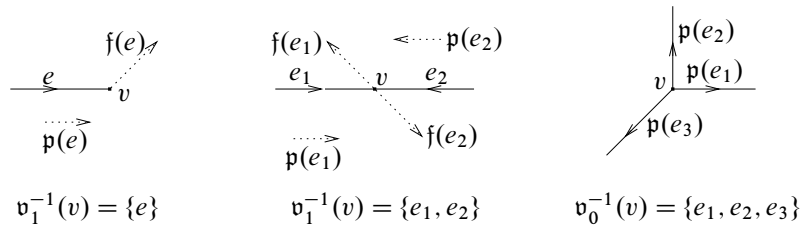

Figure 3: The position map p and the framing map f

We say Γ is a *regular* FTCY graph if it has no bivalent vertex.

To each edge e in a FTCY graph we shall construct a relative Calabi–Yau threefold (Y^e, D^e) . Intuitively, such Y^e resembles the examples (a), (b) or (c) in Figure 2 (if we add vectors $\{-f(e) \mid v_1(e) \in V_1(E)\}$). The threefold Y^e will be the total space of the direct sum of two line bundles over \mathbb{P}^1 , one L^e and the other L^{-e} . We define the weights $l_0(e)$ and $l_1(e)$ of the T -action on $L_{q_0}^e$ and $L_{q_1}^e$ as follows: like in Figure 2(a), (b) or in (c), if we arrange so that $p(e) = w_1$ is pointing to the right, and v_0 and v_1 are the initial and the terminal vertices of e , then we define $l_0(e)$ and $l_1(e)$ be that given by the upward vectors at v_0 and v_1 .

Definition 3.3 Let Γ be an FTCY graph. We define $l_0, l_1: E^o(\Gamma) \longrightarrow \mathbb{Z}^{\oplus 2}$ as follows:

$$l_0(e) = \begin{cases} -f(-e), & v_0(e) \notin V_3(\Gamma), \\ p(e_{01}), & v_0(e) \in V_3(\Gamma). \end{cases} \quad l_1(e) = \begin{cases} f(e), & v_1(e) \notin V_3(\Gamma), \\ p(e_{11}), & v_1(e) \in V_3(\Gamma). \end{cases}$$

Here e_{i1} is the unique oriented edge such that $v_0(e_{i1}) = v_i(e)$ and $p(e) \wedge p(e_{i1}) = u_1 \wedge u_2$.

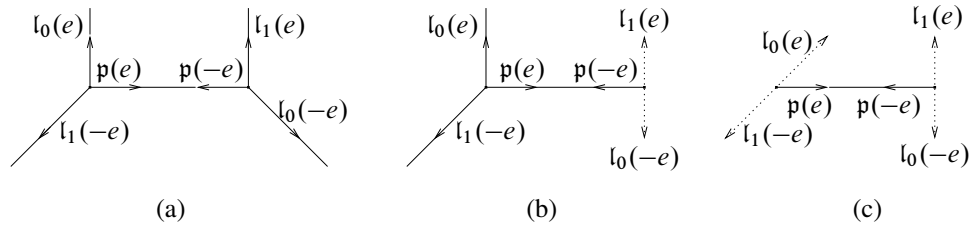

Figure 4: $l_0, l_1: E^\circ(\Gamma) \rightarrow \mathbb{Z}^{\oplus 2}$. (a) $v_0(e), v_1(e) \in V_3(\Gamma)$ (b) $v_0(e) \in V_3(\Gamma), v_1(e) \in V_1(\Gamma) \cup V_2(\Gamma)$ (c) $v_0(e), v_1(e) \in V_1(\Gamma) \cup V_2(\Gamma)$

The degree of the line bundle L^e determines an integer n^e :

$$n^e = \begin{cases} \deg L^e + 1, & v_1 \in V_3(\Gamma), \\ \deg L^e, & v_1 \notin V_3(\Gamma). \end{cases}$$

This motivates the following definition.

Definition 3.4 We define $\vec{n}: E^\circ(\Gamma) \rightarrow \mathbb{Z}$ by

$$l_1(e) - l_0(e) = \begin{cases} (1 - \vec{n}(e))p(e), & v_1(e) \in V_3(\Gamma), \\ -\vec{n}(e)p(e), & v_1(e) \notin V_3(\Gamma). \end{cases}$$

We write n^e for $\vec{n}(e)$.

Note that $n^{-e} = -n^e$.

3.4 Operations on FTCY graphs

In this subsection, we define four operations on FTCY graphs: smoothing, degeneration, normalization, and gluing. These operations extend natural operations on toric Calabi–Yau threefolds.

The first operation is the smoothing of a bivalent vertex $v \in V_2(\Gamma)$. This operation eliminates the vertex v and combines the two edges attached to v .

Definition 3.5 (Smoothing) The *smoothing* of Γ along a bivalent vertex $v \in V_2(\Gamma)$ is a graph Γ_v that has vertices $V(\Gamma) - \{v\}$, oriented edges $E^\circ(\Gamma) / \sim$ with the equivalence $\pm e_1 \sim \mp e_2$ for $\{e_1, e_2\} = v_1^{-1}(v)$. The maps v_0, v_1, p and f descend to corresponding maps on Γ_v , making it a FTCY graph. (See Figure 5: Γ_3 is the smoothing of Γ_2 along v .)

The reverse of the above construction is called a degeneration.

Definition 3.6 (Degeneration) Let Γ be a FTCY graph and let $e \in E^0(\Gamma)$ be an edge. We pick a lattice point $f_0 \in \mathbb{Z}^{\oplus 2}$ so that $p(e) \wedge f_0 = u_1 \wedge u_2$. The *degeneration* of Γ at e with framing f_0 is a graph Γ_{e, f_0} whose edges are $(E^0(\Gamma) - \{\pm e\}) \cup \{\pm e_1, \pm e_2\}$ and whose vertices are $V(\Gamma) \cup \{v_0\}$; its initial vertices \tilde{v}_0 , terminal vertices \tilde{v}_1 , position map \tilde{p} and framing map \tilde{f} are identical to those of Γ except

$$\begin{aligned} \tilde{v}_0(e_1) &= v_0(e), \quad \tilde{v}_1(e_1) = \tilde{v}_1(e_2) = v_0, \quad \tilde{v}_0(e_2) = v_1(e), \\ \tilde{p}(e_1) &= -\tilde{p}(e_2) = p(e), \quad \tilde{f}(e_1) = \tilde{f}(e_2) = f_0. \end{aligned}$$

(See Figure 5: Γ_2 is the degeneration of Γ_3 at e with framing f_0 .)

The normalization is to separate a graph along a bivalent vertex and the gluing is its inverse.

Definition 3.7 (Normalization) Let Γ be a FTCY graph and let $v \in V_2(\Gamma)$ be a bivalent vertex. The *normalization* of Γ at v is a graph Γ^v whose edges are the same as that of Γ and whose vertices are $(V(\Gamma) - \{v\}) \cup \{v_1, v_2\}$; its associated maps \tilde{v}_0 , \tilde{v}_1 , \tilde{p} and \tilde{f} are identical to that of Γ except for $\{e_1, e_2\} = v_1^{-1}(v)$, $\tilde{v}_1(e_1) = v_1$ and $\tilde{v}_1(e_2) = v_2$. (See Figure 5: Γ_1 is the normalization of Γ_2 at v .)

Definition 3.8 (Gluing) Let Γ be a FTCY graph and let $v_1, v_2 \in V_1(\Gamma)$ be two univalent vertices of Γ . Let $f_i = f(e_i)$, where $\{e_i\} = v_1^{-1}(v_i)$. Suppose $p(e_1) = -p(e_2)$ and $f_1 = -f_2$. We then identify v_1 and v_2 to form a single vertex, and keep the framing $f(e_i) = f_i$. The resulting graph Γ^{v_1, v_2} is called the *gluing* of Γ at v_1 and v_2 . (See Figure 5: Γ_2 is the gluing of Γ_1 at v_1 and v_2 .)

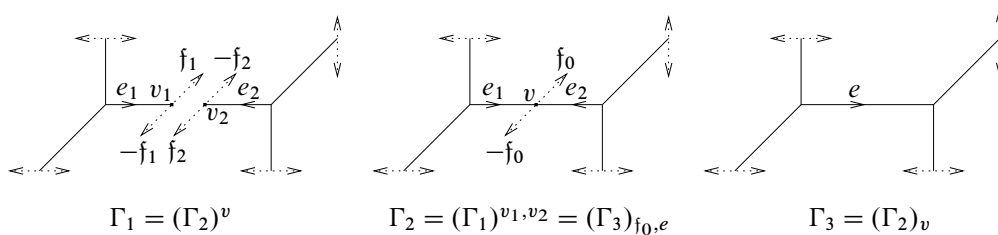

Figure 5: Operations on FTCY graphs

It is straightforward to generalize smoothing and normalization to subset A of $V_2(\Gamma)$. Given $A \subset V_2(\Gamma)$, let Γ_A denote the smoothing of Γ along A , and let Γ^A denote the

normalization of Γ along A . There are surjective maps

$$\pi_A: E(\Gamma) \rightarrow E(\Gamma_A), \quad \pi^A: V(\Gamma^A) \rightarrow V(\Gamma).$$

3.5 Relative FTCY threefolds

In this subsection we will introduce relative formal toric Calabi–Yau (FTCY) threefolds.

Given a FTCY graph Γ , we will construct a pair $\hat{Y}^{\text{rel}} = (\hat{Y}, \hat{D})$, where \hat{Y} is a formal threefold, possibly with normal crossing singularities, $\hat{D} \subset \hat{Y}$ is a relative divisor, so that $\hat{Y}^{\text{rel}} = (\hat{Y}, \hat{D})$ is a formal relative Calabi–Yau threefold:

$$\wedge^3 \Omega_{\hat{Y}}(\log \hat{D}) \cong \mathcal{O}_{\hat{Y}}.$$

The pair (\hat{Y}, \hat{D}) admits a T -action so that the action on $\wedge^3 T_p \hat{Y}$ is trivial for any fixed point p .

To motivate our construction to be followed momentarily, we remark that for Y a smooth toric Calabi–Yau threefold, with Y^1 the union of closures of 1-dimensional orbits, the formal completion \hat{Y} of Y along Y^1 will be examples of our formal toric Calabi–Yau threefolds to be introduced. Note that the set of closed points of \hat{Y} is Y^1 , which is a union of \mathbb{P}^1 or \mathbb{A}^1 . However, due to the formal scheme structure of \hat{Y} along Y^1 , $\dim \hat{Y} = 3$.

The pair (\hat{Y}, \hat{D}) has similar properties. The set of closed points of \hat{Y} is a union of \mathbb{P}^1 's, each associated to an edge of Γ . Two \mathbb{P}^1 intersect exactly when their associated edges share a common vertex. The normal bundle to each \mathbb{P}^1 in \hat{Y} and the T -action on \hat{Y} are dictated by the data encoded in the graph Γ . A T -invariant divisor $\hat{L} \subset \hat{D}$ will be specified according to the data of framings.

In the following construction, we will use the notation introduced in Section 3.3.

3.5.1 Edges Let $e \in E^0(\Gamma)$ with v_0 and v_1 its initial and terminal vertices. We first define $\Sigma(e) = \mathbb{P}^1$ with homogeneous coordinates $[x_0^e, 1]$. By viewing $\mathfrak{p}(e)$ as an element in $\Lambda_T = \text{Hom}(T, \mathbb{C}^*)$, we define a T -action on $\Sigma(e)$ by

$$t \cdot [x_0^e, 1] = [\mathfrak{p}(e)(t)x_0^e, 1], \quad t \in T.$$

We denote the two fixed points by $q_0 = [0, 1]$ and $q_1 = [\infty, 1] = [1, 0]$. Next we let $L^e \rightarrow \Sigma(e)$ be the line bundle of degree

$$\deg L^e = \begin{cases} n^e - 1, & v_1 \in V_3(\Gamma), \\ n^e, & v_1 \notin V_3(\Gamma), \end{cases}$$

where $n^e = \vec{n}(e)$ is defined in Definition 3.4. We then assign the T -actions on $L_{q_0}^e$ and $L_{q_1}^e$ to be $\iota_0(e)$ and $\iota_1(e)$, respectively.

For the opposite edge $-e$, we have similarly defined $\Sigma(-e) \cong \mathbb{P}^1$ and the T -line bundle L^{-e} on $\Sigma(-e)$. Because of our construction, the isomorphism $\iota_e: \Sigma(e) \cong \Sigma(-e)$ induced by $x_0^e = (x_0^{-e})^{-1}$ is a T -isomorphism. Under this isomorphism, the line bundles L^e and L^{-e} are line bundles over $\Sigma(e)$ and $\Sigma(-e)$.

With the line bundles L^e and L^{-e} on $\Sigma(e)$, we define $\hat{Y}(e)$ to be the formal completion of the total space of $L^e \oplus L^{-e}$ along its zero section. The T -actions on L^e and L^{-e} induce a T -action on $\hat{Y}(e)$.

Clearly, the isomorphism $\iota_e: \Sigma(e) \cong \Sigma(-e)$ and the isomorphism $\iota_e^* L^{\pm e} \cong L^{\pm e}$ extend to a tautological isomorphism

$$\hat{Y}(e) \cong \hat{Y}(-e).$$

Let $p: \hat{Y}(e) \rightarrow \Sigma(e) = \mathbb{P}^1$ be the projection and let $c = \#(\{v_0, v_1\} \cap V_3(\Gamma)) - 2$. It is clear that

$$(3-1) \quad \wedge^3 \Omega_{\hat{Y}(e)} \cong p^* \mathcal{O}_{\mathbb{P}^1}(c).$$

For the construction we are about to perform, it will be handy to have a local coordinate of $\Sigma(e)$ at q_0 . Derived from the homogeneous coordinate $[x_0^e, 1]$ of $\Sigma(e)$, the x_0^e forms an affine coordinate of $\Sigma(e)^0 = \Sigma(e) - q_1 = \mathbb{A}^1$. We then fix T -equivariant trivializations

$$L^e|_{\Sigma(e)^0} \cong \text{Spec } \mathbb{C}[x_0^e, x_1^e] \quad \text{and} \quad L^{-e}|_{\Sigma(e)^0} \cong \text{Spec } \mathbb{C}[x_0^e, x_{-1}^e].$$

3.5.2 Near trivalent vertices Let $v \in V_3(\Gamma)$ be a trivalent vertex; let $\mathfrak{v}_0^{-1}(v) = \{e_1, e_2, e_3\}$ be so indexed that $\mathfrak{p}(e_1), \mathfrak{p}(e_2), \mathfrak{p}(e_3)$ is in counter-clockwise order. We first show how to construct a neighborhood of v in the intended FTCY.

For this purpose, we form the total space (denoted by $Y(e_k)^0$):

$$(3-2) \quad Y(e_k)^0 = (L^{e_k} \oplus L^{-e_k})|_{\Sigma(e_k)^0} = \text{Spec } \mathbb{C}[x_0^{e_k}, x_1^{e_k}, x_{-1}^{e_k}],$$

using the explicit coordinates introduced in (3-2). We define gluing homomorphism ψ_{e_k} be

$$\psi_{e_k}: \mathbb{C}[y_1, y_2, y_3] \longrightarrow \mathbb{C}[x_0^{e_k}, x_1^{e_k}, x_{-1}^{e_k}], \quad y_{j+k(3)} \mapsto x_j^{e_k}.$$

(Here $j+k(3)$ is $j+k$ modulo 3.) Note that under this arrangement, the directions $T_{q_0}\Sigma(e_1)^0$, $L^{-e_2}|_{q_0}$ and $L^{e_3}|_{q_0}$ are all mapped to the same direction.

We then define $\hat{Y}(v)$ be the formal completion of $\text{Spec } \mathbb{C}[y_1, y_2, y_3]$ along the union of the three y -axes. Using ψ_{e_k} , $\hat{Y}(v)$ is also the formal completion of $Y(e_k)^0$ along the three axes, and under these identification, the y_k -axis is exactly the line $\Sigma(e_k)^0$.

3.5.3 Near bivalent and univalent vertices Next we look at a bivalent vertex v . Let e_1 and e_2 be the two edges so that $\{e_1, e_2\} = \mathfrak{v}_0^{-1}(v)$. Let $\Sigma(e_k)^0$ and $Y(e_k)^0$ be as before. We then form the ring $\mathbb{C}[y_1, y_2, u_1, u_2]/(y_1 y_2)$ and the gluing homomorphisms

$$\psi_{e_k}: \mathbb{C}[y_1, y_2, u_1, u_2]/(y_1 y_2) \longrightarrow \mathbb{C}[x_0^{e_k}, x_1^{e_k}, x_{-1}^{e_k}]$$

by the rule: the homomorphism ψ_{e_1} maps $u_1 \mapsto x_1^{e_1}$, $u_2 \mapsto x_{-1}^{e_1}$, $y_1 \mapsto x_0^{e_1}$ and $y_2 \mapsto 0$; the homomorphism ψ_{e_2} maps $u_1 \mapsto x_{-1}^{e_2}$, $u_2 \mapsto x_1^{e_2}$, $y_1 \mapsto 0$ and $y_2 \mapsto x_0^{e_2}$.

We define $\widehat{Y}(v)$ to be the formal completion of $\text{Spec } \mathbb{C}[y_1, y_2, u_1, u_2]/(y_1 y_2)$ along the union of the y_1 and y_2 axes; it is singular along a divisor $\widehat{D}^v \cong \text{Spec } \mathbb{C}[[u_1, u_2]]$.

Lastly, consider $v \in V_1(\Gamma)$ with $e = \mathfrak{v}_0^{-1}(v)$. We define $Y(e)^0 = \text{Spec } \mathbb{C}[x_0^e, x_1^e, x_{-1}^e]$; we define $\widehat{Y}(v)$ to be the formal completion of $Y(e)^0$ along the x_0^e axis; we define \widehat{D}^v to be the divisor defined by $x_0^e = 0$, and consider it as part of the relative divisor of the formal Calabi–Yau scheme \widehat{Y}^{rel} we are constructing. We also introduce another divisor \widehat{L}^v in \widehat{D}^v :

$$\widehat{L}^v = (x_{-1}^e = x_0^e = 0) \subset \widehat{D}^v = (x_0^e = 0).$$

3.5.4 Gluing the pieces At last, we will glue all $\widehat{Y}(v)$ to form a formal scheme \widehat{Y} . To do this, we first form the disjoint union

$$(3-3) \quad \coprod_{v \in V(\Gamma)} \widehat{Y}(v).$$

To glue, we need to introduce equivalence relations. Let e be an edge and let v_1 be its initial vertex and v_2 be its terminal vertex. By our construction of $\widehat{Y}(v_1)$, the scheme

$$\widehat{Y}(e)_0 = \widehat{Y}(-e)_0 = \text{Spec } \mathbb{C}[x_0^e, (x_0^e)^{-1}][[x_1^e, x_{-1}^e]]$$

is canonically an open subscheme of $\widehat{Y}(v_1)$. Note that as a set it is the part

$$\text{Spec } \mathbb{C}[x_0^e, (x_0^e)^{-1}] \subset \widehat{Y}(v_1).$$

Similarly, since v_2 is the initial vertex of $-e$, it is also an open subset of $\widehat{Y}(v_2)$. Hence we can use the open embeddings

$$\widehat{Y}(e)_0 \subset \widehat{Y}(v_1) \quad \text{and} \quad \widehat{Y}(e)_0 \subset \widehat{Y}(v_2)$$

to glue $\widehat{Y}(v_1)$ and $\widehat{Y}(v_2)$ along $\widehat{Y}(e)_0$.

By gluing $\widehat{Y}(v_1)$ and $\widehat{Y}(v_2)$ in (3-3) for all pairs of adjacent vertices in Γ we obtain a formal threefold \widehat{Y} . The T -actions on $\widehat{Y}(v)$'s descend to a T -action on \widehat{Y} . Finally, for each univalent vertex v , we let $\widehat{D}^v \subset \widehat{Y}(v)$ be the divisor defined in Section 3.5.3. The (disjoint) union of all such \widehat{D}^v form a divisor \widehat{D} that is the relative divisor of \widehat{Y} .

Since \hat{D} is invariant under T , the pair $\hat{Y}^{\text{rel}} = (\hat{Y}, \hat{D})$ is a T -equivariant formal scheme. Because of (3-1), we have

$$\wedge^3 \Omega_{\hat{Y}}(\log \hat{D}) \cong \mathcal{O}_{\hat{Y}};$$

hence $\hat{Y}^{\text{rel}} = (\hat{Y}, \hat{D})$ is a formal toric Calabi–Yau scheme.

Following the construction, the scheme \hat{Y} has only normal crossing singularities along \hat{D}^v for all bivalent vertices v :

$$\hat{Y}_{\text{sing}} = \coprod_{v \in V_2(\Gamma)} \hat{D}^v.$$

Therefore \hat{Y} is smooth when $V_2(\Gamma)$ is empty. The relative divisor \hat{D} is the disjoint union of smooth divisors \hat{D}^v indexed by univalent vertices v :

$$(3-4) \quad \hat{D} = \coprod_{v \in V_1(\Gamma)} \hat{D}^v.$$

Within each divisor \hat{D}^v in (3-4) there is a divisor $\hat{L}^v \subset \hat{D}^v$ defined as in Section 3.5.3.

From the construction, the scheme \hat{Y}^{rel} depends on the graph Γ . Often we will omit the Γ in the notation if there is no confusion. However, in case we need to emphasize such dependence, we shall use $\hat{Y}_{\Gamma}^{\text{rel}}$ in place of \hat{Y}^{rel} .

For later convenience, we introduce some notation. Let \bar{e} be the equivalence class $\{e, -e\}$ in $E(\Gamma)$; let $C^{\bar{e}}$ be the projective line $\Sigma(e) = \Sigma(-e) \subset \hat{Y}$. For $v \in V_1(\Gamma)$, we let z^v be the closed point in \hat{D}^v that is the T -invariant point q_0 in $\Sigma(e)^0$ for $v_0(e) = v$.

4 Definition of formal relative Gromov–Witten invariants

In this section, we will define relative Gromov–Witten invariants of relative FTCY threefolds; the case of indecomposable relative FTCY threefolds gives the mathematical definition of topological vertex.

4.1 Moduli spaces of relative stable morphisms

Let Γ be an FTCY graph and let $\hat{Y}^{\text{rel}} = (\hat{Y}, \hat{D})$ be its associated scheme. We first clarify the degrees and the ramification patterns of relative stable morphisms to \hat{Y}^{rel} .

Definition 4.1 (Effective class) Let Γ be a FTCY graph. An *effective class* of Γ is a pair of functions $\vec{d}: E(\Gamma) \rightarrow \mathbb{Z}_{\geq 0}$ and $\vec{\mu}: V_1(\Gamma) \rightarrow \mathcal{P}$ that satisfy

- (1) $|\vec{\mu}(v)| = \vec{d}(\bar{e})$ if $v \in V_1(\Gamma)$ and $\mathfrak{v}_1(e) = v$;
- (2) $\vec{d}(\bar{e}_1) = \vec{d}(\bar{e}_2)$ if $v \in V_2(\Gamma)$ and $\mathfrak{v}_0^{-1}(v) = \{e_1, e_2\}$.

We write μ^v for $\vec{\mu}(v)$, and $d^{\bar{e}}$ for $\vec{d}(\bar{e})$.

To show that an effective class does characterize a relative stable morphism, a quick review of its definition is in order. An ordinary relative morphism u to (\hat{Y}, \hat{D}) consists of

- a possibly disconnected nodal curve X ;
- distinct smooth points $\{q_j^v \mid v \in V_1(\Gamma), 1 \leq j \leq \ell(\mu^v)\}$ in X such that each connected component of X contains at least one of these points;
- a morphism $u: X \rightarrow \hat{Y}$

satisfying the properties:

- For each $v \in V_1(\Gamma)$, $u^{-1}(\hat{D}^v) = \sum_{j=1}^{\ell(\mu^v)} \mu_j^v q_j^v$ for some positive integers μ_j^v ;
- u is *predeformable* along the singular loci $\coprod_{v \in V_2(\Gamma)} \hat{D}^v$ of \hat{Y}^{rel} , i.e, if $v \in V_2(\Gamma)$ and $\mathfrak{v}_0^{-1}(v) = \{e_1, e_2\}$, then $u^{-1}(\hat{D}^v)$ consists of nodes of X , and for each $y \in u^{-1}(\hat{D}^v)$, $u|_{u^{-1}(\Sigma(e_1))}$ and $u|_{u^{-1}(\Sigma(e_2))}$ have the same contact order to \hat{D}^v at y ;
- u coupled with the marked points q_i^v is a stable morphism in the ordinary sense.

Unless otherwise specified, all the stable morphisms in this paper are with not necessarily connected domains.

Since

$$H_2(\hat{Y}; \mathbb{Z}) = \bigoplus_{\bar{e} \in E(\Gamma)} \mathbb{Z}[C^{\bar{e}}],$$

the morphism u defines a map $\vec{d}: E(\Gamma) \rightarrow \mathbb{Z}$ via

$$(4-1) \quad u_*([X]) = \sum_{\bar{e} \in E(\Gamma)} \vec{d}(\bar{e})[C^{\bar{e}}].$$

The integers μ_j^v form a partition

$$\mu^v = (\mu_1^v, \dots, \mu_{\ell(\mu^v)}^v)$$

and the map $\vec{\mu}: V_1(\Gamma) \rightarrow \mathcal{P}$ is

$$\vec{\mu}(v) = \mu^v.$$

With this definition, the requirement (1) in Definition 4.1 follows from (4-1) and (2) since u is predeformable.

To define relative stable morphisms to \hat{Y}^{rel} , we need to work with the expanded schemes of \hat{Y}^{rel} introduced by the first author [19]. In the case studied, they are the associated formal schemes of the expanded graphs of Γ .

Definition 4.2 Let Γ be a FTCY graph. A *flat chain of length n* in Γ is a subgraph $\check{\Gamma} \subset \Gamma$ that has n edges $\pm e_1, \dots, \pm e_n$, $n + 1$ univalent or bivalent vertices v_0, \dots, v_n with identical framings \mathfrak{f} (up to sign) so that

$$\mathfrak{v}_0(e_1) = v_0; \quad \mathfrak{v}_1(e_i) = \mathfrak{v}_0(e_{i+1}) = v_i, \quad i = 1, \dots, n - 1; \quad \mathfrak{v}_1(e_n) = v_n,$$

and that all $\mathfrak{p}(e_i)$ are identical.

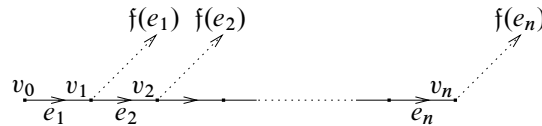

Figure 6: A flat chain of length n

Definition 4.3 A *contraction* of a FTCY graph Γ along a flat chain $\check{\Gamma} \subset \Gamma$ is the graph after eliminating all edges and bivalent vertices of $\check{\Gamma}$ from Γ , identifying the univalent vertices of $\check{\Gamma}$ while keeping their framings unchanged.

Given a FTCY graph Γ and a function

$$\mathbf{m}: V_1(\Gamma) \cup V_2(\Gamma) \longrightarrow \mathbb{Z}_{\geq 0},$$

the expanded graph $\Gamma_{\mathbf{m}}$ is obtained by replacing each $v \in V_1(\Gamma) \cup V_2(\Gamma)$ by a flat chain $\check{\Gamma}_{m^v}^v$ of length $m^v = \mathbf{m}(v)$ with framings $\pm \mathfrak{f}(e)$, where $\mathfrak{v}_1(e) = v$. In particular $\Gamma_{\mathbf{0}} = \Gamma$ for the function $\mathbf{0}(v) = 0$ for all $v \in V_1(\Gamma) \cup V_2(\Gamma)$. The original graph Γ can be recovered by contracting $\Gamma_{\mathbf{m}}$ along the flat chains

$$\{\check{\Gamma}_{m^v}^v \mid v \in V_1(\Gamma) \cup V_2(\Gamma)\}.$$

We now study their associated Calabi–Yau schemes. We denote by (\hat{Y}, \hat{D}) the associated Calabi–Yau scheme of Γ and by $(\hat{Y}_{\mathbf{m}}, \hat{D}_{\mathbf{m}})$ that of $\Gamma_{\mathbf{m}}$. We recover the original scheme \hat{Y} by shrinking the irreducible components of $\hat{Y}_{\mathbf{m}}$ associated to the flat chains that are contracted. This way we obtain a projection

$$\pi_{\mathbf{m}}: \hat{Y}_{\mathbf{m}} \longrightarrow \hat{Y}.$$

We define a relative automorphism of $\widehat{Y}_{\mathbf{m}}$ to be an automorphism of $\widehat{Y}_{\mathbf{m}}$ that is also a \widehat{Y} -morphism; an automorphism of a relative morphism $u: X \rightarrow (\widehat{Y}_{\mathbf{m}}, \widehat{D}_{\mathbf{m}})$ is a pair of a relative automorphism σ of $\widehat{Y}_{\mathbf{m}}$ and an automorphism h of X so that

$$u \circ h = \sigma \circ u.$$

Definition 4.4 A relative morphism to $\widehat{Y}_{\Gamma}^{\text{rel}}$ is an ordinary relative morphism to $(\widehat{Y}_{\mathbf{m}}, \widehat{D}_{\mathbf{m}})$ for some \mathbf{m} ; it is *stable* if its automorphism group is finite.

The contraction $c_{\mathbf{m}}: \Gamma_{\mathbf{m}} \rightarrow \Gamma$ induces bijections (which we also call $c_{\mathbf{m}}$):

$$V_1(\Gamma_{\mathbf{m}}) \longrightarrow V_1(\Gamma), \quad E(\Gamma_{\mathbf{m}}) - \left(\coprod_{v \in V_1(\Gamma) \cup V_2(\Gamma)} E(\check{\Gamma}_{\mathbf{m}^v}^v) \right) \longrightarrow E(\Gamma).$$

Definition 4.5 Given an effective class $(\vec{d}, \vec{\mu})$ of Γ , we define an effective class $(\vec{d}_{\mathbf{m}}, \vec{\mu}_{\mathbf{m}})$ of $\Gamma_{\mathbf{m}}$ as follows. Define $\vec{\mu}_{\mathbf{m}}(v) = \vec{\mu}(c_{\mathbf{m}}(e))$ for $v \in V_1(\Gamma_{\mathbf{m}})$, and define

$$\vec{d}_{\mathbf{m}}(\bar{e}) = \begin{cases} \vec{d}(\bar{e}_1), & \bar{e} \in E(\check{\Gamma}_{\mathbf{m}^v}^v), \nu_0(e_1) = v, \\ \vec{d}(c_{\mathbf{m}}(\bar{e})), & \text{otherwise,} \end{cases}$$

for $\bar{e} \in E(\Gamma_{\mathbf{m}})$.

We fix a FTCY graph Γ , an effective class $(\vec{d}, \vec{\mu})$ of Γ , and an even integer χ . We then form the moduli space $\overline{\mathcal{M}}_{\chi, \vec{d}, \vec{\mu}}^{\bullet}(\widehat{Y}^{\text{rel}})$ of all stable relative morphisms u to \widehat{Y}^{rel} that satisfy

- $\chi(\mathcal{O}_X) = \chi/2$, where X is the domain curve of u ;
- the associated effective class of u is $(\vec{d}_{\mathbf{m}}, \vec{\mu}_{\mathbf{m}})$ if the target of the morphism is $(\widehat{Y}_{\mathbf{m}}, \widehat{D}_{\mathbf{m}})$.

Since \widehat{Y} is a formal Calabi–Yau threefold with possibly normal crossing singularity and smooth singular loci, the moduli space $\overline{\mathcal{M}}_{\chi, \vec{d}, \vec{\mu}}^{\bullet}(\widehat{Y}^{\text{rel}})$ is a formal Deligne–Mumford stack with a perfect obstruction theory [19; 20].

Lemma 4.6 The virtual dimension of $\overline{\mathcal{M}}_{\chi, \vec{d}, \vec{\mu}}^{\bullet}(\widehat{Y}^{\text{rel}})$ is $\sum_{v \in V_1(\Gamma)} \ell(\mu^v)$.

Proof The proof is straightforward and will be omitted. □

4.2 Equivariant degeneration

We let $\mathfrak{p} \in \Lambda_T = \text{Hom}(T, \mathbb{C}^*)$ and let T act on $\mathbb{P}^1 \times \mathbb{A}^1$ by

$$t \cdot ([x_0, x_1], s) = ([\mathfrak{p}(t)x_0, x_1], s).$$

Let \mathfrak{Y} be the blowup of $\mathbb{P}^1 \times \mathbb{A}^1$ at $([0, 1], 0)$. The T -action on $\mathbb{P}^1 \times \mathbb{A}^1$ can be lifted to \mathfrak{Y} making the projection $\mathfrak{Y} \rightarrow \mathbb{P}^1 \times \mathbb{A}^1$ T -equivariant. Composed with the projection $\mathbb{P}^1 \times \mathbb{A}^1 \rightarrow \mathbb{A}^1$, the morphism

$$\mathfrak{Y} \longrightarrow \mathbb{A}^1$$

becomes a T -equivariant family of curves whose fibers over $s \neq 0$ are \mathbb{P}^1 and whose central fiber $\mathfrak{Y}_0 \cong \mathbb{P}^1 \sqcup \mathbb{P}^1$.

The above construction can be generalized to many nodes cases. Let Γ be a FTCY graph and let

$$V_2(\Gamma) = \{v_1, \dots, v_n\}$$

be a complete list of bivalent vertices. Then we have a T -equivariant family

$$(\widehat{\mathcal{Y}}, \widehat{\mathcal{D}}) \rightarrow \mathbb{A}^n$$

that has the property that for any subset $J \subset \{1, \dots, n\}$, the fiber of $(\widehat{\mathcal{Y}}, \widehat{\mathcal{D}})$ over any closed point in the set

$$\mathbb{A}_J^n = \{(s_1, \dots, s_n) \in \mathbb{A}^n \mid s_j = 0 \text{ if and only if } j \notin J\}$$

is the scheme $\widehat{Y}_{\Gamma_J}^{\text{rel}}$, where Γ_J is the smoothing of Γ along the bivalent vertices $\{v_j \mid j \in J\}$. In particular,

$$\mathbb{A}_{\emptyset}^n = \{(0, \dots, 0)\}, \quad \Gamma_{\emptyset} = \Gamma.$$

The family is T -equivariant with T acts trivially on \mathbb{A}^n and on each fiber as described in Section 3.

By the construction in [20], there is a T -equivariant family

$$\mathcal{M}_{\chi, \vec{d}, \vec{\mu}}^{\bullet}(\widehat{\mathcal{Y}}) \rightarrow \mathbb{A}^n$$

such that $\mathcal{M}_{\chi, \vec{d}, \vec{\mu}}^{\bullet}(\widehat{\mathcal{Y}})_s = \mathcal{M}_{\chi, \vec{d}, \vec{\mu}}^{\bullet}(\widehat{\mathcal{Y}}_s)$ for $s \in \mathbb{A}^n$. In particular,

$$\mathcal{M}_{\chi, \vec{d}, \vec{\mu}}^{\bullet}(\widehat{\mathcal{Y}})_0 = \overline{\mathcal{M}}_{\chi, \vec{d}, \vec{\mu}}^{\bullet}(\widehat{Y}^{\text{rel}}).$$

The total space $\mathcal{M}_{\chi, \vec{d}, \vec{\mu}}^{\bullet}(\hat{\mathcal{Y}})$ is a formal Deligne–Mumford stack with a perfect obstruction theory $[\mathbf{T}^1 \rightarrow \mathbf{T}^2]$ of virtual dimension

$$\sum_{v \in V_1(\Gamma)} \ell(\mu^v) + |V_2(\Gamma)|.$$

For each $v \in V_2(\Gamma)$ there is a line bundle \mathbf{L}^v on $\mathcal{M}_{\chi, \vec{d}, \vec{\mu}}^{\bullet}(\hat{\mathcal{Y}})$ with a section

$$s^v: \mathcal{M}_{\chi, \vec{d}, \vec{\mu}}^{\bullet}(\hat{\mathcal{Y}}) \rightarrow \mathbf{L}^v$$

such that

$$\bar{\mathcal{M}}_{\chi, \vec{d}, \vec{\mu}}^{\bullet}(\hat{Y}^{\text{rel}}) = \mathcal{M}_{\chi, \vec{d}, \vec{\mu}}^{\bullet}(\hat{\mathcal{Y}})_0$$

is the zero locus

$$\{s^v = 0 \mid v \in V_2(\Gamma)\} \subset \mathcal{M}_{\chi, \vec{d}, \vec{\mu}}^{\bullet}(\hat{\mathcal{Y}}).$$

The pair (\mathbf{L}^v, s^v) corresponds to $(\mathbf{L}_0, \mathbf{r}_0)$ in [20, Section 3].

4.3 Perfect obstruction theory

Let Γ be a FTCY graph, and let $(\vec{d}, \vec{\mu})$ be an effective class of Γ . We briefly describe the perfect obstruction theory of $\bar{\mathcal{M}}_{\chi, \vec{d}, \vec{\mu}}^{\bullet}(\hat{Y}^{\text{rel}})$ constructed in [20].

Define $\mathcal{M}_{\chi, \vec{d}, \vec{\mu}}^{\bullet}(\hat{\mathcal{Y}}) \rightarrow \mathbb{A}^{|V_2(\Gamma)|}$, $[\mathbf{T}^1 \rightarrow \mathbf{T}^2]$ and $\{\mathbf{L}^v \mid v \in V_2(\Gamma)\}$ as in Section 4.2. Let $[\tilde{\mathcal{T}}^1 \rightarrow \tilde{\mathcal{T}}^2]$ be the perfect obstruction theory on $\bar{\mathcal{M}}_{\chi, \vec{d}, \vec{\mu}}^{\bullet}(\hat{Y}^{\text{rel}})$. Let

$$u: (X, \mathbf{q}) \longrightarrow (\hat{Y}_{\mathbf{m}}, \hat{D}_{\mathbf{m}})$$

represent a point in $\bar{\mathcal{M}}_{\chi, \vec{d}, \vec{\mu}}^{\bullet}(\hat{Y}^{\text{rel}}) \subset \mathcal{M}_{\chi, \vec{d}, \vec{\mu}}^{\bullet}(\hat{\mathcal{Y}})$, where

$$\mathbf{q} = \{q_j^v \mid v \in V_1(\Gamma), 1 \leq j \leq \ell(\mu^v)\}.$$

We have the following exact sequence of vector spaces:

$$0 \longrightarrow \tilde{\mathcal{T}}_u^1 \longrightarrow \mathbf{T}_u^1 \longrightarrow \bigoplus_{v \in V_2(\Gamma)} \mathbf{L}_u^v \longrightarrow \tilde{\mathcal{T}}_u^2 \longrightarrow \mathbf{T}_u^2 \longrightarrow 0.$$

We will describe \mathbf{T}_u^1 , \mathbf{T}_u^2 , and \mathbf{L}_u^v explicitly. When Γ is a regular FTCY graph, that is when $V_2(\Gamma) = \emptyset$, the line bundles \mathbf{L}^v do not arise and $\mathcal{M}_{\chi, \vec{d}, \vec{\mu}}^{\bullet}(\hat{\mathcal{Y}}) = \bar{\mathcal{M}}_{\chi, \vec{d}, \vec{\mu}}^{\bullet}(\hat{Y}^{\text{rel}})$.

We need to introduce some notation. Given $\mathbf{m}: V_1(\Gamma) \cup V_2(\Gamma) \rightarrow \mathbb{Z}_{\geq 0}$, let $\check{\Gamma}_{m^v}^v$ be the flat chain of length $m^v = \mathbf{m}(v)$ associated to $v \in V_1(\Gamma) \cup V_2(\Gamma)$, and let

$$V(\check{\Gamma}_{\mathbf{m}}^v) = \{\check{v}_0^v, \dots, \check{v}_{m^v}^v\},$$

where $\check{v}_{m^v}^v \in V_1(\Gamma_{\mathbf{m}})$ if $v \in V_1(\Gamma)$.

Let $v \in V_1(\Gamma)$ and $0 \leq l \leq m^v - 1$, or let $v \in V_2(\Gamma)$ and $0 \leq l \leq m^v$. We define a line bundle L_l^v on the divisor \widehat{D}_l^v in \widehat{Y}_m by

$$L_l^v = N_{\widehat{D}_l^v/\Sigma(e_v)} \otimes N_{\widehat{D}_l^v/\Sigma(e'_v)}$$

where $v_0^{-1}(\bar{v}_l^v) = \{e_v, e'_v\}$. Note that L_l^v is a trivial line bundle on \widehat{D}_l^v .

With the above notation, we have

$$\mathbf{L}_u^v = \bigotimes_{l=0}^{m^v} H^0(\widehat{D}_l^v, L_l^v), \quad v \in V_2(\Gamma).$$

The tangent space \mathbf{T}_u^1 and the obstruction space \mathbf{T}_u^2 to $\mathcal{M}_{\chi, \vec{d}, \vec{\mu}}^\bullet(\widehat{Y})$ at the moduli point

$$[u: (X, \mathbf{q}) \rightarrow (\widehat{Y}_m, \widehat{D}_m)]$$

are given by the following two exact sequences:

$$(4-2) \quad 0 \rightarrow \text{Ext}^0(\Omega_X(R_{\mathbf{q}}), \mathcal{O}_X) \rightarrow H^0(\mathbf{D}^\bullet) \rightarrow \mathbf{T}_u^1 \\ \rightarrow \text{Ext}^1(\Omega_X(R_{\mathbf{q}}), \mathcal{O}_X) \rightarrow H^1(\mathbf{D}^\bullet) \rightarrow \mathbf{T}_u^2 \rightarrow 0$$

$$(4-3) \quad 0 \rightarrow H^0(u^*(\Omega_{\widehat{Y}_m}(\log \widehat{D}_m)))^\vee \rightarrow H^0(\mathbf{D}^\bullet) \\ \rightarrow \bigoplus_{\substack{v \in V_1(\Gamma) \\ 0 \leq l \leq m^v - 1}} H_{\text{ct}}^0(\mathbf{R}_l^{v^\bullet}) \oplus \bigoplus_{\substack{v \in V_2(\Gamma) \\ 0 \leq l \leq m^v}} H_{\text{ct}}^0(\mathbf{R}_l^{v^\bullet}) \rightarrow H^1(u^*(\Omega_{\widehat{Y}_m}(\log \widehat{D}_m)))^\vee \\ \rightarrow H^1(\mathbf{D}^\bullet) \rightarrow \bigoplus_{\substack{v \in V_1(\Gamma) \\ 0 \leq l \leq m^v - 1}} H_{\text{ct}}^1(\mathbf{R}_l^{v^\bullet}) \oplus \bigoplus_{\substack{v \in V_2(\Gamma) \\ 0 \leq l \leq m^v}} H_{\text{ct}}^1(\mathbf{R}_l^{v^\bullet}) \rightarrow 0$$

where

$$R_{\mathbf{q}} = \sum_{v \in V_1(\Gamma)} \sum_{j=1}^{\ell(\mu^v)} q_j^v,$$

$$H_{\text{ct}}^0(\mathbf{R}_l^{v^\bullet}) \cong \bigoplus_{q \in u^{-1}(\widehat{D}_l^v)} T_q(u^{-1}(\Sigma(e_v))) \otimes T_q(u^{-1}(\Sigma(e'_v))) \cong \mathbb{C}^{\oplus n_l^v}$$

for $v_0^{-1}(\bar{v}_l^v) = \{e_v, e'_v\}$,

$$(4-4) \quad H_{\text{ct}}^1(\mathbf{R}_l^{v^\bullet}) \cong H^0(\widehat{D}_l^v, L_l^v)^{\oplus n_l^v} / H^0(\widehat{D}_l^v, L_l^v),$$

and n_l^v is the number of nodes over \widehat{D}_l^v . In (4-4),

$$H^0(\widehat{D}_l^v, L_l^v) \longrightarrow H^0(\widehat{D}_l^v, L_l^v)^{\oplus n_l^v}$$

is the diagonal embedding.

We refer the reader to Li [20] for the definitions of $H^i(D^\bullet)$ and the maps between terms in (4-2), (4-3).

4.4 Formal relative Gromov–Witten invariants

Usually, the relative Gromov–Witten invariants are defined as integrations of the pull back classes from the target and the relative divisor. In the case studied, the analogue is to integrate a total degree $2 \sum_{v \in V_1(\Gamma)} \ell(\mu^v)$ class pull back from the relative divisor \widehat{D} . The class we choose is the product of the T -equivariant Poincaré dual $c_1^T(\mathcal{O}_{\widehat{D}^v}(\widehat{L}^v))$ of the divisor $\widehat{L}^v \subset \widehat{D}^v$, one for each marked point q_j^v . Equivalently, we consider the moduli space

$$\overline{\mathcal{M}}_{\chi, \vec{d}, \vec{\mu}}^\bullet(\widehat{Y}^{\text{rel}}, \widehat{L}) = \left\{ (u, X, \{q_j^v\}) \in \overline{\mathcal{M}}_{\chi, \vec{d}, \vec{\mu}}^\bullet(\widehat{Y}^{\text{rel}}) \mid u(q_j^v) \in \widehat{L}^v \right\}.$$

Its virtual dimension is zero. More precisely, let $[\mathcal{T}^1 \rightarrow \mathcal{T}^2]$ be the perfect obstruction theory on $\overline{\mathcal{M}}_{\chi, \vec{d}, \vec{\mu}}^\bullet(\widehat{Y}^{\text{rel}}, \widehat{L})$ and $[\widetilde{\mathcal{T}}^1 \rightarrow \widetilde{\mathcal{T}}^2]$ be the perfection obstruction theory on $\overline{\mathcal{M}}_{\chi, \vec{d}, \vec{\mu}}^\bullet(\widehat{Y}^{\text{rel}})$. Given a moduli point

$$[u: (X, \mathbf{x}) \rightarrow (\widehat{Y}_{\mathbf{m}}, \widehat{D}_{\mathbf{m}})] \in \overline{\mathcal{M}}_{\chi, \vec{d}, \vec{\mu}}^\bullet(\widehat{Y}^{\text{rel}}, \widehat{L}) \subset \overline{\mathcal{M}}_{\chi, \vec{d}, \vec{\mu}}^\bullet(\widehat{Y}^{\text{rel}}),$$

we have

$$\mathcal{T}_u^1 - \mathcal{T}_u^2 = \widetilde{\mathcal{T}}_u^1 - \widetilde{\mathcal{T}}_u^2 - \bigoplus_{v \in V_1(\Gamma)} \bigoplus_{j=1}^{\ell(\mu^v)} (N_{\widehat{L}^v / \widehat{D}^v})_{u(q_j^v)}$$

as virtual vector spaces.

In the rest of this subsection (Section 4.4), we fix $\chi, \Gamma, \vec{d}, \vec{\mu}$, and write \mathcal{M} instead of $\overline{\mathcal{M}}_{\chi, \vec{d}, \vec{\mu}}^\bullet(\widehat{Y}^{\text{rel}}, \widehat{L})$. We now define the formal relative Gromov–Witten invariants of \widehat{Y}^{rel} by applying the virtual localization to the moduli stack \mathcal{M} . We use the equivariant intersection theory developed by Edidin and Graham [6] and the localization by Edidin and Graham [7] and Graber and Pandharipande [11].

Since \widehat{Y}^{rel} is toric, the moduli space \mathcal{M} and its obstruction theory are T -equivariant. We consider the fixed loci \mathcal{M}^T of the T -action on \mathcal{M} . The coarse moduli space of \mathcal{M}^T is projective. The virtual localization is an integration of the quotient equivariant Euler classes. When $[u]$ varies in a connected component of \mathcal{M}^T , the vector spaces \mathcal{T}_u^1 and \mathcal{T}_u^2 form two vector bundles. We denoted them by \mathcal{T}^1 and \mathcal{T}^2 . Since the

obstruction theories are T -equivariant, both \mathcal{T}^i are T -equivariant. We let $\mathcal{T}^{i,f}$ and $\mathcal{T}^{i,m}$ be the fixed and the moving parts of \mathcal{T}^i . Since the fixed part $\mathcal{T}^{i,f}$ induces a perfect obstruction theory of \mathcal{M}^T , it defines a virtual cycle

$$[\mathcal{M}^T]^{\text{vir}} \in A_*(\mathcal{M}^T),$$

where $A_*(\mathcal{M}^T)$ is the Chow group with rational coefficients.

The perfect obstruction theory $[\mathcal{T}^{1,f} \rightarrow \mathcal{T}^{2,f}]$ together with the trivial T -action defines a T -equivariant virtual cycle

$$[\mathcal{M}^T]^{\text{vir},T} \in A_*^T(\mathcal{M}^T).$$

Since T acts on \mathcal{M}^T trivially, we have [7, Proposition 2]

$$A_*^T(\mathcal{M}^T) \cong A_*(\mathcal{M}) \otimes \Lambda_T$$

where $\Lambda_T = \text{Hom}(T, \mathbb{C}^*) \cong A_*^T(\text{pt}) \cong \mathbb{Q}[u_1, u_2]$.

The moving part $\mathcal{T}^{i,m}$ is the virtual normal bundles of \mathcal{M}^T in \mathcal{M} . Let

$$e^T(\mathcal{T}^{i,m}) \in A_T^*(\mathcal{M}^T)$$

be the T -equivariant Euler class of $\mathcal{T}^{i,m}$, where $A_T^*(\mathcal{M}^T)$ is the T -equivariant operational Chow group (see [6, Section 2.6]). For $i = 1, 2$, $e^T(\mathcal{T}^{i,m})$ lies in the subring

$$A^*(\mathcal{M}^T) \otimes \mathbb{Q}[u_1, u_2] \subset A_T^*(\mathcal{M}^T)$$

and is invertible in

$$A^*(\mathcal{M}^T) \otimes \mathbb{Q}[u_1, u_2]_{\mathfrak{m}} \subset A_T^*(\mathcal{M}^T)_{\mathfrak{m}}.$$

Here the subscript $(\)_{\mathfrak{m}}$ is localization at the ideal $\mathfrak{m} = (u_1, u_2)$ (cf [7, Section 4]).

We can also define a degree homomorphism $\text{deg}_{\mathfrak{m}}$ as follows. By [7, Theorem 1],

$$A_*^T(\mathcal{M})_{\mathfrak{m}} \cong A_*^T(\mathcal{M}^T)_{\mathfrak{m}} \cong A_*(\mathcal{M}^T) \otimes \mathbb{Q}[u_1, u_2]_{\mathfrak{m}},$$

so we may generalize the degree map $\text{deg}: A_0(\mathcal{M}^T) \rightarrow \mathbb{Q}$ to

$$\text{deg}_{\mathfrak{m}}: A_d(\mathcal{M}^T)_{\mathfrak{m}} \rightarrow \mathbb{Q}[u_1, u_2]_{\mathfrak{m}}$$

by

$$a \otimes b \mapsto \begin{cases} \text{deg}(a) \cdot b & d = 0, \\ 0 & d \neq 0. \end{cases}$$

Also, for $c \in A_T^*(X)_{\mathfrak{m}}$ and $\alpha \in A_*^T(X)_{\mathfrak{m}}$, we agree

$$\int_{\alpha} c = \text{deg}_{\mathfrak{m}}(c \cap \alpha) \in \mathbb{Q}[u_1, u_2]_{\mathfrak{m}}.$$

Following the lead of the virtual localization formula [11], we define:

Definition 4.7 (Formal relative Gromov–Witten invariants)

$$(4-5) \quad F_{\chi, \vec{d}, \vec{\mu}}^{\bullet \Gamma}(u_1, u_2) = \frac{1}{|\text{Aut}(\vec{\mu})|} \int_{[\mathcal{M}^T]^{\text{vir}, T}} \frac{e^T(\mathcal{T}^{2,m})}{e^T(\mathcal{T}^{1,m})}$$

where we view $[\mathcal{M}^T]^{\text{vir}, T}$ as an element in $A_*^T(\mathcal{M}^T)_m$.

Note that

$$\frac{e^T(\mathcal{T}^{2,m})}{e^T(\mathcal{T}^{1,m})} \cap [\mathcal{M}^T]^{\text{vir}, T} \in (A_*^T(\mathcal{M}^T)_m)_0$$

where $(A_*^T(\mathcal{M}^T)_m)_0$ is the degree zero part of the graded ring $A_*^T(\mathcal{M}^T)_m$. Therefore,

$$F_{\chi, \vec{d}, \vec{\mu}}^{\bullet \Gamma}(u_1, u_2) \in (\mathbb{Q}[u_1, u_2]_m)_0 = \mathbb{Q}(u_1/u_2)$$

where $(\mathbb{Q}[u_1, u_2]_m)_0$ is the degree zero part of the graded ring $\mathbb{Q}[u_1, u_2]_m$.

Since \mathcal{M} usually is not proper, a priori the integral (4-5) may depend on u_1/u_2 . Nevertheless, in this case we have:

Theorem 4.8 *The function $F_{\chi, \vec{d}, \vec{\mu}}^{\bullet \Gamma}(u_1, u_2)$ is independent of u_1, u_2 ; hence is a rational number depending only on Γ, χ, \vec{d} and $\vec{\mu}$.*

In Section 6 and Section 7, we will reduce the invariance of $F_{\chi, \vec{d}, \vec{\mu}}^{\bullet \Gamma}(u_1, u_2)$ (Theorem 4.8) to the invariance for a special topological vertex (Theorem 5.2).

5 Invariance of the topological vertex

We begin with the notion of topological vertex and topological vertex with standard framing.

Definition 5.1 (Topological vertex and standard framing) A topological vertex is a FTCY graph that has one trivalent vertex and three univalent vertices (see Figure 10 in Section 6). A topological vertex with a standard framing is a topological vertex whose three edges e_1, e_2 and e_3 that share the only vertex v_0 as their initial vertices have their position and framing maps satisfying (see Figure 7)

$$f(e_1) = p(e_2), \quad f(e_2) = p(e_3) \quad \text{and} \quad f(e_3) = p(e_1).$$

In this section, we shall prove:

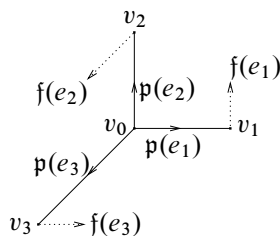

Figure 7: A topological vertex with standard framing

Theorem 5.2 (Invariance of the topological vertex) *Theorem 4.8 holds for any topological vertex with standard framing.*

We fix a topological vertex with standard framing Γ once and for all in this section; we let $\hat{Y}^{\text{rel}} = (\hat{Y}, \hat{D})$ be its associated FTCY threefold. As before, we continue to denote by T the group $(\mathbb{C}^*)^2$ and abbreviate $\bar{\mathcal{M}}_{\chi, \vec{d}, \vec{\mu}}^\bullet(\hat{Y}^{\text{rel}}, \hat{L})$ by \mathcal{M} .

Our strategy to prove the invariance of

$$(5-1) \quad F_{\chi, \vec{d}, \vec{\mu}}^{\bullet, \Gamma}(u_1, u_2) = \frac{1}{|\text{Aut}(\vec{\mu})|} \int_{[\mathcal{M}^T]_{\text{vir}}} \frac{e^T(\mathcal{T}^{2,m})}{e^T(\mathcal{T}^{1,m})} \in \mathbb{Q}(u_1/u_2)$$

is to construct a new proper T -equivariant DM-stack Ξ with perfect obstruction theory and a T -morphism

$$\Phi: \mathcal{M} (= \bar{\mathcal{M}}_{\chi, \vec{d}, \vec{\mu}}^\bullet(\hat{Y}^{\text{rel}}, \hat{L})) \longrightarrow \Xi$$

so that

- (1) the induced map on the T -fixed loci $\Phi^T: \mathcal{M}^T \longrightarrow \Xi^T$ is an open and closed embedding;
- (2) the obstruction theory of \mathcal{M} along its fixed loci is identical to that of Ξ via Φ^T .

Once we have Φ , we shall take $\Xi_1 = \Phi(\mathcal{M})$ (as a closed subset), which is T -invariant. Because of the equivalence of obstruction theories stated, we have

$$\int_{[\mathcal{M}^T]_{\text{vir}}} \frac{e^T(\mathcal{T}^{2,m})}{e^T(\mathcal{T}^{1,m})} = \int_{[\Xi_1^T]_{\text{vir}}} \frac{e^T(\mathcal{T}^{2,m})}{e^T(\mathcal{T}^{1,m})},$$

(Here by abuse of notation, we denote by $\mathcal{T}^{i,m}$ the moving parts of the obstruction complex $[\mathcal{T}^1 \rightarrow \mathcal{T}^2]$ of \mathcal{M} as well as Ξ along their fixed loci.)

To prove the invariance of the right hand side, we shall prove that we can pick another T -invariant closed subsets $\Xi_2 \subset \Xi$ that is disjoint from Ξ_1 so that the fixed loci

$$\Xi^T = \Xi_1^T \cup \Xi_2^T$$

and that the element $[\Xi]^{\text{vir}, T}$ lifts to an element in $A_0^T(\Xi_1 \cup \Xi_2)$ via the tautological

$$A_0^T(\Xi_1 \cup \Xi_2) \longrightarrow A_0^T(\Xi).$$

On the other hand, we will show that the image of this lift under the composition

$$A_0^T(\Xi_1 \cup \Xi_2) \longrightarrow A_0^T(\Xi_1) \longrightarrow A_0(\Xi_1^T)_m \xrightarrow{\text{deg}_m} \mathbb{Q}(u_1, u_2)$$

is $F_{\chi, \vec{d}, \vec{\mu}}^{\bullet \Gamma}(u_1, u_2)$ in (5-1). Since the degree map $A_0^T(\Xi_1) \rightarrow \mathbb{Q}$ takes values in \mathbb{Q} , this will prove that the formal expression $F_{\chi, \vec{d}, \vec{\mu}}^{\bullet \Gamma}(u_1, u_2)$ is a rational number, thus proving the invariance theorem.

5.1 The relative Calabi–Yau manifold W^{rel} and the morphism Φ

We shall construct the stack Ξ and the T –equivariant morphism Φ promised. The stack Ξ will be constructed as the moduli of relative stable morphisms to a pair of a nonsingular projective T –threefold W with a relative divisor $D \subset W$ and a subdivisor $L \subset D$. The morphism Φ will follow once we choose (W, D) so that there is a T –morphism $(\hat{Y}, \hat{D}) \rightarrow (W, D)$.

We begin with constructing the toric variety W^{rel} . Looking at the graph Γ chosen, the obvious choice of W is the toric blowup of $\mathbb{P}^1 \times \mathbb{P}^1 \times \mathbb{P}^1$ along three disjoint lines

$$\ell_1 = \infty \times \mathbb{P}^1 \times 0, \quad \ell_2 = 0 \times \infty \times \mathbb{P}^1 \quad \text{and} \quad \ell_3 = \mathbb{P}^1 \times 0 \times \infty.$$

The moment polytope of W , which is the image of the moment map

$$\Upsilon: W \longrightarrow \mathbb{R}^3,$$

can be identified with the quotient $W/U(1)^3$ of W by $U(1)^3 \subset (\mathbb{C}^*)^3$, as shown in Figure 8. Here we follow the convention that (z_1, z_2, z_3) is the point $([z_1, 1], [z_2, 1], [z_3, 1])$ in $(\mathbb{P}^1)^3$. We let $D \subset W$ be the exceptional divisor and let $D_i \subset D$ be its connected component lying over ℓ_i . Each D_i is isomorphic to $\mathbb{P}^1 \times \mathbb{P}^1$. We then let C_1, C_2 and C_3 be the proper transforms of

$$\mathbb{P}^1 \times 0 \times 0, \quad 0 \times \mathbb{P}^1 \times 0 \quad \text{and} \quad 0 \times 0 \times \mathbb{P}^1,$$

and let $L_i \subset D_i$, $i = 1, 2$ and 3 , be the preimages of

$$(\infty, 0, 0) \in \ell_1, \quad (0, \infty, 0) \in \ell_2 \quad \text{and} \quad (0, 0, \infty) \in \ell_3.$$

Clearly, restricting to C_i the log-canonical sheaf

$$(5-2) \quad \wedge^3 \Omega_W(\log D)|_{C_i} \cong \mathcal{O}_{C_i}.$$

Hence to the curves C_i the relative pair $W^{\text{rel}} = (W, D)$ is practically a relative Calabi–Yau threefold.

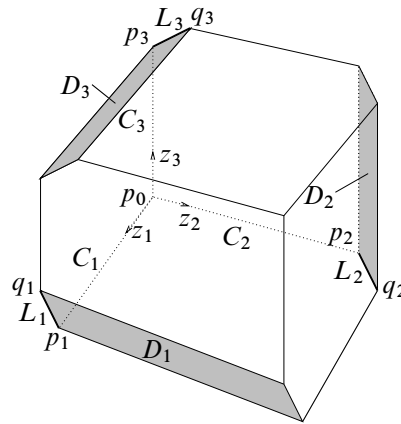

Figure 8: Moment polytope of W . All faces of this polytope represent the $(\mathbb{C}^*)^3$ invariant divisors of W . The point p_0 is the image of the point $(0, 0, 0) \in W$. The line $\overline{p_0 p_i}$ is the image of the curve $C_i \cong \mathbb{P}^1$, and the thickened line $\overline{p_i q_i}$ is the image of the curve $L_i \cong \mathbb{P}^1$. The rectangle face containing the edge $\overline{p_i q_i}$ is the image of the relative divisor $D_i \cong \mathbb{P}^1 \times \mathbb{P}^1$.

For clarity of presentation, we will follow the convention that under the isomorphisms $D_i \cong \mathbb{P}^1 \times \mathbb{P}^1$ and $\ell_i \cong \mathbb{P}^1$, the tautological projection $D_i \rightarrow \ell_i$ is the first projection. Under this convention, the line $L_i \subset D_i$ is the line $0 \times \mathbb{P}^1$ and the intersection $p_i = C_i \cap D_i$ is the point $(0, 0)$.

As to the torus action, we pick the obvious one on $(\mathbb{P}^1)^3$ via

$$(z_1, z_2, z_3)^{(t_1, t_2, t_3)} = (t_1 z_1, t_2 z_2, t_3 z_3), \quad (t_1, t_2, t_3) \in (\mathbb{C}^*)^3.$$

It lifts to a $(\mathbb{C}^*)^3$ -action on W that leaves D_i and L_i invariant. We let $T \subset (\mathbb{C}^*)^3$ be the subgroup defined by $t_1 t_2 t_3 = 1$; it is isomorphic to $(\mathbb{C}^*)^2$ and is the subgroup that leaves (5-2) invariant. In the following, we shall view $W^{\text{rel}} = (W, D)$ as a relative Calabi–Yau T -manifold to the curves C_i .

Next we will define the moduli space $\mathcal{M}_{\chi, \vec{d}, \vec{\mu}}^\bullet(W^{\text{rel}}, L)$. Clearly, each C_i induces a homology class $[C_i] \in H_2(W; \mathbb{Z})$. For $\vec{\mu} = (\mu^1, \mu^2, \mu^3) \in \mathcal{P}_+^3$, we let \vec{d} be the homology class

$$\vec{d} = |\mu^1|[C_1] + |\mu^2|[C_2] + |\mu^3|[C_3] \in H_2(W; \mathbb{Z}).$$

The pair $(\vec{d}, \vec{\mu})$ is an effective class of Γ :

$$\vec{d}(\bar{e}_i) = |\mu^i|, \quad \vec{\mu}(v_i) = \mu^i, \quad i = 1, 2, 3.$$

We then let

$$\mathcal{M}_{\chi, \vec{d}, \vec{\mu}}^{\bullet}(W^{\text{rel}}, L)$$

be the moduli of relative stable morphisms

$$u: (X; R_1, R_2, R_3) \longrightarrow W^{\text{rel}} = (W, D_1, D_2, D_3),$$

where $R_i \subset X$ are the relative divisors of u to $D_i \subset W$ (namely $u^{-1}(D_i) = R_i$), that have fundamental classes \vec{d} , have ramification patterns μ^i along D_i , and satisfy $u(R_i) \subset L_i$, modulo the equivalence relation introduced in [20]. It is a proper, separated DM-stack; it has a perfect obstruction theory [19; 20], and thus admits a virtual cycle. This moduli stack $\mathcal{M}_{\chi, \vec{d}, \vec{\mu}}^{\bullet}(W^{\text{rel}}, L)$ is the stack Ξ we aimed to construct.

It follows from our construction that the scheme Y , which is the closure of the three one-dimensional orbits in \hat{Y} , can be identified with the union $C_1 \cup C_2 \cup C_3$ in W ; the formal scheme \hat{Y} is isomorphic to the formal completion of W along Y . Further, the relative divisor \hat{D} of \hat{Y} (resp. the subdivisor $\hat{L} \subset \hat{D}$) is the preimage of the relative divisor $D \subset W$ (resp. the subdivisor $L \subset D$); the induced morphism

$$\phi: (\hat{Y}, \hat{D}, \hat{L}) \longrightarrow (W, D, L)$$

is T -equivariant; and the two effective classes $(\vec{d}, \vec{\mu})$ are consistent under the map ϕ . Therefore, it induces a T -equivariant morphism of moduli spaces

$$\Phi: \mathcal{M} (= \bar{\mathcal{M}}_{\chi, \vec{d}, \vec{\mu}}^{\bullet}(\hat{Y}^{\text{rel}}, \hat{L})) \longrightarrow \Xi (= \mathcal{M}_{\chi, \vec{d}, \vec{\mu}}^{\bullet}(W^{\text{rel}}, L))$$

that induces a morphism

$$\Phi^T: \mathcal{M}^T \longrightarrow \Xi^T$$

between their respective fixed loci.

Lemma 5.3 *The morphism Φ^T is an open and closed embedding; the obstruction theories of \mathcal{M} and Ξ are identical under Φ along the fixed loci \mathcal{M}^T and its image in Ξ^T .*

Proof This follows immediately from that C_1, C_2 and C_3 are the closures of three one-dimensional orbits, that $Y = C_1 \cup C_2 \cup C_3$ and that \hat{Y} is the formal completion of W along Y . □

We let Ξ_1 be the image $\Phi(\mathcal{M})$, as a closed substack of Ξ . Since Φ is T -equivariant, Ξ_1 is T -invariant.

5.2 A constancy criterion

We now construct the other T -invariant closed subset Ξ_2 and verify the sufficient condition for the constancy of (5-1) briefly mentioned at the beginning of this section.

First, since T acts on Ξ , for any closed point $u \in \Xi$, the stabilizer $\text{Stab}_T(u)$ of u is a subgroup of T . For those points u that are fixed by T (so that $\text{Stab}_T(u) = T$), we have:

Lemma 5.4 *The fixed loci Ξ_1^T is a closed and open subset of the fixed loci Ξ^T .*

Proof The lemma will follow from the classification result in the next subsection. \square

We now choose a T -invariant, closed $\Xi_2 \subset \Xi$ that contains $\Xi^T - \Xi_1^T$ and is disjoint from Ξ_1 . We let $U = \Xi - \Xi^T$. For any one-dimensional subtorus $G \subset T$ we let U^G be the closed subset of those u with $\text{stab}_T(u)_0 = G$, where $\text{stab}_T(u)_0 \subset \text{stab}_T(u)$ is the connected component of the identity. Accordingly, we let $U^0 \subset U$ be the open subset of those elements with finite stabilizers. Since Ξ is proper, there is a finite set Λ of one-dimensional subtorus $G \subset T$ with nonempty U^G . For each such G , we let U_1^G be the union of those connected components of U^G whose closures in Ξ are disjoint from Ξ_1 . Since the difference

$$\overline{U_1^G} - U_1^G \subset \Xi^T$$

and is disjoint from Ξ_1^T , it is contained in $\Xi^T - \Xi_1^T$. Thus

$$\Xi_2 = (\Xi^T - \Xi_1^T) \cup \bigcup_{G \in \Lambda} U_1^G$$

is T -invariant, closed, containing $\Xi^T - \Xi_1^T$ and disjoint from Ξ_1 .

Since both Ξ_1 and Ξ_2 are T -invariant and closed, we have the exact sequence of T -equivariant Chow groups

$$A_0^T(\Xi_1 \cup \Xi_2) \longrightarrow A_0^T(\Xi) \xrightarrow{\beta} A_0^T(\Xi - \Xi_1 \cup \Xi_2) \longrightarrow 0.$$

Therefore, a $\xi \in A_0^T(\Xi)$ lifts to $A_0^T(\Xi_1 \cup \Xi_2)$ if and only if $\beta(\xi) = 0$.

Unfortunately, the technique we shall apply only gives the vanishing of $\beta([\Xi])^{\text{vir}, T}$ in the ordinary equivariant homology group, not the equivariant Chow-group. To accommodate this, we shall work with the equivariant homology groups instead.

We let $T_{\mathbb{R}}$ be the maximal real subgroup $U(1)^{\times 2} \subset T$. We let $B^l T = (\mathbb{C}^{l+1} - 0)^{\times 2}$ and $B^l T_{\mathbb{R}} = (S^{2l+1})^{\times 2}$ be the finite approximation¹ of BT and $BT_{\mathbb{R}}$. For any proper DM-stack M , we define

$$H_i^{T_{\mathbb{R}}}(M) = \lim_l H_{i+4l}(M \times_{T_{\mathbb{R}}} B^l T_{\mathbb{R}}), \quad H_* \text{ the BM-homology}$$

parallel to the definition of the equivariant Chow-group

$$A_i^T(M) = \lim_l A_{i+2l}(M \times_T B^l T).$$

Because $M \times_{T_{\mathbb{R}}} B^l T_{\mathbb{R}} = M \times_T B^l T$ and M is proper, we have a tautological homomorphism $A_i^T(M) \rightarrow H_{2i}^{T_{\mathbb{R}}}(M)$.

In the remainder of this section, for any class in $A_i^T(\mathfrak{E})$, we shall not distinguish it with its image in $H_{2i}^{T_{\mathbb{R}}}(\mathfrak{E})$. Since our ultimate goal is to investigate the degree of the cycles in $A_0^T(\mathfrak{E}_1)_m$, there is no loss of generality if we replace A_*^T by $H_{2*}^{T_{\mathbb{R}}}$ since the degree maps commute with the tautological map from A_0^T to $H_0^{T_{\mathbb{R}}}$.

For $\xi \in H_0^{T_{\mathbb{R}}}(\mathfrak{E})$, we let $\xi^T \in H_0^{T_{\mathbb{R}}}(\mathfrak{E}^T)_m$ be the associated element under the localization isomorphism

$$H_0^{T_{\mathbb{R}}}(\mathfrak{E})_m \cong H_0^{T_{\mathbb{R}}}(\mathfrak{E}^T)_m.$$

(Here we follow the convention introduced in the previous section that m is the ideal $(u_1, u_2) \subset H_T^*(\text{pt})$ and the subscript m means the localization by m .) We let $\xi_1^T + \xi_2^T = \xi^T$ be the decomposition of ξ^T under the tautological isomorphism

$$H_0^{T_{\mathbb{R}}}(\mathfrak{E}^T)_m = H_0^{T_{\mathbb{R}}}(\mathfrak{E}_1^T)_m \oplus H_0^{T_{\mathbb{R}}}(\mathfrak{E}_2^T)_m.$$

Lemma 5.5 *Let $\xi \in H_0^{T_{\mathbb{R}}}(\mathfrak{E})$ be any equivariant element. Suppose ξ can be lifted to an $\eta \in H_0^{T_{\mathbb{R}}}(\mathfrak{E}_1 \cup \mathfrak{E}_2)$. Then the component $\eta_1 \in H_0^{T_{\mathbb{R}}}(\mathfrak{E}_1)$ of η has the property that $\eta_1^T = \xi_1^T$. Consequently, under the composition of the restriction and the degree homomorphisms*

$$\text{deg}^T: H_0^{T_{\mathbb{R}}}(\mathfrak{E}_1)_m \rightarrow H_0(\mathfrak{E}_1^T) \otimes_{\mathbb{Q}} \mathbb{Q}[u_1, u_2]_m \rightarrow \mathbb{Q}[u_1, u_2]_m,$$

ξ_1^T is mapped to a constant (independent of u_1 and u_2).

¹ $T = \mathbb{C}^* \times \mathbb{C}^*$ acts on $B^l T$ via the product of the standard \mathbb{C}^* action on \mathbb{C}^{l+1} by multiplication: $v^\sigma = \sigma \cdot v$ for $\sigma \in \mathbb{C}^*$ and $v \in \mathbb{C}^{l+1}$. The $T_{\mathbb{R}}$ action on $B^l T_{\mathbb{R}}$ is the one induced by T on $B^l T$.

Proof Suppose ξ lifts to an $\eta \in H_0^{T\mathbb{R}}(\Xi_1 \cup \Xi_2)$. Since Ξ_1 and Ξ_2 are disjoint, $\eta = \eta_1 + \eta_2$ for $\eta_j \in H_0^{T\mathbb{R}}(\Xi_j)$. Then by the localization theorem,

$$\begin{array}{ccc} H_0^{T\mathbb{R}}(\Xi_1 \cup \Xi_2)_m & \longrightarrow & H_0^{T\mathbb{R}}(\Xi)_m \\ \uparrow \cong & & \uparrow \cong \\ H_0^{T\mathbb{R}}(\Xi_1^T)_m \oplus H_0^{T\mathbb{R}}(\Xi_2^T)_m & \xrightarrow{\cong} & H_0^{T\mathbb{R}}(\Xi^T)_m \end{array}$$

is commutative. Let $\eta_j^T \in H_0^{T\mathbb{R}}(\Xi_j^T)_m$ be the element associated to η_j via the left vertical arrows. Then since $\eta = \eta_1 + \eta_2$ is mapped to ξ under the top horizontal arrow, $\xi_1^T = \eta_1^T$. On the other hand, since η_1 is an equivariant homology class, $\deg^T(\eta_1^T) = \deg(\eta_1) \in \mathbb{Q}$. Thus $\deg^T(\xi_1^T) \in \mathbb{Q}$ as well. This proves the lemma. \square

Following the lemma, to prove the invariance theorem we only need to check that the class $[\Xi]^{\text{vir}, T}$ lifts. For this purpose, we need a detailed classification of those $u \in \Xi$ that are invariant under one-dimensional subtori $G \subset T$.

5.3 Elements with nontrivial stabilizers

Let $a_1, a_2, a_3 \in \mathbb{Z}$ with $a_1 + a_2 + a_3 = 0$ be three relatively prime integers and let G be the subtorus

$$G = \{(t^{a_1}, t^{a_2}, t^{a_3}) \mid t \in \mathbb{C}^*\} \subset T.$$

Our task is to characterize those stable relative morphisms that are invariant under $G \subset T$ and are small deformations of elements in Ξ_1 , where $\Xi_1 = \Phi(\mathcal{M})$.

To investigate relative stable morphisms to W , we need the expanded relative pairs $(W[\mathbf{m}], D[\mathbf{m}])$, $\mathbf{m} = (m_1, m_2, m_3)$ (see Figure 9). We let Δ be the projective bundle

$$\mathbb{P}(\mathcal{O}_{\mathbb{P}^1 \times \mathbb{P}^1} \oplus \mathcal{O}_{\mathbb{P}^1 \times \mathbb{P}^1}(0, 1))$$

over $\mathbb{P}^1 \times \mathbb{P}^1$ with two sections

$$D_+ = \mathbb{P}(\mathcal{O}_{\mathbb{P}^1 \times \mathbb{P}^1} \oplus 0) \quad \text{and} \quad D_- = \mathbb{P}(0 \oplus \mathcal{O}_{\mathbb{P}^1 \times \mathbb{P}^1}(0, 1));$$

we form an m_i -chain of Δ by gluing m_i copies of Δ via identifying the D_- of one Δ to the D_+ of the next Δ using the canonical isomorphism $\text{pr}: D_{\pm} \rightarrow \mathbb{P}^1 \times \mathbb{P}^1$; we then attach this chain to D_i by identifying the D_+ of the first Δ in the chain with D_i and declaring the D_- of the last Δ be $D[\mathbf{m}]_i$. The scheme $W[\mathbf{m}]$ is the result after attaching such three chains, of length m_1, m_2 and m_3 respectively, to D_1, D_2 and D_3 in W . The union

$$D[\mathbf{m}] = D[\mathbf{m}]_1 \cup D[\mathbf{m}]_2 \cup D[\mathbf{m}]_3$$

is the new relative divisor of $W[\mathbf{m}]$. Note that our construction is consistent with that the normal bundle of D_i in W has degree -1 along L_i .

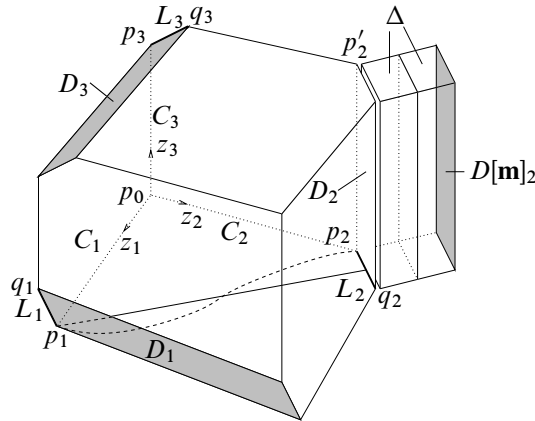

Figure 9: A sketch of the scheme $W[\mathbf{m}]$ for $\mathbf{m} = (0, 2, 0)$. The main part is the moment polytope of W (see Figure 8). The added two solids to the right are the two Δ 's attached to D_2 , resulting the scheme $W[\mathbf{m}]$ with $\mathbf{m} = (0, 2, 0)$. The shaded faces are the relative divisor $D[\mathbf{m}]$ of $W[\mathbf{m}]$. The straight diagonal line contained in the bottom face indicates the image of $\phi_{k,c}$ in case $\eta = (1, -1, 0)$; the curved line indicates the image of $\phi_{k,c}$ in the other case.

For future convenience, we denote by $\Delta[m_i]$ the chain of Δ 's that is attached to D_i ; we denote by $L[\mathbf{m}]_i \subset D[\mathbf{m}]_i$ the same line as $L_i \subset D_i$. The new scheme $W[\mathbf{m}]$ contains W as its main irreducible component; it also admits a stable contraction $W[\mathbf{m}] \rightarrow W$ whose restriction to the main component is the identity and its restriction to $\Delta[m_i]$ is the tautological projection $\Delta[m_i] \rightarrow D_i$. Also, $(\mathbb{C}^*)^3$ acts on $(W[\mathbf{m}], D[\mathbf{m}])$ since the $(\mathbb{C}^*)^3$ -action on $N_{D_i/W}$ induces a $(\mathbb{C}^*)^3$ -action on each Δ attached to D_i . Therefore $(\mathbb{C}^*)^3$ and T act on Ξ . Unless otherwise mentioned, the maps $W \rightarrow W[\mathbf{m}]$ and $W[\mathbf{m}] \rightarrow W$ are these inclusion and projection; these maps are $(\mathbb{C}^*)^3$ -equivariant.

The pair (W, D) contains (Y, p) , $p = p_1 + p_2 + p_3$, as its subpair. Accordingly, the pair $(W[\mathbf{m}], D[\mathbf{m}])$ contains a subpair $(Y[\mathbf{m}], p[\mathbf{m}])$ whose main part $Y[\mathbf{m}]$ is the preimage of Y under the contraction $W[\mathbf{m}] \rightarrow W$. The relative divisor $p[\mathbf{m}]$ is the intersection $Y[\mathbf{m}] \cap D[\mathbf{m}]$. It is the embedding $Y[\mathbf{m}] \subset W[\mathbf{m}]$ that induces the embedding $\Xi_1 \subset \Xi$.

We now fix a one-dimensional subtorus $G \subset T$. We let u_0 be a relative stable morphism in Ξ_1 , considered as an element in Ξ ; we let u_s be a small deformation² of u_0 in Ξ^G that is not entirely contained in Ξ_1 . Each u_s is a morphism from its domain X_s to $W[\mathbf{m}]$ for some triple \mathbf{m} possibly depending on s . We let $\tilde{u}_s: X_s \rightarrow W$ be the composite of u_s with the contraction $W[\mathbf{m}] \rightarrow W$. Then \tilde{u}_s form a flat family of morphisms. This family specializes to \tilde{u}_0 as s specializes to 0. Hence as sets, $\tilde{u}_s(X_s)$ specializes to $\tilde{u}_0(X_0)$ as s specializes to 0. Because $\tilde{u}_s(X_s)$ are union of algebraic curves in W and $\tilde{u}_0(X_0)$ is contained in $C_1 \cup C_2 \cup C_3$, for general s the intersection $\tilde{u}_s(X_s) \cap D$ is discrete. Hence every irreducible component $Z \subset \tilde{u}_s^{-1}(D_i)$ must be mapped to a fiber of $\Delta[m_i]/D_i$.

Now suppose there is such a connected component Z with $u_s(Z)$ lies in the fiber of $\Delta[m_i]$ over $q \in D_i$, then the predeformable requirement on relative stable morphisms forces the same q in $D[\mathbf{m}]_i$ to lie in $u_s(X_s)$. Because of the requirement $u_s(Z) \cap D[\mathbf{m}]_i \subset L[\mathbf{m}]_i$ imposed on elements in Ξ , we have

$$(5-3) \quad \tilde{u}_s(X_s) \cap D_i \subset L_i.$$

This leads to the following definition.

Definition 5.6 To each one-dimensional subtorus $G \subset T$, we define $\mathcal{M}_{\text{def}}^{T_\eta}$ to be the union of all connected components of

$$\{[u, X] \in \Xi^{T_\eta} \mid \tilde{u}(X) \cap D \text{ is finite}\}$$

that intersect but are not entirely contained in Ξ_1 .

Following the discussion before Definition 5.6, all u in $\mathcal{M}_{\text{def}}^{T_\eta}$ satisfy (5-3). In case $a_{i+1} \neq 0$ (we agree $a_4 = a_1$), the only T_η -fixed points of L_i are p_i and q_i ; hence all u in $\mathcal{M}_{\text{def}}^{T_\eta}$ satisfies a strengthened version to (5-3):

$$(5-4) \quad \tilde{u}_s(X) \cap D_i \subset p_i, \quad \text{when } a_{i+1} \neq 0.$$

Here q_i is ruled out because each connected component of $\mathcal{M}_{\text{def}}^{T_\eta}$ intersects Ξ_1 .

We now characterize elements in $\mathcal{M}_{\text{def}}^{T_\eta}$. We comment that we shall reserve a_1, a_2 and a_3 for the three relatively prime integers that defines G , as specified in the beginning of this subsection. In this and the next two Subsections, we shall work out the case $a_1 > 0$ and $a_2, a_3 < 0$; the case $\eta = (1, -1, 0)$ will be considered in Section 5.6.

² Here s should be viewed as varying in some smooth connected curve.

Now let $[u, X] \in \mathcal{M}_{\text{def}}^{T_\eta}$ and let $V \subset \tilde{u}(X)$ be any irreducible component. Since u is T_η -invariant, V is T_η -invariant. Hence V must be the lift of the set

$$\bar{V} = \{(c_1 t^{a_1}, c_2 t^{a_2}, c_3 t^{a_3}) \mid t \in \mathbb{C} \cup \{\infty\}\} \subset (\mathbb{P}^1)^3$$

for some (c_1, c_2, c_3) . This immediately rules out the following possibilities:

- (1) all c_i are nonzero: should this happen, then $\bar{V} \cap \ell_2 = (0, \infty, \infty)$, which violates (5-3);
- (2) $c_1 = 0$ but the other two are nonzero: should this happen, then either $V \cap D = V \cap D_1 = q_1$, or $V \cap D = V \cap D_2 = p'_2$ (see Figure 9 for the location of p'_2), which violates (5-4);
- (3) $c_2 = 0$ but the other two are nonzero: should this happen, then $V \cap D_1 = q_1$ since $a_1 > |a_3|$, which violates (5-4).

This leaves us with the only two possibilities: (a) only one of c_i is nonzero; (b) $c_3 = 0$ but the other two are nonzero. In case (a), we have $V = C_i$ for some i ; in case (b), V is the image of the map

$$\phi_{k,c}: \mathbb{P}^1 \longrightarrow W, \quad k \in \mathbb{Z}^+, c \in \mathbb{C}^*$$

that is the lift of $\mathbb{P}^1 \rightarrow (\mathbb{P}^1)^{\times 3}$ defined by $\xi \mapsto (\xi^{ka_1}, c^{-ka_2} \xi^{ka_2}, 0)$. Clearly, $\phi_{k,c}$ is G -invariant. It is easy to see that these are the only T_η -equivariant maps $Z \rightarrow W$ from irreducible Z whose images are not entirely contained in $C_1 \cup C_2 \cup C_3$ and in the divisor D . This proves:

Lemma 5.7 *Suppose $a_1 > 0$ and $a_2, a_3 < 0$. Then any $(u, X) \in \mathcal{M}_{\text{def}}^{T_\eta}$ not entirely contained in Y has at least one irreducible component $Z \subset X$ and a pair (k, c) so that $u|_Z \cong \phi_{k,c}$.*

Here by $u|_Z \cong \phi_{k,c}$ we mean that there is an isomorphism $Z \cong \mathbb{P}^1$ so that under this isomorphism $u|_Z \equiv \phi_{k,c}$.

When c specializes to 0, the map $\phi_{k,c}$ specializes to the morphism

$$\phi_{k,0}: \mathbb{P}^1 \sqcup \mathbb{P}^1 \longrightarrow W$$

defined as follows. We endow the first copy (of $\mathbb{P}^1 \sqcup \mathbb{P}^1$) with the coordinate ξ_1 and the second copy with ξ_2 ; we then form the nodal curve $\mathbb{P}^1 \sqcup \mathbb{P}^1$ by identifying the 0 of the first \mathbb{P}^1 with the 0 of the second \mathbb{P}^1 ; we define $\phi_{k,0}$ to be the lift of the maps

$$\xi_1 \mapsto (\xi_1^{ka_1}, 0, 0) \quad \text{and} \quad \xi_2 \mapsto (0, \xi_2^{-ka_2}, 0).$$

Since $\xi_1 = 0$ and $\xi_2 = 0$ are both mapped to the origin in $(\mathbb{P}^1)^{\times 3}$, they glue together to form a morphism $\phi_{k,0}: \mathbb{P}^1 \sqcup \mathbb{P}^1 \rightarrow W$.

This leads to the following definition.

Definition 5.8 A deformable part of a $(u, X) \in \mathcal{M}_{\text{def}}^{T_\eta}$ consists of a curve $Z \subset X$ and an isomorphism $u|_Z \cong \phi_{k,c}$ for some (k, c) .

Suppose (u, X) has at least two deformable parts, say (Z_1, ϕ_{k_1,c_1}) and (Z_2, ϕ_{k_2,c_2}) , then the explicit expression of $\phi_{k,c}$ ensures that Z_1 and Z_2 share no common irreducible components. Should $Z_1 \cap Z_2 \neq \emptyset$, their intersection would be a nodal point of X that could only be mapped to either D_1 or D_2 of W under u . (Note that it could not be mapped to p_0 since otherwise both $c_1 = c_2 = 0$ and this node would be in more than two irreducible components of X .) However, the case that the node is mapped to D_1 or D_2 can also be ruled out because it would violate the predeformable requirement of relative stable morphisms [19]. Hence Z_1 and Z_2 are disjoint. This way, we can talk about the maximal collection of deformable parts of (u, X) , say

$$(Z_1, \phi_{k_1,c_1}), \dots, (Z_l, \phi_{k_l,c_l}).$$

For convenience, we order it so that k_i is increasing.

Definition 5.9 We define the deformation type of $(u, X) \in \mathcal{M}_{\text{def}}^{T_\eta}$ be

$$(k_i)_l = (k_1 \leq k_2 \leq \dots \leq k_l).$$

It defines a function on $\mathcal{M}_{\text{def}}^{T_\eta}$, called the deformation type function.

Let (u, X) be an element in $\mathcal{M}_{\text{def}}^{T_\eta}$ of type $(k_i)_l$. Intuitively, we should be able to deform u within $\mathcal{M}_{\text{def}}^{T_\eta}$ by varying $u|_{Z_i}$ using $\phi_{k_i,t}$ to generate an \mathbb{A}^l -family in $\mathcal{M}_{\text{def}}^{T_\eta}$. It is our next goal to make this precise.

To proceed, we need to show how to put $\phi_{k,t}$ into a family. We first blow up $\mathbb{P}^1 \times \mathbb{A}^1$ at $(0, 0)$ to form a family of curves \mathfrak{Y} over \mathbb{A}^1 . The complement of the exceptional divisor $\mathfrak{Y} - E = \mathbb{P}^1 \times \mathbb{A}^1 - (0, 0)$ comes with an induced coordinate (ξ, t) . We define

$$\Phi_k|_{\mathfrak{Y}-E}: \mathfrak{Y} - E \longrightarrow W; \quad (\xi, t) \mapsto (\xi^{ka_1}, t^{-ka_2} \xi^{ka_2}, 0).$$

We claim that $\Phi_k|_{\mathfrak{Y}-E}$ extends to a morphism $\Phi_k: \mathfrak{Y} \rightarrow W$. Indeed, if we pick a local coordinate chart near E , which is (ξ, v) with $t = \xi v$, then

$$\Phi_k|_{\mathfrak{Y}-E}: (\xi, v) \mapsto (\xi^{ka_1}, (\xi v)^{-ka_2} \xi^{ka_2}, 0) = (\xi^{ka_1}, v^{-ka_2}, 0),$$

which extends to a regular morphism

$$\Phi_k: \mathfrak{Y} \longrightarrow W.$$

Note that for $c \in \mathbb{A}^1$, the fiber of (Φ_k, \mathfrak{Y}) over c is exactly the $\phi_{k,c}$ we defined earlier. Henceforth, we will call (Φ_k, \mathfrak{Y}) the standard model of the family $\phi_{k,t}$; we will use \mathfrak{Y}_c to denote the fiber of \mathfrak{Y} over $c \in \mathbb{A}^1$.

To deform u using the family Φ_k , we need to glue \mathfrak{Y} onto the domain X . We let \mathfrak{D}_1 be the proper transform of $0 \times \mathbb{A}^1 \subset \mathbb{P}^1 \times \mathbb{A}^1$ and let $\mathfrak{D}_2 = \infty \times \mathbb{A}^1$ in \mathcal{Y} . Both \mathfrak{D}_1 and \mathfrak{D}_2 are canonically isomorphic to \mathbb{A}^1 via the second projection. For $Z \subset X$, we fix an isomorphism $Z \cong \mathfrak{Y}_c$ so that $u|_Z \cong \phi_{k,c}$; we specify $v_1, v_2 \in Z$ so that $u(v_i) \in D_i$; we let X_0 be the closure of $X - Z$ in X .

We now glue \mathfrak{Y} onto $X_0 \times \mathbb{A}^1$. In case both v_1 and v_2 are nodes of X , we glue \mathfrak{Y} onto $X_0 \times \mathbb{A}^1$ by identifying \mathfrak{D}_1 with $v_1 \times \mathbb{A}^1$ and \mathfrak{D}_2 with $v_2 \times \mathbb{A}^1$, using their standard isomorphisms with \mathbb{A}^1 ; in case v_1 is a marked point of X and v_2 is a node, we glue \mathfrak{Y} onto $X_0 \times \mathbb{A}^1$ by identifying \mathfrak{D}_2 with $v_2 \times \mathbb{A}^1$ and declaring \mathfrak{D}_1 to be the new marked points, replacing v_1 ; in case v_1 is a node and v_2 is a marked point, we repeat the same procedure with the role of v_1 and v_2 and of \mathfrak{D}_1 and \mathfrak{D}_2 exchanged; finally in case both v_1 and v_2 are marked points, we simply replace $Z \times \mathbb{A}^1$ in $X \times \mathbb{A}^1$ by \mathfrak{Y} while declaring that \mathfrak{D}_1 and \mathfrak{D}_2 are the two marked points replacing v_1 and v_2 . We let $\mathcal{X} \rightarrow \mathbb{A}^1$ be the resulting family.

The morphisms

$$X_0 \times \mathbb{A}^1 \xrightarrow{\text{pr}} X_0 \xrightarrow{u|_{X_0}} W[\mathbf{m}] \quad \text{and} \quad \Phi_k: \mathfrak{Y} \longrightarrow W$$

glue together to form a morphism

$$\mathcal{U}: \mathcal{X} \longrightarrow W[\mathbf{m}].$$

The pair $(\mathcal{U}, \mathcal{X})$ is the family in $\mathcal{M}_{\text{def}}^{T_n}$ that keeps $u|_{X_0}$ fixed.

More generally, we can deform u inside $\mathcal{M}_{\text{def}}^{T_n}$ by identifying and altering its restriction to the deformable parts of X simultaneously. This way, any $u \in \mathcal{M}_{\text{def}}^{T_n}$ of type $(k_i)_l$ generates an \mathbb{A}^l family of elements in $\mathcal{M}_{\text{def}}^{T_n}$.

5.4 Global structure of the loci of invariant relative morphisms

In this subsection, we shall prove that any connected component of $\mathcal{M}_{\text{def}}^{T_n}$ is an \mathbb{A}^l -bundle.

We begin with a technical lemma:

Lemma 5.10 *Let $v \in X_{\text{node}}$ be a node in $u^{-1}(D)$. Then v remains a node when u deforms infinitesimally in $\mathcal{M}_{\text{def}}^{T_\eta}$.*

The key to the proof is that the T_η actions on the two irreducible components of X that contain v are infinite on one and trivial on the other.

Recall that there is a natural inclusion $h: T \rightarrow \text{Aut}(W[\mathbf{m}])$ induced by the T -actions on W and on $N_{D_i/W}$. There is a unique homomorphism $h': T \rightarrow \text{Aut}(W[\mathbf{m}]/W)$ such that³ $h'(t) \circ h(t) \in \text{Aut}(W[\mathbf{m}])$ act trivially on $p_i[m_i]$ for all $t \in T$, where $p_i[m_i]$ is the fiber of $\Delta[m_i]$ over $p_i \in D_i$. Since u is G -invariant and the image $u(u^{-1}(\Delta[m_i]))$ is entirely contained in $p_i[m_i]$, there is a group homomorphism $h_1: T_\eta \rightarrow \text{Aut}(X)$ such that for all $\sigma \in T_\eta$,

$$h'(\sigma) \circ h(\sigma) \circ u = u \circ h_1(\sigma) \quad \text{and} \quad h_1(\sigma) \text{ acts on } u^{-1}(\Delta[m_i]) \text{ trivially.}$$

Now let $v \in u^{-1}(D_i)$ be a node of X that is mapped to D_i under u ; let V_- be the irreducible component of X that contains v that is mapped to W , and let V_+ be the other irreducible component of X that contains v . Then $u(V_+)$ must be contained in $\Delta[m_i]$. Since $h_1(\text{id}) = \text{id}$ and that T_η is connected, $h_1(\sigma)(V_\pm) \subset V_\pm$. Hence $h_1(\sigma)$ are automorphisms of V_\pm that fix v . We let

$$T_\eta|_{V_\pm} \stackrel{\text{def}}{=} \{h_1(\sigma) \mid \sigma \in T_\eta\} \subset \text{Aut}(V_\pm, v);$$

it is a group which is a homomorphism image of $G \cong \mathbb{C}^*$, so it is either \mathbb{C}^* or trivial.

Lemma 5.11 *The group $G|_{V_-}$ is infinite while the group $G|_{V_+}$ is trivial. Therefore $G|_{V_-} \cong \mathbb{C}^*$.*

Proof Since $h_1(\sigma)$ acts trivially on $u^{-1}(\Delta[m_i]) \supset V_+$, $G|_{V_+}$ is trivial.

Since $u(v) = p_i$ and $u(V_-) \subset W$, $u(V_-)$ is T_η invariant but not T_η fixed. The induced action on $u(V_-)$ is infinite, so $T_\eta|_{V_-}$ must be infinite because u is T_η -invariant. \square

We now prove Lemma 5.10.

Proof of Lemma 5.10 Suppose the node v can be smoothed of first order within $\mathcal{M}_{\text{def}}^{T_\eta}$, then there is a family of stable morphisms u_B over $B = \text{Spec } \mathbb{C}[t]/(t^2)$ in $\mathcal{M}_{\text{def}}^{T_\eta}$ such that its closed fiber is u and that the family of the domain curves smoothes the node v to the first order. We let X_B be the domain of u_B . Since the closed fiber of X_B

³The automorphisms $\zeta \in \text{Aut}(W[\mathbf{m}])$ that preserve the fibers of the map $W[\mathbf{m}] \rightarrow W$ are called relative automorphisms of $W[\mathbf{m}]/W$; the group of all such automorphisms is denoted by $\text{Aut}(W[\mathbf{m}]/W)$. If $\mathbf{m} = (m_1, m_2, m_3)$ then $\text{Aut}(W[\mathbf{m}]/W) \cong (\mathbb{C}^*)^{m_1+m_2+m_3}$.

is X , v is a closed point of X_B . And since X_B smoothes the node v to the first order, the tangent space $T_v X_B$ is \mathbb{C}^2 . On the other hand, $\Pi(T_\eta)$ is fixed by T_η , the family $X_B \rightarrow B$ is T_η -equivariant with T_η acts trivially on B . Therefore, the T_η action on $T_v X_B$ leaves $T_v V_+$ and $T_v V_-$ invariant and has opposite weights on $T_v V_+$ and $T_v V_-$. This contradicts to that $T_\eta|_{V_-}$ is infinite while $T_\eta|_{V_+}$ is trivial. This proves the lemma. \square

As we argued before, each $u \in \mathcal{M}_{\text{def}}^{T_\eta}$ contains a deformable part that is the union of some ϕ_{k_i, c_i} . Our next task is to show that the deformable parts of u remain the same within a connected component of $\mathcal{M}_{\text{def}}^{T_\eta}$.

We now make it more precise. We let (u, X) be any element in $\mathcal{M}_{\text{def}}^{T_\eta}$; let $Y_1, \dots, Y_l \subset X$ be all its deformable parts so that $u|_{Y_i} \cong \phi_{k_i, c_i}$; let $v_{i,1}$ and $v_{i,2} \in Y_i$ be the marked points so that $u(v_{i,j}) = p_j$. According to the discussion in the previous Subsection, by varying $u|_{Y_i}$ using Φ_{k_i} we get a copy \mathbb{A}^1 in $\mathcal{M}_{\text{def}}^{T_\eta}$; by varying all the deformable parts we obtain a copy \mathbb{A}^l in $\mathcal{M}_{\text{def}}^{T_\eta}$. This is the fiber of the fiber bundle structure on $\mathcal{M}_{\text{def}}^{T_\eta}$ we are about to construct.

To extend this $\mathbb{A}^l \subset \mathcal{M}_{\text{def}}^{T_\eta}$ to nearby elements of $[u]$, we need to extend all Y_i in X to a flat family of subcurves.

Lemma 5.12 *The deformation type function on $\mathcal{M}_{\text{def}}^{T_\eta}$ is locally constant.*

Proof We pick a smooth curve $0 \in S$ and a morphism $\psi: S \rightarrow \mathcal{M}_{\text{def}}^{T_\eta}$ so that $\psi(0) = [u]$. The morphism ψ pulls back the tautological family on $\mathcal{M}_{\text{def}}^{T_\eta}$ to a family $\mathcal{X}: \mathcal{X} \rightarrow \mathcal{W}$ over S . The central fiber \mathcal{X}_0 is X and thus contains Y_i . We let $\mathcal{N} \subset \mathcal{X}$ be the subscheme of the nodes of all fibers of \mathcal{X}/S . As before, we let $\mathcal{R} \subset \mathcal{X}$ be the divisor of special marked points in the domain \mathcal{X} . Since $v_{i,j}$ is either a marked point or a node of X , $v_{i,j} \in \mathcal{N} \cup \mathcal{R}$. Let $\mathcal{P}_{i,j}$ be the connected component of $\mathcal{N} \cup \mathcal{R}$ that contains $v_{i,j}$. We claim that $\mathcal{P}_{i,j}$ is a section of $\mathcal{N} \cup \mathcal{R} \rightarrow S$. First, $\mathcal{P}_{i,j}$ is flat over S at $v_{i,j}$. This is true in case $v_{i,j}$ is a marked point since \mathcal{R} is flat over S by definition; in case $v_{i,j}$ is a node, it is true because of Lemma 5.10. Therefore, $\mathcal{P}_{i,j}$ dominates S . Then because $\mathcal{N} \cup \mathcal{R}$ is proper and unramified over S , dominating over S guarantees that $\mathcal{P}_{i,j}$ is finite and étale over S . Replacing S by its étale cover, we can assume that $\mathcal{P}_{i,j}$ is isomorphic to S via the projection.

We now pick the desired family of curves \mathcal{Y}_i . For $j = 1$ or 2 , in case $\mathcal{P}_{i,j}$ is one of the sections of the marked points of \mathcal{X}/S , we do nothing; otherwise, we resolve the singularity of the fibers of \mathcal{X} along $\mathcal{P}_{i,j}$. As a result, we obtain a flat family of subcurves $\mathcal{Y}_i \subset \mathcal{X}$ that contains Y_i as its central fiber. We let $\mathcal{U}_i: \mathcal{Y}_i \rightarrow \mathcal{W}$ be the restriction of \mathcal{U} to \mathcal{Y}_i . Because $\mathcal{U}_i(Y_i) \subset W \subset W[\mathbf{m}]$, $\mathcal{U}_i(\mathcal{Y}_i) \subset W \times S \subset \mathcal{W}$ as well.

Since $\mathcal{U}: \mathcal{X} \rightarrow \mathcal{W}$ is a family of T_η -equivariant relative stable maps, $\mathcal{U}_i: \mathcal{Y}_i \rightarrow W$ is also a family of T_η -equivariant stable morphisms. Then because $\mathcal{U}_i|_{\mathcal{Y}_i}$ is isomorphic to ϕ_{k_i, c_i} , each member of \mathcal{U}_i must be an $\phi_{k_i, c}$ for some $c \in \mathbb{C}$. This proves that the deformation type of $\mathcal{U}|_{\mathcal{X}_s}$ contains that of $\mathcal{U}|_{\mathcal{X}_0}$ as a subset. Because this holds true with 0 and s exchanged, it shows that the deformation type function remains constant over S .

Finally, because any two elements in the same connected component of $\mathcal{M}_{\text{def}}^{T_\eta}$ can be connected by a chain of images of smooth curves, the deformation type function takes same values on such component. This proves the lemma. \square

We are now ready to exhibit a fiber bundle structure of any connected component of $\mathcal{M}_{\text{def}}^{T_\eta}$. Let $\mathcal{Q} \subset \mathcal{M}_{\text{def}}^{T_\eta}$ be any connected component. We know that all elements in \mathcal{Q} are of the same deformation type, say $(k_i)_I$. To get the fiber structure, we need to take a finite cover of \mathcal{Q} .

Definition 5.13 We define the groupoid $\bar{\mathcal{Q}}$ over \mathcal{Q} as follows. For any scheme S over \mathcal{Q} , we let $\bar{\mathcal{Q}}(S)$ be the collection of data $\{(\mathcal{U}, \mathcal{X}, \mathcal{W}), \rho_i, \mathcal{Z}_i, \pi_i \mid i = 1 \cdots, l\}$ of which

- (1) $\mathcal{U}: \mathcal{X} \rightarrow \mathcal{W}$ is an object⁴ in $\mathcal{Q}(S)$;
- (2) ρ_i are morphisms from S to \mathbb{A}_i^1 , $\mathbb{A}_i^1 \cong \mathbb{A}^1$;
- (3) \mathcal{Z}_i are flat families of subcurves in \mathcal{X} over S with all marked points discarded;
- (4) $\pi_i: \mathcal{Z}_i \rightarrow \rho_i^* \mathfrak{Y}_{k_i}$ is an isomorphism over S ;

together they satisfy

$$\mathcal{U}|_{\mathcal{Z}_i} \equiv \rho_i^* \Phi_{k_i} \circ \pi_i: \mathcal{Z}_i \longrightarrow W.$$

Further, an arrow from $\{(\mathcal{U}, \mathcal{X}, \mathcal{W}), \rho_i, \mathcal{Z}_i, \pi_i\}$ to $\{(\mathcal{U}', \mathcal{X}', \mathcal{W}'), \rho'_i, \mathcal{Z}'_i, \pi'_i\}$ consists of an isomorphism $h_1: \mathcal{X} \rightarrow \mathcal{X}'$ and an isomorphism $h_2: \mathcal{W} \rightarrow \mathcal{W}'$ relative to W so that under these isomorphisms $\mathcal{Z}_i = \mathcal{Z}'_i$, $\rho_i = \rho'_i$, $\pi_i = \pi'_i$ (for all $i = 1, \dots, l$) and $\mathcal{U} = \mathcal{U}'$.

Here we use \mathbb{A}_i^1 to denote the target of ρ_i , which is \mathbb{A}^1 . We are doing this to distinguish them for different i .

For a fixed type $(k_i)_I$, we form a subgroup of the symmetry group S_I :

$$G_{(k_i)_I} = \{\sigma \in S_I \mid k_{\sigma(i)} = k_i\}.$$

⁴Here we consider \mathcal{Q} as a groupoid and $\mathcal{Q}(S)$ is the collection of objects over S .

Proposition 5.14 *The groupoid $\bar{\mathcal{Q}}$ is a DM-stack acted on by $G_{(k_i)_l}$; it is finite and étale over \mathcal{Q} , and $\bar{\mathcal{Q}}/G_{(k_i)_l} = \mathcal{Q}$. The morphisms ρ_l in each object in $\bar{\mathcal{Q}}$ glue to a morphism $\bar{\rho}_l: \bar{\mathcal{Q}} \rightarrow \mathbb{A}^1_l$. Let $\bar{\mathcal{Q}}_0 = (\bar{\rho}_1, \dots, \bar{\rho}_l)^{-1}(0)$. Then there is a canonical projection $\pi: \bar{\mathcal{Q}} \rightarrow \bar{\mathcal{Q}}_0$ making it an \mathbb{A}^l -bundle over $\bar{\mathcal{Q}}_0$. Finally, the morphism*

$$(\pi, (\bar{\rho}_1, \dots, \bar{\rho}_l)): \bar{\mathcal{Q}} \longrightarrow \bar{\mathcal{Q}}_0 \times \mathbb{A}^l$$

is an isomorphism of DM-stacks.

Proof We shall omit the proof, which is straightforward, by the previous discussion. \square

5.5 The obstruction sheaves

In this subsection, we will investigate the obstruction sheaf to deforming a $[u]$ in $\mathcal{M}_{\text{def}}^{T_\eta}$ for the case $a_2, a_3 < 0$. We will construct weight zero quotient trivial sheaves (meaning $\cong \mathcal{O}$) of these obstruction sheaves. It is these quotient sheaves that allow us to prove the desired vanishing in equivariant Chow groups.

We will follow the convention introduced in Section 5.4. We let $S \rightarrow \bar{\mathcal{Q}}$ be a T -equivariant étale neighborhood, and let

$$\mathcal{U}: \mathcal{X} \longrightarrow \mathcal{W}, \quad \mathcal{R} \subset \mathcal{X}, \quad \mathcal{D} \subset \mathcal{W} \quad \text{and} \quad \mathcal{Z}_\iota \subset \mathcal{X}$$

be the tautological family of $\mathcal{M}_{\text{def}}^{T_\eta}$ over S . Here \mathcal{W} is an S -family of $W[\mathbf{m}]$ of possibly varying \mathbf{m} , \mathcal{D} is the relative divisor of \mathcal{W} , $\mathcal{R} \subset \mathcal{X}$ is the union of the sections of marked points and $\mathcal{Z}_\iota \subset \mathcal{X}$ is the ι -th deformable parts of \mathcal{U} .

Let \mathcal{T}^2 be the obstruction sheaf over S of the obstruction theory of $\mathcal{M}_{\text{def}}^{T_\eta}$. According to [20, Proposition 5.1], its T_η -invariant part, indicated by the subscript $(\cdot)_{T_\eta}$, fits into the long exact sequences:

$$(5-5) \quad \longrightarrow \mathcal{E}xt^1_{\mathcal{X}/S}(\Omega_{\mathcal{X}/S}(\mathcal{R}), \mathcal{O}_{\mathcal{X}})_{T_\eta} \xrightarrow{\beta} \mathcal{A}^1_{T_\eta} \xrightarrow{\delta} \tilde{\mathcal{T}}^2_{T_\eta} \longrightarrow 0$$

$$(5-6) \quad \longrightarrow \mathcal{B}^0_{T_\eta} \longrightarrow R^1 \pi_* (\mathcal{U}^* \Omega_{\mathcal{W}^\dagger/S}(\log \mathcal{D})^\vee)_{T_\eta} \xrightarrow{\alpha} \mathcal{A}^1_{T_\eta} \longrightarrow \mathcal{B}^1_{T_\eta} \longrightarrow 0$$

$$(5-7) \quad \longrightarrow \tilde{\mathcal{T}}^1_{T_\eta} \longrightarrow \mathcal{H}_{T_\eta} \longrightarrow \mathcal{T}^2_{T_\eta} \longrightarrow \tilde{\mathcal{T}}^2_{T_\eta} \longrightarrow 0.$$

Within these sequences, $\mathcal{B}^j = \bigoplus_{i=1}^3 \mathcal{B}^j_i$; each summand \mathcal{B}^j_i is a sheaf that associates to the smoothing of the nodes of the fibers of \mathcal{X} that are mapped under \mathcal{U} to \mathcal{D} ($\subset \mathcal{W}$) or the singular loci of $\Delta[m_i]$; the \mathcal{W}^\dagger is the scheme \mathcal{W} with the log structure defined in [20, Section 1.1] and $\Omega_{\mathcal{W}^\dagger}$ is the sheaf of log differentials. In our case, $\mathcal{U}^* \Omega_{\mathcal{W}^\dagger/S}(\mathcal{D}) = \tilde{\mathcal{U}}^* \Omega_{\mathcal{W}}(\log \mathcal{D})$, where $\tilde{\mathcal{U}}: \mathcal{X} \rightarrow \mathcal{W}$ is the obvious induced morphism.

Without taking the T_η -invariant part, the top two exact sequences define the obstruction sheaf $\tilde{\mathcal{T}}^2$ to deforming $[u]$ in $\mathcal{M}_{\mathcal{X}, \vec{d}, \vec{\mu}}^\bullet(W^{\text{rel}})$ —the moduli of relative stable morphisms

to W^{rel} without requiring $u(R) \subset L$. Taking the invariant part and adding the last exact sequence defines the obstruction sheaf $\mathcal{T}_{T_\eta}^2$ of $\mathcal{M}_{\text{def}}^{T_\eta}$. The sheaf \mathcal{H} is the pull back of the normal line bundle to $\mathcal{L} \subset \mathcal{D}$. For the η we are interested, $\mathcal{H}_{T_\eta} = 0$; hence the last exact sequence reduces to $\mathcal{T}_{T_\eta}^2 \cong \tilde{\mathcal{T}}_{T_\eta}^2$.

In the following we shall show that the l families $\mathcal{Z}_l \subset \mathcal{X}$ of deformable parts of $(\mathcal{U}, \mathcal{X})$ each contributes to a weight zero trivial (meaning $\cong \mathcal{O}$) quotient sheaf of $\mathcal{T}_{T_\eta}^2$.

We begin with the sheaf

$$(5-8) \quad R^1 \pi_{0*}(\Phi_{k_l}^* \Omega_W(\log D)^\vee),$$

where $\Phi_{k_l}: \mathfrak{Y} \rightarrow W$ is the family constructed before and $\pi_0: \mathfrak{Y} \rightarrow \mathbb{A}^1$ is the projection. We let D_{12} (resp. D_{31}) be the T -invariant divisor of W that contains C_1 and C_2 (resp. C_1 and C_3); it is also the proper transform of the product of the first and second (resp. the first and third) copies of \mathbb{P}^1 in $(\mathbb{P}^1)^3$. We let $\pi_{12}: W \rightarrow D_{12}$, $\pi_{31}: W \rightarrow D_{31}$ and $\pi_1: W \rightarrow C_1$ be the obvious projections. We claim that $\Omega_W(\log D)|_{D_{12}}$ has a direct summand $\pi_1^* \mathcal{N}_{C_1/D_{31}}^\vee$, the pull back of the conormal bundle to C_1 in D_{31} .

Indeed, via the projection π_{31} we have a homomorphism

$$\pi_{31}^* \mathcal{N}_{C_1/D_{31}}^\vee|_{D_{12}} \longrightarrow \Omega_W|_{D_{12}} \longrightarrow \Omega_W(\log D)|_{D_{12}}.$$

Also via the projection π_{12} we have a homomorphism

$$\pi_{12}^* \Omega_{D_{12}}(\log E_{12})|_{D_{12}} \longrightarrow \Omega_W(\log D)|_{D_{12}}, \quad E_{12} = D_{12} \cap D.$$

Combined, we have

$$\pi_{31}^* \mathcal{N}_{C_1/D_{31}}^\vee|_{D_{12}} \oplus \pi_{12}^* \Omega_{D_{12}}(\log E_{12})|_{D_{12}} \longrightarrow \Omega_W(\log D)|_{D_{12}},$$

which can easily be shown an isomorphism. This proves that $\Omega_W(\log D)|_{D_{12}}$ has a direct summand $\pi_1^* \mathcal{N}_{C_1/D_{31}}^\vee$. Consequently, $\Phi_{k_l}^* \Omega_W(\log D)^\vee$ has a direct summand $\Phi_{k_l}^*(\pi_1^* \mathcal{N}_{C_1/D_{31}})$.

Because of our choice, the weight of dz_i is a_i ; the weight of $T_0^\vee \mathfrak{Y}_c$ is $1/k_l$ and the weight of $\Phi_{k_l}^*(\pi_1^* \mathcal{N}_{C_1/D_{31}})$ at $0 \times \mathbb{A}^1 \subset \mathfrak{Y}$ is $-a_3$. Hence, the sheaf (5-8) splits into line bundles of weights

$$-a_3 - a_1 + \frac{1}{k_l}, -a_3 - a_1 + \frac{2}{k_l}, \dots, -a_3 - \frac{1}{k_l}.$$

Since all a_i are integers, and $a_3 \leq -1$ and $-a_3 - a_1 = a_2 \leq -1$, within the above list there is exactly one that is zero. Hence

$$(5-9) \quad R^1 \pi_{0*}(\Phi_{k_l}^* \Omega_W(\log D)^\vee)_{T_\eta} \cong \mathcal{O}_{\mathbb{A}^1}.$$

We now let $\rho_l: S \rightarrow \mathbb{A}_l^1$ be so that $\mathcal{U}|_{\mathcal{Z}_l} \cong \rho_l^* \Phi_{k_l}$. Since $\mathcal{Z}_l \subset \mathcal{X}$ is a flat family of subcurves,

$$R^1 \pi_* (\mathcal{U}^* \Omega_{\mathcal{W}^\dagger/S} (\log \mathcal{D})^\vee)_{T_\eta} \longrightarrow R^1 \pi_* (\mathcal{U}^* \Omega_{\mathcal{W}^\dagger/S} (\log \mathcal{D})^\vee|_{\mathcal{Z}_l})_{T_\eta}$$

is surjective; but the last term is isomorphic to the pull back ρ_α^* of (5-9); hence we obtain a quotient sheaf

$$(5-10) \quad \varphi_l: R^1 \pi_* (\mathcal{U}^* \Omega_{\mathcal{W}^\dagger/S} (\log \mathcal{D})^\vee)_{T_\eta} \longrightarrow \rho_l^* \mathcal{O}_{\mathbb{A}_l^1}.$$

Lemma 5.15 *The homomorphism φ_l canonically lifts to surjective*

$$(5-11) \quad \hat{\varphi}_l: T_{T_\eta}^2 \longrightarrow \rho_l^* \mathcal{O}_{\mathbb{A}_l^1}.$$

The default proof is to follow the construction of the sheaves and the exact sequences in (5-5)–(5-7); once it is done, the required vanishing will follow immediately. However, to follow this strategy, we need to set up the notation as in [20] that itself requires a lot of efforts. Instead, we will utilize the decomposition of S to give a more conceptual argument; bypassing some straightforward but tedious checking.

We first decompose \mathcal{U} into four subfamilies. Since \mathcal{W}/S is a family of expanded pairs of (W, D) , $\mathcal{W}^{[0]} = W \times S$ is a closed subscheme of \mathcal{W} . We then let $\mathcal{X}^{[0]} = \mathcal{U}^{-1}(\mathcal{W}^{[0]})$. Because of Lemma 5.10,

$$\mathcal{U}^{[0]} = \mathcal{U}|_{\mathcal{X}^{[0]}}: \mathcal{X}^{[0]} \longrightarrow \mathcal{W}^{[0]}$$

is an S -family of relative stable morphisms relative to $\mathcal{D}^{[0]} = D \times S \subset \mathcal{W}^{[0]}$. Next we consider the composite

$$\tilde{\mathcal{U}}: \mathcal{X} \longrightarrow \mathcal{W} \longrightarrow \mathcal{W}^{[0]}$$

and the preimage $\tilde{\mathcal{U}}^{-1}(D_i)$. Because of the same reason, either this preimage is a flat family of nodes over S or is a flat family of curves over S . In the former case we agree $\mathcal{X}^{[i]} = \emptyset$; in the later case we define

$$\mathcal{X}^{[i]} = \tilde{\mathcal{U}}^{-1}(D_i \times S), \quad \mathcal{U}^{[i]} = \mathcal{U}|_{\mathcal{X}^{[i]}}: \mathcal{X}^{[i]} \longrightarrow \mathcal{W}^{[i]},$$

where the last term $\mathcal{W}^{[i]}$ is the S -family of $\Delta[m_i]$'s that are attached to $\mathcal{W}^{[0]}$ along $D_i \times S$ to form \mathcal{W} .

Since $\mathcal{U}^{[0]}: \mathcal{X}^{[0]} \rightarrow \mathcal{W}^{[0]}$ is a family of T_η -equivariant relative stable morphisms, and since $\mathcal{U}^{[i]}$ is a family of T_η -equivariant relative stable morphisms to Δ relative to D_- and D_+ , modulo an additional equivalence induced by the \mathbb{C}^* action on Δ ,

the obstruction sheaves $\mathcal{T}^{[i],2}$ to deforming $\mathcal{U}^{[i]}$ as T_η -equivariant maps ($\mathcal{T}^{[i],2}$ are sheaves over S) fit into similar exact sequences:

$$(5-12) \quad \longrightarrow \mathcal{E}xt_{\mathcal{X}^{[i]}/S}^1(\Omega_{\mathcal{X}^{[i]}/S}(\mathcal{R}^{[i]}), \mathcal{O}_{\mathcal{X}^{[i]}})_{T_\eta} \xrightarrow{\beta^{[i]}} \mathcal{A}_{T_\eta}^{[i],1} \xrightarrow{\delta^{[i]}} \mathcal{T}_{T_\eta}^{[i],2} \longrightarrow 0,$$

$$(5-13) \quad \longrightarrow \mathcal{B}_{T_\eta}^{[i],0} \longrightarrow R^1\pi_*(\mathcal{U}^{[i]*}\Omega_{\mathcal{W}^{[i]}/S}(\log \mathcal{D})^\vee)_{T_\eta} \xrightarrow{\alpha^{[i]}} \mathcal{A}_{T_\eta}^{[i],1} \longrightarrow \mathcal{B}_{T_\eta}^{[i],1} \longrightarrow 0.$$

Here we have already used the observation that $\tilde{\mathcal{T}}_{T_\eta}^{[i],2} = \mathcal{T}_{T_\eta}^{[i],2}$.

Now let $\mathcal{N}_{\text{sp}} \subset \mathcal{U}^{-1}(D_i \times S)$ be any section of nodes of \mathcal{X} that separates $\mathcal{X}^{[0]}$ and $\mathcal{X}^{[i]}$. By Lemma 5.11, the induced T_η -automorphisms on the connected component of $\mathcal{X}^{[0]}$ adjacent to \mathcal{N}_{sp} is infinite and on $\mathcal{X}^{[i]}$ is finite. Therefore the T_η -invariant parts

$$\mathcal{E}xt_{\mathcal{X}/S}^1(\Omega_{\mathcal{X}/S}(\mathcal{R}), \mathcal{O}_{\mathcal{X}})_{T_\eta} = \bigoplus_{i=0}^3 \mathcal{E}xt_{\mathcal{X}^{[i]}/S}^1(\Omega_{\mathcal{X}^{[i]}/S}(\mathcal{R}^{[i]}), \mathcal{O}_{\mathcal{X}^{[i]}})_{T_\eta}.$$

For the same reason, because the tangent bundle $T_{p_i}W$ has no weight zero nontrivial T_η -invariant subspaces,

$$(5-14) \quad R^1\pi_*(\mathcal{U}^*\Omega_{\mathcal{W}^+/S}(\log \mathcal{D})^\vee)_{T_\eta} = \bigoplus_{i=0}^3 R^1\pi_*(\mathcal{U}^{[i]*}\Omega_{\mathcal{W}^{[i]}/S}(\log \mathcal{D}^{[i]})^\vee)_{T_\eta},$$

where $\mathcal{D}^{[i]}$ is the relative divisor of $\mathcal{W}^{[i]}$. Further, if we follow the definition of the sheaves \mathcal{B}^i and \mathcal{A}^i , we can prove that

$$\bigoplus_{i=0}^3 \mathcal{A}_{T_\eta}^{[i],j} = \mathcal{A}_{T_\eta}^j \quad \text{and} \quad \bigoplus_{i=0}^3 \mathcal{B}_{T_\eta}^{[i],j} = \mathcal{B}_{T_\eta}^j;$$

that under these isomorphisms,

$$\bigoplus_{i=0}^3 \alpha^{[i]} = \alpha, \quad \bigoplus_{i=0}^3 \beta^{[i]} = \beta \quad \text{and} \quad \bigoplus_{i=0}^3 \delta^{[i]} = \delta;$$

and

$$(5-15) \quad \bigoplus_{i=0}^3 \mathcal{T}_{T_\eta}^{[i],2} = \mathcal{T}_{T_\eta}^2.$$

Finally, the exact sequences (5-5) and (5-6) become the direct sums of the exact sequences (5-12) and (5-13).

Now we come back to the weight zero quotient φ_i in (5-10). By its construction, φ_i is merely the canonical quotient homomorphism

$$(5-16) \quad R^1 \pi_* (\mathcal{U}^{[0]*} \Omega_{\mathcal{W}^{[0]}/S} (\log \mathcal{D}^{[0]})^\vee)_{T_\eta} \longrightarrow R^1 \pi_* (\mathcal{U}^{[0]*} \Omega_{\mathcal{W}^{[0]}/S} (\log \mathcal{D}^{[0]})^\vee|_{\mathcal{Z}_i})_{T_\eta} = \rho_i^* \mathcal{O}_{\mathbb{A}_i^1}$$

under the isomorphism (5-14). Because of (5-15), to lift φ_i to $\hat{\varphi}_i$ we only need to lift (5-16) to $T_{T_\eta}^{[0],2} \rightarrow \rho_i^* \mathcal{O}_{\mathbb{A}_i^1}$.

For this, we need to look at the exact sequence (5-13) for $\mathcal{X}^{[0]}$. Since $\mathcal{U}^{[0]}$ is a relative stable map to (W, D) , namely no Δ has been attached to W , the sheaf $\mathcal{B}^{[0],j} = 0$. Therefore the sequence (5-13) reduces to $\alpha^{[0]} = \text{id}$. On the other hand, $T_{T_\eta}^{[0],2}$ is the obstruction sheaf on S to deformations of $\mathcal{U}^{[0]}$. Since \mathcal{Z}_i is a family of connected components of $\mathcal{X}^{[0]}/S$, the exact sequence (5-12) decomposes into direct sum of exact sequences that contains

$$(5-17) \quad \longrightarrow \mathcal{E}xt_{\mathcal{Z}_i/S}^1 (\Omega_{\mathcal{Z}_i/S} (\mathcal{R}^{[0]}), \mathcal{O}_{\mathcal{Z}_i})_{T_\eta} \xrightarrow{\beta^{[\mathcal{Z}_i]}} \longrightarrow R^1 \pi_* (\mathcal{U}^{[0]*} \Omega_{\mathcal{W}^+/S} (\log \mathcal{D})^\vee|_{\mathcal{Z}_i})_{T_\eta} \xrightarrow{\delta^{[\mathcal{Z}_i]}} T_{T_\eta}^{[\mathcal{Z}_i],2} \longrightarrow 0$$

as their factors.

For \mathcal{Z}_i , since it is smooth, it has expected dimension zero and has actual dimension one, the obstruction sheaf $T_{T_\eta}^{[\mathcal{Z}_i],2}$ must be a rank one locally free sheaf on S . Then because the middle term in (5-17) is $\rho_i^* \mathcal{O}_{\mathbb{A}_i^1}$, which is a rank one locally free sheaf, the arrow $\delta^{[\mathcal{Z}_i]}$ must be an isomorphism while $\beta^{[\mathcal{Z}_i]} = 0$. Hence φ_i lifts to

$$T_{T_\eta}^{[0],2} \equiv \bigoplus_{\gamma} T_{T_\eta}^{[\mathcal{Z}_\gamma],2} \longrightarrow T_{T_\eta}^{[\mathcal{Z}_i],2} \equiv \rho_i^* \mathcal{O}_{\mathbb{A}_i^1},$$

and lifts to $\hat{\varphi}_i: T_{T_\eta}^2 \rightarrow \rho_i^* \mathcal{O}_{\mathbb{A}_i^1}$, thanks to (5-15).

5.6 The case for $\eta = (1, -1, 0)$

We now investigate the structures of maps $[u] \in \mathcal{M}_{\text{def}}^{T_\eta}$ in case $\eta = (1, -1, 0)$. Let (u, X) be any such map, let $R \subset X$ be the divisor of marked points and let \tilde{u} be the contraction $X \rightarrow W$. Because $a_3 = 0$, $\tilde{u}(X)$ intersects D_1 at p_1 ; it intersects D_3 at p_3 ; its intersection with D_2 can be any point in L_2 . Thus being T_η -equivariant forces $\tilde{u}(X)$ to be a finite union of a subset of C_1, C_2, C_3 and the lifts to W of the sets $\{z_1 z_2 = c, z_3 = 0\} \subset (\mathbb{P}^1)^3$.

In case all irreducible components are mapped to $\cup C_i$ under \tilde{u} , $[u] \in \Xi_1$. For those that are not in Ξ_1 , there are some $Z \subset X$ so that $\tilde{u}(Z)$ are the lifts of $\{z_1 z_2 = c, z_3 = 0\}$.

Such $u|_Z$ are realized by the morphisms $\phi_{k,c}: \mathbb{P}^1 \rightarrow W$ that are the lifts of

$$\xi \mapsto (c^k \xi^k, \xi^{-k}, 0) \in (\mathbb{P}^1)^3.$$

When c specializes to 0, the maps $\phi_{k,c}$ specialize to the $\phi_{k,0}: \mathbb{P}^1 \sqcup \mathbb{P}^1 \rightarrow W$ that is the lift of $\xi_1 \mapsto (\xi_1^k, 0, 0)$ and $\xi_2 \mapsto (0, \xi_2^{-k}, 0)$. Indeed, there is a family $\mathfrak{Y} \rightarrow \mathbb{A}^1$ and a morphism $\Phi_k: \mathfrak{Y} \rightarrow W$ so that its fiber over $c \in \mathbb{A}^1$ is the $\phi_{k,c}$ defined; also this is a complete list of T_η -equivariant deformations of $\phi_{k,c}$. Since the argument is exactly the same as in the prior case studied, we shall not repeat it here.

Here comes the main difference between this and the case studied earlier. In the previous case, $\text{Im } \phi_{k,c} \cap D_i = p_i$ for both $i = 1$ and 2 ; hence we can deform each $u|_Z \cong \phi_{k,c}$ to produce an \mathbb{A}^1 family in $\mathcal{M}_{\text{def}}^{T_\eta}$. In the case under consideration, though $\text{Im } \phi_{k,c} \cap D_1 = p_1$, if we fix an embedding $\mathbb{A}^1 \subset L_2$ so that $0 \in \mathbb{A}^1$ is the $p_2 \in L_2$, then $\text{Im } \phi_{k,c} \cap D_2 = c^k \in L_2$. In other words, if we deform $u|_F \cong \phi_{k,c}$, we need to move the connected component of $X^{[2]}$ that is connected to Y . (Recall that for $u: X \rightarrow W[\mathbf{m}]$, $X^{[i]} = u^{-1}(\Delta[m_i])$ for $1 \leq i \leq 3$ and $X^{[0]} = u^{-1}(W)$.)

This leads to the following definition.

Definition 5.16 We say that a connected component $Z \subset X^{[0]}$ is subordinated to a connected component $E \subset X^{[2]}$ if $Z \cap E \neq \emptyset$; we say a connected component $E \subset X^{[2]}$ is deformable if every connected component of $X^{[0]}$ that is subordinate to E is of the form $\phi_{k,c}$ for some pair (k, c) . We say u has deformation type $(k_i)_l = (k_1 \leq \dots \leq k_l)$ if it has exactly l deformable connected components $\phi_{k_1, c_1}, \dots, \phi_{k_l, c_l}$ in $X^{[2]}$.

The deformation types define a function on $\mathcal{M}_{\text{def}}^{T_\eta}$.

Lemma 5.17 *The deformation type function is locally constant on $\mathcal{M}_{\text{def}}^{T_\eta}$.*

Proof The proof is parallel to the case studied previously, and will be omitted. \square

As in the previous case, any $[u] \in \mathcal{M}_{\text{def}}^{T_\eta}$ of deformation type $(k_i)_l$ generates an \mathbb{A}^1 in $\mathcal{M}_{\text{def}}^{T_\eta}$ so that its origin lies in Ξ_1 . Let $E_1, \dots, E_l \subset X^{[2]}$ be the complete set of deformable parts of u ; let $Z_{i,j}$, $j = 1, \dots, n_i$ be the complete set of connected components in $X^{[0]}$ that are subordinate to E_i . By definition, each $u|_{Z_{i,j}} \cong \phi_{k_{i,j}, c_{i,j}}$. To deform u , we shall vary the $c_{i,j}$ in each $\phi_{k_{i,j}, c_{i,j}}$ and move E_i accordingly to get a new map.

In accordance, we shall divide X into three parts. We let X_0 be the union of irreducible components of X other than the E_i 's and $Z_{i,j}$'s. The variation of u will remain unchanged over this part of the curve. The second part is the moving part E_i 's. Recall

that each $u|_{E_\iota}$ is a morphism to $\Delta[m_2]$. Suppose it maps to the fiber $\Delta[m_2]_c$ of $\Delta[m_2]$ over $c \in L_2 \subset D_2$. To deform u , we need to make the new map mapping E_ι to $\Delta[m_2]_{c'}$. Since the total space of $\Delta[m_2]$ over L_2 is a trivial $\mathbb{P}^1[m_2]$ bundle, there is a canonical way to do this. We let

$$\varphi_{c,c'}: \Delta[m_2]_c \xrightarrow{\cong} \Delta[m_2]_{c'}$$

be the isomorphism of the two fibers of $\Delta[m_2]$ over c and $c' \in L_2$ induced by the projection $\Delta[m_2] \rightarrow \mathbb{P}^1[m_2]$ that is induced by the product structure on $\Delta[m_2]$ over L_2 . The third parts are those $Z_{\iota,j}$ that are subordinate to E_ι .

We now deform the map u using the parameter space \mathbb{A}^l . We let K_ι be the least common multiple of $(k_{\iota,1}, \dots, k_{\iota,n_\iota})$; we let $e_{\iota,j} = K_\iota/k_{\iota,j}$. Since $Z_{\iota,j}$ and $Z_{\iota,j'}$ are connected to the same connected component $E_\alpha \subset X^{[2]}$,

$$c_{\iota,j}^{k_{\iota,j}} = c_{\iota,j'}^{k_{\iota,j'}};$$

we let it be c_ι . For $\mathbf{t} = (t_1, \dots, t_l) \in \mathbb{A}^l$, we define

$$u^\mathbf{t}|_{X_0} = u|_{X_0}, \quad u^\mathbf{t}|_{E_\iota} = \varphi_{c_\iota, t_\iota}^{K_\iota} \circ u|_{E_\iota} \quad \text{and} \quad u^\mathbf{t}|_{Z_{\iota,j}} = \phi_{k_{\iota,j}, t_\iota}^{e_{\iota,j}}.$$

Here by $u^\mathbf{t}|_{Z_{\iota,j}} = \phi_{k_{\iota,j}, 0}$ in case $Z_{\iota,j} \cong \mathbb{P}^1$ (when $c_{\iota,j} \neq 0$) we mean that we will replace $Z_{\iota,j}$ by $\mathbb{P}^1 \sqcup \mathbb{P}^1$ with necessarily gluing if required; and vice versa.

The \mathbb{A}^l family $u^\mathbf{t}$ is a family of T_η -equivariant relative stable morphisms in $\mathcal{M}_{\text{def}}^{T_\eta}$; the map u^0 associated to $0 \in \mathbb{A}^l$ lies in Ξ_1 ; the induced morphism $\mathbb{A}^l \rightarrow \mathcal{M}_{\text{def}}^{T_\eta}$ is an embedding up to a finite quotient.

By extending this to any connected component \mathcal{Q} of $\mathcal{M}_{\text{def}}^{T_\eta}$, we obtain:

Proposition 5.18 *Let \mathcal{Q} be any connected component of $\mathcal{M}_{\text{def}}^{T_\eta}$ that is not entirely contained in Ξ_1 . Suppose elements of \mathcal{Q} has deformation type $(k_\iota)_l$. Then there is a stack $\bar{\mathcal{Q}}$, a finite quotient morphism $\bar{\mathcal{Q}}/G_{(k_\iota)_l} \rightarrow \mathcal{Q}$, a closed substack $\bar{\mathcal{Q}}_0 \subset \bar{\mathcal{Q}}$, l projections $\rho_\iota: \bar{\mathcal{Q}} \rightarrow \mathbb{A}^1$ and a projection $\pi: \bar{\mathcal{Q}} \rightarrow \bar{\mathcal{Q}}_0$ so that*

$$(\pi, (\rho_1, \dots, \rho_l)): \bar{\mathcal{Q}} \xrightarrow{\cong} \bar{\mathcal{Q}}_0 \times \mathbb{A}^l$$

is an isomorphism. Further, given a $[u] \in \mathcal{Q}$, the fiber \mathbb{A}^l in $\bar{\mathcal{Q}}$ that contains a lift of $[u] \in \mathcal{Q}$ is the \mathbb{A}^l family $\{u^\mathbf{t} \mid \mathbf{t} \in \mathbb{A}^l\}$; its intersection with the zero section $\bar{\mathcal{Q}}_0$ is u^0 . Finally, the intersection $\mathcal{Q} \cap \Xi_1$ is the image of $\bar{\mathcal{Q}}_0$.

Proof Let $\mathcal{U}: \mathcal{X} \rightarrow \mathcal{W}$ be the tautological family over $\bar{\mathcal{Q}}$. We choose $\bar{\mathcal{Q}}$ so that there are families of subcurves $\mathcal{E}_1, \dots, \mathcal{E}_l \subset \mathcal{X}$ so that for each $z \in \bar{\mathcal{Q}}$, $\mathcal{E}_1 \cap \mathcal{X}_z, \dots, \mathcal{E}_l \cap \mathcal{X}_z$ are exactly the l deformable parts of \mathcal{X}_z . Then the composite $\mathcal{E}_\iota \rightarrow \mathcal{W} \rightarrow W$ factor

through $L_2 \subset W$, and the resulting morphism $\mathcal{E}_l \rightarrow L_2$ factor through $\bar{\mathcal{Q}} \rightarrow L_2$. Because each $\mathcal{E}_l \cap \mathcal{X}_z$ has a $\phi_{k,c}$ connected to it, the image of $\bar{\mathcal{Q}} \rightarrow L_2$ lies in $L_2 - q_2$. We then fix an isomorphism $\mathbb{A}^1 \cong L_2 - q_2$ with 0 corresponding to p_2 . This way we obtain the desired morphism

$$\rho_l: \bar{\mathcal{Q}} \longrightarrow \mathbb{A}^1 \cong L_2 - q_2.$$

The proof of the remainder part of the Proposition is exactly the same as the case studied; we shall not repeat it here. \square

The last step is to investigate the obstruction sheaf over \mathcal{Q} and its lift to $\bar{\mathcal{Q}}$.

Let $\mathcal{R} \subset \mathcal{X}$ be the divisor of marked points. By passing to an étale covering of $\bar{\mathcal{Q}}$, we can assume that $\mathcal{R} \rightarrow \bar{\mathcal{Q}}$ is a union of sections; in other words, we can index the marked points of $[u]$ in $\bar{\mathcal{Q}}$ globally. We then pick an indexing so that for $\iota \leq l$ the ι -th section of the marked points \mathcal{R}_ι lies in \mathcal{E}_ι . For $\iota = 1, \dots, n$, where n is the number of marked points, we let $\mathcal{U}_\iota: \bar{\mathcal{Q}} \rightarrow \mathcal{L}_2$ be

$$\mathcal{U}_\iota \stackrel{\text{def}}{=} \mathcal{U}|_{\mathcal{R}_\iota}: \mathcal{R}_\iota \cong \bar{\mathcal{Q}} \longrightarrow \mathcal{L}_2 \subset \mathcal{W}.$$

Since $\mathcal{L}_2 \subset \mathcal{D}_2$ is isomorphic to $L_2 \times \bar{\mathcal{Q}} \subset D_2 \times \bar{\mathcal{Q}}$ under the contraction $\mathcal{W} \rightarrow W \times \bar{\mathcal{Q}}$ and since \mathcal{R}_ι lies in \mathcal{E}_ι , for $\alpha \leq l$ the morphism \mathcal{U}_ι is exactly the ρ_ι under the isomorphism $\mathbb{A}^1 \cong L_2 - q_2$, and $\mathcal{U}_\iota^* \mathcal{N}_{\mathcal{L}/\mathcal{D}}$ is canonically isomorphic to $\rho_\iota^* N_{L_2/D_2}$. Because D_2 is fixed by T_η , N_{L_2/D_2} is fixed as well, and hence $\rho_\iota^* N_{L_2/D_2}$ is a trivial line bundle on $\bar{\mathcal{Q}}$ with trivial T_η -linearization.

Because $\mathcal{H} = \bigoplus_{\iota=1}^n \mathcal{U}_\iota^* \mathcal{N}_{\mathcal{L}/\mathcal{D}}$ (see Section 5.5), $\bigoplus_{\iota=1}^l \rho_\iota^* N_{L_2/D_2}$ becomes a direct summand of \mathcal{H} . Because it has weight zero, it induces a canonical homomorphism

$$\bigoplus_{\iota=1}^l \rho_\iota^* N_{L_2/D_2} \longrightarrow \mathcal{T}_{T_\eta}^2,$$

a weight zero subsheaf of $\mathcal{T}_{T_\eta}^2$.

Lemma 5.19 *The homomorphism $\bigoplus_{\iota=1}^l \rho_\iota^* N_{L_2/D_2} \rightarrow \mathcal{T}_{T_\eta}^2$ in (5-7) is injective, and is a direct summand of $\mathcal{T}_{T_\eta}^2$.*

Proof First the first l marked points lie in the connected components of $X^{[2]}$ that are connected to the domain of at least one $\phi_{k,c}$ in W . Because all deformations of $\phi_{k,c}$ as T_η -invariant maps are $\phi_{k,c'}$, and they intersect D_2 in L_2 only; hence for these ι even if we do not impose the condition $\mathcal{U}(\mathcal{R}_\iota) \subset \mathcal{L}_2$ the condition will be satisfied automatically. In short, the arrow $\tilde{\mathcal{T}}_{T_\eta}^1 \rightarrow \mathcal{H}_{T_\eta}$ has image lying in the summand

$\bigoplus_{i=l+1}^n \mathcal{U}_i^* \mathcal{N}_{L/D}$. This proves that the homomorphism $\bigoplus_{i=1}^l \rho_i^* N_{L_2/D_2} \rightarrow \mathcal{T}_{T_\eta}^2$ is injective.

We now show that this subsheaf is canonically a summand of the obstruction sheaf. The ordinary moduli of stable relative morphisms $\mathcal{M}_{\chi, \vec{d}, \vec{\mu}}^\bullet(W^{\text{rel}})$ requires that the marked points be sent to the relative divisor. The moduli space $\Xi = \mathcal{M}_{\chi, \vec{d}, \vec{\mu}}^\bullet(W^{\text{rel}}, L)$ imposes one more restriction: the marked points be sent to $L \subset D$. The obstruction sheaves of the two moduli spaces are related by the exact sequence (5-7) because of the exact sequences

$$0 \longrightarrow N_{L_i/D_i} \longrightarrow N_{L_i/W} \longrightarrow N_{D_i/W}|_{L_i} \longrightarrow 0.$$

In our case, L_i is a \mathbb{P}^1 and the above exact sequence splits T -equivariantly. Hence the sheaf $\mathcal{T}_{T_\eta}^2$ splits off a factor that is the cokernel of $\tilde{\mathcal{T}}_{T_\eta}^1 \rightarrow \mathcal{H}_{T_\eta}$. Therefore $\bigoplus_{i=1}^l \rho_i^* N_{L_2/D_2}$, which is a summand of \mathcal{H}_{T_η} and a subsheaf of $\mathcal{T}_{T_\eta}^2$, becomes a summand of $\mathcal{T}_{T_\eta}^2$. \square

5.7 Proof of Theorem 4.8

Before presenting the proof, a quick review of the construction of the virtual cycles of moduli stacks is in order.

Let $T = (\mathbb{C}^*)^2$ and Ξ be as before. As shown in [3; 4; 21], the virtual cycle $[\Xi]^{\text{vir}}$ is constructed by

- (a) identifying the perfect obstruction theory of Ξ ;
- (b) picking a vector bundle⁵ (locally free sheaf) E on Ξ so that it surjects onto the obstruction sheaf of Ξ ;
- (c) constructing an associated cone $C \subset E$ of pure dimension $\text{rank } E$.

The virtual cycle $[\Xi]^{\text{vir}}$ is the image of the cycle $[C] \in H_{2r}(E, E - \Xi)$ under the Thom isomorphism

$$\varphi_E: H_{2r}(E, E - \Xi) \longrightarrow H_0(\Xi), \quad r = \text{rank } E.$$

Here as usual, we denote by E the total space of E and denote by $\Xi \subset E$ its zero section that is isomorphic to Ξ . Also, all homologies are taken with \mathbb{Q} -coefficient. And $\varphi_E[C] \in H_0$ because Ξ has virtual dimension zero.

Following [11], we can make the above construction T -equivariant. We choose E be a T -equivariant vector bundle. Then the cone C alluded before is a T -invariant subcone of E . Because $C \subset E$ is T -equivariant, the limiting class of

$$[C \times_{T_{\mathbb{R}}} B^l T_{\mathbb{R}}] \in H_{2r+4l}(E \times_{T_{\mathbb{R}}} B^l T_{\mathbb{R}})$$

⁵It was shown in [20] the existence of a global vector bundle E can be replaced by that Ξ is dominated by a quasi-projective scheme.

defines a T -equivariant $[C]^T \in H_{2r}^T(E, E - \Xi)$; its image under the T -equivariant Thom isomorphism φ_E is the T -equivariant virtual moduli cycle

$$\varphi_E([C]^T) = [\Xi]^{\text{vir}, T} \in H_0^T(\Xi).$$

We now prove that the class $[\Xi]^{\text{vir}, T}$ can be lifted to $H_0^T(\Xi_1 \cup \Xi_2)$. Since U is disjoint from Ξ^T , elements in U have stabilizers of at most dimension one. Clearly, the set of those with finite stabilizers, denoted by U_0 , is open in U . Those with one dimensional stabilizers form a closed subset of U . By the conclusions from the previous two sections, each of its connected component is a connected component of $\Pi(G)$ for some one-dimensional $G \subset T$. As before we denote such connected components by Q_a , indexed by a set $a \in A$, namely

$$U = U_0 \cup \bigcup_{a \in A} Q_a.$$

Also, for each $a \in A$, it associates to a subgroup $G_a \subset T$ so that Q_a is a connected component of $\Pi(G_a)$.

As G_a is a subgroup of T , it associates to a triple of relatively prime integers (a_1, a_2, a_3) . To streamline the discussion, we remark that we only need to consider two cases:

- (1) $a_1, -a_2$ and $-a_3$ are positive;
- (2) $(a_1, a_2, a_3) = (1, -1, 0)$.

Indeed, since the symmetry of $(\mathbb{P}^1)^3$ defined by $(z_1, z_2, z_3) \mapsto (z_2, z_3, z_1)$ lifts to a symmetry of W , any statement that holds true for (a_1, a_2, a_3) holds true for (a_2, a_3, a_1) . Consequently, we only need to work with the cases that $|a_1| \geq |a_2|$ and $|a_3|$. Then because (a_1, a_2, a_3) and $(-a_1, -a_2, -a_3)$ define the same subgroup $G \subset T$, we can assume further that $a_1 > 0$. Hence either a_2 and $a_3 < 0$ or one of them is zero. The former is case (1); for later, by applying the S_3 symmetry we can reduce it to case (2).

We now suppose that $T_{\eta_a} \subset T$ belongs to the two classes just mentioned. We let Q_a be a connected component of $\Pi(G_a)$ associated to U_a . According to Lemmas 5.14 and 5.18, after a finite branched covering $\pi_a: \bar{Q}_a \rightarrow Q_a$, \bar{Q}_a is isomorphic to $Q_{a,0} \times \mathbb{A}^l$ for some integer $l > 0$.

Next, we need to investigate the T -action on \bar{Q}_a . Since \bar{Q}_a is fixed by G_a and is invariant under T , the T -action on it is determined by the action of a $G_0 = \mathbb{C}^* \subset T$ complement to G_a . Since the list of $G_a \subset T$ appeared in this construction is finite, we can pick such a G_0 so that $G_0 \cdot G_a = T$ for all $G_a \subset T$. By going through the

construction, we see immediately that the G_0 -action on \bar{Q}_a is the product of the action on $\bar{Q}_{a,0}$ induced by that on Ξ_1 and the action

$$(5-18) \quad (u_1, \dots, u_l)^\sigma = (\sigma^{w_1} u_1, \dots, \sigma^{w_l} u_l) \in \mathbb{A}^l$$

for some $\mathbf{w} = (w_1, \dots, w_l)$, where $w_i \in \mathbb{Q}^*$. In case some w_i are nonintegers, we let d be the least common multiple of the denominators of all w_i and replace the G_0 action by composing it with the degree d homomorphism $G_0 \rightarrow G_0$. This way the new exponents are dw_i , which are integers. Thus without loss of generality, we can assume that all w_i are integers in the first place. Hence if we let $P_a: \bar{Q}_a \rightarrow \mathbb{A}^l$ be the projection, which is (ρ_1, \dots, ρ_l) by our convention, and if we endow \mathbb{A}^l with the G_0 -action (5-18), then $\bar{Q}_a \rightarrow \mathbb{A}^l$ is G_0 -equivariant.

We can quotient the pair $\bar{Q}_a \rightarrow \mathbb{A}^l$ by G_0 now. We let $\bar{Q}_{a,0} \subset \bar{Q}_a$ be the union of fibers over Ξ^T , which by our previous study is exactly the preimage $P_a^{-1}(0)$. Accordingly, we let $(\mathbb{A}^l)^* = \mathbb{A}^l - 0$ and form

$$\mu_a: M_a \stackrel{\text{def}}{=} (\bar{Q}_a - \bar{Q}_{a,0})/G_0 \longrightarrow (\mathbb{A}^l)^*/G_0 = \mathbb{P}_{\mathbf{w}}^{l-1}.$$

Here we use the subscript \mathbf{w} to indicate the weights and the superscript $l - 1$ to denote the dimension of the weighted projective space; to be precise, we shall view the weighted projective space as a DM-stack. Since the specific weight is irrelevant to our study, we shall not keep track of it in our study.

We next put our prior knowledge of the invariant part of the obstruction sheaf of Q_a in this setting. We let \mathcal{T}_a^2 be the obstruction sheaf on \bar{Q} and let $\mathcal{T}_{a,T_{\eta_a}}^2$ be its invariant part. By Lemmas 5.15 and 5.19, there is a canonical quotient sheaf homomorphism

$$(5-19) \quad \mathcal{T}_{a,T_{\eta_a}}^2 \longrightarrow \bigoplus_{\iota=1}^l \rho_\iota^* \mathcal{O}_{\mathbb{A}^1_\iota},$$

both with trivial T_{η_a} -actions.

A direct check shows that to each ι there is a G_0 -linearization on $\mathcal{O}_{\mathbb{A}^1_\iota}$ so that the above homomorphism is G_0 -equivariant. Because $G_0 \cdot G_a = T$, the adopted G_0 -linearization and the trivial G_a -linearization on $\mathcal{O}_{\mathbb{A}^1_\iota}$ makes (5-19) T -equivariant.

Since the obstruction sheaf \mathcal{T}^2 on Ξ is a T -equivariant quotient sheaf of E , pulling back to \bar{Q}_a , denoting it by $E|_{\bar{Q}_a}$, and then composing with (5-19) give us a T -equivariant quotient sheaf

$$(5-20) \quad E|_{\bar{Q}_a} \longrightarrow \bigoplus_{\iota=1}^l \rho_\iota^* \mathcal{O}_{\mathbb{A}^1_\iota}.$$

Their descents to M_a then give us a vector bundle F_a over M_a and a quotient homomorphism

$$F_a \longrightarrow \mu_a^* \mathcal{V}_a.$$

Here \mathcal{V}_a is the descent (or the G_0 -quotient) of $\bigoplus_{i=1}^l \mathcal{O}_{\mathbb{A}^1_i}$ —a rank l vector bundle on $\mathbb{P}_{\mathbb{w}}^{l-1}$ with trivial T -action; F_a is the descent of E , a vector bundle over M_a .

We need a key technical lemma recently proved in [15, Lemma 2.6] concerning the cone $C \subset E$ and its restriction to \mathcal{Q}_a .

Lemma 5.20 [15] *Let $C|_{\mathcal{Q}_a} \subset E|_{\mathcal{Q}_a}$ be the restriction of $C \subset E$ to \mathcal{Q}_a ; let $C|_{\bar{\mathcal{Q}}_a} \subset E|_{\bar{\mathcal{Q}}_a}$ be the pull back of $C|_{\mathcal{Q}_a}$ to $\bar{\mathcal{Q}}_a$. Then $C|_{\bar{\mathcal{Q}}_a}$ lies in the kernel bundle of the homomorphism (5-20).*

Before we prove Theorem 4.8, we need to recall the convention we shall adopt in dealing with Ξ using analytic method. We now work with the analytic category in the remainder of this section. By viewing Ξ as an orbifold, every point $x \in \Xi$ is covered by charts

$$p_\alpha: x_\alpha \in V_\alpha \longrightarrow x \in V_\alpha/H_\alpha \subset \Xi,$$

where V_α are (possibly singular) analytic spaces acted on by finite groups H_α . For two charts V_β and V_α over the same $p_\alpha(V_\alpha) = p_\beta(V_\beta)$, we say V_β is over V_α if there is a group homomorphism $H_\beta \rightarrow H_\alpha$ and an H_β -equivariant map $\phi_{\alpha\beta}: V_\beta \rightarrow V_\alpha$ commuting with the projections p_α and p_β . We say $x_\beta \in V_\beta$ is over $x_\alpha \in V_\alpha$ if in addition we have $\phi_{\beta\alpha}(x_\beta) = x_\alpha$.

Since Ξ is an orbifold, it is covered by charts defined, and for any two charts $x_\alpha \in V_\alpha$ and $x_\beta \in V_\beta$ of $x \in \Xi$, there is a third chart $x_\gamma \in V_\gamma$ of $x \in \Xi$ that is over both $x_\alpha \in V_\alpha$ and $x_\beta \in V_\beta$.

The vector bundle $E \rightarrow \Xi$ pulls back to H_α -equivariant vector bundles E_α on V_α . To define Gysin map with \mathbb{Q} -coefficients, we can use \mathbb{Q} -sections⁶ of E , which are collections of compatible \mathbb{Q} -sections on a covering charts of Ξ .

Proof of Theorem 4.8 We first argue that we can find a $T_{\mathbb{R}}$ -equivariant \mathbb{Q} -section of E over U that is disjoint from the cone $C|_U \subset E|_U$.

⁶A \mathbb{Q} -section of $E|_{V_\alpha/H_\alpha}$ is an H_α -invariant weighted union of C^∞ -sections of E_α : $[s] = \sum a_i [s_i]$ with $a_i \in \mathbb{Q}_{\geq 0}$, $\sum a_i = 1$ and s_i are sections of E_α . The sum of $[s]$ with $[s'] = \sum a'_i [s'_i]$ is $[s] + [s'] = \sum a_i a'_j [s_i + s'_j]$. Here each $[s_i]$ is viewed as a subset of V_α with multiplicity one. We can scale a section $[s]$ by a smooth function ρ on V_α/H_α (or a H_α -invariant function on V_α) by $[\rho s] = \sum a_i [\rho s_i]$. To extend the section $[s]$, we can first extend each s_i individually and then averaging using H_α to make it H_α -invariant. Two \mathbb{Q} -sections over V_α and V_β are equal over a third chart V_γ over V_α and V_β if the pull back of the two sections to V_γ are identical.

We will construct the desired section of $E|_U$ by first constructing sections of $E|_{Q_a^-}$ and then extend them to U . Since we will be content with \mathbb{Q} -section, we can construct such section over $\bar{Q}_a^- = \pi_a^{-1}(Q_a^-)$. We let

$$\xi_a: \bar{Q}_a^- \longrightarrow M_a \quad \text{and} \quad E|_{\bar{Q}_a^-} \longrightarrow \xi_a^* F_a \longrightarrow \xi_a^* \mu_a^* \mathcal{V}_a$$

be the tautological map constructed before Lemma 5.20.

Since \mathcal{V}_a is a rank l (orbi)bundle on a \mathbb{P}_w^{l-1} , the rank $l > \dim \mathbb{P}_w^{l-1}$ guarantees that there are \mathbb{Q} -sections $[s_a]$ of \mathcal{V}_a that is disjoint from the zero section of \mathcal{V}_a . We now pick an analytic $T_{\mathbb{R}}$ -equivariant splitting of $E|_{\bar{Q}_a^-}$ so that

$$E|_{\bar{Q}_a^-} = \xi_a^* \mu_a^* \mathcal{V}_a \oplus E^\perp|_{\bar{Q}_a^-}$$

Such splitting exists if we pick a $T_{\mathbb{R}}$ -invariant hermitian metric on E . Using this splitting, we can lift the sections $[s_a]$ of \mathcal{V}_a to a \mathbb{Q} -section of E over \bar{Q}_a^- . By pushing this section to Q_a^- , we obtain a \mathbb{Q} -section of E over Q_a^- . By working over all Q_a^- , we obtain a \mathbb{Q} -section on $\cup_{a \in A} Q_a^-$. We denote this section by $[s]_{\mathbb{Q}}$. By Lemma 5.20, $[s]_{\mathbb{Q}}$ is disjoint from the restriction of the cone $C \subset E$ to Q_a^- for all $a \in A$.

Next, since $\cup_{a \in A} Q_a^-$ is closed in U , we can extend $[s]_{\mathbb{Q}}$ to a $T_{\mathbb{R}}$ -invariant \mathbb{Q} -section $[s]_{\mathbb{Q}}^{\text{ex}}$ of E in a $T_{\mathbb{R}}$ -invariant neighborhood of $\cup_{a \in A} Q_a^- \subset U$. We denote this neighborhood by V :

$$U \supset V \supset \cup_{a \in A} Q_a^-.$$

Since $[s]_{\mathbb{Q}}$ is disjoint with the cone $C \subset E$, by choosing V small, we can assume that the extension $[s]_{\mathbb{Q}}^{\text{ex}}$ remains disjoint with the cone $C \subset E$.

Finally, we need to extend $[s]_{\mathbb{Q}}^{\text{ex}}$ to over U . This time, since elements in U_0 have finite stabilizers in $T_{\mathbb{R}}$,

$$\underline{U}_0 = U_0/T_{\mathbb{R}} \quad \text{and} \quad \underline{E} = E|_{U_0}/T_{\mathbb{R}},$$

are an orbifold and an orbundle over it. Also, since the restriction of $[s]_{\mathbb{Q}}^{\text{ex}}$ to V is $T_{\mathbb{R}}$ -equivariant, it descends to a \mathbb{Q} -section of \underline{E} over

$$\underline{V} = (V \cap U_0)/T_{\mathbb{R}} \subset \underline{U}_0.$$

We denoted this section by $[s]$. Because the quotient $\underline{C} = C|_{U_0}/T_{\mathbb{R}}$ is a cone of pure \mathbb{R} -dimension $2r - 2$ in \underline{E} , (recall that virtual dimension of \mathfrak{E} is zero means that C has pure complex dimension r .) and because \underline{E} is a rank $2r$ (real) orbundle over \underline{U}_0 , by a generic position argument and possibly after shrinking V if necessary, we can extend $[s]$ to a \mathbb{Q} -section $[s]^{\text{ex}}$ of \underline{E} over \underline{U}_0 so that it is disjoint with the cone \underline{C} . The pull back of $[s]^{\text{ex}}$ over to $E|_{U_0}$ is the desired \mathbb{Q} -section that is $T_{\mathbb{R}}$ -equivariant, is disjoint with the cone $C|_{U_0}$ and is an extension of $[s]_{\mathbb{Q}}$.

Since $[\Xi]^{vir,T} = \varphi_E[C]$, the existence of a $T_{\mathbb{R}}$ -equivariant \mathbb{Q} -section disjoint from $C|_U$ implies that the image $\beta([\Xi]^{vir,T}) = 0$ for β the arrow shown below. By the exact sequence

$$H_0^{T_{\mathbb{R}}}(\Xi - U) \longrightarrow H_0^{T_{\mathbb{R}}}(\Xi) \xrightarrow{\beta} H_0^{T_{\mathbb{R}}}(U) \longrightarrow 0,$$

we see that $[\Xi]^{vir,T}$ lifts to a class in $H_0^{T_{\mathbb{R}}}(\Xi_1 \cup \Xi_2)$ since $\Xi - U = \Xi_1 \cup \Xi_2$. Combined with the comment at the end of Section 5.2 we complete the proof of the theorem. □

6 Topological vertex, Hodge integrals and double Hurwitz numbers

In this section, we will investigate a general topological vertex and compute its formal relative GW-contribution introduced in (4-5). According to its definition (Definition 5.1), the topological vertex $\Gamma_{\mathbf{n};w_1,w_2}$ is a FTCY as in Figure 10, where $\mathbf{n} = (n_1, n_2, n_3) \in \mathbb{Z}^{\oplus 3}$,

$$(6-1) \quad f_1 = w_2 - n_1 w_1, \quad f_2 = w_3 - n_2 w_2, \quad f_3 = w_1 - n_3 w_3, \quad w_3 = -w_1 - w_2;$$

its GW-invariants contribution we denote by

$$(6-2) \quad F_{\chi, \vec{\mu}}^{\bullet}(\mathbf{n}; w_1, w_2) \stackrel{\text{def}}{=} F_{\chi, \vec{d}, \vec{\mu}}^{\bullet \Gamma_{\mathbf{n};w_1,w_2}}(u_1, u_2),$$

where the RHS is defined by (4-5).

To simplify the notation, we will fix $\mathbf{n} = (n_1, n_2, n_3)$ and (w_1, w_2) once and for all and write Γ instead of $\Gamma_{\mathbf{n};w_1,w_2}$.

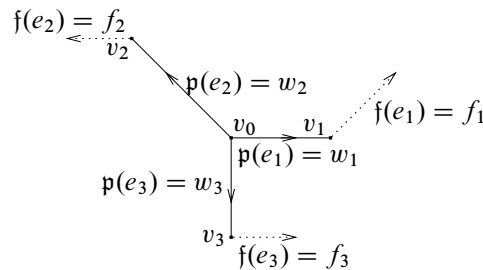

Figure 10: The graph of a topological vertex

6.1 Torus fixed points and label notation

In this subsection, we describe the T -fixed points in $\overline{\mathcal{M}}_{\chi, \bar{\mu}}^\bullet(\Gamma) \stackrel{\text{def}}{=} \overline{\mathcal{M}}_{\chi, \bar{d}, \bar{\mu}}^\bullet(\hat{Y}^{\text{rel}}, \hat{L})$, and introduce the label notation. Such label corresponds to a disjoint union of connected components of

$$\overline{\mathcal{M}}_{\chi, \bar{\mu}}^\bullet(\Gamma)^T = \overline{\mathcal{M}}_{\chi, \bar{\mu}}^\bullet(\Gamma)^{T_{\mathbb{R}}},$$

or equivalently, a collection of graphs in the graph notation.

Let $\hat{Y}^{\text{rel}} = (\hat{Y}, \hat{D})$ be the FTCY associated to Γ , and let

$$\hat{D}^i = \hat{D}^{v_i}, \quad C^i = C^{\bar{e}_i}$$

for $i = 1, 2, 3$. Given $u: (X, \mathbf{q}) \rightarrow (\hat{Y}_{\mathbf{m}}, \hat{D}_{\mathbf{m}})$, which represents a point in $\overline{\mathcal{M}}_{\chi, \bar{\mu}}^\bullet(\Gamma)^T$, we introduce its associated map

$$\tilde{u} = \pi_{\mathbf{m}} \circ u: X \rightarrow \hat{Y}_{\Gamma}^{\text{rel}},$$

where $\pi_{\mathbf{m}}: \hat{Y}_{\mathbf{m}} \rightarrow \hat{Y}$ is the projection defined in Section 4.1. Then $\tilde{u}(X) \subset C^1 \cup C^2 \cup C^3$. Let z^0 and z^i be the two T fixed points on C^i , and let

$$V^i = \tilde{u}^{-1}(z^i), \quad i = 0, 1, 2, 3.$$

We also let E^i be the closure of $\tilde{u}^{-1}(C^i \setminus \{z^0, z^i\})$ for $i = 1, 2, 3$. Then E^i is a union of projective lines, and $u|_{E^i}: E^i \rightarrow C^i$ is a degree $d^i = |\mu^i|$ cover fully ramified over z^0 and z^i .

For $i = 1, 2$ or 3 , we then define

$$\mathbb{P}^i(m^i) = \pi_{\mathbf{m}}^{-1}(z^i),$$

which is a point if $m^i = 0$ and a chain of m^i copies of \mathbb{P}^1 if $m^i > 0$. We let

$$\hat{u}^i = u|_{V^i}: V^i \rightarrow \mathbb{P}^i(m^i), \quad \tilde{u}^i = u|_{E^i}: E^i \rightarrow C^i.$$

The degrees of \tilde{u}^i restricted to connected components of E^i determine a partition v^i of d^i .

For the same i , we let $V_1^i, \dots, V_{k^i}^i$ be the connected components of V^i , and let g_j^i be the arithmetic genus of V_j^i . (We define $g_j^i = 0$ if V_j^i is a point.) We introduce

$$\chi^i = \sum_{j=1}^{k^i} (2 - 2g_j^i).$$

Then

$$-\sum_{i=0}^3 \chi^i + 2 \sum_{i=1}^3 \ell(v^i) = -\chi.$$

Note that $\chi^i \leq 2 \min\{\ell(\mu^i), \ell(v^i)\}$ for $i = 1, 2, 3$, so

$$-\chi^i + \ell(v^i) + \ell(\mu^i) \geq 0$$

and the equality holds if and only if $m^i = 0$. In this case, we have $v^i = \mu^i$ and $\chi^i = 2\ell(\mu^i)$.

We introduce moduli spaces of relative stable maps to the nonrigid $(\mathbb{P}^1, \{0, \infty\})$ (called *rubber* in [30] etc.):

$$\overline{\mathcal{M}}_{\chi, v, \mu}^{\bullet, \sim} \stackrel{\text{def}}{=} \overline{\mathcal{M}}_{\chi}^{\bullet}(\mathbb{P}^1, v, \mu) // \mathbb{C}^*.$$

The quotient $\overline{\mathcal{M}}_{\chi}^{\bullet}(\mathbb{P}^1, v, \mu) // \mathbb{C}^*$ is defined in [23, Section 5].

For each $i \in \{1, 2, 3\}$, there are two possibilities:

Case 1 $m^i = 0$. Then \hat{u}^i is a constant map from $\ell(\mu^i)$ points to p^i .

Case 2 $m^i > 0$. Then \hat{u}^i represents a point in $\overline{\mathcal{M}}_{\chi^i, v^i, \mu^i}^{\bullet, \sim}$.

Definition 6.1 An *admissible label* of $\overline{\mathcal{M}}_{\chi, \vec{\mu}}^{\bullet}(\Gamma)$ is a pair $(\vec{\chi}, \vec{v})$ such that

- (1) $\vec{\chi} = (\chi^0, \chi^1, \chi^2, \chi^3)$, where $\chi^i \in 2\mathbb{Z}$;
- (2) $\vec{v} = (v^1, v^2, v^3)$, where v^i is a partition such that $|v^i| = |\mu^i|$;
- (3) $\chi^0 \leq 2 \sum_{i=1}^3 \ell(v^i)$;
- (4) $\chi^i \leq 2 \min\{\ell(\mu^i), \ell(v^i)\}$ for $i = 1, 2, 3$;
- (5) $-\sum_{i=0}^3 \chi^i + 2 \sum_{i=1}^3 \ell(v^i) = -\chi$.

Let $G_{\chi, \vec{\mu}}^{\bullet}(\Gamma)$ denote the set of all admissible labels of $\overline{\mathcal{M}}_{\chi, \vec{\mu}}^{\bullet}(\Gamma)$.

For a nonnegative integer g and a positive integer h , let $\overline{\mathcal{M}}_{g, h}$ be the moduli space of stable curves of genus g with h marked points. Although $\overline{\mathcal{M}}_{g, h}$ is empty for $(g, h) = (0, 1), (0, 2)$, for notational simplicity, we agree that:

$$\int_{\overline{\mathcal{M}}_{0, 1}} \frac{1}{1 - d\psi} = \frac{1}{d^2}, \quad \int_{\overline{\mathcal{M}}_{0, 2}} \frac{1}{(1 - \mu_1\psi_1)(1 - \mu_2\psi_2)} = \frac{1}{\mu_1 + \mu_2}.$$

This convention will fit in with the general results.

For a nonnegative integer g and a positive integer h , let $\overline{\mathcal{M}}_{\chi, h}^{\bullet}$ be the moduli of possibly disconnected stable curves C with h marked points such that

- if C_1, \dots, C_k are connected components of C and g_i are the arithmetic genus of C_i , then

$$\sum_{i=1}^k (2 - 2g_i) = \chi;$$

- each connected component contains at least one marked point.

The connected components of $\bar{\mathcal{M}}_{\chi, h}^\bullet$ are of the form

$$\bar{\mathcal{M}}_{g_1, h_1} \times \cdots \times \bar{\mathcal{M}}_{g_k, h_k}, \quad \text{where} \quad \sum_{i=1}^k (2 - 2g_i) = \chi, \quad \sum_{i=1}^k h_i = h.$$

The restriction of the Hodge bundle $\mathbb{E} \rightarrow \bar{\mathcal{M}}_{\chi, h}^\bullet$ to the above connected component is the direct sum of the Hodge bundles on each factor; the Hodge integral

$$\Lambda^\vee(u) = \prod_{i=1}^k \Lambda_{g_i}^\vee(u).$$

We define

$$\bar{\mathcal{M}}_{\vec{\chi}, \vec{v}} = \prod_{i=0}^3 \bar{\mathcal{M}}_{\vec{\chi}, \vec{v}}^i,$$

where $\bar{\mathcal{M}}_{\vec{\chi}, \vec{v}}^0 = \bar{\mathcal{M}}_{\chi^0, \ell(\vec{v})}^\bullet$; for $i \in \{1, 2, 3\}$, we define

$$\bar{\mathcal{M}}_{\vec{\chi}, \vec{v}}^i = \begin{cases} \{\text{pt}\}, & -\chi^i + \ell(v^i) + \ell(\mu^i) = 0, \\ \bar{\mathcal{M}}_{\vec{\chi}^i, \vec{v}^i, \mu^i}^\bullet, & -\chi^i + \ell(v^i) + \ell(\mu^i) > 0. \end{cases}$$

For each $(\vec{\chi}, \vec{v}) \in G_{\chi, \vec{\mu}}^\bullet(\Gamma)$, there is a morphism $i_{\vec{\chi}, \vec{v}}: \bar{\mathcal{M}}_{\vec{\chi}, \vec{v}} \rightarrow \bar{\mathcal{M}}_{\chi, \vec{\mu}}^\bullet(\Gamma)^T$ whose image $\mathcal{F}_{\vec{\chi}, \vec{v}}$ is a union of connected components of $\bar{\mathcal{M}}_{\chi, \vec{\mu}}^\bullet(\Gamma)^T$. The morphism $i_{\vec{\chi}, \vec{v}}$ induces an isomorphism

$$\bar{\mathcal{M}}_{\vec{\chi}, \vec{v}} / \left(\prod_{i=1}^3 A_{\vec{\chi}, \vec{v}}^i \right) \cong \mathcal{F}_{\vec{\chi}, \vec{v}},$$

where $A_{\vec{\chi}, \vec{v}}^i$ is the automorphism group associated to the edge e_i :

$$A_{\vec{\chi}, \vec{v}}^i = \prod_{j=1}^{\ell(v^i)} \mathbb{Z}_{v_j^i}, -\chi^i + \ell(v^i) + \ell(\mu^i) = 0;$$

$$1 \rightarrow \prod_{j=1}^{\ell(v^i)} \mathbb{Z}_{v_j^i} \rightarrow A_{\vec{\chi}, \vec{v}}^i \rightarrow \text{Aut}(v^i) \rightarrow 1, -\chi^i + \ell(v^i) + \ell(\mu^i) > 0.$$

The set of fixed points $\bar{\mathcal{M}}_{\chi, \vec{\mu}}^\bullet(\Gamma)^T$ is a disjoint union of

$$\{\mathcal{F}_{\vec{\chi}, \vec{v}} \mid (\vec{\chi}, \vec{v}) \in G_{\chi, \vec{\mu}}^\bullet(\Gamma)\}.$$

Remark 6.2 There are two perfect obstruction theories on $\mathcal{F}_{\vec{\chi}, \vec{v}}$: one is the fixed part $[\mathcal{T}^{1, f} \rightarrow \mathcal{T}^{2, f}]$ of the restriction of the perfect obstruction theory on $\bar{\mathcal{M}}_{\chi, \vec{\mu}}^\bullet(\Gamma)$; the

other comes from the perfect obstruction theory on the moduli spaces $\overline{\mathcal{M}}_{\chi^0, \ell(\vec{v})}^\bullet$ and $\overline{\mathcal{M}}_{\chi^i, v^i, \mu^i}^\bullet$. It is straightforward to check that they coincide.

6.2 Contribution from each label

We view w_i and f_i in Equation (6-1) as elements in

$$\mathbb{Z}u_1 \oplus \mathbb{Z}u_2 = \Lambda_T \cong H_T^2(\text{pt}, \mathbb{Q}).$$

Recall that $H_T^*(\text{pt}; \mathbb{Q}) = \mathbb{Q}[u_1, u_2]$. The results of localization calculations will involve rational functions of w_i and f_i which are elements in $\mathbb{Q}(u_1, u_2)$.

If $m^i > 0$, let ψ_i^0, ψ_i^∞ denote the target ψ class of $\overline{\mathcal{M}}_{\vec{\chi}, \vec{v}}^i$ (see eg [23, Section 5] for definitions). Let $N_{\vec{\chi}, \vec{v}}^{\text{vir}}$ denote the virtual bundle on $\overline{\mathcal{M}}_{\vec{\chi}, \vec{v}}^i$ which is the pull back of $\mathcal{T}^{1,m} - \mathcal{T}^{2,m}$ under $i_{\vec{\chi}, \vec{v}}$.

With the above notation and the explicit description of $[T^1 \rightarrow T^2]$ in Section 4.3, calculations similar to those in [22, Appendix A] show that

$$\frac{1}{e_T(N_{\vec{\chi}, \vec{v}}^{\text{vir}})} = \prod_{i=0}^3 B_{v_i} \prod_{i=1}^3 B_{e_i},$$

where

$$B_{v_0} = \prod_{i=1}^3 \frac{a_{v^i} \Lambda^\vee(w_i) w_i^{\ell(\vec{v})-1}}{\prod_{j=1}^{\ell(v^i)} (w_i (w_i - v_j^i \psi_j^i))}$$

and for $i \in \{1, 2, 3\}$:

$$B_{v_i} = \begin{cases} 1, & -\chi^i + \ell(v^i) + \ell(\mu^i) = 0 \\ (-1)^{\ell(v^i) - \chi^i / 2} a_{v^i} \frac{f_i^{-\chi^i + \ell(v^i) + \ell(\mu^i)}}{-w_i - \psi_i^0}, & -\chi^i + \ell(v^i) + \ell(\mu^i) > 0 \end{cases}$$

$$B_{e_i} = (-1)^{|v^i|n^i + \ell(v^i) - |v^i|} \prod_{j=1}^{\ell(v^i)} \frac{\prod_{a=1}^{v_j^i - 1} (w_{i+1} v_j^i + a w_i)}{(v_j^i - 1)! w_i^{v_j^i - 1}}$$

The disconnected double Hurwitz numbers $H_{\chi, v, \mu}^\bullet$ (see Section 2.2) can be related to intersection of the target ψ class (see [23, Section 5] for a derivation):

$$H_{\chi, v, \mu}^\bullet = \frac{(-\chi + \ell(v) + \ell(\mu))!}{|\text{Aut}(v) \times \text{Aut}(\mu)|} \int_{[\overline{\mathcal{M}}_{\vec{\chi}, \vec{v}, \mu}^\bullet]^{\text{vir}}} (\psi^0)^{-\chi + \ell(v) + \ell(\mu) - 1}$$

The three-partition Hodge integral $G_{\chi, \vec{\mu}}^\bullet(\mathbf{w})$ defined by (2-14) in Section 2.3 can be expressed as

$$G_{\chi, \vec{v}}^\bullet(\mathbf{w}) = (-\sqrt{-1})^{\ell(\vec{v})} V_{\chi, \vec{v}}(\mathbf{w}) \prod_{i=1}^3 E_{v^i}(w_{i+1}, w_i),$$

where

$$(6-3) \quad V_{\chi, \vec{v}}(\mathbf{w}) = \frac{1}{|\text{Aut}(\vec{v})|} \int_{\overline{\mathcal{M}}_{\chi, \ell(\vec{v})}^\bullet} \prod_{i=1}^3 \frac{\Lambda^\vee(w_i) w_i^{\ell(\vec{v})-1}}{\prod_{j=1}^{\ell(v^i)} (w_i(w_i - v_j^i \psi_j^i))},$$

$$(6-4) \quad E_v(x, y) = \prod_{j=1}^{\ell(v)} \frac{\prod_{a=1}^{v_j-1} (y v_j + ax)}{(v_j - 1)! x^{v_j-1}}.$$

We set
$$I_{\vec{\chi}, \vec{v}}(\mathbf{n}; \mathbf{w}) = \int_{[\mathcal{F}_{\vec{\chi}, \vec{v}}]^\text{vir}} \frac{1}{e_T(N_{\vec{\chi}, \vec{v}}^\text{vir})}.$$

Then
$$I_{\vec{\chi}, \vec{v}}(\mathbf{n}; \mathbf{w}) = \frac{1}{\prod_{i=1}^3 |A_{\vec{\chi}, \vec{v}}^i|} \int_{[\overline{\mathcal{M}}_{\vec{\chi}, \vec{v}}]^\text{vir}} \frac{1}{e_T(N_{\vec{\chi}, \vec{v}}^\text{vir})}$$

which equals

$$|\text{Aut}(\vec{\mu})| (-1)^{\sum_{i=1}^3 (n_i-1) |\mu^i|} (-\sqrt{-1})^{\ell(\vec{\mu}) + \ell(\vec{v})} V_{\chi^0, \vec{v}}(\mathbf{w}) \cdot \prod_{i=1}^3 E_{v^i}(w_i, w_{i+1}) z_{v^i} \left(-\sqrt{-1} \frac{f_i}{w_i} \right)^{-\chi^i + \ell(v^i) + \ell(\mu^i)} \frac{H_{\chi^i, v^i, \mu^i}^\bullet}{(-\chi^i + \ell(v^i) + \ell(\mu^i))!}.$$

Therefore,

$$(6-5) \quad I_{\vec{\chi}, \vec{v}}(\mathbf{n}; \mathbf{w}) = |\text{Aut}(\vec{\mu})| (-1)^{\sum_{i=1}^3 (n_i-1) |\mu^i|} (-\sqrt{-1})^{\ell(\vec{\mu})} G_{\chi^0, \vec{v}}^\bullet(\mathbf{w}) \cdot \prod_{i=1}^3 z_{v^i} \left(\sqrt{-1} \left(n_i - \frac{w_{i+1}}{w_i} \right) \right)^{-\chi^i + \ell(v^i) + \ell(\mu^i)} \frac{H_{\chi^i, v^i, \mu^i}^\bullet}{(-\chi^i + \ell(v^i) + \ell(\mu^i))!}.$$

6.3 Sum over labels

The right hand side of (4-5) can be written as a sum of contributions from $\overline{\mathcal{M}}_{\vec{\chi}, \vec{\nu}}$, where $(\vec{\chi}, \vec{\nu}) \in G_{\vec{\chi}, \vec{\mu}}^\bullet(\Gamma)$, so we have

$$F_{\vec{\chi}, \vec{\mu}}^\bullet(\mathbf{n}; w_1, w_2) = \frac{1}{|\text{Aut}(\vec{\mu})|} \sum_{(\vec{\chi}, \vec{\nu}) \in G_{\vec{\chi}, \vec{\mu}}^\bullet(\Gamma)} I_{\vec{\chi}, \vec{\nu}}(\mathbf{n}; \mathbf{w}).$$

We define generating functions

$$\begin{aligned} F_{\vec{\mu}}^\bullet(\lambda; \mathbf{n}; w_1, w_2) &= \sum_{\chi \in 2\mathbb{Z}, \chi \leq \ell(\vec{\mu})} \lambda^{-\chi + \ell(\vec{\mu})} F_{\vec{\chi}, \vec{\mu}}^\bullet(\mathbf{n}; w_1, w_2) \\ (6-6) \quad \tilde{F}_{\vec{\mu}}^\bullet(\lambda; \mathbf{n}; w_1, w_2) &= (-1)^{\sum_{i=1}^3 (n_i - 1)|\mu^i|} \sqrt{-1}^{\ell(\vec{\mu})} F_{\vec{\mu}}^\bullet(\lambda; \mathbf{n}; w_1, w_2). \end{aligned}$$

Then relation (6-5) becomes

$$(6-7) \quad \tilde{F}_{\vec{\mu}}^\bullet(\lambda; \mathbf{n}; w_1, w_2) = \sum_{|\nu^i| = |\mu^i|} G_{\vec{\nu}}^\bullet(\lambda; \mathbf{w}) \prod_{i=1}^3 z_{\nu^i} \Phi_{\nu^i, \mu^i}^\bullet \left(\sqrt{-1} \left(n_i - \frac{w_{i+1}}{w_i} \right) \lambda \right),$$

where $G_{\vec{\mu}}^\bullet(\lambda; \mathbf{w})$ is defined by (2-13) in Section 2.3; $\Phi_{\nu, \mu}^\bullet(\lambda)$ is the generating function of disconnected double Hurwitz numbers defined in Section 2.2.

Equations (6-7), (2-9) and (2-10) imply that

$$(6-8) \quad \tilde{F}_{\vec{\mu}}^\bullet(\lambda; \mathbf{n}; w_1, w_2) = \sum_{|\nu^i| = |\mu^i|} \tilde{F}_{\vec{\nu}}^\bullet(\lambda; \mathbf{0}, w_1, w_2) \prod_{i=1}^3 z_{\nu^i} \Phi_{\nu^i, \mu^i}^\bullet(\sqrt{-1} n_i \lambda).$$

By Theorem 5.2,

$$F_{\vec{\nu}}^\bullet(\lambda; \mathbf{0}; w_1, w_2) = \sum_{\chi} \lambda^{-\chi + \ell(\vec{\nu})} F_{\vec{\chi}, \vec{d}, \vec{\nu}}^{\bullet \Gamma^0}(w_1, w_2)$$

does not depend on w_1, w_2 . So $F_{\vec{\mu}}^\bullet(\lambda; \mathbf{n}; w_1, w_2)$ and $\tilde{F}_{\vec{\mu}}^\bullet(\lambda; \mathbf{n}; w_1, w_2)$ do not depend on w_1, w_2 by (6-6) and (6-8). From now on, we will write

$$F_{\vec{\mu}}^\bullet(\lambda; \mathbf{n}), \quad \tilde{F}_{\vec{\mu}}^\bullet(\lambda; \mathbf{n})$$

instead of $F_{\vec{\mu}}^\bullet(\lambda; \mathbf{n}; w_1, w_2), \tilde{F}_{\vec{\mu}}^\bullet(\lambda; \mathbf{n}; w_1, w_2)$. In summary, for each $\vec{\mu} \in \mathcal{P}_+^3$ and each $\mathbf{n} \in \mathbb{Z}^3$, we have defined a generating function $F_{\vec{\mu}}^\bullet(\lambda; \mathbf{n})$ that are expressed in terms of Hodge integrals and double Hurwitz numbers as follows.

Proposition 6.3 We have

$$(6-9) \quad \tilde{F}_{\vec{\mu}}^{\bullet}(\lambda; \mathbf{n}) = \sum_{|\nu^i|=|\mu^i|} G_{\vec{\nu}}^{\bullet}(\lambda; \mathbf{w}) \prod_{i=1}^3 z_{\nu^i} \Phi_{\nu^i, \mu^i}^{\bullet} \left(\sqrt{-1} \left(n_i - \frac{w_{i+1}}{w_i} \right) \lambda \right).$$

Proposition 6.3 and the sum formula (2-9) of double Hurwitz numbers imply:

Corollary 6.4 (Framing dependence in winding basis) We have

$$(6-10) \quad \tilde{F}_{\vec{\mu}}^{\bullet}(\lambda; \mathbf{n}) = \sum_{|\nu^i|=|\mu^i|} \tilde{F}_{\vec{\nu}}^{\bullet}(\lambda; 0) \prod_{i=1}^3 z_{\nu^i} \Phi_{\nu^i, \mu^i}^{\bullet} \left(\sqrt{-1} n_i \lambda \right).$$

Note that (6-10) is valid for any three complex numbers n_1, n_2, n_3 .

6.4 Representation basis

The framing dependence (6-10) is particularly simple in the representation basis used in [1]. For this, we shall use the notation introduced in Section 2.1. We define

$$(6-11) \quad \tilde{C}_{\vec{\mu}}(\lambda; \mathbf{n}) = \sum_{|\nu^i|=|\mu^i|} \tilde{F}_{\vec{\nu}}^{\bullet}(\lambda; \mathbf{n}) \prod_{i=1}^3 \chi_{\mu^i}(\nu^i),$$

which is equivalent to

$$\tilde{F}_{\vec{\mu}}^{\bullet}(\lambda; \mathbf{n}) = \sum_{|\nu^i|=|\mu^i|} \tilde{C}_{\vec{\nu}}^{\bullet}(\lambda; \mathbf{n}) \prod_{i=1}^3 \frac{\chi_{\nu^i}(\mu^i)}{z_{\mu^i}}.$$

Then (6-10) is equivalent to:

Proposition 6.5 (Framing dependence in representation basis) We have

$$\tilde{C}_{\vec{\mu}}(\lambda; \mathbf{n}) = e^{\frac{1}{2} \sqrt{-1} (\sum_{i=1}^3 \kappa_{\mu^i} n_i) \lambda} \tilde{C}_{\vec{\mu}}(\lambda; \mathbf{0}).$$

We introduce $\tilde{C}_{\vec{\mu}}(\lambda) = \tilde{C}_{\vec{\mu}}(\lambda; \mathbf{0})$ and let $q = e^{\sqrt{-1} \lambda}$, then (6-11), (6-9) and the Burnside formula (2-8) of double Hurwitz numbers imply:

Proposition 6.6 We have

$$(6-12) \quad \tilde{C}_{\vec{\mu}}(\lambda) = q^{-\frac{1}{2}(\sum_{i=1}^3 \kappa_{\mu^i} w_{i+1}/w_i)} \sum_{|v^i|=|\mu^i|} G_{\vec{v}}^{\bullet}(\lambda; \mathbf{w}) \prod_{i=1}^3 \chi_{\mu^i}(v^i),$$

$$(6-13) \quad G_{\vec{\mu}}^{\bullet}(\lambda; \mathbf{w}) = \sum_{|v^i|=|\mu^i|} \prod_{i=1}^3 \frac{\chi_{v^i}(\mu^i)}{z^{\mu^i}} q^{\frac{1}{2}(\sum_{i=1}^3 \kappa_{v^i} w_{i+1}/w_i)} \tilde{C}_{\vec{v}}(\lambda).$$

7 Gluing formulae of formal relative Gromov–Witten invariants

Let Γ be a FTCY graph (see Definition 3.2), and let $(\vec{d}, \vec{\mu})$ be an effective class of Γ (defined in Definition 4.1). In this section, we will calculate the formal relative Gromov–Witten invariant

$$F_{\chi, \vec{d}, \vec{\mu}}^{\bullet \Gamma} (u_1, u_2) \in \mathbb{Q}(u_2/u_1).$$

We will reduce the invariance of $F_{\chi, \vec{d}, \vec{\mu}}^{\bullet \Gamma}$ (Theorem 4.8) to the invariance of the topological vertex at the standard framing (Theorem 5.2). We will derive gluing formulae for such invariants.

As in Definition 4.1, we will use the abbreviation

$$d^{\bar{e}} = \vec{d}(\bar{e}), \quad \bar{e} \in E(\Gamma); \quad \mu^v = \vec{\mu}(v), \quad v \in V_1(\Gamma).$$

7.1 Torus fixed points and label notation

In this subsection, we describe the T -fixed points in $\overline{\mathcal{M}}_{\chi, \vec{d}, \vec{\mu}}^{\bullet}(\hat{Y}^{\text{rel}}, \hat{L})$, and introduce the label notation. This is a generalization of Section 6.1.

Given a morphism

$$u: (X, \mathbf{q}) \longrightarrow (\hat{Y}_{\mathbf{m}}, \hat{D}_{\mathbf{m}}),$$

which represents a point in $\overline{\mathcal{M}}_{\chi, \vec{d}, \vec{\mu}}^{\bullet}(\hat{Y}^{\text{rel}}, \hat{L})^T$, as before we let $\tilde{u} = \pi_{\mathbf{m}} \circ u: X \rightarrow \hat{Y}$. Then

$$\tilde{u}(X) \subset \bigcup_{\bar{e} \in E(\Gamma)} C^{\bar{e}},$$

where $C^{\bar{e}}$ is defined as in Section 3.5.

Let z^v be the T fixed point associated to $v \in V(\Gamma)$, as in Section 3.5, and let

$$V^v = \tilde{u}^{-1}(z^v).$$

Let $E^{\bar{e}}$ be the closure of $\tilde{u}^{-1}(C^{\bar{e}} \setminus \{z^{v_0(e)}, z^{v_1(e)}\})$ for $\bar{e} = \{e, -e\} \in E(\Gamma)$. Then $E^{\bar{e}}$ is a union of projective lines, and $u|_{E^{\bar{e}}}: E^{\bar{e}} \rightarrow C^{\bar{e}}$ is a degree $d^{\bar{e}}$ cover fully ramified over $v_0(e)$ and $v_1(e)$.

For $v \in V_1(\Gamma) \cup V_2(\Gamma)$, we define

$$\mathbb{P}^v(m^v) = \pi_{\mathbf{m}}^{-1}(z^v),$$

which is a point if $m^v = 0$, and is a chain of m^v copies of \mathbb{P}^1 if $m^v > 0$. We let

$$\hat{u}^v = u|_{V^v}: V^v \rightarrow \mathbb{P}^v(m^v).$$

For $\bar{e} \in E(\Gamma)$, we define

$$\tilde{u}^{\bar{e}} = u|_{E^{\bar{e}}}: E^{\bar{e}} \rightarrow C^{\bar{e}}.$$

The degrees of $\tilde{u}^{\bar{e}}$ restricted to connected components of $E^{\bar{e}}$ determine a partition $v^e = v^{-e}$ of $d^{\bar{e}}$.

For $v \in V(\Gamma)$, we let $V_1^v, \dots, V_{k^v}^v$ be the connected components of V^v , and let g_j^v be the arithmetic genus of V_j^v . (We define $g_j^v = 0$ if V_j^v is a point.) We define

$$\chi^v = \sum_{j=1}^{k^v} (2 - 2g_j^v).$$

Then

$$-\sum_{v \in V(\Gamma)} \chi^v + \sum_{e \in E^{\circ}(\Gamma)} \ell(v^e) = -\chi.$$

Given $v \in V_1(\Gamma)$ with $v_1^{-1}(v) = \{e\}$, we have $\chi^v \leq 2 \min\{\ell(v^e), \ell(\mu^v)\}$. Therefore,

$$(7-1) \quad r^v \stackrel{\text{def}}{=} -\chi^v + \ell(v^e) + \ell(\mu^v) \geq 0;$$

the equality holds if and only if $m^v = 0$, and in this case, $v^e = \mu^v$, $\chi^v = 2\ell(\mu^v)$.

For each $v \in V_1(\Gamma)$, there are two cases:

Case 1 $m^v = 0$. Then \hat{u}^v is a constant map from $\ell(\mu^v)$ points to z^v .

Case 2 $m^v > 0$. Then \hat{u}^v represents a point in $\overline{\mathcal{M}}_{\chi^v, v^e, \mu^v}$.

In case $v \in V_2(\Gamma)$ with $v_1^{-1}(v) = \{e, e'\}$, the same conclusions hold. Namely, we have $\chi^v \leq 2 \min\{\ell(v^e), \ell(v^{e'})\}$ and

$$(7-2) \quad r^v \stackrel{\text{def}}{=} -\chi^v + \ell(v^e) + \ell(v^{e'}) \geq 0,$$

and equality holds when the same conclusion as in the case $v \in V_1(\Gamma)$ holds with μ^v replaced by $v^{e'}$.

Definition 7.1 An admissible label of $\bar{\mathcal{M}}_{\chi, \vec{d}, \vec{\mu}}^\bullet(\hat{Y}^{\text{rel}}, \hat{L})$ is a pair $(\vec{\chi}, \vec{v})$ such that:

- (1) $\vec{\chi}: V(\Gamma) \rightarrow 2\mathbb{Z}$. Let χ^v denote $\vec{\chi}(v)$.
- (2) $\vec{v}: E^o(\Gamma) \rightarrow \mathcal{P}$, where $\vec{v}(e) = \vec{v}(-e)$ and $|\vec{v}(e)| = d^{\vec{e}}$. We write v^e for $\vec{v}(e)$.
- (3) For $v \in V_1(\Gamma)$ with $\mathfrak{v}_1^{-1}(v) = \{e\}$, we have $\chi^v \leq 2 \min\{\ell(v^e), \ell(\mu^v)\}$.
- (4) For $v \in V_2(\Gamma)$ with $\mathfrak{v}_1^{-1}(v) = \{e, e'\}$, we have $\chi^v \leq 2 \min\{\ell(v^e), \ell(v^{e'})\}$.
- (5) For $v \in V_3(\Gamma)$, define $\ell_{\vec{v}}(v) = \sum_{e \in \mathfrak{v}_0^{-1}(v)} \ell(v^e)$. Then $\chi^v \leq 2\ell_{\vec{v}}(v)$.
- (6) $-\sum_{v \in V(\Gamma)} \chi^v + 2 \sum_{e \in E(\Gamma)} \ell(v^e) = -\chi$.

We denote by $G_{\chi, \vec{d}, \vec{\mu}}^\bullet(\Gamma)$ the set of all admissible labels of $\bar{\mathcal{M}}_{\chi, \vec{d}, \vec{\mu}}^\bullet(\hat{Y}^{\text{rel}}, \hat{L})$.

Given $(\vec{\chi}, \vec{v}) \in G_{\chi, \vec{d}, \vec{\mu}}^\bullet(\Gamma)$, define r^v as in (7-1) and (7-2) for $v \in V_1(\Gamma)$ and $v \in V_2(\Gamma)$, respectively. We define

$$\bar{\mathcal{M}}_{\vec{\chi}, \vec{v}} = \prod_{v \in V(\Gamma)} \bar{\mathcal{M}}_{\vec{\chi}, \vec{v}}^v$$

where

$$\bar{\mathcal{M}}_{\vec{\chi}, \vec{v}}^v = \begin{cases} \{\text{pt}\}, & v \in V_1(\Gamma) \cup V_2(\Gamma), r^v = 0, \\ \bar{\mathcal{M}}_{\vec{\chi}^v, v^e, \mu^v}^\bullet, & v \in V_1(\Gamma), \mathfrak{v}_1^{-1}(v) = \{e\}, r^v > 0, \\ \bar{\mathcal{M}}_{\vec{\chi}^v, v^e, v^{e'}}^\bullet, & v \in V_2(\Gamma), \mathfrak{v}_1^{-1}(v) = \{e, e'\}, r^v > 0, \\ \bar{\mathcal{M}}_{\vec{\chi}^v, \ell_{\vec{v}}(v)}^\bullet, & v \in V_3(\Gamma). \end{cases}$$

For each $(\vec{\chi}, \vec{v}) \in G_{\chi, \vec{d}, \vec{\mu}}^\bullet(\Gamma)$, there is a morphism

$$i_{\vec{\chi}, \vec{v}}: \bar{\mathcal{M}}_{\vec{\chi}, \vec{v}} \rightarrow \bar{\mathcal{M}}_{\chi, \vec{d}, \vec{\mu}}^\bullet(\hat{Y}^{\text{rel}})^T$$

whose image $\mathcal{F}_{\vec{\chi}, \vec{v}}$ is a union of connected components of $\bar{\mathcal{M}}_{\chi, \vec{d}, \vec{\mu}}^\bullet(\hat{Y}^{\text{rel}})^T$. The morphism $i_{\vec{\chi}, \vec{v}}$ induces an isomorphism

$$\bar{\mathcal{M}}_{\vec{\chi}, \vec{v}} / \left(\prod_{\vec{e} \in E(\Gamma)} A_{\vec{\chi}, \vec{v}}^{\vec{e}} \right) \cong \mathcal{F}_{\vec{\chi}, \vec{v}},$$

where $A_{\vec{\chi}, \vec{v}}^{\vec{e}}$ is the automorphism group associated to the edge \vec{e} :

$$A_{\vec{\chi}, \vec{v}}^{\vec{e}} = \prod_{j=1}^{\ell(v^e)} \mathbb{Z}_{v_j^e}, \quad \{\mathfrak{v}_0(e), \mathfrak{v}_1(e)\} \cap V_1(\Gamma) = \{v\} \neq \emptyset \quad \text{and} \quad r^v = 0;$$

$$1 \rightarrow \prod_{j=1}^{\ell(v^e)} \mathbb{Z}_{v_j^e} \rightarrow A_{\vec{\chi}, \vec{v}}^{\vec{e}} \rightarrow \text{Aut}(v^e) \rightarrow 1, \quad \text{otherwise.}$$

The fixed points set $\overline{\mathcal{M}}_{\chi, \vec{d}, \vec{\mu}}^{\bullet}(\widehat{Y}^{\text{rel}}, \widehat{L})^T$ is a disjoint union of

$$\{\mathcal{F}_{\vec{\chi}, \vec{v}} \mid (\vec{\chi}, \vec{v}) \in G_{\chi, \vec{d}, \vec{\mu}}^{\bullet}(\Gamma)\}.$$

7.2 Perfect obstruction theory on fixed points set

There are two perfect obstruction theories on $\mathcal{F}_{\vec{\chi}, \vec{v}}$: one is the fixing part $[T^{1,f} \rightarrow T^{2,f}]$ of the restriction of the perfect obstruction theory on $\overline{\mathcal{M}}_{\chi, \vec{d}, \vec{\mu}}^{\bullet}(\widehat{Y}^{\text{rel}}, \widehat{L})$; the other comes from the perfect obstruction theory on the moduli spaces

$$\overline{\mathcal{M}}_{\chi^v, \ell_{\vec{v}}(v)}^{\bullet} \quad \text{and} \quad \overline{\mathcal{M}}_{\chi, v, \mu}^{\bullet \sim}$$

Let $[\overline{\mathcal{M}}_{\vec{\chi}, \vec{v}}]^{\text{vir}}$ denote the virtual cycle defined by $[T^{1,f} \rightarrow T^{2,f}]$. By inspecting the T -action on the perfect obstruction theory on $\overline{\mathcal{M}}_{\chi, \vec{d}, \vec{\mu}}^{\bullet}(\widehat{Y}^{\text{rel}}, \widehat{L})$ (see Li [20] and the description in Section 4), we get

$$[\overline{\mathcal{M}}_{\vec{\chi}, \vec{v}}]^{\text{vir}} = \prod_{v \in V(\Gamma)} [\overline{\mathcal{M}}_{\vec{\chi}, \vec{v}}^v]^{\text{vir}}$$

where

$$[\overline{\mathcal{M}}_{\vec{\chi}, \vec{v}}^v]^{\text{vir}} = \begin{cases} \{\{\text{pt}\}\}, & v \in V_1(\Gamma) \cup V_2(\Gamma), r^v = 0, \\ [\overline{\mathcal{M}}_{\chi^v, v^e, \mu^v}^{\bullet \sim}]^{\text{vir}}, & v \in V_1(\Gamma), v_1^{-1}(v) = \{e\}, r^v > 0, \\ c_1(\mathbb{L}) \cap [\overline{\mathcal{M}}_{\chi^v, v^e, v^{e'}}^{\bullet \sim}]^{\text{vir}}, & v \in V_2(\Gamma), v_1^{-1}(v) = \{e, e'\}, r^v > 0, \\ [\overline{\mathcal{M}}_{\chi^v, \ell_{\vec{v}}(v)}^{\bullet}], & v \in V_3(\Gamma). \end{cases}$$

Here \mathbb{L} is a line bundle on $\overline{\mathcal{M}}_{\vec{\chi}, \vec{v}}^v$ coming from the restriction of the line bundle \mathbf{L}^v on $\overline{\mathcal{M}}_{\chi, \vec{d}, \vec{\mu}}^{\bullet}(\widehat{Y})$ (see Section 4.3).

We now give a more explicit description of \mathbb{L} . Let

$$u: (X, \mathbf{q}) \longrightarrow (\mathbb{P}^1(m), p_0, p_m)$$

represent a point in $\overline{\mathcal{M}}_{\chi^v, v^+, v^-}^{\bullet \sim}$, where $\mathbb{P}^1(m)$ is a chain of $m > 0$ copies of \mathbb{P}^1 with two relative divisors p_0 and p_m . Let Δ_l be the l -th irreducible component of $\mathbb{P}^1(m)$ so that $\Delta_l \cap \Delta_{l+1} = \{p_l\}$. The complex lines

$$\mathbb{L}_u^0 = T_{p_0} \Delta_1, \quad \mathbb{L}_u^1 = \bigotimes_{l=1}^{m-1} T_{p_l} \Delta_l \otimes T_{p_l} \Delta_{l+1} \quad \text{and} \quad \mathbb{L}_u^\infty = T_{p_m} \Delta_m$$

form line bundles $\mathbb{L}^0, \mathbb{L}^1$ and \mathbb{L}^∞ on $\overline{\mathcal{M}}_{\chi^v, v^+, v^-}^{\bullet \sim}$ when we vary u in $\overline{\mathcal{M}}_{\chi^v, v^+, v^-}^{\bullet \sim}$. The line bundle \mathbb{L} is given by

$$\mathbb{L} = \mathbb{L}^0 \otimes \mathbb{L}^1 \otimes \mathbb{L}^\infty.$$

Note that

$$c_1(\mathbb{L}^0) = -\psi^0, \quad c_1(\mathbb{L}^\infty) = -\psi^\infty,$$

where ψ^0, ψ^∞ are target ψ classes (see eg [23, Section 5]).

The line bundle \mathbb{L}^1 has another interpretation. Let \mathcal{D} be the divisor in $\overline{\mathcal{M}}_{\chi^v, v^+, v^-}^{\bullet, \sim}$ that corresponds to morphisms with target $\mathbb{P}^1(m)$, $m > 1$, then $\mathbb{L}^1 = \mathcal{O}(\mathcal{D})$.

Let

$$(7-3) \quad J'_{\chi^v, v^+, v^-} = \{(\chi^+, \chi^-, \sigma) \mid \chi^+, \chi^- \in 2\mathbb{Z}, \sigma \in \mathcal{P}, |\sigma| = |v^+| = |v^-|, \\ -\chi^+ + 2\ell(\sigma) - \chi^- = -\chi^v, \quad -\chi^\pm + \ell(v^\pm) + \ell(\sigma) > 0\}.$$

For each $(\chi^+, \chi^-, \sigma) \in J'_{\chi^v, v^+, v^-}$, there is a morphism

$$\pi_{\chi^+, \chi^-, \sigma} : \overline{\mathcal{M}}_{\chi^+, v^+, \sigma}^{\bullet, \sim} \times \overline{\mathcal{M}}_{\chi^-, \sigma, v^-}^{\bullet, \sim} \longrightarrow \overline{\mathcal{M}}_{\chi^v, v^+, v^-}^{\bullet, \sim}$$

with image is contained in \mathcal{D} . Moreover,

$$[\overline{\mathcal{M}}_{\chi^v, v^+, v^-}^{\bullet, \sim}]^{\text{vir}} \cap c_1(\mathbb{L}^1) \\ = \sum_{\substack{(\chi^+, \chi^-, \sigma) \\ \in J'_{\chi^v, v^+, v^-}}} \frac{a_\sigma}{|\text{Aut}(\sigma)|} (\pi_{\chi^+, \chi^-, \sigma})_* \left([\overline{\mathcal{M}}_{\chi^+, v^+, \sigma}^{\bullet, \sim}]^{\text{vir}} \times [\overline{\mathcal{M}}_{\chi^-, \sigma, v^-}^{\bullet, \sim}]^{\text{vir}} \right)$$

where a_σ and $\text{Aut}(\sigma)$ are defined in Section 2.1.

7.3 Contribution from each label

We follow the definitions in Sections 2.1 and 3.3.

In this subsection, we view the position $\mathfrak{p}(e)$ and the framing $\mathfrak{f}(e)$ as elements in

$$\mathbb{Z}u_1 \oplus \mathbb{Z}u_2 = \Lambda_T \cong H_T^2(\text{pt}, \mathbb{Q}).$$

Recall that $H_T^*(\text{pt}; \mathbb{Q}) = \mathbb{Q}[u_1, u_2]$. The results of localization calculations will involve rational functions of $\mathfrak{p}(e)$ and $\mathfrak{f}(e)$.

Let $N_{\vec{\chi}, \vec{v}}^{\text{vir}}$ denote the pull back of $\mathcal{T}^{1,m} - \mathcal{T}^{2,m}$ of $\mathcal{F}_{\vec{\chi}, \vec{v}}$ under $i_{\vec{\chi}, \vec{v}}$. Let r^v be defined as (7-1) and (7-2). For $e \in E^0(\Gamma)$, let $\vec{e} = \{e, -e\} \in E(\Gamma)$ as before.

With the conventions and the explicit description of $[T^1 \rightarrow T^2]$ in Section 4.3, calculations similar to those in [22, Appendix A] show that

$$\frac{1}{e_T(N_{\vec{\chi}, \vec{v}}^{\text{vir}})} = \prod_{v \in V(\Gamma)} B_v \prod_{\vec{e} \in E(\Gamma)} B_{\vec{e}},$$

where

$$B_v = \begin{cases} 1 & v \in V_1(\Gamma) \cup V_2(\Gamma), r^v = 0, \\ (-1)^{\ell(v^e) - \chi^v/2} a_{ve} \frac{f(e)r^v}{-\mathfrak{p}(e) - \psi^0} & v \in V_1(\Gamma), \mathfrak{v}_1^{-1}(v) = \{e\}, r^v > 0, \\ (-1)^{\ell(v^e) - \chi^v/2} \frac{a_{ve} a_{ve'} f(e)r^v}{(-\mathfrak{p}(e) - \psi^0)(-\mathfrak{p}(e') - \psi^\infty)} & v \in V_2(\Gamma), \mathfrak{v}_1^{-1}(v) = \{e, e'\}, r^v > 0, \\ \prod_{e \in \mathfrak{v}_0^{-1}(v)} \frac{a_{ve} \Lambda^\vee(\mathfrak{p}(e)) \mathfrak{p}(e)^{\ell_{\bar{v}}(v) - 1}}{\prod_{j=1}^{\ell(v^e)} ((\mathfrak{p}(e) \mathfrak{p}(e) - v_j^e \psi_j^e))} & v \in V_3(\Gamma); \end{cases}$$

$$B_{\bar{e}} = (-1)^{n^e d^{\bar{e}}} \cdot \begin{cases} E_{v^e}(\mathfrak{p}(e), \mathfrak{l}_0(e)) & \mathfrak{v}_0(e), \mathfrak{v}_1(e) \in V_3(\Gamma), \\ \cdot E_{v^e}(\mathfrak{p}(-e), \mathfrak{l}_0(-e)) & \\ (-1)^{\ell(v^e) - d^{\bar{e}}} E_{v^e}(\mathfrak{p}(e), \mathfrak{l}_0(e)) & \mathfrak{v}_0(e) \in V_3(\Gamma), \mathfrak{v}_1(e) \notin V_3(\Gamma), \\ 1 & \mathfrak{v}_0(e) \notin V_3(\Gamma), \mathfrak{v}_1(e) \notin V_3(\Gamma). \end{cases}$$

Recall that n^e is defined in Definition 3.4 and $E_v(x, y)$ is defined by (6-4).

For $v \in V_2(\Gamma)$, we have

$$\begin{aligned} & \int_{[\overline{\mathcal{M}}_{\bar{\chi}, \bar{v}}^v]^{\text{vir}}} \frac{f(e)r^v}{(-\mathfrak{p}(e) - \psi^0)(-\mathfrak{p}(e') - \psi^\infty)} \\ &= \int_{[\overline{\mathcal{M}}_{\chi^v, v^e, v^{e'}}^{\bullet}]^{\text{vir}}} \frac{f(e)r^v c_1(\mathbb{L})}{(-\mathfrak{p}(e) - \psi^0)(\mathfrak{p}(e) - \psi^\infty)} \\ &= \int_{[\overline{\mathcal{M}}_{\chi^v, v^e, v^{e'}}^{\bullet}]^{\text{vir}}} \frac{f(e)r^v (-\mathfrak{p}(e) - \psi^0 + \mathfrak{p}(e) - \psi^\infty + c_1(\mathbb{L}^1))}{(-\mathfrak{p}(e) - \psi^0)(\mathfrak{p}(e) - \psi^\infty)} \\ &= \int_{[\overline{\mathcal{M}}_{\chi^v, v^e, v^{e'}}^{\bullet}]^{\text{vir}}} \frac{f(e)r^v}{\mathfrak{p}(e) - \psi^\infty} + \int_{[\overline{\mathcal{M}}_{\chi^v, v^e, v^{e'}}^{\bullet}]^{\text{vir}}} \frac{f(e)r^v}{-\mathfrak{p}(e) - \psi^0} \\ &+ \sum_{\substack{(\chi^+, \chi^-, \sigma) \\ \in \mathcal{J}_{\chi^v, v^e, v^{e'}}}} \frac{a_\sigma}{|\text{Aut}(\sigma)|} \int_{[\overline{\mathcal{M}}_{\chi^+, v^e, \sigma}^{\bullet}]^{\text{vir}}} \frac{f(e)r_{\chi^+, \sigma}^+}{-\mathfrak{p}(e) - \psi^0} \int_{[\overline{\mathcal{M}}_{\chi^-, \sigma, v^{e'}}^{\bullet}]^{\text{vir}}} \frac{f(e)r_{\chi^-, \sigma}^-}{\mathfrak{p}(e) - \psi^\infty} \\ &= |\text{Aut}(v^e) \times \text{Aut}(v^{e'})| \left(\frac{f(e)}{\mathfrak{p}(e)} \right)^{r^v} \sum_{\substack{(\chi^+, \chi^-, \sigma) \\ \in \mathcal{J}_{\chi^v, v^e, v^{e'}}}} (-1)^{r_{\chi^+, \sigma}^+} \frac{H_{\chi^+, v^e, \sigma}^\bullet}{r_{\chi^+, \sigma}^+!} z_\sigma \frac{H_{\chi^-, \sigma, v^{e'}}^\bullet}{r_{\chi^-, \sigma}^-!} \end{aligned}$$

where $r_{\chi^+, \sigma}^+ = -\chi^+ + \ell(v^e) + \ell(\sigma)$, $r_{\chi^-, \sigma}^- = -\chi^- + \ell(\sigma) + \ell(v^{e'})$, and

$$(7-4) \quad J_{\chi^v, v^e, v^{e'}} = J'_{\chi^v, v^e, v^{e'}} \cup \{(2\ell(v^e), \chi, v^e), (\chi, 2\ell(v^{e'}), v^{e'})\}.$$

Given $v \in V_3(\Gamma)$, we can arrange $v_0^{-1}(v) = \{e_1, e_2, e_3\}$ so that $p(e_1) \wedge p(e_2) = u_1 \wedge u_2$. Therefore the ordering (e_1, e_2, e_3) is unique up to cyclic permutation. Let

$$(7-5) \quad \vec{v}^v = (v^{e_1}, v^{e_2}, v^{e_3}), \quad \mathbf{w}^v = (p(e_1), p(e_2), p(e_3)).$$

Then $V_{\chi^v, \vec{v}^v}(\mathbf{w}^v)$ is independent of choice of cyclic ordering of e_1, e_2, e_3 , where $V_{\chi, \vec{v}}(\mathbf{w})$ is defined by (6-3). Set

$$I_{\vec{\chi}, \vec{v}}(u_1, u_2) = \int_{[\mathcal{F}_{\vec{\chi}, \vec{v}}]^{vir}} \frac{1}{e_T(N_{\vec{\chi}, \vec{v}}^{vir})}.$$

Then the following holds:

$$\begin{aligned} & I_{\vec{\chi}, \vec{v}}(u_1, u_2) \\ &= \frac{1}{\prod_{\vec{e} \in E(\Gamma)} |A_{\vec{\chi}, \vec{v}}^{\vec{e}}|} \int_{[\mathcal{M}_{\vec{\chi}, \vec{v}}]^{vir}} \frac{1}{e_T(N_{\vec{\chi}, \vec{v}}^{vir})} \\ &= |\text{Aut}(\vec{\mu})| \prod_{\vec{e} \in E(\Gamma)} (-1)^{n^e d^{\vec{e}}} z_{v^e} \prod_{v \in V_3(\Gamma)} V_{\chi^v, \vec{v}^v}(\mathbf{w}^v) \prod_{e \in v_0^{-1}(V_3(\Gamma))} E_{v^e}(p(e), l_1(e)) \\ &\cdot \prod_{v \in V_1(\Gamma), v_1(e)=v} \sqrt{-1}^{\ell(v^e)+\ell(\mu^v)} (-1)^{d^{\vec{e}}} \cdot \left(\sqrt{-1} \frac{f(e)}{p(e)}\right)^{r^v} \frac{H_{\chi^v, v^e, \mu^v}^\bullet}{r^v!} \\ &\cdot \prod_{\substack{v \in V_2(\Gamma) \\ v_1^{-1}(v)=\{e, e'\}}} \left(\sqrt{-1}^{\ell(v^e)+\ell(v^{e'})} \left(\sqrt{-1} \frac{f(e)}{p(e)}\right)^{r^v} \right. \\ &\quad \cdot \sum_{\substack{(\chi^+, \chi^-, \sigma) \\ \in J_{\chi^v, v^e, v^{e'}}}} \frac{H_{\chi^+, v^e, \sigma}^\bullet}{r_{\chi^+, \sigma}^+!} (-1)^{\ell(\sigma)} z_\sigma \frac{H_{\chi^-, v^{e'}, \sigma}^\bullet}{r_{\chi^-, \sigma}^-!} \end{aligned}$$

So we have:

$$(7-6) \quad \begin{aligned} I_{\vec{\chi}, \vec{v}}(u_1, u_2) &= |\text{Aut}(\vec{\mu})| \prod_{\vec{e} \in E(\Gamma)} (-1)^{n^e d^{\vec{e}}} \prod_{v \in V_3(\Gamma)} \sqrt{-1}^{\ell_{\vec{v}}(v)} G_{\chi^v, \vec{v}^v}^\bullet(\mathbf{w}^v) \\ &\cdot \prod_{\substack{v \in V_1(\Gamma), \\ v_1(e)=v}} \sqrt{-1}^{\ell(\mu^v)+\ell(v^v)} (-1)^{d^{\vec{e}}} \left(\sqrt{-1} \frac{f(e)}{p(e)}\right)^{r^v} \frac{H_{\chi^v, v^v, \mu^i}^\bullet}{r^v!} \end{aligned}$$

$$\cdot \prod_{\substack{v \in V_2(\Gamma) \\ v_1^{-1}(v) = \{e, e'\}}} \left(\sqrt{-1}^{-\ell(v^e) + \ell(v^{e'})} \left(\sqrt{-1} \frac{f(e)}{p(e)} \right)^{r^v} \right) \cdot \sum_{\substack{(\chi^+, \chi^-, \sigma) \\ \in J_{\chi^+, v^e, v^{e'}}}} \frac{H_{\chi^+, v^e, \sigma}^\bullet}{r_{\chi^+, \sigma}^+} z_\sigma (-1)^{\ell(\sigma)} \frac{H_{\chi^-, v^{e'}, \sigma}^\bullet}{r_{\chi^-, \sigma}^-}$$

7.4 Sum over labels

Finally, with the notation above, the formal relative GW invariants of a general FTCY graph Γ are

$$F_{\chi, \vec{d}, \vec{\mu}}^{\bullet \Gamma}(u_1, u_2) = \frac{1}{|\text{Aut}(\vec{\mu})|} \sum_{(\vec{\chi}, \vec{v}) \in G_\chi^\bullet(\Gamma, \vec{d}, \vec{\mu})} I_{\vec{\chi}, \vec{v}}(u_1, u_2).$$

Define a generating function

$$(7-7) \quad F_{\vec{d}, \vec{\mu}}^{\bullet \Gamma}(\lambda; u_1, u_2) = \sum_{\chi \in 2\mathbb{Z}, \chi \leq \ell(\vec{\mu})} \lambda^{-\chi + \ell(\vec{\mu})} F_{\chi, \vec{d}, \vec{\mu}}^{\bullet \Gamma}(u_1, u_2).$$

Then (7-6) becomes

$$(7-8) \quad \begin{aligned} & F_{\vec{d}, \vec{\mu}}^{\bullet \Gamma}(\lambda; u_1, u_2) = \\ & \sum_{|\vec{v}^{\bar{e}}| = \vec{d}(\bar{e})} \prod_{\bar{e} \in E(\Gamma)} (-1)^{n^{\bar{e}} d^{\bar{e}}} z_{\vec{v}^{\bar{e}}} \prod_{v \in V_3(\Gamma)} \sqrt{-1}^{-\ell(\vec{v}^v)} G_{\vec{v}^v}^\bullet(\lambda; \mathbf{w}_v) \\ & \cdot \prod_{\substack{v \in V_1(\Gamma), \\ v_1(e) = v}} (-1)^{d^{\bar{e}}} \sqrt{-1}^{-\ell(v^e) + \ell(\mu^v)} \Phi_{v^e, \mu^v}^\bullet \left(\sqrt{-1} \frac{f(e)}{p(e)} \lambda \right) \\ & \cdot \prod_{\substack{v \in V_2(\Gamma), \\ v_1^{-1}(v) = \{e, e'\}}} \sqrt{-1}^{-\ell(v^e) + \ell(v^{e'})} \Phi_{v^e, \sigma}^\bullet \left(\sqrt{-1} \frac{f(e)}{p(e)} \lambda \right) (-1)^{\ell(\sigma)} z_\sigma \Phi_{v^{e'}, \sigma}^\bullet \left(\sqrt{-1} \frac{f(e')}{p(e')} \lambda \right) \end{aligned}$$

where $G_{\vec{\mu}}^\bullet$ is defined by (2-13), \mathbf{w}_v is defined in (7-5), and $\Phi_{v, \mu}^\bullet$ is defined in Section 2.2. Equations (6-9) and (6-6) imply:

$$(7-9) \quad \begin{aligned} & \sqrt{-1}^{-\ell(\vec{\mu})} G_{\vec{\mu}}^\bullet(\lambda; p(e_1), p(e_2), p(e_3)) \\ & = \sqrt{-1}^{-\ell(\vec{\mu})} \sum_{|v^i| = |\mu^i|} \tilde{F}_{\vec{v}}^\bullet(\lambda; 0) \prod_{i=1}^3 z_{v^i} \Phi_{v^i, \mu^i}^\bullet \left(\sqrt{-1} \frac{l_0(e_i)}{p(e_i)} \lambda \right) \end{aligned}$$

$$= (-1)^{\sum_{i=1}^3 \vec{d}(\bar{e}_i)} \sum_{|v^i|=|\mu^i|} F_{\vec{v}}^{\bullet}(\lambda; 0) \prod_{i=1}^3 \sqrt{-1}^{\ell(v^i)-\ell(\mu^i)} z_{v^i} \Phi_{v^i, \mu^i}^{\bullet} \left(-\sqrt{-1} \frac{l_0(e_i)}{p(e_i)} \lambda \right)$$

7.5 Invariance

In this subsection, we prove that formal relative Gromov–Witten invariants are rational numbers independent of u_1, u_2 (Theorem 4.8). We will use operations on FTCY graphs such as smoothing and normalization (defined in Section 3.4) to reduce this to the invariance of the topological vertex (Theorem 5.2).

Let Γ be a FTCY graph, and let

$$\Gamma_2 = \Gamma_{V_2(\Gamma)}, \quad \Gamma^2 = \Gamma^{V_2(\Gamma)}.$$

Then Γ_2, Γ^2 are *regular* FTCY graphs. We call Γ_2 the *full smoothing* of Γ , and Γ^2 the full resolution of Γ . We have surjective maps

$$\pi_2 = \pi_{V_2(\Gamma)}: E^0(\Gamma) \rightarrow E^0(\Gamma_2), \quad \pi^2 = \pi^{V_2(\Gamma)}: V(\Gamma^2) \rightarrow V(\Gamma).$$

Definition 7.2 Let Γ be a FTCY graph, and let Γ^2 be the full resolution of Γ . Let $(\vec{d}, \vec{\mu})$ be an effective class of Γ . A *splitting type* of $(\vec{d}, \vec{\mu})$ is a map $\vec{\sigma}: V_2(\Gamma) \rightarrow \mathcal{P}$ such that $|\vec{\sigma}(v)| = \vec{d}(\bar{e})$ if $v_1(e) = v$.

Given a splitting type $\vec{\sigma}$ of an effective class $(\vec{d}, \vec{\mu})$ of Γ , let $(\vec{d}, \vec{\mu} \sqcup \vec{\sigma})$ denote the effective class of Γ^2 defined by $\vec{d}: E(\Gamma^2) = E(\Gamma) \rightarrow \mathbb{Z}_{\geq 0}$ and

$$\vec{\mu} \sqcup \vec{\sigma}(v) = \begin{cases} \vec{\mu}(\pi^2(v)), & \pi^2(v) \in V_1(\Gamma) \\ \vec{\sigma}(\pi^2(v)), & \pi^2(v) \in V_2(\Gamma). \end{cases}$$

Let $S_{\vec{d}, \vec{\mu}}$ denote the set of all splitting types of $(\vec{d}, \vec{\mu})$.

The following is clear from the expression (7-8).

Lemma 7.3 Let Γ be a FTCY graph, and let $(\vec{d}, \vec{\mu})$ be an effective class of Γ . Then

$$F_{\vec{d}, \vec{\mu}}^{\bullet \Gamma}(\lambda; u_1, u_2) = \sum_{\sigma \in S_{\vec{d}, \vec{\mu}}} z_{\vec{\sigma}} F_{\vec{d}, \vec{\mu} \sqcup \vec{\sigma}}^{\bullet \Gamma^2}(\lambda; u_1, u_2)$$

where $z_{\vec{\sigma}} = \prod_{v \in V_2(\Gamma)} z_{\vec{\sigma}(v)}$.

By Lemma 7.3, it suffices to consider regular FTCY graphs. For a regular FTCY graph Γ , (7-8) reduces to

$$(7-10) \quad F_{\vec{d}, \vec{\mu}}^{\bullet\Gamma}(\lambda; u_1, u_2) = \sum_{|\nu^{\bar{e}}|=d^{\bar{e}} \bar{e} \in E(\Gamma)} \prod_{v \in V_3(\Gamma)} (-1)^{n^e d^{\bar{e}}} z_{\nu^{\bar{e}}} \prod_{v \in V_3(\Gamma)} \sqrt{-1}^{\ell(\vec{\nu}^v)} G_{\vec{\nu}^v}^{\bullet}(\lambda; \mathbf{w}_v) \cdot \prod_{v \in V_1(\Gamma), \mathfrak{v}_1(e)=v} (-1)^{d^{\bar{e}}} \sqrt{-1}^{\ell(v^e)+\ell(\mu^v)} \Phi_{\nu^e, \mu^v}^{\bullet} \left(\sqrt{-1} \frac{\mathfrak{f}(e)}{\mathfrak{p}(e)} \lambda \right)$$

since $V_2(\Gamma) = \emptyset$.

Let $(\vec{d}, \vec{\mu})$ be the effective class of a regular FTCY graph. Let $P_{\vec{d}, \vec{\mu}}$ be the set of all maps $\vec{v}: E^\circ(\Gamma) \rightarrow \mathcal{P}$ such that

- $|\vec{v}(e)| = d^{\bar{e}}$;
- $\vec{v}(e) = \vec{\mu}(v)$ if $\mathfrak{v}_0(e) = v \in V_1(\Gamma)$.

Note that we do not require $\vec{v}(e) = \vec{v}(-e)$. Denote $\vec{v}(e)$ by ν^e . Given $v \in V_3(\Gamma)$, there exist $e_1, e_2, e_3 \in E(\Gamma)$, unique up to a cyclic permutation, such that $\mathfrak{v}_0^{-1}(v) = \{e_1, e_2, e_3\}$ and $\mathfrak{p}(e_1) \wedge \mathfrak{p}(e_2) = u_1 \wedge u_2$. Define

$$(7-11) \quad \vec{\nu}^v = (\nu^{e_1}, \nu^{e_2}, \nu^{e_3}) \quad \text{and} \quad z_{\vec{\nu}^v} = z_{\nu^{e_1}} z_{\nu^{e_2}} z_{\nu^{e_3}}.$$

Note that $F_{\vec{\nu}^v}^{\bullet}(\lambda; \mathbf{0})$ and $z_{\vec{\nu}^v}$ are invariant under cyclic permutations of e_1, e_2, e_3 , thus well-defined.

Using (7-9) and the sum formula (2-9) of double Hurwitz numbers, we can rewrite (7-10) as follows:

$$(7-12) \quad F_{\vec{d}, \vec{\mu}}^{\bullet\Gamma}(\lambda; u_1, u_2) = \sum_{\vec{v} \in P_{\vec{d}, \vec{\mu}}} \prod_{v \in V_3(\Gamma)} F_{\vec{\nu}^v}^{\bullet}(\lambda; \mathbf{0}) z_{\vec{\nu}^v} \prod_{\bar{e} \in E(\Gamma)} \sqrt{-1}^{\ell(v^e) - \ell(v^{-e})} (-1)^{n^e d^{\bar{e}}} \Phi_{\nu^e, \nu^{-e}}^{\bullet}(\sqrt{-1} n^e \lambda).$$

Note that the right hand side of (7-12) does not depend on u_1, u_2 . This completes the proof of Theorem 4.8. From now on, we write $F_{\vec{d}, \vec{\mu}}^{\bullet\Gamma}(\lambda)$ instead of $F_{\vec{d}, \vec{\mu}}^{\bullet\Gamma}(\lambda; u_1, u_2)$. We define

$$F_{\chi, \vec{d}, \vec{\mu}}^{\bullet\Gamma} = F_{\chi, \vec{d}, \vec{\mu}}^{\bullet\Gamma}(u_1, u_2),$$

to be formal relative Gromov–Witten invariants of $\hat{Y}_\Gamma^{\text{rel}}$.

7.6 Gluing formulae

Let $(\vec{d}, \vec{\mu})$ be an effective class of a regular FTCY graph Γ . Let

$$T_{\vec{d}, \vec{\mu}} = \left\{ \vec{v}: E(\Gamma) \rightarrow \mathcal{P} \mid |\vec{v}(e)| = \vec{d}(\bar{e}), \vec{v}(-e) = \vec{v}(e)^t \right\}.$$

Note that we do not require $\vec{v}(e) = \vec{\mu}(v)$ if $\mathfrak{v}_0(e) = v \in V_1(E)$. We have

$$(7-13) \quad F_{\vec{\mu}}^\bullet(\lambda; \mathbf{0}) = \frac{(-1)^{|\mu^1|+|\mu^2|+|\mu^3|}}{\sqrt{-1}^{\ell(\vec{\mu})}} \sum_{|v^i|=|\mu^i|} \tilde{C}_{\vec{v}}(\lambda) \prod_{i=1}^3 \frac{\chi_{v^i}(\mu^i)}{z_{\mu^i}},$$

where $\tilde{C}_{\vec{v}}(\lambda) = \tilde{C}_{\vec{v}}(\lambda; \mathbf{0})$. Applying (7-13) and the Burnside formula (2-8) of double Hurwitz numbers, we see that (7-12) is equivalent to the following.

Proposition 7.4 *Let Γ be a regular FTCY graph. Then*

$$F_{\vec{d}, \vec{\mu}}^{\bullet\Gamma}(\lambda) = \sum_{\vec{v} \in T_{\vec{d}, \vec{\mu}}} \prod_{\bar{e} \in E(\Gamma)} (-1)^{(n^e+1)d^{\bar{e}}} e^{-\sqrt{-1}\kappa_{v^e} n^e \lambda/2} \prod_{v \in V_3(\Gamma)} \tilde{C}_{\vec{v}v}(\lambda) \prod_{\substack{v \in V_1(\Gamma) \\ \mathfrak{v}_0(e)=v}} \frac{\chi_{v^e}(\mu^v)}{\sqrt{-1}^{\ell(\mu^v)} z_{\mu^v}}.$$

Recall that κ_{v^e} is defined by (2-3), and we have $n^{-e} = -n^e$, $\kappa_{v^t} = -\kappa_v$, so

$$\kappa_{v^{-e}} n^{-e} = \kappa_{(v^e)^t} \cdot (-n^e) = \kappa_{v^e} n^e.$$

Theorem 7.5 (Gluing formula) *Let Γ be a FTCY graph, and let Γ_2 and Γ^2 be its full smoothing and its full resolution, respectively. Let $(\vec{d}, \vec{\mu})$ be an effective class of Γ which can also be viewed as an effective class of Γ_2 . Then*

$$F_{\vec{d}, \vec{\mu}}^{\bullet\Gamma_2}(\lambda) = F_{\vec{d}, \vec{\mu}}^{\bullet\Gamma}(\lambda) = \sum_{\vec{\sigma} \in S_{\vec{d}, \vec{\mu}}} z_{\vec{\sigma}} F_{\vec{d}_\Gamma, \vec{\mu}_\Gamma, \vec{\sigma}}^{\bullet\Gamma^2}(\lambda).$$

Proof By Lemma 7.3 and Proposition 7.4, it suffices to show that if $|\mu| = |v| = d$, then

$$\sum_{|\sigma|=d} \frac{\chi_\mu(\sigma)}{\sqrt{-1}^{\ell(\sigma)} z_\sigma} z_\sigma \frac{\chi_v(\sigma)}{\sqrt{-1}^{\ell(\sigma)} z_\sigma} = (-1)^d \delta_{\mu(v^t)},$$

which is obvious. □

7.7 Sum over effective classes

Given a regular FTCY graph, let $\text{Eff}(\Gamma)$ denote the set of effective classes of Γ . Introduce formal Kähler parameters

$$\mathbf{t} = \{t^{\bar{e}} : \bar{e} \in E(\Gamma)\}$$

and winding parameters

$$\mathbf{p} = \{p^v = (p_1^v, p_2^v, \dots) : v \in V_1(\Gamma)\}$$

We define the *formal relative Gromov–Witten partition function* of $\hat{Y}_\Gamma^{\text{rel}}$ to be

$$(7-14) \quad Z_{\text{rel}}^\Gamma(\lambda; \mathbf{t}; \mathbf{p}) = \sum_{(\vec{d}, \vec{\mu}) \in \text{Eff}(\Gamma)} F_{\vec{d}, \vec{\mu}}^{\bullet\Gamma}(\lambda) e^{-\sum_{\bar{e} \in E(\Gamma)} \vec{d}(\bar{e}) t^{\bar{e}}} \prod_{v \in V_1(\Gamma)} p_{\mu^v}^v$$

where $p_\mu^v = p_{\mu_1}^v \cdots p_{\mu_{\ell(\mu)}}^v$.

Let T^Γ denote the set of pairs $(\vec{v}, \vec{\mu})$ such that

- $\vec{v}: E^o(\Gamma) \rightarrow \mathcal{P}$ such that $\vec{v}(-e) = \vec{v}(e)^t$;
- $\vec{\mu}: V_1(\Gamma) \rightarrow \mathcal{P}$;
- $|v^e| = |\mu^v|$ if $v_0(e) = v$.

We abbreviate $\vec{v}(e)$ to v^e for $e \in E^o(\Gamma)$, abbreviate $\vec{\mu}(v)$ to μ^v for $v \in V_1(\Gamma)$, and define $\vec{\mu}^v$ by (7-11) for $v \in V_3(\Gamma)$. The following is a direct consequence of Proposition 7.4.

Corollary 7.6

$$Z_{\text{rel}}^\Gamma(\lambda; \mathbf{t}; \mathbf{p}) = \sum_{(\vec{v}, \vec{\mu}) \in T^\Gamma} \prod_{\bar{e} \in E(\Gamma)} e^{-|v^e| t^{\bar{e}}} (-1)^{(n^e+1)|v^e|} e^{-\sqrt{-1} \kappa_v e n^e \lambda / 2} \\ \cdot \prod_{v \in V_3(\Gamma)} \tilde{C}_{\vec{v}^v}(\lambda) \prod_{v \in V_1(\Gamma), v_0(e)=v} \frac{\chi_{v^e}(\mu^v)}{\sqrt{-1}^{\ell(\mu^v)} z_{\mu^v}}$$

8 Combinatorial expressions for the topological vertex

We use the notation introduced in Section 2.1. The goal of this section is to derive the following combinatorial expression for $\tilde{C}_{\vec{\mu}}(\lambda)$:

Theorem 8.1 Let $\bar{\mu} \in \mathcal{P}_+^3$. Then

$$\tilde{C}_{\bar{\mu}}(\lambda) = \tilde{\mathcal{W}}_{\bar{\mu}}(q),$$

where $q = e^{\sqrt{-1}\lambda}$, and $\tilde{\mathcal{W}}_{\bar{\mu}}(q)$ is defined by (2-7).

We now outline our strategy to prove Theorem 8.1. By Proposition 6.6,

$$\tilde{C}_{\bar{\mu}}(\lambda) = \sum_{|v^i|=|\mu^i|} \prod_{i=1}^3 \chi_{\mu^i}(v^i) q^{-\frac{1}{2}(\sum_{i=1}^3 \kappa_{v^i} w_{i+1}/w_i)} G_{\bar{v}}^{\bullet}(\lambda; \mathbf{w}),$$

where \mathbf{w} is as in (2-11). Since the above sum is independent of \mathbf{w} , we may take $\mathbf{w} = (1, 1, -2)$ and obtain

$$\tilde{C}_{\bar{\mu}}(\lambda) = \sum_{|v^i|=|\mu^i|} \prod_{i=1}^3 \chi_{\mu^i}(v^i) q^{-\frac{1}{2}\kappa_{v^1} + \kappa_{v^2} + \frac{1}{4}\kappa_{v^3}} \cdot G_{\bar{v}}^{\bullet}(\lambda; 1, 1, -2).$$

In Section 8.1, we show that the main result in [23] gives a combinatorial expression of $G_{\mu, v, \emptyset}^{\bullet}(\lambda; \mathbf{w})$ (Theorem 8.7). In Section 8.2, we relate $G_{\bar{v}}^{\bullet}(\lambda; 1, 1, -2)$ to $G_{\emptyset, \mu^1 \cup \mu^2, \mu^3}^{\bullet}(\lambda; 1, 1, -2)$. This gives the combinatorial expression $\tilde{\mathcal{W}}_{\bar{\mu}}(q)$ in Theorem 8.1. Moreover, (6-13) and Theorem 8.1 imply the following formula of three-partition Hodge integrals.

Theorem 8.2 (Formula of three-partition Hodge integrals) Let \mathbf{w} be as in (2-11) and let $\bar{\mu} = (\mu^1, \mu^2, \mu^3) \in \mathcal{P}_+^3$. Then

$$G_{\bar{\mu}}^{\bullet}(\lambda; \mathbf{w}) = \sum_{|v^i|=|\mu^i|} \prod_{i=1}^3 \frac{\chi_{v^i}(\mu^i)}{z^{\mu^i}} q^{\frac{1}{2}(\sum_{i=1}^3 \kappa_{v^i} w_{i+1}/w_i)} \tilde{\mathcal{W}}_{\bar{v}}(q).$$

The cyclic symmetry of $\tilde{C}_{\bar{\mu}}(\lambda)$ is obvious from definition. By Theorem 8.1 we have the following cyclic symmetry

$$\tilde{\mathcal{W}}_{\mu^1, \mu^2, \mu^3}(q) = \tilde{\mathcal{W}}_{\mu^2, \mu^3, \mu^1}(q) = \tilde{\mathcal{W}}_{\mu^3, \mu^1, \mu^2}(q)$$

which is far from being obvious.

Finally, we conjecture that the combinatorial expression $\tilde{\mathcal{W}}_{\bar{\mu}}(q)$ coincides with $\mathcal{W}_{\bar{\mu}}(q)$ predicted in [1]:

Conjecture 8.3 Let $\bar{\mu} \in \mathcal{P}_+^3$. Then

$$\tilde{\mathcal{W}}_{\bar{\mu}}(q) = \mathcal{W}_{\bar{\mu}}(q),$$

where $q = e^{\sqrt{-1}\lambda}$, and $\mathcal{W}_{\vec{\mu}}(q)$ is defined by (2-6).

We have strong evidence for Conjecture 8.3. By Theorem 8.1 and Corollary 8.8, Conjecture 8.3 holds when one of the three partitions is empty. When none of the partitions is empty, A Klemm has checked by computer that Conjecture 8.3 holds in all the cases where

$$|\mu^i| \leq 6, \quad i = 1, 2, 3.$$

We will list some of these cases in Section 8.4.

As explained in Section 1, Conjecture 8.3 will follow from the results in [28].

8.1 One-partition and two-partition Hodge integrals

We recall some notation in [22]:

$$\begin{aligned} C_{\mu}^{\bullet}(\lambda; \tau) &= \sqrt{-1}^{|\mu|} G_{\mu, \emptyset, \emptyset}^{\bullet}(\lambda; 1, \tau, -\tau - 1), \\ V_{\mu}(q) &= q^{-\kappa_{\mu}/4} \sqrt{-1}^{|\mu|} \mathcal{W}_{\mu}(q), \end{aligned}$$

where $\mathcal{W}_{\mu}(q) = \mathcal{W}_{\mu, \emptyset, \emptyset}(q)$ is defined in Section 2.1. The main result of [22] is the following formula conjectured by Mariño and Vafa [25] (see Okounkov and Pandharipande [29] for another proof):

Theorem 8.4

$$C_{\mu}^{\bullet}(\lambda; \tau) = \sum_{|v|=|\mu|} \frac{\chi(\mu)}{z_{\mu}} q^{\kappa_v(\tau + \frac{1}{2})/2} V_v(q)$$

Theorem 8.4 can be reformulated in our notation as follows:

Theorem 8.5 (Formula of one-partition Hodge integrals) *Let \mathbf{w} be as in (2-11), and let $\mu \in \mathcal{P}_+$. Then*

$$G_{\mu, \emptyset, \emptyset}^{\bullet}(\lambda; \mathbf{w}) = \sum_{|v|=|\mu|} \frac{\chi_v(\mu)}{z_{\mu}} q^{\frac{1}{2}\kappa_v w_2/w_1} \mathcal{W}_{v, \emptyset, \emptyset}(q).$$

Let

$$G_{\mu^+, \mu^-}^{\bullet}(\lambda; \tau) = (-1)^{|\mu^-| - \ell(\mu^-)} G_{\mu^+, \mu^-, \emptyset}^{\bullet}(\lambda; 1, \tau, -1 - \tau).$$

The main result of [23] is the following formula conjectured in [35]:

Theorem 8.6 Let $(\mu^+, \mu^-) \in \mathcal{P}_+^2$. Then

$$G_{\mu^+, \mu^-}^\bullet(\lambda; \tau) = \sum_{|v^\pm|=|\mu^\pm|} \frac{\chi_{v^+}(\mu^+)}{z_{\mu^+}} \frac{\chi_{v^-}(\mu^-)}{z_{\mu^-}} q^{(\kappa_{v^+} \tau + \kappa_{v^-} \tau^{-1})/2} \mathcal{W}_{v^+, v^-}(q).$$

We now reformulate Theorem 8.6 in the notation of this paper.

$$\begin{aligned} G_{\mu^1, \mu^2, \emptyset}^\bullet(\lambda; 1, \tau, -1 - \tau) &= (-1)^{|\mu^2| - \ell(\mu^2)} \sum_{|v^i|=|\mu^i|} \frac{\chi_{v^1}(\mu^1)}{z_{\mu^1}} \frac{\chi_{v^2}(\mu^2)}{z_{\mu^2}} q^{(\kappa_{v^1} \tau + \kappa_{v^2} \tau^{-1})/2} \mathcal{W}_{v^1, v^2}(q) \\ &= \sum_{|v^i|=|\mu^i|} \frac{\chi_{v^1}(\mu^1)}{z_{\mu^1}} \frac{\chi_{(v^2)^t}(\mu^2)}{z_{\mu^2}} q^{(\kappa_{v^1} \tau + \kappa_{v^2} \tau^{-1})/2} q^{\kappa_{v^2}/2} \mathcal{W}_{v^1, (v^2)^t, \emptyset}(q) \\ &= \sum_{|v^i|=|\mu^i|} \frac{\chi_{v^1}(\mu^1)}{z_{\mu^1}} \frac{\chi_{v^2}(\mu^2)}{z_{\mu^2}} q^{(\kappa_{v^1} \tau + \kappa_{v^2} \frac{-\tau-1}{\tau})/2} \mathcal{W}_{v^1, v^2, \emptyset}(q) \end{aligned}$$

Theorem 8.6 is equivalent to the following:

Theorem 8.7 (Formula of two-partition Hodge integrals) Let \mathbf{w} be as in (2-11) and let $(\mu^1, \mu^2) \in \mathcal{P}_+^2$. Then

$$G_{\mu^1, \mu^2, \emptyset}^\bullet(\lambda; \mathbf{w}) = \sum_{|v^i|=|\mu^i|} \sum_{|v^i|=|\mu^i|} \frac{\chi_{v^1}(\mu^1)}{z_{\mu^1}} \frac{\chi_{v^2}(\mu^2)}{z_{\mu^2}} q^{\frac{1}{2}(\kappa_{v^1} w_2/w_1 + \kappa_{v^2} w_3/w_2)} \mathcal{W}_{v^1, v^2, \emptyset}(q).$$

Note that Theorem 8.5 corresponds to the special case where $(\mu^1, \mu^2) = (\mu, \emptyset)$. Theorem 8.7 and (6-12) imply:

Corollary 8.8 Let $\vec{\mu} = (\mu^1, \mu^2, \mu^3) \in \mathcal{P}_+^3$, and let $q = e^{\sqrt{-1}\lambda}$. Then

$$\tilde{C}_{\vec{\mu}}(\lambda) = \mathcal{W}_{\vec{\mu}}(q)$$

when one of μ^1, μ^2, μ^3 is empty.

8.2 Reduction

Recall that

$$G_{g, \vec{\mu}}(\tau) = G_{g, \vec{\mu}}(1, \tau, -\tau - 1).$$

For two partitions μ^1 and μ^2 , let $\mu^1 \cup \mu^2$ be the partition with

$$m_i(\mu^1 \cup \mu^2) = m_i(\mu^1) + m_i(\mu^2), \quad \forall i \geq 1.$$

We have:

Lemma 8.9 Let $\vec{\mu} = (\mu^1, \mu^2, \mu^3) \in \mathcal{P}_+^3$. Then

$$(8-1) \quad \begin{aligned} G_{g, \vec{\mu}}(\lambda; 1) &= (-1)^{|\mu^1| - \ell(\mu^1)} \frac{z_{\mu^1 \cup \mu^2}}{z_{\mu^1} \cdot z_{\mu^2}} G_{g, \emptyset, \mu^1 \cup \mu^2, \mu^3}(\lambda; 1) \\ &+ \delta_{g0} \sum_{m \geq 1} \delta_{\mu^1(m)} \delta_{\mu^2 \emptyset} \delta_{\mu^3(2m)} \frac{(-1)^{m-1}}{m}. \end{aligned}$$

Proof Let

$$I_{g, \vec{\mu}}(\mathbf{w}) = \int_{\overline{\mathcal{M}}_{g, \ell(\vec{\mu})}} \prod_{i=1}^3 \frac{\Lambda^\vee(w_i) w_i^{\ell(\vec{\mu})-1}}{\prod_{j=1}^{\ell(\mu^i)} (w_i (w_i - \mu_j^i \psi_{d_{\vec{\mu}}^i + j}))}$$

and let $I_{g, \vec{\mu}}(\tau) = I_{g, \vec{\mu}}(1, \tau, -\tau - 1)$. Then

$$I_{0, \vec{\mu}}(\tau) = \frac{(\tau(-\tau - 1))^{\ell(\vec{\mu})-1}}{\tau^{2\ell(\mu^2)} (-\tau - 1)^{2\ell(\mu^3)}} \left(|\mu^1| + \frac{|\mu^2|}{\tau} + \frac{|\mu^3|}{-\tau - 1} \right)^{\ell(\vec{\mu})-3}$$

Note that $I_{g, \vec{\mu}}(\tau)$ has a pole at $\tau = 1$ only if

$$(8-2) \quad g = 0, \quad \vec{\mu} = ((m), \emptyset, (2m)) \text{ or } (\emptyset, (m), (2m)),$$

where $m > 0$. Let

$$E_\mu(\tau) = \prod_{j=1}^{\ell(\mu)} \frac{\prod_{a=1}^{\mu_j-1} (\tau \mu_j + a)}{(\mu_j - 1)!}.$$

Then $E_\mu(\tau)$ is a polynomial in τ of degree $|\mu| - \ell(\mu)$, and

$$E_\mu(-\tau - 1) = (-1)^{|\mu| - \ell(\mu)} E_\mu(\tau).$$

Then

$$\begin{aligned} G_{g, \vec{\mu}}(\tau) &= \frac{(-\sqrt{-1})^{\ell(\vec{\mu})}}{|\text{Aut}(\vec{\mu})|} E_{\mu^1}(\tau) E_{\mu^2}(-1 - \tau^{-1}) E_{\mu^3} \left(\frac{1}{-\tau - 1} \right) I_{g, \vec{\mu}}(\tau) \\ &= (-1)^{|\mu^1| - \ell(\mu^1)} \frac{(-\sqrt{-1})^{\ell(\vec{\mu})}}{|\text{Aut}(\vec{\mu})|} E_{\mu^1}(-1 - \tau) E_{\mu^2}(-1 - \tau^{-1}) E_{\mu^3} \left(\frac{1}{-\tau - 1} \right) I_{g, \vec{\mu}}(\tau) \end{aligned}$$

$$\text{while } G_{g, \emptyset, \mu^1 \cup \mu^2, \mu^3}(\tau) = \frac{(-\sqrt{-1})^{\ell(\vec{\mu})}}{|\text{Aut}(\mu^1 \cup \mu^2) \times \text{Aut}(\mu^3)|} E_{\mu^1 \cup \mu^2}(-1 - \tau^{-1}) \\ \cdot E_{\mu^3} \left(\frac{1}{-\tau - 1} \right) I_{g, \emptyset, \mu^1 \cup \mu^2, \mu^3}(\tau)$$

where $E_{\mu^1 \cup \mu^2}(-1 - \tau^{-1}) = E_{\mu^1}(-1 - \tau^{-1}) E_{\mu^2}(-1 - \tau^{-1})$.

Suppose that $(g, \vec{\mu})$ is not the exceptional case listed in (8-2). Then neither is $(g, \emptyset, \mu^1 \cup \mu^2, \mu^3)$. It is immediate from the definition that

$$I_{g, \mu^1, \mu^2, \mu^3}(1) = I_{g, \emptyset, \mu^1 \cup \mu^2, \mu^3}(1),$$

so

$$(8-3) \quad G_{g, \vec{\mu}}(1) = (-1)^{|\mu^1| - \ell(\mu^1)} \frac{|\text{Aut}(\mu^1 \cup \mu^2)|}{|\text{Aut}(\mu^1) \times \text{Aut}(\mu^2)|} G_{g, \emptyset, \mu^1 \cup \mu^2, \mu^3}(1)$$

For the exceptional case (8-2), we have

$$G_{0, (m), \emptyset, (2m)}(\tau) = \frac{\tau}{(\tau + 1)(m - 1)!(2m - 1)!} \prod_{a=1}^{m-1} (\tau m + a) \\ \cdot \prod_{a=1}^{m-1} \left(\frac{2m}{-\tau - 1} + a \right) \prod_{a=m+1}^{2m-1} \left(\frac{2m}{-\tau - 1} + a \right)$$

$$\text{while } G_{0, \emptyset, (m), (2m)}(\tau) = \frac{-1}{(\tau + 1)(m - 1)!(2m - 1)!} \prod_{a=1}^{m-1} \left(\frac{-\tau - 1}{\tau} m + a \right) \\ \cdot \prod_{a=1}^{m-1} \left(\frac{2m}{-\tau - 1} + a \right) \prod_{a=m+1}^{2m-1} \left(\frac{2m}{-\tau - 1} + a \right).$$

So

$$(8-4) \quad G_{0, (m), \emptyset, (2m)}(1) = \frac{(-1)^{m-1}}{2m}, \quad G_{0, \emptyset, (m), (2m)}(1) = \frac{-1}{2m}.$$

Combining the general case (8-3) and the exceptional case (8-4), we obtain (8-1). \square

Let \mathbf{p} , p^i , p_μ^i be defined as in Section 2.3, and let $G^\bullet(\lambda; \mathbf{p}; \tau)$ be defined as in (2-13). We have:

Lemma 8.10 *Let*

$$(8-5) \quad p_i^+ = (-1)^{i-1} p_i^1 + p_i^2, \quad p_\mu^+ = \prod_{j=1}^{\ell(\mu)} p_{\mu_j}^+.$$

Then

$$(8-6) \quad G^\bullet(\lambda; p^1, p^2, p^3; 1) = G^\bullet(\lambda; 0, p^+, p^3; 1) \exp\left(\sum_{m \geq 1} \frac{(-1)^{m-1}}{m} p_m^1 p_{2m}^3\right).$$

Proof We have

$$G(\lambda; \mathbf{p}; 1) = G(\lambda; \mathbf{p}; 1, 1, -2) = \sum_{\tilde{\mu} \in \mathcal{P}_+^3} \sum_{g=0}^{\infty} \lambda^{2g-2+\ell(\tilde{\mu})} G_{g, \tilde{\mu}}(\lambda; 1) p_{\mu^1}^1 p_{\mu^2}^2 p_{\mu^3}^3.$$

By Lemma 8.9,

$$\begin{aligned} G(\lambda; \mathbf{p}; 1) &= \sum_{\tilde{\mu} \in \mathcal{P}_+^3} \sum_{g=0}^{\infty} \lambda^{2g-2+\ell(\tilde{\mu})} G_{g, \emptyset, \mu^1 \cup \mu^2, \mu^3}(1) \frac{z_{\mu^1 \cup \mu^2}}{z_{\mu^1} z_{\mu^2}} (-1)^{|\mu^1| - \ell(\mu^1)} p_{\mu^1}^1 p_{\mu^2}^2 p_{\mu^3}^3 \\ &\quad + \sum_{m \geq 1} \frac{(-1)^{m-1}}{m} p_m^1 p_{2m}^3 \\ &= \sum_{(\mu^+, \mu^3) \in \mathcal{P}_+^2} \sum_{g=0}^{\infty} \lambda^{2g-2+\ell(\mu^+) + \ell(\mu^3)} G_{g, \emptyset, \mu^+, \mu^3}(1) \\ &\quad \times \left(\sum_{\mu^1 \cup \mu^2 = \mu^+} \frac{z_{\mu^+}}{z_{\mu^1} z_{\mu^2}} (-1)^{|\mu^1| - \ell(\mu^1)} p_{\mu^1}^1 p_{\mu^2}^2 \right) p_{\mu^3}^3 \\ &\quad + \sum_{m \geq 1} \frac{(-1)^{m-1}}{m} p_m^1 p_{2m}^3 \end{aligned}$$

It is easy to see that

$$(8-7) \quad \sum_{\mu^1 \cup \mu^2 = \mu^+} \frac{z_{\mu^+}}{z_{\mu^1} z_{\mu^2}} (-1)^{|\mu^1| - \ell(\mu^1)} p_{\mu^1}^1 p_{\mu^2}^2 = p_{\mu^+}^+.$$

So
$$G(\lambda; p^1, p^2, p^3; 1) = G(\lambda; 0, p^+, p^3; 1) + \sum_{m=1}^{\infty} \frac{(-1)^{m-1}}{m} p_m^1 p_{2m}^3$$

which is equivalent to (8-6). □

8.3 Combinatorial expression

Lemma 8.11 Let p^+ be defined by (8-5).

$$G^\bullet(\lambda; 0, p^+, p^3; 1) = \sum_{v^+, v^i, \mu^i \in \mathcal{P}} c_{(v^1)^t v^2}^{v^+} q^{(-2\kappa_{v^+} - \kappa_{v^3}/2)/2} \mathcal{W}_{v^+, v^3}(q) (-1)^{|\mu^3| - \ell(\mu^3)} \prod_{i=1}^3 \frac{\chi_{v^i}(\mu^i)}{z_{\mu^i}} p_{\mu^i}^i.$$

Proof By Theorem 8.7,

$$G^\bullet(\lambda; 0, p^+, p^3; 1) = \sum_{\mu^\pm, v^\pm, \mu^3 \in \mathcal{P}} \frac{\chi_{v^+}(\mu^+)}{z_{\mu^+}} \frac{\chi_{v^3}(\mu^3)}{z_{\mu^3}} q^{(-2\kappa_{v^+} - \kappa_{v^3}/2)/2} \mathcal{W}_{\emptyset, v^+, v^3}(q) p_{\mu^+}^+ p_{\mu^3}^3.$$

Recall that

$$\begin{aligned} \mathcal{W}_{\emptyset, v^+, v^3}(q) &= q^{\kappa_{v^3}/2} \mathcal{W}_{v^+, (v^3)^t}(q), \\ p_{\mu^+}^+ &= \sum_{\mu^1 \cup \mu^2 = \mu^+} \frac{z_{\mu^+}}{z_{\mu^1} z_{\mu^2}} (-1)^{|\mu^1| - \ell(\mu^1)} p_{\mu^1}^1 p_{\mu^2}^2. \end{aligned}$$

Let $s_\mu^i = \sum_{|v|=|\mu|} \frac{\chi_\mu(v)}{z_v} p_v$ be Schur functions. Then

$$\begin{aligned} G^\bullet(\lambda; 0, p^+, p^3; 1) &= \sum_{\mu^\pm, v^\pm, \mu^3 \in \mathcal{P}} \frac{\chi_{v^+}(\mu^+)}{z_{\mu^+}} \frac{\chi_{v^3}(\mu^3)}{z_{\mu^3}} q^{(-2\kappa_{v^+} + \kappa_{v^3}/2)/2} \mathcal{W}_{v^+, (v^3)^t}(q) p_{\mu^+}^+ p_{\mu^3}^3 \\ &= \sum_{\mu^\pm, v^\pm, \mu^3 \in \mathcal{P}} \frac{\chi_{v^+}(\mu^+)}{z_{\mu^+}} \frac{\chi_{(v^3)^t}(\mu^3)}{z_{\mu^3}} q^{(-2\kappa_{v^+} - \kappa_{v^3}/2)/2} \mathcal{W}_{v^+, v^3}(q) p_{\mu^3}^3 \\ &\quad \cdot \sum_{\mu^1 \cup \mu^2 = \mu^+} \frac{z_{\mu^+}}{z_{\mu^1} \cdot z_{\mu^2}} (-1)^{|\mu^1| - \ell(\mu^1)} p_{\mu^1}^1 p_{\mu^2}^2 \\ &= \sum_{\mu^i, v^+, v^3 \in \mathcal{P}} \left(\frac{\chi_{v^+}(\mu^1 \cup \mu^2)}{z_{\mu^1} \cdot z_{\mu^2}} \frac{\chi_{(v^3)^t}(\mu^3)}{z_{\mu^3}} \right. \\ &\quad \left. \times q^{(-2\kappa_{v^+} - \kappa_{v^3}/2)/2} \mathcal{W}_{v^+, v^3}(q) (-1)^{|\mu^1| - \ell(\mu^1)} p_{\mu^1}^1 p_{\mu^2}^2 p_{\mu^3}^3 \right) \end{aligned}$$

$$\begin{aligned}
 &= \sum_{\mu^1, \mu^2, \nu^+, \nu^i \in \mathcal{P}} \left(\frac{\chi_{\nu^+}(\mu^1 \cup \mu^2) \chi_{\nu^1}(\mu^1) \chi_{\nu^2}(\mu^2)}{z_{\mu^1} \cdot z_{\mu^2}} \right. \\
 &\quad \left. \times q^{(-2\kappa_{\nu^+} - \kappa_{\nu^3}/2)/2} \mathcal{W}_{\nu^+, \nu^3}(q) (-1)^{|\mu^1| - \ell(\mu^1)} s_{\nu^1}^1 s_{\nu^2}^2 s_{(\nu^3)'}^3 \right) \\
 &= \sum_{\mu^1, \mu^2, \nu^+, \nu^i \in \mathcal{P}} \left(\frac{\chi_{\nu^+}(\mu^1 \cup \mu^2) \chi_{(\nu^1)'}(\mu^1) \chi_{\nu^2}(\mu^2)}{z_{\mu^1} \cdot z_{\mu^2}} \right. \\
 &\quad \left. \times q^{(-2\kappa_{\nu^+} - \kappa_{\nu^3}/2)/2} \mathcal{W}_{\nu^+, \nu^3}(q) s_{\nu^1}^1 s_{\nu^2}^2 s_{(\nu^3)'}^3 \right) \\
 &= \sum_{\nu^+, \nu^i \in \mathcal{P}} c_{(\nu^1)'}^{\nu^+} \nu^2 q^{(-2\kappa_{\nu^+} - \kappa_{\nu^3}/2)/2} \mathcal{W}_{\nu^+, \nu^3}(q) s_{\nu^1}^1 s_{\nu^2}^2 s_{(\nu^3)'}^3 \\
 &= \sum_{\nu^+, \nu^i, \mu^i \in \mathcal{P}} c_{(\nu^1)'}^{\nu^+} \nu^2 q^{(-2\kappa_{\nu^+} - \kappa_{\nu^3}/2)/2} \mathcal{W}_{\nu^+, \nu^3}(q) (-1)^{|\mu^3| - \ell(\mu^3)} \prod_{i=1}^3 \frac{\chi_{\nu^i}(\mu^i)}{z_{\mu^i}} p_{\mu^i}^i.
 \end{aligned}$$

In the above we have used (8-7) and the following identity:

$$c_{\mu^+ \mu^-}^{\mu} = \sum_{\nu^+, \nu^-} \frac{\chi_{\mu^+}(\nu^+) \chi_{\mu^-}(\nu^-) \chi_{\mu}(\nu^+ \cup \nu^-)}{z_{\nu^+} z_{\nu^-}}. \quad \square$$

Remark 8.12 By the same method we also have

$$\begin{aligned}
 (8-8) \quad &G^\bullet(\lambda; 0, p^+, p^3; 1) \\
 &= \sum_{\gamma^+, \gamma^i, \mu^i \in \mathcal{P}} c_{(\gamma^1)'}^{\gamma^+} \gamma^2 q^{(-2\kappa_{\gamma^+} + \kappa_{\gamma^3}/2)/2} \mathcal{W}_{\gamma^+, (\gamma^3)'}(q) \prod_{i=1}^3 \frac{\chi_{\gamma^i}(\mu^i)}{z_{\mu^i}} p_{\mu^i}^i.
 \end{aligned}$$

Lemma 8.13 We have

$$\exp\left(-\sum_{m \geq 1} \frac{(-1)^{m-1}}{m} p_m^1 p_{2m}^3\right) = \sum_{\mu \in \mathcal{P}} \frac{(-1)^{|\mu| - \ell(\mu)}}{z_{\mu}} p_{\mu}^1 p_{2\mu}^3$$

where 2μ is the partition $(2\mu_1, 2\mu_2, \dots, 2\mu_{\ell(\mu)})$.

Proof Let $(x_1^i, \dots, x_n^i, \dots)$ be formal variables such that $p_m^i = \sum_n (x_n^i)^m$. By standard series manipulations,

$$\begin{aligned} \exp\left(-\sum_{m \geq 1} \frac{(-1)^{m-1}}{m} p_m^2 p_{2m}^3\right) &= \exp\left(\sum_{m \geq 1} \frac{(-1)^{m-1}}{m} \sum_{n_1, n_3} (x_{n_1}^1)^m (x_{n_3}^3)^{2m}\right) \\ &= \prod_{n_1, n_3} \exp\left(\sum_{m \geq 1} \frac{(-1)^{m-1}}{m} (p_{n_1}^1 (p_{n_3}^3)^2)^m\right) = \prod_{n_1, n_3} (1 + x_{n_1}^1 (x_{n_3}^3)^2). \end{aligned}$$

Now recall (cf [24, page 65, (4.1')]):

$$\prod_{i,j} (1 + x_i y_j) = \sum_{\mu \in \mathcal{P}} \frac{(-1)^{|\mu| - \ell(\mu)}}{z_\mu} p_\mu(x) p_\mu(y).$$

Hence we have

$$\begin{aligned} \exp\left(\sum_{m \geq 1} \frac{(-1)^{m-1}}{m} p_m^1 p_{2m}^3\right) &= \sum_{\mu \in \mathcal{P}} \frac{(-1)^{|\mu| - \ell(\mu)}}{z_\mu} p_\mu(x^1) p_\mu((x^3)^2) \\ &= \sum_{\mu \in \mathcal{P}} \frac{(-1)^{|\mu| - \ell(\mu)}}{z_\mu} p_\mu(x^1) p_{2\mu}(x^3). \quad \square \end{aligned}$$

By Lemma 8.10, Lemma 8.11, and Lemma 8.13, we have

$$\begin{aligned} G^\bullet(\lambda; p^1, p^2, p^3; 1) &= G^\bullet(\lambda; 0, p^+, p^3; 1) \exp\left(\sum_{m \geq 1} \frac{(-1)^{m-1}}{m} p_m^1 p_{2m}^3\right) \\ &= \sum_{v^+, v^i \in \mathcal{P}} c_{(v^1)^t v^2}^{v^+} q^{(-2\kappa_v + -\kappa_{v^3}/2)/2} \mathcal{W}_{v^+, v^3} s_{v^1}^1 s_{v^2}^2 s_{(v^3)^t}^3 \\ &\quad \times \sum_{\mu \in \mathcal{P}} \frac{(-1)^{|\mu| - \ell(\mu)}}{z_\mu} p_\mu(x^1) p_{2\mu}(x^3) \\ &= \sum_{v^+, v^i \in \mathcal{P}} c_{(v^1)^t v^2}^{v^+} q^{(-2\kappa_v + -\kappa_{v^3}/2)/2} \mathcal{W}_{v^+, v^3}(q) s_{v^1}^1 s_{v^2}^2 s_{(v^3)^t}^3 \\ &\quad \cdot \sum_{\mu, \eta^1, \eta^3 \in \mathcal{P}} \frac{(-1)^{|\mu| - \ell(\mu)}}{z_\mu} \chi_{\eta^1}(\mu) \chi_{\eta^3}(2\mu) s_{\eta^1}^1 s_{\eta^3}^3 \end{aligned}$$

$$\begin{aligned}
 &= \sum_{\nu^+, \nu^1, \nu^3, \eta^1, \eta^3, \mu \in \mathcal{P}} \left(c_{(\nu^1)^t \nu^2}^{\nu^+} c_{\eta^1 \nu^1}^{\rho^1} c_{\eta^3 (\nu^3)^t}^{\rho^3} q^{(-2\kappa_{\nu^+} - \kappa_{\nu^3}/2)/2} \right. \\
 &\quad \left. \times \mathcal{W}_{\nu^+, \nu^3}(q) \frac{\chi_{\eta^1}(\mu) \chi_{\eta^3}(2\mu)}{z_{\mu}} s_{\rho^1}^1 s_{\rho^2}^2 s_{\rho^3}^3 \right) \\
 &= \sum_{\nu^+, \nu^1, \nu^3, \eta^1, \eta^3, \mu \in \mathcal{P}} \left(c_{(\nu^1)^t \nu^2}^{\nu^+} c_{(\eta^1)^t \nu^1}^{\rho^1} c_{\eta^3 (\nu^3)^t}^{\rho^3} q^{(-2\kappa_{\nu^+} - \kappa_{\nu^3}/2)/2} \right. \\
 &\quad \left. \times \mathcal{W}_{\nu^+, \nu^3}(q) \frac{\chi_{\eta^1}(\mu) \chi_{\eta^3}(2\mu)}{z_{\mu}} s_{\rho^1}^1 s_{\rho^2}^2 s_{\rho^3}^3 \right).
 \end{aligned}$$

By Proposition 6.6,

$$\begin{aligned}
 G^{\bullet}(\lambda; \mathbf{p}; 1) &= \sum_{\mu^i, \nu^i \in \mathcal{P}} \tilde{C}_{\bar{\nu}}(\lambda) q^{(\kappa_{\nu^1} - 2\kappa_{\nu^2} - \kappa_{\nu^3}/2)/2} \prod_{i=1}^3 \frac{\chi_{\nu^i}(\mu^i)}{z_{\mu^i}} p_{\mu^i}^i \\
 &= \sum_{\nu^i \in \mathcal{P}} \tilde{C}_{\bar{\nu}}(\lambda) q^{(\kappa_{\nu^1} - 2\kappa_{\nu^2} - \kappa_{\nu^3}/2)/2} \prod_{i=1}^3 s_{\nu^i}(x^i).
 \end{aligned}$$

By comparing coefficients,

$$\begin{aligned}
 &\sum c_{(\nu^1)^t \nu^2}^{\nu^+} c_{(\eta^1)^t \nu^1}^{\rho^1} c_{\eta^3 (\nu^3)^t}^{\rho^3} q^{(-2\kappa_{\nu^+} - \kappa_{\nu^3}/2)/2} \mathcal{W}_{\nu^+, \nu^3}(q) \frac{\chi_{\eta^1}(\mu) \chi_{\eta^3}(2\mu)}{z_{\mu}} s_{\rho^1}^1 s_{\rho^2}^2 s_{\rho^3}^3 \\
 &= \sum_{\mu^i, \nu^i \in \mathcal{P}} \tilde{C}_{\bar{\nu}}(\lambda) q^{(\kappa_{\nu^1} - 2\kappa_{\nu^2} - \kappa_{\nu^3}/2)/2} \prod_{i=1}^3 s_{\nu^i}^i.
 \end{aligned}$$

Therefore, $\tilde{C}_{\bar{\rho}}(\lambda) = \tilde{\mathcal{W}}_{\bar{\rho}}(q)$

where $\tilde{\mathcal{W}}_{\bar{\rho}}(q)$ is defined by (2-7). This completes the proof of Theorem 8.1.

Remark 8.14 By (8-8) one gets a slightly different expression.

8.4 Examples of Conjecture 8.3

We have seen in Section 8 that Conjecture 8.3 holds when one of the three partitions is empty. When none of the partitions is empty, A Klemm has checked by computer that Conjecture 8.3 holds in all the cases where

$$|\mu^i| \leq 6, \quad i = 1, 2, 3.$$

We list some of these cases here.

$$\begin{aligned} \tilde{\mathcal{W}}_{(1),(1),(1)}(q) &= \mathcal{W}_{(1),(1),(1)}(q) = \frac{q^4 - q^3 + q^2 - q + 1}{q^{1/2}(q-1)^3} \\ \tilde{\mathcal{W}}_{(1),(1),(2)}(q) &= \mathcal{W}_{(1),(1),(2)}(q) = \frac{q^6 - q^5 + q^3 - q + 1}{(q^2 - 1)(q-1)^3} \\ \tilde{\mathcal{W}}_{(1),(1),(1,1)}(q) &= \mathcal{W}_{(1),(1),(1,1)}(q) = \frac{q^6 - q^5 + q^3 - q + 1}{q(q^2 - 1)(q-1)^3} \\ \tilde{\mathcal{W}}_{(1),(1),(3)}(q) &= \mathcal{W}_{(1),(1),(3)}(q) = \frac{q^{3/2}(q^8 - q^7 + q^4 - q + 1)}{(q^3 - 1)(q^2 - 1)(q-1)^3} \\ \tilde{\mathcal{W}}_{(1),(1),(2,1)}(q) &= \mathcal{W}_{(1),(1),(2,1)}(q) \\ &= \frac{q^8 - 2q^7 + 3q^6 - 3q^5 + 3q^4 - 3q^3 + 3q^2 - 2q + 1}{q^{1/2}(q^3 - 1)(q-1)^4} \\ \tilde{\mathcal{W}}_{(1),(1),(1,1,1)}(q) &= \mathcal{W}_{(1),(1),(1,1,1)}(q) = \frac{q^8 - q^7 + q^4 - q + 1}{q^{3/2}(q^3 - 1)(q^2 - 1)(q-1)^3} \\ \tilde{\mathcal{W}}_{(1),(2),(2)}(q) &= \mathcal{W}_{(1),(2),(2)}(q) = \frac{q^{1/2}(q^8 - q^7 + q^5 - q^4 + q^3 - q + 1)}{(q^2 - 1)^2(q-1)^3} \\ \tilde{\mathcal{W}}_{(1),(1,1),(2)}(q) &= \mathcal{W}_{(1),(1,1),(2)}(q) = \frac{q^9 - q^8 + q^6 - q^5 + 2q^3 - q^2 - q + 1}{q^{3/2}(q^2 - 1)^2(q-1)^3} \\ \tilde{\mathcal{W}}_{(1),(2),(1,1)}(q) &= \mathcal{W}_{(1),(2),(1,1)}(q) = \frac{q^9 - q^8 - q^7 + 2q^6 - q^4 + q^3 - q + 1}{q^{1/2}(q^2 - 1)^2(q-1)^3} \\ \tilde{\mathcal{W}}_{(1),(1,1),(1,1)}(q) &= \mathcal{W}_{(1),(1,1),(1,1)}(q) = \frac{q^8 - q^7 + q^5 - q^4 + q^3 - q + 1}{q^{3/2}(q^2 - 1)^2(q-1)^3} \\ \tilde{\mathcal{W}}_{(1),(1),(4)}(q) &= \mathcal{W}_{(1),(1),(4)}(q) = \frac{q^4(q^{10} - q^9 + q^5 - q + 1)}{(q^4 - 1)(q^3 - 1)(q^2 - 1)(q-1)^3} \\ \tilde{\mathcal{W}}_{(1),(1),(3,1)}(q) &= \mathcal{W}_{(1),(1),(3,1)}(q) \\ &= \frac{q(q^{10} - 2q^9 + 2q^8 - 2q^6 + 3q^5 - 2q^4 + 2q^2 - 2q + 1)}{(q^4 - 1)(q^2 - 1)(q-1)^4} \\ \tilde{\mathcal{W}}_{(1),(1),(2,2)}(q) &= \mathcal{W}_{(1),(1),(2,2)}(q) = \frac{q(q^8 - 2q^6 + q^5 + q^4 + q^3 - 2q^2 + 1)}{(q^3 - 1)(q^2 - 1)^2(q-1)^3} \\ \tilde{\mathcal{W}}_{(1),(1),(2,1,1)}(q) &= \mathcal{W}_{(1),(1),(2,1,1)}(q) \\ &= \frac{q^{10} - 2q^9 + 2q^8 - 2q^6 + 3q^5 - 2q^4 + 2q^2 - 2q + 1}{q(q^4 - 1)(q^2 - 1)(q-1)^4} \end{aligned}$$

$$\begin{aligned} \tilde{\mathcal{W}}_{(1),(1),(1,1,1,1)}(q) &= \mathcal{W}_{(1),(1),(1,1,1,1)}(q) = \frac{q^{10} - q^9 + q^5 - q + 1}{q^2(q^4 - 1)(q^3 - 1)(q^2 - 1)(q - 1)^3} \\ \tilde{\mathcal{W}}_{(1),(2),(3)}(q) &= \mathcal{W}_{(1),(2),(3)}(q) = \frac{q^2(q^{10} - q^9 + q^6 - q^4 + q^3 - q + 1)}{(q^3 - 1)(q^2 - 1)^2(q - 1)^3} \\ \tilde{\mathcal{W}}_{(1),(3),(2)}(q) &= \mathcal{W}_{(1),(3),(2)}(q) = \frac{q^2(q^{10} - q^9 + q^7 - q^6 + q^4 - q + 1)}{(q^3 - 1)(q^2 - 1)^2(q - 1)^3} \\ \tilde{\mathcal{W}}_{(1),(2),(2,1)}(q) &= \mathcal{W}_{(1),(2),(2,1)}(q) \\ &= \frac{q^{11} - 2q^{10} + 2q^9 - q^8 + q^7 - q^6 + q^4 - q + 1}{(q^3 - 1)(q^2 - 1)(q - 1)^4} \\ \tilde{\mathcal{W}}_{(1),(2,1),(2)}(q) &= \mathcal{W}_{(1),(2,1),(2)}(q) \\ &= \frac{q^{11} - q^{10} + q^7 - q^5 + q^4 - q^3 + 2q^2 - 2q + 1}{q(q^3 - 1)(q^2 - 1)(q - 1)^4} \\ \tilde{\mathcal{W}}_{(1),(2),(1,1,1)}(q) &= \mathcal{W}_{(1),(2),(1,1,1)}(q) \\ &= \frac{q^{12} - q^{11} - q^{10} + q^9 + q^8 - q^6 + q^4 - q + 1}{q(q^3 - 1)(q^2 - 1)^2(q - 1)^3} \\ \tilde{\mathcal{W}}_{(1),(1,1,1),(2)}(q) &= \mathcal{W}_{(1),(1,1,1),(2)}(q) \\ &= \frac{q^{12} - q^{11} + q^8 - q^6 + q^4 + q^3 - q^2 - q + 1}{q^3(q^3 - 1)(q^2 - 1)^2(q - 1)^3} \\ \tilde{\mathcal{W}}_{(1),(1,1),(3)}(q) &= \mathcal{W}_{(1),(1,1),(3)}(q) \\ &= \frac{q^{12} - q^{11} + q^8 - q^6 + q^4 + q^3 - q^2 - q + 1}{q(q^3 - 1)(q^2 - 1)^2(q - 1)^3} \\ \tilde{\mathcal{W}}_{(1),(3),(1,1)}(q) &= \mathcal{W}_{(1),(3),(1,1)}(q) \\ &= \frac{q(q^{12} - q^{11} - q^{10} + q^9 + q^8 - q^6 + q^4 - q + 1)}{(q^3 - 1)(q^2 - 1)^2(q - 1)^3} \\ \tilde{\mathcal{W}}_{(1),(1,1),(2,1)}(q) &= \mathcal{W}_{(1),(1,1),(2,1)}(q) \\ &= \frac{q^{11} - q^{10} + q^7 - q^5 + q^4 - q^3 + 2q^2 - 2q + 1}{q^2(q^3 - 1)(q^2 - 1)(q - 1)^4} \\ \tilde{\mathcal{W}}_{(1),(2,1),(1,1)}(q) &= \mathcal{W}_{(1),(2,1),(1,1)}(q) \\ &= \frac{q^{11} - 2q^{10} + 2q^9 - q^8 + q^7 - q^6 + q^4 - q + 1}{q(q^3 - 1)(q^2 - 1)(q - 1)^4} \\ \tilde{\mathcal{W}}_{(1),(1,1),(1,1,1)}(q) &= \mathcal{W}_{(1),(1,1),(1,1,1)}(q) = \frac{q^{10} - q^9 + q^7 - q^6 + q^4 - q + 1}{q^2(q^3 - 1)(q^2 - 1)^2(q - 1)^3} \end{aligned}$$

$$\begin{aligned}
\tilde{\mathcal{W}}_{(1),(1,1,1),(1,1)}(q) &= \mathcal{W}_{(1),(1,1,1),(1,1)}(q) = \frac{q^{10} - q^9 + q^6 - q^4 + q^3 - q + 1}{q^2(q^3 - 1)(q^2 - 1)^2(q - 1)^3} \\
\tilde{\mathcal{W}}_{(2),(2),(2)}(q) &= \mathcal{W}_{(2),(2),(2)}(q) \\
&= \frac{q(q^{10} - 3q^8 + 3q^7 + 2q^6 - 5q^5 + 2q^4 + 3q^3 - 3q^2 + 1)}{(q^2 - 1)^3(q - 1)^3} \\
\tilde{\mathcal{W}}_{(2),(2),(1,1)}(q) &= \mathcal{W}_{(2),(2),(1,1)}(q) \\
&= \frac{q^{12} - q^{11} - q^{10} + 2q^9 - q^7 + q^6 - q^5 + 2q^3 - q^2 - q + 1}{q(q^2 - 1)^3(q - 1)^3} \\
\tilde{\mathcal{W}}_{(2),(1,1),(1,1)}(q) &= \mathcal{W}_{(2),(1,1),(1,1)}(q) \\
&= \frac{q^{12} - q^{11} - q^{10} + 2q^9 - q^7 + q^6 - q^5 + 2q^3 - q^2 - q + 1}{q^2(q^2 - 1)^3(q - 1)^3} \\
\tilde{\mathcal{W}}_{(1,1),(1,1),(1,1)}(q) &= \mathcal{W}_{(1,1),(1,1),(1,1)}(q) \\
&= \frac{q^{10} - 3q^8 + 3q^7 + 2q^6 - 5q^5 + 2q^4 + 3q^3 - 3q^2 + 1}{q^2(q^2 - 1)^3(q - 1)^3} \\
\mathcal{W}_{(1),(2),(3,1)}(q) &= \tilde{\mathcal{W}}_{(1),(2),(3,1)}(q) \\
&= \frac{q^{3/2} \left(q^{13} - 2q^{12} + q^{11} + 2q^{10} - 3q^9 \right. \\
&\quad \left. + 2q^8 - 2q^6 + 2q^5 - q + 1 \right)}{(q^4 - 1)(q^2 - 1)^2(q - 1)^4} \\
\mathcal{W}_{(1,1),(2,1),(3)}(q) &= \tilde{\mathcal{W}}_{(1,1),(2,1),(3)}(q) \\
&= (q^{19} - q^{18} - q^{17} + q^{16} + q^{15} - q^{13} + q^{11} - q^{10} + q^8 + q^7 \\
&\quad - q^6 - 2q^5 + 2q^4 + q^2 - 2q + 1) \\
&\quad \cdot (q^2(q^3 - 1)^2(q^2 - 1)^2(q - 1)^4)^{-1} \\
\mathcal{W}_{(2),(2),(2,1,1,1)}(q) &= \tilde{\mathcal{W}}_{(2),(2),(2,1,1,1)}(q) \\
&= (q^{22} - q^{21} - 2q^{20} + 3q^{19} + q^{18} - 3q^{17} + 3q^{15} - q^{14} - 2q^{13} \\
&\quad + q^{12} + q^{11} + q^{10} - 2q^9 - q^8 + 3q^7 - 3q^5 + q^4 + 3q^3 \\
&\quad - 2q^2 - q + 1) \cdot (q^{7/2}(q^5 - 1)(q^3 - 1)(q^2 - 1)^3(q - 1)^4)^{-1} \\
\mathcal{W}_{(1),(2,2),(3,2)}(q) &= \tilde{\mathcal{W}}_{(1),(2,2),(3,2)}(q) \\
&= (q^{23} - 2q^{22} + q^{21} + q^{20} - q^{19} + q^{18} - 2q^{17} + q^{16} + q^{15} \\
&\quad + q^{13} - 3q^{12} + q^{10} + 2q^9 + q^8 - 2q^7 - 2q^6 + 2q^4 + 2q^3 \\
&\quad - 2q^2 - q + 1) \cdot (q(q^4 - 1)(q^3 - 1)^2(q^2 - 1)^3(q - 1)^4)^{-1}
\end{aligned}$$

Appendix Notation

$\mu = (\mu_1 \geq \dots \geq \mu_h > 0)$	partition, Section 2.1
$ \mu /\ell(\mu) / \mu^t$	size/length/transpose of a partition μ , Section 2.1
\emptyset	the empty partition, Section 2.1
$\text{Aut}(\mu)$	automorphism group of a partition μ , Section 2.1
z_μ	$\mu_1 \cdots \mu_{\ell(\mu)} \text{Aut}(\mu) $, Section 2.1
$\mathcal{P}/\mathcal{P}_+$	set of all partitions/all nonempty partitions, Section 2.1
$\mathcal{P}_+^2/\mathcal{P}_+^3$	set of pairs/triples of partitions which are not all empty, Section 2.1
$\vec{\mu} = (\mu^1, \mu^2, \mu^3)$	a triple of partitions, Section 2.1
$\ell(\vec{\mu})$	$\ell(\mu^1) + \ell(\mu^2) + \ell(\mu^3)$, Section 2.1
$\text{Aut}(\vec{\mu})$	$\text{Aut}(\mu^1) \times \text{Aut}(\mu^2) \times \text{Aut}(\mu^3)$, Section 2.1
S_d	symmetric group on d elements, Section 2.1
χ_μ	irreducible character of S_d , Section 2.1
p_i	i -th power sum $x_1^i + x_2^i + \dots$, Section 2.1
p_μ	Newton function $p_{\mu_1} p_{\mu_2} \cdots$, Section 2.1
$s_\mu/s_{\eta/\mu}$	Schur function/skew Schur function, Section 2.1
$c_{\mu\nu}^\eta$	Littlewood-Richardson coefficients, Section 2.1
$[m]$	$q^{m/2} - q^{-m/2}$, Section 2.1
κ_μ	$\sum \mu_i(\mu_i - 2i + 1)$, Section 2.1, (2-3)
$\mathcal{W}_\mu/\mathcal{W}_{\mu,v}/\mathcal{W}_{\vec{\mu}}/\tilde{\mathcal{W}}_{\vec{\mu}}$	Section 2.1, (2-4)/(2-5)/(2-6)/(2-7)
2μ	double of a partition μ , Section 2.1
$H_{\chi, \mu^+, \mu^-}^\bullet$	disconnected double Hurwitz number, Section 2.2
$\Phi_{\mu^+, \mu^-}^\bullet(\lambda)$	generating function of $H_{\chi, \mu^+, \mu^-}^\bullet$, Section 2.2
\mathbb{E}/\mathbb{L}_i	Hodge bundle/line bundles over $\overline{\mathcal{M}}_{g,n}$, Section 2.3
λ_j/ψ_i	$c_j(\mathbb{E})$ (λ -classes)/ $c_1(\mathbb{L}_i)$ (ψ -classes), Section 2.3
$\psi_i = c_1(\mathbb{L}_i)$	ψ -classes, Section 2.3
$\Lambda_g^\vee(u)$	$u^g - \lambda_1 u^{g-1} + \dots + (-1)^g \lambda_g$, Section 2.3
$G_{g, \vec{\mu}}(\mathbf{w}), G_{g, \vec{\mu}}(\tau)$	three-partition Hodge integral, Section 2.3
$G_{\vec{\mu}}, G, G_{\vec{\mu}}^\bullet, G^\bullet$	generating functions of three-partition Hodge integrals, Section 2.3
T	a rank 2 subtorus of $(\mathbb{C}^*)^3$ (so $T \cong (\mathbb{C}^*)^2$), Section 3.1
Λ_T	$\text{Hom}(T, \mathbb{C}^*)$, group of irreducible character of T (so $\Lambda_T \cong \mathbb{Z}^{\oplus 2}$), Section 3.1
$T_{\mathbb{R}}$	maximal compact subgroup of T (so $T_{\mathbb{R}} \cong U(1)^2$), Section 3.1
Γ	(FTCY) graph, Section 3.3, Definition 3.1
$E(\Gamma)/E^0(\Gamma)/V(\Gamma)$	set of edges/oriented edges/vertices of a graph Γ , Section 3.3
rev	orientation reversing map $E^0(\Gamma) \rightarrow E^0(\Gamma)$, Section 3.3, Definition 3.1
e	oriented edge, Section 3.3
$-e = \text{rev}(e)$	an oriented edge e with the opposite orientation, Section 3.3
v_0/v_1	initial/terminal vertex map $E^0(\Gamma) \rightarrow V(\Gamma)$, Section 3.3, Definition 3.1

$V_1(\Gamma)/V_2(\Gamma)/V_3(\Gamma)$	set of univalent/bivalent/trivalent vertices of Γ , Section 3.3
p/f	position/framing map, Section 3.3, Definition 3.2
l_0, l_1	maps from $E^0(\Gamma)$ to $\mathbb{Z}^{\oplus 2}$, Section 3.3, Definition 3.3
$\vec{n}(e)^e$	an integer associated to an oriented edge e , Section 3.3, Definition 3.4
$\Gamma_v/\Gamma_{e,f_0}/\Gamma^v/\Gamma^{v_1,v_2}$	smoothing/degeneration/normalization/gluing of a FTCY graph Γ , Section 3.4, Definition 3.5/3.6/3.7/3.8
Γ_A/Γ^A	smoothing/normalization of Γ along a set A of bivalent vertices, Section 3.4
$\hat{Y}^{\text{rel}} = (\hat{Y}, \hat{D})$	relative FTCY threefold associated to a FTCY graph Γ , Section 3.5
\hat{D}	relative divisor in \hat{Y} , Section 3.5
\hat{D}^v	a connected component of \hat{D} associated to a vertex v , Section 3.5
\hat{L}/\hat{L}^v	a T -invariant divisor of \hat{D}/\hat{D}^v , Section 3.5
\bar{e}	(unoriented) edge, Section 3.5
$C^{\bar{e}}$	T -invariant \mathbb{P}^1 associated to an unoriented edge \bar{e} , Section 3.5
$(\vec{d}, \vec{\mu})$	effective class, Section 4.1, Definition 4.1
$d^{\bar{e}} = \vec{d}(\bar{e})$	degree w.r.t. $C^{\bar{e}} \cong \mathbb{P}^1$, Section 4.1
$\mu^v = \vec{\mu}(v)$	ramification pattern w.r.t. the divisor $\hat{D}^v \subset \hat{Y}$, Section 4.1
$\Gamma_{\mathbf{m}}$	expanded graph, Section 4.1
$(\hat{Y}_{\mathbf{m}}, \hat{D}_{\mathbf{m}})$	relative FTCY scheme associated to the graph $\Gamma_{\mathbf{m}}$, Section 4.1
χ	$2\chi(\mathcal{O}_X)$, where X is the domain of a relative stable map, Section 4.1
$\overline{\mathcal{M}}_{\chi, \vec{d}, \vec{\mu}}^{\bullet}(\hat{Y}^{\text{rel}}, \hat{L})$	moduli stack of stable relative morphisms to \hat{Y}^{rel} , Section 4.4
$[\mathcal{T}^1 \rightarrow \mathcal{T}^2]$	perfect obstruction theory, Section 4.4
$\mathcal{T}^{i,f}/\mathcal{T}^{1,m}$	fixed/moving part of \mathcal{T}^i ($i = 1, 2$), Section 4.4
$F^{\bullet\Gamma_{\chi, \vec{d}, \vec{\mu}}}$	formal relative GW invariants of a FTCY graph Γ , Section 4.4
$\mathbf{n} = (n_1, n_2, n_3)$	framing of a topological vertex, Section 6, (6-1)
w_i/f_i	position/framing vectors of a topological vertex, Section 6, Figure 10
$F^{\bullet\vec{\chi}, \vec{\mu}}$	formal relative GW invariants of a topological vertex, Section 6, (6-2)
$\overline{\mathcal{M}}_{\vec{\chi}, \vec{\mu}}^{\bullet}(\Gamma)$	moduli stack of stable relative maps to a topological vertex, Section 6.1
$\overline{\mathcal{M}}_{\vec{\chi}, \vec{v}, \mu}^{\bullet}$	moduli stack of stable relative maps to a rubber, Section 6.1
$(\vec{\chi}, \vec{v})$	admissible label, Section 6.1/7.1, Definition 6.1/7.1
χ^i/χ^v and v^i/v^e	components of $\vec{\chi}$ and \vec{v} in $(\vec{\chi}, \vec{v})$, Section 6.1/7.1, Definition 6.1/7.1
r^v	Section 7.1, (7-1), (7-2)
$G_{\vec{\chi}, \vec{\mu}}^{\bullet}(\Gamma)/G_{\vec{\chi}, \vec{d}, \vec{\mu}}^{\bullet}(\Gamma)$	set of admissible labels of $\overline{\mathcal{M}}_{\vec{\chi}, \vec{\mu}}^{\bullet}(\Gamma)/\overline{\mathcal{M}}_{\vec{\chi}, \vec{d}, \vec{\mu}}^{\bullet}(\hat{Y}^{\text{rel}}, \hat{L})$, Section 6.1/7.1, Definition 6.1/7.1
$\overline{\mathcal{M}}_{\vec{\chi}, h}^{\bullet}$	disconnected version of $\overline{\mathcal{M}}_{g, h}$, Section 6.1
$\Lambda^{\vee}(u)$	disconnected version of $\Lambda_g^{\vee}(u)$, Section 6.1
$\mathcal{F}_{\vec{\chi}, \vec{v}}$	T fixed locus associated to the label $(\vec{\chi}, \vec{v})$, Section 6.1/7.1
$\overline{\mathcal{M}}_{\vec{\chi}, \vec{v}}$	a finite cover of $\mathcal{F}_{(\vec{\chi}, \vec{v})}$, Section 6.1/7.1
$\overline{\mathcal{M}}_{\vec{\chi}, \vec{v}}^i/\overline{\mathcal{M}}_{\vec{\chi}, \vec{v}}^v$	factors of $\overline{\mathcal{M}}_{\vec{\chi}, \vec{v}}$ (which is a product of moduli spaces), Section 6.1/7.1
$\mathbb{L}^0, \mathbb{L}^1, \mathbb{L}^{\infty}, \mathbb{L}$	line bundles on $\overline{\mathcal{M}}_{\vec{\chi}, \vec{v}, \mu}^{\bullet}$, Section 7.2
ψ^0, ψ^{∞}	target ψ -classes, Section 7.2
$J'_{\chi^v, v^e, v^{e'}}/J_{\chi^v, v^e, v^{e'}}$	Section 7.2/7.3, (7-3)/(7-4)
$V_{\vec{\chi}, \vec{v}}(\mathbf{w})/E_v(x, y)$	vertex/edge contribution to $G_{\vec{\chi}, \vec{v}}^{\bullet}(\mathbf{w})$, Section 6.2, (6-3)/(6-4)

\vec{v}^v, \mathbf{w}^v	partitions/weights of a trivalent vertex v , Section 7.3, (7-5)
$I_{\vec{\chi}, \vec{v}}$	contribution from $\mathcal{F}_{\vec{\chi}, \vec{v}}$ to the invariant $F_{\vec{\chi}, \vec{\mu}}^\bullet / F_{\vec{\chi}, d, \vec{\mu}}^{\bullet\Gamma}$, Section 6.2/7.3
$\tilde{F}_{\vec{\mu}}^\bullet / \tilde{C}_{\vec{\mu}}$	generating functions of formal relative GW invariants of a topological vertex in winding/representation basis, Section 6.3/6.4
$F_{d, \vec{\mu}}^{\bullet\Gamma} / Z_{\text{rel}}^\Gamma$	generating functions of formal relative GW invariants of a relative FTCY threefold $\hat{Y}_\Gamma^{\text{rel}}$, Section 7.4/7.7, (7-7)/(7-14)

References

- [1] **M Aganagic, A Klemm, M Mariño, C Vafa**, *The topological vertex*, Comm. Math. Phys. 254 (2005) 425–478 MR2117633
- [2] **M Aganagic, M Mariño, C Vafa**, *All loop topological string amplitudes from Chern–Simons theory*, Comm. Math. Phys. 247 (2004) 467–512 MR2063269
- [3] **K Behrend**, *Gromov–Witten invariants in algebraic geometry*, Invent. Math. 127 (1997) 601–617 MR1431140
- [4] **K Behrend, B Fantechi**, *The intrinsic normal cone*, Invent. Math. 128 (1997) 45–88 MR1437495
- [5] **D-E Diaconescu, B Florea**, *Localization and gluing of topological amplitudes*, Comm. Math. Phys. 257 (2005) 119–149 MR2163571
- [6] **D Edidin, W Graham**, *Equivariant intersection theory*, Invent. Math. 131 (1998) 595–634 MR1614555
- [7] **D Edidin, W Graham**, *Localization in equivariant intersection theory and the Bott residue formula*, Amer. J. Math. 120 (1998) 619–636 MR1623412
- [8] **IP Goulden**, *A differential operator for symmetric functions and the combinatorics of multiplying transpositions*, Trans. Amer. Math. Soc. 344 (1994) 421–440 MR1249468
- [9] **IP Goulden, DM Jackson**, *Transitive factorisations into transpositions and holomorphic mappings on the sphere*, Proc. Amer. Math. Soc. 125 (1997) 51–60 MR1396978
- [10] **IP Goulden, DM Jackson, A Vainshtein**, *The number of ramified coverings of the sphere by the torus and surfaces of higher genera*, Ann. Comb. 4 (2000) 27–46 MR1763948
- [11] **T Graber, R Pandharipande**, *Localization of virtual classes*, Invent. Math. 135 (1999) 487–518 MR1666787
- [12] **E-N Ionel, TH Parker**, *Relative Gromov–Witten invariants*, Ann. of Math. (2) 157 (2003) 45–96 MR1954264
- [13] **E-N Ionel, TH Parker**, *The symplectic sum formula for Gromov–Witten invariants*, Ann. of Math. (2) 159 (2004) 935–1025 MR2113018

- [14] **A Iqbal**, *All genus topological amplitudes and 5-brane webs as Feynman diagrams* arXiv:hep-th/0207114
- [15] **Y-H Kiem, J Li**, *Gromov–Witten invariants of varieties with holomorphic 2-forms* arXiv:0707.2986
- [16] **Y Konishi**, *Integrality of Gopakumar–Vafa invariants of toric Calabi–Yau threefolds*, Publ. Res. Inst. Math. Sci. 42 (2006) 605–648 MR2250076
- [17] **Y Konishi**, *Pole structure of topological string free energy*, Publ. Res. Inst. Math. Sci. 42 (2006) 173–219 MR2215440
- [18] **A-M Li, Y Ruan**, *Symplectic surgery and Gromov–Witten invariants of Calabi–Yau 3-folds*, Invent. Math. 145 (2001) 151–218 MR1839289
- [19] **J Li**, *Stable morphisms to singular schemes and relative stable morphisms*, J. Differential Geom. 57 (2001) 509–578 MR1882667
- [20] **J Li**, *A degeneration formula of GW-invariants*, J. Differential Geom. 60 (2002) 199–293 MR1938113
- [21] **J Li, G Tian**, *Virtual moduli cycles and Gromov–Witten invariants of algebraic varieties*, J. Amer. Math. Soc. 11 (1998) 119–174 MR1467172
- [22] **C-C M Liu, K Liu, J Zhou**, *A proof of a conjecture of Mariño–Vafa on Hodge integrals*, J. Differential Geom. 65 (2003) 289–340 MR2058264
- [23] **C-C M Liu, K Liu, J Zhou**, *A formula of two-partition Hodge integrals*, J. Amer. Math. Soc. 20 (2007) 149–184 MR2257399
- [24] **I G Macdonald**, *Symmetric functions and Hall polynomials*, second edition, Oxford Math. Monogr., Oxford Science Publ., The Clarendon Press, Oxford University Press, New York (1995) MR1354144 With contributions by A Zelevinsky
- [25] **M Mariño, C Vafa**, *Framed knots at large N* , from: “Orbifolds in mathematics and physics (Madison, WI, 2001)”, Contemp. Math. 310, Amer. Math. Soc. (2002) 185–204 MR1950947
- [26] **D Maulik, N Nekrasov, A Okounkov, R Pandharipande**, *Gromov–Witten theory and Donaldson–Thomas theory. I*, Compos. Math. 142 (2006) 1263–1285 MR2264664
- [27] **D Maulik, N Nekrasov, A Okounkov, R Pandharipande**, *Gromov–Witten theory and Donaldson–Thomas theory. II*, Compos. Math. 142 (2006) 1286–1304 MR2264665
- [28] **D Maulik, A Oblomkov, A Okounkov, R Pandharipande**, *Gromov–Witten/Donaldson–Thomas correspondence for toric 3-folds* arXiv:0809.3976
- [29] **A Okounkov, R Pandharipande**, *Hodge integrals and invariants of the unknot*, Geom. Topol. 8 (2004) 675–699 MR2057777
- [30] **A Okounkov, R Pandharipande**, *Virasoro constraints for target curves*, Invent. Math. 163 (2006) 47–108 MR2208418

- [31] **A Okounkov, N Reshetikhin, C Vafa**, *Quantum Calabi–Yau and classical crystals*, from: “The unity of mathematics”, Progr. Math. 244, Birkhäuser, Boston (2006) 597–618 MR2181817
- [32] **R Pandharipande, R P Thomas**, *The 3–fold vertex via stable pairs* arXiv:0709.3823
- [33] **R Pandharipande, R P Thomas**, *Curve counting via stable pairs in the derived category* arXiv:0707.2348
- [34] **P Peng**, *A simple proof of Gopakumar–Vafa conjecture for local toric Calabi–Yau manifolds*, Comm. Math. Phys. 276 (2007) 551–569 MR2346400
- [35] **J Zhou**, *A conjecture on Hodge integrals* arXiv:math.AG/0310282
- [36] **J Zhou**, *Curve counting and instanton counting* arXiv:math.AG/0311237
- [37] **J Zhou**, *Localizations on moduli spaces and free field realizations of Feynman rules* arXiv:math.AG/0310283

*Department of Mathematics, Stanford University
Stanford, CA 94305, USA*

*Department of Mathematics, Columbia University
New York, NY 10027, USA*

*Center of Mathematical Sciences, Zhejiang University
Hangzhou 310027, China*

*and Department of Mathematics, University of California at Los Angeles
Los Angeles, CA 90095-1555, USA*

*Department of Mathematical Sciences, Tsinghua University
Beijing 100084, China*

`jli@math.stanford.edu, ccliu@math.columbia.edu, liu@cms.zju.edu.cn,
liu@math.ucla.edu, jzhou@math.tsinghua.edu.cn`

Proposed: Jim Bryan
Seconded: Lothar Goettsche, Eleny Ionel

Received: 23 October 2007
Revised: 27 July 2008

