

# Realisation and dismantlability

SEBASTIAN HENSEL

DAMIAN OSAJDA

PIOTR PRZYTYCKI

We prove that a finite group acting on an infinite graph with dismantling properties fixes a clique. We prove that in the flag complex spanned on such a graph the fixed point set is contractible. We study dismantling properties of the arc, disc and sphere graphs. We apply our theory to prove that any finite subgroup  $H$  of the mapping class group of a surface with punctures, the handlebody group, or  $\text{Out}(F_n)$  fixes a filling (respectively simple) clique in the appropriate graph. We deduce some realisation theorems, in particular the Nielsen realisation problem in the case of a nonempty set of punctures. We also prove that infinite  $H$  have either empty or contractible fixed point sets in the corresponding complexes. Furthermore, we show that their spines are classifying spaces for proper actions for mapping class groups and  $\text{Out}(F_n)$ .

20F65

## 1 Introduction

We study *dismantlability* for infinite graphs. For a vertex  $\rho$  of a graph, its *neighbourhood*  $N(\rho)$  is the set of vertices consisting of  $\rho$  and all its neighbours. We say that a vertex  $\rho$  of a graph is *dominated* by a vertex  $\pi \neq \rho$  if  $N(\rho) \subset N(\pi)$ . A finite graph is *dismantlable* if its vertices can be ordered into a sequence  $\sigma_1, \dots, \sigma_m$  so that for each  $i < m$  the vertex  $\sigma_i$  is dominated in the subgraph induced on  $\{\sigma_i, \dots, \sigma_m\}$ . Polat [28] proved that a finite dismantlable graph contains a clique fixed by all of its automorphisms. We extend this result to infinite graphs admitting a *dismantling projection* (see Definition 2.6).

**Theorem 1.1** *Let  $H$  be a group of automorphisms of a graph  $\Gamma$  with vertex set  $V$ . Suppose that there is a  $\sigma$ -projection  $\Pi_\sigma$  and a finite  $\Pi_\sigma$ -convex subset  $R \subset V$ . Furthermore suppose that*

- (i)  $R$  is  $H$ -invariant, or
- (ii) the set  $HR$  is finite and for all  $\sigma' \in S = H\sigma \subset V$  there are  $\sigma'$ -projections  $\Pi_{\sigma'}$  for which  $R$  is  $\Pi_{\sigma'}$ -convex. Moreover, the family  $\{\Pi_{\sigma'}\}_{\sigma' \in S}$  is  $H$ -equivariant.

Then the subgraph induced on  $HR \subset V$  is dismantlable and  $\Gamma$  contains an  $H$ -invariant clique.

In the second part of the article, we generalise Polat's theorem to the following, which can be used to study fixed point sets in flag complexes spanned on finite dismantlable graphs, and on infinite graphs with dismantling projections as well.

**Theorem 1.2** *Let  $\Gamma$  be a finite dismantlable graph and let  $Y = \Gamma^\blacktriangle$ , the flag simplicial complex spanned on  $\Gamma$ . Let  $H$  be a subgroup of  $\text{Aut}(Y)$ . Then the set  $Y^H$  of points of  $Y$  fixed by  $H$  is contractible.*

Dismantlability, which should be regarded as a combinatorial nonpositive curvature feature, is shared by many graphs associated to mapping class groups and related groups. In this article, we show dismantlability for the arc graph of a punctured surface, the disc graph of a handlebody and the sphere graph of a doubled handlebody. We note that the proofs of dismantlability follow easily from the known proofs of contractibility for the arc and disc graph, but not for the sphere graph. We also prove dismantlability for the Rips graph of a hyperbolic group.

Additionally, dismantlability is known for Kakimizu graphs of link complement groups and 1-skeleta of weakly systolic complexes. In [29] we used the Kakimizu graph to prove a fixed point theorem for finite subgroups of link complements. We proved a weakly systolic fixed point theorem in [5].

Consequently, Theorems 1.1 and 1.2 give new, simplified proofs of various realisation results discussed below.

One of the classical problems in mapping class groups is the *Nielsen realisation problem*, which asks if a finite group of isotopy classes of homeomorphisms of a surface can be realised as an actual group of homeomorphisms. The case of a cyclic group was proved by Nielsen [26] in 1943, but the general question was only answered affirmatively in 1980 by Steven Kerckhoff, by in fact realising the isotopy classes as isometries of a suitable hyperbolic metric.

**Theorem 1.3** (Kerckhoff [17; 18]) *Let  $X$  be a connected oriented surface of finite type and negative Euler characteristic. Let  $H$  be a finite subgroup of the mapping class group  $\text{Map}(X)$ . Then  $X$  admits a complete hyperbolic metric such that  $H$  acts on  $X$  as a group of isometries.*

Kerckhoff's proof is analytic, based on proving convexity of length functions along "earthquake paths". Alternate but also involved proofs were later given by Wolpert [33] and Gabai [8].

In our article we will revisit the particular case where  $X$  has nonempty set of punctures. In that case, [Theorem 1.3](#) was proved by Zieschang [\[34\]](#) by extending Nielsen's method for cyclic groups (see also Tukia [\[31\]](#) for another approach). That simple example of a realisation problem will allow us to demonstrate our general approach to realisation.

Realisation theorems similar to [Theorem 1.3](#) are true in other contexts as well. As one example, we can consider a handlebody  $U$  instead of a surface. Its mapping class group  $\text{Map}(U)$  is called the *handlebody group*.

**Theorem 1.4** (Zimmermann [\[35\]](#)) *Let  $U$  be a connected handlebody of genus at least 2. Let  $H$  be a finite subgroup of the handlebody group  $\text{Map}(U)$ . Then there is a hyperbolic 3-manifold  $M$  that is homeomorphic to the interior of  $U$  such that  $H$  acts on  $M$  as a group of isometries.*

[Theorem 1.4](#) may be deduced from [Theorem 1.3](#) using the Marden isomorphism theorem (see [\[35\]](#)).

As a last example of realisation theorems we consider graphs. The group  $\text{Out}(F_n)$  acts by homotopy equivalences on a graph with fundamental group  $F_n$ .

**Theorem 1.5** (Zimmermann [\[36\]](#), Culler [\[6\]](#), Khramtsov [\[19\]](#)) *Let  $H$  be a finite subgroup of  $\text{Out}(F_n)$ . Then there is a graph with fundamental group  $F_n$  on which  $H$  acts as a group of isometries.*

The proofs require the description of virtually free groups as graphs of finite groups.

[Theorem 1.5](#) is known to imply [Theorem 1.3](#) for punctured surfaces. Namely, a finite subgroup  $H$  of  $\text{Map}(X)$  with  $\pi_1(X) = F_n$  embeds in  $\text{Out}(F_n)$ . By [Theorem 1.5](#) the group  $H$  acts by isometries on a graph  $\Gamma$  with  $\pi_1(\Gamma) = F_n$ . One can then show that  $\Gamma$  has an  $H$ -invariant ribbon graph structure determining the action of  $H$  on  $X$ . However, to better illustrate our approach, we will treat [Theorem 1.3](#) separately.

The purpose of this article is to develop a unified and elementary combinatorial approach to such realisation problems. We give proofs of [Theorem 1.4](#) and [Theorem 1.5](#) in full generality, and we also prove [Theorem 1.3](#) under any of the following hypotheses:

- (A) The set of punctures of  $X$  is nonempty.
- (B) There is a nonempty set of disjoint essential simple closed curves on  $X$  that is  $H$ -invariant up to homotopy.

Our method is elementary and consists in finding the fixed point of the action of  $H$  on the arc graph (resp. the disc graph, the sphere graph).

**Metatheorem A** *Let  $\Gamma$  be the arc graph (resp. the disc graph, the sphere graph). Then any finite subgroup of the mapping class group (resp. the handlebody group,  $\text{Out}(F_n)$ ) fixes*

- (1) *a clique in  $\Gamma$ ,*
- (2) *a filling (resp. simple) clique in  $\Gamma$ .*

Assertion (2) of [Metatheorem A](#) is stronger than (1), but in order to prove (2), we first prove (1) and then apply induction. To prove (1), the first step is to use an easy surgery procedure to show that the graph  $\Gamma$  admits dismantling projections. We then show that, even though  $\Gamma$  is locally infinite, an orbit of a finite subgroup of the ambient group extends to a finite invariant convex subset. By [Theorem 1.1](#) it contains a fixed clique.

[Theorem 1.2](#) leads to the following metatheorems.

**Metatheorem B** *Let  $H$  be any subgroup of the mapping class group (resp. the handlebody group,  $\text{Out}(F_n)$ ). The fixed point set of the action of  $H$  on the arc complex (resp. the disc complex, the sphere complex) is empty or contractible.*

In the case where  $H$  is the trivial group, [Metatheorem B](#) implies that the arc, disc and sphere complexes are contractible. These facts were known before; see Harer [11], Hatcher [13; 14] and McCullough [23]. For general  $H$  the results in [Metatheorem B](#) are new. In particular for  $H$  finite, in view of [Metatheorem A\(1\)](#), the fixed point set of  $H$  is contractible.

The following builds on and generalises [Metatheorem A\(2\)](#).

**Metatheorem C** *Let  $H$  be a finite subgroup of the mapping class group (resp. the handlebody group,  $\text{Out}(F_n)$ ). The fixed point set of the action of  $H$  on the filling arc system complex (resp. the simple disc system complex, the simple sphere system complex) is contractible.*

Consequently the filling arc system complex, as well as the simple sphere system complex, are finite models for  $\underline{EG}$ ; the classifying space for proper actions for the ambient group  $G$ . This was known for  $\text{Out}(F_n)$  (White [32], Krstić and Vogtmann [20]) for which the corresponding complex is the spine of the Outer space [14]. For the handlebody group, [Metatheorem C](#) is new. When  $G$  is the mapping class group, [Metatheorem C](#) can be obtained alternatively from the following argument pointed out to us by Mladen Bestvina and Martin Bridson. In the case of a surface with one puncture, the filling arc system complex coincides with Harer's spine of the Teichmüller space (Harer [12]). In the case of more punctures, one needs to discuss the *decorated*

Teichmüller space obtained by multiplying by a simplex. By a theorem of Penner [27], and Bowditch and Epstein [2], the decorated Teichmüller space is homeomorphic equivariantly to the arc complex minus the simplices spanned on non-filling cliques. This space naturally (hence equivariantly) retracts onto the filling arc system complex. Hence the fixed point set in the latter is contractible as the retract of the contractible fixed point set in the decorated Teichmüller space. Other finite models for  $\underline{EG}$  were constructed in Ji and Wolpert [15] and Mislin [25]. Our method also reproves that Harer's spine is in general a model for  $\underline{EG}$ , where  $G$  is the pure mapping class group.

**Theorem 1.2** can be applied in many other situations. In particular it can be used to show contractibility of sets of fixed points for weakly systolic complexes (cf [5]) or for Kakimizu complexes (cf [29]). In our article we show how to deduce from **Theorem 1.2** a new proof of the following classical result.

**Theorem 1.6** (Meintrup and Schick [24, Theorem 1]) *Let  $G$  be a  $\delta$ -hyperbolic group and let  $D \geq 8\delta + 1$ . Then the Rips complex  $P_D(G)$  is a finite model for  $\underline{EG}$ .*

We believe that many simplicial complexes appearing elsewhere in the literature can be studied using dismantlability and we intend to continue developing this approach.

## Organisation

The article is divided into two parts. In Sections 2–8 we prove **Metatheorem A** and deduce realisation results. In Sections 9–12 we prove **Metatheorems B** and **C**. Each part is precluded by a graph-theoretic section (Sections 2 and 9).

In **Section 2** we discuss the notion of dismantlability. We include the proof of Polat's theorem (**Theorem 2.4** in the text) and deduce **Theorem 1.1**, the fixed clique criterion, which will be used for **Metatheorem A(1)**. In **Section 3** we prove **Metatheorem A(1)** for the mapping class group (**Theorem 3.1**). In **Section 4** we deduce from this **Metatheorem A(2)** for the mapping class group (**Theorem 4.1**) and **Theorem 1.3** under hypothesis (A) or (B).

In **Section 5** we prove **Metatheorem A(1)** for the handlebody group (**Theorem 5.1**). In **Section 6** we derive **Metatheorem A(2)** for the handlebody group (**Theorem 6.1**) and **Theorem 1.4**. Similarly, we prove **Metatheorem A(1)** for  $\text{Out}(F_n)$  (**Theorem 7.1**) in **Section 7** and promote it to **Metatheorem A(2)** for  $\text{Out}(F_n)$  (**Theorem 8.1**) and to **Theorem 1.5** in **Section 8**.

The second part of the article begins with **Section 9**, where we prove **Theorem 1.2**. This section can be read, alternatively, directly as a continuation of **Section 2**. In **Section 10** we deduce from **Theorem 1.2** the results of **Metatheorems B** and **C** for the mapping

class group (Theorems 10.1 and 10.3). We do the same for the handlebody group and  $\text{Out}(F_n)$  in Section 11 (Theorems 11.1, 11.2, 11.3, and 11.4). Consequently, we obtain finite models for classifying spaces for proper actions in Corollaries 10.4, 10.5, and 11.5. We close the article with the proof of Theorem 1.6 in Section 12.

## Acknowledgements

We would like to thank Victor Chepoi, Saul Schleimer, Alessandro Sisto, Pekka Tukia and Karen Vogtmann for discussions, and Mladen Bestvina, Martin Bridson, Dawid Kielak and Michał Kukiela for suggestions on how to improve the article. We thank the Mittag–Leffler Institute, where a large part of this work was carried out, for its hospitality and a great working atmosphere.

Damian Osajda and Piotr Przytycki were partially supported by MNiSW grant N N201 541738 and National Science Centre DEC-2012/06/A/ST1/00259. Piotr Przytycki was also partially supported by the Foundation for Polish Science.

## 2 Dismantlability

Our goal in this section is to prove Theorem 1.1. In this theorem we require the existence of “projections” and finite sets that are “convex” under sufficiently many of these projections. Theorem 1.1 will be used to obtain Metatheorem A(1), where the role of projections will be played by surgeries.

Our proof of Theorem 1.1 relies on Polat’s fixed point theorem for dismantlable graphs [28]. We include the proof of a special case of Polat’s theorem for the article to be self-contained. The notion of dismantlability was brought into geometric group theory by Chepoi and the second named author, and it was used in particular to prove a fixed point theorem for weakly systolic complexes [5]. Later Schultens and the third named author used it to obtain contractibility and a fixed point theorem for the Kakimizu complex [29].

The results of this section have a natural continuation and generalisation in Section 9.

Unless stated otherwise, all graphs in this article are *simple* in the sense that they do not have double edges or loops, ie, edges connecting a vertex to itself. Let  $\Gamma$  be a graph with vertex set  $V$ . A subgraph of  $\Gamma$  *induced* on a subset  $V' \subset V$  has vertex set  $V'$  and all of the edges of  $\Gamma$  that connect vertices in  $V'$ .

**Definition 2.1** For a vertex  $\rho$  of a graph, its *neighbourhood*  $N(\rho)$  is the set of vertices consisting of  $\rho$  and all its neighbours. We say that a vertex  $\rho$  of a graph is *dominated* by a (*dominating*) vertex  $\pi \neq \rho$  if  $N(\rho) \subset N(\pi)$ . The symbol  $\subset$  here allows equality.

A finite graph is *dismantlable* if its vertices can be ordered into a sequence  $\sigma_1, \dots, \sigma_m$  so that for each  $i < m$  the vertex  $\sigma_i$  is dominated in the subgraph induced on  $\{\sigma_i, \dots, \sigma_m\}$ . We call such an order a *dismantling order*.

**Definition 2.2** A *clique* in a graph is a nonempty subgraph all of whose vertices are pairwise connected by edges. The vertex set of a clique is called a *clique* as well.

For a graph  $\Gamma$  let  $\Gamma^\blacktriangle$  denote the simplicial complex with 1-skeleton  $\Gamma$  and simplices spanned on all cliques in  $\Gamma$ . A simplicial complex  $Y$  is *flag* if  $Y = \Gamma^\blacktriangle$ , where  $\Gamma$  is the 1-skeleton of  $Y$ . If  $S$  is a subset of the vertex set of  $\Gamma$ , then  $S^\blacktriangle$  denotes the subcomplex of  $\Gamma^\blacktriangle$  spanned on  $S$ .

**Remark 2.3** If a finite graph  $\Gamma$  is dismantlable, then  $\Gamma^\blacktriangle$  is contractible. This will be generalised in [Section 9](#), where we prove contractibility of fixed point sets of group actions.

We build on the following special case of a result of Polat (who proves an analogue for some infinite graphs).

**Theorem 2.4** [[28](#), Theorem A] *A finite dismantlable graph contains a clique invariant under all of its automorphisms.*

Note that there are finite group actions on finite contractible or even collapsible simplicial complexes with no fixed points. Dismantlability seems to be the correct strengthening of those notions.

For completeness, we include a concise proof of [Theorem 2.4](#). Roughly speaking, the invariant clique is obtained by successively removing simultaneously all dominated vertices.

**Lemma 2.5** *If a finite graph with vertex set  $V$  is dismantlable and  $\sigma \in V$  is dominated, then the subgraph induced on  $V \setminus \{\sigma\}$  is dismantlable as well.*

**Proof** By dismantlability, we can order the vertices of  $V$  into a sequence  $\sigma_1, \dots, \sigma_m$  so that for each  $i < m$  the vertex  $\sigma_i$  is dominated in the subgraph induced on  $V^i = \{\sigma_i, \dots, \sigma_m\}$  by some  $\sigma_{f(i)}$  with  $f(i) > i$ . Assume that  $\sigma = \sigma_j$  is dominated in  $V$  by  $\sigma_k$ . Note that we might have  $k < j$ .

Let  $k_1 = k$ . For  $i = 2, \dots, j$ , define  $k_i = k_{i-1}$  if  $k_{i-1} \neq i - 1$  and  $k_i = f(k_{i-1})$  otherwise. Observe that  $k_i \geq i$  and  $N(\sigma_{k_i}) \cap V^i \supset N(\sigma_j) \cap V^i$ .

First assume that there is no  $i$  with  $k_i = j$ . In that case we induce an order on  $V \setminus \{\sigma\}$  from  $V$  and put  $f'(i) = f(i)$  if  $f(i) \neq j$  and  $f'(i) = k_i$  otherwise. Let  $i < m$  be distinct from  $j$ . Then  $\sigma_i$  is dominated in the subgraph induced on  $V^i \setminus \{\sigma\}$  by  $\sigma_{f'(i)}$ . Hence this is a dismantling order.

If  $l$  is minimal with  $k_{l+1} = j$ , then  $k_l = l$  and we have  $N(\sigma_l) \cap V^l = N(\sigma_j) \cap V^l$ . Hence the subgraph induced on  $V^l \setminus \{\sigma\}$  is isomorphic to the subgraph induced on  $V^{l+1}$ , which was dismantlable. Then in the order on  $V \setminus \{\sigma\}$  induced from  $V$ , we carry  $\sigma_l$  to the position  $j$ , which was occupied in  $V$  by  $\sigma$ . For every  $i < l$ , the vertex  $\sigma_i$  is dominated in the subgraph induced on  $V^i \setminus \{\sigma\}$  by  $\sigma_{f'(i)}$ , as before.  $\square$

**Proof of Theorem 2.4** The proof is by induction on the number of vertices. If the graph consists of one vertex, the theorem is trivial. Now assume we have a dismantlable graph  $\Gamma$  with vertex set  $V$  and the theorem is true for all graphs with fewer vertices. We treat two cases separately.

**Case 1** There are no two vertices  $\sigma, \rho \in V$  with  $N(\sigma) = N(\rho)$ . In this case, let  $V' \subset V$  be the set of all dominated vertices. Note that each vertex of  $V'$  is dominated by a vertex in  $V \setminus V'$ . Let  $\Gamma'$  be the subgraph of  $\Gamma$  induced on  $V \setminus V'$ . Note that every automorphism of  $\Gamma$  restricts to an automorphism of  $\Gamma'$ . Since  $\Gamma'$  is obtained from  $\Gamma$  by repeatedly removing dominated vertices, by Lemma 2.5 the graph  $\Gamma'$  is dismantlable. By induction hypothesis, there is a clique  $\Delta'$  in  $\Gamma'$  invariant under every automorphism of  $\Gamma'$ . The clique  $\Delta'$  is then also invariant under every automorphism of  $\Gamma$ .

**Case 2** There are vertices  $\sigma, \rho \in V$  with  $N(\sigma) = N(\rho)$ . In this case, let  $\Gamma'$  be the graph obtained from  $\Gamma$  by identifying all vertices  $\sigma$  with common  $N(\sigma)$  (and identifying the double edges and removing loops). More precisely, we consider the equivalence relation  $\sim$  on  $V$  for which  $\sigma \sim \rho$  if and only if  $N(\sigma) = N(\rho)$ . Equivalence classes of  $\sim$  are cliques. The vertex set of  $\Gamma'$  is the set of equivalence classes of  $\sim$ . Two vertices of  $\Gamma'$  are connected by an edge if some (hence any) of its representatives in  $\Gamma$  are connected by an edge.

Note that every automorphism of  $\Gamma$  projects to an automorphism of  $\Gamma'$ . Moreover,  $\Gamma'$  can be embedded as an induced subgraph in  $\Gamma$  and obtained from  $\Gamma$  by repeatedly removing dominated vertices. Again, by Lemma 2.5 the graph  $\Gamma'$  is dismantlable and by induction hypothesis there is a clique  $\Delta'$  in  $\Gamma'$  invariant under every automorphism of  $\Gamma'$ . Hence its preimage  $\Delta$  under the projection from  $\Gamma$  is a clique invariant under every automorphism of  $\Gamma$ .  $\square$

Dismantlability can be verified if we have particular “projection” maps.



**Definition 2.6** Consider a graph with vertex set  $V$ . Let  $\sigma \in V$  and let  $\Pi$  assign to each vertex  $\rho \in V \setminus \{\sigma\}$  a nonempty finite set  $\Pi(\rho)$  consisting of pairs of elements of  $V$ . We allow the two elements of a pair to coincide. Let  $\Pi^*(\rho) \subset V$  denote the set of all vertices appearing in pairs from  $\Pi(\rho)$ .

We call  $\Pi$  a  $\sigma$ -projection (or a dismantling projection if  $\sigma$  is not specified) if the following axioms are satisfied:

- (i) For each finite set of vertices  $R \subset V$  with nonempty  $R \setminus \{\sigma\}$ , there is an exposed vertex  $\rho \in R \setminus \{\sigma\}$ , that is, a vertex with  $N(\rho) \cap R \subset N(\pi)$  for both  $\pi$  from some pair of  $\Pi(\rho)$ .
- (ii) There is no cycle of vertices  $\rho_0, \dots, \rho_{m-1} \in V$  with  $\rho_{i+1} \in \Pi^*(\rho_i)$ , where  $i$  is considered modulo  $m$ .

Note that axiom (ii) implies in particular that  $\rho \notin \Pi^*(\rho)$ .

**Lemma 2.7** A finite graph with a dismantling projection is dismantlable.

Before we provide the proof of Lemma 2.7, we deduce a corollary.

**Definition 2.8** Consider a graph with vertex set  $V$  and a  $\sigma$ -projection  $\Pi$ . We say that a nonempty subset  $R \subset V$  is  $\Pi$ -convex if for every vertex  $\rho \in R \setminus \{\sigma\}$  each pair in  $\Pi(\rho)$  intersects  $R$ .

We will see in a moment that if  $R$  is  $\Pi$ -convex for a  $\sigma$ -projection  $\Pi$ , then  $\sigma \in R$ .

**Corollary 2.9** Let  $\Gamma$  be a graph with a dismantling projection  $\Pi$  and a finite  $\Pi$ -convex subset  $R$  of its vertices. Then the subgraph of  $\Gamma$  induced on  $R$  is dismantlable.

**Proof** Suppose  $\Pi$  is a  $\sigma$ -projection. For any pair  $P$  intersecting  $R$  consider  $P \cap R$  as a pair (of possibly two coinciding elements). Let  $\Pi^R$  assign to any  $\rho \in R \setminus \{\sigma\}$  the set of pairs  $P \cap R$  over  $P \in \Pi(\rho)$ . The assignment  $\Pi^R$  satisfies axioms (i) and (ii) of a  $\sigma$ -projection for the induced subgraph. The only non-immediate part is to verify  $\sigma \in R$ , which can be deduced from axiom (ii): we consider the longest sequence  $\rho_0, \dots, \rho_m \in R$  with  $\rho_{i+1} \in \Pi^*(\rho_i)$ . Since the only vertex on which  $\Pi^R$  might not be defined is  $\sigma$ , we have  $\rho_m = \sigma$ . □

**Proof of Lemma 2.7** Let  $m$  denote the cardinality of the vertex set  $V$  of the graph. Suppose the dismantling projection  $\Pi$  is a  $\sigma$ -projection. Define inductively  $\sigma_i$  for  $i = 1, \dots, m - 1$  so that  $\sigma_i$  is exposed (see axiom (i) of a  $\sigma$ -projection) in the set

$V^i = V \setminus \{\sigma_1, \dots, \sigma_{i-1}\}$  and put  $\sigma_m = \sigma$ . We will verify that this is a dismantling order. Since the  $\sigma_i$  are exposed, there are vertices  $\pi_1^1, \dots, \pi_{m-1}^1$  in  $\Pi^*(\sigma_1), \dots, \Pi^*(\sigma_{m-1})$  satisfying  $N(\sigma_i) \cap V^i \subset N(\pi_i^1)$ .

By construction, the vertex  $\sigma_1$  is dominated in  $V^1 = V$  by  $\pi_1^1$ . However, the vertices  $\sigma_i$  for  $i > 1$  might not be dominated in  $V^i$  by  $\pi_i^1$  if the latter lie outside  $V^i$ . This might happen if, for some  $j < i$ ,  $\sigma_j$  is chosen to be  $\pi_i^1$ . However, in that case we can replace  $\pi_i^1$  with  $\pi_j^1$ , if the latter is in  $V^i$ , or else with yet another vertex. Here is the systematic way to determine this choice.

By axiom (ii) of a  $\sigma$ -projection, the directed graph with vertices  $V = V^1$  and edges  $\{(\sigma_j, \pi_j^1)\}_{j=1}^{m-1}$  has no directed cycles. For  $i = 2, \dots, m - 1$ , inductively define  $\pi_j^i$ , where  $j = i, i + 1, \dots, m - 1$  so that  $\pi_j^i = \pi_j^{i-1}$  if  $\pi_j^{i-1} \neq \sigma_{i-1}$ , and  $\pi_j^i = \pi_{i-1}^{i-1}$  otherwise. We inductively see that in both cases  $\pi_j^i \in V^i$  and the directed graph with vertices  $V^i$  and edges  $\{(\sigma_j, \pi_j^i)\}_{j=i}^{m-1}$  has no directed cycles. We also claim the following, which we will prove by induction on  $i = 1, \dots, m - 1$ :

- (a)  $N(\pi_i^1) \cap V^i \subset N(\pi_i^i)$ .
- (b)  $N(\sigma_i) \cap V^i \subset N(\pi_i^i)$ .
- (c)  $N(\pi_j^i) \cap V^{i+1} \subset N(\pi_j^{i+1})$  for  $j = i + 1, \dots, m - 1$ .

Note that part (b) means that  $\sigma_i$  is dominated in  $V^i$ , which implies dismantlability.

First observe that part (a) implies part (b) by the choice of  $\pi_i^1$ . Also note that part (b) directly implies part (c) since, in the case where  $\pi_j^{i+1} = \pi_j^i$ , there is nothing to prove, and otherwise,  $\pi_j^i = \sigma_i$  and  $\pi_j^{i+1} = \pi_i^i$ . Finally, part (a) for  $i = k$  follows from applying  $k - 1$  times part (c) with  $j = k$  and  $i = 1, \dots, k - 1$ . □

We are now in position to prove our main criterion for the existence of an invariant clique.

**Definition 2.10** Let  $H$  be a finite group of automorphisms of a graph with vertex set  $V$ . A family of  $\sigma$ -projections  $\{\Pi_\sigma\}_{\sigma \in S}$  with  $S \subset V$  is  $H$ -equivariant if  $S$  is  $H$ -invariant and

$$h\Pi_\sigma(\rho) = \Pi_{h\sigma}(h\rho)$$

for all  $\sigma \in S$ ,  $\rho \in V$  and  $h \in H$ .

**Proof of Theorem 1.1** Under hypothesis (i) the theorem follows directly from [Corollary 2.9](#) and [Theorem 2.4](#).

Under hypothesis (ii), let  $T = HR \subset V$ . Then the subgraph induced on the finite vertex set  $T$  is  $H$ -invariant and we want to reduce to hypothesis (i) with  $T$  in place of  $R$ . Let  $\tau \in T \setminus \{\sigma\}$ . Then  $\tau = h\rho$  for some  $\rho \in R$ ,  $h \in H$ . Let  $P$  be a pair in  $\Pi_\sigma(\tau) = \Pi_{hh^{-1}\sigma}(h\rho)$ . Then  $h^{-1}(P)$  is a pair in  $\Pi_{h^{-1}\sigma}(\rho)$ . Since  $h^{-1}\sigma \in S$  the set  $R$  is  $\Pi_{h^{-1}\sigma}$ -convex. Then  $h^{-1}(P) \cap R$  is nonempty and hence  $h^{-1}(P) \cap T$  is nonempty. Since  $T = h^{-1}T$  we have  $P \cap T \neq \emptyset$ , as desired.  $\square$

We conclude this section by posing a question concerning infinite graphs. An affirmative answer to it would significantly simplify the proofs of our realisation results and of similar results in future. Define an infinite graph  $\Gamma$  to be *dismantlable* if the following holds: every finite set of vertices of  $\Gamma$  is contained in another finite set of vertices  $S$  such that the finite subgraph induced on  $S$  is dismantlable.

**Question 2.11** Let  $H$  be a finite group of automorphisms of a dismantlable graph  $\Gamma$  with a uniform bound on the size of cliques. Does  $\Gamma$  contain an  $H$ -invariant clique?

The assumption on the size of cliques is necessary, as pointed out to us by Dawid Kielak and Michał Kukuła. Note that there are many ways of defining dismantlability for infinite graphs and the definition above is just the weakest version we have in mind at the moment.

### 3 Fixed clique in the arc graph

In this section, we prove [Metatheorem A\(1\)](#) in the case of the arc graph. Let  $X$  be a (possibly disconnected) closed oriented surface with a nonempty finite set  $\mu$  of *marked points* on  $X$ . We require that homeomorphisms and homotopies of  $X$  fix  $\mu$ . The *Euler characteristic* of  $X$  is defined to be the Euler characteristic of  $X - \mu$ .

A *simple arc* on  $X$  is an embedding of an open interval in  $X - \mu$  that can be extended to map the endpoints into  $\mu$ . We require that homotopies of arcs fix the endpoints and do not pass over marked points. An arc is *essential* if it is not homotopic into  $\mu$ . Unless stated otherwise, all arcs are assumed to be simple and essential.

The *arc graph*  $\mathcal{A}(X)$  is the graph whose vertex set  $\mathcal{A}^0(X)$  is the set of homotopy classes of arcs. Two vertices are connected by an edge in  $\mathcal{A}(X)$  if the corresponding arcs can be realised disjointly.

By  $\text{Map}(X)$  we denote the *mapping class group* of  $X$ , which is the group of orientation-preserving homeomorphisms of  $X$  up to isotopy. The action of  $\text{Map}(X)$  on homotopy classes of arcs induces an action of  $\text{Map}(X)$  on  $\mathcal{A}(X)$  as a group of automorphisms. We can now state the main theorem of this section.

**Theorem 3.1** *Let  $X$  be a closed oriented surface with a nonempty set of marked points, each component of which has negative Euler characteristic. Let  $H$  be a finite subgroup of  $\text{Map}(X)$ . Then  $H$  fixes a clique in the arc graph  $\mathcal{A}(X)$ .*

We will obtain [Theorem 3.1](#) using [Theorem 1.1](#) under hypothesis (ii). For that we need two elements: on the one hand, we will use a surgery procedure for arcs to define dismantling projections  $\Pi_\sigma$  (see [Section 3.1](#)). On the other hand, we will define a finite set in the arc graph that is  $\Pi_\sigma$ -convex for all  $\sigma$  in some  $H$ -orbit (see [Section 3.2](#)).

### 3.1 Arc surgery

We begin by describing the surgery procedure that will be used to define the dismantling projections. This surgery procedure was used by Hatcher [[13](#)] to show contractibility of the arc complex.

Let  $a$  and  $a'$  be two arcs on  $X$ . We say that  $a$  and  $a'$  are in *minimal position* if the number of intersections between  $a$  and  $a'$  is minimal in the homotopy classes of  $a$  and  $a'$ .

Now assume that  $a$  and  $a'$  are in minimal position and suppose that  $a$  and  $a'$  intersect. We say that a subarc  $b \subset a$  is *outermost in  $a$  for  $a'$*  if  $b$  is a component of  $a - a'$  sharing an endpoint with  $a$ . There are two outermost subarcs in  $a$  for  $a'$ .

Consider an outermost subarc  $b$  in  $a$  for  $a'$ . Let  $p$  be the endpoint of  $b$  in the interior of  $a$ . Then  $p \in a'$ . Let  $b'_+$ ,  $b'_-$  be the two components of  $a' - p$ . We say that the arcs  $a'_+ = b \cup b'_+$  and  $a'_- = b \cup b'_-$  are obtained by *outermost surgery of  $a'$  in the direction of  $a$  determined by  $b$*  (see [Figure 1](#)). Both  $a'_+$  and  $a'_-$  are essential, since  $a$  and  $a'$  are in minimal position. Furthermore, both  $a'_+$  and  $a'_-$  are disjoint from  $a'$  up to homotopy.

Note that the homotopy classes  $\alpha'_+$  of  $a'_+$  and  $\alpha'_-$  of  $a'_-$  depend only on the homotopy classes  $\alpha$  of  $a$  and  $\alpha'$  of  $a'$ . We call the pair  $\{\alpha'_+, \alpha'_-\}$  an *outermost surgery pair of  $\alpha'$  in the direction of  $\alpha$* .

If  $\alpha'$  is disjoint from  $\alpha$  (but distinct), then we say that the only *outermost surgery pair of  $\alpha'$  in the direction of  $\alpha$*  is  $\{\alpha, \alpha\}$ , interpreted as a pair whose elements are both equal to  $\alpha$ . Let  $\Pi_\alpha(\alpha')$  be the set of all (two or one) outermost surgery pairs of  $\alpha'$  in the direction of  $\alpha$ . If  $\alpha' = \alpha$ , then  $\Pi_\alpha(\alpha')$  is undefined.

The following lemma states that the assignment  $\Pi_\sigma$  satisfies the axioms of a  $\sigma$ -projection for each  $\sigma \in \mathcal{A}^0(X)$ . This lemma was essentially proved as Claim 3.18 of Schleimer [[30](#)].

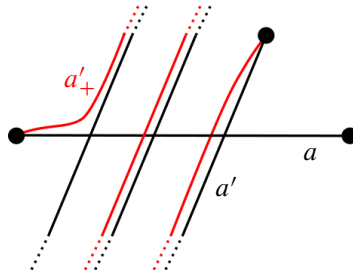

Figure 1: Surgery for arcs

**Lemma 3.2** *Let  $\sigma \in \mathcal{A}^0(X)$  be an arc on  $X$ .*

- (i) *Let  $R \subset \mathcal{A}^0(X)$  be a finite set of arcs with  $R \setminus \{\sigma\} \neq \emptyset$ . Then there is an arc  $\rho \in R \setminus \{\sigma\}$  with the following property: there is an outermost surgery pair  $\{\rho_+, \rho_-\}$  of  $\rho$  in the direction of  $\sigma$ , such that each arc  $\rho' \in R$  that is disjoint from  $\rho$  is also disjoint from  $\rho_+$  and  $\rho_-$ .*
- (ii) *Every sequence  $(\rho_i)$  of arcs in  $\mathcal{A}^0(X)$  such that  $\rho_{i+1}$  is contained in an outermost surgery pair of  $\rho_i$  in the direction of  $\sigma$  terminates, after finitely many steps, with the arc  $\sigma$ .*

The proof requires us to consistently choose preferred representatives for each homotopy class of arcs. This is made possible through the use of hyperbolic geometry. To this end, it is convenient to adopt a slightly different description of the arc graph of  $X$ . Namely, let  $\check{X}$  be the compact surface obtained from  $X$  by replacing each marked point with a boundary component. Let  $\mathcal{A}(\check{X})$  be the graph whose vertex set is the set of homotopy classes of (essential simple) arcs on  $\check{X}$  that are embedded *properly*, ie they intersect the boundary exactly at the endpoints. Homotopies of arcs on  $\check{X}$  are required to be homotopies of properly embedded arcs. Two vertices are connected by an edge if the corresponding arcs may be realised disjointly. Since homotopy classes of (properly embedded) arcs on  $\check{X}$  are in one-to-one correspondence with homotopy classes of arcs on  $X$  respecting disjointness, the graph  $\mathcal{A}(\check{X})$  is isomorphic to  $\mathcal{A}(X)$ . We will implicitly use this identification, and simply speak about representatives of arcs  $\rho \in \mathcal{A}^0(X)$  on  $\check{X}$ .

We now fix a hyperbolic metric on  $\check{X}$  that makes the boundary geodesic. Then each homotopy class of an arc contains a unique shortest geodesic representative, and any two such representatives are in minimal position (see the discussion in Farb and Margalit [7, Section 1.2.7]).

**Proof of Lemma 3.2** (i) We can assume that not all the arcs in  $R$  are disjoint from  $\sigma$ , since otherwise the assertion follows trivially. Denote the shortest geodesic

representatives on  $\check{X}$  of the elements of  $R$  by  $r_1, \dots, r_k$ , and the shortest geodesic representative of  $\sigma$  by  $s$ . Let  $b \subset s$  be a component of  $s - (r_1 \cup \dots \cup r_k)$  sharing an endpoint with  $s$ . Denote by  $p$  the endpoint of  $b$  in the interior of  $s$ . Let  $r$  be an arc in  $R$  containing  $p$ . Suppose  $r_*$  is obtained by outermost surgery of  $r$  in the direction of  $s$  determined by  $b$ . Now let  $r_i$  be disjoint from  $r$ . Since  $r_i$  is disjoint from  $b$ , it is also disjoint from  $r_* \subset r \cup b$ , as desired.

(ii) By construction, each outermost surgery strictly decreases the geometric intersection number with  $\sigma$ . Hence every sequence of surgeries eventually yields an arc that is disjoint from  $\sigma$ . □

For future reference, we also note the following easy fact.

**Lemma 3.3** *For every  $h \in \text{Map}(X)$ , we have  $h\Pi_\sigma(\rho) = \Pi_{h\sigma}(h\rho)$  for all arcs  $\sigma \neq \rho \in \mathcal{A}^0(X)$ .*

**Proof** Let  $s, r$  be representatives of  $\sigma$  and  $\rho$  that are in minimal position. Let  $\check{h}: X \rightarrow X$  be a representative of the mapping class  $h$ . Then  $\check{h}(s)$  and  $\check{h}(r)$  are in minimal position, and  $\check{h}$  maps an outermost subarc in  $s$  for  $r$  to an outermost subarc in  $\check{h}(s)$  for  $\check{h}(r)$ . □

### 3.2 Finite hull for arcs

We now describe how a finite vertex set  $\alpha_1, \dots, \alpha_k \in \mathcal{A}^0(X)$  can be extended to a finite set that is  $\Pi_\sigma$ -convex for all  $\sigma = \alpha_i$ .

Let  $\alpha_1, \dots, \alpha_k \in \mathcal{A}^0(X)$  be an arbitrary finite set of arcs, and let  $a_1, \dots, a_k$  be their shortest geodesic representatives on  $\check{X}$ . Let  $L$  be the maximum of the lengths of the  $a_i$ .

We define  $\mathcal{H} = \mathcal{H}(\alpha_1, \dots, \alpha_k)$  to be the set of homotopy classes of arcs that have a representative of length at most  $2L$  on  $\check{X}$ . The set  $\mathcal{H}$  is finite, and contains  $\alpha_1, \dots, \alpha_k$  by construction. However, note that the set  $\mathcal{H}$  depends on the choice of the hyperbolic metric.

**Lemma 3.4** *Let  $\alpha_1, \dots, \alpha_k \in \mathcal{A}^0(X)$  be a finite set of arcs. Put  $\alpha = \alpha_i$  for some  $i = 1, \dots, k$ , and let  $\alpha' \in \mathcal{H} = \mathcal{H}(\alpha_1, \dots, \alpha_k)$  be arbitrary. Then each outermost surgery pair of  $\alpha'$  in the direction of  $\alpha$  contains at least one element of  $\mathcal{H}$ .*

**Proof** Let  $a'$  be the shortest geodesic representative of  $\alpha'$  and let  $a$  be the shortest geodesic representative of  $\alpha = \alpha_i$ . We can assume that  $a$  and  $a'$  intersect.

Then an outermost subarc  $b$  in  $a$  for  $a'$  has length at most  $L$  by the definition of  $L$ . Let  $b'_+$ ,  $b'_-$  be the two subarcs of  $a'$  bounded by the endpoint of  $b$ . Then at least one of  $b'_+$ ,  $b'_-$  has length at most  $L$ , say  $b'_+$ . As a consequence, the arc  $a'_+ = b \cup b'_+$  has length at most  $2L$ , and thus its homotopy class is contained in  $\mathcal{H}$ .  $\square$

We are now in position to prove [Theorem 3.1](#).

**Proof of Theorem 3.1** By [Lemma 3.2](#) the assignment of outermost surgery pairs satisfies the axioms of a dismantling projection. Let  $\alpha_1$  be an arbitrary arc in  $\mathcal{A}^0(X)$ , and let  $\alpha_1, \dots, \alpha_k$  be the orbit of  $\alpha_1$  under  $H$ . [Lemma 3.4](#) shows that  $\mathcal{H}(\alpha_1, \dots, \alpha_k)$  is  $\Pi_{\alpha_i}$ -convex for each  $i = 1, \dots, k$ . Finally, by [Lemma 3.3](#) the family  $\Pi_{\alpha_i}$  is  $H$ -equivariant. Thus  $H$  fixes a clique by [Theorem 1.1](#) under hypothesis (ii).  $\square$

**Remark 3.5** We could also derive [Theorem 3.1](#) directly from [Theorem 1.1](#) under hypothesis (i) by considering a different finite invariant set.

Namely, define a *one-corner arc* (or a *unicorn arc*) obtained from geodesic arcs  $a_1, \dots, a_k$  to be an embedded arc  $a$  on  $\check{X}$  of the following form: there are subarcs  $a^+$ ,  $a^-$  of  $a_i, a_j$  for some  $i, j$  such that  $a = a^+ \cup a^-$ .

We then define  $\tilde{\mathcal{H}}$  to be the union of  $\{a_1, \dots, a_k\}$  and the finite set of all unicorn arcs obtained from  $a_1, \dots, a_k$ . If the set of homotopy classes of the arcs  $a_1, \dots, a_k$  is  $H$ -invariant, then the set  $\tilde{\mathcal{H}}$  is  $H$ -invariant as well. Furthermore, one can show that  $\tilde{\mathcal{H}}$  is  $\Pi_{\alpha_i}$ -convex for the homotopy classes  $\alpha_i$  of  $a_i$ . However, the proof is a bit more involved than the simple length argument used for [Lemma 3.4](#), and we decided to omit it.

## 4 Nielsen realisation for surfaces

In this section, we prove [Metatheorem A\(2\)](#) for mapping class groups ([Theorem 4.1](#)) and [Theorem 1.3](#) under either of the hypotheses (A) or (B).

### 4.1 Fixed filling arc set

A set  $A$  of disjoint (simple essential) arcs on a surface  $X$  with marked points  $\mu$  is *filling* if the components of  $X - (\mu \cup A)$  are discs. A clique  $\Delta \subset \mathcal{A}^0(X)$  is *filling* if some (hence any) set of disjoint representatives of elements in  $\Delta$  is filling.

**Theorem 4.1** *Let  $X$  be a closed connected oriented surface with nonempty set of marked points and negative Euler characteristic. Let  $H$  be a finite subgroup of  $\text{Map}(X)$ . Then  $H$  fixes a filling clique in  $\mathcal{A}^0(X)$ .*

**Proof** By [Theorem 3.1](#), there is a clique  $\Delta \subset \mathcal{A}^0(X)$  fixed by  $H$ . Assume that  $\Delta$  is a maximal clique fixed by  $H$ . We will prove that  $\Delta$  is filling. We can realise  $\Delta$  as a subset  $A \subset S$  of disjoint arcs. Equip  $X$  with a path-metric in which each arc of  $A$  has length 1. By [Buser \[4, Theorem A.5\]](#) we can also choose representatives of the elements of  $H$  fixing  $A$  and restricting to a genuine isometric action on  $A$ . Note that these representatives satisfy the composition rule up to isotopy fixing  $A$ . We will prove that  $A$  is filling.

Otherwise, let  $X_0$  be the nonempty union of open components of  $X - A$  that are not discs, ie have nonpositive Euler characteristic. Let  $\bar{X}_0$  be the path-metric completion of  $X_0$ . Let  $X'$  be the surface obtained from  $\bar{X}_0$  by collapsing each component of  $\partial\bar{X}_0$  to a marked point. The group  $H$  maps into  $\text{Map}(X')$ . Every component of  $X'$  with zero Euler characteristic is a sphere with two marked points and contains a unique (homotopy class of) an arc. In the case where  $X'$  has such components, we consider the  $H$ -invariant clique  $\Delta' \subset \mathcal{A}^0(X')$  of unique arcs in all of these components. Otherwise an  $H$ -invariant clique  $\Delta' \subset \mathcal{A}^0(X')$  exists by [Theorem 3.1](#). Denote  $\Delta' = \{\alpha'_1, \dots, \alpha'_k\}$ .

Let  $\mathcal{A}^*(X, A)$  denote the set of homotopy classes of (possibly non-simple) essential arcs on  $\bar{X}_0$  with endpoints in  $\partial\bar{X}_0$ . We require homotopies to fix the endpoints. Let  $\mathcal{P} \subset \partial\bar{X}_0$  be a family of points, one in each of the components of  $\partial\bar{X}_0$ . For  $i = 1, \dots, k$  choose arcs  $\alpha_i^*(0) \in \mathcal{A}^*(X, A)$  with endpoints  $p_i, q_i \in \mathcal{P}$  that project to  $\alpha'_i$  on  $X'$  and have representatives that are simple and disjoint outside  $\mathcal{P}$ . For a point  $p \in \partial\bar{X}_0, t \in \mathbb{R}$ , let  $\gamma^*(p, t)$  be the homotopy class of the (non-essential) arc starting at  $p$ , moving clockwise along the boundary component  $c \subset \partial\bar{X}_0$  containing  $p$  and terminating after distance  $t|c|$ , where  $|c|$  denotes the length of  $c$ . In particular for  $t \in \mathbb{Z}$ , the endpoint of  $\gamma^*(p, t)$  is  $p$ . To each point  $z = (x_1, y_1, \dots, x_k, y_k) \in \mathbb{R}^{2k}$ , we assign the following sequence  $\Delta^*(z) = (\alpha_1^*, \dots, \alpha_k^*)$  of arcs in  $\mathcal{A}^*(X, A)$ . Each  $\alpha_i^*$  is the homotopy class of the concatenation  $\gamma^*(p_i, x_i)^{-1}\alpha_i^*(0)\gamma^*(q_i, y_i)$ .

Consider first the case where all of the components of  $X'$  have negative Euler characteristic. In that case  $\Delta^*$  is injective, since Dehn twists along a pair of components of  $\partial\bar{X}_0$  are independent. Note that the set  $Z \subset \mathbb{R}^{2k}$  of points  $z$  for which  $\Delta^*(z)$  can be represented as a collection of disjoint simple arcs is nonempty, since it contains 0. We claim that  $Z$  is convex.

The arc  $\alpha_i^*$  might self-intersect only when its endpoints lie on the same component of  $\partial\bar{X}_0$ , hence only when  $p_i = q_i$ . Self-intersection of  $\alpha_i^*$  arises when, starting from  $\alpha_i^*(0)$ , the two endpoints pass through one another. This is governed, up to interchanging  $x_i$  with  $y_i$ , by the inequality  $x_i \leq y_i \leq x_i + 1$ , which is a linear constraint. The description is the same for intersections of distinct  $\alpha_i^*, \alpha_j^*$ , where



we will get a constraint for each pair of coinciding endpoints of  $\alpha_i^*(0), \alpha_j^*(0)$ . This justifies the claim.

Under the identification of  $Z$  with  $\Delta^*(Z)$ , the finite group  $H$  acts on  $Z$  by isometries (each of which is a composition of a translation and an interchange of the coordinate axes). Hence  $H$  fixes a point  $z \in Z$  (for example the centre of mass of some orbit). Let  $\varepsilon \in \mathbb{R}^{2k}$  be the vector with smallest nonnegative entries such that  $\Delta^*(z + \varepsilon)$  has endpoints in marked points of  $X$  under the map  $\bar{X}_0 \rightarrow X$ . Note that  $z + \varepsilon$  is also  $H$ -invariant. The arc set  $\Delta^*(z + \varepsilon)$  can be interpreted as a subset of  $\mathcal{A}^0(X)$ . Then  $\Delta \cup \Delta^*(z + \varepsilon)$  forms an  $H$ -invariant clique larger than  $\Delta$  and we have reached a contradiction.

In the case where  $\alpha'_i$  lie in the components of  $X'$  of zero Euler characteristic we have  $\Delta^*(z + e_{2i-1} - e_{2i}) = \Delta^*(z)$ , where  $e_i$  denotes the  $i^{\text{th}}$  basis vector of  $\mathbb{R}^{2k}$ . Arcs  $\alpha'_i$  for each of the lines  $z + te_{2i-1} - te_{2i}$  where  $t \in \mathbb{R}$  form families of parallel arcs. Each such family can be thought of as having the same “slope” in the annulus component of  $\bar{X}_0$ . After quotienting  $Z \subset \mathbb{R}^{2k}$  by all  $k$  such  $\mathbb{R}$ -actions we obtain an action of  $H$  on a convex subset of  $\mathbb{R}^k = \mathbb{R}^{2k}/\mathbb{R}^k$  of “slopes”. In the conclusion of the fixed-point theorem we obtain  $H$ -invariant “slope sets”: families of parallel arcs in the components of zero Euler characteristic. We can improve them to families of parallel arcs with endpoints in marked points as before. □

### 4.2 Fixed hyperbolic metric

**Proof of Theorem 1.3 under hypothesis (A)** By Theorem 4.1, the group  $H$  fixes a filling clique  $\Delta \subset \mathcal{A}^0(X)$ . We can realise  $\Delta$  as a set  $A$  of disjoint arcs on  $X$ . For each component  $Y$  of  $X - A$  with  $k$  arcs in its boundary, we consider a regular ideal hyperbolic  $k$ -gon  $\hat{Y}$ . For any arc  $a \in A$  adjacent to components  $Y_1, Y_2$  of  $X - A$ , we glue  $\hat{Y}_1$  with  $\hat{Y}_2$  along the sides  $\hat{A}_1 \subset \hat{Y}_1, \hat{A}_2 \subset \hat{Y}_2$  corresponding to  $a$  in such a way that the projections of the centres of  $\hat{Y}_1$  and  $\hat{Y}_2$  onto  $\hat{A}_1$  and  $\hat{A}_2$  coincide under that gluing. The hyperbolic metric on  $X - \mu$  that we obtain as a result is complete and  $H$ -invariant. □

**Proof of Theorem 1.3 under hypothesis (B)** A closed curve is *simple* if it is embedded, and *essential* if it is not homotopic to a trivial curve. We can assume that the set of marked points on  $X$  is empty. Realise the curves of the fixed set as a set  $A$  of disjoint simple curves on  $X$ . We can choose representatives of elements of  $H$  fixing  $A$  (see [4, Theorem A.3]). Let  $X'$  be obtained from  $\bar{X} - A$  by collapsing its boundary components to marked points. Denote by  $\mu'$  the set of marked points on  $X'$ . By Theorem 1.3 under hypothesis (A), there is a complete hyperbolic metric

on  $X' - \mu'$  invariant under the image of  $H$  in  $\text{Map}(X')$ . Let  $l$  be small enough so that the horocycles of length  $l$  around the punctures embed on  $X'$ . We remove the puncture neighbourhoods bounded by these horocycles. This results in an  $H$ -invariant complete hyperbolic metric  $d_{\mathbb{H}}$  on  $\overline{X - A}$  whose boundary components are horocycles of length  $l$ . If there are  $k$  curves in  $A$ , the ways of identifying the boundary components of  $(\overline{X - A}, d_{\mathbb{H}})$  in order to obtain a (marked) conformal structure on  $X$  are parametrised by points in an affine space  $\mathbb{R}^k$ : changing the  $k^{\text{th}}$  coordinate corresponds to a twist along the  $k^{\text{th}}$  boundary component. The group  $H$  admits an action on this parameter space  $\mathbb{R}^k$  by isometries (which are again compositions of translations and axes interchanges). The fixed point of this action gives an  $H$ -invariant conformal structure on  $X$ . By uniformisation this gives an  $H$ -invariant complete hyperbolic metric on  $X$ .  $\square$

## 5 Fixed clique in the disc graph

In this section, we prove [Metatheorem A\(1\)](#) in the case of the disc graph. We denote by  $U_g$  a handlebody of genus  $g$ . A (disconnected) handlebody  $U$  is a disjoint union of various  $U_g$ . The boundary  $\partial U$  is a closed surface that may be disconnected. An essential disc  $D$  in  $U$  is a disc properly embedded in  $U$ , such that  $\partial D$  is an essential simple closed curve on  $\partial U$ . We say that an essential simple closed curve  $d$  on  $\partial U$  is *discbounding* if there is an essential disc  $D$  with  $\partial D = d$ . Two essential discs  $D, D'$  are properly homotopic if and only if their boundary curves  $\partial D$  and  $\partial D'$  are homotopic.

By  $\mathcal{D}(U)$  we denote the *disc graph* of  $U$ . The vertex set  $\mathcal{D}^0(U)$  is the set of homotopy classes of discbounding curves on  $\partial U$ . Two such vertices are connected by an edge if the corresponding curves are disjoint (up to homotopy).

The *handlebody group*  $\text{Map}(U)$  is the mapping class group of  $U$ , ie the group of orientation-preserving homeomorphisms of  $U$  up to isotopy. It is well known that  $\text{Map}(U)$  can be identified with a subgroup of  $\text{Map}(\partial U)$  by restricting homeomorphisms of  $U$  to the boundary.

The main theorem of this section is the following.

**Theorem 5.1** *Let  $U$  be a (possibly disconnected) handlebody, each component of which has genus at least 2. Let  $H$  be a finite subgroup of  $\text{Map}(U)$ . Then  $H$  fixes a clique in the disc graph  $\mathcal{D}(U)$ .*

As an immediate consequence, we obtain the following.

**Corollary 5.2** *Every finite order element of the handlebody group is reducible.*

Corollary 5.2 also follows from the Lefschetz fixed point theorem, since the disc complex is contractible [23, Theorem 5.3].

## 5.1 Disc surgery

In this section we describe the surgery procedure that will be used to define dismantling projections on the disc graph. This surgery procedure was used in [23] to prove contractibility of the disc complex.

Let  $D$  and  $D'$  be two transverse essential discs in  $U$ . We say that  $D$  and  $D'$  are in *minimal position* if the boundary curves  $d = \partial D$  and  $d' = \partial D'$  are in minimal position, and  $D$  and  $D'$  intersect only along arcs.

For any pair of discbounding curves  $d$  and  $d'$  in minimal position, it is always possible to find discs  $D$  and  $D'$  in minimal position with  $\partial D = d$ ,  $\partial D' = d'$ . However, at this point we want to warn the reader that the minimal position of discs is not unique: in particular, the homotopy classes of  $d$  and  $d'$  do not determine which intersection points of  $d$  and  $d'$  are connected by an intersection arc of  $D \cap D'$ .

Now let  $D$  and  $D'$  be two essential discs in minimal position, and let  $d$  and  $d'$  denote their boundary curves. Assume that  $d$  and  $d'$  intersect. We then say that a subarc  $a$  of  $d$  is *outermost in  $D$  for  $D'$* , if  $a$  bounds a disc in  $D$  together with a component of  $D \cap D'$ , and the interior of  $a$  is disjoint from  $D'$ . The endpoints of  $a$  decompose  $d'$  into two subarcs  $a'_+$  and  $a'_-$ . The unions  $d'_+ = a \cup a'_+$  and  $d'_- = a \cup a'_-$  are simple closed curves on  $\partial U$ , both of which are discbounding by construction. See Hamenstädt and Hensel [9, Section 5] or Masur [22] for a detailed description of this surgery procedure. Since  $d$  and  $d'$  are in minimal position, both  $d'_+$  and  $d'_-$  are essential. We say that the discbounding curves  $d'_+$  and  $d'_-$  are obtained by *outermost surgery of  $d'$  in the direction of  $d$  determined by  $a$* .

Note that the homotopy classes  $\delta'_+$  of  $d'_+$  and  $\delta'_-$  of  $d'_-$  depend only on the homotopy classes  $\delta$  of  $d$  and  $\delta'$  of  $d'$ , and the choice of an outermost subarc. We call the pair  $\{\delta'_+, \delta'_-\}$  an *outermost surgery pair of  $\delta'$  in the direction of  $\delta$* . Note that there are only finitely many outermost surgery pairs for any choice of discbounding homotopy classes  $\delta$  and  $\delta'$ .

If  $\delta \neq \delta'$  have disjoint representatives, then we say that the only *outermost surgery pair of  $\delta'$  in the direction of  $\delta$*  is  $\{\delta, \delta\}$ , interpreted as a pair both of whose elements are equal to  $\delta$ . For homotopy classes  $\delta, \delta' \in \mathcal{D}^0(U)$  of discbounding curves, we define  $\Pi_\delta(\delta')$  to be the set of all outermost surgery pairs of  $\delta'$  in the direction of  $\delta$ .

The next lemma shows that  $\Pi_\sigma$  satisfies the axioms of a  $\sigma$ -projection for each  $\sigma \in \mathcal{D}^0(U)$ . This lemma essentially follows from the proof of [23, Theorem 5.3].

**Lemma 5.3** *Let  $\sigma \in \mathcal{D}^0(U)$  be a discbounding curve on  $\partial U$ .*

- (i) *Let  $R \subset \mathcal{D}^0(U)$  be a finite set of discbounding curves with  $R \setminus \{\sigma\} \neq \emptyset$ . Then there is a discbounding curve  $\rho \in R \setminus \{\sigma\}$  with the following property: there is an outermost surgery pair  $\{\rho_+, \rho_-\}$  of  $\rho$  in the direction of  $\sigma$  such that each discbounding curve  $\rho' \in R$  that is disjoint from  $\rho$  is also disjoint from  $\rho_+$  and  $\rho_-$ .*
- (ii) *Every sequence  $(\rho_i)$  of discbounding curves in  $\mathcal{D}^0(U)$  such that  $\rho_{i+1}$  is contained in an outermost surgery pair of  $\rho_i$  in the direction of  $\sigma$  terminates, after finitely many steps, with the discbounding curve  $\sigma$ .*

Again, we will use hyperbolic geometry to choose preferred representatives in the homotopy class of discbounding curves. To this end we fix a hyperbolic metric on  $\partial U$ .

**Proof** (i) Note that if each element of  $R$  can be realised disjointly from  $\sigma$ , then the assertion follows trivially.

Otherwise, let  $s$  be the geodesic representative of  $\sigma$  and let  $r^1$  be the geodesic representative of an arbitrary element in  $R$  intersecting  $s$ . Choose an embedded disc  $D^1$  in  $U$  bounded by  $r^1$  and an embedded disc  $D$  bounded by  $s$  that are in minimal position. Let  $a \subset \partial D$  be an outermost subarc in  $D$  for  $D^1$ . Let  $N$  be the set of geodesic representatives of all the elements in  $R$  that are disjoint from  $r^1$ . For each  $r' \in N$  we may choose a disc  $D(r')$  bounded by  $r'$  that is disjoint from  $D^1$  and in minimal position with respect to  $D$ . Note that this means that outermost subarcs in  $D$  for the discs  $D(r')$  are either disjoint from  $a$ , contain  $a$ , or are contained in  $a$ . We distinguish two cases.

If all outermost subarcs in  $D$  for the discs  $D(r')$ ,  $r' \in N$  are disjoint from  $a$  or contain  $a$ , then both discbounding curves obtained by the outermost surgery pair determined by  $a$  are disjoint from the curves in  $N$ , and therefore the homotopy class  $\rho^1$  of  $r^1$  satisfies the condition in assertion (i).

On the other hand, assume that there is a disc  $D^2 = D(r^2)$  bounded by  $r^2 \in N$  that has an outermost subarc that is contained in  $a$ . In this case, we replace  $r^1$  by  $r^2$ , and inductively apply the same argument again. Since the geodesic representatives of all elements in  $R$  intersect in finitely many points, this process stops after finitely many steps with the first case with  $\rho^k$  satisfying the condition in assertion (i).

(ii) The proof of this is identical to the proof of Lemma 3.2(ii). Namely, each outermost surgery strictly decreases the geometric intersection number with  $\sigma$ .  $\square$

The fact that homeomorphisms of  $U$  map outermost subarcs to outermost subarcs immediately implies the following.

**Lemma 5.4** *For every  $h \in \text{Map}(U)$ , we have  $h\Pi_\sigma(\rho) = \Pi_{h\sigma}(h\rho)$  for all discbounding curves  $\sigma \neq \rho \in \mathcal{D}^0(U)$ .*

## 5.2 Finite hull for discs

Let  $\delta_1, \dots, \delta_k \in \mathcal{D}^0(U)$  be a finite set of discbounding curves. For a homotopy class  $\alpha$  of an essential simple closed curve on  $\partial U$ , we denote by  $l_{\partial U}(\alpha)$  the length of the geodesic representative of  $\alpha$  on  $\partial U$ . Put

$$L = \max_i l_{\partial U}(\delta_i).$$

Let  $\mathcal{H} = \mathcal{H}(\delta_1, \dots, \delta_k)$  be the set of discbounding curves  $\delta$  that satisfy  $l_{\partial U}(\delta) \leq 2L$ . Note that  $\mathcal{H}(\delta_1, \dots, \delta_k)$  is a finite set of curves that contains  $\delta_1, \dots, \delta_k$ .

The following lemma shows that  $\mathcal{H}$  is  $\Pi_\sigma$ -convex for each  $\sigma = \delta_i, i = 1, \dots, k$ .

**Lemma 5.5** *Let  $\delta_1, \dots, \delta_k \in \mathcal{D}^0(U)$  be a finite set of discbounding curves. Put  $\delta = \delta_i$  for some  $i = 1, \dots, k$ , and let  $\delta' \in \mathcal{H} = \mathcal{H}(\delta_1, \dots, \delta_k)$  be arbitrary. Then each outermost surgery pair of  $\delta'$  in the direction of  $\delta$  contains at least one element of  $\mathcal{H}$ .*

**Proof** Denote by  $d$  the geodesic representative of  $\delta$ , and by  $d'$  the geodesic representative of  $\delta'$ . We can assume that  $d$  and  $d'$  intersect. Let  $a \subset d$  be an outermost subarc. By definition of  $L$ , the subarc  $a$  has length at most  $L$ .

The endpoints of  $a$  decompose  $d'$  into two subarcs  $a'_+$  and  $a'_-$ . Since  $d'$  has length at most  $2L$ , at least one of these subarcs has length less or equal to  $L$ , say  $a'_+$ . Then  $d'_+ = a \cup a'_+$  has length at most  $2L$ . In particular, the homotopy class of  $d'_+$  is contained in  $\mathcal{H}$ , as required.  $\square$

As a consequence of Lemmas 5.3, 5.5 and 5.4, we obtain [Theorem 5.1](#) from [Theorem 1.1](#) under hypothesis (ii) in the same way that we obtained [Theorem 3.1](#).

## 6 Nielsen realisation for handlebodies

### 6.1 Fixed simple disc system

Let  $\{d_1, \dots, d_k\}$  be a finite set of discbounding curves that are pairwise disjoint. We say that  $\{d_1, \dots, d_k\}$  is a *simple disc system* if each complementary component

of  $d_1 \cup \dots \cup d_k$  on  $\partial U$  is a *bordered 2–sphere*, ie a 2–sphere minus open discs. Equivalently, the complementary components of disjoint discs bounded by  $d_1, \dots, d_k$  in  $U$  are simply connected. A clique  $\Delta \subset \mathcal{D}^0(U)$  is called *simple* if some (hence any) set of disjoint representatives of elements in  $\Delta$  is a simple disc system.

In this section we use the results obtained in [Section 5](#) to show the following.

**Theorem 6.1** *Let  $U$  be a connected handlebody of genus  $g \geq 2$ . Let  $H$  be a finite subgroup of  $\text{Map}(U)$ . Then  $H$  fixes a simple clique in the disc graph  $\mathcal{D}^0(U)$ .*

Before we give a proof, we note the following corollary.

**Corollary 6.2** *Let  $U$  be a connected handlebody of genus  $g \geq 2$ . A finite order mapping class  $h \in \text{Map}(\partial U)$  is conjugate into the handlebody group  $\text{Map}(U)$  if and only if  $h$  fixes a set of homotopy classes of disjoint essential simple closed curves on  $\partial U$ , all of whose complementary components are bordered 2–spheres.*

**Proof** If  $h$  is contained in a conjugate of the handlebody group, then [Theorem 6.1](#) yields the desired set of curves. Now let  $h$  be a mapping class fixing a set of curves  $\{\alpha_1, \dots, \alpha_k\}$  as required. We may then choose a mapping class  $g \in \text{Map}(\partial U)$  such that the  $g(\alpha_i)$  are discbounding in  $U$ . This element  $g$  then conjugates  $h$  into the handlebody group of  $U$ .  $\square$

**Proof of Theorem 6.1** By [Theorem 5.1](#) there is a clique  $\Delta = \{\delta_1, \dots, \delta_n\}$  in the disc graph  $\mathcal{D}(U)$ , invariant under  $H$ . We will argue that if  $\Delta$  is a maximal  $H$ –invariant clique, then it is simple.

As a first step, using [Theorem 1.3](#) with hypothesis (B), we find that there is a hyperbolic metric on  $X = \partial U$  such that  $H$  acts as a group of isometries on  $X$ . Denote by  $d_i$  the geodesic representative of  $\delta_i$ . Then  $H$  acts on  $X$ , preserving the set  $d_1 \cup \dots \cup d_n$ . Let  $X_0$  be the union of all the components of  $X - (d_1 \cup \dots \cup d_n)$  that are not bordered 2–spheres. Denote by  $\bar{X}_0$  the completion (with respect to the path metric) of  $X_0$ . We will prove that  $\bar{X}_0$  is empty, which implies that  $\Delta$  is simple.

Suppose on the contrary that  $\bar{X}_0$  is nonempty. In this case, let  $X'$  be the surface obtained from  $\bar{X}_0$  by gluing a disc to each boundary component. Since  $\bar{X}_0$  embeds naturally into  $X'$ , we can identify  $\bar{X}_0$  with a subsurface of  $X'$ . Since  $H$  acts as a group of isometries on  $\bar{X}_0$ , it maps into the mapping class group of  $X'$ . Furthermore,  $X'$  is, in a natural way, the boundary of a (possibly disconnected) handlebody  $U'$  (cut  $U$  along discs bounded by  $d_i$ ), and so  $H$  maps into the handlebody group of  $U'$ .

If  $U'$  has genus 1 components, then we consider the  $H$ -invariant clique  $\Delta' \subset \mathcal{D}^0(U')$  of unique discbounding curves in all of these components. Otherwise the group  $H$  fixes a clique  $\Delta' \subset \mathcal{D}^0(U')$  by [Theorem 5.1](#). Denote  $\Delta' = \{\delta'_1, \dots, \delta'_k\}$ .

For a homotopy class of an essential simple closed curve  $\alpha'$  on  $X'$ , let  $\mathcal{F}(\alpha')$  be the set of all homotopy classes of simple closed curves  $\alpha$  on  $\bar{X}_0$  that are homotopic to  $\alpha'$  as a curve on  $X'$ . Note that each such  $\alpha$  is essential. Furthermore, if  $\alpha'$  is discbounding in  $U'$ , then each element of  $\mathcal{F}(\alpha')$  is discbounding in  $U$ . We put  $\mathcal{F}(\Delta') = \mathcal{F}(\delta'_1) \cup \dots \cup \mathcal{F}(\delta'_k)$ .

Set

$$L = \min\{l_{\bar{X}_0}(\alpha) \mid \alpha \in \mathcal{F}(\Delta')\} \quad \text{and} \quad \Delta^* = \{\alpha \in \mathcal{F}(\Delta') \mid l_{\bar{X}_0}(\alpha) = L\}.$$

The group  $H$ , seen as a subgroup of the mapping class group of  $\bar{X}_0$ , preserves  $\Delta^*$ . We claim that any two elements of  $\Delta^*$  correspond to disjoint curves. This claim implies the theorem, since  $\Delta^*$  can be then interpreted as a clique in  $\mathcal{D}(U)$ . Thus we can extend the initial clique  $\Delta$  by the clique  $\Delta^*$ , contradicting maximality.

To prove the claim, let  $\alpha_1, \alpha_2$  be two elements of  $\Delta^*$ , and let  $a_1$  and  $a_2$  be their geodesic representatives on  $\bar{X}_0$ . Suppose that  $a_1$  and  $a_2$  intersect. Since  $a_1$  and  $a_2$  are homotopic to disjoint curves after gluing discs to the boundary components of  $\bar{X}_0$ , there are subarcs  $c_i \subset a_i$  such that  $c_1 \cup c_2$  bounds a bordered 2-sphere together with boundary components of  $\bar{X}_0$  (see [Figure 2](#)).

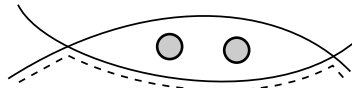

Figure 2: Intersecting preimages are not shortest

Suppose that the length of the geodesic arc  $c_1$  is smaller (or equal to) the length of  $c_2$ . In this case, the curve  $\hat{a}$  obtained from  $a_2$  by replacing  $c_2$  with  $c_1$  is a broken geodesic that is homotopic to  $a_2$  on  $X'$ . Hence its homotopy class lies in  $\mathcal{F}(\Delta')$ . However, the length of the broken geodesic  $\hat{a}$  is, by construction, at most  $L$ , and hence its geodesic representative has length strictly less than  $L$ . This contradicts the choice of  $L$ , and therefore proves the claim. □

## 6.2 Fixed Schottky group

In this section we obtain a Nielsen realisation theorem for the handlebody group.

**Proof of Theorem 1.4** Let  $X = \partial U$ . By Theorem 6.1 there is a simple clique  $\Delta = \{\delta_1, \dots, \delta_n\}$  that is fixed by the group  $H$ . Let  $\{d_1, \dots, d_n\}$  be a set of disjoint representatives of the  $\delta_i$  and denote by  $X_1, \dots, X_k$  the complementary components of the  $d_i$  on  $X$ . For each such bordered 2–sphere  $X_i$ , denote by  $X'_i$  the punctured sphere obtained by replacing each boundary component of  $X_i$  by a puncture. Let  $X'$  be the disjoint union of these punctured spheres. Note that  $H$  acts on  $X'$  as a group of mapping classes. By Theorem 1.3 with hypothesis (A), there is a complete hyperbolic metric on  $X'$  such that  $H$  acts as a group of isometries.

The hyperbolic metric on  $X'_i$  can be interpreted as a conformal structure on a punctured sphere. By the uniformisation theorem, it is biholomorphic to the complement of a finite number of points  $p_i^1, \dots, p_i^{k_i}$  on a copy  $\widehat{C}_i$  of the Riemann sphere, with  $k_i \geq 3$ . The group  $H$  acts on the union  $X'$  of  $X'_i \subset \widehat{C}_i$  by Möbius transformations, since every conformal automorphism of  $\widehat{C}$  is a Möbius transformation.

Consider now a round disc  $B_i^j$  centred at one of the points  $p_i^j$  that is disjoint from all other such points. Suppose that  $h \in H$  fixes the point  $p_i^j$ . Since  $h$  is a Möbius transformation of finite order that fixes  $p_i^j$  and permutes  $k_i - 1 \geq 2$  other points  $p_i^{j'}$ , it is in fact a rotation about  $p_i^j$  and thus preserves  $B_i^j$ . Therefore we may choose a collection of disjoint discs  $B_i^j$ , such that  $B_i^j$  is centred at  $p_i^j$ , that is invariant under the action of  $H$ .

We interpret each  $\widehat{C}_i$  as the boundary of a copy  $\mathbb{H}_i^3$  of the hyperbolic 3–space. Let  $\mathcal{H}(B_i^j)$  be the halfspace in  $\mathbb{H}_i^3$  that is the convex hull of  $B_i^j$ , and let  $M_i$  be the complement of the interiors of all  $\mathcal{H}(B_i^j)$  in  $\mathbb{H}_i^3$ . Note that the boundary components of the manifolds  $M_i$  correspond to punctures of  $X'$ . The punctures of  $X'$  have a natural pairing, since each marked point of  $X'$  corresponds to a side of a disc in the simple disc system  $\{d_1, \dots, d_n\}$ . We now glue the manifolds  $M_i$  along their boundaries according to this pairing, such that the closest projections of the points  $p_i^j$  to the boundary planes  $\partial\mathcal{H}(B_i^j)$  agree. By arguing as in the proof of Theorem 1.3 under hypothesis (B), we can choose the twist parameters consistently such that  $H$  acts on the resulting hyperbolic manifold  $M$  as a group of isometries. □

## 7 Fixed clique in the sphere graph

Let  $U$  be a (possibly disconnected) handlebody and let  $W = W(U)$  be the 3–manifold obtained by doubling  $U$  along its boundary. The manifold  $W$  is homeomorphic to the disjoint union of iterated connected sums of  $S^1 \times S^2$ . A connected component of  $W$  has rank  $n$  if its fundamental group has rank  $n$ . By  $\text{Map}(W)$  we denote the mapping



class group of  $W$ , ie the group of orientation-preserving homeomorphisms of  $W$  up to isotopy.

A 2–sphere embedded in  $W$  is called *essential* if it does not bound a ball. Unless stated otherwise, we assume that spheres are embedded and essential 2–spheres.

We define the *sphere graph*  $\mathcal{S}(W)$  of  $W$ . Its vertex set  $\mathcal{S}^0(W)$  is the set of isotopy classes of spheres in  $W$ . Two vertices of  $\mathcal{S}(W)$  are connected by an edge if the corresponding spheres can be realised disjointly.

The fundamental group of a doubled connected handlebody  $W_n = W(U_n)$  of rank  $n$  is the free group on  $n$  generators. Hence, the mapping class group  $\text{Map}(W_n)$  of  $W_n$  admits a homomorphism to  $\text{Out}(F_n)$ . By a theorem of Laudenbach [21, Theorem 4.3, Remark 1], this map is surjective and has finite kernel generated by Dehn twists along spheres. Therefore the elements of the kernel act trivially on isotopy classes of spheres. As a consequence,  $\text{Out}(F_n)$  acts as a group of automorphisms on  $\mathcal{S}(W_n)$  (see [14] for a thorough treatment of this graph).

We can now state the main theorem of this section.

**Theorem 7.1** *Let  $W$  be a (possibly disconnected) doubled handlebody, each component of which has rank at least 2. Let  $H$  be a finite subgroup of  $\text{Map}(W)$ . Then  $H$  fixes a clique in the sphere graph  $\mathcal{S}(W)$ .*

By the discussion in the previous paragraph, Theorem 7.1 immediately implies that if  $H$  is a finite subgroup of  $\text{Out}(F_n)$ , then it fixes a clique in  $\mathcal{S}(W_n)$ .

The strategy to prove Theorem 7.1 will be analogous to the strategy employed in Sections 3 and 5. In the cases of the arc and disc graph, we used hyperbolic metrics on surfaces to select preferred representatives of arcs and discbounding curves. In the manifold  $W$  we do not have such geometric tools. In the following section we recall and extend the notion of *normal position* from [14], which is a topological tool allowing us to put pairs of spheres in a preferred position with good properties.

## 7.1 Normal position

A *sphere system*  $S_0$  in  $W$  is a collection of disjoint spheres in  $W$ , no two of which are isotopic. Note that two sphere systems are isotopic if and only if they are homotopic, by a theorem of Laudenbach (see [21]). A sphere system is *maximal* if it is not properly contained in another sphere system.

For a sphere system  $S_0$  in  $W$ , we call the (path-metric) closures of the connected components of  $W - S_0$  the *complementary components of  $S_0$*  (in  $W$ ). A sphere system

is maximal if and only if each of its complementary components in  $W$  is homeomorphic to the 3–sphere minus three open balls. A *dual graph*  $\Gamma$  is associated to a sphere system  $S_0$  in the following way. The vertex set of  $\Gamma$  is the set of complementary components of  $S_0$ . Each sphere  $s_0 \in S_0$  defines an edge in  $\Gamma$ , connecting the vertices corresponding to the two (possibly coinciding) complementary components of  $S_0$  adjacent to  $s_0$ . Note that the graph  $\Gamma$  might not be simple. In particular, it might happen that a complementary component of  $S_0$  is adjacent along two distinct boundary components to the same sphere in  $S_0$ , and then  $\Gamma$  contains a loop.

Let  $s$  be a sphere which is transverse to  $S_0$ . The intersection of  $s$  with a complementary component of  $S_0$  is a disjoint union of bordered 2–spheres. We call these components *sphere pieces of  $s$  with respect to  $S_0$* .

A sphere  $s$  is in *normal position* with respect to a maximal sphere system  $S_0$  (see [14]) if  $s$  is transverse to  $S_0$  and each sphere piece  $P$  of  $s$  satisfies the following two conditions:

- (1) The piece  $P$  meets each boundary component of a complementary component of  $S_0$  in at most one circle.
- (2) The piece  $P$  is not a disc which is homotopic into  $S_0$  relative to its boundary.

We say that a sphere piece  $P$  is *problematic of type (1) or (2)*, if it violates conditions (1) or (2) above. In that case we say that it is *problematic with respect to  $s_0 \in S_0$*  if the boundary component of the complementary component on which  $P$  shows the excluded behaviour corresponds to  $s_0$ . We say that a sphere system  $S$  is in *normal position* with respect to  $S_0$  if each sphere  $s \in S$  is in normal position with respect to  $S_0$ .

Normal position of spheres is unique in the following sense: suppose that  $s, s'$  are isotopic spheres that are in normal position with respect to some maximal sphere system  $S_0$ . Then by [14, Proposition 1.2] there is a homotopy between  $s$  and  $s'$  that restricts to an isotopy on  $S_0$  (Hatcher considers only the case of connected  $W$ , but the disconnected case follows immediately by considering the connected components individually). We say that sphere pieces of  $s$  and  $s'$  are *corresponding*, if they are mapped to each other by such a homotopy. Correspondence identifies the sphere pieces of  $s$  bijectively with the sphere pieces of  $s'$ .

Next, we characterise normal position using lifts to the universal cover  $\widetilde{W}$  of  $W$ . Since  $W$  is allowed to be disconnected, we define  $\widetilde{W}$  to be the disjoint union of the universal covers of the components of  $W$ . Note that since spheres are simply connected, every sphere in  $W$  lifts homeomorphically to  $\widetilde{W}$ . The definitions of sphere systems, complementary components, sphere pieces and normal position extend verbatim to spheres in  $\widetilde{W}$ .

**Lemma 7.2** *Let  $S_0$  be a maximal sphere system in  $W$  and let  $s$  be a sphere in  $W$ . Denote by  $\tilde{S}_0$  the full preimage of  $S_0$  in  $\tilde{W}$ . Then the following are equivalent:*

- (i) *The sphere  $s$  is in normal position with respect to  $S_0$ .*
- (ii) *One (and hence any) lift  $\tilde{s}$  of  $s$  is in normal position with respect to  $\tilde{S}_0$ .*
- (iii) (1) *One (and hence any) lift  $\tilde{s}$  of  $s$  intersects each component of  $\tilde{S}_0$  in at most one circle, and*  
 (2) *there is no disc in  $\tilde{s}$  homotopic relative to its boundary into  $\tilde{S}_0$ .*

**Proof** Assertion (i) is equivalent to (ii) since a piece  $\tilde{P}$  of  $\tilde{s}$  that is a lift of piece  $P$  of  $s$  is problematic if and only if  $P$  is problematic. It is clear that (iii) implies (ii). It remains to prove that assertion (ii) implies (iii).

For part (1), let  $\tilde{s}_0$  be a sphere of  $\tilde{S}_0$ . Suppose that  $\tilde{s}_0$  and  $\tilde{s}$  intersect in at least two circles  $\tilde{c}$  and  $\tilde{c}'$ . Let  $a \subset \tilde{s}$  be a path joining  $\tilde{c}$  and  $\tilde{c}'$ , and crossing the least number of complementary components of  $\tilde{S}_0$ . Since the graph dual to  $\tilde{S}_0$  in  $\tilde{W}$  is a forest, there is a complementary component  $\tilde{K}$  of  $\tilde{S}_0$  such that  $a$  intersects only one boundary component of  $\tilde{K}$ . Then a sphere piece of  $\tilde{s}$  in  $\tilde{K}$  is problematic of type (1).

For part (2), suppose there is a disc in  $\tilde{s}$  homotopic relative to its boundary into  $\tilde{S}_0$ . Then it contains a subdisc that is a piece of  $\tilde{s}$ , problematic of type (2). □

Motivated by Lemma 7.2, we say that two transverse spheres  $\tilde{s}$  and  $\tilde{s}'$  in  $\tilde{W}$  are in *normal position* if

- (1)  $\tilde{s}$  and  $\tilde{s}'$  intersect in at most one circle, and
- (2) none of the discs in  $\tilde{s} - \tilde{s}'$  is homotopic into  $\tilde{s}'$  relative to its boundary.

Note that this relation is symmetric with respect to  $\tilde{s}$  and  $\tilde{s}'$ .

We say that two spheres  $s, s'$  in  $W$  are in *normal position* if all of their lifts to  $\tilde{W}$  are in normal position. Note that given two spheres  $s, s'$ , we can change  $s$  by a homotopy to be in normal position with  $s'$ . Namely, extend  $s'$  to a maximal sphere system  $S'$ . Then [14, Proposition 1.1] implies that we can homotope  $s$  to be in normal position with respect to  $S'$ . By Lemma 7.2, the spheres  $s, s'$  are then in normal position as well. Similarly, given a sphere  $s'$  in  $W$ , we can homotope any sphere system  $S$  in  $W$  so that  $s$  and  $s'$  are in normal position for any  $s \in S$ .

We need the following uniqueness property of normal position for a pair of spheres.

**Lemma 7.3** *Let  $s_0$  be a sphere in  $W$ , and let  $s, s'$  be two isotopic spheres in  $W$  that are in normal position with respect to  $s_0$ . Then there is a homotopy between  $s$  and  $s'$  that restricts to an isotopy on  $s_0$ .*

**Proof** Extend  $s_0$  to a maximal sphere system  $S_0$ . We first claim that we can change  $s$  and  $s'$  to be in normal position with respect to  $S_0$  by a homotopy that restricts to the identity on  $s_0$ . We give the proof of the claim for  $s$ ; the proof for  $s'$  is identical.

Suppose that  $s$  is not in normal position with respect to  $S_0$ . Then there is a sphere piece  $P$  of  $s$  with respect to  $S_0$  that is problematic. Following the proof of [14, Proposition 1.1], we may modify  $s$  by a homotopy to remove this problematic piece. This homotopy moves  $s$  through  $s_0$  if and only if the sphere piece  $P$  is problematic with respect to  $s_0$ . If  $P$  were problematic of type (1), then a lift of  $s$  would intersect a lift of  $s_0$  in two circles. If  $P$  were problematic of type (2), then a lift of  $s$  would contain a disc that is homotopic into a lift of  $s_0$  relative to its boundary. Both of these cases are excluded by  $s$  and  $s_0$  being in normal position. Hence every problematic piece  $P$  of  $s$  with respect to  $S_0$  can be removed by a homotopy of  $s$  that does not move  $s$  through  $s_0$ . Furthermore, such homotopies keep  $s$  in normal position with respect to  $s_0$ . This shows the claim.

Now the assertion of the lemma follows from [14, Proposition 1.2], which states that there is a homotopy between  $s$  and  $s'$  that restricts to an isotopy on  $S_0$ . □

## 7.2 Sphere surgery

In this section we describe a surgery procedure for spheres. This surgery procedure was defined and used in [14] to show contractibility of the sphere complex.

Suppose that spheres  $s$  and  $s'$  in  $W$  intersect and are in normal position. We say that a disc  $D \subset s$  is *outermost in  $s$  for  $s'$*  if  $D \cap s' = \partial D$ .

Let  $D$  be an outermost disc in  $s$  for  $s'$ . Denote by  $D'_+$  and  $D'_-$  the two components of  $s' - \partial D$ . Then we say that the spheres  $s'_+ = D'_+ \cup D, s'_- = D'_- \cup D$  are obtained by *outermost surgery of  $s'$  in the direction of  $s$  determined by  $D$* . The normal position of  $s$  and  $s'$  implies that both  $s'_+$  and  $s'_-$  are essential spheres.

By Lemma 7.3, the notion of outermost discs is well-defined for isotopy classes of spheres. Hence the isotopy classes  $\sigma'_+, \sigma'_-$  of  $s'_+, s'_-$  depend only on the isotopy classes  $\sigma$  of  $s$  and  $\sigma'$  of  $s'$ . We call the pair  $\{\sigma'_+, \sigma'_-\}$  an *outermost surgery pair of  $\sigma'$  in the direction of  $\sigma$* .

If  $\sigma' \neq \sigma$  are disjoint, then the only *outermost surgery pair of  $\sigma'$  in the direction of  $\sigma$*  is  $\{\sigma, \sigma\}$ , interpreted as a pair both of whose elements are equal to  $\sigma$ . Let  $\Pi_\sigma(\sigma')$  be the set of all outermost surgery pairs of  $\sigma'$  in the direction of  $\sigma$ .

We next show that  $\Pi_\sigma$  satisfies the axioms of a  $\sigma$ -projection for all  $\sigma \in S^0(W)$ . The main technical result needed for this is given by the following lemma.

**Lemma 7.4** *Let  $S_0$  be a maximal sphere system in  $W$ . Suppose that  $r_1, \dots, r_k$  is a sequence of spheres in normal position with respect to  $S_0$ . Assume that for each  $1 \leq i \leq k - 1$ , the sphere  $r_{i+1}$  is disjoint from  $r_i$ , and that  $r_1$  is isotopic to  $r_k$ . Let  $c_i \subset r_i \cap S_0$  be a sequence of intersection circles bounding discs  $D_i \subset S_0$ . Suppose that  $D_{i+1} \subset D_i$  for each  $1 \leq i \leq k - 1$ . If  $c_1$  and  $c_k$  are boundaries of corresponding sphere pieces of  $r_1$  and  $r_k$ , then all  $r_i$  are in fact isotopic.*

**Proof** Suppose that the  $r_i$  are spheres satisfying the hypothesis of the lemma. Denote by  $K$  the complementary component of  $S_0$  that contains the corresponding sphere pieces  $P_1$  of  $r_1$  and  $P_k$  of  $r_k$ . For each  $1 < i < k$ , let  $P_i$  be the sphere piece of  $r_i$  contained in  $K$  and bounded by  $c_i$ . The complementary component  $K$  lifts into  $\widetilde{W}$  homeomorphically to a complementary component  $\widetilde{K}$  of the full preimage  $\widetilde{S}_0$  of  $S_0$ . Let  $\widetilde{P}_i$  and  $\widetilde{D}_i$  be the lifts of  $P_i$  and  $D_i$  into  $\widetilde{K}$ . Let  $\widetilde{r}_i$  be the lift of  $r_i$  containing  $\widetilde{P}_i$ .

Each sphere  $\widetilde{r}_i$  separates the universal cover  $\widetilde{W}$  into two connected components. We call the component that contains  $\widetilde{D}_i$  the *outside* of  $\widetilde{r}_i$ . Since  $r_i$  and  $r_{i+1}$  are disjoint, the lift  $\widetilde{r}_{i+1}$  is completely contained on the outside of  $\widetilde{r}_i$  for each  $1 \leq i \leq k - 1$ . In particular,  $\widetilde{r}_1$  and  $\widetilde{r}_k$  are disjoint.

By the definition of correspondence, there is a homotopy of  $r_1$  to  $r_k$  that restricts to an isotopy on  $S_0$  and maps  $P_1$  to  $P_k$ . Lifting this homotopy, we see that  $\widetilde{r}_1$  is homotopic to  $\widetilde{r}_k$ . Therefore,  $\widetilde{r}_1$  and  $\widetilde{r}_k$  bound a product region that contains all the  $\widetilde{r}_i$ . In particular, all the  $\widetilde{r}_i$  are homotopic, as desired.  $\square$

**Lemma 7.5** *Let  $\sigma \in S^0(W)$  be a sphere in  $W$ .*

- (i) *Let  $R \subset S^0(W)$  be a finite set of spheres with  $R \setminus \{\sigma\} \neq \emptyset$ . Then there is a sphere  $\rho \in R \setminus \{\sigma\}$  with the following property: there is an outermost surgery pair  $\{\rho_+, \rho_-\}$  of  $\rho$  in the direction of  $\sigma$  such that each sphere  $\rho' \in R$  that is disjoint from  $\rho$  is also disjoint from  $\rho_+$  and  $\rho_-$ .*
- (ii) *Every sequence  $(\rho_i)$  of spheres such that  $\rho_{i+1}$  is obtained from  $\rho_i$  by an outermost surgery in the direction of  $\sigma$  terminates, after finitely many steps, with  $\sigma$ .*

**Proof** (i) We can assume that not all the spheres in  $R$  are disjoint from  $\sigma$ , since otherwise the assertion follows trivially. Let  $s$  be a representative of  $\sigma$  and let  $S$  be an extension of  $s$  to a maximal sphere system. Let  $r^1$  be a representative of an arbitrary element  $\rho^1 \in R$  intersecting  $s$  in normal position with respect to  $S$ . Let  $D \subset s$  be an outermost disc for  $r^1$  and let  $N$  be the set of representatives of the spheres in  $R \setminus \{\rho^1\}$  that are disjoint from  $r^1$ .

We may assume that each  $r' \in N$  is in normal position with respect to  $S$ . Note that this means that outermost discs in  $s$  for the spheres  $r'$  are either disjoint from  $D$ , contain  $D$ , or are contained in  $D$ . We distinguish two cases.

If all outermost discs in  $s$  for all  $r' \in N$  are disjoint from  $D$  or contain  $D$ , then both spheres obtained by outermost surgery determined by  $D$  are disjoint from the spheres in  $N$ , and therefore  $r^1$  satisfies the condition required in (i).

On the other hand, assume that there is a sphere  $r^2 \in N$  for which an outermost disc is contained in  $D$ . In this case, we replace  $r^1$  by  $r^2$ , and inductively apply the same argument again. By Lemma 7.4, this process terminates, after finitely many steps, with the first case.

(ii) The proof of this part is similar to the proof of Lemma 3.2(ii). Namely, suppose that  $s$  and  $s'$  are two spheres in normal position that intersect in  $k$  circles. Then both spheres obtained by an outermost surgery of  $s'$  in the direction of  $s$  intersect  $s$  in at most  $k - 1$  circles. Putting spheres in normal position decreases the number of intersection circles (see the proof of [14, Proposition 1.1]). Thus an induction on this value proves the assertion. □

The fact that homeomorphisms of  $W$  map outermost discs to outermost discs immediately implies the following.

**Lemma 7.6** *For every  $h \in \text{Map}(W)$ , we have  $h\Pi_\sigma(\rho) = \Pi_{h\sigma}(h\rho)$  for all spheres  $\sigma \neq \rho$  in  $\mathcal{S}^0(W)$ .*

**Remark 7.7** Let  $\sigma$  be the isotopy class of a sphere in  $W$ . In Hamenstädt and Hensel [10] it is shown that the stabiliser of  $\sigma$  in  $\text{Map}(W)$  is an undistorted subgroup of  $\text{Map}(W)$ . Using the techniques developed in this section, the proof in [10] can be improved to show that the stabiliser of  $\sigma$  in  $\text{Map}(W)$  is in fact a coarse Lipschitz retract of  $\text{Map}(W)$ .

### 7.3 Finite hull for spheres

For this section, we fix a maximal sphere system  $S_0$  in  $W$ . Let  $\tilde{S}_0$  be the full preimage of  $S_0$  in  $\tilde{W}$ . We say that a surface in  $\tilde{W}$  has *width  $w$  with respect to  $\tilde{S}_0$*  if it crosses  $w$  complementary components of  $\tilde{S}_0$  in  $\tilde{W}$ . We say that a sphere  $s$  in  $W$  has *width  $w$  with respect to  $S_0$*  if one (hence any) lift of  $s$  to  $\tilde{W}$  has width  $w$ . A sphere  $\sigma \in \mathcal{S}^0(W)$  has *width  $w$*  if its representative  $s$  in normal position with respect to  $S_0$  has width  $w$ . In other words,  $s$  has  $w$  sphere pieces. This does not depend on the choice of  $s$ . Analogously, we define the width for the isotopy classes of spheres in  $\tilde{W}$ . In fact, the width of the class does not exceed the width of a representative.

**Lemma 7.8** *If  $\tilde{s}$  is a sphere in  $\tilde{W}$  of width  $w$ , and  $\tilde{s}'$  is an isotopic sphere in normal position with respect to  $\tilde{S}_0$ , then  $\tilde{s}'$  has width at most  $w$ .*

**Proof** Following the proof of [14, Proposition 1.1] we can homotope  $\tilde{s}$  to a sphere  $\tilde{s}'$  in normal position by successively removing problematic sphere pieces. In each such step, one slides the problematic piece through a sphere  $\tilde{s}_0 \in \tilde{S}_0$ . Such a homotopy does not increase the width, since the side of  $\tilde{s}_0$  that we push  $\tilde{s}$  towards already contains a piece of  $\tilde{s}$ . □

We are now able to describe the finite hull construction for the sphere graph. Let  $\sigma_1, \dots, \sigma_k \in S^0(W)$  be a collection of spheres with representatives  $s_1, \dots, s_k$ . Let  $w$  be the maximal width of any  $\sigma_i$  with respect to  $S_0$ . Let  $\mathcal{H} = \mathcal{H}(\sigma_1, \dots, \sigma_k)$  be the set of isotopy classes of spheres with width at most  $2w$  with respect to  $S_0$ . By construction, the set  $\mathcal{H}$  is finite and contains all the  $\sigma_i$ . The following lemma shows that  $\mathcal{H}$  is  $\Pi_\sigma$ -convex for all  $\sigma = \sigma_i$ .

**Lemma 7.9** *Let  $\sigma_1, \dots, \sigma_k \in S^0(W)$  be a finite set of spheres. Put  $\sigma = \sigma_i$ , and let  $\rho \in \mathcal{H} = \mathcal{H}(\sigma_1, \dots, \sigma_k)$  be arbitrary. Then each outermost surgery pair of  $\rho$  in the direction of  $\sigma$  contains at least one element of  $\mathcal{H}$ .*

**Proof** Let  $s, r$  be representatives of  $\sigma, \rho$  that are in normal position with respect to  $S_0$ . We can assume that  $s$  and  $r$  intersect. Let  $s_r$  be a representative of  $\sigma$  that is in normal position with respect to  $r$ . Let  $r_+, r_-$  be obtained by outermost surgery of  $r$  in the direction of  $s_r$  determined by an outermost disc  $D \subset s_r$ .

Let  $\tilde{r}$  be a lift of  $r$  to  $\tilde{W}$ , and let  $\tilde{s}_r$  be the lift of  $s_r$  that intersects  $\tilde{r}$  in the lift of  $\partial D$ . Denote by  $\tilde{s}$  the lift of  $s$  that is isotopic to  $\tilde{s}_r$ .

We may homotope  $\tilde{s}$  to be in normal position with respect to  $\tilde{r}$  without increasing its width. Namely, let  $\tilde{W}(\tilde{s})$  be the union of all the complementary components of  $\tilde{S}_0$  crossed by  $\tilde{s}$ . The manifold  $\tilde{W}(\tilde{s})$  is homeomorphic to a bordered 3-sphere (ie, a 3-sphere minus a finite disjoint union of open balls). Extend  $\tilde{s}$  to a maximal sphere system  $\tilde{S}$  in  $\tilde{W}(\tilde{s})$ . Since  $r$  is in normal position with respect to  $S_0$ , the lift  $\tilde{r}$  of  $r$  is in normal position with respect to  $\partial\tilde{W}(\tilde{s})$ . Therefore, we may homotope  $\tilde{S}$  within  $\tilde{W}(\tilde{s})$  as in the proof of [14, Proposition 1.1] so that  $\tilde{s}$  and  $\tilde{r}$  intersect in a single circle  $\tilde{c}$ . The circle  $\tilde{c}$  cuts  $\tilde{r}$  into two discs  $\tilde{D}_+, \tilde{D}_-$ . The normal position of  $\tilde{r}$  and  $\tilde{s}$  is determined by their isotopy classes, by Lemma 7.3. Therefore, there is a disc  $\tilde{D} \subset \tilde{s}$  bounded by  $\tilde{c}$  such that the spheres  $\tilde{r}_+ = \tilde{D}_+ \cup \tilde{D}$ ,  $\tilde{r}_- = \tilde{D}_- \cup \tilde{D}$  are isotopic to lifts of  $r_+$  and  $r_-$ .

Since  $\tilde{r}$  is in normal position with respect to  $\tilde{S}_0$ , each component of  $\tilde{r} - \tilde{W}(\tilde{s})$  belongs to exactly one of the discs  $\tilde{D}_+, \tilde{D}_-$ . Since  $\tilde{r}$  has width at most  $2w$ , without loss

of generality we may assume that the union  $\tilde{D}_+^*$  of all the components of  $\tilde{r} - \tilde{W}(\tilde{s})$  contained in  $\tilde{D}_+$  crosses at most  $w$  complementary components of  $\tilde{S}_0$ . The surface  $\tilde{r}_+ - \tilde{D}_+^*$  is contained in  $\tilde{W}(\tilde{s})$ . Hence it also has width at most  $w$ .

Consequently, the sphere  $\tilde{r}_+$  has width at most  $2w$ . By [Lemma 7.8](#), the width of its isotopy class with respect to  $\tilde{S}_0$  is at most  $2w$ . Since  $\tilde{r}_+$  is isotopic to a lift of  $r_+$ , the isotopy class of  $r_+$  has width at most  $2w$ , and the lemma is proved.  $\square$

As a consequence of [Lemmas 7.5, 7.9](#) and [7.6](#), we obtain [Theorem 7.1](#) from [Theorem 1.1](#) under hypothesis (ii) in the same way that we obtained [Theorem 3.1](#).

## 8 Nielsen realisation for graphs

Let  $\{s_1, \dots, s_k\}$  be a finite set of disjoint spheres in  $W$ . We say that  $\{s_1, \dots, s_k\}$  is a *simple sphere system* if the complementary components of  $s_1 \cup \dots \cup s_k$  are bordered 3-spheres or, equivalently, simply connected. A clique  $\Delta \subset S^0(W)$  is called *simple* if some (hence any) set of disjoint representatives of elements in  $\Delta$  is a simple sphere system. In this section, we use the results of [Section 7](#) to show the following.

**Theorem 8.1** *Let  $W$  be a (possibly disconnected) doubled handlebody, each component of which has rank at least 2. Let  $H$  be a finite subgroup of  $\text{Map}(W)$ . Then  $H$  fixes a simple clique in the sphere graph  $\mathcal{S}(W)$ .*

As an immediate consequence of [Theorem 8.1](#), we obtain [Theorem 1.5](#). Namely, let  $H$  be a finite subgroup of  $\text{Out}(F_n)$ . By [Theorem 8.1](#), the group  $H$  fixes a simple clique  $\Delta$  in  $\mathcal{S}(W_n)$  (see the discussion at the beginning of [Section 7](#)). Then  $H$  acts as isometries on the dual graph of a simple sphere system representing  $\Delta$ .

The proof of [Theorem 8.1](#) is similar to the one employed for the handlebody group in [Theorem 6.1](#), with one additional complication:

In the handlebody group case, if a finite group fixes a clique  $\Delta$  in the disc graph, then, using [Theorem 1.3](#) with hypothesis (B), there is an  $H$ -invariant hyperbolic metric on the boundary of the handlebody. We used curves of a certain type that minimise length with respect to this metric to extend  $\Delta$  to a simple clique.

The manifold  $W$  does not have a preferred geometry. We will instead imitate the length argument using a combinatorial and topological argument. The role of length will be played by the geometric intersection number of sphere systems with arc systems, which we define next.



## 8.1 Arc systems

We need a slight generalisation of the doubled handlebodies considered in [Section 7](#). Namely, let  $W_n^l$  be the 3-manifold obtained from  $W_n$  by removing  $l$  open balls. Let  $W_0$  be the disjoint union of a finite number of such manifolds.

An embedded sphere in  $W_0$  is called *essential* if it does not bound a ball in  $W_0$  and if it is not homotopic into a boundary component of  $W_0$ . The definitions of sphere systems and normal position then extend to the manifold  $W_0$  in a straightforward way. Furthermore, normal position has the same properties as described for  $W$  in [Section 7](#).

An *arc* is a proper embedding of an interval into  $W_0$ , where the endpoints are allowed to coincide. Let  $S$  be a simple sphere system in  $W_0$  and let  $a$  be an arc. We call the intersections of  $a$  with complementary components of  $S$  the *arc pieces of  $a$  with respect to  $S$* . An arc piece  $a' \subset a$  is called *returning* if its endpoints lie on the same boundary component of the complementary component of  $S$  containing  $a'$ . We say that an arc  $a$  is in *minimal position with respect to  $S$*  if no arc piece of  $a$  is returning.

**Lemma 8.2** *Let  $S, S'$  be two simple sphere systems in  $W_0$  that are in normal position, and let  $a$  be an arc. Then  $a$  can be homotoped to be in minimal position with respect to both  $S$  and  $S'$ .*

**Proof** We replace  $a$  with a homotopic arc in minimal position with respect to  $S'$  and intersecting  $S$  in the minimal possible number of points. We will prove that  $a$  is in minimal position with respect to  $S$ .

Otherwise, there is a returning arc piece  $a' \subset a$  with respect to  $S$ , contained in a complementary component  $K$  of  $S$ . Let  $n$  be the number of sphere pieces of  $S'$  in  $K$  intersected by  $a'$ . We will argue by induction that  $n$  can be decreased to 0.

If  $n = 0$ , then  $a'$  is disjoint from  $S'$ . We can then homotope the arc piece  $a'$  out of  $K$ , keeping  $a$  in minimal position with respect to  $S'$ . Such a homotopy decreases the number of intersection points between  $a$  and  $S$ . This contradicts the minimality assumption on  $a$ .

If  $n > 0$ , orient  $a'$ , and let  $P'$  be the first sphere piece of  $S'$  intersected by  $a'$ . Note that  $a'$  intersects  $P'$  in a single point since  $P'$  separates  $K$  into two connected components, and  $a$  has no returning arc piece with respect to  $S'$ . In particular, the sphere piece  $P'$  intersects the boundary component of  $K$  containing the endpoints of  $a'$ . Therefore we can slide  $a'$  along  $P'$ , keeping  $a$  in minimal position with respect to  $S'$  to decrease the number  $n$  of sphere pieces of  $S'$  in  $K$  intersected by  $a'$  (see [Figure 3](#)), as desired. Note that such a homotopy does not increase the number of intersection points between  $a$  and  $S$ .  $\square$

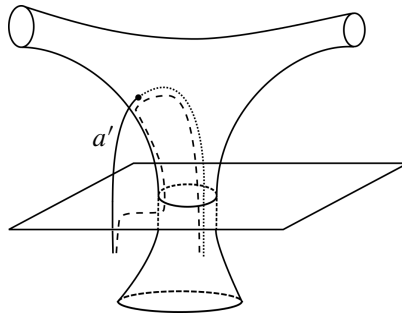

Figure 3: Sliding a returning arc piece to intersect fewer sphere pieces

If an arc  $a$  is in minimal position with respect to a simple sphere system  $S$ , then the number of intersection points between  $a$  and  $S$  depends only on the homotopy classes  $\alpha$  of  $a$  and  $\Sigma$  of  $S$ . It will be called the *intersection number*  $i(\alpha, \Sigma)$ .

An *arc system* in  $W_0$  is a finite collection of arcs in  $W_0$ . We say that an arc system  $A$  is *generating* if the following holds for each connected component  $\widehat{W}$  of  $W_0$ .

- (i) The graph whose vertices are boundary components of  $\widehat{W}$  and edges correspond to arcs of  $A$  in  $\widehat{W}$  is connected.
- (ii) There is a system of loops of  $A$  in  $\widehat{W}$  based at a point on  $\partial\widehat{W}$  that generates the fundamental group of  $\widehat{W}$ .

If  $A$  and  $A'$  are arc systems in the same homotopy class  $\Lambda$ , then  $A$  is generating if and only if  $A'$  is generating. In that case we also call  $\Lambda$  a *generating arc system*. The *intersection number*  $i(\Lambda, \Sigma)$  is the sum of  $i(\alpha, \Sigma)$  over all  $\alpha \in \Lambda$ .

**Lemma 8.3** *Let  $\Lambda$  be a generating arc system, and let  $k > 0$ . Then there are only finitely many isotopy classes  $\Sigma$  of simple sphere systems in  $W_0$  with intersection number  $i(\Lambda, \Sigma) \leq k$ .*

**Proof** The mapping class group of  $W_0$  acts with finite quotient on the set of isotopy classes of simple sphere systems. Thus there is a finite collection  $\{\Sigma_j^*\}_j$  of isotopy classes of simple sphere systems representing all the orbits. Let  $\Sigma$  be an isotopy class of a simple sphere system with  $i(\Lambda, \Sigma) < k$ . There is a mapping class  $\varphi$  of  $W_0$  with  $\varphi(\Sigma) = \Sigma_j^*$  for some  $j$ . For every  $\Sigma_j^*$  there are only finitely many homotopy classes  $\alpha$  of arcs with intersection number  $i(\alpha, \Sigma_j^*) \leq k$ . Therefore, there are only finitely many possible  $\varphi(\Lambda)$ . The lemma now follows from the following bound on the number of possible mapping classes  $\varphi$ .

**Claim** Suppose that  $\Lambda$  is a generating arc system. The subgroup of the mapping class group of  $W_0$  preserving each oriented arc  $\alpha \in \Lambda$  is finite.

To show the claim, let  $f$  be a homeomorphism of  $W_0$  such that the arc  $f(a)$  is homotopic to  $a$  for each oriented arc  $a \in A$ , where  $A$  represents  $\Lambda$ . Let  $\widehat{W}$  be a connected component of  $W_0$  with  $l$  boundary components. If  $l > 1$ , let  $s_1, s_2$  be two boundary components of  $\widehat{W}$  that are connected by an arc  $a \in A$ . These exist by property (i) of a generating arc system. Let  $s$  be the boundary of a regular neighbourhood of  $s_1 \cup a \cup s_2$ . Since  $f$  preserves the homotopy class of  $a$ , it also preserves the homotopy classes of  $s_1$  and  $s_2$ . Thus the sphere  $s$  is homotopic, hence isotopic, to  $f(s)$ . The complement of  $s$  in  $\widehat{W}$  is the disjoint union of  $W_n^{l-1}$  (for a suitable  $n \geq 1$ ) and a 3-sphere minus three open balls. The intersection  $A \cap W_n^{l-1}$  becomes a generating arc system in  $W_n^{l-1}$  after a homotopy. Arguing inductively using property (i) of a generating arc system, we find a sphere  $\widehat{s}$  such that the following holds. The complement of  $\widehat{s}$  is the disjoint union of  $W_n^1$  and a 3-sphere minus  $l + 1$  open balls. Up to isotopy, the homeomorphism  $f$  preserves  $\widehat{s}$ . The restriction of  $f$  to  $W_n^1$  preserves the homotopy class of a generating arc system. Now property (ii) of a generating arc system implies that  $f$  acts as the identity on the fundamental group of  $W_n^1$ . By Laudenbach [21, Theorem 4.3],  $f$  represents an element of a finite subgroup of the mapping class group of  $\widehat{W}$ .  $\square$

## 8.2 Fibres

Let  $W'$  be the manifold obtained by gluing closed balls to each of the boundary spheres of  $W_0$ . There is a natural embedding  $W_0 \rightarrow W'$ . Let  $\Delta'$  be a clique in  $\mathcal{S}^0(W')$ , and let  $\{s'_1, \dots, s'_k\}$  be a sphere system in  $W'$  representing  $\Delta'$ . We define  $\mathcal{F}(\Delta')$  to be the following graph. The vertex set of  $\mathcal{F}(\Delta')$  is the set of isotopy classes  $\Delta$  of sphere systems  $\{s_1, \dots, s_k\}$  in  $W_0$  such that  $s_i$  is isotopic to  $s'_i$ , viewed as spheres in  $W'$ . Two vertices are connected by an edge if the corresponding sphere systems can be realised in  $W_0$  disjointly.

Let  $\Lambda$  be a generating arc system in  $W_0$  and put

$$I = I(\Lambda, \Delta') = \min\{i(\Lambda, \Delta) \mid \Delta \in \mathcal{F}(\Delta')\}.$$

Let  $\mathcal{F}^\Lambda(\Delta')$  be the subgraph of  $\mathcal{F}(\Delta')$  induced on the set of the vertices  $\Delta$  of  $\mathcal{F}(\Delta')$  satisfying  $i(\Lambda, \Delta) = I$ . By Lemma 8.3, the graph  $\mathcal{F}^\Lambda(\Delta')$  is finite.

**Lemma 8.4** *The graph  $\mathcal{F}^\Lambda(\Delta')$  is dismantlable.*

**Proof** We will show that  $\mathcal{F}^\Lambda(\Delta')$  is dismantlable by defining a dismantling projection.

Let  $S_1$  and  $S_2$  be two sphere systems representing vertices of  $\mathcal{F}(\Delta')$  that intersect and that are in normal position. Since  $S_1$  and  $S_2$  are homotopic in  $W'$ , there are discs  $D_i \subset S_i$  with common boundary circle such that  $D_1 \cup D_2$  bounds a ball in  $W'$  disjoint from  $S_1 \cup S_2$ . We say that such discs  $D_i$  are *admissible surgery discs*.

By [Lemma 8.2](#), we may choose a generating arc system  $A$  representing  $\Lambda$  in minimal position with respect to both  $S_1$  and  $S_2$ . The isotopy classes of the sphere systems  $(S_1 - D_1) \cup D_2$  and  $(S_2 - D_2) \cup D_1$  define vertices of  $\mathcal{F}(\Delta')$ . By minimality of  $I$ , the arc system  $A$  intersects  $D_1$  in the same number of points as  $D_2$ . In particular, the sphere system  $(S_1 - D_1) \cup D_2$  represents a vertex of  $\mathcal{F}^\Lambda(\Delta')$ .

We call  $(S_1 - D_1) \cup D_2$  an *admissible surgery of  $S_1$  in the direction of  $S_2$* . Since normal position is unique, the isotopy classes of admissible surgeries only depend on the isotopy classes  $\Sigma_1, \Sigma_2$  of the sphere systems  $S_1$  and  $S_2$ . Let  $\Pi_{\Sigma_2}(\Sigma_1)$  be the set of all such admissible surgeries (each of which is interpreted as a pair whose two elements coincide).

[Lemma 7.4](#) holds for  $W_0$  with the same proof as for  $W$ . Hence, arguing exactly as in the proof of [Lemma 7.5](#), one shows that  $\Pi_{\Sigma_2}$  is a dismantling projection for each  $\Sigma_2 \in \mathcal{F}^\Lambda(\Delta')$ .  $\square$

**Proof of [Theorem 8.1](#)** We prove the theorem by induction on the sum of the ranks of the components of  $W$  minus the number of components of  $W$ . By [Theorem 7.1](#), the subgroup  $H$  fixes a clique  $\Delta$  in  $\mathcal{S}(W)$ . Let  $S = \{s_1, \dots, s_n\}$  be a sphere system representing  $\Delta$ . If every complementary component of  $S$  is a bordered 3–sphere, then  $\Delta$  is already simple. Otherwise, let  $W_0$  be the union of all the complementary components of  $S$  which are not bordered 3–spheres. The finite group  $H$  acts as a group of mapping classes on  $W_0$ .

Let  $W'$  be the manifold obtained by gluing closed balls to each boundary component of  $W_0$ . There is an  $H$ –invariant simple clique  $\Delta' \subset \mathcal{S}^0(W')$ : in each rank-1 component of  $W'$ , we consider the unique homotopy class of spheres; in the union of the remaining components of  $W'$  there is a simple sphere system that is  $H$ –invariant up to isotopy by the induction hypothesis.

Let  $\Lambda$  be a generating arc system in  $W_0$  that is fixed by  $H$ . Such a system can be obtained as the orbit of an arbitrary generating arc system. Since  $H$  preserves both  $\Lambda$  and  $\Delta'$ , it acts by automorphisms on  $\mathcal{F}^\Lambda(\Delta')$ . By [Lemma 8.4](#), the graph  $\mathcal{F}^\Lambda(\Delta')$  is dismantlable. Therefore, by [Theorem 1.1](#) under hypothesis (i), the group  $H$  fixes a clique  $\Delta^*$  in  $\mathcal{F}^\Lambda(\Delta')$ . Since  $\Delta'$  is a simple clique, the vertices of  $\Delta^*$  can be realised

as a simple sphere system in  $W_0$ . We can interpret  $\Delta^*$  as a clique in  $\mathcal{S}^0(W)$ , which together with  $\Delta$  forms the desired simple clique fixed by  $H$ .  $\square$

**Remark 8.5** In fact, one can show that if  $W'$  does not have rank-1 components, then the flag complex spanned on the graph  $\mathcal{F}(\Delta')$  is isomorphic to a triangulation of a product of trees with orthoschemes. The number of factors is the number of boundary components of  $W_0$ . In the case where  $W_0$  has one boundary component, this means that  $\mathcal{F}(\Delta')$  is a tree. That case can be proved for example by extending the dismantling projection from  $\mathcal{F}^\Lambda(\Delta')$  (see Lemma 8.4) to the whole  $\mathcal{F}(\Delta')$ . This fact is analogous to a result of Kent, Leininger and Schleimer [16, Theorem 7.1] for the curve graph of a surface with one puncture. In the case where  $W_0$  has more boundary components, recognising the product of trees structure requires local analysis of  $\mathcal{F}(\Delta')$ .

## 9 Contractibility of the set of fixed points

This section is a continuation of Section 2. The main result is the combinatorial Theorem 1.2 stating that, in a finite flag simplicial complex with dismantlable 1–skeleton, the set of points fixed by an automorphism group is contractible. It is a significant extension of Theorem 2.4, and according to our knowledge it is a new result.<sup>1</sup> Theorem 1.2 is of independent interest in graph theory, and as we will see it has numerous applications in geometric group theory. We will use it to obtain Theorem 1.6 in Section 12. At the end of the current section, we will deduce from Theorem 1.2 a criterion for contractibility of fixed point sets in the presence of dismantling projections (Proposition 9.2). This will allow us to prove Metatheorems B and C.

We adopt a convention that in a flag simplicial complex, a *neighbourhood* of a vertex is its neighbourhood in the 1–skeleton. Similarly, a vertex is *dominated* (resp. *dominating*) if it is dominated (resp. dominating) in the 1–skeleton, etc.

**Proof of Theorem 1.2** First observe that  $Y^H$  is nonempty, by Theorem 2.4. The proof of the theorem is by induction on the number  $|V|$  of vertices of  $Y$ . If  $|V| = 1$ , then the assertion is clear. Now, for a given  $Y$  assume that the theorem has been proved for all complexes with less than  $|V|$  vertices. We treat two cases separately (as in the proof of Theorem 2.4).

**Case 1** There exist no two vertices with common neighbourhood. In this case let  $V' \subset V$  be the nonempty set of dominated vertices that are not dominating. Note that the subcomplex  $Y'$  spanned on  $V \setminus V'$  is  $H$ –invariant, dismantlable (by Lemma 2.5), with less than  $|V|$  vertices. By induction hypothesis,  $Y'^H$  is contractible.

<sup>1</sup>After the acceptance of the paper we found out that this result was earlier proved in [1].

For every vertex  $\sigma \in V'$ , let  $\sigma^{\text{dom}}$  denote the simplex of  $Y$  spanned on the set of all vertices dominating  $\sigma$ . Observe that  $\sigma^{\text{dom}}$  is contained in  $Y'$ . For  $\sigma \in V \setminus V'$ , put  $\sigma^{\text{dom}} = \sigma$ . By  $b_{\sigma^{\text{dom}}}$  we denote the barycentre of  $\sigma^{\text{dom}}$ . On the (geometric realisation of the) simplicial complex  $Y$ , define a deformation retraction  $\mathcal{R}: Y \times [0, 1] \rightarrow Y$  as follows. First we define  $\mathcal{R}$  on vertices of  $Y$  by setting  $\mathcal{R}(\sigma, t) = (1 - t)\sigma + tb_{\sigma^{\text{dom}}}$ , where the linear combination is taken with respect to the standard affine structure on  $Y$ . If the set  $S = \{\sigma_1, \dots, \sigma_k\} \subset V$  of vertices spans a simplex of  $Y$ , then there exists a simplex  $\Delta$  of  $Y$  containing  $S$  and all the simplices  $\sigma_i^{\text{dom}}$ . Thus, for every  $t$  the set  $\{\mathcal{R}(\sigma_1, t), \dots, \mathcal{R}(\sigma_k, t)\}$  is contained in  $\Delta$ . It follows that we may extend  $\mathcal{R}$  affinely to a map on  $Y \times [0, 1]$ . Observe that  $\mathcal{R}(Y \times \{1\}) = Y'$ .

Since for every vertex  $\sigma \in V$  we have  $H(\sigma^{\text{dom}}) = (H\sigma)^{\text{dom}}$ , the map  $\mathcal{R}$  is  $H$ -equivariant (with the trivial  $H$ -action on  $[0, 1]$ ). Thus, if the set  $\{\sigma_1, \dots, \sigma_k\}$  of vertices of  $Y$  spans an  $H$ -invariant simplex, then the set  $\{\mathcal{R}(\sigma_1, t), \dots, \mathcal{R}(\sigma_k, t)\}$  is  $H$ -invariant for every  $t$ . It follows that the image  $\mathcal{R}(b, t)$  of the barycentre  $b$  of an  $H$ -invariant simplex of  $Y$  is a point fixed by  $H$ . Moreover, every point  $x \in Y$  fixed by  $H$  is an affine combination of such barycentres, thus  $\mathcal{R}(x, t)$  is fixed by  $H$ . Thus the image  $\mathcal{R}(Y^H, t)$  of the set of the points fixed by  $H$  consists itself of fixed points. We obtain a deformation retraction  $\mathcal{R}|_{Y^H \times [0, 1]}$  of  $Y^H$  to  $\mathcal{R}(Y^H \times \{1\})$ . Since  $\mathcal{R}(Y^H \times \{1\})$  is isomorphic to  $Y'^H$ , which is contractible, we conclude that  $Y^H$  is contractible.

**Case 2** There exist different vertices of  $Y$  having common neighbourhood. In that case consider the graph  $\Gamma'$  obtained by identifying all vertices with common neighbourhood (as in the proof of [Theorem 2.4](#)). Let  $Y'$  denote the corresponding flag simplicial complex, ie,  $Y' = \Gamma'^{\blacktriangle}$ . The  $H$ -action on  $Y$  induces an  $H$ -action on  $Y'$ , and  $\Gamma'$  is dismantlable by [Lemma 2.5](#) (see the proof of [Theorem 2.4](#)). Thus, by induction hypothesis,  $Y'^H$  is contractible.

Observe that for every vertex  $\sigma$  of  $\Gamma$ , the set of vertices with the same neighbourhood as  $\sigma$  spans a simplex  $\Delta^\sigma$  of  $Y$ . Moreover, two such simplices  $\Delta^\sigma \neq \Delta^\rho$  are disjoint. Define a deformation retraction  $\mathcal{R}: Y \times [0, 1] \rightarrow Y$  as follows. First we define  $\mathcal{R}$  on vertices of  $Y$  by setting  $\mathcal{R}(\sigma, t) = (1 - t)\sigma + tb_{\Delta^\sigma}$ . Note that if vertices  $\sigma_1, \dots, \sigma_k$  of  $Y$  are pairwise connected by edges (ie, when they span a simplex), then for every  $t$  all the images  $\mathcal{R}(\sigma_1, t), \dots, \mathcal{R}(\sigma_k, t)$  are contained in a common simplex of  $Y$ . Hence  $\mathcal{R}$  can be affinely extended to a map  $\mathcal{R}: Y \times [0, 1] \rightarrow Y$ . Let  $\mathcal{T}$  be the flag triangulation of  $\mathcal{R}(Y \times \{1\})$  defined as follows. Vertices of  $\mathcal{T}$  are the points  $b_{\Delta^\sigma}$ , for all vertices  $\sigma$  of  $Y$ . Edges are straight segments connecting  $b_{\Delta^\sigma}$  and  $b_{\Delta^\rho}$ , whenever  $\sigma$  and  $\rho$  are connected by an edge of  $Y$ . Simplices are convex hulls of cliques. Observe that  $\mathcal{T}$  is isomorphic to  $Y'$ .

Similarly, as in the previous case we see that the map  $\mathcal{R}$  is  $H$ -invariant. Thus, again, if the set  $\{\sigma_1, \dots, \sigma_k\}$  of vertices of  $Y$  spans an  $H$ -invariant simplex, then for every  $t$  the set  $\{\mathcal{R}(\sigma_1, t), \dots, \mathcal{R}(\sigma_k, t)\}$  is  $H$ -invariant. Analogously to the previous case, we conclude that we obtain a deformation retraction  $\mathcal{R}|_{Y^H \times [0,1]}$  of  $Y^H$  to  $\mathcal{R}(Y^H \times \{1\})$ . Observe that the latter space is isomorphic (as a subcomplex of the barycentric subdivision of the triangulation  $\mathcal{T}$ ) to  $Y'^H$ , which is contractible.  $\square$

**Definition 9.1** Assume that for every vertex  $\sigma$  of a graph  $\Gamma$  with vertex set  $V$ , we have a  $\sigma$ -projection  $\Pi_\sigma$ . The family  $\{\Pi_\sigma\}_\sigma$  is *synchronised* if for any clique  $\Delta \subset V$  and any sequence  $\rho_1, \rho_2, \dots$  with  $\rho_{i+1} \in \Pi_{\sigma_i}^*(\rho_i)$  with any  $\sigma_i \in \Delta$ , the sequence  $(\rho_i)_i$  enters (and then stays in)  $\Delta$ .

**Proposition 9.2** Let  $H$  be a group of automorphisms of a graph  $\Gamma$  with vertex set  $V$  without infinite cliques. Assume that we have a  $\sigma$ -projection  $\Pi_\sigma$  for each  $\sigma \in V$ , and the family  $\{\Pi_\sigma\}_\sigma$  is  $H$ -equivariant. Suppose that

- (i)  $H$  fixes a vertex of  $\Gamma$ , or
- (ii)  $H$  fixes a clique in  $\Gamma$  and the family  $\{\Pi_\sigma\}_\sigma$  is synchronised.

Then the fixed point set  $(\Gamma^\blacktriangle)^H$  is contractible.

**Proof** We first prove the proposition under hypothesis (ii). Recall that for  $S \subset V$ , the subcomplex of  $\Gamma^\blacktriangle$  spanned on  $S$  is denoted by  $S^\blacktriangle$ . In particular,  $\Gamma^\blacktriangle = V^\blacktriangle$ .

Let  $S \subset V$  be the union of the vertices of all  $H$ -invariant cliques. We can exhaust  $S$  by an increasing sequence  $S_1, S_2, \dots$  of finite  $H$ -invariant sets. Choose an  $H$ -invariant clique  $\Delta \subset S$ .

Let  $R_n \subset V$  be the minimal set containing  $S_n$ , and with the property that for any  $\rho \in R_n$  and  $\sigma \in \Delta$ , all the elements of  $\Pi_\sigma^*(\rho)$  lie in  $R_n$  as well. Since  $S_n$  is finite, the set  $R_n$  is finite by the fact that  $\{\Pi_\sigma\}_\sigma$  is synchronised, and by König's lemma. Since both  $\Delta$  and  $S_n$  are  $H$ -invariant and  $\{\Pi_\sigma\}_\sigma$  is  $H$ -equivariant, the set  $R_n$  is  $H$ -invariant as well.

Hence the  $R_n$  are finite  $H$ -invariant sets that contain  $S_n$  and are  $\Pi_\sigma$ -convex for each  $\sigma \in \Delta$ . The subcomplexes  $R_n^\blacktriangle$  exhaust  $S^\blacktriangle$ , which contains  $(V^\blacktriangle)^H$ . By Corollary 2.9, the subgraph induced on each  $R_n$  is dismantlable. By Theorem 1.2, each  $(R_n^\blacktriangle)^H$  is contractible and hence  $(V^\blacktriangle)^H$  is contractible, as desired.

Under hypothesis (i), we can take  $\Delta$  to be a vertex and we can use axiom (ii) of a dismantling projection to obtain that  $R_n$  is finite. The remaining part of the argument is the same.  $\square$

## 10 Contractibility of fixed point sets in the arc complex

In this section we prove Metatheorems **B** and **C** for the mapping class group (Theorems 10.1 and 10.3). The *arc complex*  $\mathcal{A}^\blacktriangle(X)$  is the flag simplicial complex obtained from the arc graph  $\mathcal{A}(X)$  by spanning simplices on all of its cliques. Then simplices of  $\mathcal{A}^\blacktriangle(X)$  correspond to sets of disjoint arcs.

**Theorem 10.1** *Let  $X$  be a closed connected oriented surface with a nonempty set of marked points and negative Euler characteristic. Let  $H$  be any subgroup of  $\text{Map}(X)$ . Then the set  $\mathcal{A}^\blacktriangle(X)^H$  of points of the arc complex  $\mathcal{A}^\blacktriangle(X)$  fixed by  $H$  is empty or contractible.*

Hence in view of Theorem 3.1 in the particular case where  $H$  is finite, the fixed point set  $\mathcal{A}^\blacktriangle(X)^H$  is contractible. Also, if we take for  $H$  the trivial group, it follows that  $\mathcal{A}^\blacktriangle(X)$  is contractible, which was proved in [11; 13].

**Lemma 10.2** *The family  $\{\Pi_\sigma\}_\sigma$  of dismantling projections on  $\mathcal{A}(X)$  from Section 3 is synchronised.*

**Proof** Choose a clique  $\Delta \subset \mathcal{A}^0(X)$  and any sequence  $\rho_1, \rho_2, \dots$  with  $\rho_{i+1} \in \Pi_{\sigma_i}^*(\rho_i)$  with some  $\sigma_i \in \Delta$ . Then, as in the proof of Lemma 3.2(ii), the geometric intersection number between  $\rho_i$  and the set  $\Delta$  of disjoint arcs decreases until  $\rho_i \in \Delta$ , as desired.  $\square$

**Proof of Theorem 10.1** Assume that  $\mathcal{A}^\blacktriangle(X)^H$  is nonempty, ie  $H$  fixes a clique in  $\mathcal{A}(X)$ . Cliques in  $\mathcal{A}(X)$  are finite. The family  $\{\Pi_\sigma\}_\sigma$  of dismantling projections on  $\mathcal{A}(X)$  from Lemma 3.2 is  $H$ -equivariant (Lemma 3.3) and synchronised (Lemma 10.2). Hence by Proposition 9.2 under hypothesis (ii), the fixed point set  $\mathcal{A}^\blacktriangle(X)^H$  is contractible.  $\square$

Denote by  $\mathcal{A}_{\text{fill}}^0(X)$  the barycentres of simplices of  $\mathcal{A}^\blacktriangle(X)$  spanned on filling cliques. Let  $\mathcal{A}_{\text{fill}}^\blacktriangle(X)$  be the subcomplex of the barycentric subdivision of  $\mathcal{A}^\blacktriangle(X)$  spanned on  $\mathcal{A}_{\text{fill}}^0(X)$ . We call  $\mathcal{A}_{\text{fill}}^\blacktriangle(X)$  the *filling arc system complex*. The stabiliser in  $\text{Map}(X)$  of a vertex (or a simplex) of  $\mathcal{A}_{\text{fill}}^\blacktriangle(X)$  is finite. Conversely, we have proved in Theorem 4.1 that for each finite subgroup  $H \subset \text{Map}(X)$ , the fixed point set  $\mathcal{A}_{\text{fill}}^\blacktriangle(X)^H$  contains a vertex. We extend this to the following.

**Theorem 10.3** *Let  $X$  be a closed connected oriented surface with nonempty set of marked points and negative Euler characteristic. Let  $H$  be a finite subgroup of  $\text{Map}(X)$ . Then the set  $\mathcal{A}_{\text{fill}}^\blacktriangle(X)^H$  of points in the filling arc system complex  $\mathcal{A}_{\text{fill}}^\blacktriangle(X)$  fixed by  $H$  is contractible.*



Before we give the proof of [Theorem 10.3](#), we note that consequently we obtain the following.

**Corollary 10.4** *Let  $X$  be a closed connected oriented surface with nonempty set of marked points and negative Euler characteristic. The filling arc system complex  $\mathcal{A}_{\text{fill}}^{\blacktriangle}(X)$  is a finite model for  $\underline{E} \text{Map}(X)$ ; the classifying space for proper actions for  $\text{Map}(X)$ .*

Harer’s spine of the Teichmüller space of  $X$  (see [12]) is the subcomplex of  $\mathcal{A}_{\text{fill}}^{\blacktriangle}(X)$  spanned on the vertices involving arcs starting and terminating on a distinguished marked point. Hence in the case of one marked point,  $\mathcal{A}_{\text{fill}}^{\blacktriangle}(X)$  coincides with Harer’s spine. The proof of [Theorem 10.3](#) carries over to the action of the pure mapping class group of  $X$  on Harer’s spine.

**Corollary 10.5** *Let  $X$  be a closed connected oriented surface with nonempty set of marked points and negative Euler characteristic. Then Harer’s spine of the Teichmüller space of  $X$  is a finite model for the classifying space for proper actions for the pure mapping class group of  $X$ .*

The dimension of Harer’s spine coincides with the virtual cohomological dimension of  $\text{Map}(X)$ , so it is efficient in this sense.

The proof of [Theorem 10.3](#) relies on defining a surgery procedure for filling arc sets. In order to preserve the property of being filling, we will now need to include in the surgered set both arcs obtained by outermost surgery. This will give rise to a dismantling projection on the 1–skeleton of the filling arc system complex.

**Proof of [Theorem 10.3](#)** Let  $\Delta \in \mathcal{A}_{\text{fill}}^0(X)^H$ , which is nonempty by [Theorem 4.1](#). We construct a  $\Delta$ –projection  $\Pi_{\Delta}$  on the 1–skeleton  $\mathcal{A}_{\text{fill}}(X)$  of  $\mathcal{A}_{\text{fill}}^{\blacktriangle}(X)$ . Let  $\Sigma \in \mathcal{A}_{\text{fill}}^0(X)$  be any vertex distinct from  $\Delta$ . Every pair  $\{\Pi_1, \Pi_2\} \in \Pi_{\Delta}(\Sigma)$  will satisfy  $\Pi_1 = \Pi_2$ , so  $\Pi_{\Delta}(\Sigma)$  will be determined by  $\Pi_{\Delta}^*(\Sigma)$ .

Note that  $\Delta, \Sigma$  can be interpreted as filling sets of (homotopy classes of) disjoint arcs. If all the arcs in  $\Delta, \Sigma$  are disjoint, we put  $\Pi_{\Delta}^*(\Sigma) = \{\Delta\}$ . Otherwise, realise the homotopy classes of arcs  $\Delta, \Sigma$  as families of genuine arcs  $A, S \subset X$  in minimal position. Choose an arc  $a \in A$  intersecting  $S$ . Let  $b \subset a$  be a component of  $a - S$  sharing an endpoint with  $a$ . Let  $s \in S$  be the arc containing the endpoint of  $b$  in the interior of  $a$ . Consider  $s_+, s_-$  obtained by outermost surgery of  $s$  in the direction of  $a$  determined by  $b$ . Let  $P = S \cup \{s_+, s_-\} \setminus \{s\}$ . Note that  $P$  is filling, since any simple closed curve that is disjoint from both  $s_+, s_-$  up to homotopy is also disjoint from  $s$

up to homotopy. Define  $\Pi_{\Delta}^*(\Sigma)$  to be the set of homotopy classes of all possible  $P$ , under all choices of  $a$  and  $b$ . This does not depend on the realisations  $A, S$  of  $\Delta, \Sigma$ .

The assignment  $\Pi_{\Delta}(\Sigma)$  determined by  $\Pi_{\Delta}^*(\Sigma)$  satisfies the axioms of a  $\Delta$ -projection by the same argument as in the proof of [Lemma 3.2](#):

For axiom (i), we consider the surface  $\check{X}$  obtained from  $X$  by replacing each marked point with a boundary component, and we put a hyperbolic metric with geodesic boundary on  $\check{X}$ . We realise all the arcs of  $\Delta$  and the arbitrary set  $R = \{\Sigma_1, \dots, \Sigma_k\} \subset \mathcal{A}_{\text{fill}}^0(X)$  as families  $A, S_1, \dots, S_k$  of shortest geodesic arcs on  $\check{X}$ . Choose any arc  $a \in A$  intersecting  $\bigcup_{i=0}^k S_i$ . Let  $b$  be a component of  $a - \bigcup_{i=0}^k S_i$  sharing an endpoint with  $a$ . Choose  $S_j$  so that it contains the endpoint of  $b$  in the interior of  $a$ . Let  $\Pi \in \Pi_{\Delta}^*(\Sigma_j)$  be obtained by surgery determined by  $b$ . Then  $N(\Pi) \supset N(\Sigma_j) \cap R$ , as desired.

For axiom (ii), we observe that the sum of the geometric intersection numbers between all of the arcs of  $\Delta$  and all of the arcs of any element of  $\Pi_{\Delta}^*(\Sigma)$  is less than the corresponding sum for  $\Delta$  and  $\Sigma$ .

The map  $\Pi_{\Delta}$  is  $H$ -equivariant and cliques in  $\mathcal{A}_{\text{fill}}(X)$  are finite. Hence by [Proposition 9.2](#) under hypothesis (i), the fixed point set  $\mathcal{A}_{\text{fill}}^{\Delta}(X)^H$  is contractible, as desired.  $\square$

## 11 Contractibility of fixed point sets in the disc and sphere complexes

In this section we prove [Metatheorems B](#) and [C](#) for the handlebody group and  $\text{Out}(F_n)$ .

### 11.1 Disc complex

The *disc complex*  $\mathcal{D}^{\Delta}(U)$  is the flag simplicial complex obtained from the disc graph  $\mathcal{D}(U)$  by spanning simplices on all of its cliques. Then simplices of  $\mathcal{D}^{\Delta}(U)$  correspond to sets of disjoint discbounding curves.

**Theorem 11.1** *Let  $U$  be a connected handlebody of genus at least 2. Let  $H$  be any subgroup of  $\text{Map}(U)$ . Then the set  $\mathcal{D}^{\Delta}(U)^H$  of points of the disc complex  $\mathcal{D}^{\Delta}(U)$  fixed by  $H$  is empty or contractible.*

**Proof** Cliques in  $\mathcal{D}(U)$  are finite. The family of dismantling projections for  $\mathcal{D}(U)$  from [Lemma 5.3](#) is  $H$ -equivariant by [Lemma 5.4](#). It is also synchronised, which is proved exactly as [Lemma 10.2](#). By [Proposition 9.2](#) under hypothesis (ii), if the set  $\mathcal{D}^{\Delta}(U)^H$  is nonempty, then it is contractible.  $\square$

Let  $\mathcal{D}_{\text{simp}}^0(U)$  be the set of barycentres of simplices in  $\mathcal{D}^\blacktriangle(U)$  spanned on simple cliques. The *simple disc system complex*  $\mathcal{D}_{\text{simp}}^\blacktriangle(U)$  is the subcomplex of the barycentric subdivision of  $\mathcal{D}^\blacktriangle(U)$  spanned on  $\mathcal{D}_{\text{simp}}^0(U)$ .

**Theorem 11.2** *Let  $U$  be a connected handlebody of genus at least 2. Let  $H$  be a finite subgroup of  $\text{Map}(U)$ . Then the set  $\mathcal{D}_{\text{simp}}^\blacktriangle(U)^H$  of points of the simple disc system complex  $\mathcal{D}_{\text{simp}}^\blacktriangle(U)$  fixed by  $H$  is contractible.*

Note that the simple disc system complex  $\mathcal{D}_{\text{simp}}^\blacktriangle(U)$  is not a finite model for  $\underline{E} \text{Map}(U)$ , since stabilisers of simple disc systems are not all finite (they extend to braid groups).

**Proof** By [Theorem 6.1](#), the fixed point set  $\mathcal{D}_{\text{simp}}^\blacktriangle(U)^H$  contains a vertex  $\Delta \in \mathcal{D}_{\text{simp}}^0(U)$ .

We define a  $\Delta$ -projection  $\Pi_\Delta$  on the 1-skeleton of  $\mathcal{D}_{\text{simp}}^\blacktriangle(U)$ . Let  $\Sigma \in \mathcal{D}_{\text{simp}}^0(U) \setminus \{\Delta\}$ . If all the discbounding curves of  $\Delta$  and  $\Sigma$  are disjoint up to homotopy, we put  $\Pi_\Delta^*(\Sigma) = \{\Delta\}$ . Otherwise, we realise  $\Delta, \Sigma$  as families of disjoint discbounding curves  $D, S \subset \partial U$  pairwise in minimal position. Consider a subarc  $a \subset d$  for some  $d \in D$  that is outermost in a disc bounded by  $d$  for a disc bounded by some  $s \in S$ . Assume that  $a$  does not contain any other such outermost subarc. For any such subarc  $a$ , we consider  $P = S \cup \{s_+, s_-\} \setminus \{s\}$ , where  $s_+, s_-$  are obtained by outermost surgery of  $s$  in the direction of  $d$  determined by  $a$ . The set  $P$  is a simple disc system, and we define  $\Pi_\Delta^*(\Sigma)$  to be the set of all homotopy classes of all  $P$  constructed using all such subarcs  $a$ . This does not depend on the realisations  $D, S$  of  $\Delta, \Sigma$ . Let  $\Pi_\Delta(\Sigma)$  be the family of pairs  $\{\Pi_1, \Pi_2\}$ , where  $\Pi_1 = \Pi_2 \in \Pi_\Delta^*(\Sigma)$ .

We leave it to the reader to verify that  $\Pi_\Delta$  satisfies the axioms of a dismantling projection and that it is  $H$ -equivariant. This can be carried out exactly as in the proof of [Theorem 10.3](#), building upon the proof of [Lemma 5.3](#). Since cliques in  $\mathcal{D}_{\text{simp}}^\blacktriangle(U)$  are finite, by [Proposition 9.2](#) under hypothesis (i) the fixed point set  $\mathcal{D}_{\text{simp}}^\blacktriangle(U)^H$  is contractible. □

## 11.2 Sphere complex

The *sphere complex*  $\mathcal{S}^\blacktriangle(W)$  is the flag simplicial complex obtained from the sphere graph  $\mathcal{S}(W)$  by spanning simplices on all of its cliques. Then simplices of  $\mathcal{S}^\blacktriangle(W)$  correspond to sets of disjoint spheres.

**Theorem 11.3** *Let  $W$  be a doubled connected handlebody of rank  $n \geq 2$ . Let  $H$  be any subgroup of  $\text{Map}(W)$  or  $\text{Out}(F_n)$ . Then the set  $\mathcal{S}^\blacktriangle(W)^H$  of points of the sphere complex  $\mathcal{S}^\blacktriangle(W)$  fixed by  $H$  is empty or contractible.*

We omit the proof since it is carried out exactly as the proofs of Theorems 10.1 and 11.1.

Let  $\mathcal{S}_{\text{simp}}^0(W)$  be the set of barycentres of simplices in  $\mathcal{S}^\Delta(W)$  spanned on simple cliques. The *simple sphere system complex*  $\mathcal{S}_{\text{simp}}^\Delta(W)$  is the subcomplex of the barycentric subdivision of  $\mathcal{S}^\Delta(W)$  spanned on  $\mathcal{S}_{\text{simp}}^0(W)$ . The simple sphere system complex is the spine of the Culler–Vogtmann Outer space [14]. Our method gives a new proof of the following.

**Theorem 11.4** [32; 20] *Let  $W$  be a doubled connected handlebody of genus  $n \geq 2$ . Let  $H$  be a finite subgroup of  $\text{Map}(W)$  or  $\text{Out}(F_n)$ . Then the set  $\mathcal{S}_{\text{simp}}^\Delta(W)^H$  of points of the simple sphere system complex  $\mathcal{S}_{\text{simp}}^\Delta(W)$  fixed by  $H$  is contractible.*

**Corollary 11.5** [32; 20] *Let  $W$  be a doubled connected handlebody of genus  $n \geq 2$ . The simple sphere system complex  $\mathcal{S}_{\text{simp}}^\Delta(W)$  is a finite model for  $\underline{E} \text{Map}(W)$  and  $\underline{E} \text{Out}(F_n)$ .*

We leave the proof of Theorem 11.4 to the reader. It requires defining a dismantling projection on the 1–skeleton of  $\mathcal{S}_{\text{simp}}^\Delta(W)$  in the same way as it was done in Theorems 10.3 and 11.2 for the filling arc system complex and the simple disc system complex. To verify that it satisfies the axioms of a dismantling projection, one needs to invoke the proof of Lemma 7.5.

## 12 Rips complex

In this section we prove Theorem 1.6, which says that if a group  $G$  is  $\delta$ –hyperbolic and  $D \geq 8\delta + 1$ , then the Rips complex  $P_D(G)$  is a finite model for  $\underline{E}G$ .

We say that a graph is  $\delta$ –hyperbolic, with  $\delta \in \mathbb{N}$ , if for any vertices  $u, v, w$ , for any geodesics  $uv, vw, wu$ , and for any vertex  $t$  on  $uv$ , there is a vertex on  $vw \cup wu$  at distance at most  $\delta$  from  $t$ . A finitely generated group  $G$  is  $\delta$ –hyperbolic if its Cayley graph with respect to some finite generating set is  $\delta$ –hyperbolic. For  $D \in \mathbb{N}$ , the *Rips complex*  $P_D(G)$  is the flag simplicial complex with vertex set  $G$ , and edges connecting two vertices at distance at most  $D$  in the Cayley graph.

Theorem 1.6 is an immediate consequence of Theorem 1.2 and Lemma 12.1 below.

**Lemma 12.1** *Let  $G$  be a  $\delta$ –hyperbolic group and let  $D \geq 8\delta + 1$ . Let  $H$  be a finite subgroup of  $G$ . For every finite subset  $S$  of  $G$ , there exists an  $H$ –invariant finite dismantlable subgraph of the 1–skeleton of  $P_D(G)$  containing  $S$ .*

**Proof** If  $\delta = 0$ , then the Cayley graph of  $G$  is a tree ( $G$  is a free group) and the lemma follows from the fact that for any finite tree, the graph obtained after connecting by edges vertices at distance at most  $D$  is dismantlable. We can now assume  $\delta \geq 1$ .

The ball  $B_R(C)$  of radius  $R \in \mathbb{N}$  around a subset  $C$  of the vertex set  $G$  of the Cayley graph is the set all of vertices at distance at most  $R$  from some vertex in  $C$ . For a subset  $O \subset G$ , let  $R$  be minimal such that  $O$  is contained in  $B_R(v)$  for some  $v \in G$ . The quasi-centre of  $O$  is the set of all  $v \in G$  with  $O \subset B_R(v)$ . By Bridson and Haefliger [3, Lemma III.Γ.3.3], the diameter of the quasi-centre of any finite subset of  $G$  is at most  $4\delta + 1$ .

Let  $C \subset G$  be the quasi-centre of the orbit  $HS$ . For any  $r \in \mathbb{N}$ , the ball  $B_r(C)$  is  $H$ -invariant, and for  $r$  large enough, we have  $S \subset B_r(C)$ . Thus to prove the lemma, it suffices to show that for any  $r \in \mathbb{N}$ , the graph induced on  $B_r(C)$  in the 1-skeleton of  $P_D(G)$  is dismantlable. If  $r < 2\delta$ , then  $B_r(C)$  spans a simplex in  $P_D(G)$  and the assertion is clear. Thus it remains to prove the following claim. We denote the distance in the Cayley graph by  $d(\cdot, \cdot)$ .

**Claim** Consider a vertex  $v \in G$  at distance  $a \geq 2\delta$  from  $C$ . Let  $w \in C$  be at distance  $a$  from  $v$ . Let  $u \in G$  be a vertex lying on a geodesic  $vw$  with  $d(u, v) = 2\delta$ . Then  $u$  dominates  $v$  in the subgraph of the 1-skeleton of  $P_D(G)$  induced on  $B_a(C)$ .

**Proof of Claim** The proof is similar to the proof of [3, Proposition III.Γ.3.23]. Let  $t \in B_a(C)$  be such that  $d(t, v) \leq D$ , ie,  $t$  is a neighbour of  $v$  in  $P_D(G)$ . We have to show that  $d(t, u) \leq D$ . Consider geodesics  $wt$  and  $tv$ . By  $\delta$ -hyperbolicity, we have  $d(u, u') \leq \delta$  for some vertex  $u' \in wt \cup tv$ . There are two cases:

**Case 1**  $u' \in wt$ . In this case we have

$$\begin{aligned} d(t, u') + d(u', w) &= d(t, w) \leq \text{diam}(C) + a = \text{diam}(C) + d(v, u) + d(u, w) \\ &\leq \text{diam}(C) + d(v, u) + d(u, u') + d(u', w) \\ &\leq \text{diam}(C) + d(v, u) + \delta + d(u', w). \end{aligned}$$

Hence  $d(t, u') \leq d(u, v) + \text{diam}(C) + \delta$ , and it follows that

$$d(t, u) \leq d(t, u') + d(u', u) \leq d(u, v) + \text{diam}(C) + 2\delta \leq 8\delta + 1 \leq D.$$

**Case 2**  $u' \in tv$ . Since  $d(v, u') \geq d(v, u) - d(u, u') \geq 2\delta - \delta = \delta$ , we have  $d(t, u') = d(t, v) - d(v, u') \leq D - \delta$ . It follows that  $d(t, u) \leq d(t, u') + d(u', u) \leq (D - \delta) + \delta = D$ . In both cases we obtain the desired inequality. □

## References

- [1] **J A Barmak, E G Minian**, *Strong homotopy types, nerves and collapses*, Discrete Comput. Geom. 47 (2012) 301–328 [MR2872540](#)
- [2] **B H Bowditch, D B A Epstein**, *Natural triangulations associated to a surface*, Topology 27 (1988) 91–117 [MR935529](#)
- [3] **M R Bridson, A Haefliger**, *Metric spaces of non-positive curvature*, Grundle. Math. Wissen. 319, Springer, Berlin (1999) [MR1744486](#)
- [4] **P Buser**, *Geometry and spectra of compact Riemann surfaces*, Modern Birkhäuser Classics, Birkhäuser, Boston (2010) [MR2742784](#)
- [5] **V Chepoi, D Osajda**, *Dismantlability of weakly systolic complexes and applications*, to appear in Trans. Amer. Math. Soc. (2014) [arXiv:0910.5444v1](#)
- [6] **M Culler**, *Finite groups of outer automorphisms of a free group*, from: “Contributions to group theory”, (K I Appel, J G Ratcliffe, P E Schupp, editors), Contemp. Math. 33, Amer. Math. Soc. (1984) 197–207 [MR767107](#)
- [7] **B Farb, D Margalit**, *A primer on mapping class groups*, Princeton Mathematical Series 49, Princeton Univ. Press (2012) [MR2850125](#)
- [8] **D Gabai**, *Convergence groups are Fuchsian groups*, Ann. of Math. 136 (1992) 447–510 [MR1189862](#)
- [9] **U Hamenstädt, S Hensel**, *The geometry of the handlebody groups I: Distortion*, J. Topol. Anal. 4 (2012) 71–97 [MR2914874](#)
- [10] **U Hamenstädt, S Hensel**, *Sphere systems, intersections and the geometry of  $\text{Out}(F_n)$*  (2014) [arXiv:1109.2687v3](#)
- [11] **J L Harer**, *Stability of the homology of the mapping class groups of orientable surfaces*, Ann. of Math. 121 (1985) 215–249 [MR786348](#)
- [12] **J L Harer**, *The virtual cohomological dimension of the mapping class group of an orientable surface*, Invent. Math. 84 (1986) 157–176 [MR830043](#)
- [13] **A Hatcher**, *On triangulations of surfaces*, Topology Appl. 40 (1991) 189–194 [MR1123262](#)
- [14] **A Hatcher**, *Homological stability for automorphism groups of free groups*, Comment. Math. Helv. 70 (1995) 39–62 [MR1314940](#)
- [15] **L Ji, S A Wolpert**, *A cofinite universal space for proper actions for mapping class groups*, from: “In the tradition of Ahlfors–Bers, V”, (M Bonk, J Gilman, H Masur, Y Minsky, M Wolf, editors), Contemp. Math. 510, Amer. Math. Soc. (2010) 151–163 [MR2581835](#)
- [16] **R P Kent, IV, C J Leininger, S Schleimer**, *Trees and mapping class groups*, J. Reine Angew. Math. 637 (2009) 1–21 [MR2599078](#)

- [17] **SP Kerckhoff**, *The Nielsen realization problem*, Bull. Amer. Math. Soc. 2 (1980) 452–454 [MR561531](#)
- [18] **SP Kerckhoff**, *The Nielsen realization problem*, Ann. of Math. 117 (1983) 235–265 [MR690845](#)
- [19] **DG Khramtsov**, *Finite groups of automorphisms of free groups*, Mat. Zametki 38 (1985) 386–392, 476 [MR811572](#)
- [20] **S Krstić, K Vogtmann**, *Equivariant outer space and automorphisms of free-by-finite groups*, Comment. Math. Helv. 68 (1993) 216–262 [MR1214230](#)
- [21] **F Laudenbach**, *Topologie de la dimension trois: Homotopie et isotopie*, Astérisque 12, Société Mathématique de France, Paris (1974) [MR0356056](#)
- [22] **H Masur**, *Measured foliations and handlebodies*, Ergodic Theory Dynam. Systems 6 (1986) 99–116 [MR837978](#)
- [23] **D McCullough**, *Virtually geometrically finite mapping class groups of 3-manifolds*, J. Differential Geom. 33 (1991) 1–65 [MR1085134](#)
- [24] **D Meintrup, T Schick**, *A model for the universal space for proper actions of a hyperbolic group*, New York J. Math. 8 (2002) 1–7 [MR1887695](#)
- [25] **G Mislin**, *Classifying spaces for proper actions of mapping class groups*, Münster J. Math. 3 (2010) 263–272 [MR2775365](#)
- [26] **J Nielsen**, *Abbildungsklassen endlicher Ordnung*, Acta Math. 75 (1943) 23–115 [MR0013306](#)
- [27] **RC Penner**, *The decorated Teichmüller space of punctured surfaces*, Comm. Math. Phys. 113 (1987) 299–339 [MR919235](#)
- [28] **N Polat**, *Finite invariant simplices in infinite graphs*, Period. Math. Hungar. 27 (1993) 125–136 [MR1291160](#)
- [29] **P Przytycki, J Schultens**, *Contractibility of the Kakimizu complex and symmetric Seifert surfaces*, Trans. Amer. Math. Soc. 364 (2012) 1489–1508 [MR2869183](#)
- [30] **S Schleimer**, *Notes on the complex of curves* (2005) Available at <http://www.warwick.ac.uk/~masgar/math.html>
- [31] **P Tukia**, *Homeomorphic conjugates of Fuchsian groups*, J. Reine Angew. Math. 391 (1988) 1–54 [MR961162](#)
- [32] **T White**, *Fixed points of finite groups of free group automorphisms*, Proc. Amer. Math. Soc. 118 (1993) 681–688 [MR1164152](#)
- [33] **SA Wolpert**, *Geodesic length functions and the Nielsen problem*, J. Differential Geom. 25 (1987) 275–296 [MR880186](#)
- [34] **H Zieschang**, *Finite groups of mapping classes of surfaces*, Lecture Notes in Mathematics 875, Springer, Berlin (1981) [MR643627](#)

- [35] **B Zimmermann**, *Über Abbildungsklassen von Henkelkörpern*, Arch. Math. (Basel) 33 (1979/80) 379–382 MR564296
- [36] **B Zimmermann**, *Über Homöomorphismen  $n$ -dimensionaler Henkelkörper und endliche Erweiterungen von Schottky-Gruppen*, Comment. Math. Helv. 56 (1981) 474–486 MR639363

SH: Department of Mathematics, University of Chicago  
5734 S University Ave., Chicago, IL 60637, USA

DO: Instytut Matematyczny, Uniwersytet Wrocławski  
pl. Grunwaldzki 2/4, 50-384 Wrocław, Poland  
and

Universität Wien, Fakultät für Mathematik  
Oskar-Morgenstern-Platz 1, 1090 Wien, Austria

PP: McGill University, The Department of Mathematics and Statistics  
Burnside Hall, Room 1005, 805 Sherbrooke Street West, Montreal, QC, H3A 0B9, Canada  
and

Institute of Mathematics, Polish Academy of Sciences  
Śniadeckich 8, 00-656 Warsaw, Poland

[hensel@uchicago.edu](mailto:hensel@uchicago.edu), [dosaj@math.uni.wroc.pl](mailto:dosaj@math.uni.wroc.pl), [pprzytyc@mimuw.edu.pl](mailto:pprzytyc@mimuw.edu.pl)

Proposed: Martin R Bridson  
Seconded: Danny Calegari, Benson Farb

Received: 19 June 2012  
Accepted: 11 January 2014