



Geometry & Topology

Volume 29 (2025)

Embedded contact homology and open book decompositions

VINCENT COLIN

PAOLO GHIGGINI

KO HONDA

APPENDIX WRITTEN JOINTLY WITH YUAN YAO

Embedded contact homology and open book decompositions

VINCENT COLIN

PAOLO GHIGGINI

KO HONDA

APPENDIX WRITTEN JOINTLY WITH YUAN YAO

Given a closed oriented contact 3-manifold M , we prove an equivalence between the embedded contact homology of M and a version of embedded contact homology “relative to the boundary”, defined on the complement of a tubular neighborhood of a null-homologous knot. This paper can be viewed as the first of a series of papers devoted to proving the isomorphism between Heegaard Floer homology and embedded contact homology.

The appendix, written jointly with Yuan Yao, gives a complete proof of Morse–Bott gluing for one-level cascades in embedded contact homology.

57K31, 57K33

1. Introduction	3346
2. Review of embedded contact homology	3348
3. Cobordism maps and direct limits	3354
4. Morse–Bott theory	3359
5. Topological constraints on holomorphic curves	3370
6. Construction of contact forms	3375
7. ECH for manifolds with torus boundary	3378
8. ECH of the solid torus	3388
9. Proof of Theorem 1.1.1	3400
10. Applications to sutured ECH	3420
Appendix. Morse–Bott gluing	3427
References	3460

1 Introduction

Let M be a closed, oriented, connected 3-manifold and $N \subset M$ the complement of a tubular neighborhood of a null-homologous knot. The goal of this paper is to associate a specific class of contact forms α to N , to introduce relative embedded contact homology groups $\text{ECH}(N, \partial N, \alpha)$ and $\widehat{\text{ECH}}(N, \partial N, \alpha)$, and to prove their isomorphism with the embedded contact homology groups $\text{ECH}(M)$ and $\widehat{\text{ECH}}(M)$.

The embedded contact homology group $\text{ECH}(M)$ of a closed 3-manifold M , due to Hutchings [2002] partially in collaboration with Taubes [Hutchings and Taubes 2007; 2009a], is defined using a contact form α on M and an adapted almost complex structure J on the symplectization $\mathbb{R} \times M$. The variant $\widehat{\text{ECH}}(M)$, called *ECH hat*, is defined as the mapping cone of a U -map (see Section 2.5). There is currently no direct proof of the fact that these groups are invariants of M ; the only known proof, due to Taubes [2007; 2010], is a consequence of the isomorphism between Seiberg–Witten Floer cohomology and embedded contact homology, combined with the invariance of Seiberg–Witten Floer cohomology established by Kronheimer and Mrowka [2007].

Embedded contact homology groups can be defined over the integers, following [Bourgeois and Mohnke 2004] or [Hutchings and Taubes 2009a, Section 9]. All results in this article hold over the integers as explained in Proposition 4.5.5 and Remark 9.9.5, but we will write detailed proofs only over the field $\mathbb{F} = \mathbb{Z}/2\mathbb{Z}$ for simplicity. Given a compact 3-manifold N with $\partial N \simeq T^2$, let α be a contact form on N which is nondegenerate on $\text{int}(N)$ and negative Morse–Bott on ∂N (see Definition 4.1.1). In particular, the Reeb orbits on ∂N act as sinks for J -holomorphic curves in $\mathbb{R} \times N$, ie no nontrivial J -holomorphic curve in $\mathbb{R} \times N$ can have a positive end at an orbit in ∂N . Then there exist relative embedded contact homology groups $\text{ECH}(N, \partial N, \alpha)$ and $\widehat{\text{ECH}}(N, \partial N, \alpha)$, whose definitions will be given in Section 7. Moreover, there is a chain map U on the complex defining $\text{ECH}(N, \partial N, \alpha)$, and the homology of the cone of U is isomorphic to $\widehat{\text{ECH}}(N, \partial N, \alpha)$.

The embedded contact homology group of a contact manifold (M, ξ) has a natural decomposition as a direct sum of groups $\text{ECH}(M, \xi, A)$ indexed by homology classes¹ $A \in H_1(M)$. This decomposition depends on the contact structure ξ , although very weakly. For this reason we always specify ξ together with the homology class A .

Similarly, $\text{ECH}(N, \partial N, \alpha)$ and $\widehat{\text{ECH}}(N, \partial N, \alpha)$ decompose as direct sums of groups $\text{ECH}(N, \partial N, \alpha, A)$ and $\widehat{\text{ECH}}(N, \partial N, \alpha, A)$ indexed by relative homology classes $A \in H_1(N, \partial N)$. The maps U in both $\text{ECH}(M, \xi)$ and $\text{ECH}(N, \partial N, \alpha)$ preserve the splitting according to homology classes. Taking into account the fact that K is null-homologous, excision and the relative homology long exact sequence give an isomorphism $\varpi : H_1(N, \partial N) \xrightarrow{\cong} H_1(M)$, and the equivalence between ECH and relative ECH is compatible with the corresponding decompositions.

The main result of this paper is the following:

¹Singular homology groups should always be understood over the integers if no coefficient group is explicitly indicated.

Theorem 1.1.1 *Let $N \subset M$ be the complement of a tubular neighborhood $\text{int}(V)$ of a null-homologous knot K , where $V \simeq K \times D^2$, ξ a contact form on M which is transverse to the foliation $K \times \{*\}$ on V , and α a contact form on N for the contact structure $\xi|_N$. If the Reeb vector field R_α of α is nondegenerate on $\text{int}(N)$, negative Morse–Bott on ∂N and foliates ∂N by meridians, and all closed Reeb orbits in N have nonnegative linking number with K , then, for all $A \in H_1(N, \partial N; \mathbb{Z})$,*

- (1) $\text{ECH}(N, \partial N, \alpha, A) \simeq \text{ECH}(M, \xi, \varpi(A))$, and
- (2) $\widehat{\text{ECH}}(N, \partial N, \alpha, A) \simeq \widehat{\text{ECH}}(M, \xi, \varpi(A))$.

Moreover, the first isomorphism is compatible with the U -maps on both sides.

The prototypical situation to which Theorem 1.1.1 applies is the case of an open book decomposition with connected binding. In this case N is the mapping torus of a surface diffeomorphism $h: S \xrightarrow{\cong} S$ and $V = M - \text{int}(N)$ is a tubular neighborhood of the binding. In other words, Theorem 1.1.1 allows us to rewrite the embedded contact homology groups of M in terms of the relative embedded contact homology groups on the complement of the binding. We remark here that [Yau 2007; Wendl 2008; 2005] examined related issues.

Theorem 1.1.1, applied to the open book case, is the first step in the proof of the equivalence of embedded contact homology and Heegaard Floer homology, a Floer homology theory for three-manifolds defined by Ozsváth and Szabó [2004a; 2004b]. Once we express the embedded contact homology of M purely in terms of N using Theorem 1.1.1, it is easier to define chain maps to and from the hat version of Heegaard Floer homology. In fact, the Giroux correspondence [2002] — the bijection between open book decompositions up to positive stabilization and isotopy classes of contact structures — provides a bridge between the contact forms used in the definition of ECH and the Heegaard splittings used in the definition of Heegaard Floer homology. We remark that the proof of the equivalence between Heegaard Floer homology and ECH is independent of the hard part of the Giroux correspondence (ie the stabilization equivalence of two open book decompositions which support the same contact structure). The rest of the proof of the equivalence has been carried out in [Colin et al. 2024a; 2024b; 2024c]; see [Colin et al. 2011a] for an overview of the strategy.

Remark 1.1.2 An alternative proof of the equivalence of Heegaard Floer and embedded contact homologies, passing through Seiberg–Witten Floer homology, has been given by Kutluhan, Lee and Taubes [Kutluhan et al. 2020a; 2020b; 2020c; 2020d; 2020e].

In Section 10 we present some independent applications of the techniques developed here to the embedded contact homology for sutured manifolds defined in [Colin et al. 2011b]. More precisely, we prove that ECH of a sutured manifold is invariant of the contact form and the almost complex structure (Theorem 10.2.2) and we finish the proof of [Colin et al. 2011b, Theorem 1.6] by showing that $\widehat{\text{ECH}}(M)$, defined as the homology of the cone of the U -map, is isomorphic to the sutured ECH of the complement of a ball

in M (Theorem 10.3.1). Theorem 10.2.2 has been independently proved by Kutluhan, Sivek and Taubes [Kutluhan et al. 2022].

Organization of the paper Section 2 gives a brief review of ECH; in particular, we define the groups $\text{ECH}(M)$ and $\widehat{\text{ECH}}(M)$. We review some technicalities involving direct limits in Section 3 and some Morse–Bott theory in the context of ECH in Section 4. In Section 5 we discuss topological constraints of J -holomorphic curves arising from the positivity of intersections in dimension four. In Section 6 we construct contact forms on $D^2 \times S^1$ and $T^2 \times [1, 2]$ which are used later. Section 7 is devoted to the definitions of certain ECH groups for compact manifolds with torus boundary and in particular the variants $\text{ECH}(N, \partial N, \alpha)$ and $\widehat{\text{ECH}}(N, \partial N, \alpha)$ which appear in Theorem 1.1.1. In Section 8 we calculate some ECH groups of solid tori which are used in the proof of Theorem 1.1.1. Section 9 then completes the proof of Theorem 1.1.1. Finally, Section 10 relates some of the versions of ECH defined in Section 7 to some sutured ECH groups defined in [Colin et al. 2011b].

2 Review of embedded contact homology

In this paper all manifolds will be oriented and connected, unless stated otherwise.

In this section we briefly review the basic definitions of embedded contact homology (from now on abbreviated ECH). For more details the reader is referred to [Hutchings 2002; 2009] or to [Hutchings 2014]. To avoid orienting the moduli spaces, we will work over $\mathbb{F} = \mathbb{Z}/2\mathbb{Z}$.

2.1 Generators of the ECH chain complex

Let M be a closed, oriented and connected 3-manifold with a contact form α . We will denote by $\xi = \ker \alpha$ the contact structure with contact form α . The Reeb vector field $R = R_\alpha$ is *nondegenerate* if no Reeb orbit² has 1 as eigenvalue of its linearized first return map. This is a generic condition which can be achieved by a generic C^∞ -small perturbation of the contact form; see for example [Colin and Honda 2013, Lemma 7.1]. For the rest of the section we will assume that α is nondegenerate. The linearization of the first return map along a Reeb orbit is a symplectic transformation of the symplectic plane $(\xi, d\alpha)$. This implies that its eigenvalues are $\{\lambda, \lambda^{-1}\}$, where λ is either real or in the unit circle. Then a Reeb orbit is

- *hyperbolic* if the eigenvalues of its linearized first return map are real; or
- *elliptic* if they lie on the unit circle.

These conditions are mutually exclusive because every orbit is assumed to be nondegenerate.

²In this paper we interchangeably use “Reeb orbit”, “closed orbit” and “closed Reeb orbit”. A Reeb orbit which is not necessarily closed will be called a “Reeb trajectory”.

Let \mathcal{P} be the set of simple orbits of the Reeb vector field R_α . The ECH chain complex³ $\text{ECC}(M, \alpha)$, as a vector space, is generated over \mathbb{F} by finite sets $\gamma = \{(\gamma_i, m_i)\}$, called *orbit sets*, where

- $\gamma_i \in \mathcal{P}$ and $\gamma_i \neq \gamma_j$ for $i \neq j$;
- m_i is a positive integer; and
- if γ_i is a hyperbolic orbit, then $m_i = 1$.

We will say that $\text{ECC}(M, \alpha)$ is *constructed from* \mathcal{P} . An orbit set γ will also be written multiplicatively as $\prod \gamma_i^{m_i}$, with the convention that $\gamma_i^2 = 0$ whenever γ_i is hyperbolic. The empty orbit set \emptyset will be written multiplicatively as 1.

The homology class of an orbit set γ is

$$[\gamma] = \sum_i m_i [\gamma_i] \in H_1(M).$$

If we want to specify the direct summand generated by orbit sets of class $A \in H_1(M)$, then we write $\text{ECC}(M, \alpha, A)$.

The *action* $\mathcal{A}_\alpha(\gamma_i)$ of an orbit γ_i is given by $\int_{\gamma_i} \alpha$, and the action of an orbit set γ is given by

$$\mathcal{A}_\alpha(\gamma) = \sum_i m_i \mathcal{A}_\alpha(\gamma_i).$$

2.2 Moduli spaces

We choose an almost complex structure J on $\mathbb{R} \times M$, with \mathbb{R} -coordinate s , which is *adapted to the symplectization of α* (or *adapted to α*), ie

- (i) J is s -invariant;
- (ii) J takes ξ to itself on each $\{s\} \times Y$;
- (iii) J maps ∂_s to R_α ;
- (iv) $J|_\xi$ is $d\alpha$ -compatible, ie $d\alpha(\cdot, J\cdot)$ defines a Euclidean metric on ξ .

Let $\gamma = \{(\gamma_i, m_i)\}$ and $\gamma' = \{(\gamma'_i, m'_i)\}$ be orbit sets with $[\gamma] = [\gamma'] \in H_1(M)$. We denote by $\mathcal{M}_J(\gamma, \gamma')$ the set of holomorphic maps

$$u: (F, j) \rightarrow (\mathbb{R} \times M, J),$$

modulo holomorphic reparametrizations, which satisfy

- (1) (F, j) is a closed Riemann surface with a finite number of punctures removed;
- (2) the neighborhoods of the punctures are mapped asymptotically to cylinders over Reeb orbits;

³The ECH differential depends on the choice of an adapted almost complex structure J (see Section 2.2), but the generators only depend on α . Hence we suppress J from the notation for the moment.

- (3) at the positive end of $\mathbb{R} \times M$, u is asymptotic to $\mathbb{R} \times \gamma_i$ with total multiplicity m_i for each pair (γ_i, m_i) (more precisely, if we list the positive ends of u that are asymptotic to some multiple cover of $\mathbb{R} \times \gamma_i$ and the covering degrees are m_{i1}, \dots, m_{ij_i} , then $m_i = m_{i1} + \dots + m_{ij_i}$); and
- (4) at the negative end of $\mathbb{R} \times M$, u is asymptotic to $\mathbb{R} \times \gamma'_i$ with total multiplicity m'_i for each pair (γ'_i, m'_i) .

We often refer to an element u of $\mathcal{M}_J(\gamma, \gamma')$ as a J -holomorphic map (or curve) from γ to γ' . We stress that, according to our definition, the genus, the number of connected components and the number of punctures of F are not fixed a priori. If $*$ is a property of J -holomorphic curves, we will denote by $\mathcal{M}_J^*(\gamma, \gamma')$ the subset of $\mathcal{M}_J(\gamma, \gamma')$ satisfying $*$. We can similarly define the “pointed” moduli space $\mathcal{M}_J(\gamma, \gamma'; \text{pt})$ as the set of holomorphic maps

$$u: (F, j, p) \rightarrow (\mathbb{R} \times M, J),$$

modulo holomorphic reparametrizations, where $p \in F$.

Definition 2.2.1 We say that J is *regular* if, for all orbit sets γ and γ' and $u \in \mathcal{M}_J(\gamma, \gamma')$ which has no multiply covered components, $\mathcal{M}_J(\gamma, \gamma')$ is transversely cut out near u (ie the linearized $\bar{\partial}$ -operator D_u at u from [Dragnev 2004, Proposition 2.10] is surjective).

Regular adapted almost complex structures form the complement of a first category set (and therefore are dense) in the space of smooth adapted almost complex structures with respect to the C^∞ -topology by a result of Dragnev [2004]. If no component of u is multiply covered and all components of u are transversely cut out, then, in a neighborhood of u , the moduli space $\mathcal{M}_J(\gamma, \gamma')$ has the structure of a finite-dimensional manifold of dimension $\text{ind}(u)$, where the Fredholm index $\text{ind}(u)$ is the formal dimension of the moduli spaces computed as in the next paragraph; see [Dragnev 2004, Corollary 1]. Our convention throughout the paper will be that the Fredholm index takes into account the dimensions of the Deligne–Mumford moduli space and the automorphism group of the domain of the map. In particular, $\text{ind}(u) = \text{ind}(D_u) - 3\chi(F)$, where $\text{ind}(D_u)$ is the Fredholm index of the linearized Cauchy–Riemann operator at u and $\chi(F)$ is the Euler characteristic of the domain of u .

A J -holomorphic map $u: F \rightarrow \mathbb{R} \times M$ from $\gamma = \{(\gamma_i, m_i)\}$ to $\gamma' = \{(\gamma'_i, m'_i)\}$ determines partitions $\{m_{ij}\}$ of m_i and $\{m'_{ij}\}$ of m'_i such that u is positively asymptotic to m_{ij} -fold covers $\gamma_i^{m_{ij}}$ of the simple Reeb orbits γ_i and negatively asymptotic to m'_{ij} -fold covers $(\gamma'_i)^{m'_{ij}}$ of the simple Reeb orbits γ'_i . Let τ be a trivialization of ξ along each orbit in the orbit sets γ, γ' , let $\mu_\tau(\delta)$ denote the Conley–Zehnder index of a cover δ of an orbit in γ or γ' with respect to τ , and let $c_1(u^*\xi, \tau)$ denote the relative first Chern class of $u^*\xi$ with respect to τ . Then the Fredholm index $\text{ind}(u)$ is given by the formula

$$(2-2-1) \quad \text{ind}(u) = -\chi(F) + 2c_1(u^*\xi, \tau) + \sum_{ij} \mu_\tau(\gamma_i^{m_{ij}}) - \sum_{ij} \mu_\tau((\gamma'_i)^{m'_{ij}}).$$

(See the formula in [Dragnev 2004, Theorem 1.8].)

2.3 The ECH index

The index which appears in the definition of ECH is not the Fredholm index, but the ECH index, which is more topological in nature. In this subsection we will review its definition.

Let $\gamma = \{(\gamma_i, m_i)\}$ and $\gamma' = \{(\gamma'_i, m'_i)\}$ be orbit sets. We denote by $H_2(M, \gamma, \gamma')$ the relative homology classes of surfaces $Z \in H_2(M, (\bigcup_i \gamma_i) \cup (\bigcup_{i'} \gamma_{i'}))$ such that $\partial Z = \sum m_i [\gamma_i] - \sum m'_i [\gamma'_i]$, where

$$\partial: H_2\left(M, \left(\bigcup_i \gamma_i\right) \cup \left(\bigcup_{i'} \gamma_{i'}\right)\right) \rightarrow H_1\left(\left(\bigcup_i \gamma_i\right) \cup \left(\bigcup_{i'} \gamma_{i'}\right)\right)$$

is the connecting homomorphism of the relative homology exact sequence. By abuse of notation, Z will also denote an embedded surface with boundary which represents that homology class. We pick a trivialization τ of ξ along each orbit in the orbit sets γ and γ' , and define $c_1(\xi|_Z, \tau)$ as the first Chern class of ξ evaluated on Z , relative to the trivialization τ on ∂Z .

If $\gamma = \{(\gamma_i, m_i)\}_{i=1}^k$ is an orbit set, then we define the “symmetric” Conley–Zehnder index (so called because of its motivation from studying symplectomorphisms of a symmetric product of a surface) as

$$(2-3-1) \quad \tilde{\mu}_\tau(\gamma) = \sum_{i=1}^k \sum_{j=1}^{m_i} \mu_\tau(\gamma_i^j),$$

where γ_i^j is the orbit which multiply covers γ_i with multiplicity j .

We define the *relative intersection pairing* $Q_\tau(Z)$ as follows: Using the trivialization τ , for each simple orbit γ_i of γ or γ' , fix an identification of a sufficiently small neighborhood $N(\gamma_i)$ of γ_i with $\gamma_i \times D^2$, where D^2 has polar coordinates (r, θ) . Let Σ be an oriented surface and $f: \Sigma \rightarrow [-1, 1] \times M$ a smooth map which satisfies the following:

- (1) f maps $\partial\Sigma$ to $\{-1, 1\} \times M$, $f|_{\text{int}(\Sigma)}$ is an embedding, and f is transverse to $\{-1, 1\} \times M$.
- (2) For all $\varepsilon > 0$ sufficiently small, $f(\Sigma) \cap (\{1 - \varepsilon\} \times M)$ consists of m_i disjoint circles of type $\{r = \varepsilon, \theta = \text{const}\}$ in $N(\gamma_i)$ for all i (and similarly for $f(\Sigma) \cap (\{-1 + \varepsilon\} \times M)$).
- (3) The composition of f with the projection $[-1, 1] \times M \rightarrow M$ is a representative of the class $Z \in H_2(M, \gamma, \gamma')$.

We then choose two maps f_1 and f_2 satisfying (1)–(3) above that are disjoint on $\{-1 + \varepsilon, 1 - \varepsilon\} \times M$ and transverse on $[-1 + \varepsilon, 1 - \varepsilon] \times M$. Then $Q_\tau(Z)$ is the signed intersection number of f_1 and f_2 in $[-1 + \varepsilon, 1 - \varepsilon] \times M$.

We are now in a position to define the ECH index.

Definition 2.3.1 [Hutchings 2002, Definition 1.5] The ECH index $I(\gamma, \gamma', Z)$ is given by

$$(2-3-2) \quad I(\gamma, \gamma', Z) = c_1(\xi|_Z, \tau) + Q_\tau(Z) + \tilde{\mu}_\tau(\gamma) - \tilde{\mu}_\tau(\gamma').$$

The ECH index depends only on the relative homology class $Z \in H_2(M, \gamma, \gamma')$ and not on a particular surface representing it. Moreover, the ECH index is independent also of the choice of trivialization. If

$Z' \in H_2(M, \gamma, \gamma')$ is another relative homology class, then, by [Hutchings 2014],

$$I(\gamma, \gamma', Z') - I(\gamma, \gamma', Z) = \left\langle Z' - Z, c_1(\xi) + \text{PD} \left(\sum_i m_i [\gamma_i] \right) \right\rangle,$$

where $\sum_i m_i [\gamma_i]$ is the total homology class of γ in $H_1(M)$ and PD is the Poincaré duality map.

Remark 2.3.2 A finite-energy holomorphic map u with asymptotics γ and γ' defines a relative homology class $Z \in H_2(M, \gamma, \gamma')$. Hence we can write $I(u) = I(\gamma, \gamma', Z)$.

The ECH index and the Fredholm index satisfy the following index inequality, which is one of the basic tools of ECH:

Theorem 2.3.3 [Hutchings 2009, Theorem 4.15] *If u is simply covered, then $\text{ind}(u) \leq I(u)$.*

2.4 The ECH differential

In this subsection we define the differential ∂ for the ECH chain complex, after recalling some properties of J -holomorphic maps with small ECH index. In the following we will say that a map $u: F \rightarrow \mathbb{R} \times M$ is the “disjoint union” of maps $u_i: F_i \rightarrow \mathbb{R} \times M$ (with $1 \leq i \leq k$) if $F = F_1 \sqcup \cdots \sqcup F_k$ and the images are pairwise disjoint. Here each F_i can still be disconnected. A *trivial cylinder* over a (not necessarily simple) orbit γ with period T is the J -holomorphic map $u: \mathbb{R} \times S^2 \rightarrow \mathbb{R} \times M$, $u(s, t) = (Ts, \gamma(Tt))$. By abuse of notation, we will always denote the trivial cylinder over γ by $\mathbb{R} \times \gamma$.

Lemma 2.4.1 [Hutchings and Taubes 2007, Proposition 7.15] *Let J be a regular almost complex structure adapted to α . Then:*

- (1) *A J -holomorphic map u with $I(u) = 0$ is a disjoint union of branched covers of trivial cylinders over simple Reeb orbits. (Such curves are called *connectors*.)*
- (2) *A J -holomorphic map u with $I(u) = 1$ (resp. 2) from γ to γ' is a disjoint union of a connector and an embedding u' with $I(u') = \text{ind}(u') = 1$ (resp. 2).*

In this paper a “branched cover” will always refer to a “branched cover with possibly empty branch locus”.

The ends of a J -holomorphic map u from γ to γ' determine partitions of the multiplicities of the elliptic orbits. It turns out that, when $I(u) = 1$ or $I(u) = 2$, these partitions must coincide with preferred partitions, called the *outgoing* and *incoming* partitions for positive and negative ends, respectively. The incoming and outgoing partitions can be computed from the dynamics of the linearized Reeb flow. For their definition see [Hutchings 2002, Section 4.1] or [Hutchings 2009, Definition 4.14]. For the relation between these partitions and the ECH index, see [Hutchings 2009, Theorem 4.15], for example. In this article we will not need the precise definition of the incoming or the outgoing partition, except for the following fact, which follows directly from [Hutchings 2009, Definition 4.14]:

Fact 2.4.2 Let γ be a simple elliptic orbit and suppose that its linearized Reeb flow rotates by an angle $2\pi\theta$. If $0 < \theta < 1/m$, then the incoming partition of (γ, m) is (m) and the outgoing partition is $(1, \dots, 1)$. On the other hand, if $-1/m < \theta < 0$, then the incoming partition of (γ, m) is $(1, \dots, 1)$ and the outgoing partition is (m) .

The boundary operator in the ECH chain complex is defined by a count of J -holomorphic maps with index $I = 1$ for a regular almost complex structure J . In order to make the dependence on J explicit, we write the complex as $\text{ECC}(M, \alpha, J)$. However, when J is clear from the context, it will be dropped from the notation.

Definition 2.4.3 Let J be a regular almost complex structure adapted to α . Then the boundary map $\partial: \text{ECC}(M, \alpha, J) \rightarrow \text{ECC}(M, \alpha, J)$ is defined as

$$\partial\gamma = \sum_{\gamma'} \langle \partial\gamma, \gamma' \rangle \gamma',$$

where $\langle \partial\gamma, \gamma' \rangle$ is the (mod 2) count of curves $u \in \mathcal{M}_J^{I=1}(\gamma, \gamma')/\mathbb{R}$ such that every connector component of u is a trivial cylinder over a simple orbit.

The map ∂ was shown to satisfy $\partial^2 = 0$ by Hutchings and Taubes [2007; 2009a]. The homology of the chain complex $(\text{ECC}(M, \alpha, J), \partial)$ is the *embedded contact homology* group $\text{ECH}(M, \alpha, J)$. It is independent of the choice of contact form α , the contact structure ξ and adapted almost complex structure J by [Taubes 2010]. Hence we are justified in writing $\text{ECH}(M)$.

2.5 Definition of $\widehat{\text{ECH}}(M)$

In this subsection we define a map $U: \text{ECH}(M) \rightarrow \text{ECH}(M)$ and a variant $\widehat{\text{ECH}}(M)$ of $\text{ECH}(M)$, called the *ECH hat group*, in analogy with well-known constructions in Heegaard Floer homology. An a priori different group, also called $\widehat{\text{ECH}}(M)$, was defined in [Colin et al. 2011b] using sutured ECH (in analogy with the sutured Floer homology of [Juhász 2006]). In Section 10 we will prove that the two approaches yield isomorphic groups.

Definition 2.5.1 Let J be a regular almost complex structure and $z \in \mathbb{R} \times M$ a generic point such that the evaluation map

$$\text{ev}: \mathcal{M}_J^{I=2}(\gamma, \gamma'; \text{pt}) \rightarrow \mathbb{R} \times M, \quad (u, p) \mapsto u(p),$$

is transverse to z . We define the map $U: \text{ECC}(M, \alpha, J) \rightarrow \text{ECC}(M, \alpha, J)$ as

$$U\gamma = \sum_{\gamma'} \langle U\gamma, \gamma' \rangle \gamma',$$

where $\langle U\gamma, \gamma' \rangle$ is the (mod 2) count of elements of $\text{ev}^{-1}(z) \subset \mathcal{M}_J^{I=2}(\gamma, \gamma'; \text{pt})$ such that every connector component of u is a trivial cylinder over a simple Reeb orbit.

The same techniques used to show that $\partial^2 = 0$ also show that U is a chain map; see [Hutchings and Taubes 2009b, Section 2.5] for more details on the U -map. Then $\widehat{\text{ECH}}(M, \alpha, J)$ is defined as the homology of the mapping cone of U .

3 Cobordism maps and direct limits

In this section we review the work of Hutchings and Taubes [2011] on maps on ECH induced by exact symplectic cobordisms, which in turn makes it possible to define continuation maps and take direct limits in ECH.

3.1 Maps induced by cobordisms

Given a contact 3-manifold (M, α) with α nondegenerate, let $\text{ECC}^L(M, \alpha)$ be the subcomplex of $\text{ECC}(M, \alpha)$ generated by orbit sets γ of action $\mathcal{A}_\alpha(\gamma) < L$, and $\text{ECH}^L(M, \alpha)$ be the resulting homology group. Given $L < L'$, the inclusion of chain complexes $\text{ECC}^L(M, \alpha) \subset \text{ECC}^{L'}(M, \alpha)$ induces a map

$$i_{L,L'}: \text{ECH}^L(M, \alpha) \rightarrow \text{ECH}^{L'}(M, \alpha)$$

on the level of homology. An immediate consequence of the definition of a direct limit is

$$\text{ECH}(M, \alpha) = \lim_{L \rightarrow \infty} \text{ECH}^L(M, \alpha).$$

Let (M_1, α_1) and (M_2, α_2) be contact 3-manifolds. An *exact symplectic cobordism* (X, ω) from⁴ (M_1, α_1) to (M_2, α_2) is an exact symplectic manifold with boundary $\partial X = M_1 - M_2$ and symplectic form $\omega = d\alpha$, where α restricts to α_1 on M_1 and α_2 on M_2 .

Given an exact symplectic cobordism (X, ω) , we form its *completion* $(\widehat{X}, \widehat{\omega})$ by attaching the half positive symplectization of (M_1, α_1) along $M_1 \subset \partial X$ and the half negative symplectization of (M_2, α_2) along $M_2 \subset \partial X$.

Definition 3.1.1 Let $(\widehat{X}, \widehat{\omega})$ be the completed symplectic cobordism with an almost complex structure J which is compatible with $\widehat{\omega}$ and is adapted to α_1 and α_2 at the positive and negative ends. Then the image of an embedding

$$\phi: (\mathbb{R} \times U, d(e^s \alpha_0), J_0) \hookrightarrow (\widehat{X}, \widehat{\omega}, J)$$

is called a *product region* if $\phi_*(d(e^s \alpha_0)) = \widehat{\omega}$, $\phi_* J_0 = J$, J_0 is adapted to α_0 and, at the ends of $\mathbb{R} \times U$, $\phi(s, x) = (s + C_i, \phi_i(x))$ for $i = 1, 2$, for some embedding $\phi_i: U \rightarrow M_i$ and constant C_i .

The main technical result of [Hutchings and Taubes 2013] is the following (the first item in (i) is a slight improvement due to Cristofaro-Gardiner [2013, Theorem 5.1]):

⁴This is the convention from symplectic field theory [Eliashberg et al. 2000] and is opposite from the one used in Heegaard Floer homology, for example.

Theorem 3.1.2 [Hutchings and Taubes 2013, Theorem 1.9] *Let (M_1, α_1) and (M_2, α_2) be contact 3-manifolds and let (X, ω) be an exact symplectic cobordism from (M_1, α_1) to (M_2, α_2) . Suppose the contact forms α_1 and α_2 are nondegenerate. Then, for each positive real number L , there exists a map*

$$\Phi^L(X, \omega): \text{ECH}^L(M_1, \alpha_1) \rightarrow \text{ECH}^L(M_2, \alpha_2)$$

such that:

- (i) *Let J be a regular almost complex structure on \widehat{X} which is $\widehat{\omega}$ -compatible and is adapted to α_i at the positive and negative ends. Then $\Phi^L(X, \omega)$ is induced from a (noncanonical) chain map*

$$\widehat{\Phi}^L(X, \omega, J): \text{ECC}^L(M_1, \alpha_1, J|_{M_1}) \rightarrow \text{ECC}^L(M_2, \alpha_2, J|_{M_2}),$$

which is supported on the J -holomorphic curves, ie:

- $\langle \widehat{\Phi}^L(X, \omega, J)(\gamma), \gamma' \rangle = 0$ if there is no $I = 0, J$ -holomorphic building from γ to γ' in \widehat{X} .
- If the only J -holomorphic building in \widehat{X} from γ to γ' is a union of covers of product cylinders contained in a product region, then $\langle \widehat{\Phi}^L(X, \omega, J)(\gamma), \gamma' \rangle = 1$.

- (ii) *The map $\Phi^L(X, \omega)$ only depends on L and (X, ω) , and not on any auxiliary almost complex structure J on $(\widehat{X}, \widehat{\omega})$. Moreover, it depends on ω only through its homotopy class as an exact symplectic form.*

- (iii) *If $L < L'$, then the following diagram commutes:*

$$(3-1-1) \quad \begin{array}{ccc} \text{ECH}^L(M_1, \alpha_1) & \xrightarrow{\Phi^L(X, \omega)} & \text{ECH}^L(M_2, \alpha_2) \\ \downarrow i_{L, L'} & & \downarrow i_{L, L'} \\ \text{ECH}^{L'}(M_1, \alpha_1) & \xrightarrow{\Phi^{L'}(X, \omega)} & \text{ECH}^{L'}(M_2, \alpha_2) \end{array}$$

Hence the maps pass to the direct limit

$$\Phi(X, \omega): \text{ECH}(M_1, \alpha_1) \rightarrow \text{ECH}(M_2, \alpha_2).$$

- (iv) *Suppose (X, ω) is the composition of exact symplectic cobordisms (X_1, ω_1) from (M_1, α_1) to (M', α') and (X_2, ω_2) from (M', α') to (M_2, α_2) , and α' is nondegenerate. Then*

$$\Phi^L(X, \omega) = \Phi^L(X_2, \omega_2) \circ \Phi^L(X_1, \omega_1).$$

- (v) *If $c > 0$, then the diagram*

$$(3-1-2) \quad \begin{array}{ccc} \text{ECH}^L(M_1, \alpha_1) & \xrightarrow{\Phi^L(X, \omega)} & \text{ECH}^L(M_2, \alpha_2) \\ \downarrow s & & \downarrow s \\ \text{ECH}^{cL}(M_1, c\alpha_1) & \xrightarrow{\Phi^{cL}(X, c\omega)} & \text{ECH}^{cL}(M_2, c\alpha_2) \end{array}$$

commutes, where s is the canonical rescaling isomorphism.

(vi) If $X = [0, a] \times M$ and $\omega = d(e^s \alpha)$ with α nondegenerate, then

$$\Phi^L(X, \omega): \text{ECH}^L(M, e^a \alpha) \rightarrow \text{ECH}^L(M, \alpha)$$

is equal to the composition

$$\text{ECH}^L(M, e^a \alpha) \xrightarrow{s} \text{ECH}^{e^{-a}L}(M, \alpha) \xrightarrow{i_{e^{-a}L, L}} \text{ECH}^L(M, \alpha).$$

Remark 3.1.3 The maps involved in this result are borrowed from Seiberg–Witten theory via Taubes’s isomorphism, where one counts solutions of the perturbed Seiberg–Witten equations on the cobordism. As we take a perturbation parameter r to be large, these solutions concentrate near a holomorphic building. It is however not known yet how to reconstruct the count of solutions from just knowing the limit holomorphic building. This explains why there is no direct definition of cobordism maps by a count of holomorphic buildings and also why there is no direct proof of invariance for ECH.

Definition 3.1.4 A contact form α is called L -nondegenerate if all Reeb orbits of action less than L are nondegenerate and there is no orbit set of action exactly L .

The action-truncated ECH groups $\text{ECH}^L(M, \alpha)$ make sense for contact forms α which are L -nondegenerate and Theorem 3.1.2(i), (ii) and (iv) hold for L -nondegenerate contact forms.

All exact cobordisms considered in this paper will be of the following type:

Definition 3.1.5 An *interpolating cobordism* from (M, α_1) to (M, α_0) is an exact symplectic cobordism $([0, 1] \times M, \lambda)$ from α_1 to α_0 such that λ is of the form

$$\lambda = \Phi^*(f\alpha),$$

where α is the pullback to $[0, 1] \times M$ of a 1-form (also called α) on M , $f: [0, 1] \times M \rightarrow \mathbb{R}$ is a positive function with $\partial f / \partial t > 0$, and $\Phi: [0, 1] \times M \xrightarrow{\sim} [0, 1] \times M$ is a diffeomorphism taking $\{i\} \times M$ to itself for $i = 0, 1$.

In this article, interpolating cobordisms are all constructed as follows: Let α_0 and α_1 be isotopic contact forms on M and let $\{\phi_t: M \xrightarrow{\sim} M\}_{t \in [0, 1]}$ be an isotopy such that

- $\phi_t^*(f_t \alpha_0) = \alpha_t$ for all $t \in [0, 1]$;
- $\{f_t\}$ and $\{\alpha_t\}$ are 1-parameter families of functions and 1-forms on M ; and
- $\phi_0 = \text{id}$ and $f_0 = 1$.

Then define $\Phi: [0, 1] \times M \rightarrow [0, 1] \times M$ by $\Phi(t, \mathbf{x}) = \phi_t(\mathbf{x})$, $f: [0, 1] \times M \rightarrow \mathbb{R}$ by $f(t, \mathbf{x}) = f_t(\mathbf{x})$, and $\lambda_\phi := \Phi^*(f\alpha_0)$. If $\partial f_t / \partial t > 0$, then

$$([0, 1] \times M, \lambda_\phi)$$

is an interpolating cobordism. Interpolating cobordisms do not necessarily exist between any two isotopic α_0 and α_1 , but one can always construct them at the small price of scaling one of the two forms by a constant.

Lemma 3.1.6 *Let $([0, 1] \times M, \lambda_\phi)$ and $([0, 1] \times M, \lambda'_\phi)$ be interpolating cobordisms from (M, α_1) to (M, α_0) defined by contact isotopies ϕ and ϕ' , respectively. If the isotopies $\{\phi_t\}$ and $\{\phi'_t\}$ are homotopic relative to the endpoints, then λ_ϕ and λ'_ϕ are homotopic as exact symplectic forms.*

Proof Define $\Phi(t, \mathbf{x}) = \phi_t(\mathbf{x})$ and $\Phi'(t, \mathbf{x}) = \phi'_t(\mathbf{x})$. Without loss of generality we can write $\lambda_0 := \lambda_\phi = \Phi^*(f\alpha)$ and $\lambda_1 := \lambda'_\phi = (\Phi')^*(f'\alpha)$ with the same form α in both definitions. Let $\{\Phi_s\}$ be a homotopy between Φ and Φ' such that

- $\Phi_0 = \Phi$ and $\Phi_1 = \Phi'$;
- $\Phi_s(0, \mathbf{x}) = \mathbf{x}$ and $\Phi_s(1, \mathbf{x}) = \phi_1(\mathbf{x}) = \phi'_1(\mathbf{x})$ for all $s \in [0, 1]$.

Also define $F_s(t, \mathbf{x}) = (1 - s)f(t, \mathbf{x}) + sf'(t, \mathbf{x})$. Then

$$\lambda_s = \Phi_s^*(F_s\alpha)$$

is a homotopy of exact symplectic forms because $\partial F_s / \partial t > 0$ for all $s \in [0, 1]$. □

Lemma 3.1.7 *Let α be a contact form, $L, L' > 0$ real numbers, $\phi_t : M \rightarrow M$ for $t \in [0, 1]$ an isotopy such that $\phi_0 = \text{id}$, and $f, f' : M \rightarrow \mathbb{R}^+$ smooth functions such that $Lf' < L'f$. If $f\alpha$ and $f'\alpha$ are L - and L' -nondegenerate, respectively, then there is a map*

$$\text{ECH}^L(M, \phi_1^*(f\alpha)) \rightarrow \text{ECH}^{L'}(M, f'\alpha).$$

Moreover, this map depends only on the homotopy class of $\{\phi_t\}$ relative to the endpoints and has the following properties:

- (a) If $f = f'$ and $\phi_t \equiv \text{id}$ for $t \in [0, 1]$, then the map is induced by the inclusion of chain complexes.
- (b) If $L'' > 0$, $f'' : M \rightarrow \mathbb{R}^+$ is another function such that $L'f'' < L''f'$, and $\phi_t : M \rightarrow M$ for $t \in [1, 2]$ is an extension of the isotopy, then the following triangle commutes:

$$\begin{array}{ccc} \text{ECH}^L(M, \phi_2^*(f\alpha)) & \xrightarrow{\hspace{10em}} & \text{ECH}^{L''}(M, f''\alpha) \\ & \searrow & \nearrow \\ & \text{ECH}^{L'}(M, \phi_1^*(f'\alpha)) & \end{array}$$

Proof The inequality $Lf' < L'f$ implies that there is an interpolating cobordism with $L'\phi_1^*(f\alpha)$ at the positive end and $Lf'\alpha$ at the negative end. We define the map $\text{ECH}^L(M, \phi_1^*(f\alpha)) \rightarrow \text{ECH}^{L'}(M, f'\alpha)$

by the composition

$$\begin{array}{ccc} \text{ECH}^L(M, \phi_1^*(f\alpha)) & \longrightarrow & \text{ECH}^{L'L}(M, L'\phi_1^*(f\alpha)) \\ & & \downarrow \\ & & \text{ECH}^{L'L}(M, Lf'\alpha) \longrightarrow \text{ECH}^{L'}(M, f'\alpha), \end{array}$$

where the map $\text{ECH}^{L'L}(M, L'\phi_1^*(f\alpha)) \rightarrow \text{ECH}^{L'L}(M, Lf'\alpha)$ is the map induced by an interpolating cobordism from $L'\phi_1^*(f\alpha)$ to $Lf'\alpha$ and the horizontal maps are rescaling isomorphisms. The resulting map depends only on the homotopy class of $\{\phi_t\}$ relative to the endpoints by Lemma 3.1.6. The properties of these maps are an immediate consequence of Theorem 3.1.2. \square

3.2 Direct limits

One consequence of Theorem 3.1.2 is the following theorem, whose statement and proof were communicated to the authors by Michael Hutchings:

Theorem 3.2.1 (Hutchings and Taubes) *Let M be a closed oriented 3-manifold with a nondegenerate contact form α and $\{f_i\}_{i=1}^\infty$ a sequence of smooth positive functions such that $1 \geq f_1 \geq f_2 \geq \dots$ and $f_i\alpha$ is L_i -nondegenerate for an increasing sequence of positive real numbers L_i such that $\lim_{i \rightarrow \infty} L_i = +\infty$. Then there is a canonical isomorphism*

$$\text{ECH}(M, \alpha) \simeq \varinjlim_{i \rightarrow \infty} \text{ECH}^{L_i}(M, f_i\alpha).$$

Proof We have a map

$$f: \text{ECH}(M, \alpha) \rightarrow \varinjlim_{i \rightarrow \infty} \text{ECH}^{L_i}(M, f_i\alpha),$$

obtained by taking the direct limit of the cobordism maps

$$\text{ECH}^{L_i}(M, \alpha) \rightarrow \text{ECH}^{L_i}(M, f_i\alpha).$$

Choose an increasing sequence of natural numbers c_i such that $L_{c_i} f_i > L_i$. Then there are maps

$$\text{ECH}^{L_i}(M, f_i\alpha) \rightarrow \text{ECH}^{L_{c_i}}(M, \alpha)$$

by Lemma 3.1.7. These maps form a directed system, and, taking the direct limit, we obtain a map

$$g: \varinjlim_{i \rightarrow \infty} \text{ECH}^{L_i}(M, f_i\alpha) \rightarrow \text{ECH}(M, \alpha).$$

The verification that the maps f and g are inverse of each other is a straightforward application of Lemma 3.1.6. \square

We can now quantify when it makes sense to take direct limits of a sequence of contact forms α_i for isotopic contact structures. In this case we can write $\phi_i^*(\alpha_i) = f_i\alpha$ for some positive function f_i and diffeomorphism ϕ_i isotopic to the identity.

Definition 3.2.2 Let α be a contact form on M . A sequence $\{\alpha_i\}_{i=1}^\infty$ of contact forms on M is *commensurate to α* if there is a constant $0 < c < 1$, diffeomorphisms ϕ_i of M isotopic to the identity, and functions $f_i: M \rightarrow \mathbb{R}^{>0}$ such that $\phi_i^*\alpha_i = f_i\alpha$ and $c < |f_i|_{C^0} < 1/c$.

A corollary of Theorem 3.2.1 is the following:

Corollary 3.2.3 *Let $\{\alpha_i\}$ be a sequence of contact 1-forms on M which is commensurate to α on M with constant $0 < c < 1$. If $L_i \rightarrow \infty$ is a sequence which satisfies $L_{i+1} > L_i/c^3$ for all i , then the groups $\text{ECH}^{L_i}(M, \alpha_i)$ form a directed system with the maps defined in Lemma 3.1.7 and we have*

$$\text{ECH}(M) = \lim_{i \rightarrow \infty} \text{ECH}^{L_i}(M, \alpha_i).$$

Proof Define $L'_i = c^{2i} L_i$ and $g_i = c^{2i} f_i$. Then $\lim_{i \rightarrow \infty} L'_i = +\infty$ and $1 > g_1 > \dots > g_i > \dots$, so we can apply Theorem 3.2.1 to the sequences L'_i and g_i . □

4 Morse–Bott theory

In this section we discuss a special case of Morse–Bott theory as it applies to our context. In particular, we explain how to use Theorem 3.2.1 to justify the Morse–Bott arguments which populate this paper. For a more detailed discussion of Morse–Bott theory in contact homology, the reader is referred to Bourgeois [2003; 2002].

4.1 Morse–Bott contact forms

Let α be a *Morse–Bott contact form* on M . For the purposes of this paper, this means that all the orbits either are isolated and nondegenerate, or come in S^1 -families and are nondegenerate in the normal direction. (In general, there is also the case where the Reeb orbits come in two-dimensional families, ie are the fibers of a circle bundle; however, this will not occur here.) We denote a Morse–Bott family of simple orbits by \mathcal{N} and the Morse–Bott torus corresponding to \mathcal{N} by $T_{\mathcal{N}} = \bigcup_{x \in \mathcal{N}} x$.

Let $\{v_1, v_2\}$ be an oriented basis for ξ at some point $p \in T_{\mathcal{N}}$ such that v_1 is transverse to $T_{\mathcal{N}}$ and v_2 is tangent to $T_{\mathcal{N}}$. The derivative of the first return map $\xi_p \rightarrow \xi_p$ of the Reeb flow is given by the matrix $\begin{pmatrix} 1 & 0 \\ a & 1 \end{pmatrix}$ with respect to the basis $\{v_1, v_2\}$. (Here a vector $v = a_1 v_1 + a_2 v_2$ is written as a column vector.) The Morse–Bott condition implies that $a \neq 0$.

Definition 4.1.1 $T_{\mathcal{N}}$ is called a *positive* Morse–Bott torus if $a > 0$ and a *negative* Morse–Bott torus if $a < 0$.

Let us identify a sufficiently small neighborhood of a Morse–Bott torus $T_{\mathcal{N}}$ with $T^2 \times [-\nu, \nu]$ with coordinates (θ, t, y) such that the Reeb vector field is a positive constant times ∂_t along $T_{\mathcal{N}} = \{y = 0\}$. For a positive Morse–Bott torus, the Reeb vector field rotates in a counterclockwise manner as y goes from ν to $-\nu$ (ie in the same direction as a positive contact structure), while for a negative Morse–Bott torus it rotates in a clockwise manner.

On each $\mathcal{N} \simeq S^1$, we pick a Morse function $\bar{g}_{\mathcal{N}}: \mathcal{N} \rightarrow \mathbb{R}$ with two critical points. After perturbing α using these functions, each Morse–Bott family gives rise to an elliptic orbit e and a hyperbolic orbit h .

We choose specific α and perturbations α_ϵ as follows: Fix a real constant $L > 0$ such that no Reeb orbit of α has α -action equal to L and let $\mathcal{N}_1, \dots, \mathcal{N}_n$ be the Morse–Bott families consisting of simple orbits with α -action less than L . On the small neighborhood $T^2 \times [-\nu, \nu]$ of $T_{\mathcal{N}_i}$, we set

$$(4-1-1) \quad \alpha = C dt + \delta(f dt + y d\theta), \quad \alpha_\epsilon = C dt + \delta(f_\epsilon dt + y d\theta),$$

where $\epsilon > 0$ and $\delta > 0$ are small, $C > 0$ is the action of the Reeb orbits of \mathcal{N}_i , and:

- (P1) $f(y, \theta) = \pm \frac{1}{2}y^2$ and $f_\epsilon(y, \theta) = \pm(\frac{1}{2}y^2 + \epsilon\phi(y)\bar{g}_{\mathcal{N}}(\theta))$, where the sign \pm depends on whether we have a negative or positive Morse–Bott torus.
- (P2) $\bar{g}_{\mathcal{N}}: \mathbb{R}/\mathbb{Z} \rightarrow \mathbb{R}$ is a perfect Morse function with maximum at $\frac{1}{4}$ and minimum at $-\frac{1}{4}$. More specifically, we assume that $\bar{g}'_{\mathcal{N}}(\theta)$ is 0 on $\theta = \pm\frac{1}{4}$, is linear with positive slope on $[-\frac{1}{4}, -\frac{1}{5}]$, is nondecreasing on $[-\frac{1}{5}, -\frac{1}{6}]$, and is equal to 1 on $[-\frac{1}{6}, \frac{1}{6}]$; and $\bar{g}_{\mathcal{N}}(\theta)$ is an odd function about $\theta = 0$.
- (P3) $\phi: [-\nu, \nu] \rightarrow [0, 1]$ is an even bump function with support on $[-a, a]$ and is equal to 1 on $[-b, b]$, where $\nu > a > b > 0$ are sufficiently small.

In particular, (P1) implies:

$$(P4) \quad \text{As } \epsilon \rightarrow 0, f_\epsilon \rightarrow f \text{ in } C^\infty.$$

Proposition 4.1.2 *Let α be a Morse–Bott contact form. After a small modification of α near the \mathcal{N}_i , which we still call α , for every $L > 0$ there exist $\delta > 0$, $\nu > 0$ and $\epsilon > 0$ small such that:*

- (1) α_ϵ is L -nondegenerate and satisfies (4-1-1) and conditions (P1)–(P4).
- (2) Each \mathcal{N}_i is perturbed into a pair of nondegenerate Reeb orbits e_i and h_i of α_ϵ -action less than L .
- (3) All multiples e_i^k and h_i^k of α_ϵ -action less than L have Conley–Zehnder indices 1 and 0 if \mathcal{N}_i is positive, and -1 and 0 if \mathcal{N}_i is negative.
- (4) All other orbits which are created have α_ϵ -action greater than L .

Here the Conley–Zehnder indices are computed with respect to the trivialization τ induced from \mathcal{N}_i .

Strictly speaking, we make the modification of α in Proposition 4.1.2 so that it satisfies the conditions of Lemma A.9.4.

Let \mathcal{P}' be the set of simple nondegenerate orbits of R_α and let $\mathcal{P}_{\text{MB}} = \mathcal{P}' \cup (\bigcup_i \mathcal{N}_i)$ be the set of all simple Reeb orbits of R_α , where \mathcal{N}_i denotes a Morse–Bott family of simple orbits. An orbit set γ for the Morse–Bott contact form α is an orbit set constructed from $\mathcal{P} = \mathcal{P}' \cup (\bigcup_i \{h_i, e_i\})$, where h_i is treated as a hyperbolic orbit (in particular, its multiplicity cannot be greater than one) and e_i is treated as an elliptic orbit.

4.2 Morse–Bott buildings

Let J be an almost complex structure on $\mathbb{R} \times M$ which is adapted to the Morse–Bott contact form α . We also assume the following:

- (*) For each Morse–Bott torus $T_{\mathcal{N}} = T^2$, J is invariant in the s -, t - and θ -directions on $\mathbb{R} \times T^2 \times [-v, v]$ and the projection of $J|_{\ker \alpha}$ to $(\mathbb{R}/\mathbb{Z}) \times [-v, v]$ with coordinates (θ, y) is the standard complex structure $\partial/\partial y \mapsto \partial/\partial \theta$.

(Strictly speaking, we require α and J to satisfy the conditions of Lemma A.9.4; this can be arranged by a small modification near the Morse–Bott torus.)

Remark 4.2.1 In [Bourgeois et al. 2003], Morse–Bott compactness was proved for slightly different perturbations of α , namely for $f_\epsilon \alpha$, but it still holds in our case.

Although the notation is a bit cumbersome, consider the moduli space

$$\mathcal{M}_J(\gamma_1^+, \dots, \gamma_{i_1}^+; \mathcal{N}_1^+, \dots, \mathcal{N}_{i_2}^+; \gamma_1^-, \dots, \gamma_{i_3}^-; \mathcal{N}_1^-, \dots, \mathcal{N}_{i_4}^-),$$

abbreviated $\mathcal{M}_J(\gamma^+, \mathcal{N}^+, \gamma^-, \mathcal{N}^-)$, of J -holomorphic maps u in $\mathbb{R} \times M$ which have positive ends at orbits $\gamma_1^+, \dots, \gamma_{i_1}^+, \tilde{\gamma}_1^+, \dots, \tilde{\gamma}_{i_2}^+$ and negative ends at orbits $\gamma_1^-, \dots, \gamma_{i_3}^-, \tilde{\gamma}_1^-, \dots, \tilde{\gamma}_{i_4}^-$, where γ_i^\pm covers a simple orbit in \mathcal{P}' with multiplicity $l_i^\pm \geq 1$ and $\tilde{\gamma}_i^\pm$ covers a simple orbit in the Morse–Bott family \mathcal{N}_i^\pm with multiplicity $k_i^\pm \geq 1$.

We say that J satisfying (*) is *Morse–Bott regular* if, for all data $\gamma^+, \mathcal{N}^+, \gamma^-$ and \mathcal{N}^- and any $u \in \mathcal{M}_J(\gamma^+, \mathcal{N}^+, \gamma^-, \mathcal{N}^-)$ which has no multiply covered components, $\mathcal{M}_J(\gamma^+, \mathcal{N}^+, \gamma^-, \mathcal{N}^-)$ is transversely cut out (and hence is a manifold) near u . Since it suffices to perturb J outside of the sufficiently small neighborhood $\mathbb{R} \times T^2 \times [-v, v]$, a generic J satisfying (*) is regular.

We now give the definition of a Morse–Bott building. See [Bourgeois et al. 2003, Section 11.2] for a similar definition.

Definition 4.2.2 Let γ and γ' be orbit sets constructed from \mathcal{P} . A *Morse–Bott building* \tilde{u} consists of a set $\{u_i: F_i \rightarrow \mathbb{R} \times M \mid i = 1, \dots, n\}$ of holomorphic maps with possibly disconnected domains F_i and a set $\{\delta_{i,j} \mid i = 0, \dots, n, j = 1, \dots, j_i\}$ of gradient flow lines in $\bigcup_k \mathcal{N}_k$ such that the following hold:

- (a) For $i = 1, \dots, n - 1$, the negative ends $\mathcal{E}_{i,j}^-$ of u_i are paired with positive ends $\mathcal{E}_{i+1,j'}^+$ of u_{i+1} . Paired ends $(\mathcal{E}_{i,j}^-, \mathcal{E}_{i+1,j'}^+)$ are asymptotic to $k_{i,j}$ -fold covers of simple orbits $(\gamma_{i,j}^-, \gamma_{i+1,j'}^+)$ in the same Morse–Bott family and $\delta_{i,j}$ is a gradient flow line from $\gamma_{i,j}^-$ to $\gamma_{i+1,j'}^+$. (Here $\delta_{i,j}$ can be viewed as a $k_{i,j}$ -fold unbranched cover of a cylinder connecting $\gamma_{i,j}^-$ to $\gamma_{i+1,j'}^+$.)
- (b) Positive ends $\mathcal{E}_{1,j}^+$ of u_1 and negative ends $\mathcal{E}_{n,j}^-$ of u_n which are asymptotic to Reeb orbits in $\bigcup_k \mathcal{N}_k$ are augmented by gradient flow lines $\delta_{0,j}$ and $\delta_{n,j}$ connecting the orbit from/to a critical point of the appropriate Morse function $\bar{g}_{\mathcal{N}_k}$ determined by γ or γ' .

- (c) A nondegenerate orbit is considered as a Morse–Bott family consisting of a single point, and in this case the gradient flow line has length zero.

Given two orbit sets γ and γ' constructed from \mathcal{P} , the set of Morse–Bott buildings \tilde{u} from γ to γ' will be denoted by $\mathcal{M}_J^{\text{MB}}(\gamma, \gamma')$.

The collection of maps u_i will be called the *holomorphic part* of the building. The restriction of any map u_i to a connected component of its domain will be called an *irreducible holomorphic component* of \tilde{u} .

Definition 4.2.3 A Morse–Bott building \tilde{u} from γ to γ' is *simply covered* if every multiply covered irreducible holomorphic component of \tilde{u} is either

- (i) a branched cover of a trivial cylinder over a simple orbit in \mathcal{P} ; or
- (ii) an unbranched cover of a trivial cylinder over a simple orbit in $\mathcal{P}_{\text{MB}} - \mathcal{P}$.

Note that this definition allows connectors over the orbits e and h of every Morse–Bott torus, but not connectors over any other Morse–Bott orbit, which would necessarily break a gradient flow line. This second type of connector would make gluing more complicated.

4.3 ECH and Fredholm indices

In this subsection we define the ECH and Fredholm indices of a Morse–Bott building.

Definition 4.3.1 The ECH index $I(\gamma, \gamma', Z)$ in the Morse–Bott setting is defined, as in the nondegenerate case, as

$$I(\gamma, \gamma', Z) = c_1(\xi|_Z, \tau) + Q_\tau(Z) + \tilde{\mu}_\tau(\gamma) - \tilde{\mu}_\tau(\gamma'),$$

where the symmetric Conley–Zehnder indices of γ and γ' are computed with the convention that $\mu_\tau(e_i^j) = 1$ for all j and $\mu_\tau(h_i) = 0$ if \mathcal{N}_i is a positive Morse–Bott family and $\mu_\tau(h_i) = 0$ and $\mu_\tau(e_i^j) = -1$ for all j if \mathcal{N}_i is a negative Morse–Bott family. Here $\tau|_{\mathcal{N}_i}$ is the trivialization defined by \mathcal{N}_i .

Remark 4.3.2 The ECH index computed with this definition coincides with the limit of ECH indices computed with respect to nondegenerate perturbations α_ϵ of the Morse–Bott contact form α as $\epsilon \rightarrow 1$.

As in the nondegenerate case, a Morse–Bott building \tilde{u} from γ to γ' determines a relative homology class $Z \in H_2(M, \gamma, \gamma')$ which is obtained from projecting the holomorphic part to M and gluing the annuli corresponding to the gradient trajectories. In view of this construction, we will often write $I(\tilde{u})$ for $I(\gamma, \gamma', Z)$.

We can also define the Fredholm index of a Morse–Bott building as follows. To a building \tilde{u} we associate a map $u_\# : F_\# \rightarrow \mathbb{R} \times M$ by cutting the ends of the holomorphic components of u and connecting them with

cylinders corresponding to the gradient trajectories. Then the Fredholm index of a Morse–Bott building \tilde{u} which is positively asymptotic to Reeb orbits $\gamma_i^{m_{ij}}$ and negatively asymptotic to Reeb orbits $(\gamma'_i)^{m'_{ij}}$ is

$$(4-3-1) \quad \text{ind}(\tilde{u}) = -\chi(F_{\#}) + 2c_1(u_{\#}^* \xi, \tau) + \sum_{ij} \mu_{\tau}(\gamma_i^{m_{ij}}) - \sum_{ij} \mu_{\tau}((\gamma'_i)^{m'_{ij}}),$$

with the same convention for the Conley–Zehnder indices of h_i, e_i and their iterates as in Definition 4.3.1. (See [Bourgeois 2002, Corollary 5.4].)

4.4 Morse–Bott chain complex

In this subsection we introduce a Morse–Bott version of the ECH chain complex. Due to technical difficulties concerning non-simply covered Morse–Bott buildings, we will develop an ECH Morse–Bott theory only for special Morse–Bott contact forms, which we call *nice*.

Definition 4.4.1 (1) A Morse–Bott building \tilde{u} is *nice* if its holomorphic part has at most one irreducible component which is not a connector. This irreducible component will be called the *principal part* of \tilde{u} .

(2) A Morse–Bott building \tilde{u} is *very nice* if it is nice and every irreducible component besides the principal part is an unbranched cover of a trivial cylinder.

(3) A Morse–Bott contact form α on M is *nice* if, for a generic almost complex structure J , all J -holomorphic Morse–Bott buildings of ECH index $I = 1$ in the symplectization of (M, α) are nice.

Remark 4.4.2 We will consider contact forms on manifolds with torus boundary which are non-degenerate on the interior and Morse–Bott on the boundary. Such contact forms are automatically nice (see Lemma 7.1.2). It is not clear whether nice contact forms with $\bigcup_i \mathcal{N}_i \neq \emptyset$ exist on closed manifolds.

Now we describe the relation between moduli spaces of J -holomorphic Morse–Bott buildings for a Morse–Bott contact form α and moduli spaces of holomorphic maps for generic perturbations of α following [Bourgeois 2002]. Our statement will be weaker than that of [Bourgeois 2002] because we are going to state only what can be proved without resorting to abstract perturbations.

Let J_0 be a Morse–Bott regular almost complex structure on $\mathbb{R} \times M$ adapted to α , and let J_{ϵ} be almost complex structures on $\mathbb{R} \times M$ adapted to the contact forms α_{ϵ} in Proposition 4.1.2 such that:

(**) For each Morse–Bott torus $T_{\mathcal{N}} = T^2$, J_{ϵ} is invariant in the s - and t -directions on $\mathbb{R} \times T^2 \times [-\nu, \nu]$ and the projection of $J_{\epsilon}|_{\ker \alpha}$ to $(\mathbb{R}/\mathbb{Z}) \times [-\nu, \nu]$ with coordinates (θ, y) is the standard complex structure $\partial/\partial y \mapsto \partial/\partial \theta$.

In particular, $\lim_{\epsilon \rightarrow 0} J_{\epsilon} = J_0$ in the C^{∞} -topology.

Theorem 4.4.3 *Let α be a Morse–Bott contact form on M . Fix $L > 0$. Then there exist δ, ν, ϵ and α_ϵ as in Proposition 4.1.2, J_0 Morse–Bott regular satisfying $(*)$, and α_ϵ -adapted regular J_ϵ satisfying $(**)$ as in the previous paragraph such that, for all orbit sets $\gamma, \gamma' \in \mathcal{P}$ with action less than L , the following holds:*

- (1) *For all sequences $\epsilon_i \rightarrow 0$ and $u_i \in \mathcal{M}_{J_{\epsilon_i}}(\gamma, \gamma')$, there is a subsequence u_{i_k} which converges to a Morse–Bott building in $\mathcal{M}_{J_0}^{\text{MB}}(\gamma, \gamma')$.*
- (2) *If \tilde{u} is a very nice, simply covered Morse–Bott building, then there is a J_ϵ -holomorphic map $u_\epsilon \in \mathcal{M}_{J_\epsilon}(\gamma, \gamma')$ which is “close to breaking” into \tilde{u} and a curve $u_{\mathcal{T}_0^\epsilon}$ corresponding to a gradient trajectory \mathcal{T}_0^ϵ of f_ϵ along $y = 0$.*
- (3) *If $\text{ind}(\tilde{u}) = 1$, then the mod 2 algebraic count of $[u_\epsilon] \in \mathcal{M}_{J_\epsilon}(\gamma, \gamma')/\mathbb{R}$ that are “close to breaking” into \tilde{u} and $u_{\mathcal{T}_0^\epsilon}$ is one.*
- (4) *If $\text{ind}(\tilde{u}) = 2$ and \tilde{u} passes through a generic point $z \in \mathbb{R} \times M$, then the mod 2 algebraic count of $u_\epsilon \in \mathcal{M}_{J_\epsilon}(\gamma, \gamma')$ that are “close to breaking” into \tilde{u} and $u_{\mathcal{T}_0^\epsilon}$ and passing through z is one.*

Proof (1) follows from Morse–Bott SFT compactness [Bourgeois et al. 2003; Bourgeois 2002]. The proofs of (2) and (3) are given in the appendix; (4) is similar. \square

Lemma 4.4.4 *Let J be a Morse–Bott regular almost complex structure and let $\tilde{u} \in \mathcal{M}_J^{\text{MB}}(\gamma, \gamma')$ be a very nice Morse–Bott building with $I(\tilde{u}) = 1$. Then \tilde{u} is simply covered and $\text{ind}(\tilde{u}) = 1$.*

Proof Assume that \tilde{u} has no trivial cylinders. In the general case, removing the trivial cylinders of \tilde{u} might decrease the ECH index by [Hutchings 2009, Theorem 5.1] and positivity of intersection, but the same argument holds.

We first consider the case when the principal part u of \tilde{u} is nonempty. Suppose that u is a k -fold branched cover of a nontrivial simply covered J -holomorphic curve v . Let \tilde{v} be the Morse–Bott building obtained by augmenting v with gradient trajectories. If the functions \bar{g}_N are chosen generically, then $\text{ind}(\tilde{v}) > 0$ by the regularity of J . Since \tilde{v} is a very nice simply covered J -holomorphic building, by Theorem 4.4.3(2) we can perturb it to a J_ϵ -holomorphic map v_ϵ for ϵ small. Then $I(v_\epsilon) \geq \text{ind}(v_\epsilon) > 0$ by the ECH index inequality (Theorem 2.3.3), so $I(\tilde{v}) > 0$. Consider the J_ϵ -holomorphic curve v_ϵ^k given by k translated copies of v_ϵ . Since both \tilde{u} and v_ϵ^k represent the same relative homology class in $H_2(M, \gamma, \gamma')$, we have $I(\tilde{u}) = I(v_\epsilon^k)$. Since $I(v_\epsilon^k) \geq kI(v_\epsilon)$ by [Hutchings 2009, Theorem 5.1 and Proposition 5.6], it follows that $I(\tilde{u}) \geq k$. Hence $k = 1$ and u is simply covered.

Next let u_ϵ be the simply covered J_ϵ -holomorphic map which corresponds to \tilde{u} under an arbitrarily small generic perturbation of the Morse–Bott contact form by Theorem 4.4.3(2). Clearly $I(u_\epsilon) = I(\tilde{u}) = 1$, so $\text{ind}(u_\epsilon) = 1$ and $\text{ind}(\tilde{u}) = 1$. This implies the lemma when the principal part of \tilde{u} is nonempty.

If the principal part is empty, then \tilde{u} consists of a gradient trajectory on a Morse–Bott family and a gradient trajectory has ECH index one. \square

Lemma 4.4.5 *Let α be a nice Morse–Bott contact form. If we fix a regular almost complex structure J_0 adapted to α , then, for any orbit sets γ and γ' and any $\epsilon > 0$ sufficiently small, there is a bijection*

$$\mathcal{M}_{J_0}^{\text{MB}, I=1, \text{vn}}(\gamma, \gamma')/\mathbb{R} \simeq \mathcal{M}_{J_\epsilon}^{I=1, \text{tn}}(\gamma, \gamma')/\mathbb{R}.$$

Here the modifier vn stands for “very nice” and the modifier tn means that all the connectors are trivial cylinders.

Proof By Theorem 4.4.3 and Lemma 4.4.4, every very nice $I = 1$, J_0 -holomorphic Morse–Bott building can be deformed into an $I = 1$, J_ϵ -holomorphic map all of whose connectors are trivial cylinders.

It remains to show that every sequence v_i of J_{ϵ_i} -holomorphic maps with $I(v_i) = 1$ and trivial cylinders as connectors converges to a very nice J_0 -holomorphic Morse–Bott building \tilde{u} as $\epsilon_i \rightarrow 0$, after possibly passing to a subsequence. Suppose without loss of generality that the domains of the maps v_i are connected. (Indeed, since $I(v_i) = 1$, discarding the possible trivial cylinders does not change $I(v_i)$ by [Hutchings 2009, Theorem 5.1] and positivity of intersection.) By Theorem 4.4.3(1), the sequence v_i converges to a Morse–Bott building \tilde{u} with $I(\tilde{u}) = 1$. Since α is a nice Morse–Bott contact form, the holomorphic part of \tilde{u} has at most one irreducible component which is not a connector. Assume there is a nontrivial principal part u_0 ; the case of $u_0 = \emptyset$ is simpler and is left to the reader. We consider the very nice Morse–Bott building \tilde{u}' obtained by augmenting the Morse–Bott ends of u_0 with gradient flow trajectories to the critical points of the Morse functions on the Morse–Bott tori. Then $I(\tilde{u}') = I(\tilde{u}) = 1$ because they represent the same relative homology class, and therefore Lemma 4.4.4 implies that u_0 is simply covered.

We claim that every other irreducible component is a trivial cylinder over an orbit in \mathcal{P} . Arguing by contradiction, suppose there are nontrivial connectors that are connected to u_0 by one or more finite-length gradient flow trajectories. We will show that $\text{ind}(\tilde{u}) > 1$, which contradicts the fact that \tilde{u} is the limit of curves v_i with $\text{ind}(v_i) = 1$. To this end we consider the Morse–Bott building \tilde{u}' defined above. We recall that \tilde{u}' is very nice, simply covered and satisfies $I(\tilde{u}') = I(\tilde{u}) = 1$.

The ends of the building \tilde{u} satisfy the incoming/outcoming partitions because \tilde{u} is the limit of J_{ϵ_i} -holomorphic maps v_i , while the ends of the building \tilde{u}' satisfy the incoming/outgoing partitions because \tilde{u}' can be deformed to J_{ϵ_i} -holomorphic maps v'_i for $i \gg 0$ by Theorem 4.4.3(2).

We now make the simplifying hypothesis that u_0 has ends only at one Morse–Bott torus. (The general case is more complicated only in the notation.) Then the ends of \tilde{u} and \tilde{u}' differ only for the multiplicity of e . We denote by n_+ and n_- the positive and negative multiplicities of e in \tilde{u} , respectively, and by n'_+ and n'_- the corresponding multiplicities in \tilde{u}' . Moreover, we denote by $\mu(e, n_\pm)$ and $\mu(e, n'_\pm)$ the contributions of ends at e to the Fredholm indices of \tilde{u} and \tilde{u}' , respectively. (We recall that these contributions are determined by the total multiplicities because \tilde{u} and \tilde{u}' satisfy the incoming/outgoing partition conditions.) We observe that $n_\pm \geq n'_\pm$ and $n_+ - n'_+ = n_- - n'_-$.

Let F be the domain of v_i and F' the domain of v'_i for $i \gg 0$. Then, by the Fredholm index formula (4-3-1),

$$\text{ind}(\tilde{u}) - \text{ind}(\tilde{u}') = -(\chi(F) - \chi(F')) + (\mu(e, n_+) - \mu(e, n_-)) - (\mu(e, n'_+) - \mu(e, n'_-)).$$

The term $\chi(F) - \chi(F')$ is the sum of the Euler characteristics of the connector components of \tilde{u} , so $-(\chi(F) - \chi(F')) > 0$ if \tilde{u} is not very nice. We claim that $(\mu(e, n_+) - \mu(e, n_-)) - (\mu(e, n'_+) - \mu(e, n'_-))$ is always nonnegative. To see this, first we compute the contributions of the ends at e to the Fredholm index. If the Morse–Bott torus is positive, then

$$\mu(e, n_+) = n_+, \quad \mu(e, n_-) = \begin{cases} 0 & \text{if } n_- = 0, \\ 1 & \text{if } n_- > 0. \end{cases}$$

On the other end, if the Morse–Bott torus is negative, then

$$\mu(e, n_+) = \begin{cases} 0 & \text{if } n_+ = 0, \\ -1 & \text{if } n_+ > 0, \end{cases} \quad \mu(e, n_-) = -n_-.$$

Similar formulas hold for $\mu(e, n'_\pm)$.

Now we focus on the case of a positive Morse–Bott torus. (The negative case is completely symmetric.) Then $(\mu(e, n_+) - \mu(e, n_-)) - (\mu(e, n'_+) - \mu(e, n'_-)) = n_+ - n'_+ \geq 0$ if $n_-, n'_- > 0$ or $n_- = n'_- = 0$. On the other hand, if $n_- > 0$ but $n'_- = 0$, we have $(\mu(e, n_+) - \mu(e, n_-)) - (\mu(e, n'_+) - \mu(e, n'_-)) = n_+ - n'_+ - 1$. However, in this case, $n_+ - n'_+ = n_- - n'_- > 0$, so $(\mu(e, n_+) - \mu(e, n_-)) - (\mu(e, n'_+) - \mu(e, n'_-)) \geq 0$.

This proves that, if \tilde{u} is not very nice, $\text{ind}(\tilde{u}) > \text{ind}(\tilde{u}')$. This is a contradiction because $\text{ind}(\tilde{u}) = 1$, as \tilde{u} is a limit of $\text{ind} = 1$ maps v_i , and $\text{ind}(\tilde{u}') > 0$ since J_0 is a Morse–Bott regular almost complex structure. \square

Definition 4.4.6 Let α be a nice Morse–Bott contact form and J a Morse–Bott regular almost complex structure adapted to the symplectization of α . Then the Morse–Bott chain complex $(\text{ECC}_{\text{MB}}(M, \alpha, J), \partial_{\text{MB}})$ is generated by orbit sets constructed from \mathcal{P} and the differential counts very nice Morse–Bott buildings with $I(\tilde{u}) = 1$. We denote by $\text{ECC}_{\text{MB}}^L(M, \alpha, J)$ the subcomplex generated by orbit sets of action less than L .

Proposition 4.4.7 Let α be a nice Morse–Bott contact form. If no Reeb orbit of α has action equal to a fixed $L > 0$, then there is an isomorphism of chain complexes

$$\text{ECC}^L(M, \alpha_\epsilon, J_\epsilon) \simeq \text{ECC}_{\text{MB}}^L(M, \alpha, J_0)$$

for all sufficiently small $\epsilon > 0$. In particular, $\partial_{\text{MB}}^2 = 0$.

Proof The isomorphism follows from Lemma 4.4.5. \square

4.5 Comparison with the nondegenerate case

In this subsection we use a direct limit argument to prove the isomorphism between ECH of a nondegenerate contact form and Morse–Bott ECH of a nice Morse–Bott form α .

Let $L_i \rightarrow \infty$ be an increasing sequence such that each L_i is positive and there is no Reeb orbit of α with action equal to L_i . Let $\mathcal{N}_1, \dots, \mathcal{N}_{n(i)}$ be the Morse–Bott families consisting of simple orbits with α -action $< L_i$. (In many useful cases, $\lim_{i \rightarrow +\infty} n(i) = +\infty$.)

The following lemma provides a sequence of perturbing functions and is an immediate corollary of Proposition 4.1.2 and Theorem 4.4.3:

Lemma 4.5.1 *Let α be a nice Morse–Bott form and let L_i be a sequence of positive constants such that $L_i \rightarrow +\infty$ and no Reeb orbit of α has action equal to L_i . There exist sequences of positive numbers $\epsilon_i \rightarrow 0$ and functions $g_i : M \rightarrow \mathbb{R}^{\geq 0}$ such that $f_i = 1 + g_i$ and:*

- (1) g_i is supported in a union of disjoint neighborhoods of $T_{\mathcal{N}_1}, \dots, T_{\mathcal{N}_{n(i)}}$.
- (2) The support of g_i is disjoint from all nondegenerate Reeb orbits of α of α -action $< L_i$.
- (3) On a sufficiently small neighborhood $T^2 \times [-\epsilon, \epsilon]$ of $T_{\mathcal{N}_j}$ for $j = 1, \dots, n(i)$, there exist precisely two simple orbits of $f_i\alpha$ of action $\leq L_i$, corresponding to elliptic and hyperbolic orbits of the perturbed Morse–Bott family.
- (4) $\lim_{i \rightarrow +\infty} f_i = 1$ in the C^k -topology for $k \gg 0$.
- (5) For every i , the contact form $f_i\alpha$ satisfies conditions (1)–(4) of Proposition 4.1.2 and the conclusion of Theorem 4.4.3 for orbits of action $\leq L_i$.
- (6) $f_i\alpha$ (resp. $f_{i+1}\alpha$) has no Reeb orbits with $f_i\alpha$ -action (resp. $f_{i+1}\alpha$ -action) in $[a_i^{-2}L_i, a_i^2L_i]$, where $a_i = (1 + \epsilon_i c_0)^2$ for some constant $c_0 > 0$.

Warning 4.5.2 For all i , Morse–Bott theory (and in particular Proposition 4.4.7) gives injections $\text{ECC}^{L_i}(M, f_i\alpha) \rightarrow \text{ECC}^{L_{i+1}}(M, f_{i+1}\alpha)$. However, the maps induced in homology by these injections a priori could be different from the canonical maps given in Lemma 3.1.7, and it is with respect to the latter that the direct limit must be taken. (A posteriori, they are shown to be the same in the proof of Theorem 4.5.9.)

Observe that $a_i^{-1}f_i < f_{i+1} < a_i f_i$ for all i . Then Lemma 3.1.7 gives maps

$$\begin{aligned} \Phi_+ &: \text{ECH}^{L_i}(M, f_i\alpha) \rightarrow \text{ECH}^{a_i L_i}(M, f_{i+1}\alpha), \\ \Phi_- &: \text{ECH}^{a_i L_i}(M, f_{i+1}\alpha) \rightarrow \text{ECH}^{a_i^2 L_i}(M, f_i\alpha), \\ \Phi'_- &: \text{ECH}^{a_i^{-1} L_i}(M, f_{i+1}\alpha) \rightarrow \text{ECH}^{L_i}(M, f_i\alpha). \end{aligned}$$

Lemma 4.5.3 *The map Φ_+ is an isomorphism.*

Proof By Theorems 3.1.2(ii) and (iv), the composition

$$\text{ECH}^{L_i}(M, a_i f_{i+1}\alpha) \rightarrow \text{ECH}^{L_i}(M, f_i\alpha) \rightarrow \text{ECH}^{L_i}(M, a_i^{-1} f_{i+1}\alpha)$$

is equal to the cobordism map induced by a piece of symplectization. Then, by Theorem 3.1.2(vi), it is a composition of a scaling with an inclusion. From this and Lemma 4.5.1(9), it follows easily that $\Phi_+ \circ \Phi'_- = \text{id}$. Similarly, $\Phi_- \circ \Phi_+ = \text{id}$. Hence Φ_+ is an isomorphism. \square

Let $([0, 1] \times M, d\lambda_i)$ be an interpolating cobordism from $f_i\alpha$ to $a_i^{-1}f_{i+1}\alpha$ and $(\mathbb{R} \times M, d\hat{\lambda}_i)$ its completion. Let \tilde{J}_i be a regular almost complex structure on $(\mathbb{R} \times M, d\hat{\lambda}_i)$ which is $d\lambda_i$ -compatible and adapted to the symplectizations of $f_i\alpha$ and $a_i^{-1}f_{i+1}\alpha$ at the ends. We denote the moduli space of \tilde{J}_i -holomorphic buildings in $(\mathbb{R} \times M, d\hat{\lambda}_i)$ from γ to γ' by $\mathcal{M}_{\tilde{J}_i}^b(\gamma, \gamma')$.

The following lemma, stated without proof, is a consequence of the Morse–Bott compactness theorem [Bourgeois 2002] and the triviality of $I < 0$ moduli spaces in symplectizations.

Lemma 4.5.4 *If $\epsilon_i > 0$ is sufficiently small, then there is a regular almost complex structure \tilde{J}_i such that, if γ and γ' have $f_i\alpha$ -actions less than L_i , then $\mathcal{M}_{\tilde{J}_i}^{b,I=0}(\gamma, \gamma')$ and $\mathcal{M}_{\tilde{J}_i}^{b,I=0}(\gamma', \gamma)$ are empty if $\gamma \neq \gamma'$ and consist of branched covers of trivial holomorphic cylinders if $\gamma = \gamma'$.*

By Morse–Bott theory, there is an identification of complexes

$$e : \text{ECC}^{L_i}(M, f_i\alpha, J_i) \xrightarrow{\cong} \text{ECC}^{a_i L_i}(M, f_{i+1}\alpha, J_{i+1}).$$

In fact, $\text{ECC}^{L_i}(M, f_i\alpha)$ and $\text{ECC}^{a_i L_i}(M, f_{i+1}\alpha)$ are generated by the same orbit sets and the moduli spaces of $I = 1$ holomorphic curves (modulo \mathbb{R} -translations) have the same cardinality, by Lemma 4.5.1 and Proposition 4.4.7. Let e_* be the map induced by e on homology.

Proposition 4.5.5 $e_* = \Phi_+$.

Proof Let

$$\hat{\Phi}_+ : \text{ECC}^{L_i}(M, f_i\alpha, J_i) \rightarrow \text{ECC}^{a_i L_i}(M, f_{i+1}\alpha, J_{i+1})$$

be a (noncanonical) chain map which induces Φ_+ and is given by Theorem 3.1.2 and Lemma 3.1.7. Theorem 3.1.2(i) and Lemma 4.5.4 imply that $\hat{\Phi}_+$ is a diagonal map. Note that $\text{ECC}^{L_i}(M, f_i\alpha)$ and $\text{ECC}^{a_i L_i}(M, f_{i+1}\alpha)$ are generated by the same orbit sets. The reason why we cannot conclude that $\hat{\Phi}_+ = e$ by Theorem 3.1.2(i) is that some of the $I = 0$ holomorphic cylinders in the interpolating cobordism from $(M, a_i f_i\alpha)$ to $(M, f_{i+1}\alpha)$ are, strictly speaking, not contained in product regions.

For \mathbb{F} -coefficients we can use the following algebraic trick to finish the proof: Identify $\text{ECC}^{a_i L_i}(M, f_{i+1}\alpha)$ with $\text{ECC}^{L_i}(M, f_i\alpha)$ via e^{-1} . Then

$$(e^{-1} \circ \hat{\Phi}_+) \circ (e^{-1} \circ \hat{\Phi}_+) = e^{-1} \circ \hat{\Phi}_+$$

over \mathbb{F} . Since Φ_+ and e_* are isomorphisms, it follows that $e_*^{-1} \circ \Phi_+ = \text{id}$ and $\Phi_+ = e_*$. □

Now we give a sketch of the proof of Proposition 4.5.5 which applies to integer coefficients. The uninterested reader can jump directly to Theorem 4.5.9. Given a pair (λ, J) consisting of a nondegenerate contact form λ and a compatible J , Taubes [2010] first perturbs (λ, J) into an L -flat pair (λ', J') before identifying $\text{ECH}^L(\lambda', J')$ with Seiberg–Witten Floer cohomology. A pair (λ', J') is L -flat if

near each Reeb orbit of length $< L$ it satisfies the conditions in [Taubes 2010, equation (4-1)], and L -flat perturbations are constructed in [Taubes 2010, Proposition 2.5 and Appendix]. (See [Taubes 2010, Section 5.c, Part 2] for the reasons for introducing the L -flat condition.)

The following lemma is a slight rephrasing of [Hutchings and Taubes 2013, Lemma 3.4(d)] and will not be proved:

Lemma 4.5.6 *If (λ^t, J^t, L^t) for $t \in [0, 1]$ is a 1-parameter family and (λ^t, J^t) is L^t -flat, λ^t is L^t -nondegenerate, and J^t is L^t -regular (ie Definition 2.2.1 holds for all γ and γ' with $\mathcal{A}_{\lambda^t}(\gamma) < L^t$) for all $t \in [0, 1]$, then the ECH cobordism map*

$$\text{ECH}^{L^0}(M, \lambda^0) \rightarrow \text{ECH}^{L^1}(M, \lambda^1)$$

is induced by the isomorphism

$$\text{ECC}^{L^0}(M, \lambda^0, J^0) \xrightarrow{\sim} \text{ECC}^{L^1}(M, \lambda^1, J^1)$$

given by the canonical bijection of generators.

Setting $\lambda^0 = f_i \alpha$ and $\lambda^1 = f_{i+1} \alpha$, it is easy to find an extension λ^t for $t \in [0, 1]$ of the form $f_{i+1}^t \alpha$, where $f_{i+1}^0 = f_i$, $f_{i+1}^1 = f_{i+1}$, and f_{i+1}^t satisfies the conditions of Lemma 4.5.1 with f_{i+1} replaced by f_{i+1}^t . By choosing f_{i+1}^t to be sufficiently close to 1 and applying Lemma 4.4.5, there exist an extension L^t for $t \in [0, 1]$ of $L^0 = L_i$ and $L^1 = a_i L_i$ and an extension J^t for $t \in [0, 1]$ of $J^0 = J_i$ and $J^1 = J_{i+1}$ such that J^t is adapted to λ^t and is L^t -regular.

Next we fix a Riemannian metric on M , with respect to which we measure distances. Assume for simplicity that there is a unique Morse–Bott torus $T_{\mathcal{N}}$. Let γ_e and γ_h be the elliptic and hyperbolic orbits of λ^t which are obtained by perturbing $T_{\mathcal{N}}$, where we assume that $\gamma_e \sqcup \gamma_h$ is independent of $t \in [0, 1]$. For each $\varepsilon > 0$ sufficiently small, we construct an L^t -flat family ($t \in [0, 1]$) of perturbations $(\lambda^{t,\varepsilon}, J^{t,\varepsilon})$ of (λ^t, J^t) which are supported on an ε -neighborhood of $\gamma_e \sqcup \gamma_h$. Moreover, $(\lambda^{t,\varepsilon}, J^{t,\varepsilon})$ converges (uniformly in $t \in [0, 1]$) to (λ^t, J^t) in the C^0 -topology as $\varepsilon \rightarrow 0$. The proof is a 1-parameter version of the construction of L -flat perturbations in [Taubes 2010, Proposition 2.5 and Appendix] and will be omitted.

Claim 4.5.7 *For $\varepsilon > 0$ sufficiently small, $J^{t,\varepsilon}$ is L^t -regular for all $t \in [0, 1]$.*

Proof We may assume that $J^{t,\varepsilon}$ for $t \in [0, 1]$ is a generic 1-parameter family of almost complex structures. Arguing by contradiction, there exist orbit sets γ and γ' and sequences $\varepsilon_j \rightarrow 0$, $t_j \in [0, 1]$ and $u_j: F_j \rightarrow \mathbb{R} \times M$, where:

- (1) u_j is a somewhere-injective J^{t_j,ε_j} -holomorphic curve from γ to γ' .
- (2) γ and γ' are constructed from the nondegenerate orbits of α together with γ_e and γ_h and $\mathcal{A}_{\lambda^{t_j,\varepsilon_j}}(\gamma), \mathcal{A}_{\lambda^{t_j,\varepsilon_j}}(\gamma') < L^{t_j}$.
- (3) u_j is not a connector and $I(u_j) = \text{ind}(u_j) = 0$.

Claim 4.5.8 *After passing to a subsequence, there exists an SFT limit $u_j \rightarrow u_\infty$, where $I(u_\infty) = \text{ind}(u_\infty) = 0$ and u_∞ is not a connector.*

A sketch of Claim 4.5.8 is given in Section 5.2. Since u_∞ is a J^{t_0} -holomorphic curve and J^t is L_t -regular for all $t \in [0, 1]$ by Lemma 4.4.5, we have a contradiction. This implies Claim 4.5.7. \square

Claim 4.5.7 and Lemma 4.5.6 then imply Proposition 4.5.5 for integer coefficients.

By passing to direct limits, we obtain the main result of Morse–Bott theory.

Theorem 4.5.9 *Let α be a nice Morse–Bott form and J a generic almost complex structure adapted to the symplectization of α . Then*

$$\text{ECH}_{\text{MB}}(M, \alpha, J) \simeq \text{ECH}(M).$$

Proof Choose sequences of functions $f_i : M \rightarrow \mathbb{R}$ and constants $L_i \rightarrow +\infty$ which satisfy the hypotheses of Lemmas 4.5.1 and 4.5.4. Then

$$(4-5-1) \quad \text{ECH}(M) = \lim_{i \rightarrow \infty} \text{ECH}^{L_i}(M, f_i \alpha)$$

by Corollary 3.2.3 and

$$(4-5-2) \quad \text{ECC}^{L_i}(M, f_i \alpha, J_i) \simeq \text{ECC}_{\text{MB}}^{L_i}(M, \alpha, J)$$

for all i by Proposition 4.4.7. Also, tautologically,

$$\text{ECC}_{\text{MB}}(M, \alpha, J) = \lim_{i \rightarrow \infty} \text{ECC}_{\text{MB}}^{L_i}(M, \alpha, J).$$

In order to take the direct limit on both sides of (4-5-2) on the level of homology, we need the commutativity of the diagram

$$\begin{array}{ccc} \text{ECC}_{\text{MB}}^{L_i}(M, \alpha) & \xrightarrow{\simeq} & \text{ECH}^{L_i}(M, f_i \alpha) \\ \downarrow & & \downarrow \\ \text{ECC}_{\text{MB}}^{L_{i+1}}(M, \alpha) & \xrightarrow{\simeq} & \text{ECH}^{L_{i+1}}(M, f_{i+1} \alpha) \end{array}$$

for all i , where the rightmost vertical arrow is the natural map defined in Lemma 3.1.7 from interpolating cobordisms. This map coincides with Φ_+ followed by the map induced by the inclusion

$$\text{ECC}^{a_i L_i}(M, f_{i+1} \alpha) \hookrightarrow \text{ECC}^{L_{i+1}}(M, f_{i+1} \alpha).$$

Therefore the diagram commutes by Proposition 4.5.5. \square

5 Topological constraints on holomorphic curves

5.1 The winding number

In this subsection we recall the *winding number* from [Hofer et al. 1995, page 290]: Given a contact manifold (M, ξ) with $\xi = \ker \alpha$, an α -adapted almost complex structure J on $\mathbb{R} \times M$, and a J -holomorphic

curve $u: F \rightarrow \mathbb{R} \times M$ between orbits sets, the winding number $\text{wind}_\pi(u)$ is an algebraic count of the zeros of the section:

$$s: F \rightarrow \text{Hom}_{\mathbb{C}}(TF, u^*\xi).$$

Here s is obtained by composing

$$TF \xrightarrow{u_*} T(\mathbb{R} \times M) \xrightarrow{(\pi_M)_*} TM \xrightarrow{\pi} \xi,$$

where $\pi_M: \mathbb{R} \times M \rightarrow M$ is the projection onto the second factor and π is the projection along the Reeb vector field R_α .

Hofer, Wysocki and Zehnder [Hofer et al. 1995] prove that $\text{wind}_\pi(u)$ is finite. (This is analogous to the elementary complex analysis fact that the number of zeros of a holomorphic function $f: D^2 \subset \mathbb{C} \rightarrow \mathbb{C}$, counted with multiplicities, is equal to the winding number of $f|_{\partial D^2}$.) An immediate corollary is the following lemma:

Lemma 5.1.1 *The map $u_M = \pi_M \circ u$ is transverse to R_α away from a finite number of points on F . In particular, it is an immersion outside a finite number of points on F .*

Throughout the section we will use the notation $u_M = \pi_M \circ u$.

5.2 Blocking lemma

In this subsection we discuss the topological restrictions that a torus foliated by Reeb trajectories imposes on the J -holomorphic curves.

Let α be a contact form on M and $T \subset M$ an oriented torus which is linearly foliated by Reeb trajectories of α . The foliation can either have closed leaves or dense leaves. We denote by $\mathbb{P}^+ H_1(T; \mathbb{R})$ the quotient of $H_1(T; \mathbb{R}) - \{0\}$ by multiplication of positive real numbers. The Reeb flow on T will then have a well-defined “slope” $s \in \mathbb{P}^+ H_1(T; \mathbb{R})$.

Let $\langle \cdot, \cdot \rangle$ be the intersection pairing on $H_1(T; \mathbb{R})$. We then make the following definition:

Definition 5.2.1 If $\delta \in H_1(T; \mathbb{Z})$, then we write $\delta \cdot s > 0$ (resp. $\delta \cdot s = 0$) if $\langle \delta, \gamma \rangle > 0$ (resp. $= 0$) for any representative $\gamma \in H_1(T; \mathbb{R})$ of $s \in \mathbb{P}^+ H_1(T; \mathbb{R})$.

Note that, if $\delta \cdot s = 0$, then δ represents the slope s or $-s$.

Let $T^2 \times [-\varepsilon, \varepsilon]$ be a neighborhood of the Morse–Bott torus $T = T^2 \times \{0\}$ with coordinates (θ, t, y) . We assume that the normal vector to T points in the direction of ∂_y . Let $u: F \rightarrow \mathbb{R} \times M$ be a J -holomorphic curve such that

(C₁) F is a compact Riemann surface with boundary ∂F ; and

(C₂) $u_M(\partial F) \cap (T^2 \times [-\varepsilon, \varepsilon]) = \emptyset$.

Then $u_M(F) \cap T$ only has a finite number of singularities by Lemma 5.1.1 and we denote by $\delta \in H_1(T; \mathbb{Z})$ the homology class of $u_M(F) \cap T$, where the smooth part of $u_M(F) \cap T$ is oriented as the boundary of $u_M(F) \cap (T^2 \times [-\varepsilon, 0])$.

Lemma 5.2.2 (positivity of intersections in dimension three) *Let $T \subset M$ be an oriented torus which is linearly foliated by Reeb trajectories of slope s . If $u: F \rightarrow \mathbb{R} \times M$ is a J -holomorphic curve satisfying (C_1) and (C_2) and $\delta = [u_M(F) \cap T] \in H_1(T; \mathbb{Z})$, then $\delta \cdot s \geq 0$. Moreover, $\delta \cdot s = 0$ if and only if $u_M(F) \cap T = \emptyset$.*

Proof We will prove this lemma in the harder case when T is foliated by orbits of irrational slope, leaving the rational slope case to the reader.

By Lemma 5.1.1, $u_M(F) \cap T$, if nonempty, is the union of a finite set of points and curves which are immersed outside a finite number of singularities.

Assume first that $u_M(F) \cap T$ has a one-dimensional component. By abuse of notation, we do not distinguish between the homology class δ and its representative $u_M(F) \cap T$. A generic finite-length Reeb trajectory γ on T intersects δ in finitely many points away from the singularities and isolated points. In fact, $\delta \cap \gamma = \pi_M(u(F) \cap (\mathbb{R} \times \gamma))$ and $u(F) \cap (\mathbb{R} \times \gamma)$ is a finite set by the intersection theory of holomorphic curves in dimension four; see [Micallef and White 1995, Theorem 7.1]. Since all Reeb trajectories are dense in T , we can choose γ arbitrarily long so that its endpoints are close to each other and far away from δ . Hence we can complete γ to a homologically nontrivial closed curve $\bar{\gamma}$ without introducing extra intersection points with δ . Then the positivity of intersections in dimension four implies that $\delta \cdot [\bar{\gamma}] > 0$. In particular, $\delta \neq 0 \in H_1(T; \mathbb{Z})$. Since we can make the slope of $\bar{\gamma}$ as close as we want to s by taking γ sufficiently long, and s is not an integral homology class, we conclude that $\delta \cdot s > 0$. (Recall that, if $\delta \cdot s = 0$, then δ and either s or $-s$ are parallel.)

Assume now that $u_M(F) \cap T$ is a finite set. We claim that $u_M(F) \cap T = \emptyset$. Suppose that $u_M(F) \cap T \neq \emptyset$ by contradiction. Repeating the construction from the previous paragraph with a finite-length Reeb trajectory γ (resp. γ') which passes through a point in $u_M(F) \cap T$ (resp. is disjoint from $u_M(F) \cap T$), we obtain $\bar{\gamma}$ and $\bar{\gamma}'$. Then $[u(F)] \cdot [\mathbb{R} \times \bar{\gamma}] > 0$ by the positivity of intersections, while $[u(F)] \cdot [\mathbb{R} \times \bar{\gamma}'] = 0$ because they are disjoint. Since $\mathbb{R} \times \bar{\gamma}$ and $\mathbb{R} \times \bar{\gamma}'$ are homologous, we have a contradiction. \square

The following is an immediate consequence of Lemma 5.2.2:

Lemma 5.2.3 (blocking lemma) *Let $T \subset M$ be an oriented torus which is linearly foliated by Reeb trajectories of slope s and let $u: F \rightarrow \mathbb{R} \times M$ be a finite-energy J -holomorphic map, where F is a closed Riemann surface with a finite number of punctures removed. Then:*

- (1) *If u is homotopic, by a compactly supported homotopy, to a map whose image is disjoint from $\mathbb{R} \times T$, then $u_M(F) \cap T = \emptyset$.*

- (2) If T' is a torus which is parallel to and disjoint from T , u has no end that limits to a Reeb orbit that intersects the half-open region between T and T' which includes T' but not T , and the homology class $[u_M(F) \cap T']$ is nonzero and has slope $\pm s$, then u has an end which is asymptotic to a Reeb orbit in T .

We now sketch the proof of Claim 4.5.8.

Sketch of proof of Claim 4.5.8 The consideration that needs slight care is that as $\varepsilon_j \rightarrow 0$, $J^{t_j, \varepsilon_j} \rightarrow J^{t_\infty}$ only in the C^0 -topology. Let $N_{\varepsilon_j}(\gamma_e \sqcup \gamma_h)$ be an ε_j -neighborhood of $\gamma_e \sqcup \gamma_h$ and let $F'_j = u_j^{-1}(\mathbb{R} \times (M - N_{\varepsilon_j}(\gamma_e \sqcup \gamma_h)))$. By the Gromov–Taubes compactness theorem [Taubes 1998], which requires no a priori bound on the genus and is local, there exists a limit u_∞ of $u_j|_{F'_j}$ as currents, after passing to a subsequence. This implies that the homology class $[u_j(F_j)]$ can be taken to be independent of j . The argument from [Hutchings 2002, Theorem 10.1] then gives a bound on the genus of F_j .

We can then either appeal to the C^0 -Gromov compactness theorem of Ivashkovich and Shevchishin [2000] or argue as follows using the blocking lemma. We make the simplifying assumptions that γ and γ' do not contain γ_h and that u_j does not intersect neighborhoods of $\mathbb{R} \times \gamma_h$ and leave the harder general case to the reader.

We claim that $-\chi(F'_j)$ is bounded above. Since we have a genus bound for F_j , it suffices to show that the number $\#\partial F'_j$ of boundary components of F'_j is bounded above. Let $V'_j = N_{\varepsilon_j}(\gamma_e)$ and let $T'_j = \partial V'_j$ with the boundary orientation. Choose an oriented identification $T'_j \simeq \mathbb{R}^2/\mathbb{Z}^2$ such that the meridian has slope 0 and the longitude is determined by the Morse–Bott family and has slope ∞ . We may assume that T'_j is foliated by Reeb orbits of slope $s'_j \gg 0$ and that there exists a torus $T''_j \subset M - V'_j$ which is parallel to T'_j and is foliated by Reeb orbits of rational slope s'' , where s'' is independent of j and $s'_j > s'' > 0$.

Let $V''_j \subset M$ be the solid torus bounded by T''_j and let $F''_j = u_j^{-1}(\mathbb{R} \times (M - V''_j))$. Let $\pi_M : \mathbb{R} \times M \rightarrow M$ be the projection onto the second factor. By Lemma 5.2.2, if C is a component of $\partial F''_j$, then $\pi_M \circ u_j(C) \cdot s' < 0$. Since $[u_j(F_j)]$ is fixed and s'' is rational, $\#\partial F''_j$ must then be bounded above. On the other hand, let $V_j^{(0)} \subset V'_j$ be a sufficiently small neighborhood of γ_e , $T_j^{(0)} = \partial V_j^{(0)}$, and $F_j^{(0)} = u_j^{-1}(\mathbb{R} \times (M - V_j^{(0)}))$. Since $[u_j(F_j)]$ is fixed, $\#\partial F_j^{(0)}$ is also bounded above by the positivity of intersections in dimension four and the asymptotics of u_j near their ends.

To obtain the bound on $\#\partial F'_j$, it then suffices to show that $u_j^{-1}(\mathbb{R} \times (V''_j - V'_j))$ and $u_j^{-1}(\mathbb{R} \times (V'_j - V_j^{(0)}))$ have no disk components D with $\pi_M \circ u_j(\partial D) \subset T'_j$. By Lemma 5.2.2, $\pi_M \circ u_j(\partial D)$ represents a nonzero homology class in T'_j . On the other hand, the inclusion $T^2 \times \{1\} \rightarrow T^2 \times [0, 1]$ induces an isomorphism on homology, which is a contradiction. This proves the bound on $\#\partial F'_j$ and $-\chi(F'_j)$.

We then apply the SFT compactness theorem to $u_j|_{F'_j}$ to obtain $u_\infty : F_\infty \rightarrow \mathbb{R} \times M$. If C is a component of ∂F_∞ , then $u_\infty(C) \subset \gamma_e$, which in turn implies that u_∞ is a constant. Hence $\partial F_\infty = \emptyset$. The punctures of F_∞ are either removable or limit to orbits in γ and γ' . Finally, since $[u_j(F_j)]$ is not the class given by a connector, u_∞ is also not a connector. □

5.3 Trapping lemma

In this subsection we analyze some topological restrictions on J -holomorphic curves with ends at a Morse–Bott torus.

We fix coordinates (θ, t, y) on a neighborhood $T^2 \times [-\varepsilon, \varepsilon]$ of a torus $T = T^2 \times \{0\}$ and consider contact forms of the type $\alpha = g(\theta, t, y) d\theta + f(\theta, t, y) dt$ such that:

- $f(\partial_y g) - (\partial_y f)g > 0$.
- $f|_{y=0} = 1$.
- $\partial_\theta f|_{y=0} = \partial_t f|_{y=0} = \partial_y f|_{y=0} = 0$.
- $\partial_\theta g|_{y=0} = \partial_t g|_{y=0} = 0$ and $\partial_y g|_{y=0} = 1$.
- $\partial_y^2 f|_{y=0} \neq 0$.

These conditions imply that T is a Morse–Bott torus and that the Reeb vector field R is given by ∂_t on T .

We recall that the asymptotic operator of a closed Reeb orbit γ describes the action of the linearized Reeb flow on sections of the (pullback of the) contact structure $\gamma^*\xi$ along the orbit. More precisely, the linearized Reeb flow gives a symplectic connection ∇^R for $\gamma^*\xi$ and the asymptotic operator is $J\nabla^R$, where J is an almost complex structure on ξ ; see [Hofer et al. 1996] for more details on the asymptotic operator and Section 4.1 for the linearized Reeb vector field.

If we choose a generic almost complex structure J adapted to the symplectization of α such that $\partial_t J|_{y=0} = 0$, then there is a unitary trivialization of ξ along T such that the asymptotic operator of an end of a holomorphic map converging to a Reeb orbit on T has the form

$$(5-3-1) \quad A = -J_0 \frac{d}{dt} + J_0 \begin{pmatrix} 0 & 0 \\ a & 0 \end{pmatrix},$$

where $a > 0$ if T is a positive Morse–Bott torus, $a < 0$ if T is a negative Morse–Bott torus, and $J_0 = \begin{pmatrix} 0 & -1 \\ 1 & 0 \end{pmatrix}$. This unitary trivialization is obtained by projecting $(\partial_y, \partial_\theta)$ to ξ along ∂_t .

Lemma 5.3.1 *The eigenvalues of the asymptotic operator A are $\lambda_0 = 0$, $\lambda_a = -a$, and λ_n and λ_{-n} for $n \in \mathbb{N}$, which are the positive and the negative solutions of the equation $\lambda(\lambda + a) = n^2$. The eigenfunctions that correspond to the eigenvalues λ_0 and λ_a are*

$$f_0(t) = \begin{pmatrix} 0 \\ 1 \end{pmatrix} \quad \text{and} \quad f_a(t) = \begin{pmatrix} 1 \\ 0 \end{pmatrix}.$$

The eigenvalues $\lambda_{\pm n}$ for $n \geq 1$ are degenerate with multiplicity 2 and their eigenfunctions have winding number $\pm n$.

Proof The asymptotic operator is sufficiently simple that we can determine its spectrum by an explicit computation: The eigenfunctions ξ of A are the 2π -periodic solutions of the differential equation

$$(5-3-2) \quad \dot{\xi} = \begin{pmatrix} 0 & -\lambda \\ \lambda + a & 0 \end{pmatrix} \xi.$$

If $\lambda = 0$ or $\lambda = -a$, which are the only cases when the matrix in (5-3-2) cannot be diagonalized, the eigenfunctions are

$$f_0(t) = \begin{pmatrix} 0 \\ 1 \end{pmatrix} \quad \text{and} \quad f_a(t) = \begin{pmatrix} 1 \\ 0 \end{pmatrix}.$$

If $\lambda(\lambda + a) < 0$, then (5-3-2) can be diagonalized over the real numbers, and it is easy to see that it has no periodic solutions. If $\lambda(\lambda + a) > 0$ a direct computation shows that solutions of (5-3-2) are of the form $\xi(t) = \Phi_\lambda(t)\xi_0$, where

$$\Phi_\lambda(t) = \begin{pmatrix} \cos(\sqrt{\lambda(\lambda + a)}t) & -\frac{\lambda}{\sqrt{\lambda(\lambda + a)}} \sin(\sqrt{\lambda(\lambda + a)}t) \\ \frac{\lambda + a}{\sqrt{\lambda(\lambda + a)}} \sin(\sqrt{\lambda(\lambda + a)}t) & \cos(\sqrt{\lambda(\lambda + a)}t) \end{pmatrix}.$$

Then $\Phi_\lambda(2\pi)$ has eigenvalue 1 if and only if $\lambda(\lambda + a) = n^2 \in \mathbb{N}$, in which case $\Phi_\lambda(2\pi)$ is the identity. \square

If u is a J -holomorphic map with an end \mathcal{E} which is asymptotic to a Morse–Bott torus T , we say that \mathcal{E} is *one-sided* if its projection to M does not intersect T .

Lemma 5.3.2 (trapping lemma) *Let α be a contact form, T an α -Morse–Bott torus, and \mathcal{E} a one-sided end of a J -holomorphic map which is asymptotic to a Reeb orbit in T . If T is positive (resp. negative), then \mathcal{E} is a positive (resp. negative) end.*

Proof Suppose T is positive. By [Hofer et al. 1996, Theorem 1.3], a positive (resp. negative) end \mathcal{E} of a J -holomorphic curve approaches a Reeb orbit of T along an eigenfunction of the asymptotic operator with negative (resp. positive) eigenvalue. By Lemma 5.3.1, the eigenfunction has a nonpositive eigenvalue if and only if it has nonpositive winding number. On the other hand, if \mathcal{E} is one-sided, then the asymptotic eigenfunction must have winding number zero. Hence \mathcal{E} must be a positive end. The case for T negative is similar. \square

6 Construction of contact forms

In this section we construct some contact forms on $T^2 \times [1, 2]$ and $D^2 \times S^1$ which will be used in the proof of the main theorem.

6.1 Contact forms on $T^2 \times [1, 2]$

Let (ϑ, t, y) be coordinates on

$$T^2 \times [1, 2] \simeq (\mathbb{R}^2/\mathbb{Z}^2) \times [1, 2].$$

Slopes of essential curves on T^2 will be measured with respect to (ϑ, t) , ie with respect to the basis of $H_1(T^2)$ given by the homology classes of the curves $\vartheta \mapsto (\vartheta, *)$ and $t \mapsto (*, t)$. Let

$$(6-1-1) \quad \alpha_{f,g} = g(y) d\vartheta + f(y) dt$$

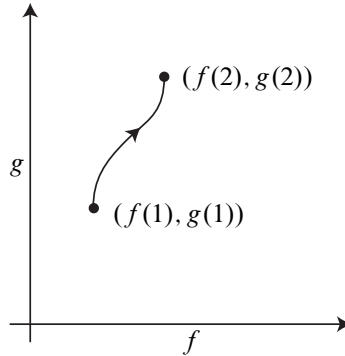
Figure 1: Trajectory of $(f_\delta(y), g_\delta(y))$.

be a contact form on $T^2 \times [1, 2]$, where f and g are functions on $[1, 2]$. We write $f' = df/dy$ and $g' = dg/dy$.

The following is a straightforward calculation:

Lemma 6.1.1 *The form $\alpha_{f,g}$ is a contact form if and only if*

$$(6-1-2) \quad fg' - f'g > 0.$$

The kernel $\ker \alpha_{f,g}$ is spanned by $\{\partial_y, -f\partial_\vartheta + g\partial_t\}$. Assuming $\alpha_{f,g}$ is a contact form, the Reeb vector field is given by

$$(6-1-3) \quad R_{\alpha_{f,g}} = \frac{1}{fg' - g'f}(-f'\partial_\vartheta + g'\partial_t).$$

In words, equation (6-1-2) says that the curve in \mathbb{R}^2 parametrized by (f, g) is transverse to the radial rays and rotates in the counterclockwise direction.

Later in the article will need the following family of contact forms on $T^2 \times [1, 2]$:

Example 6.1.2 Given a (small) positive irrational parameter δ we consider pairs of functions (f_δ, g_δ) such that the following hold (see Figure 1):

- (1) (f_δ, g_δ) satisfies (6-1-2).
- (2) $0 \leq f'_\delta(y)/g'_\delta(y) \leq \delta$; $f'_\delta(y)/g'_\delta(y)$ is increasing on $(1, \frac{3}{2})$ and is decreasing on $(\frac{3}{2}, 2)$, and is equal to δ at $y = \frac{3}{2}$.
- (3) $(f_\delta(y), g_\delta(y)) = (f_\delta(1) + (y-1)^2, g_\delta(1) + (y-1))$ near $y = 1$.
- (4) $(f_\delta(y), g_\delta(y)) = (f_\delta(2) - c_\delta(y-2)^2, g_\delta(2) + c_\delta(y-2))$ near $y = 2$.
- (5) $(f_\delta(1), f_\delta(1))$ is independent of δ and all the $(f_\delta(2), f_\delta(2))$ lie on the same line through the origin.
- (6) The constants c_δ are chosen so that any two contact forms α_δ and $\alpha_{\delta'}$ are constant multiples of one another near $y = 2$.

The contact form $\alpha_{f_\delta, g_\delta}$ will also be called α_δ . Its Reeb vector field R_{α_δ} has Morse–Bott tori whose Reeb orbits have rational slope in the interval $[-\infty, -1/\delta]$; each rational slope occurs twice, once on the interval $[1, \frac{3}{2}]$ and once on the interval $[\frac{3}{2}, 2]$. Note that the Reeb orbits in the two Morse–Bott tori of infinite slope have parallel directions and are in “elimination position”, ie assuming that (f_δ, g_δ) is extended slightly to $T^2 \times [1 - \varepsilon, 2 + \varepsilon]$ so that the Reeb orbits have positive slope on $y \in [1 - \varepsilon, 1) \cup (2, 2 + \varepsilon]$, one could deform the pair (f_δ, g_δ) relative to $\{y = 1 - \varepsilon, 2 + \varepsilon\}$ to make the slope of the Reeb vector field always positive; during the deformation we would see the two Morse–Bott tori of infinite slope coming close to each other and finally canceling. Also, by taking δ to be sufficiently small, all the Reeb orbits in $\text{int}(T^2 \times [1, 2])$ can be made to have arbitrarily large action.

6.2 Contact forms on $D^2 \times S^1$

Let (ρ, ϕ, θ) be cylindrical coordinates⁵ on the solid torus

$$D^2 \times S^1 = \{\rho \leq 1\} \times (\mathbb{R}/2\pi\mathbb{Z}).$$

Let $T_{\bar{\rho}} = \{\rho = \bar{\rho}\} \subset D^2 \times S^1$ for $\bar{\rho} \in (0, 1]$.

Convention 6.2.1 Slopes of essential curves on the torus $T_{\bar{\rho}}$ are measured with respect to (θ, ϕ) instead of (ϕ, θ) .

We consider contact forms which can be written as

$$(6-2-1) \quad \alpha_{f,g} = g(\rho) d\theta + f(\rho) d\phi.$$

Here we need to choose $(f(\rho), g(\rho))$ so that $\alpha_{f,g}$ is smooth on all of $D^2 \times S^1$, which means that $f(0) = 0$ and the derivatives of odd degree of both f and g at $\rho = 0$ vanish. We write $f' = df/d\rho$ and $g' = dg/d\rho$. The analog of Lemma 6.1.1 is the following:

Lemma 6.2.2 *The form $\alpha_{f,g}$ is a contact form if and only if*

$$(6-2-2) \quad f'g - fg' > 0 \quad \text{for } \rho > 0, \text{ and}$$

$$(6-2-3) \quad \lim_{\rho \rightarrow 0} \frac{f'g - fg'}{\rho} > 0.$$

The kernel $\ker \alpha_{f,g}$ is spanned by $\{\partial_\rho, -f\partial_\theta + g\partial_\phi\}$. Assuming $\alpha_{f,g}$ is a contact form, the Reeb vector field is given by

$$(6-2-4) \quad R_{\alpha_{f,g}} = \frac{1}{f'g - fg'} (f'\partial_\theta - g'\partial_\phi).$$

In particular, $R_{\alpha_{f,g}}$ is parallel to ∂_θ at $\rho = 0$.

Each torus $T_{\bar{\rho}}$ is linearly foliated by the Reeb flow of $\alpha_{f,g}$.

⁵We are making a distinction between the symbols ϑ and θ .

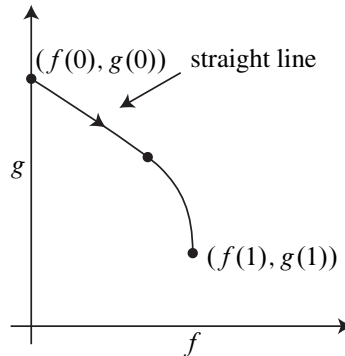

Figure 2: Trajectory of $(f(\rho), g(\rho))$. Here the arrow points in the positive ρ -direction.

Since they will be useful later, we present a pair of constructions of contact forms on $D^2 \times S^1$ of the form given in (6-2-1).

Example 6.2.3 Given $\nu > 0$ and $C > 1$, let $(f(\rho), g(\rho)) = (\nu\rho^2, C - \rho^2)$. This gives a smooth contact form on $D^2 \times S^1$ and the Reeb vector field on T_ρ has slope $-g'/f' = 1/\nu$ for all $\rho > 0$. In particular, if ν is irrational, then the only simple closed orbit of $R_{\alpha_{f,g}}$ is the core curve $\{\rho = 0\}$.

Example 6.2.4 The following contact forms, which generalize those in Example 6.2.3, will be used later in the paper. We define α on $D^2 \times S^1$ so that the following hold:

- (1) (f, g) satisfies (6-2-2).
- (2) $(f(\rho), g(\rho)) = (\rho^2, C - \rho^2)$ near $\rho = 0$, where $C > 0$ is a large constant.
- (3) $(f(\rho), g(\rho)) = (f(1) - (\rho - 1)^2, g(1) - (\rho - 1))$ near $\rho = 1$.⁶
- (4) $-g'/f'$ monotonically increases from 1 to $+\infty$ as ρ goes from 0 to 1.

The profile of the functions (f, g) is shown in Figure 2.

On each torus $T_\rho \subset D^2 \times S^1$, the Reeb vector field R_α gives a foliation by Reeb orbits of slope r in the interval $[1, \infty]$, where there is a unique ρ for each slope $r \in (1, \infty]$.

7 ECH for manifolds with torus boundary

In this section we define several ECH groups on a compact manifold M with torus boundary $T = \partial M$. We fix an oriented identification $T \simeq \mathbb{R}^2/\mathbb{Z}^2$ so that we can refer to slopes of essential curves on T . Let α be a contact form on M such that T is foliated by Reeb orbits of slope r . If r is rational, we assume that T is Morse–Bott. All ECH groups on M and $\text{int}(M)$ are computed using a C^∞ -small perturbation

⁶Here $(f, g)|_{\rho=1} = (f_\delta, g_\delta)|_{y=2}$. This allows us to extend α_δ to $D^2 \times S^1$ for all sufficiently small $\delta > 0$ by writing (f_δ, g_δ) as a suitable constant multiple of $(f_{\delta_0}, g_{\delta_0})$. This is possible because of condition (6) in the definition of α_δ . Observe that the Reeb orbits of α_δ and α_{δ_0} agree on V , modulo parametrization.

of α so that all Reeb orbits in $\text{int}(M)$ are nondegenerate. Let J be a Morse–Bott regular almost complex structure on $\mathbb{R} \times M$ adapted to α .

7.1 Definitions

We introduce several ECH groups:

(1) **ECH(int(M), α)** The ECH chain group $\text{ECC}(\text{int}(M), \alpha)$ is generated by orbit sets whose simple orbits lie in the interior of M . In particular, we are discarding the Morse–Bott family of orbits on T if r is rational. The differential ∂ is the usual one, ie it counts holomorphic curves of ECH index $I(\gamma, \gamma', Z) = 1$ in $\mathbb{R} \times \text{int}(M)$ whose connector components are trivial cylinders. Since $\text{int}(M)$ is not closed, we need to verify that $\text{ECC}(\text{int}(M), \alpha)$ is indeed a chain complex.

Lemma 7.1.1 ∂ is defined and $\partial^2 = 0$.

Proof We claim that the SFT compactness theorem holds in $\mathbb{R} \times \text{int}(M)$. This implies that the arguments used in [Hutchings and Taubes 2007; 2009a] to prove $\partial^2 = 0$ will then carry over to our setting. Let u_n be a sequence of J -holomorphic maps with image in $\mathbb{R} \times \text{int}(M)$. After passing to a subsequence, u_n converges to a building u_∞ such that all its components have image in $\mathbb{R} \times M$. By the blocking lemma, no component of u_∞ can intersect ∂M .

We claim that no component of u_∞ can have an end at a Reeb orbit in ∂M : indeed, if there is a component with a positive (resp. negative) end at a Reeb orbit in ∂M , then there is another component of u_∞ with a negative (resp. positive) end at a Reeb orbit in ∂M . By the trapping lemma, this is impossible if the image of u_∞ is contained in $\mathbb{R} \times M$. □

(2a) **ECH(M , α) for r irrational** This is defined to be $\text{ECH}(\text{int}(M), \alpha)$.

(2b) **ECH(M , α) for r rational** Let \mathcal{N} be the set of simple Reeb orbits on T . The set \mathcal{N} comes with distinguished orbits e, h which become elliptic and hyperbolic after a suitable perturbation. Writing \mathcal{P} for the set of simple orbits in $\text{int}(M)$, $\text{ECC}(M, \alpha)$ is the chain complex which is generated by orbit sets constructed from $\mathcal{P} \cup \{h, e\}$ and whose differential counts Morse–Bott buildings of ECH index 1 in $\mathbb{R} \times M$.

Lemma 7.1.2 If α is nondegenerate on $\text{int}(M)$, then it is nice.

Proof Suppose that ∂M is a negative Morse–Bott torus; the positive case is analogous. Let \mathcal{N} be the Morse–Bott family corresponding to ∂M . If α is not nice, then there is a Morse–Bott building \tilde{u} in $\mathbb{R} \times M$ with ECH index $I(\tilde{u}) = 1$ whose holomorphic part u has more than one nonconnector irreducible component. Assume that there are exactly two nonconnector components u_1 and u_2 (this is mostly to simplify notation; the general case is treated in the same way). By the trapping lemma, the only ends of u_1 and u_2 that limit to ∂M are negative ends. We form the Morse–Bott buildings \tilde{u}_1 and \tilde{u}_2 by augmenting the ends of u_1 and u_2 at ∂M with gradient flow lines and denote the union of these two buildings by \tilde{u}' .

We claim that $I(\tilde{u}) = I(\tilde{u}')$. Indeed, all the ends of u_1 and u_2 that limit to orbits on ∂M are connected to critical points in \mathcal{N} by gradient flow lines, with possible interruptions by connectors. Hence \tilde{u} and \tilde{u}' have the same ends in the ECH sense and define the same relative homology class. This implies that $I(\tilde{u}) = I(\tilde{u}')$.

On the other hand, let u_i for $i = 1, 2$ be a k_i th cover of a J -holomorphic curve v_i , and define very nice, simply covered buildings \tilde{v}_i . By Theorem 4.4.3(2), we can perturb \tilde{v}_1 and \tilde{v}_2 to J_ϵ -holomorphic maps $v_{1,\epsilon}$ and $v_{2,\epsilon}$, respectively. We denote by $v_{i,\epsilon}^{k_i}$ the J_ϵ -holomorphic map made of k_i parallel copies of $v_{i,\epsilon}$. Then, by [Hutchings 2009, Theorem 5.1],

$$I(\tilde{u}) \geq I(v_{1,\epsilon}^{k_1}) + I(v_{2,\epsilon}^{k_2}) \geq k_1 I(v_{1,\epsilon}) + k_2 I(v_{2,\epsilon}).$$

Since $I(v_{i,\epsilon}) > 0$ for $i = 1, 2$, this is a contradiction. \square

Lemma 7.1.2 implies that $\partial^2 = 0$, since it guarantees that the Morse–Bott gluing is done at a different end from the gluing of connectors (ie the obstruction bundle gluing of Hutchings and Taubes [2007; 2009a]) and the two kinds of gluing can be done independently.

(3) **ECH^b(M, α)** The chain complex $\text{ECC}^b(M, \alpha)$ is generated by orbit sets which are constructed from $\mathcal{P} \cup \{e\}$. As in the case of $\text{ECC}(M, \alpha)$, if \mathcal{N} is a negative Morse–Bott family, no Morse–Bott building \tilde{u} in $\mathbb{R} \times M$ besides trivial cylinders can have e at the positive end. Hence the differential can be defined by counting Morse–Bott buildings of ECH index 1 in $\mathbb{R} \times M$, whose orbit sets are constructed from $\mathcal{P} \cup \{e\}$.

The verification of $\partial^2 = 0$ needs one extra consideration: an index 2 family of J -holomorphic curves in $\mathbb{R} \times M$ can break into a Morse–Bott building \tilde{u} which involves h at the negative end, followed by a holomorphic cylinder from h to e . (Note that, by the trapping lemma, these holomorphic cylinders are the only nontrivial holomorphic curves which go from h to e and so there are no other cases to consider.)

This type of breaking could be a problem because orbit sets containing h are not in the chain complex $\text{ECC}^b(M, \alpha)$. However, since there are *two* gradient trajectories from h to e with ECH index $I = 1$ and no other holomorphic curve (or building) with a positive end at h , the Morse–Bott building \tilde{u} can be glued onto each of the two gradient trajectories. This proves that families breaking at h always come in pairs, and therefore $\partial^2 = 0$ holds even when we discard orbit sets which contain h .

If \mathcal{N} is a positive Morse–Bott family, then e can only be at the positive end of a J -holomorphic curve in $\mathbb{R} \times M$, and the proof of $\partial^2 = 0$ remains the same with the obvious modifications.

(4) **ECH^{\sharp}(M, α)** The chain complex $\text{ECC}^\sharp(M, \alpha)$ is generated by orbit sets which are constructed from $\mathcal{P} \cup \{h\}$, and its differential counts ECH index 1 Morse–Bott buildings which are asymptotic to orbit sets constructed from $\mathcal{P} \cup \{h\}$.

Remark 7.1.3 The differentials of the ECH groups defined in this section preserve the total homology class of the generators. Then we can define subgroups $\text{ECH}(M, \alpha, A)$ for every $A \in H_1(M)$. Similar notation will be used for the variants of this group.

7.2 Well-definition

In this subsection we prove that $\text{ECH}(M, \alpha)$ is independent of the choice of α , provided the slope r is irrational. The verification in the other cases will be omitted; we will be careful to use the invariance of ECH groups for manifolds with torus boundary only in the case where it is proved. The main result proved in this subsection is the following:

Proposition 7.2.1 *Let α_1 and α_2 be contact forms on M which agree on ∂M to first order (and in particular the Reeb vector fields and the characteristic foliations of α_1 and α_2 at ∂M are equal) and define contact structures $\xi_i = \ker \alpha_i$ which are isotopic relative to the boundary. If ∂M is foliated by Reeb orbits of irrational slope, then there is an isomorphism*

$$\text{ECH}(M, \alpha_1) \simeq \text{ECH}(M, \alpha_2).$$

The strategy of the proof is to extend (M, α_i) for $i = 1, 2$ to closed contact manifolds and to use the invariance of ECH for closed manifolds. Lemma 7.2.3 constructs the contact forms which are used to extend (M, α_i) . Then Lemma 7.2.6 shows that, up to some action L , the ECH groups of (M, α_i) are isomorphic to the ECH groups of their extension. Finally, Lemmas 7.2.7, 7.2.9 and 7.2.10 establish some compatibility properties for the continuation maps between the extended forms, so that the proposition can finally be proved by a direct limit argument.

Lemma 7.2.2 *Let $\alpha = g(\rho) d\theta + f(\rho) d\phi$ be a contact form on $D^2 \times S^1$ with cylindrical coordinates (ρ, ϕ, θ) . Write $v(\rho) = (f(\rho), g(\rho))$ and let $|v(\rho)|$ be the norm of $v(\rho)$ and $\zeta(\rho)$ the angle between $v(\rho)$ and $v'(\rho)$, both measured with respect to the standard Euclidean structure on \mathbb{R}^2 . Then, if the torus T_ρ is foliated by closed Reeb orbits, for every Reeb orbit γ on T_ρ we have*

$$(7-2-1) \quad \mathcal{A}(\gamma) \geq |v(\rho)| |\sin \zeta(\rho)|.$$

Proof Let J be the standard complex structure, \cdot the standard inner product, and $|\cdot|$ the standard Euclidean norm on \mathbb{R}^2 . For every $\rho \in (0, 1]$ we trivialize the tangent bundle of the torus T_ρ by $(\partial_\phi, \partial_\theta)$ and measure the slope of curves on T_ρ with respect to (ϕ, θ) .⁷

By Lemma 6.2.2, R is tangent to T_ρ for all $\rho \in (0, 1]$ and can be written as

$$R = \frac{(-g', f')}{(-g', f') \cdot (f, g)},$$

with respect to $(\partial_\phi, \partial_\theta)$. If we write $v = (f, g)$, then $Jv' = (-g', f')$ and

$$|R| = \left| \frac{(-g', f')}{(-g', f') \cdot (f, g)} \right| = \left| \frac{Jv'}{Jv' \cdot v} \right| = \frac{1}{|v| |\sin \zeta|},$$

⁷In the proof we are using a different convention from that of Convention 6.2.1.

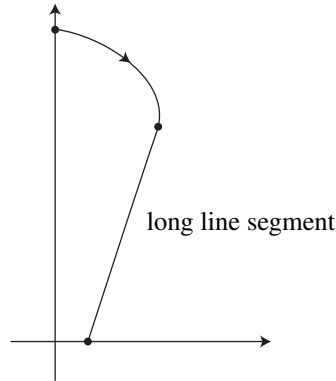

Figure 3: Trajectory of $(f(\rho), g(\rho))$. The arrow is in the direction of increasing ρ .

where $\zeta(\rho)$ is the angle between $v(\rho)$ and $v'(\rho)$. Note that $\text{slope}(R) = \text{slope}(Jv') = -f'/g'$.

Let $\rho \in (0, 1)$ be such that R has rational slope on T_ρ and let w be the shortest integer vector with that slope. Then T_ρ is foliated by Reeb orbits and each Reeb orbit γ has action $\mathcal{A}(\gamma) = |w|/|R|$. Since $|w| \geq 1$, we have the bound

$$\mathcal{A}(\gamma) \geq \frac{1}{|R|} = |v| |\sin \zeta|. \quad \square$$

Lemma 7.2.3 *Given $L > 0$ and $r > 0$ irrational, there is a contact form $\alpha(r, L) = g(\rho) d\theta + f(\rho) d\phi$ on $V = D^2 \times S^1$ with cylindrical coordinates (ρ, ϕ, θ) such that*

- (a) *on ∂V , the Reeb vector field R of $\alpha(r, L)$ has slope $-1/r$ and the characteristic foliation has infinite slope; and*
- (b) *all the closed orbits of R have $\alpha(r, L)$ -action larger than L .*

Proof We describe $\alpha(r, L)$ by describing the vector $v(\rho) = (f(\rho), g(\rho))$. We construct $v(\rho) = (f(\rho), g(\rho))$ “backwards”, starting with larger ρ , subject to the condition $d|v|/d\rho < 0$. The profile of $v(\rho)$ is given in Figure 3.

(1) For $\rho \in [\frac{3}{4}, 1]$, define $v(\rho)$ so that it parametrizes a “long”⁸ segment and R is constant, has slope $-1/r$, and satisfies $|R| = 1/K$. Since r is irrational, there are no Reeb orbits on T_ρ for $\rho \in [\frac{3}{4}, 1]$.

(2) Fix an irrational slope $-1/r' > -1/r$ such that all integer vectors with slope between $-1/r'$ and $-1/r$ have norm greater than $2L/K$. For $\rho \in [\frac{1}{2}, \frac{3}{4}]$, define $v(\rho)$ so that $|R(\rho)| < 2/K$ and $\text{slope}(R) = \text{slope}(Jv')$ decreases monotonically from $-1/r'$ to $-1/r$ as ρ increases. One can achieve this by making $v(\rho)$ vary sufficiently slowly for $\rho \in [\frac{1}{2}, \frac{3}{4}]$. Hence, if γ is a Reeb orbit of T_ρ with $\rho \in [\frac{1}{2}, \frac{3}{4}]$, then

$$\mathcal{A}(\gamma) \geq \frac{K}{2} \frac{2L}{K} = L.$$

⁸The segment is chosen so that (7-2-2) from (2) is satisfied.

Let $\bar{\zeta}$ be the clockwise angle from a line of slope $-1/r'$ to a line of slope $-1/r$. By taking the “long” segment to be sufficiently long, we may assume that

$$(7-2-2) \quad |\sin \bar{\zeta}| > KL |\sin(\zeta(\frac{3}{4}))|.$$

(3) For $\rho \in [\frac{1}{4}, \frac{1}{2}]$, define $v(\rho)$ so that $\text{slope}(Jv')$ decreases monotonically from $1/r'' > 0$ to $-1/r'$ as ρ increases and $|\sin \zeta(\rho)| \geq |\sin \bar{\zeta}|$. We can achieve these properties by changing $v(\rho)$ slowly with respect to the slope of $v'(\rho)$. Then, by (7-2-1) and (7-2-2),

$$(7-2-3) \quad \mathcal{A}(\gamma) \geq |v(\rho)| \cdot KL |\sin(\zeta(\frac{3}{4}))| \geq KL |v(\frac{3}{4})| \cdot |\sin(\zeta(\frac{3}{4}))| \geq KL \frac{1}{K} = L,$$

where γ is a Reeb orbit of T_ρ , $\rho \in [\frac{1}{4}, \frac{1}{2}]$.

(4) Finally, define $v(\rho)$ for $\rho \in [0, \frac{1}{4}]$ which parametrizes a segment of slope $1/r''$ and satisfies $f(0) = 0$. $\mathcal{A}(\gamma) \geq L$ follows from (7-2-3). □

Remark 7.2.4 We will always assume that, when $L_0 < L_1$, each radial ray in the fg -plane intersects the curve $(f_0(\rho), g_0(\rho))$ defining $\alpha(r, L_0)$ before or at the same time as the curve $(f_1(\rho), g_1(\rho))$ defining $\alpha(r, L_1)$. Then there exist a diffeomorphism $\sigma : D^2 \times S^1 \rightarrow D^2 \times S^1$ such that $\sigma(\rho, \phi, \theta) = (\sigma_0(\rho), \phi, \theta)$ and a function $h : [0, 1] \rightarrow \mathbb{R}^{\geq 0}$ such that $\alpha(r, L_1) = e^{h(\rho)} \sigma^*(r, \alpha(L_0))$.

Let (M, α_i) for $i = 1, 2$ be contact manifolds as in Proposition 7.2.1. We can choose coordinates $(\vartheta, t, y) \in (\mathbb{R}^2/\mathbb{Z}^2) \times [-\varepsilon, 0]$ on a small collar of ∂M such that ∂M corresponds to $T^2 \times \{0\}$ and the contact forms α_i can be written as

$$\alpha_i = g_i(\vartheta, t, y) d\vartheta + f_i(\vartheta, t, y) dt$$

with $\partial f_i / \partial \vartheta = \partial f_i / \partial t = \partial g_i / \partial \vartheta = \partial g_i / \partial t = 0$ at $t = 0$ (ie along ∂M). Note that we have used the assumption that α_1 and α_2 coincide to first order along ∂M to conclude that they can be put in this form with the same choice of coordinates. Moreover, we assume that these coordinates have been chosen so that, on ∂M , the Reeb vector fields of α_1 and α_2 have *negative irrational* slope $-r$ and that the slopes of the characteristic foliations of $\xi_i = \ker \alpha_i$ are nonnegative and sufficiently close to zero.⁹ Here the slope is measured with respect to (ϑ, t) .

For $L' > 0$ sufficiently large, we embed (M, α_i) into a closed contact manifold $(M', \alpha'_i(L'))$ such that

- (1) $M' = M \cup V$, where ∂M and ∂V are glued by the identifications $\rho = 1 - y$, $\phi = 2\pi t$ and $\theta = 2\pi \vartheta$; and
- (2) $\alpha'_i(L')|_M = \alpha_i$ and $\alpha'_i(L')|_V$ is a C^1 -small perturbation of $\alpha(r, L')$ near the boundary.

If the perturbation of the form $\alpha(r, L')$ is small enough in the C^1 -topology, it does not create any closed Reeb orbit of action less than L' . Since the size of the perturbation which is necessary to glue α_i with

⁹Close enough that Claim 7.2.5 applies.

$\alpha(r, L')$ essentially depends on the slope of the characteristic foliation of α_i on ∂M , we can claim the following:

Claim 7.2.5 *All closed Reeb orbits of $(M', \alpha_i(L'))$ of action less than L' are contained in M .*

The next lemma identifies some ECH groups for (M, α_i) with ECH groups for $(M', \alpha'_i(L'))$.

Lemma 7.2.6 *For all $L \leq L'$, if we choose the almost complex structure on the symplectization of $(M', \alpha'_i(L'))$ to extend the almost complex structure picked on the symplectization of (M, α_i) , then there are isomorphisms*

$$\text{ECC}^L(M, \alpha_i) \simeq \text{ECC}^L(M', \alpha'_i(L'))$$

of chain complexes.

Proof By Lemma 7.2.3, there is an isomorphism

$$\text{ECC}^L(M, \alpha_i) \simeq \text{ECC}^L(M', \alpha'_i(L'))$$

as vector spaces. To prove that the isomorphism holds as chain complexes, it suffices to show that every holomorphic curve in $\mathbb{R} \times M'$ which is positively asymptotic to an orbit set of $R_{\alpha'_i(L')}$ of $\alpha'_i(L')$ -action less than L (which is equal to an orbit set of R_{α_i} of α_i -action less than L) has image in $\mathbb{R} \times M$. Let u be a holomorphic map in $\mathbb{R} \times M'$ connecting the orbit set γ of R_{α_i} in M with $\mathcal{A}_{\alpha_i}(\gamma) < L$ to the orbit set γ' of $R_{\alpha'_i(L')}$ in M' . Since $\mathcal{A}_{\alpha_i}(\gamma) < L$, γ' must be contained in M . Hence the homology class of $u_{M'} \cap \partial V$ in $H_1(\partial V)$ is a multiple of the class of the meridian of V . On the other hand, inside V there is a concentric torus V' on which the Reeb orbits are meridians. (This torus corresponds to the vertical tangency of the curve in Figure 3.) Then Lemma 5.2.3 (blocking lemma) implies that u must be asymptotic to some orbits in V' . This is not possible since all the ends of u limit to orbits of action less than L . Hence the image of u is contained in $\mathbb{R} \times M$ by Lemma 5.2.3(1). \square

The induced identification

$$\text{ECH}^L(M, \alpha_i) \simeq \text{ECH}^L(M', \alpha'_i(L'))$$

is independent of L' in the following sense: Let $L \leq L_0 \leq L_1$ be positive numbers such that no Reeb orbit in (M, α_i) (for either $i = 1$ or $i = 2$) has action L . By Remark 7.2.4 and Lemma 3.1.7, there are maps

$$\Psi_i^{L, L_0, L_1}: \text{ECH}^L(M', \alpha'_i(L_1)) \rightarrow \text{ECH}^L(M', \alpha'_i(L_0))$$

induced by interpolating cobordisms (W, μ_i) from $(M', \alpha'_i(L_1))$ at the positive end to $(M', \alpha'_i(L_0))$ at the negative end. Then we have the following:

Lemma 7.2.7 *The maps Ψ_i^{L, L_0, L_1} restrict to the identity on $\text{ECH}^L(M, \alpha_i)$.*

Proof The cobordism W is topologically trivial, ie $W \simeq [0, 1] \times M'$, and we can assume that (W, μ_i) restricts to a piece of symplectization on $[0, 1] \times M$. We choose the almost complex structure J to be \mathbb{R} -invariant on $\mathbb{R} \times M$. As before, all orbit sets of $\alpha'_i(L_j)$ -action less than L for $j = 0, 1$ are contained

in M . Then the blocking lemma¹⁰ and the argument of Lemma 7.2.6 imply that all J -holomorphic maps between orbit sets of action less than L are contained in $\mathbb{R} \times M$. If those J -holomorphic maps have ECH index zero, then they are branched covers of trivial cylinders because $([0, 1] \times M, \mu_i|_{[0,1] \times M})$ is a piece of symplectization. Hence the map induced on $\text{ECH}^L(M, \alpha)$ is the identity by Theorem 3.1.2(i). \square

We will use the identifications $\text{ECH}^L(M, \alpha_i) \simeq \text{ECH}^L(M', \alpha'_i(L'))$ to define a map

$$\Phi : \text{ECH}(M, \alpha_1) \rightarrow \text{ECH}(M, \alpha_2).$$

This involves two steps: the construction of maps

$$\Phi_L : \text{ECH}^L(M, \alpha_1) \rightarrow \text{ECH}^{\kappa L}(M, \alpha_2)$$

for some $\kappa > 1$ and the taking of direct limits.

Let $f : M \rightarrow \mathbb{R}$ be a smooth positive function such that $\phi^*(\alpha_2) = f\alpha_1$ for some diffeomorphism ϕ of M which is isotopic to the identity and restricts to the identity on ∂M . Then choose $\kappa > 1$ such that $1/\kappa \leq f \leq \kappa$. Given $L' > L$, we consider the contact forms $\alpha'_i(\kappa L')$ for $i = 1, 2$ on M' constructed in Lemma 7.2.3. Then there is an interpolating cobordism $(X, \lambda_{L'})$ from $(M', \alpha'_1(\kappa L'))$ at the positive end to $(M', \kappa^{-1}\alpha'_2(\kappa L'))$ at the negative end. Moreover, we can assume that $(X, \lambda_{L'})$ restricts to a piece of symplectization on a small neighborhood of $[0, 1] \times V$.

We define Φ_L by imposing the commutativity of the diagram

$$(7-2-4) \quad \begin{array}{ccc} \text{ECH}^L(M', \alpha'_1(\kappa L')) & \xrightarrow{\Phi^L} & \text{ECH}^{\kappa L}(M', \alpha'_2(\kappa L')) \\ \simeq \downarrow & & \downarrow \simeq \\ \text{ECH}^L(M, \alpha_1) & \xrightarrow{\Phi_L} & \text{ECH}^{\kappa L}(M, \alpha_2) \end{array}$$

where the vertical maps are the isomorphisms coming from Lemma 7.2.6 and the top map is induced by the interpolating cobordisms $(X, \lambda_{L'})$ via Lemma 3.1.7.

Remark 7.2.8 Using the blocking lemma, one can prove that the map Φ_L is supported, in the sense on Theorem 3.1.2(i), by holomorphic curves in $\mathbb{R} \times M$. See the proof of Lemma 7.2.6 for the details.

Lemma 7.2.9 Φ_L is independent of the choice of L' in diagram (7-2-4).

Proof Suppose $L \leq L_0 \leq L_1$, α_1 has no orbit sets of action L , and α_2 has no orbit sets of action κL . Then the diagram

$$(7-2-5) \quad \begin{array}{ccc} \text{ECH}^L(M', \alpha'_1(\kappa L_1)) & \xrightarrow{\Phi^L} & \text{ECH}^{\kappa L}(M', \alpha'_2(\kappa L_1)) \\ \Psi_1^{L, \kappa L_0, \kappa L_1} \downarrow & & \downarrow \Psi_2^{L, \kappa L_0, \kappa L_1} \\ \text{ECH}^L(M', \alpha'_1(\kappa L_0)) & \xrightarrow{\Phi^L} & \text{ECH}^{\kappa L}(M', \alpha'_2(\kappa L_0)) \end{array}$$

¹⁰This situation is slightly more general than that for which the blocking lemma has been stated and proved because we are in a cobordism. However the lemma is still valid and the proof is unchanged.

commutes by Theorem 3.1.2 since, by Lemma 3.1.6, the compositions of cobordisms $(X, \lambda'_{L_0}) \circ (W, \mu_1)$ and $(W, \mu_2) \circ (X, \lambda'_{L_1})$ are homotopic. The maps $\Psi_i^{L, \kappa L_0, \kappa L_1}$ induce the identity on $\text{ECH}(M, \alpha_i)$ by Lemma 7.2.7, so the maps on the top and bottom of (7-2-5) define the same map $\Phi_L: \text{ECH}^L(M, \alpha_1) \rightarrow \text{ECH}^{\kappa L}(M, \alpha_2)$. \square

Lemma 7.2.10 *Let α_1 and α_2 be contact forms as in Proposition 7.2.1. If L_i is an increasing sequence of positive real numbers such that α_1 has no orbit set of action L_i and α_2 has no orbit set of action κL_i for all i ,¹¹ then the maps*

$$\Phi_{L_i}: \text{ECH}^{L_i}(M, \alpha_1) \rightarrow \text{ECH}^{\kappa L_i}(M, \alpha_2)$$

define a morphism of directed systems.

Proof For all $L < L'$ as above, the diagram

$$(7-2-6) \quad \begin{array}{ccc} \text{ECH}^L(M, \alpha_1) & \xrightarrow{\Phi_L} & \text{ECH}^{\kappa L}(M, \alpha_2) \\ \downarrow & & \downarrow \\ \text{ECH}^{L'}(M, \alpha_1) & \xrightarrow{\Phi_{L'}} & \text{ECH}^{\kappa L'}(M, \alpha_2) \end{array}$$

where the vertical arrows are maps induced by the inclusions of chain complexes, commutes by Lemmas 7.2.7 and 7.2.9. \square

By taking the direct limit of the maps Φ_{L_i} from Lemma 7.2.10, we obtain a linear map

$$\Phi: \text{ECH}(M, \alpha_1) \rightarrow \text{ECH}(M, \alpha_2).$$

Since the roles of α_1 and α_2 are interchangeable, the same arguments can be used to define a map $\Phi': \text{ECH}(M, \alpha_2) \rightarrow \text{ECH}(M, \alpha_1)$ as a direct limit of maps Φ'_{L_j} .

Proof of Proposition 7.2.1 We prove that Φ and Φ' are inverses of each other. We identify the composition $\Phi'_{\kappa L} \circ \Phi_L$ (after a proper rescaling) with the map induced by an interpolating cobordism which is homotopic to a piece of symplectization. Then $\Phi'_{\kappa L} \circ \Phi_L = i_{L, \kappa^2 L}$, where $i_{L, \kappa^2 L}$ is the inclusion map. By taking the direct limit, we obtain $\Phi' \circ \Phi = \text{id}$. The proof of $\Phi \circ \Phi' = \text{id}$ is similar. \square

Remark 7.2.11 We sketch a possible strategy to prove the invariance of the group $\text{ECH}(M, \alpha)$ when the Reeb vector field of α defines a foliation on ∂M with closed leaves. This result will not be used in the rest of the article.

When ∂M is foliated by closed orbits of the Reeb vector field of α we would like to view $\text{ECH}(M, \alpha)$ as a direct limit of ECH groups of nondegenerate contact forms as in (4-5-1). We pick $L > 0$ and slightly extend (M, α) to $(M_\varepsilon, \alpha_\varepsilon)$ so that

- $M_\varepsilon = M \cup (T^2 \times [0, \varepsilon))$ where $\partial M = T^2 \times \{0\}$;
- $\alpha_\varepsilon|_M = \alpha$;

¹¹This condition can be fulfilled due to the fact that the action spectrum is discrete for a generic contact form.

- ∂M_ε is foliated by Reeb trajectories of α_ε with irrational slope; and
- there are no Reeb orbits of α_ε on $M_\varepsilon - M$ with action $\leq L$.

We now consider the chain complexes $ECC^L(M_\varepsilon, f_i \alpha_\varepsilon)$, where $f_i : M_\varepsilon \rightarrow \mathbb{R}$ is as in Lemma 4.5.1 for $i \gg 0$. Then

$$(7-2-7) \quad ECC^L(M, \alpha) \simeq ECC^L(M_\varepsilon, f_i \alpha_\varepsilon)$$

by Proposition 4.4.7. We then write the ECH group $ECH(M, \alpha)$ as a direct limit of groups $ECH^L(M_\varepsilon, f_i \alpha_\varepsilon)$ as in Corollary 3.2.3. We extend $(M_\varepsilon, f_i \alpha_\varepsilon)$ to a closed manifold by using Lemma 7.2.3 and apply the (analogs of the) results of this section to define the ECH cobordism maps.

7.3 Variants of ECH relative to the boundary

The goal of this subsection is to define the homology groups $ECH(M, \partial M, \alpha)$ and $\widehat{ECH}(M, \partial M, \alpha)$ which appear in the statement of Theorem 1.1.1. They are variants of $ECH(M, \alpha)$ and in many ways can be viewed as ECH groups relative to the boundary of M , whence the notation.

Let M be a manifold with $\partial M \simeq T^2$. Let α be a contact form on M which is nondegenerate on $\text{int}(M)$ and such that ∂M is a *negative* Morse–Bott torus. Then the ECH groups introduced in Section 7.1 are defined for (M, α) . In the rest of this section we make the further assumption that there exists a properly embedded oriented surface $(\Sigma, \partial \Sigma) \subset (M, \partial M)$ with connected boundary such that an orbit of the Morse–Bott torus has algebraic intersection number one with Σ .

As before, we pick two orbits on ∂M and label them h and e . There is a perturbation of α near ∂M which makes h hyperbolic and e elliptic; h corresponds to the maximum and e to the minimum of the perturbing Morse function.

Let \mathcal{P} be the set of simple Reeb orbits of α in the interior of M . Let $ECC_j^b(M, \alpha)$ be the chain complex generated by orbit sets γ constructed from $\mathcal{P} \cup \{e\}$, whose algebraic intersection number $\langle [\gamma], \Sigma \rangle$ is j . By construction, $ECC_j^b(M, \alpha)$ is a direct summand of $ECC^b(M, \alpha)$ and its differential is the restriction of the differential for $ECC^b(M, \alpha)$.

In the same way we write $ECC_j(M, \alpha)$ for the chain complex generated by orbit sets γ constructed from $\mathcal{P} \cup \{e, h\}$, whose algebraic intersection number $\langle [\gamma], \Sigma \rangle$ is j . By construction, $ECC_j(M, \alpha)$ is a direct summand of $ECC(M, \alpha)$ and its differential is the restriction of the differential for $ECC(M, \alpha)$.

Lemma 7.3.1 *There are inclusions of chain complexes*

$$ECC_j^b(M, \alpha) \rightarrow ECC_{j+1}^b(M, \alpha), \quad ECC_j(M, \alpha) \rightarrow ECC_{j+1}(M, \alpha)$$

given by the map $\gamma \mapsto e\gamma$, where we are using multiplicative notation for orbit sets.

Proof Let γ be an orbit set in M and u a holomorphic map with image in $\mathbb{R} \times M$ which is positively asymptotic to $e\gamma$. Then u has an irreducible component which is mapped to the trivial cylinder over e . In fact, by the trapping lemma, u cannot have nontrivial positive ends that limit to orbits on ∂M because M is a negative Morse–Bott torus. Also, one can check that, $Z' \in H_2(M, e\gamma, e\gamma')$ is obtained by adding a trivial cylinder over e to $Z \in H_2(M, \gamma, \gamma')$, then $I(e\gamma, e\gamma', Z') = 1$ whenever $I(\gamma, \gamma', Z) = 1$. This is a consequence of [Hutchings 2002, Proposition 7.1], since the associated partitions satisfy the admissibility conditions [Hutchings 2002, Definition 4.7, equations (23) and (24)]. It is crucial in the verification of the admissibility condition that, in the Morse–Bott situation, the outgoing partition for e with multiplicity n is (n) and the incoming partition is $(1, \dots, 1)$ for all n , together with the fact that every J -holomorphic map in $\mathbb{R} \times M$ with a positive end to e is a connector. Hence $\partial^b(e\gamma) = e\partial^b(\gamma)$ and $\partial(e\gamma) = e\partial(\gamma)$. \square

The homology of the chain complex $\text{ECC}_j^b(M, \alpha)$ will be written as $\text{ECH}_j^b(M, \alpha)$ and that of the chain complex $\text{ECC}_j(M, \alpha)$ will be written as $\text{ECH}_j(M, \alpha)$.

Definition 7.3.2 We define

$$\text{ECH}(M, \partial M, \alpha) = \lim_{j \rightarrow \infty} \text{ECH}_j^b(M, \alpha), \quad \widehat{\text{ECH}}(M, \partial M, \alpha) = \lim_{j \rightarrow \infty} \text{ECH}_j(M, \alpha).$$

Remark 7.3.3 The groups $\text{ECH}(M, \partial M, \alpha)$ and $\widehat{\text{ECH}}(M, \partial M, \alpha)$ can also be interpreted as the homology of the chain complexes obtained by taking the quotient of the chain complexes $\text{ECC}^b(M, \alpha)$ and $\text{ECC}(M, \alpha)$, respectively, by the subcomplexes generated by all elements of the form $e\gamma - \gamma$, where γ is any orbit set constructed from $\mathcal{P} \cup \{e\}$ in the case of $\text{ECH}(M, \partial M, \alpha)$ or from $\mathcal{P} \cup \{e, h\}$ in the case of $\widehat{\text{ECH}}(M, \partial M, \alpha)$. This alternative definition, unlike Definition 7.3.2, does not need the assumption that the Reeb orbits on the boundary have intersection one with a properly embedded surface.

Remark 7.3.4 The differentials in $\text{ECH}(M, \partial M, \alpha)$ and $\widehat{\text{ECH}}(M, \partial M, \alpha)$ preserve the total relative homology class of the generators. Then we can define subgroups $\text{ECH}(M, \partial M, \alpha, A)$ and $\widehat{\text{ECH}}(M, \partial M, \alpha, A)$ for every $A \in H_1(M, \partial M)$.

8 ECH of the solid torus

8.1 Overview of the computation

In this section we calculate various versions of ECH of the solid torus with certain boundary conditions and specific contact structures. We will write $V = D^2 \times S^1$ and use Convention 6.2.1 to compute the slope of essential curves in ∂V and in boundary-parallel tori contained in V .

The following lemma constructs the contact forms used in the main theorem. Let $V_0 \subset \dots \subset V_i \subset \dots \subset V$ be an exhaustion by concentric solid tori, $T_i = \partial V_i$ and $\mathcal{T} = \bigcup_i T_i$. Let (ρ, ϕ, θ) be the cylindrical coordinates on $V = D^2 \times S^1$ from Section 6.2. We assume that $T_i = \{\rho = \rho_i\}$. We will choose V_i so that the Reeb flow foliates $T_i = \partial V_i$ by orbits of *irrational* slope r_i .

Lemma 8.1.1 *There exists a contact form α_V on $V = D^2 \times S^1$ which is an arbitrarily C^∞ -small perturbation of the contact form α from Example 6.2.4 and which satisfies the following:*

- (a) *The Reeb orbits of α_V in $\text{int}(V)$ are nondegenerate.*
- (b) *α_V and α agree to infinite order along ∂V and along \mathcal{T} . In particular, the Reeb flow of α_V foliates the tori T_i by orbits of irrational slope r_i and ∂V by orbits of infinite slope.*
- (c) *For every i , all orbits in $V - V_i$ have slope greater than r_i .*

Proof Let $L_i \rightarrow \infty$ for $i = 1, 2, \dots$ be an increasing sequence of real numbers and let d be a metric on $C^\infty(V)$ inducing the C^∞ -topology.¹² Fix $\varepsilon > 0$ sufficiently small.

We claim that, for $i = 1, 2, \dots$, there exists a function¹³ $f_i : V \rightarrow \mathbb{R}$ such that

- (i) $e^{f_i} \alpha$ is L_i -nondegenerate,
- (ii) $d(f_i, f_{i-1}) < 2^{-i} \varepsilon$, and
- (iii) $\text{supp}(f_i - f_{i-1}) \subset \text{int}(V) - (\mathcal{O}_{i-1} \cup \mathcal{T})$,

where \mathcal{O}_i is the union of all simple Reeb orbits of $e^{f_i} \alpha$ with action less than L_i . Here we are setting $f_0 = 0$, $\mathcal{O}_0 = \emptyset$ and $L_0 = 0$. We define f_i inductively: We choose g_i such that $f_i = f_{i-1} + g_{i-1}$ satisfies (i)–(iii). In fact, as shown for example in the proof of [Colin and Honda 2013, Lemma 7.1], the functions g_i can be chosen arbitrarily close to 0 in the C^∞ -topology and with support in arbitrarily small neighborhoods of the Reeb orbits of action in $[L_{i-1}, L_i]$. The claim then follows. The sequence f_i is a Cauchy sequence, so we define $f = \lim_{i \rightarrow \infty} f_i$ and $\alpha_V = e^f \alpha$. The contact form α_V satisfies (a) and (b).

It remains to prove (c). But this is immediate since the slope in Example 6.2.4 is strictly increasing with the radius on the region $V - V_i$ and we are performing a C^∞ -small perturbation so that this property is preserved. □

Now, ∂V is a positive α_V -Morse–Bott torus. We can perturb α_V so that the Morse–Bott family for ∂V becomes a pair of nondegenerate Reeb orbits e' and h' , where e' is an elliptic orbit corresponding to the maximum of the perturbing function and h' is a hyperbolic orbit corresponding to the minimum. The following is the main result of this section:

Theorem 8.1.2 *Let α_V be a contact form on V as constructed in Lemma 8.1.1. Then:*

- (1) $\text{ECH}(\text{int}(V), \alpha_V) \simeq \mathbb{F}$, generated by \emptyset .
- (2) $\text{ECH}^\sharp(V, \alpha_V) \simeq 0$.
- (3) $\text{ECH}(V, \alpha_V) \simeq 0$.
- (4) $\text{ECH}^b(V, \alpha_V) \simeq \mathbb{F}[e']$, where $\mathbb{F}[e']$ is the polynomial ring generated by e' over \mathbb{F} .

¹²For example, we can take $d(f, g) = \sum_{k=0}^\infty 2^{-k} \|f - g\|_{C^k} / (1 + \|f - g\|_{C^k})$.

¹³The functions f_i , g_i and f introduced in this proof are, of course, unrelated to the functions f and g defining α in Example 6.2.4.

Remark 8.1.3 Proposition 7.2.1 does not cover contact forms whose Reeb flow has rational slope on ∂V , so we cannot claim that the computation in Theorem 8.1.2 is independent of the contact form. However, the computation for the contact forms α_V constructed in Lemma 8.1.1 will be sufficient for the proof of Theorem 1.1.1.

The proof of (1) proceeds as follows: In Section 8.2 we compute $\text{ECH}(V_i, \alpha_V|_{V_i})$. Since the slope of the Reeb flow of α_V on $T_i = \partial V_i$ is irrational, we can use Proposition 7.2.1 to replace the contact forms $\alpha_V|_{V_i}$ with different forms for which the computation is easy. We also lift the relative grading on the ECH groups given by the ECH index to an absolute grading which is compatible with the maps induced by the interpolating cobordisms. In Section 8.3 we prove that the inclusions $V_i \subset V_{i+1}$ induce inclusions of chain complexes $\text{ECC}(V_i, \alpha_V|_{V_i}) \subset \text{ECC}(V_{i+1}, \alpha_V|_{V_{i+1}})$ as a consequence of the blocking lemma. This implies that

$$\text{ECH}(\text{int}(V), \alpha_V) = \lim_{i \rightarrow \infty} \text{ECH}(V_i, \alpha_V|_{V_i}).$$

We then use the absolute grading to conclude the proof: the degrees of the generators of $\text{ECH}(V_i, \alpha_V|_{V_i})$ that are different from \emptyset go to infinity as $i \rightarrow \infty$, so only \emptyset survives in the direct limit.

The proofs of (2)–(4) are given in Section 8.5 and use (1) and some results on holomorphic curves in $\mathbb{R} \times V$ due to Taubes and Wendl.

8.2 $\text{ECH}(V, \alpha)$ when the Reeb flow has irrational slope on the boundary

In this subsection we compute $\text{ECH}(V, \alpha)$ for contact forms α whose Reeb flow foliates ∂V by orbits of irrational slope and whose underlying contact structure gives the standard contact neighborhood of a transverse knot. For this boundary condition we have proved the invariance of ECH, so, by Proposition 7.2.1, we can choose a particularly simple contact form to do the computation.

Let $r > 0$ be an irrational number. Pick a contact form α_r on $V \simeq D^2 \times S^1$ as in Example 6.2.3 such that the following hold:

- The boundary ∂V and all the concentric tori T_ρ for $\rho \in (0, 1]$ are foliated by Reeb orbits of irrational slope r .
- The contact structure $\ker \alpha_r$ is transverse to all the fibers $\{\text{pt}\} \times S^1$.

There is only one simple closed orbit, namely the core $c = \{0\} \times S^1$. The orbit c is elliptic and all its multiple covers c^n are nondegenerate due to the irrationality of r . Note that $[c^n] = n[S^1] \in H_1(V)$, so we immediately have the following lemma:

Lemma 8.2.1 $\text{ECH}(\text{int}(V), \alpha_r; n[S^1]) \simeq \mathbb{F}$, generated by c^n , if $n \geq 0$ (where $c^n = \emptyset$ if $n = 0$) and $\text{ECH}(\text{int}(V), \alpha_r; n[S^1]) = 0$ if $n < 0$.

In order to plug this computation into the direct limit in the proof of Theorem 8.1.2, we define an absolute grading on the ECH groups of the solid torus in a way which is compatible with the cobordism maps.

For simplicity we will consider only contact forms α which satisfy the following assumption:

- (\star) The core of V is an elliptic Reeb orbit c , all of whose multiple covers are nondegenerate.

The contact forms α_r in Lemma 8.2.1, as well as the contact forms $\alpha_V|_{V_i}$ of Lemma 8.1.1, satisfy this assumption.

Let $\xi = \ker \alpha$. We chose a trivialization τ of ξ such that its restriction to the core orbit e is homotopic to the pullback of a basis of T_0D^2 and the linearized Reeb flow at e is a rotation by angle $2\pi\theta$ with $\theta \in \mathbb{R} - \mathbb{Q}$.

Lemma 8.2.2 *Let α be a contact form on a solid torus V which satisfies (\star). Then there is an absolute grading I on $\text{ECC}(\text{int}(V), \alpha)$ such that:*

- (1) $I(c^n) = \sum_{k=1}^n (2\lfloor k\theta \rfloor + 1)$.
- (2) If γ_1 and γ_2 are two orbit sets and Z is a surface from γ_1 to γ_2 , then

$$I(\gamma_1, \gamma_2, Z) = I(\gamma_1) - I(\gamma_2).$$

Proof Given an orbit set γ with $[\gamma] = n[S^2]$, we choose a τ -trivial surface Z from γ to e^n and define

$$(8-2-1) \quad I(\gamma) := \tilde{\mu}_\tau(\gamma) + c_1(\xi|_Z, \tau) + Q_\tau(Z).$$

Since $H_2(V) = 0$, $I(\gamma, c^n, Z)$ is independent of Z by [Hutchings 2002, Lemma 2.5(a)]. Hence $I(\gamma)$ is well defined.

- (1) follows from the calculation $\tilde{\mu}_\tau(c^n) = \sum_{k=1}^n (2\lfloor k\theta \rfloor + 1)$ using [Hutchings 2009, formula 2.3] and
- (2) follows from the additivity of the ECH index. □

Lemma 8.2.3 *Let α_1 and α_2 be contact forms on V which coincide on ∂V to first order and define contact structures which are isotopic relatively to the boundary. If both α_1 and α_2 satisfy (\star) and their Reeb flows foliate ∂V by orbits of irrational slope, then the isomorphism $\text{ECH}(V, \alpha_1) \simeq \text{ECH}(V, \alpha_2)$ from Proposition 7.2.1 preserves the absolute grading I .*

Proof We denote by I_1 and I_2 the absolute grading on the groups $\text{ECH}(V, \alpha_1)$ and $\text{ECH}(V, \alpha_2)$, respectively. We know from Remark 7.2.8 that the isomorphism $\text{ECH}(V, \alpha_1) \xrightarrow{\cong} \text{ECH}(V, \alpha_2)$ is supported by holomorphic buildings in a completed interpolating cobordism $([0, 1] \times V, \lambda)$ from (V, α_1) to (V, α_2) .¹⁴ Moreover, by [Cristofaro-Gardiner 2013, Theorem 5.1], those buildings have total ECH index $I = 0$ for a version of the ECH index in cobordisms; see [Hutchings 2009] for its definition. Then the lemma holds if

$$(8-2-2) \quad I(\gamma_1, \gamma_2, Z) = I_1(\gamma_1) - I_2(\gamma_2)$$

for all surfaces Z in $[0, 1] \times V$ connecting an orbit set γ_1 for α_1 to an orbit set γ_2 for α_2 .

¹⁴To add some confusion, what is called V here corresponds to M in Section 7.2.

Since $H_2(V) = 0$, we can assume that Z is the union of a surface Z_1 from γ_1 to c^n (for some n), the surfaces Z_0^n consisting of n copies of the cylinder Z_0 over the core orbit c , and a surface Z_2 from c^n to γ_2 . Moreover, we can assume that Z_1 and Z_2 project to surfaces in V , so that $I(\gamma_1, c^n, Z_1) = I_1(\gamma_1) - I_1(c^n)$ and $I_2(c^n, \gamma_2, Z_2) = I_2(c^n) - I_2(\gamma_2)$. Then

$$I(\gamma_1, \gamma_2, Z) = I_1(\gamma_1) - I_1(c^n) + I(c^n, c^n, Z_0^n) + I_2(c^n) - I_2(\gamma_2)$$

and consequently (8-2-2) holds if and only if

$$I(c^n, c^n, Z_0^n) = I_1(c^n) - I_2(c_n)$$

for every $n \geq 0$. This is however the case because

$$c_1(T([0, 1] \times V)|_{Z_0^n}, \tau) = Q_\tau(Z_0^n) = 0. \quad \square$$

By combining Proposition 7.2.1 and Lemmas 8.2.1–8.2.3 we obtain:

Lemma 8.2.4 *If α is a contact form on V satisfying (\star) and ∂V is foliated by Reeb orbits of irrational slope $r > 0$, then*

$$\text{ECH}(V, \alpha, n[S^1]) \simeq \begin{cases} \mathbb{F} & \text{in degree } I = \sum_{k=1}^n (2\lfloor kr \rfloor + 1) \text{ for } n > 0, \\ \mathbb{F} & \text{in degree } I = 0 \text{ for } n = 0, \\ 0 & \text{for } n < 0. \end{cases}$$

8.3 Computation of $\text{ECH}(\text{int}(V), \alpha_V)$

The goal of this subsection is to compute $\text{ECH}(\text{int}(V), \alpha_V)$, where α_V is a contact form as constructed in Lemma 8.1.1.

Lemma 8.3.1 *The inclusions $V_i \subset V_j$ for $i < j$ induce inclusions of chain complexes*

$$(8-3-1) \quad \text{ECC}(V_i, \alpha_V|_{V_i}) \rightarrow \text{ECC}(V_j, \alpha_V|_{V_j}).$$

Moreover, the inclusions $V_i \subset V$ induce inclusions of chain complexes

$$\text{ECC}(V_i, \alpha_V|_{V_i}) \rightarrow \text{ECC}(\text{int}(V), \alpha_V).$$

Proof Let γ be an orbit set whose orbits are contained in V_i . We will prove that every J -holomorphic map $u: F \rightarrow \mathbb{R} \times V$ which has γ at its positive end has image in $\mathbb{R} \times V_i$. Let γ' be the orbit set at the negative end of u . We first prove that all the orbits of γ' must be contained in V_i . Arguing by contradiction, suppose $\gamma' = \gamma'_{\text{in}} \gamma'_{\text{out}}$, where the orbits of γ'_{in} are in V_i and the orbits of $\gamma'_{\text{out}} \neq \emptyset$ are in $V - V_i$. The Reeb vector field determines a homology class $s_i \in H_1(T_i; \mathbb{R})$, up to multiplication by a positive constant, which has slope r_i using Convention 6.2.1. We can also regard $[\gamma'_{\text{out}}]$ as a homology class in $H_1(T_i; \mathbb{R})$ and the slope of $[\gamma'_{\text{out}}]$ is larger than r_i because every Reeb orbit in $V - V_i$ has slope larger than r_i by Lemma 8.1.1. This implies that $[\gamma'_{\text{out}}] \cdot s_i > 0$.

Denote by u_V the composition of u with the projection $\mathbb{R} \times V \rightarrow V$ and let $\delta \in H_1(T_i; \mathbb{R})$ be the homology class of the intersection $u_V(F) \cap T_i$, oriented as the boundary of u_V restricted to V_i . (Recall that the

tori T_i are foliated by Reeb orbits of irrational slope, so that u has no ends at T_i .) Then $\delta = -[\gamma'_{\text{out}}]$, so $\delta \cdot s_i < 0$. This contradicts the positivity of intersections in dimension three (Lemma 5.2.2) and therefore all orbits in γ' are contained in V . Hence, Lemma 5.2.3(1) (blocking lemma) implies that $u(F) \subset \mathbb{R} \times V_i$. \square

With all these preliminary steps in place, the computation of $\text{ECH}(\text{int}(V), \alpha_V)$ is straightforward.

Proposition 8.3.2 $\text{ECH}(\text{int}(V), \alpha_V) \simeq \mathbb{F}$ and is generated by \emptyset .

Proof By Lemma 8.3.1,

$$(8-3-2) \quad \text{ECH}(\text{int}(V), \alpha_V) = \lim_{i \rightarrow \infty} \text{ECH}(V_i, \alpha_V|_{V_i}).$$

Moreover, all the generators of $\text{ECH}(V_i, \alpha_V|_{V_i})$ in Lemma 8.2.4 that are different from \emptyset have degree $I > [2r_i] + 1$. Since $r_i \rightarrow \infty$ and the inclusions

$$\text{ECH}(V_i, \alpha_V|_{V_i}) \rightarrow \text{ECH}(V_j, \alpha_V|_{V_j})$$

are degree-preserving, every generator different from \emptyset eventually is mapped to zero in the directed system. Hence $\text{ECH}(\text{int}(V), \alpha_V) \simeq \mathbb{F}$ and is generated by \emptyset . \square

8.4 Finite-energy foliations

In this subsection we study finite-energy foliations of $\mathbb{R} \times V$ and $\mathbb{R} \times T^2 \times [1, 2]$ which have been constructed by [Wendl 2008; 2005; Taubes 2002]. Finite-energy foliations were introduced in [Hofer et al. 2003]; here we recall their definition.

Definition 8.4.1 A *finite-energy foliation* of a symplectic cobordism (W, ω) with an adapted almost complex structure J is a codimension two foliation of W such that every leaf is the image of an embedded J -holomorphic map with finite energy.

Here we are using the notion of energy from [Bourgeois et al. 2003, Section 6.1]. The ends of a finite-energy J -holomorphic map in W are asymptotic to cylinders over Reeb orbits.

The purpose of considering finite-energy foliations is twofold: they constrain holomorphic curves by the positivity of intersections and contribute to the ECH differential via the Morse–Bott construction. The foliation on $\mathbb{R} \times V$ will be used in the proof of Theorem 8.1.2(2)–(4) and the foliation on $\mathbb{R} \times T^2 \times [1, 2]$ will be used in the proofs of Lemmas 9.5.3 and 9.9.3.

8.4.1 Automatic transversality For certain moduli spaces of J -holomorphic maps in dimension four, transversality holds for topological reasons and there is no need to perturb the almost complex structure. In this subsection we describe such *automatic transversality* results of Wendl [2010]. We need to discuss automatic transversality, since the finite-energy foliations that we consider are constructed for very symmetric, and therefore nongeneric, almost complex structures.

Let $F = \bar{F} - z$, where \bar{F} is a closed oriented surface and $z = \{z_1, \dots, z_r\}$ is a finite set of punctures. Following Wendl [2010], we fix a partition $\mathcal{P} = \{z_C^+, z_C^-, z_U^+, z_U^-\}$ of z . We use the superscript $+$ (resp. $-$) to indicate the punctures which correspond to the positive (resp. negative) ends and define $z_C = z_C^+ \cup z_C^-$ and $z_U = z_U^+ \cup z_U^-$.

To any puncture $z \in z_C$ we associate an orbit γ_z (which can either be nondegenerate or belong to a Morse–Bott family) and to any puncture $z \in z_U$ we associate a Morse–Bott family \mathcal{N}_z . We write

$$\mathcal{M}^{\mathcal{P}} = \mathcal{M}(\{\gamma_z\}_{z \in z_C^+}, \{\mathcal{N}_z\}_{z \in z_U^+}, \{\gamma_z\}_{z \in z_C^-}, \{\mathcal{N}_z\}_{z \in z_U^-})$$

for the moduli space of holomorphic maps $u: (F, j) \rightarrow (\mathbb{R} \times M, J)$, which are positively asymptotic to the orbits γ_z for $z \in z_C^+$ and to the Morse–Bott families \mathcal{N}_z for $z \in z_U^+$ and are negatively asymptotic to the orbits γ_z for $z \in z_C^-$ and to the Morse–Bott families \mathcal{N}_z for $z \in z_U^-$. Here we range over all complex structures j on F and divide by automorphisms of the domain.

Ends which correspond to punctures in z_C are called *constrained ends* and ends which correspond to punctures in z_U are called *unconstrained ends*. The definition of $\mathcal{M}^{\mathcal{P}}$ motivates this terminology: constrained ends are asymptotic to a specific orbit, while unconstrained ends are asymptotic to ends which can move in a Morse–Bott family.

The virtual dimension of $\mathcal{M}^{\mathcal{P}}$ at u will be denoted by $\text{ind}(u, \mathcal{P})$. Fix $\delta > 0$ arbitrarily small. For every puncture $z \in z$, we define

$$c_z = \begin{cases} \delta & \text{if } z \in z_C, \\ -\delta & \text{if } z \in z_U. \end{cases}$$

Choose a symplectic trivialization τ of $\xi|_{\gamma_z}$ which is complex linear with respect to J . Let A_{γ_z} be the asymptotic operator of γ_z . With respect to the trivialization τ , A_{γ_z} can be written in the form $-J d/dt + S(t)$, where $J = \begin{pmatrix} 0 & -1 \\ 1 & 0 \end{pmatrix}$, t is the direction of γ_z , and $S(t)$ is a loop of symmetric matrices. Also let $A_{\gamma_z}^{\mathcal{P}} = A_{\gamma_z} \pm c_z \text{Id}$ be the *perturbed* asymptotic operator of γ_z , where we choose the positive (resp. negative) sign if $z \in z^+$ (resp. $z \in z^-$). This is equivalent to turning on negative (resp. positive) exponential weights at positive unconstrained (resp. constrained) ends and negative constrained (resp. unconstrained) ends.

The perturbed asymptotic operator $A_{\gamma_z}^{\mathcal{P}}$ yields a path of symplectic matrices $\Phi_z^{\mathcal{P}}$, and we define $\mu_{\tau}(\gamma_z, \mathcal{P}) = \mu(\Phi_z^{\mathcal{P}})$. We say that a puncture z is *even* if $\mu_{\tau}(\gamma_z, \mathcal{P})$ is even and we denote by $\#\Gamma_0(u, \mathcal{P})$ the number of even punctures of (u, \mathcal{P}) . By the properties of the Conley–Zehnder index the set of even punctures, and therefore $\#\Gamma_0(u, \mathcal{P})$, does not depend on the trivialization τ .

Theorem 8.4.2 [Wendl 2010, equation (1.1) and Remark 1.2] *Let $u: F \rightarrow \mathbb{R} \times M$ be a J -holomorphic map and \mathcal{P} a partition of the ends of u . Then*

$$(8-4-1) \quad \text{ind}(u, \mathcal{P}) = -\chi(F) + 2c_1(u^*\xi, \tau) + \sum_{z \in z^+} \mu_{\tau}(\gamma_z, \mathcal{P}) - \sum_{z \in z^-} \mu_{\tau}(\gamma_z, \mathcal{P}).$$

Moreover, if u is an immersion, then it is a regular point of $\mathcal{M}^{\mathcal{P}}$ if

$$(8-4-2) \quad \text{ind}(u, \mathcal{P}) > 2g(F) - 2 + \#\Gamma_0(u, \mathcal{P}).$$

The following lemma computes $\mu_\tau(\gamma_z, \mathcal{P})$ in terms of the Conley–Zehnder index of a nondegenerate perturbation of the Reeb orbit:

Lemma 8.4.3 *Suppose $\delta > 0$ is sufficiently small.*

- (1) *If γ_z is a nondegenerate orbit, then $\mu_\tau(\gamma_z, \mathcal{P}) = \mu_\tau(\gamma_z)$.*
- (2) *If γ_z belongs to a Morse–Bott family \mathcal{N} and γ_{\min} and γ_{\max} are the nondegenerate Reeb orbits corresponding to a minimum and a maximum of a Morse function on \mathcal{N} , then*
 - $\mu_\tau(\gamma_z, \mathcal{P}) = \mu_\tau(\gamma_{\min})$ *if $z \in \mathbf{z}_C^+ \cup \mathbf{z}_U^-$, and*
 - $\mu_\tau(\gamma_z, \mathcal{P}) = \mu_\tau(\gamma_{\max})$ *if $z \in \mathbf{z}_U^+ \cup \mathbf{z}_C^-$.*
- (3) $\#\Gamma_0(u, \mathcal{P})$ *is the total number of*
 - *ends at even nondegenerate orbits,*
 - *constrained positive ends and unconstrained negative ends at positive Morse–Bott tori, and*
 - *unconstrained positive ends and constrained negative ends at negative Morse–Bott tori.*

Proof (1) This is immediate.

(2) Let $T = T_{\mathcal{N}} \subset M$ be the torus corresponding to \mathcal{N} and let $g : M \rightarrow \mathbb{R}$ and $\bar{g}_{\mathcal{N}} : \mathcal{N} \rightarrow \mathbb{R}$ be C^∞ -small functions satisfying (P1)–(P4) from Section 4.1. We denote the Morse–Bott form by α_0 and its Reeb vector field by R_0 . Then the Reeb vector field of the perturbed contact form $(1 + g)\alpha_0$ is $R = (1 + g)^{-1}R_0 + X$, where $X \in \xi = \ker \alpha_0$ is a solution of

$$i_X d\alpha_0 = (1 + g)^{-2}(dg - dg(R_0)\alpha_0).$$

If we choose an almost complex structure J on ξ and a metric h on M which is compatible with J and α_0 in the sense that R_0 is a unit vector field which is orthogonal to ξ and $h|_{\xi \otimes \xi} = d\alpha_0(\cdot, J\cdot)$, then

$$X = -(1 + g)^{-2}J(\nabla g - h(\nabla g, R_0)R_0).$$

Let γ be an orbit in \mathcal{N} which corresponds to a critical point of \bar{g} , so that γ is also a Reeb orbit for R . We can associate two asymptotic operators to γ : the operator A_γ when we regard γ as a Reeb orbit of R_0 , and the operator A'_γ when we regard γ as a Reeb orbit of R .

Let τ be the period of γ as an orbit of R and assume for simplicity that the period of γ as an orbit of R_0 is 1. Then τ is equal to the value of $1 + g$ at any point of γ . If ∇ is a symmetric connection, the asymptotic operators can be written as

$$A_\gamma = -J(\nabla_t - \nabla R_0), \quad A'_\gamma = -J(\nabla_t - \tau \nabla R);$$

see [Wendl 2010, page 370]. Since $dg = 0$ and $\nabla g = 0$ along γ , we have

$$\begin{aligned} \nabla R &= (1 + g)^{-1}\nabla R_0 - (1 + g)^{-2}\nabla(J(\nabla g - h(\nabla g, R_0)R_0)), \\ \nabla(J(\nabla g - h(\nabla g, R_0)R_0)) &= (\nabla J)(\nabla g - h(\nabla g, R_0)R_0) + J\nabla(\nabla g - h(\nabla g, R_0)R_0) \\ &= J\nabla(\nabla g - h(\nabla g, R_0)R_0) = JHg \end{aligned}$$

along γ , where Hg is the Hessian of g restricted to the ξ -directions. Hence

$$A'_\gamma = -J(\nabla_t - \nabla R_0 + (1 + g)^{-1} JHg) = A_\gamma + (1 + g)^{-1} Hg.$$

If \bar{g} has a minimum at γ , then $Hg \geq 0$ along γ and A'_γ has the same Conley–Zehnder index as $A_\gamma + \delta$. On the other hand, if \bar{g} has a maximum at γ , then A'_γ has the same Conley–Zehnder index as $A_\gamma - \delta$.

(3) is immediate from (2). \square

8.4.2 Foliations on $\mathbb{R} \times V$ and $\mathbb{R} \times T^2 \times [1, 2]$ We first describe the finite-energy foliation on $\mathbb{R} \times V$. The following is proven in [Wendl 2008]; see pages 594–600, especially the removal of singularities argument on page 599; the gist of the proof is to reduce the J -holomorphic curve equation to an ODE [loc. cit., equations (37a) and (37b)].

Proposition 8.4.4 *Let α be a contact form on V as in Example 6.2.4 and J_0 a “cylindrically symmetric” almost complex structure on $\mathbb{R} \times V$ (ie J_0 depends only on the radial coordinate ρ of V) which is adapted to α . Then there is a finite-energy foliation \mathcal{Z}_0 of $\mathbb{R} \times V$ such that:*

- (1) $\mathbb{R} \times \text{int}(V)$ is foliated by J_0 -holomorphic planes which are positively asymptotic to the Reeb orbits on ∂V .
- (2) $\mathbb{R} \times \partial V$ is foliated by trivial cylinders over Reeb orbits of ∂V .

Any orbit of ∂V is the limit of a unique 1-dimensional \mathbb{R} -invariant family of noncylindrical leaves and the projections of the leaves to $\text{int}(V)$ foliate $\text{int}(V)$ by meridian disks.

We will use a finite-energy foliation of $\mathbb{R} \times V$ in the proof of Theorem 8.1.2(2)–(4). However, the contact form used there is a small perturbation α_V of α , and for this reason we need to show that \mathcal{Z}_0 persists if α and J_0 are deformed.

Proposition 8.4.5 *If α_V is the C^∞ -small perturbation of α from Lemma 8.1.1, then there is a finite-energy foliation \mathcal{Z}_1 of $(\mathbb{R} \times V, d(e^s \alpha_V))$ which is isotopic to \mathcal{Z}_0 by the lift to $\mathbb{R} \times V$ of an isotopy of V relative to the boundary.*

Proof A leaf u of \mathcal{Z}_0 , considered as a J_0 -holomorphic map with a *constrained* end, has Fredholm index one and is automatically transverse by Theorem 8.4.2. Indeed, by Lemma 8.4.3, the index of u , as a J_0 -holomorphic map with constrained end, is equal to the index of a J_ε -holomorphic plane u_ε which limits to a hyperbolic orbit h (ie the minimum of the Morse–Bott family) on the boundary for a perturbed contact form. If τ is the trivialization of ξ along h given by $\xi \cap T\partial V$, then $\chi(D^2) = 1$, $c_1(u_\varepsilon^* \xi, \tau) = 1$, $\mu_\tau(h) = 0$, and therefore $\text{ind}(u) = \text{ind}(u_\varepsilon) = 1$. The same leaf u , considered as a J_0 -holomorphic map with an *unconstrained* end, has Fredholm index two and is also automatically transverse.

Let \mathcal{M}_0 be the 2-dimensional moduli space of J_0 -holomorphic planes which are leaves of \mathcal{Z}_0 . By the unconstrained automatic transversality, if we perturb α and the almost complex structure J_0 slightly, then each leaf of \mathcal{Z}_0 is deformed to a J -holomorphic curve for the new almost complex structure J and the

space \mathcal{M}_1 of deformed J -holomorphic curves is diffeomorphic to \mathcal{M}_0 . On the other hand, the constrained automatically transversality implies that for each Reeb orbit in ∂V there is exactly one \mathbb{R} -invariant family of J -holomorphic maps in \mathcal{M}_1 positively asymptotic to that orbit.

The maps in \mathcal{M}_1 are embeddings because embeddedness is an open condition and the exponential decay estimates imply that no self-intersection can be created near infinity. Moreover, the relative intersection number of their images is zero and by the positivity of intersections, their images are pairwise disjoint, so they define a finite-energy foliation \mathcal{Z}_1 of $\mathbb{R} \times V$. □

Now we discuss a finite-energy foliation \mathcal{Z}_2 on a completed interpolating cobordism $(\mathbb{R} \times T^2 \times [1, 2], \lambda)$ between two contact forms satisfying (6-1-1). In the case of a symplectization, this foliation was constructed by Wendl [2008].

We assume that every slice $\{s\} \times T^2 \times [1, 2]$ is a contact type hypersurface; Then we can write $\lambda = e^s \alpha_s$, where α_s is a contact form on $\{s\} \times T^2 \times [1, 2]$ given by (6-1-1) for pairs of functions (f_s, g_s) which depend on s and y . The forms α_s will define a 2-plane field ξ and a vector field R on $\mathbb{R} \times T^2 \times [1, 2]$ which restrict to the contact structure and the Reeb vector field on each slice $\{s\} \times T^2 \times [1, 2]$. In particular, R is tangent to the tori $\{s\} \times T^2 \times \{y\}$. Moreover, we assume that α_s is constant in s near $\mathbb{R} \times T^2 \times \{1, 2\}$ and that R is parallel to ∂_t when $y = 1, 2$ and not parallel to it otherwise. Finally, we assume that the tori $\{s\} \times T^2 \times \{1\}$ and $\{s\} \times T^2 \times \{2\}$ are foliated by Morse–Bott families \mathcal{N}_1 and \mathcal{N}_2 , respectively, for each s , where \mathcal{N}_1 is negative and \mathcal{N}_2 is positive.

We take an almost complex structure J on $\mathbb{R} \times T^2 \times [1, 2]$ with coordinates (s, ϑ, t, y) such that the following hold:

- J is adapted to λ .
- J is invariant in the s -direction on the cylindrical ends of the cobordism.
- J is invariant in the ϑ, t -directions.
- $J(\partial_s) = R$.
- J sends $\partial_y \in \xi$ to the tangent space to $\{s\} \times T^2 \times \{y\}$.

For the existence of such an almost complex structure we need to verify that the plane distribution generated by ∂_s and R is $d\lambda$ -symplectic, and that ∂_y belongs to its $d\lambda$ -orthogonal. The first property is guaranteed if α_s varies sufficiently slowly in s , while the second property follows from the fact that $\alpha_s(\partial_y) = 0$ everywhere. Finally, the symmetries of J reflect the symmetries of the forms α_s .

Lemma 8.4.6 *Let $(\mathbb{R} \times T^2 \times [1, 2], \lambda)$ be an exact symplectic cobordism with an adapted almost complex structure J as above. Then there is a 2-dimensional family \mathcal{Z}_2 of holomorphic cylinders $Z_{s,\vartheta}$ on $\mathbb{R} \times T^2 \times [1, 2]$ for $(s, \vartheta) \in \mathbb{R} \times \mathbb{R}/\mathbb{Z}$ which foliate $\mathbb{R} \times \text{int}(T^2 \times [1, 2])$ and project to cylinders $\vartheta = \text{const}$ in $\text{int}(T^2 \times [1, 2])$. Each cylinder $Z_{s,\vartheta}$ is positively asymptotic to a Reeb orbit in \mathcal{N}_2 and negatively asymptotic to a Reeb orbit in \mathcal{N}_1 .*

Proof Let us write $v = J(\partial_y)$. Our conditions on J and R imply that $\partial_t = a(s, y)v + b(s, y)R$ with $b(s, y) \neq 0$ everywhere and $a(s, y) = 0$ only when $y = 1$ or $y = 2$, in which case $\partial a/\partial y|_{y=0,1} \neq 0$. Then $J(\partial_t) = -a(s, y)\partial_y - b(s, y)\partial_s$. The vector fields ∂_t and $Y(s, y) = a(s, y)\partial_y + b(s, y)\partial_s$ span a J -invariant 2-plane distribution on $\mathbb{R} \times T^2 \times [1, 2]$. Since a and b do not depend on t and ϑ , this distribution is integrable and every integral submanifold in $\mathbb{R} \times T^2 \times [1, 2]$ is the product of \mathbb{R}/\mathbb{Z} with coordinate t and an integral curve of Y on the strip $\mathbb{R} \times [1, 2]$.

The functions a and b are bounded in $\mathbb{R} \times [0, 1]$ because $\partial a/\partial s|_{|s| \gg 0} = \partial b/\partial s|_{|s| \gg 0} = 0$. This implies that Y is complete. Moreover, the maximal integral curves of Y on $\mathbb{R} \times (1, 2)$ project diffeomorphically onto $(1, 2)$ and have vertical asymptotes for $y \rightarrow 1$ and $y \rightarrow 2$ because $a(s, y) \neq 0$ when $y \neq 1, 2$. \square

Lemma 8.4.7 *Let $u_{s,\vartheta}: \mathbb{R} \times S^1 \rightarrow \mathbb{R} \times T^2 \times [1, 2]$ be a J -holomorphic map which parametrizes the holomorphic cylinder $Z_{s,\vartheta}$. Then $(u_{s,\vartheta}, \mathcal{P})$ satisfies automatic transversality if at least one end is unconstrained.*

Proof By Theorem 8.4.2,

$$\text{ind}(u_{s,\vartheta}, \mathcal{P}) = \mu_\tau(\gamma_2, \mathcal{P}) - \mu_\tau(\gamma_1, \mathcal{P}),$$

where $\gamma_i \in \mathcal{N}_i$, so $\text{ind}(u_{s,\vartheta}, \mathcal{P}) = 2 - \#\Gamma_0(u_{s,\vartheta}, \mathcal{P})$ by Lemma 8.4.3. Hence the condition for automatic transversality in Theorem 8.4.2 holds if $\#\Gamma_0(u_{s,\vartheta}, \mathcal{P}) < 2$. Both the constrained negative end at \mathcal{N}_1 and the constrained positive end at \mathcal{N}_2 are even and the lemma follows. \square

8.4.3 Constraints on holomorphic curves Finite-energy foliations constrain J -holomorphic maps with the same asymptotics. The following lemma describes an instance of this phenomenon. A similar situation has also been considered in [Wendl 2013].

Lemma 8.4.8 *Let P be a compact oriented surface and α a Morse–Bott contact form on $S^1 \times P$ such that $S^1 \times \partial P$ is a union of Morse–Bott tori and $\{\vartheta\} \times \partial P$ is a union of Reeb orbits for each $\vartheta \in S^1$. If $\mathbb{R} \times S^1 \times P$ has a finite-energy foliation \mathcal{Z} on which $\mathbb{R} \times S^1$ acts freely and transitively and is such that every leaf projects diffeomorphically to $\text{int}(P)$, then every somewhere-injective finite-energy J -holomorphic map $u: F \rightarrow \mathbb{R} \times S^1 \times P$ with no ends at a Reeb orbit in $S^1 \times \text{int}(P)$ is a leaf of \mathcal{Z} .*

Proof Let $Z_{s,\vartheta}$ be the leaves of \mathcal{Z} parametrized by $(s, \vartheta) \in \mathbb{R} \times S^1$. Suppose first that there is a leaf Z_{s_0,ϑ_0} such that $u(F) \cap Z_{s_0,\vartheta_0} \neq \emptyset$ and which is asymptotic to different Reeb orbits than u . The intersection points in $u(F) \cap Z_{s_0,\vartheta_0}$ are isolated and positive. However, $u(F) \cap Z_{s'_0,\vartheta_0} = \emptyset$ if s'_0 is sufficiently large, a contradiction. Hence there exists some $\vartheta_0 \in S^1$ such that $u(F) \subset \bigcup_{s \in \mathbb{R}} Z_{s,\vartheta_0}$ and the leaves Z_{s,ϑ_0} are asymptotic to the same Reeb orbits as u . If $u(F)$ is not contained in a leaf, this forces the intersection $u(F) \cap Z_{s_0,\vartheta_0}$ to be one-dimensional for some $s_0 \in \mathbb{R}$. This is too large an intersection, and the unique continuation for J -holomorphic maps [McDuff and Salamon 2004, Theorem 2.3.2] implies that $u(F)$ is a leaf of \mathcal{Z} . \square

Remark 8.4.9 The proof of Lemma 8.4.8 goes through unchanged for the foliation \mathcal{Z}_2 constructed in Lemma 8.4.6, even though the curves $Z_{s,\vartheta}$ and $Z_{s',\vartheta}$ are not translations of one another unless $(\mathbb{R} \times T^2 \times [1, 2], \lambda)$ is a symplectization. In fact, they still project to the same annulus in $T^2 \times [1, 2]$ and, given any point in that annulus, their preimages $x \in Z_{s,\vartheta}$ and $x' \in Z_{s',\vartheta}$ become arbitrarily far apart in the s -coordinate when $|s' - s| \rightarrow +\infty$. These properties of the foliation \mathcal{Z}_2 are sufficient to make the proof of Lemma 8.4.8 work.

8.5 Completion of proof of Theorem 8.1.2

In this subsection we prove (2)–(4) of Theorem 8.1.2.

(2) The inclusion $\text{ECC}(\text{int}(V), \alpha_V) \subset \text{ECC}^\sharp(V, \alpha_V)$ is an inclusion of chain complexes since no J -holomorphic curve in $\mathbb{R} \times V$ with all positive ends in $\text{int}(V)$ can have a negative end on ∂V by the trapping lemma. Moreover, the map

$$\text{ECC}^\sharp(V, \alpha_V) \rightarrow \text{ECC}(\text{int}(V), \alpha_V), \quad \gamma \mapsto 0, \quad h'\gamma \mapsto \gamma,$$

where γ is an orbit set constructed from orbits in $\text{int}(V)$, induces an isomorphism of complexes

$$\text{ECC}^\sharp(V, \alpha_V) / \text{ECC}(\text{int}(V), \alpha_V) \simeq \text{ECC}(\text{int}(V), \alpha_V).$$

This is due to the fact that h' is a hyperbolic orbit and appears with exponent at most one in a generator of $\text{ECC}^\sharp(V, \alpha_V)$. From this we have an exact triangle

$$\begin{array}{ccc} \text{ECH}(\text{int}(V), \alpha_V) & \xrightarrow{\quad\quad\quad} & \text{ECH}(\text{int}(V), \alpha_V) \\ & \swarrow \quad \quad \quad \searrow & \\ & \text{ECH}^\sharp(V, \alpha_V) & \end{array}$$

which splits according to homology classes in $H_1(V)$. Then Proposition 8.3.2 implies that

$$\text{ECH}^\sharp(V, \alpha_V, n[S^1]) = 0$$

when $n \neq 0$.

It remains to show that $\text{ECH}^\sharp(V, \alpha_V, n[S^1]) \simeq 0$ for $n = 0$. Its chain complex $\text{ECC}^\sharp(V, \alpha_V, 0)$ is generated by h' and \emptyset . We claim that $\partial h' = \emptyset$. By Proposition 8.4.5, there is a finite-energy foliation \mathcal{Z}_1 on $(\mathbb{R} \times V, d(e^s \alpha_V))$ whose leaves (in $\mathbb{R} \times \text{int}(V)$) are J -holomorphic planes which are positively asymptotic to the Morse–Bott family on ∂V . This foliation constrains the J -holomorphic curves that limit to orbits on ∂V at the positive ends. Indeed, by Lemma 8.4.8, every holomorphic curve which is positively asymptotic to a simple Reeb orbit on ∂V and has no negative ends must be a plane in \mathcal{Z}_1 . The leaves of \mathcal{Z}_1 also contribute to the differential of $\text{ECC}(V, \alpha_V)$ since they are automatically transverse by Theorem 8.4.2. Hence $\partial h' = \emptyset$, which implies the vanishing of $\text{ECH}^\sharp(V, \alpha_V, 0)$.

(3) We define a filtration \mathcal{F} on $\text{ECC}(V, \alpha_V)$ as follows: Given an orbit set $(e')^m \gamma$, where γ does not have any e' -terms, we set

$$\mathcal{F}((e')^m \gamma) = m.$$

This defines an ascending filtration of chain complexes: since J -holomorphic maps to $\mathbb{R} \times V$ can have only positive ends at e' by the trapping lemma, the differential of $\text{ECC}(V, \alpha_V)$ cannot increase the exponent of e' . The E^1 -term of the associated spectral sequence is isomorphic to $\text{ECH}^\sharp(V, \alpha_V)$ at each filtration level. By (1), $\text{ECH}^\sharp(V, \alpha_V) = 0$, and the spectral sequence converges to 0.

(4) The restriction of \mathcal{F} to $\text{ECC}^b(V, \alpha_V)$ induces a filtration on $\text{ECC}^b(V, \alpha_V)$, which we still denote by \mathcal{F} . The E^1 -term of the spectral sequence for \mathcal{F} is isomorphic to

$$\bigoplus_{m=0}^{\infty} \text{ECH}(\text{int}(V), \alpha_V) \cdot (e')^m.$$

Since $\text{ECH}(\text{int}(V), \alpha_V) \simeq \mathbb{F}\{\emptyset\}$ by Theorem 8.1.2, the E^1 -term of the spectral sequence is $\mathbb{F}[e']$. All higher differentials vanish for degree reasons: recall that ECH has a $\mathbb{Z}/2$ grading in which generators with no hyperbolic orbits have even grading. Hence $E^1 = E^\infty$ is the graded group of the induced filtration on $\text{ECH}^b(V, \alpha_V)$. Since the filtration \mathcal{F} on $\text{ECC}^b(V, \alpha_V)$ is bounded below and exhaustive, the spectral sequence converges by [Weibel 1994, Theorem 5.5.5] and therefore $\text{ECH}^b(V, \alpha_V) \simeq \mathbb{F}[e']$.

9 Proof of Theorem 1.1.1

In this section we prove Theorem 1.1.1. The proof was greatly influenced by Michael Hutchings, who encouraged us to look for an appropriate filtration.

9.1 Intuitive idea behind Theorem 1.1.1

We briefly explain the intuitive idea behind Theorem 1.1.1. We recall that M denotes a connected, closed, oriented three-manifold and K is a null-homologous knot in M . Suppose for the moment that the contact form α on M , in a neighborhood $V \simeq D^2 \times S^1$ of K , is given by Example 6.2.3. In other words, the concentric tori $T_\rho \subset V$, $\rho \neq 0$, are foliated by Reeb orbits of irrational slope $1/\nu$. We would like to take the limit as $\nu \rightarrow 0$; in the limit ∂V is foliated by Reeb orbits of slope ∞ . Let us write $N = M - \text{int}(V)$. There should be a one-to-one correspondence, modulo \mathbb{R} -translations, between holomorphic curves u in $\mathbb{R} \times M$ of ECH index 1 which intersect the binding k times, and holomorphic curves u' in $\mathbb{R} \times N$ of ECH index 1 which have negative ends at an elliptic orbit e of slope ∞ with total multiplicity k . Also, as we take $\delta \rightarrow 0$, the Conley–Zehnder index of the binding, measured with respect to the longitudinal framing on V , ie the framing given by a Seifert surface Σ for K , goes to ∞ . This suggests that we should be able to effectively ignore the binding if we could take the limit.

The actual proof — at least the one we could find — is considerably more complicated, and uses three ingredients:

- (i) the calculation of ECH on the solid torus from Section 8,
- (ii) some understanding of holomorphic curves that project to a neighborhood of K , and
- (iii) a filtration on $ECC(M)$.

9.2 Description of the contact forms

We start with a description of the contact forms and their Reeb orbits on M that we use in the proof of Theorem 1.1.1. We fix a neighborhood $V \simeq D^2 \times S^1$ of K and decompose M as

$$M = N \cup (T^2 \times [1, 2]) \cup V.$$

Since K is an oriented null-homologous knot, there is a properly embedded oriented surface $S \subset N$ whose boundary $\partial S \subset \partial V$ is a longitude for K . On V we choose cylindrical coordinates (ρ, ϕ, θ) such that $\partial V = \{\rho = 1\}$ and $\partial S = \{\rho = 1, \phi = \phi_0\}$. On $T^2 \times [1, 2] \simeq (\mathbb{R}^2/\mathbb{Z}^2) \times [1, 2]$ we choose coordinates (ϑ, t, y) such that $(\vartheta, t, 2)$ is identified with $(\rho, \phi, \theta) = (1, 2\pi t, 2\pi\vartheta) \in \partial V$. We identify a neighborhood of ∂N in N with $T^2 \times [0, 1]$ such that $\partial N = T^2 \times \{1\}$ and the coordinates (ϑ, t, y) on $T^2 \times [0, 1]$ extend those on $T^2 \times [1, 2]$; similarly, we identify a neighborhood of ∂V in V with $T^2 \times [2, \frac{5}{2}]$.

We will work with an increasing sequence $L_i \rightarrow +\infty$ and a sequence of Morse–Bott contact forms α_i on M such that

- $\alpha_i|_N$ is a fixed Morse–Bott contact form α which is nondegenerate on $\text{int}(N)$ and its Reeb vector field is positively transverse to S ;
- $\alpha_i|_{T^2 \times [1, 2]}$ is a contact form α_{δ_i} as in Example 6.1.2 which is chosen so that all the Reeb orbits in $T^2 \times (1, 2)$ have action larger than L_i ; and
- $\alpha_i|_V = c_{\delta_i} \alpha_V$ for a fixed contact form α_V constructed as in Lemma 8.1.1 and a decreasing sequence c_{δ_i} which is bounded above by 1 and bounded below by a positive constant.

We also assume the following technical condition:

- There is a decreasing sequence $\epsilon_i \rightarrow 0$ such that α_i agrees with α_{i+1} on $N \cup (T^2 \times [1, 1 + \epsilon_i])$ and with a constant positive multiple of α_{i+1} on $V \cup (T^2 \times [2 - \epsilon_i, 2])$.

We will refer to $T^2 \times (1, 2)$ as the *no man’s land*.

The contact form α on N can be constructed using the techniques developed in [Colin and Honda 2005; Colin et al. 2011b]. The construction is described in Section 9.3.1 in the special case where K is the binding of an open book decomposition of M and N is the mapping torus of a diffeomorphism of S .

The contact forms α_i are Morse–Bott and all the Morse–Bott tori are of the form $T^2 \times \{y\}$ with $y \in [1, 2]$. In particular, $\partial N = T^2 \times \{1\}$ is foliated by a *negative* Morse–Bott family \mathcal{N}_1 and $\partial V = T^2 \times \{2\}$ by a *positive* Morse–Bott family \mathcal{N}_2 . Both families have infinite slope, ie the Reeb orbits on both tori are meridians of K .

We construct L_i -nondegenerate contact forms $\alpha'_i = f_i \alpha_i$, where the perturbing functions f_i are as in Section 4.5. We choose f_i so that the Morse–Bott family \mathcal{N}_1 corresponding to ∂N is perturbed into an elliptic orbit e and a hyperbolic orbit h , the Morse–Bott family \mathcal{N}_2 corresponding to ∂V is perturbed into a hyperbolic orbit h' and an elliptic orbit e' , no new closed orbits with action less than L_i are created, and $f_i \equiv 1$ in a neighborhood of all nondegenerate Reeb orbits of α_i with action less than L_i .

For all i we choose regular almost complex structures J_i adapted to α_i and J'_i adapted to α'_i such that all the J_i are fixed on the contact structure outside $T^2 \times [1 - \epsilon_i, 2 + \epsilon_i]$ and J'_i is an arbitrarily small perturbation of J_i .

We will also consider interpolating cobordisms $(\mathbb{R} \times M, \hat{\lambda}_i)$ from (M, α_i) to a rescaling of (M, α_{i+1}) and $(\mathbb{R} \times M, \hat{\lambda}'_i)$ from (M, α'_i) to a rescaling of (M, α'_{i+1}) . By construction, λ'_i is an arbitrarily small perturbation of λ_i . We fix compatible almost complex structures \hat{J}_i on $(\mathbb{R} \times M, \hat{\lambda}_i)$ and \hat{J}'_i on $(\mathbb{R} \times M, \hat{\lambda}'_i)$ such that they are both regular and \hat{J}'_i is an arbitrarily small perturbation of \hat{J}_i .

We assume that the perturbing functions are close enough to 1 that the following hold:

- (MB₁) For $k = 1, 2$, if γ_+ and γ_- are generators of $\text{ECC}^{L_i}(M, \alpha'_i)$ and $u \in \mathcal{M}_{J'_i}^{I=k}(\gamma_+, \gamma_-)$, then there is a corresponding $u_\infty \in \mathcal{M}_{J_i}^{\text{MB}, I=k}(\gamma_+, \gamma_-)$.
- (MB₀) If γ_+ and γ_- are generators of $\text{ECC}^{L_i}(M, \alpha'_i)$ and $\text{ECC}^{L_{i+1}}(M, \alpha'_{i+1})$, respectively, and $u \in \mathcal{M}_{\hat{J}'_i}^{I=0}(\gamma_+, \gamma_-)$, then there is a corresponding $u_\infty \in \mathcal{M}_{\hat{J}_i}^{\text{MB}, I=0}(\gamma_+, \gamma_-)$.

Recall from Definition 4.2.2 that $\mathcal{M}_J^{\text{MB}}(\gamma_+, \gamma_-)$ denotes the set of Morse–Bott J -holomorphic buildings from γ_+ to γ_- .

For reference we enumerate the main properties of the Reeb vector fields of the contact forms α_i and their perturbations α'_i :

- (1) α_i is Morse–Bott and α'_i is L_i -nondegenerate.
- (2) R_{α_i} is positively transverse to $S \subset N$ and the meridian disks in $\text{int}(V)$.
- (3) $\alpha_i|_N = \alpha$ and $\alpha_i|_V = c_{\delta_i} \alpha_V$, where the sequence c_{δ_i} is decreasing, bounded above by 1 and bounded below by a positive constant and the contact form α_V is constructed as in Lemma 8.1.1.
- (4) α_i and α_{i+1} coincide on $N \cup (T^2 \times [1, 1 + \epsilon_i])$ and are constant multiples of one another on $V \cup (T^2 \times [2 - \epsilon_i, 2])$, where $\epsilon_i \rightarrow 0$ is a decreasing sequence.
- (5) The Reeb orbits of α_i in the no man’s land come in Morse–Bott families of large negative slope and their action is bounded below by L_i .
- (6) There are concentric solid tori $V_0 \subset V_1 \subset \dots \subset V$ such that ∂V_j for $j = 0, 1, \dots$ is foliated by dense Reeb orbits of irrational slope $r_j > 0$ with $\lim_{j \rightarrow \infty} r_j = +\infty$ for any contact form α_i .
- (7) ∂N is foliated by a negative Morse–Bott family \mathcal{N}_1 of Reeb orbits of α_i of slope ∞ . After perturbation, \mathcal{N}_1 becomes a pair of orbits e and h . Their Conley–Zehnder indices with respect to the framing coming from ∂N (given by $T(\partial N) \cap \xi$) are $\mu(e) = -1$ and $\mu(h) = 0$.

- (8) ∂V is foliated by a positive Morse–Bott family \mathcal{N}_2 of slope ∞ . After perturbation, \mathcal{N}_2 becomes a pair of orbits e' and h' . Their Conley–Zehnder indices with respect to the framing coming from ∂V are $\mu(e') = 1$ and $\mu(h') = 0$.

9.3 Construction of the contact forms

In this subsection we construct the contact forms α_i when K is the binding of an open book decomposition. In this case N is the mapping torus of a diffeomorphism $h: S \rightarrow S$ such that $h|_{\partial S} = \text{id}$. This means that

$$N = (S \times [0, 1]) / (x, 1) \sim (h(x), 0),$$

where $x \in S$ and t is the coordinate for $[0, 1]$. Using the coordinates (θ, ϕ) from Section 9.2 we identify the isotopy classes of simple closed curves in ∂N (and in all parallel tori) with rational numbers so that the meridian has slope ∞ and ∂S has slope 0.

Remark 9.3.1 The above slope convention is the same as the usual surgery convention for performing surgery along the binding.

9.3.1 Construction of the contact form on N We take a 1-form β on S such that $\omega = d\beta$ is a positive area form on S and $\beta = cy \, d\theta$ in a neighborhood $N(\partial S) \subset S$ of ∂S . Here $c > 0$ is a small constant and $N(\partial S)$ is identified with $[1 - \delta, 1] \times \mathbb{R}/\mathbb{Z}$ with coordinates (y, θ) .

We assume that the diffeomorphism $h: S \xrightarrow{\sim} S$ satisfies $h|_{N(\partial S)} = \text{id}$. Let $\text{Symp}(S, \partial S, \omega)$ be the group of symplectomorphisms of (S, ω) which restrict to the identity on a neighborhood of ∂S . By Moser’s lemma, there is an isotopy of h relative to ∂S such that the resulting diffeomorphism — also called h by abuse of notation — is in $\text{Symp}(S, \partial S, \omega)$.

Lemma 9.3.2 (Giroux) *Given $h \in \text{Symp}(S, \partial S, \omega)$, there exists an isotopy $\{h_t\}_{t \in [0, 1]}$ in $\text{Symp}(S, \partial S, \omega)$ such that $h_0 = h$ and $h_1^* \beta - \beta = df$ for some positive function f on S .*

Proof Let $\mu = h^* \beta - \beta$ and let Y be the vector field which satisfies $i_Y \omega = -\mu$. By Cartan’s formula, we compute that $\mathcal{L}_Y \omega = i_Y d\omega + d(i_Y \omega) = -d\mu = 0$ and $\mathcal{L}_Y \mu = i_Y d\mu + d(i_Y \mu) = 0$. Hence the flow ϕ_t of Y preserves ω and μ . Moreover, ϕ_t is equal to the identity near ∂S , where $\mu = 0$.

Now let $h_t = h \circ \phi_t$. We then compute that

$$\frac{d}{dt} h_t^* \beta = \phi_t^* (\mathcal{L}_Y h^* \beta) = d(\phi_t^* (i_Y h^* \beta)) + \phi_t^* (i_Y d(h^* \beta)) = dg_t + \phi_t^* (i_Y \omega) = dg_t - \phi_t^* \mu = dg_t - \mu,$$

where $g_t = \phi_t^* (i_Y h^* \beta)$. Hence

$$(9-3-1) \quad \frac{d}{dt} h_t^* \beta = dg_t + \beta - h^* \beta.$$

Integrating (9-3-1) yields $h_1^* \beta - \beta = df$, where $f = \int_0^1 g_t \, dt + C$ for a sufficiently large constant C . \square

By Lemma 9.3.2, we assume that $h \in \text{Symp}(S, \partial S, \omega)$ satisfies $h^*\beta - \beta = df$. Next we construct a contact form on N whose corresponding Reeb vector field is transverse to the fibers and has first return map h .

Lemma 9.3.3 *Let h be a diffeomorphism in $\text{Symp}(S, \partial S, \omega)$ which satisfies $h^*\beta - \beta = df$ for some function f on S . Then there is a contact form $\alpha = f_t dt + \beta_t$ on N , where f_t is a family of positive functions on S and β_t is a family of 1-forms on S , such that the corresponding Reeb vector field R_α is transverse to all the fibers $S \times \{t\}$ and h is the first return map of R_α .*

For a more complete discussion of the realizability of surface symplectomorphisms as the first return map of a Reeb vector field, we refer the reader to [Colin et al. 2008].

Proof Consider the 1-form $\alpha = f_t dt + \beta_t$ on $S \times [0, 1]$, where f_t is to be determined, $\beta_0 = \beta$, $\beta_1 = h^*\beta$, and

$$\beta_t = \chi(t)\beta_1 + (1 - \chi(t))\beta_0$$

interpolates between β_0 and β_1 . Here we take $\chi: [0, 1] \rightarrow [0, 1]$ such that $\chi(0) = 0$, $\chi(1) = 1$, $d\chi(t)/dt = \dot{\chi}(t) \geq 0$ and χ is constant near 0 and 1.

Using the condition $h^*\beta - \beta = d_S f$, we verify that the 1-form $\dot{\beta}_t$ is exact on S :

$$\dot{\beta}_t = \dot{\chi}(t)(\beta_1 - \beta_0) = \dot{\chi}(t)(d_S f) = d_S(\dot{\chi}(t)f).$$

Here d_S is the exterior derivative on S . We then take $f_t = \dot{\chi}(t)f + c$, where c is an arbitrary positive constant such that $f_t > 0$ (and is different from the c in $\beta = cy d\theta$ from the beginning of Section 9.3.1). Then $\dot{\beta}_t = d_S f_t$. Since χ is constant near $t = 0$ and $t = 1$, f_t is also constant, and so is β_t . In particular, $h^*f_1 = f_0$.

We now compute that

$$d\alpha = d_S f_t \wedge dt + d_S \beta_t + dt \wedge \dot{\beta}_t = d_S f_t \wedge dt + \omega + dt \wedge d_S f_t = \omega.$$

Hence α is a contact form, its Reeb vector field is parallel to ∂_t on $S \times [0, 1]$, and its first return map is h . \square

Now we make a slight modification to α so that ∂N becomes a *negative* Morse–Bott family — one that behaves like a sink for J -holomorphic maps in $\mathbb{R} \times N$.

On $T_1 = \partial N$, the germ of α is given by $f(y) dt + g(y) d\theta$, where $f(y) = C$ and $g(y) = cy$. Here $c > 0$ is a small constant and $C > 0$ is a large constant. We extend α to $T^2 \times [1, 1 + \varepsilon]$ by extending $(f(y), g(y))$ to $y \in [1, 1 + \varepsilon]$ as follows:

- (1) $(f(y), g(y))$ satisfies (6-1-2).
- (2) $(f(y), g(y))$ for $y \in [1, 1 + \varepsilon]$ is close to $(f(1), g(1))$.
- (3) $(f(y), g(y)) = (f(1 + \varepsilon) + (y - (1 + \varepsilon))^2, g(1 + \varepsilon) + (y - (1 + \varepsilon)))$ near $y = 1 + \varepsilon$.

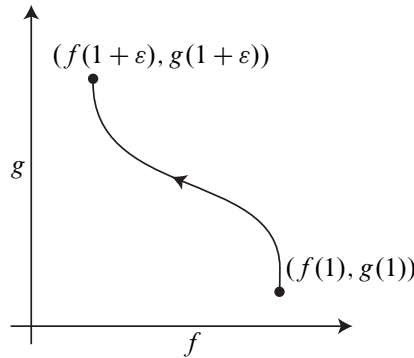

Figure 4: Trajectory of $(f(y), g(y))$. The f -axis and g -axis do not necessarily intersect at $(0, 0)$ in this figure.

See Figure 4. In particular, condition (3) implies that $(f'(1 + \epsilon), g'(1 + \epsilon))$ is parallel to $(0, 1)$. Hence $T_{1+\epsilon}$ is foliated by a Morse–Bott family of Reeb orbits of slope ∞ . We write α for the extension of α to $N \cup (T^2 \times [1, 1 + \epsilon])$.

We now consider the deformation retract

$$\phi: N \cup (T^2 \times [1, 1 + \epsilon]) \xrightarrow{\sim} N,$$

obtained by flowing along the vector field $X = -a(y)\partial_y$, where $a(y) = 1$ on $T^2 \times [1, 1 + \epsilon]$ and damps out to zero on $T^2 \times [1 - \epsilon, 1]$. Finally, we perturb $\phi_*\alpha$ on N so that all Reeb orbits in $\text{int}(N)$ become nondegenerate, while keeping ∂N Morse–Bott. *The resulting form will be called α in the rest of the paper.*

9.3.2 Extension to M The contact form α has the form

$$\alpha = (b + (y - 1)) d\theta + (a + (y - 1)^2) dt$$

in some collar $T^2 \times [1 - \epsilon, 1]$ of ∂N . Here ϵ is different from the ϵ in Section 9.3.1.

Choose a decreasing sequence of irrational numbers $\delta_i \rightarrow 0$ and a contact form α_{δ_i} on $T^2 \times [1, 2]$ for each i as in Example 6.1.2 with $f(1) = a$ and $g(1) = b$. Then α on N and α_{δ_i} on $T^2 \times [1, 2]$ glue to a smooth contact form on $N \cup (T^2 \times [1, 2])$. Moreover, there is an increasing sequence $L_i \rightarrow +\infty$ such that all Reeb orbits of α_{δ_i} in $T^2 \times (1, 2)$ have action greater than L_i .

Fix a contact form $\alpha_{f,g}$ on $V \simeq D^2 \times S^1$ as in Example 6.2.4. For each i , a multiple of $\alpha_{f,g}$ glues smoothly to the contact form α_{δ_i} on $T^2 \times [1, 2]$. Let c_{δ_i} be the scaling factor. Then α_{δ_i} glues smoothly also to $c_{\delta_i}\alpha_V$, where α_V is the contact form obtained by applying the construction of Lemma 8.1.1 to $\alpha_{f,g}$. By putting all three pieces together we obtain the contact forms α_i on M .

9.4 The filtrations \mathcal{F}_i

For each i we define a filtration \mathcal{F}_i on $\text{ECC}^{L_i}(M, \alpha'_i)$. We first identify $\text{ECC}^{L_i}(M, \alpha'_i)$, as a vector space, with a subspace of

$$\text{ECC}(V, \alpha_V) \otimes \text{ECC}(N, \alpha).$$

This is possible because the Reeb orbits of α'_i in the no man's land have actions greater than L_i and those in V coincide with the Reeb orbits of α_V , up to reparametrization. The generators of $\text{ECC}^{L_i}(V, \alpha'_i)$ will be denoted by $\gamma \otimes \Gamma$, where $\gamma \in \text{ECC}(V, \alpha_V)$ and $\Gamma \in \text{ECC}(N, \alpha)$. Choose an identification

$$\eta: H_1(V; \mathbb{Z}) \xrightarrow{\sim} \mathbb{Z}$$

so that the homology class of the null-homologous knot K is mapped to 1. Then we define the ascending filtration $\mathcal{F}_i: \text{ECC}^{L_i}(M, \alpha'_i) \rightarrow \mathbb{Z}^{\geq 0}$ as

$$\mathcal{F}_i \left(\sum_n \gamma_n \otimes \Gamma_n \right) = \max_n \eta([\gamma_n]).$$

We define \mathcal{F}_i^p as $\mathcal{F}_i^p = \{x \in \text{ECC}^{L_i}(M, \alpha'_i) : \mathcal{F}_i(x) \leq p\}$. Note that these filtrations are uniformly bounded below because $\mathcal{F}_i^p = 0$ for $p < 0$.

Lemma 9.4.1 *Let $u: F \rightarrow \mathbb{R} \times M$ be a J'_i -holomorphic map which is asymptotic to $\gamma \otimes \Gamma$ at the positive end and to $\gamma' \otimes \Gamma'$ at the negative end. Then*

$$\mathcal{F}_i(\gamma \otimes \Gamma) \geq \mathcal{F}_i(\gamma' \otimes \Gamma').$$

Proof By (MB₁) there is a J_i -holomorphic Morse–Bott building from $\gamma \otimes \Gamma$ to $\gamma' \otimes \Gamma'$. Let $\bar{u}: \bar{F} \rightarrow \mathbb{R} \times M$ be the holomorphic part of this building — which may be disconnected because α_i is not necessarily nice — and denote the projection to M by \bar{u}_M .

We will use the tori $T_n = \partial V_n$ in V from Lemma 8.1.1 to constrain the ends of \bar{u} . We recall that T_n is foliated by dense Reeb orbits of irrational slope r_n with $r_n \rightarrow +\infty$. Let δ_n be the homology class of $\bar{u}_M(\bar{F}) \cap T_n$, oriented as the boundary of $\bar{u}_M(\bar{F}) \cap V_n$. If n is sufficiently large, then all the orbits in γ and γ' that are not in the Morse–Bott family on ∂V are contained in V_n . Hence the sequence δ_n is constant for $n \gg 0$ and $\eta(\delta_n) = \eta(\gamma') - \eta(\gamma)$.

Regarding both δ_n and r_n as homology classes in $H_1(T_n; \mathbb{R})$ and orienting T_n as the boundary of V_n , for $n \gg 0$ we obtain $\delta_n \cdot r_n \geq 0$ by the positivity of intersections in dimension three (Lemma 5.2.2). Taking the limit $n \rightarrow \infty$ and using the fact that the sequence r_n converges to the slope of the Reeb vector field on ∂V , we obtain $\eta(\delta_n) \leq 0$ for $n \gg 0$. This implies $\mathcal{F}_i(\gamma \otimes \Gamma) \geq \mathcal{F}_i(\gamma' \otimes \Gamma')$. \square

Corollary 9.4.2 *The differential of $\text{ECC}^{L_i}(M, \alpha'_i)$ respects the filtration \mathcal{F}_i .*

For each i the filtration \mathcal{F}_i induces a spectral sequence $E^r(\mathcal{F}_i)$ which converges to $\text{ECH}^{L_i}(M, \alpha'_i)$. The terms $E^0(\mathcal{F}_i)$ correspond to the graded complexes associated to \mathcal{F}_i and can be identified (as vector spaces) with subspaces of $\text{ECC}(V, \alpha_V) \otimes \text{ECC}(N, \alpha_N)$. The differential ∂_0 on $E^0(\mathcal{F}_i)$ is the filtration-preserving component of the differential on $\text{ECC}^{L_i}(M, \alpha'_i)$. Every sheet $E^r(\mathcal{F}_i)$ has a grading coming from \mathcal{F}_i , and the component in degree p of $E^r(\mathcal{F}_i)$ will be denoted by $E_p^r(\mathcal{F}_i)$.

9.5 Description of the differential on $E^0(\mathcal{F}_i)$

In this subsection we compute the differential ∂_0 on $E^0(\mathcal{F}_i)$ using Morse–Bott techniques. This is possible, in spite of the fact that the contact forms α_i are not necessarily nice, because of the following lemma:

Lemma 9.5.1 *Let \tilde{u} be a Morse–Bott building from $\gamma \otimes \Gamma$ to $\gamma' \otimes \Gamma'$ in the symplectization of (M, α_i) and let u be its holomorphic part. If u has a positive end at ∂N or a negative end at ∂V , then $\mathcal{F}_i(\gamma' \otimes \Gamma') < \mathcal{F}_i(\gamma \otimes \Gamma)$.*

Proof We recall that K denotes the core of V and that $S \subset N$ is a properly embedded surface such that ∂S defines a longitude of K . In the case of an open book decomposition, K is the binding and S is a page.

Let $\bar{U} \simeq T^2 \times [1 - \epsilon, 2 + \epsilon] \subset M$ be a small neighborhood of the no man’s land $T^2 \times [1, 2]$ such that u has no ends at Reeb orbits intersecting \bar{U} , except at orbits in \mathcal{N}_1 or \mathcal{N}_2 . Assume without loss of generality that the ends of u limit to distinct orbits η_1, \dots, η_n . Then we let U_k be a small tubular neighborhood of η_k for $k = 1, \dots, n$ and let $U = \bar{U} - (U_1 \cup \dots \cup U_n)$. Let $B_k = -\partial U_k$ for $k = 1, \dots, n$, $B_0 = (\partial \bar{U}) \cap V$ and $B_{n+1} = (\partial \bar{U}) \cap N$. We orient each B_k , for $k = 0, \dots, n + 1$, using the boundary orientation of U .

On each B_k for $k = 0, \dots, n + 1$, we choose an oriented basis of curves (μ_k, ν_k) as follows: On B_0 and B_{n+1} we choose μ_0 and μ_{n+1} so that they are longitudes of K coming from S and ν_0 and ν_{n+1} so that they are meridians of K . On each B_k for $k = 1, \dots, n$, we choose ν_k so that it is the longitude of the Reeb orbit in U_k induced by the Morse–Bott torus (which is either ∂N or ∂V) and μ_k so that it is a meridian of U_k . The curves ν_k for $k = 0, \dots, n + 1$ are oriented by the vector field ∂_t and the curves μ_k for $k = 0, \dots, n + 1$ are oriented by $\mu_k \cdot \nu_k = 1$.

By abuse of notation, we identify the oriented curves μ_k and ν_k with their homology classes in $H_1(U; \mathbb{Z})$. With this convention, $\nu_0 = \nu_1 = \dots = \nu_{n+1}$ and $\mu_0 + \mu_1 + \dots + \mu_{n+1} = 0$. Moreover, these relations generate the kernel of the map

$$\bigoplus_{k=0}^{n+1} H_1(B_k; \mathbb{Z}) \rightarrow H_1(U; \mathbb{Z})$$

induced by the inclusion. Let $C = \text{Im}(u_M) \cap U$. Then $\partial C = \delta_0 + \dots + \delta_{n+1}$, where $\delta_k \subset B_k$ is given the orientation induced by C . We will view δ_k either as an element of $H_1(B_k; \mathbb{Z})$ or as an element of $H_1(U; \mathbb{Z})$. Then $\delta_0 + \dots + \delta_{n+1} = 0$ in $H_1(U; \mathbb{Z})$. For each k we write $\delta_k = a_k \mu_k + b_k \nu_k$.

By the trapping lemma and the positivity of intersections in dimension three, we have $\delta_k \cdot \nu_k \geq 0$ for $k = 1, \dots, n$, because the curves ν_k can be represented by Reeb orbits. (Here we are using a variation of Lemma 5.2.2 which is an immediate consequence of the positivity of intersections in dimension four.) Then, for all $k = 1, \dots, n$, $a_k \geq 0$; moreover, if δ_k corresponds either to a positive end at T_1 or to a

negative end at T_2 , then $a_k > 0$. The relations in $H_1(U; \mathbb{Z})$ among the curves μ_k and ν_k imply that $a_0 = \dots = a_{n+1}$, so $a_0 > 0$ if u has either a positive end at ∂N or a negative end at ∂V . Then

$$a_0 = \eta(\gamma) - \eta(\gamma') = \mathcal{F}_i(\gamma \otimes \Gamma) - \mathcal{F}_i(\gamma' \otimes \Gamma') > 0. \quad \square$$

Corollary 9.5.2 *Let $\gamma \otimes \Gamma$ and $\gamma' \otimes \Gamma'$ be generators of $\text{ECC}^{L_i}(M, \alpha'_i)$. If $\mathcal{F}_i(\gamma \otimes \Gamma) = \mathcal{F}_i(\gamma' \otimes \Gamma')$ and \tilde{u} is a Morse–Bott building with $I(\tilde{u}) = 1$ in the symplectization of (M, α_i) from $\gamma \otimes \Gamma$ to $\gamma' \otimes \Gamma'$, then the holomorphic part of \tilde{u} has at most one nontrivial irreducible component.*

Proof Let u be the holomorphic part of \tilde{u} . By Lemma 9.5.1, all ends of u at ∂N are negative and all ends of u at ∂V are positive. Then the structure of \tilde{u} is simple enough that the argument of Lemma 7.1.2 implies that u has a unique irreducible component which is not a connector. \square

Corollary 9.5.2 implies that, for the purpose of computing the differential ∂_0 of $E^0(\mathcal{F}_i)$, we can use Morse–Bott theory as if the contact forms α_i were nice.

In order to describe the differential concisely we introduce the following notation. Given two orbit sets $\gamma' = \prod \gamma_i^{m'_i}$ and $\gamma = \prod \gamma_i^{m_i}$ (in multiplicative notation), we set $\gamma/\gamma' = \prod \gamma_i^{m_i - m'_i}$ if $m'_i \leq m_i$ for all i ; otherwise we set $\gamma/\gamma' = 0$. We also call $T_1 = \partial N$ and $T_2 = \partial V$.

We now prove the following lemma, which describes the differential ∂_0 on E^0 in some detail:

Lemma 9.5.3 *After identifying $E_0(\mathcal{F}_i)$, as a vector space, with a subspace of $\text{ECC}(V, \alpha_V) \otimes \text{ECC}(N, \alpha)$, the differential ∂_0 is given by*

$$(9-5-1) \quad \partial_0(\gamma \otimes \Gamma) = (\partial_V \gamma) \otimes \Gamma + (\gamma/e') \otimes h\Gamma + (\gamma/h') \otimes e\Gamma + \gamma \otimes (\partial_N \Gamma).$$

Here γ is an orbit set of V ; if h divides Γ , then $h\Gamma$ is understood to be 0; and ∂_X is the differential on the subset $X \subset M$.

Proof Corollary 9.5.2 and Proposition 4.4.7 imply that ∂_0 on $E^0(\mathcal{F}_i)$ can be computed by counting $I = 1$ very nice Morse–Bott buildings in the symplectization of (M, α_i) which do not decrease the filtration level.

The differential ∂_0 does not count holomorphic curves which cross $\mathbb{R} \times T_1 = \mathbb{R} \times \partial N$ or $\mathbb{R} \times T_2 = \mathbb{R} \times \partial V$: Indeed, if u is a holomorphic curve which contributes to ∂_0 and u_M its projection to M , then the homology classes $[\text{Im}(u_M) \cap T_{1 \pm \varepsilon}] \in H_1(T_{1 \pm \varepsilon})$ and $[\text{Im}(u_M) \cap T_{2 \pm \varepsilon}] \in H_1(T_{2 \pm \varepsilon})$ (for $\varepsilon > 0$ small) have slope ∞ , and we apply the blocking lemma (Lemma 5.2.3(2)). This still allows for the possibility of curves that are negatively asymptotic to orbits of T_1 or positively asymptotic to orbits in T_2 . (Curves which are positively asymptotic to orbits of T_1 or negatively asymptotic to orbits of T_2 are ruled out by Lemma 9.5.1 because they have been shown to decrease the filtration level.) Such curves are contained in $\mathbb{R} \times V$, $\mathbb{R} \times T^2 \times [1, 2]$, or $\mathbb{R} \times N$ by a combination of the trapping lemma (Lemma 5.3.2) and the blocking lemma (Lemma 5.2.3).

Curves in $\mathbb{R} \times V$ contribute to the term $(\partial_V \gamma) \otimes \Gamma$, while curves in $\mathbb{R} \times N$ contribute to $\gamma \otimes \partial_N(\Gamma)$. Note that there are two cylinders from e' to h' and two cylinders from h to e corresponding to gradient trajectories on \mathcal{N}_2 and \mathcal{N}_1 ; these give $\partial_0(e' \otimes 1) = 0$ and $\partial_0(1 \otimes h) = 0$.

Next we consider curves in $\mathbb{R} \times \text{int}(T^2 \times [1, 2])$. By Lemma 8.4.8, the only somewhere-injective curves in $\mathbb{R} \times \text{int}(T^2 \times [1, 2])$ are the cylinders $Z_{s,\theta}$ defined in Lemma 8.4.6. (Remember that we are ignoring the curves which are asymptotic to the orbits in $\text{int}(T^2 \times [1, 2])$ because they have action larger than L_i .) By Lemma 8.4.7, the cylinders $Z_{s,\theta}$ satisfy automatic transversality as long as at least one of the ends is treated as unconstrained. Branched covers of $Z_{s,\theta}$ of degree > 1 are not counted in the differential since they have $I > 1$ (after augmenting them with cylinders corresponding to gradient trajectories). Modulo translations in the s -direction, there is a unique $I = 1$ Morse–Bott building from h' to e , which gives the term $(\gamma/h') \otimes e\Gamma$, and a unique $I = 1$ Morse–Bott building from e' to h , which gives the term $(\gamma/e') \otimes h\Gamma$ (adding trivial cylinders to these buildings does not change their ECH index because they satisfy the admissibility conditions from [Hutchings 2002, Proposition 7.1, equations (23) and (24)]). \square

9.6 Direct limit

In this subsection we use a direct limit argument to exclude the Reeb orbits in the no man’s land from the complex computing $\text{ECH}(M)$. The limit will be compatible with the filtrations \mathcal{F}_i , so the end result will be a spectral sequence E^r converging to $\text{ECH}(M)$. The following lemma is immediate from Corollary 3.2.3 and the construction of the contact forms α'_i :

Lemma 9.6.1 *For an appropriate choice of contact forms α'_i and action thresholds L_i , we have*

$$\text{ECH}(M) = \lim_{i \rightarrow \infty} \text{ECH}^{L_i}(M, \alpha'_i).$$

The direct limit is taken with respect to maps

$$\Phi_i : \text{ECH}^{L_i}(M, \alpha'_i) \rightarrow \text{ECH}^{L_{i+1}}(M, \alpha'_{i+1})$$

induced by interpolating cobordisms via Lemma 3.1.7.

Lemma 9.6.2 *The map Φ_i is induced by a noncanonical chain map*

$$\widehat{\Phi}_i : \text{ECC}^{L_i}(M, \alpha'_i) \rightarrow \text{ECC}^{L_{i+1}}(M, \alpha'_{i+1}), \quad \gamma \otimes \Gamma \mapsto \gamma \otimes \Gamma + \mathbf{r}(\gamma \otimes \Gamma),$$

where $\mathcal{F}_{i+1}(\mathbf{r}(\gamma \otimes \Gamma)) < \mathcal{F}_{i+1}(\gamma \otimes \Gamma)$.

Proof The map Φ_i is induced by an interpolating cobordism from α'_i to (a rescaling of) α'_{i+1} . We degenerate this cobordism into a two-level cobordism such that the top level interpolates from $\alpha'_i = f_i \alpha_i$ to $f_{i+1} \alpha_i$ and the bottom level interpolates from $f_{i+1} \alpha_i$ to $\alpha'_{i+1} = f_{i+1} \alpha_{i+1}$. Then $\Phi_i = \Phi'_i \circ \Phi''_i$ by Theorem 3.1.2, where

$$\Phi''_i : \text{ECH}^{L_i}(M, \alpha'_i) \rightarrow \text{ECH}^{L_i}(M, f_{i+1} \alpha_i), \quad \Phi'_i : \text{ECH}^{L_i}(M, f_{i+1} \alpha_i) \rightarrow \text{ECH}^{L_{i+1}}(M, \alpha'_{i+1}).$$

The maps Φ'_i and Φ''_i are induced by noncanonical chain maps $\widehat{\Phi}'_i$ and $\widehat{\Phi}''_i$. By Proposition 4.5.5 we can assume that $\widehat{\Phi}''_i$ is the identity map.

Next we claim that the filtration-nondecreasing part of $\widehat{\Phi}'_i$ only counts trivial cylinders. Let $([0, 1] \times M, \lambda'_i)$ be an interpolating cobordism from $f_{i+1}\alpha_i$ to α'_{i+1} and $(\mathbb{R} \times M, \widehat{\lambda}'_i)$ its completion. By Theorem 3.1.2, $\widehat{\Phi}'_i$ is “supported” on the $I = 0$ holomorphic buildings of $(\mathbb{R} \times M, \widehat{\lambda}'_i)$. We are assuming that $\widehat{\lambda}'_i$ is sufficiently close to $\widehat{\lambda}_i$, where $([0, 1] \times M, \lambda_i)$ is an interpolating cobordism from α_i to α_{i+1} and $(\mathbb{R} \times M, \widehat{\lambda}_i)$ is its completion. Hence, by (MB₀), if $\langle \widehat{\Phi}'_i(\gamma \otimes \Gamma), \gamma' \otimes \Gamma' \rangle \neq 0$, then there is a Morse–Bott building in $(\mathbb{R} \times M, \widehat{\lambda}_i)$ connecting $\gamma \otimes \Gamma$ to $\gamma' \otimes \Gamma'$. Since the 2-form $d\lambda_i$ agrees with a symplectization on a neighborhood of $\mathbb{R} \times (N \cup V)$, we can repeat the argument of Lemma 9.4.1 to show that $\mathcal{F}_i(\gamma \otimes \Gamma) \geq \mathcal{F}_{i+1}(\gamma' \otimes \Gamma')$. Moreover, if $\mathcal{F}_i(\gamma \otimes \Gamma) = \mathcal{F}_{i+1}(\gamma' \otimes \Gamma')$, then the holomorphic buildings in $(\mathbb{R} \times M, \widehat{\lambda}_i)$ cannot cross the no man’s land by Lemma 8.4.6 and Remark 8.4.9. Therefore they are contained in the part of the cobordism $(\mathbb{R} \times M, \widehat{\lambda}_i)$ which is diffeomorphic to a symplectization. This implies the claim. \square

Lemma 9.6.3 *The chain maps $\widehat{\Phi}_i : \text{ECC}^{L_i}(M, \alpha'_i) \rightarrow \text{ECC}^{L_{i+1}}(M, \alpha'_{i+1})$ induce chain maps $E^r(\mathcal{F}_i) \rightarrow E^r(\mathcal{F}_{i+1})$. The direct limits*

$$E^r(\mathcal{F}) = \lim_{i \rightarrow \infty} E^r(\mathcal{F}_i)$$

form a spectral sequence converging to $\text{ECH}(M)$. The page $E^0(\mathcal{F})$ can be identified, as a vector space, with $\text{ECC}(V, \alpha) \otimes \text{ECC}(N, \alpha)$ and the differential ∂_0 on $E^0(\mathcal{F})$ is described by (9-5-1).

Proof By Lemma 9.6.2, the continuation maps $\widehat{\Phi}_i$ are morphisms of chain complexes. Since the construction of the spectral sequence associated to a filtered complex is functorial (see [Weibel 1994, Proposition 5.9.2]), the maps $\widehat{\Phi}_i$ induce a morphism of spectral sequences

$$E^r(\mathcal{F}_i) \rightarrow E^r(\mathcal{F}_{i+1}).$$

We define $E^r(\mathcal{F}) = \lim_{i \rightarrow \infty} E^r(\mathcal{F}_i)$. Since direct limit is an exact functor from the category of directed systems of abelian groups to the category of abelian groups (see for example [Weibel 1994, Theorem 2.6.15]), the limits $E^r(\mathcal{F})$ still form a spectral sequence.

We claim now that $E^\infty(\mathcal{F}) = \lim_{i \rightarrow \infty} E^\infty(\mathcal{F}_i)$. First we recall the definition of the E^∞ term of a spectral sequence: on E^1 there is a sequence of subgroups

$$\{0\} = B^1 \subset B^2 \dots \subset B^r \subset \dots \subset Z^r \subset \dots \subset Z^2 \subset Z^1 = E^1$$

such that $E^r \simeq Z^r / B^r$; then we define

$$Z^\infty = \bigcap_{r \geq 1} Z^r, \quad B^\infty = \bigcup_{r \geq 1} B^r \quad \text{and} \quad E^\infty = Z^\infty / B^\infty.$$

By going through the construction of the spectral sequence, one can see that

$$B^r(\mathcal{F}) = \lim_{i \rightarrow \infty} B^r(\mathcal{F}_i) \quad \text{and} \quad Z^r(\mathcal{F}) = \lim_{i \rightarrow \infty} Z^r(\mathcal{F}_i)$$

because the direct limit is an exact functor. (The description of B^r and Z^r given in [Weibel 1994, Exercise 5.9.1] can be useful to prove this.)

Then, in order to prove the claim, it is enough to prove that

$$(9-6-1) \quad \lim_{i \rightarrow \infty} \left(\bigcup_{r \geq 1} B^r(\mathcal{F}_i) \right) = \bigcup_{r \geq 1} \left(\lim_{i \rightarrow \infty} B^r(\mathcal{F}_i) \right),$$

$$(9-6-2) \quad \lim_{i \rightarrow \infty} \left(\bigcap_{r \geq 1} Z^r(\mathcal{F}_i) \right) = \bigcap_{r \geq 1} \left(\lim_{i \rightarrow \infty} Z^r(\mathcal{F}_i) \right).$$

Equation (9-6-1) is not problematic because direct limits commute with countable unions. In fact countable unions can themselves be seen as direct limits, and direct limits commute as a consequence of their universal property [Lang 2002, Exercise 20]. On the other hand, in general, direct limits do not commute with infinite intersections, so we need more work to prove (9-6-2).

The spectral sequence of a filtered complex has a grading coming from the filtration: we can decompose $E^r(\mathcal{F}_i) = \bigoplus E_p^r(\mathcal{F}_i)$, $B^r(\mathcal{F}_i) = \bigoplus B_p^r(\mathcal{F}_i)$ and $Z^r(\mathcal{F}_i) = \bigoplus Z_p^r(\mathcal{F}_i)$. Since $\mathcal{F}_i^p = 0$ if $p < 0$, it follows from the construction of the spectral sequence that $Z_p^\infty(\mathcal{F}_i) = Z_p^r(\mathcal{F}_i)$ provided that $r \geq p$. (Again [Weibel 1994, Exercise 5.9.1] can be useful here.) Taking the direct limit, we obtain that $\lim_{i \rightarrow \infty} E_p^\infty(\mathcal{F}_i) = E_p^\infty(\mathcal{F})$ and this proves the claim.

The filtrations \mathcal{F}_i induce filtrations on $\text{ECH}^{L_i}(M, \alpha'_i)$; taking direct limits we obtain a filtration on $\text{ECH}(M)$ whose the graded group is the limit of the graded groups of the filtrations on $\text{ECH}^{L_i}(M, \alpha'_i)$ (again because direct limit is an exact functor). Since the filtrations \mathcal{F}_i are bounded below and exhaustive, the classical convergence theorem [Weibel 1994, Theorem 5.5.5] implies that $E^r(\mathcal{F}_i)$ converges to $\text{ECH}^{L_i}(M, \alpha'_i)$ (ie $E^\infty(\mathcal{F}_i)$ is isomorphic to the graded group of $\text{ECH}^{L_i}(M, \alpha'_i)$). Taking a direct limit, we then conclude that $E^r(\mathcal{F})$ converges to $\text{ECH}(M)$. \square

Here the notation $E^r(\mathcal{F})$ does not mean that the spectral sequence comes from some filtration \mathcal{F} , but only remembers the fact that it is the direct limit of the spectral sequences induced by the filtrations \mathcal{F}_i — in fact $E^r(\mathcal{F})$ is a spectral sequence of a filtration because a direct limit of filtered complexes is a filtered complex; however, the limit complex defining $E^r(\mathcal{F})$ is too abstract to be useful. This notation will be useful in the next section, when we will introduce another spectral sequence.

We now rewrite the differential ∂_0 in a way which highlights the roles played by the orbits h and h' ; this will be used extensively in the following subsections. By factoring out the terms h' and h , we can write the differentials ∂_V and ∂_N as

$$(9-6-3) \quad \partial_V \gamma = \partial_V^b \gamma, \quad \partial_V(h' \gamma) = h' \partial_V^b \gamma + \partial'_V(h' \gamma) \quad \text{and} \quad \partial_N \Gamma = \partial_N^b \Gamma + h \partial'_N \Gamma, \quad \partial_N(h \Gamma) = h \partial_N^b \Gamma,$$

where $\gamma \in \text{ECC}^b(V, \alpha_V)$, $\Gamma \in \text{ECC}^b(N, \alpha)$, ∂_V^b and ∂_N^b are the differentials for the chain complexes $\text{ECC}^b(V, \alpha_V)$ and $\text{ECC}^b(N, \alpha)$, and the terms $\partial'_V(h' \gamma)$ and $\partial'_N \Gamma$ do not contain h' .

9.7 The map σ_*

In this subsection we define an explicit map

$$\sigma_* : \text{ECH}(N, \partial N, \alpha) \rightarrow \text{ECH}(M)$$

and in the next one we will prove that it is an isomorphism. It will be easy to see that σ_* preserves the decomposition by (relative) homology classes; namely, if $\varpi : H_1(N, \partial N) \rightarrow H_1(M)$ is the isomorphism described in the introduction, σ_* maps $\text{ECH}(N, \partial N, A)$ to $\text{ECH}(M, \varpi(A))$ for every $A \in H_1(N, \partial N)$.

We introduce the following notation, which will be used in this and in the following sections. Given a set of Reeb orbits $e_1, \dots, e_n, h_1, \dots, h_m$, where e_1, \dots, e_n are elliptic and h_1, \dots, h_m are hyperbolic, we define

$$\mathcal{R}[e_1, \dots, e_n, h_1, \dots, h_m] := \mathbb{F}[e_1, \dots, e_n, h_1, \dots, h_m]/(h_1^2, \dots, h_m^2);$$

ie in $\mathcal{R}[e_1, \dots, e_n, h_1, \dots, h_m]$ the elliptic orbits are free variables and the hyperbolic orbits are nilpotent variables of order two. Whenever we use the notation $\mathcal{R}[e_1, \dots, e_n, h_1, \dots, h_m]$ in this paper, we will assume $\{e_1, \dots, e_n\} \subseteq \{e, e'\}$ and $\{h_1, \dots, h_m\} \subseteq \{h, h'\}$.

Define $\text{ECC}^{\natural}(N, \alpha)$ as $\mathcal{R}[h'] \otimes \text{ECC}^b(N, \alpha)$ with differential

$$\partial^{\natural}(\gamma \otimes \Gamma) = \gamma \otimes \partial^b \Gamma + \gamma/h' \otimes (1 + e)\Gamma.$$

Lemma 9.7.1 $\text{ECH}^{\natural}(N, \alpha) \simeq \text{ECH}(N, \partial N, \alpha).$

Proof $\text{ECC}^{\natural}(N, \alpha)$ can be identified with the cone of the multiplication map $\cdot(1 + e)$ on $\text{ECC}^b(N, \alpha)$. Hence there is an exact triangle

$$(9-7-1) \quad \begin{array}{ccc} \text{ECH}^b(N, \alpha) & \xrightarrow{\cdot(1+e)} & \text{ECH}^b(N, \alpha) \\ & \searrow & \swarrow \\ & \text{ECH}^{\natural}(N, \alpha) & \end{array}$$

The map $\cdot(1 + e)$ is injective on homology since Γ and $e\Gamma$ belong to different singular homology classes for all $\Gamma \in \text{ECC}^b(N, \alpha)$. Then the exact triangle implies that

$$\text{ECH}^{\natural}(N, \alpha) \simeq \frac{\text{ECH}^b(N, \alpha)}{(1 + e) \text{ECH}^b(N, \alpha)} \simeq \text{ECH}(N, \partial N, \alpha). \quad \square$$

We denote by $\text{ECC}^{\natural, L}_{\leq k}(N, \alpha)$ the subcomplex of $\text{ECC}^{\natural}(N, \alpha)$ generated by orbit sets $\gamma \otimes \Gamma$ which have linking number less than or equal to k with K and action less than L . We fix an increasing sequence $L'_k \rightarrow +\infty$ and let $c = \sup_k \mathcal{A}_{\alpha'_k}(e')$. Then, for every k , we choose i_k so that $L_{i_k} \geq kL'_k + ck^2$.

In the following, we will rename $L_{i_k} = L_k$, $\alpha'_{i_k} = \alpha'_k$ and $\mathcal{F}_{i_k} = \mathcal{F}_k$. Also, the composition $\widehat{\Phi}_{i_{k+1}-1} \circ \dots \circ \widehat{\Phi}_{i_k}$ will be renamed as

$$\widehat{\Phi}_k : \text{ECC}^{L_k}(M, \alpha'_k) \rightarrow \text{ECC}^{L_{k+1}}(M, \alpha'_{k+1}).$$

For any integer k , we define

$$\sigma_k : \text{ECC}_{\leq k}^{\natural, L'_k}(N, \alpha) \rightarrow \text{ECC}^{L_k}(M, \alpha'_k), \quad \gamma \otimes \Gamma \mapsto \sum_{i=0}^{\infty} (e')^i \gamma \otimes (\partial'_N)^i \Gamma,$$

where ∂'_N is defined by (9-6-3) and $\gamma = 1$ or h' .

These maps are well defined because the map ∂'_N is nilpotent. In fact, ∂'_N decreases the linking number with the binding, so $(\partial'_N)^{k+1} = 0$ on $\text{ECC}_{\leq k}^{\flat}(N, \alpha)$.

Remark 9.7.2 This and the analogous construction in Section 9.9 are the only places where we use the hypothesis that the Reeb flow is transverse to a fixed Seifert surface for K . In fact, while we could deduce the nilpotency of ∂'_N from an action argument, by choosing to work with the action we would lose the estimate on the nilpotency order of ∂'_N and, consequently, on the action of $\sigma_k(\gamma \otimes \Gamma)$. However, in view of the heuristic argument described in Section 9.1, we suspect that this hypothesis is actually not necessary.

Lemma 9.7.3 *The maps σ_k are chain maps and form a directed system, ie the following diagram commutes:*

$$(9-7-2) \quad \begin{array}{ccc} \text{ECC}_{\leq k}^{\natural, L'_k}(N, \alpha) & \xrightarrow{\sigma_k} & \text{ECC}^{L_k}(M, \alpha'_k) \\ \downarrow \iota_k & & \downarrow \widehat{\Phi}_k \\ \text{ECC}_{\leq k+1}^{\natural, L'_{k+1}}(N, \alpha) & \xrightarrow{\sigma_{k+1}} & \text{ECC}^{L_{k+1}}(M, \alpha'_{k+1}) \end{array}$$

Here ι_k is the inclusion.

Proof (1) We first show that σ_k is a chain map. Since σ_k takes values in the lowest level for the filtration \mathcal{F}_k (recall $\gamma = 1$ or h'), we have $\partial(\sigma_k(\Gamma)) = \partial_0(\sigma_k(\Gamma))$, where ∂_0 is given by (9-5-1). Using the decomposition of ∂_N in (9-6-3) and $\partial_V((e')^i \gamma) = (e')^i \gamma / h'$ for $\gamma = 1, h'$, we obtain

$$\begin{aligned} \partial_0(\sigma_k(\gamma \otimes \Gamma)) &= \partial_0 \left(\sum_{i=0}^{\infty} (e')^i \gamma \otimes (\partial'_N)^i \Gamma \right) \\ &= \sum_{i=0}^{\infty} (e')^i \gamma / h' \otimes (\partial'_N)^i \Gamma + \sum_{i=0}^{\infty} (e')^i \gamma \otimes (\partial_N^{\flat} (\partial'_N)^i \Gamma + h (\partial'_N)^{i+1} \Gamma) \\ &\quad + \sum_{i=1}^{\infty} (e')^{i-1} \gamma \otimes h (\partial'_N)^i \Gamma + \sum_{i=0}^{\infty} (e')^i \gamma / h' \otimes e (\partial'_N)^i \Gamma. \end{aligned}$$

Rearranging the sum and using the fact that ∂'_N commutes with ∂_N^b and with the multiplication by $1 + e$ gives

$$\partial_0(\sigma_k(\gamma \otimes \Gamma)) = \sum_{i=0}^{\infty} ((e')^i \gamma \otimes (\partial'_N)^i \partial_N^b \Gamma + (e')^i \gamma / h' \otimes (\partial'_N)^i ((1 + e)\Gamma)).$$

Hence $\partial(\sigma_k(\gamma \otimes \Gamma)) = \partial_0(\sigma_k(\gamma \otimes \Gamma)) = \sigma_k(\partial^{\natural}(\gamma \otimes \Gamma))$.

(2) Diagram (9-7-2) commutes because we have shown in Lemma 9.6.2 that the continuation maps are induced by the identity at the chain level on the lowest filtration level. □

Taking homology first and then direct limits in diagram (9-7-2), we obtain a map

$$\sigma_* : \text{ECH}(N, \partial N, \alpha) \simeq \text{ECH}^{\natural}(N, \alpha) \rightarrow \text{ECH}(M).$$

The maps σ_k also induce maps

$$\sigma^0 : \text{ECC}^{\natural}(N, \alpha) \rightarrow E^0(\mathcal{F}), \quad \gamma \otimes \Gamma \mapsto \sum_{i=0}^{\infty} (e')^i \gamma \otimes (\partial'_N)^i \Gamma,$$

and

$$\sigma^r : \text{ECH}(N, \partial N) \simeq \text{ECH}^{\natural}(N, \alpha) \rightarrow E^r(\mathcal{F}), \quad r > 0.$$

9.8 Computation of $E^1(\mathcal{F})$

In this subsection we compute the term $E^1(\mathcal{F})$ of the spectral sequence that converges to $\text{ECH}(M)$ and prove the first half of Theorem 1.1.1.

Recall from Lemma 9.6.3 that $E^0(\mathcal{F}) \simeq \text{ECC}(V, \alpha) \otimes \text{ECC}(N, \alpha)$ as a vector space and the differential ∂_0 is given by (9-5-1) and (9-6-3). If we write

$$C_{k,k'} = (h')^{k'} \text{ECC}^b(V, \alpha) \otimes h^k \text{ECC}^b(N, \alpha),$$

then

$$E^0(\mathcal{F}) \simeq \text{ECC}(V, \alpha) \otimes \text{ECC}(N, \alpha) = C_{0,0} \oplus C_{0,1} \oplus C_{1,0} \oplus C_{1,1}.$$

We can organize all components of the differential ∂_0 besides $\partial_V^b \otimes 1$ and $1 \otimes \partial_N^b$ in the diagram

$$(9-8-1) \quad \begin{array}{ccc} C_{0,1} & \xrightarrow{1 \otimes h \partial'_N + \cdot / e' \otimes h} & C_{1,1} \\ \partial'_V \otimes 1 + \cdot / h' \otimes e \downarrow & & \downarrow \partial'_V \otimes 1 + \cdot / h' \otimes e \\ C_{0,0} & \xrightarrow{1 \otimes h \partial'_N + \cdot / e' \otimes h} & C_{1,0} \end{array}$$

9.8.1 The filtration \mathcal{G} We introduce a filtration \mathcal{G} of length 3 on

$$(E^0(\mathcal{F}), \partial_0) = (\text{ECC}(V, \alpha) \otimes \text{ECC}(N, \alpha), \partial_0),$$

which is defined as

$$\mathcal{G}^0 = C_{1,0}, \quad \mathcal{G}^1 = C_{0,0} \oplus C_{1,1}, \quad \mathcal{G}^2 = C_{0,1}.$$

This filtration induces a spectral sequence $E^r(\mathcal{G})$ which converges to $E^1(\mathcal{F})$. The groups $E^r(\mathcal{G})$ have two gradings: one inherited from the grading on $E^0(\mathcal{F})$ (which, in turn, is induced by the filtrations \mathcal{F}_i) and one induced by the filtration \mathcal{G} . We will denote the homogeneous components of $E^r(\mathcal{G})$ by $E_{pq}^r(\mathcal{G})$, where p is the degree inherited from $E^0(\mathcal{F})$ and q is the degree induced by \mathcal{G} . We also write $E_p^r(\mathcal{G})$, in which case p is the degree inherited from $E^0(\mathcal{F})$.

9.8.2 Determination of $(E^1(\mathcal{G}), \partial_{01})$ The graded complex associated to \mathcal{G} is

$$(E^0(\mathcal{G}), \partial_{00}) \simeq (\mathcal{R}[h', h] \otimes \text{ECC}^b(V, \alpha) \otimes \text{ECC}^b(N, \alpha), 1 \otimes \partial_V^b \otimes 1 + 1 \otimes 1 \otimes \partial_N^b).$$

Then $(E^0(\mathcal{G}), \partial_{00})$ is a product complex and its homology can be computed by the Künneth formula:

$$E^1(\mathcal{G}) = \mathcal{R}[h', h] \otimes \text{ECH}^b(V, \alpha) \otimes \text{ECH}^b(N, \alpha).$$

Taking into account the grading inherited from $E^0(\mathcal{F})$ and the computation of $\text{ECH}^b(V, \alpha)$ from Theorem 8.1.2(4), we obtain

$$E_p^1(\mathcal{G}) \simeq \begin{cases} \mathcal{R}[e', h', h] \otimes \text{ECH}^b(N, \alpha) & \text{when } p = 0, \\ 0 & \text{when } p > 0. \end{cases}$$

Then $E_p^1(\mathcal{F}) = 0$ for $p > 0$ and standard properties of spectral sequences immediately imply the following lemma:

Lemma 9.8.1 *There is an isomorphism $E_0^1(\mathcal{F}) \simeq \text{ECH}(M)$ which is induced by the direct limit of the inclusion maps $E_0^0(\mathcal{F}_i) \hookrightarrow \text{ECC}^{L_i}(M, \alpha'_i)$.*

The differential ∂_{01} on $E^1(\mathcal{G})$ is induced by the components of ∂_0 between consecutive filtration levels. By Proposition 8.4.5 and Lemma 8.4.8, the only J -holomorphic map in $\mathbb{R} \times V$ with an end at h' is a disk in the foliation \mathcal{Z}_1 , which has ECH index $I = 1$. Therefore $\partial_V^b(h'(e')^i) = (e')^i$. Then the differential ∂_{01} on $E_{0,\bullet}^1(\mathcal{G})$ is described by the commutative diagram

$$(9-8-2) \quad \begin{array}{ccc} h'\mathcal{R}[e'] \otimes \text{ECH}^b(N, \alpha) & \xrightarrow{1 \otimes h\partial'_N + \cdot/e' \otimes h} & h'\mathcal{R}[e'] \otimes h \text{ECH}^b(N, \alpha) \\ \cdot/h' \otimes (1+e) \downarrow & & \downarrow \cdot/h' \otimes (1+e) \\ \mathcal{R}[e'] \otimes \text{ECH}^b(N, \alpha) & \xrightarrow{1 \otimes h\partial'_N + \cdot/e' \otimes h} & \mathcal{R}[e'] \otimes h \text{ECH}^b(N, \alpha) \end{array}$$

9.8.3 Homological algebra lemma The following elementary lemma in homological algebra will be used in the proof of Theorem 9.8.3:

Lemma 9.8.2 *Let A be an abelian group and $f, g: A \rightarrow A$ commuting morphisms. Consider the chain complex*

$$\mathcal{C}_\bullet = (0 \rightarrow C_2 \xrightarrow{\partial_2} C_1 \xrightarrow{\partial_1} C_0 \rightarrow 0) = (0 \rightarrow A \xrightarrow{\begin{pmatrix} f \\ g \end{pmatrix}} A^2 \xrightarrow{(g, -f)} A \rightarrow 0).$$

If f has a right inverse $s: A \rightarrow A$ (ie $f \circ s = \text{id}$) such that $g \circ s = s \circ g$, then

$$H_2(\mathcal{C}_\bullet) \simeq \ker f \cap \ker g, \quad H_1(\mathcal{C}_\bullet) \simeq \ker f / g(\ker f), \quad H_0(\mathcal{C}_\bullet) = 0.$$

Proof $H_2(\mathcal{C}_\bullet) \simeq \ker f \cap \ker g$ is immediate and $H_0(\mathcal{C}_\bullet) = 0$ follows from the surjectivity of f .

Next consider $H_1(\mathcal{C}_\bullet)$. By definition, we have $\ker \partial_1 = \{(x, y) \in A^2 \mid g(x) = f(y)\}$ and $\text{Im}(\partial_2) = \{(f(z), g(z)) \in A^2 \mid z \in A\}$. If we define the map

$$\phi: A \rightarrow A^2, \quad x \mapsto (x, g \circ s(x)) = (f \circ s(x), g \circ s(x)),$$

then we can write $\text{Im}(\partial_2) = \text{Im}(\phi) \oplus g(\ker f)$ and $\ker(\partial_1) = \text{Im}(\phi) \oplus \ker f$. The details are left to the reader. Hence $H_1(\mathcal{C}_\bullet) \simeq \ker f / g(\ker f)$. □

9.8.4 Completion of proof of Theorem 1.1.1(1) We use a comparison theorem for spectral sequences (eg [Eisenbud 1995, Exercise A3.41]) to prove Theorem 9.8.3, establishing Theorem 1.1.1(1).

Theorem 9.8.3 *The map $\sigma_*: \text{ECH}(N, \partial N, \alpha) \rightarrow \text{ECH}(M)$ is an isomorphism.*

Proof Since σ_k takes values in the lowest level of the filtration \mathcal{F}_k , σ_* factors through the map

$$\sigma^1: \text{ECH}(N, \partial N, \alpha) \simeq \text{ECH}^{\natural}(N, \alpha) \rightarrow E_0^1(\mathcal{F}).$$

By Lemma 9.8.1, it suffices to show that σ^1 is an isomorphism.

Recall the filtration \mathcal{G} on $E^0(\mathcal{F})$ from Section 9.8.1. On $\text{ECC}^{\natural}(N, \alpha)$ we define an analogous filtration \mathcal{G}^{\natural} such that

$$\mathcal{G}^{\natural}(\gamma \otimes \Gamma) = \begin{cases} 2 & \text{if } \gamma = h', \\ 1 & \text{if } \gamma = \emptyset. \end{cases}$$

This filtration induces a spectral sequence $E^r(\mathcal{G}^{\natural})$ such that $E_q^1(\mathcal{G}^{\natural}) \simeq \text{ECH}^b(N, \alpha)$ for $q = 1, 2$ and d_1 is the multiplication by $1 + e$. This is simply a reformulation of exact triangle (9-7-1) in the language of spectral sequences. The map σ^0 is compatible with the filtrations \mathcal{G}^{\natural} and \mathcal{G} and induces a map

$$\bar{\sigma}: E^1(\mathcal{G}^{\natural}) \rightarrow E^1(\mathcal{G}).$$

We now compute the homology of $(E^1(\mathcal{G}), \partial_{01})$ using Lemma 9.8.2. We set

$$A = \mathcal{R}[e'] \otimes \text{ECH}^b(N, \alpha), \quad f = 1 \otimes \partial'_N + \cdot / e' \otimes 1 \quad \text{and} \quad g = 1 \otimes (1 + e),$$

where $fg = gf$ by diagram (9-8-2). Define the map

$$s: \mathcal{R}[e'] \otimes \text{ECH}^b(N, \alpha) \rightarrow \mathcal{R}[e'] \otimes \text{ECH}^b(N, \alpha), \quad (e')^k \otimes \Gamma \mapsto (e')^k \sum_{i=1}^{\infty} (e')^i \otimes (\partial'_N)^{i-1} \Gamma,$$

where Γ denotes an element of $\text{ECH}^b(N, \alpha)$ and not an orbit set as usual. Then s is well defined since ∂'_N is nilpotent. Moreover, $fs = \text{id}$ and $gs = sg$. Then $E_{00}^2(\mathcal{G}) = E_{02}^2(\mathcal{G}) = 0$ because the map g is injective. Next consider $E_{01}^2(\mathcal{G}) = \ker f / g(\ker f)$. An element of $\ker f$ has the form

$$(e')^n \otimes \Gamma_n + (e')^{n-1} \otimes \Gamma_{n-1} + \cdots + 1 \otimes \Gamma_0,$$

where $\Gamma_i \in \text{ECH}^b(N, \alpha)$ and $\Gamma_{i+1} = \partial'_N \Gamma_i$ for $i = 0, 1, \dots$. Hence the map

$$\bar{\sigma}: \text{ECH}^b(N, \alpha) \rightarrow \mathcal{R}[e'] \otimes \text{ECH}^b(N, \alpha), \quad \Gamma \mapsto \sum_{i=0}^{\infty} (e')^i \otimes (\partial'_N)^i \Gamma,$$

is an isomorphism with $\ker f$. The diagram

$$\begin{array}{ccc} \text{ECH}^b(N, \alpha) & \xrightarrow{\bar{\sigma}} & \ker f \\ \cdot(1+e) \downarrow & & \downarrow \cdot(1+e)=g \\ \text{ECH}^b(N, \alpha) & \xrightarrow{\bar{\sigma}} & \ker f \end{array}$$

commutes because $\partial'_N(e\Gamma) = e\partial'_N(\Gamma)$ for all $\Gamma \in \text{ECH}^b(N, \alpha)$ by the trapping lemma. Hence $\bar{\sigma}$ induces an isomorphism

$$E^2(\mathcal{G}^{\natural}) \simeq \text{ECH}^b(N, \alpha)/(\Gamma + e\Gamma) \xrightarrow{\sim} E^2(\mathcal{G}) \simeq \ker f/g(\ker f).$$

By the comparison theorem for spectral sequences, σ^1 is an isomorphism. □

9.9 The U -map

In this subsection we prove that σ_* intertwines the map U on $\text{ECH}(M)$ with the map induced by ∂'_N on $\text{ECH}(N, \partial N, \alpha)$. This will allow us to deduce Theorem 1.1.1(2) from algebraic considerations. Let L_k and L'_k be as in Section 9.7.

We define the map

$$U^{\natural}: \text{ECC}^{\natural}(N, \alpha) \rightarrow \text{ECC}^{\natural}(N, \alpha), \quad \gamma \otimes \Gamma \mapsto \gamma \otimes \partial'_N \Gamma.$$

Since $U^{\natural}(\text{ECC}_{\leq k}^{\natural, L'_k}(N, \alpha)) \subseteq \text{ECC}_{\leq k}^{\natural, L'_k}(N, \alpha)$, we can define

$$U_k^{\natural}: \text{ECC}_{\leq k}^{\natural, L'_k}(N, \alpha) \rightarrow \text{ECC}_{\leq k}^{\natural, L'_k}(N, \alpha)$$

as the restriction of U^{\natural} to $\text{ECC}_{\leq k}^{\natural, L'_k}(N, \alpha)$.

We also define the chain complex

$$\widehat{\text{ECC}}^{\natural}(N, \alpha) = \mathcal{R}[h'] \otimes \text{ECC}(N, \alpha)$$

with differential

$$\widehat{\partial}^{\natural}(\gamma \otimes \Gamma) = \gamma \otimes \partial_N \Gamma + \gamma/h' \otimes (1+e)\Gamma.$$

The following lemma is similar to Lemma 9.7.1 and its proof will be omitted:

Lemma 9.9.1 $\widehat{\text{ECH}}^{\natural}(N, \alpha) \simeq \widehat{\text{ECH}}(N, \partial N, \alpha).$

The decomposition of the differential ∂_N described in (9-6-3) implies the following lemma:

Lemma 9.9.2 $\widehat{\text{ECC}}^{\natural}(N, \alpha)$ is isomorphic to the cone of U^{\natural} . If $L'_k \rightarrow \infty$ is an increasing sequence and $\widehat{\text{ECC}}^{\natural, L'_k}_{\leq k}(N, \alpha)$ is the cone of U_k^{\natural} , then

$$\lim_{k \rightarrow \infty} \widehat{\text{ECC}}^{\natural, L'_k}_{\leq k}(N, \alpha) \simeq \widehat{\text{ECC}}^{\natural}(N, \alpha).$$

Let z be a generic point in the interior of $\mathbb{R} \times V$. We denote by U_k the U -map on $\text{ECC}^{L_k}(M, \alpha'_k)$ defined with respect to z .

Lemma 9.9.3 The map U_k preserves the filtration \mathcal{F}_k for each k . On the lowest filtration level, generated by orbit sets $\gamma \otimes \Gamma$ such that $\gamma \in \mathcal{R}[e', h']$, U_k is given by

$$(9-9-1) \quad U_k(\gamma \otimes \Gamma) = \gamma/e' \otimes \Gamma.$$

Proof Fix k . By Lemma 9.4.1, the map U_k preserves the filtration \mathcal{F}_k . Moreover, by Lemma 9.5.1 (see also Corollary 9.5.2), curves which contribute to U_k and do not decrease the filtration level do not cross $\mathbb{R} \times T_i$ (for $i = 1, 2$). This implies that $U_k(\gamma \otimes \Gamma) = U_k(\gamma) \otimes \Gamma$ when $\gamma \in \mathcal{R}[e', h']$, and $U_k(\gamma)$ counts index $I = 2$ curves in V passing through z . We will use the ECH index and the Fredholm index to constrain such curves.

Let u be an $I = 2$, J'_k -holomorphic map in $\mathbb{R} \times V$ with $\gamma_+ = (e')^{a_+}(h')^{b_+}$ at the positive end and $\gamma_- = (e')^{a_-}(h')^{b_-}$ at the negative end; of course $b_{\pm} \in \{0, 1\}$. If we denote by $D_{e'}$ and $D_{h'}$ the meridian disks of V with boundary on e' and h' , respectively, and by $Z \in H_2(V, \gamma_+, \gamma_-)$ the relative homology class determined by u , we have $Z = (\alpha_+ - \alpha_-)[D_{e'}] + (\beta_+ - \beta_-)[D_{h'}]$.

We compute $I(\gamma_+, \gamma_-, Z)$ using (2-3-2). On e' and h' we consider the trivialization τ induced by ∂V . The Conley–Zehnder indices are $\mu_{\tau}((e')^i) = 1$ for $i = 1, \dots, k$ and $\mu_{\tau}(h') = 0$ by Definition 4.3.1, because they are on a slight perturbation of a positive Morse–Bott torus. The relative Chern class is $c_1(\xi|_{[D_{e'}]}, \tau) = c_1(\xi|_{[D_{h'}]}, \tau) = 1$. Putting everything together,

$$I(\gamma_+, \gamma_-, Z) = 2(a_+ - a_-) + (b_+ - b_-).$$

Then $I(\gamma_+, \gamma_-, Z) = 2$ implies $e_+ - a_- = 1$ and $b_+ - b_- = 0$, because $b_+ - b_- \in \{-1, 0, 1\}$. We call $b = b_+ = b_-$.

Negative ends at e' cannot be contained in $\mathbb{R} \times V$ by the trapping lemma, Lemma 5.3.2. (While the trapping lemma was proved for orbits on a Morse–Bott torus, it still holds for e' which is a slight elliptic perturbation.) Therefore u consists of a cover of a trivial cylinder over e' of degree a_- , together with a J'_k -holomorphic map $u: F \rightarrow \mathbb{R} \times V$ with positive asymptotics to $e'(h')^b$ and negative asymptotics to $(h')^b$ and representing the relative homology class $[D_{e'}]$. Since $\text{ind}(u) = 2$, the index formula (2-2-1) implies that $\chi(F) = 1$. This leaves only two possibilities: either u consists of a Fredholm index 2 plane which is positively asymptotic to e' together with a trivial cylinder over h' , or it consists of a Fredholm index one cylinder from e' to h' together with a Fredholm index one plane which is positively asymptotic

to h' . The second configuration cannot pass through a generic point z and therefore has to be discarded. The problem of computing U_k in the lowest filtration level is thus reduced to the count of J'_k -holomorphic planes in $\mathbb{R} \times V$ asymptotic to e' and passing through a generic point.

If we degenerate the contact forms α'_k toward the Morse–Bott contact forms α_k and the almost complex structures J'_k toward the almost complex structures J_k , the J'_k -holomorphic curves described above converge to very nice J_k -holomorphic Morse–Bott buildings because the topology of the domain does not allow the creation of branched covers of trivial cylinders (with nonempty branch locus) connected to Morse trajectories. Then, by Theorem 4.4.3(4), the count of $I = 2$, J'_k -holomorphic planes on $\mathbb{R} \times V$ which are positively asymptotic to e' and pass through a generic point z is the same as the count of Morse–Bott buildings consisting of a J_k -holomorphic plane on $\mathbb{R} \times V$ which passes through a generic point z and is positively asymptotic to an orbit of ∂V , augmented by a Reeb trajectory from e' to that orbit.

By Lemma 8.4.8, the principal part of such a Morse–Bott building must be a leaf of the finite-energy foliation \mathcal{Z}_1 . Since there is a unique leaf through any point, this proves that $U_k(\gamma \otimes \Gamma) = \gamma/e' \otimes \Gamma$. \square

Corollary 9.9.4 *The following diagram commutes for each k :*

$$(9-9-2) \quad \begin{array}{ccc} \text{ECC}_{\leq k}^{\mathfrak{h}, L'_k}(N, \alpha) & \xrightarrow{\sigma_k} & \text{ECC}^{L_k}(M, \alpha'_k) \\ U_k^{\mathfrak{h}} \downarrow & & \downarrow U_k \\ \text{ECC}_{\leq k}^{\mathfrak{h}, L'_k}(N, \alpha) & \xrightarrow{\sigma_k} & \text{ECC}^{L_k}(M, \alpha'_k) \end{array}$$

Proof Since σ_k takes values in the lowest level of the filtration \mathcal{F}_k , we can use (9-9-1) to compute $U_k \circ \sigma_k$. Then, for $\gamma \otimes \Gamma \in \text{ECC}_{\leq k}^{\mathfrak{h}, L'_k}(N, \alpha)$, we have

$$\begin{aligned} U_k(\sigma_k(\gamma \otimes \Gamma)) &= U_k\left(\sum_{i=0}^{\infty} (e')^i \gamma \otimes (\partial'_N)^i \Gamma\right) = \sum_{i=1}^{\infty} (e')^{i-1} \gamma \otimes (\partial'_N)^i \Gamma, \\ \sigma_k(U_k^{\mathfrak{h}}(\gamma \otimes \Gamma)) &= \sigma_k(\gamma \otimes \partial'_N \Gamma) = \sum_{i=0}^{\infty} (e')^i \gamma \otimes (\partial'_N)^{i+1} \Gamma. \end{aligned}$$

Hence $U_k \circ \sigma_k = \sigma_k \circ U_k^{\mathfrak{h}}$. \square

Proof of Theorem 1.1(2) By Lemma 9.9.2, diagram (9-9-2), and the naturality property of mapping cones, there is a chain map

$$\widehat{\sigma}_k : \widehat{\text{ECH}}_{\leq k}^{\mathfrak{h}, L'_k}(N, \alpha) \rightarrow \widehat{\text{ECC}}^{L_k}(M, \alpha'_k)$$

for each k . Taking homology (with the help of Lemma 9.9.1) and direct limits over k , we obtain a map

$$\widehat{\sigma}_* : \widehat{\text{ECH}}(N, \partial N, \alpha) \simeq \widehat{\text{ECH}}^{\mathfrak{h}}(N, \alpha) \rightarrow \widehat{\text{ECH}}(M).$$

This map fits into the U -map exact sequences by properties of mapping cones:

$$\begin{array}{ccccccc}
 \dots & \xrightarrow{U^\natural} & \text{ECH}(N, \partial N) & \longrightarrow & \widehat{\text{ECH}}(N, \partial N) & \longrightarrow & \text{ECH}(N, \partial N) \xrightarrow{U^\natural} \dots \\
 \sigma_* \downarrow & & \sigma_* \downarrow & & \hat{\sigma}_* \downarrow & & \sigma_* \downarrow & & \sigma_* \downarrow \\
 \dots & \xrightarrow{U} & \text{ECH}(M) & \longrightarrow & \widehat{\text{ECH}}(M) & \longrightarrow & \text{ECH}(M) \xrightarrow{U} \dots
 \end{array}$$

The five lemma then implies that $\hat{\sigma}_*$ is an isomorphism. Moreover, $\hat{\sigma}_*$ preserves the decompositions of $\widehat{\text{ECH}}(N, \partial N, \alpha)$ and $\widehat{\text{ECH}}(M)$ according to (relative) homology classes. □

Remark 9.9.5 Embedded contact homology can be defined over the integers by choosing a coherent orientation system for the moduli spaces. For its definition or construction we refer to [Bourgeois and Mohnke 2004; Hutchings and Taubes 2009a, Section 9]. Different choices of coherent orientation systems yield isomorphic chain complexes.

All results of this article carry over with integer coefficients, and with the same proofs, if there is a coherent orientation system such that

- the holomorphic plane with positive asymptotics at h' and the holomorphic plane with positive asymptotics at e' and passing through a generic point count positively;
- the holomorphic cylinders from e' to h and from h' to e count positively; and
- the holomorphic cylinders from e' to h' and from h to e have opposite signs, so that they cancel each other in the differentials.

The first two items can be easily obtained by automorphisms of the complexes adjusting the signs of the generators e', h', e and h , and the third item follows from the identification of orientations of moduli spaces of Morse trajectories with orientations of the corresponding moduli spaces of holomorphic maps, as sketched in the first paragraph of the proof of [Bourgeois 2002, Lemma 7.6].

10 Applications to sutured ECH

In this section we apply Theorem 1.1.1 to sutured ECH.

10.1 Sutured ECH

In this subsection we briefly review sutured ECH, referring the reader to [Colin et al. 2011b] for more details.

A *sutured manifold* is a pair (M, Γ) , where M is a 3-manifold with boundary and corners, $\Gamma \subset \partial M$ is a possibly disconnected 1-manifold,¹⁵ $N(\Gamma)$ is an annular neighborhood of Γ , and ∂M admits the decomposition into two-dimensional strata

$$\partial M = R_+(\Gamma) \cup R_-(\Gamma) \cup N(\Gamma)$$

¹⁵In this section, Γ will denote a suture, not an orbit set.

as in [Colin et al. 2011b, Definition 2.7]. Note that our definition does not allow for “torus sutures” as in Gabai’s original definition [1983, Definition 2.6].

A *sutured contact form* $\bar{\alpha}$ on (M, Γ) ¹⁶ (see [Colin et al. 2011b, Definition 2.8]) is, roughly speaking, a contact form $\bar{\alpha}$ on M whose Reeb vector field $R_{\bar{\alpha}}$ is positively transverse to $R_+(\Gamma)$, negatively transverse to $R_-(\Gamma)$, and tangent to $N(\Gamma)$, and such that the trajectories of $R_{\bar{\alpha}}|_{N(\Gamma)}$ are arcs from $\partial R_-(\Gamma)$ to $\partial R_+(\Gamma)$. One can easily verify that (M, Γ) admits a sutured contact form if and only if it is *balanced*, ie $\chi(R_+(\Gamma)) = \chi(R_-(\Gamma))$. A sutured contact manifold $(M, \Gamma, \bar{\alpha})$ admits a *completion* $(M^*, \bar{\alpha}^*)$; see [Colin et al. 2011b, Section 2.4].

Let $(M, \Gamma, \bar{\alpha})$ be a sutured contact manifold. We now describe the *sutured ECH group* $\text{ECH}(M, \Gamma, \bar{\alpha}, J)$. Its chain group¹⁷ $\text{ECC}(M, \Gamma, \bar{\alpha}, J)$ is generated by orbit sets constructed from simple Reeb orbits in $\text{int}(M)$ and the differential counts ECH index one J -holomorphic maps in the symplectization of $(M^*, \bar{\alpha}^*)$ for an almost complex structure J which is adapted to the symplectization and satisfies properties (A₀)–(A₂) from [Colin et al. 2011b, Section 3.1]. Almost complex structures of this type are said to be *tailored to* $(M, \Gamma, \bar{\alpha})$.

Completions are not necessary in dimension three by the following lemma:

Lemma 10.1.1 *Let J be tailored to $(M, \Gamma, \bar{\alpha})$. Then all J -holomorphic curves in $(M^*, \bar{\alpha}^*)$ which are asymptotic to closed Reeb orbits in $\text{int}(M)$ are contained in $\mathbb{R} \times \text{int}(M)$.*

Proof This follows from the proofs of [Colin et al. 2011b, Lemma 5.6 and Corollary 5.7], and relies on the fact that $R_+(\Gamma)$ and $R_-(\Gamma)$ automatically admit Stein structures. □

We finish this review of sutured ECH by recalling a useful result from [Colin et al. 2011b] and sketching a simpler proof in dimension three.

Definition 10.1.2 [Colin et al. 2011b, Section 9] Let $(M, \Gamma, \bar{\alpha})$ be a sutured contact manifold. An *interval-fibered extension* is a contact embedding

$$(M, \Gamma, \bar{\alpha}) \hookrightarrow (M', \Gamma', \bar{\alpha}')$$

such that $M' - \text{int}(M) = W \times [0, 1]$, where

- W is a cobordism from Γ' to Γ , and
- $\bar{\alpha}'|_{W \times [0,1]} = c dt + \beta$ for a Liouville form β on W and $c > 0$.

Lemma 10.1.3 [Colin et al. 2011b, Theorem 9.1] *Let $(M, \Gamma, \bar{\alpha}) \hookrightarrow (M', \Gamma', \bar{\alpha}')$ be an interval-fibered extension. Then there is a canonical isomorphism of chain complexes between $\text{ECC}(M, \Gamma, \bar{\alpha})$ and $\text{ECC}(M', \Gamma', \bar{\alpha}')$.*

¹⁶We use $\bar{\alpha}$ to denote an unspecified sutured contact form because α is reserved, in Section 9, to the contact form on N . Such contact form will appear again later in this section.

¹⁷We will often write $\text{ECC}(M, \Gamma, \bar{\alpha})$ and $\text{ECH}(M, \Gamma, \bar{\alpha})$ for simplicity.

Proof All closed Reeb orbits in M' are contained in M because all Reeb trajectories in $M' - \text{int}(M)$ go from $R_-(\Gamma')$ to $R_+(\Gamma')$. Moreover, J -holomorphic curves in $\mathbb{R} \times M'$ between orbit sets in $\text{int}(M)$ are contained in $\mathbb{R} \times M$. In fact, if a J -holomorphic curve nontrivially intersects $\mathbb{R} \times (M' - M) = \mathbb{R} \times W \times [0, 1]$, then its projection to W is surjective by the positivity of intersections with the Reeb vector field. This implies that the curve touches $\mathbb{R} \times \partial M'$, which is impossible by Lemma 10.1.1. \square

10.2 Topological invariance of sutured ECH

In this subsection we pay off a debt from [Colin et al. 2011b], namely we sketch a proof that sutured ECH depends only on the sutured manifold and the contact structure. A more detailed proof can be found in [Kutluhan et al. 2022]. In view of [Colin et al. 2011b, Conjecture 1.5], we expect sutured ECH to be independent also of the contact structure.

Lemma 10.2.1 *Let $(M, \Gamma, \bar{\alpha})$ be a sutured contact manifold such that Γ is connected. Then, for every $L \gg 0$, we can embed $(M, \Gamma, \bar{\alpha})$ into a closed contact manifold $(\tilde{M}, \tilde{\alpha}^L)$ such that*

$$\text{ECH}^{L'}(M, \Gamma, \bar{\alpha}) \simeq \text{ECH}^{L'}(\tilde{M}, \tilde{\alpha}^L)$$

for every $L' \leq L$. Moreover, \tilde{M} , up to diffeomorphism, depends only on (M, Γ) and, if $\bar{\alpha}_0$ and $\bar{\alpha}_1$ define isotopic contact structures on (M, Γ) , then $\tilde{\alpha}_0^L$ and $\tilde{\alpha}_1^L$ define isotopic contact structures on \tilde{M} .

Proof Since (M, Γ) is balanced and Γ is connected, $R_+(\Gamma)$ and $R_-(\Gamma)$ have the same genus and are diffeomorphic. We identify $\partial R_+(\Gamma)$ and $\partial R_-(\Gamma)$ by a diffeomorphism $\partial h_0: \partial R_+(\Gamma) \xrightarrow{\sim} \partial R_-(\Gamma)$, which is defined by the Reeb flow on $N(\Gamma)$, and fix a diffeomorphism $h_0: R_+(\Gamma) \xrightarrow{\sim} R_-(\Gamma)$ which extends ∂h_0 . Let us write $\beta_+ = \bar{\alpha}|_{R_+(\Gamma)}$ and $\beta_- = \bar{\alpha}|_{R_-(\Gamma)}$. Then the contact form $\bar{\alpha}$, on a neighborhood $R_+(\Gamma) \times [1 - \epsilon, 1]$ or $R_-(\Gamma) \times [-1, -1 + \epsilon]$ of $R_\pm(\Gamma) = R_\pm(\Gamma) \times \{\pm 1\}$ with coordinates (x, t) , has the form $c dt + \beta_\pm$ for some $c > 0$ (see [Colin et al. 2011b, Definition 2.8]). Here $\epsilon > 0$ is small.

By Moser's theorem and Lemma 9.3.2, there is a diffeomorphism $h: R_+(\Gamma) \xrightarrow{\sim} R_-(\Gamma)$ isotopic to h_0 relative to ∂h_0 , such that $h^*\beta_- - \beta_+ = df$ for some function $f: R_+(\Gamma) \rightarrow \mathbb{R}$ which is constant near $\partial R_+(\Gamma)$.

Let us write $R = R_+(\Gamma)$. By repeating the proof of Lemma 9.3.3, we construct a contact form $f_t dt + \beta_t$ on $R \times [1, 2]$ such that $f_t > 0$, $f_t dt + \beta_t = c dt + \beta_+$ on $R \times [1, 1 + \epsilon]$, and $f_t dt + \beta_t = c dt + h^*\beta_-$ on $R \times [2 - \epsilon, 2]$. Pick a bump function $\varphi: [1, 2] \rightarrow [1, 2]$ and consider the contact forms $(f_t + C_L \varphi(t)) dt + \beta_t$ on $R \times [1, 2]$ for some large positive constant C_L to be determined later.

We obtain the manifold M' by gluing $R \times \{1\}$ to $R_+(\Gamma)$ by the identity and $R \times \{2\}$ to $R_-(\Gamma)$ by h . The contact forms $\bar{\alpha}$ on M and $(f_t + C_L \varphi(t)) dt + \beta_t$ on $R \times [1, 2]$ match near the gluing region, so they define a contact form on M' . Finally, we obtain \tilde{M} by gluing a solid torus V to M' along the boundary so that a meridian of the solid torus is identified with a Reeb orbit on $\partial M'$. The contact form on M' can be extended to a contact form $\tilde{\alpha}^L$ on \tilde{M} by taking the contact form on V as in Example 6.2.4.

By taking C_L sufficiently large, we ensure that Reeb trajectories from $R_+(\Gamma)$ to $R_-(\Gamma)$ and closed Reeb orbits in V have action larger than L ; for Reeb orbits in V this is a simpler application of the arguments in the proof of Lemma 7.2.3. Hence $\text{ECC}^{L'}(M, \Gamma, \bar{\alpha}) = \text{ECC}^{L'}(\tilde{M}, \tilde{\alpha}^L)$ as abelian groups if $L' \leq L$. Any tailored almost complex structure J on $\mathbb{R} \times M$ can be extended to an almost complex structure J on $\mathbb{R} \times \tilde{M}$ which is adapted to the symplectization of $\tilde{\alpha}^L$.

Next we claim that a J -holomorphic map $u: F \rightarrow \mathbb{R} \times \tilde{M}$ which is asymptotic to orbit sets in M has image in $\mathbb{R} \times M$. These orbit sets have trivial linking number with the core of V , so $\text{Im}(u) \subset \mathbb{R} \times M'$ by the blocking lemma. On the other hand, $\text{Im}(u) \cap (\mathbb{R} \times R \times [1, 2]) = \emptyset$: Observe that $R_{\pm}(\Gamma)$ can be lifted to a family v_s for $s \in \mathbb{R}$ of J -holomorphic maps in $\mathbb{R} \times M'$ which foliate $\mathbb{R} \times R_{\pm}(\Gamma)$. By the positivity of intersections, if u intersects some v_s , then it intersects all v_s . However $\text{Im}(u_{M'}) \cap R_{\pm}(\Gamma)$ is compact and u cannot intersect v_s for $s \gg 0$, a contradiction. Hence $\text{Im}(u) \subset \mathbb{R} \times M$.

The remaining claims in the statement are straightforward. □

Theorem 10.2.2 *Let $\bar{\alpha}_1$ and $\bar{\alpha}_2$ be sutured contact forms on a sutured three-manifold (M, Γ) and let J_1 and J_2 be almost complex structures on $\mathbb{R} \times M$ such that J_i is tailored to $(M, \Gamma, \bar{\alpha}_i)$ for $i = 1, 2$. If $\xi_1 = \ker \bar{\alpha}_1$ and $\xi_2 = \ker \bar{\alpha}_2$ are isotopic through contact structures adapted to the sutures, then*

$$\text{ECH}(M, \Gamma, \bar{\alpha}_1, J_1) \simeq \text{ECH}(M, \Gamma, \bar{\alpha}_2, J_2).$$

Moreover, this isomorphism preserves the decomposition of the sutured ECH groups as direct sums of subgroups indexed by homology classes in $H_1(M)$.

Proof We may assume that Γ is connected, since otherwise we can make Γ connected by gluing an interval-fibered extension, which does not change the sutured ECH groups by Lemma 10.1.3. We extend $(M, \Gamma, \bar{\alpha}_i)$ to $(\tilde{M}, \tilde{\alpha}_i^L)$ as in Lemma 10.2.1 and follow the proof of Proposition 7.2.1 step by step. The statement about the decomposition according to homology classes follows from the fact that the isomorphism is supported on holomorphic buildings contained in $\mathbb{R} \times M$ in the sense of Theorem 3.1.2(i). □

10.3 Applications

If M is a closed 3-manifold and $B \subset M$ is an embedded open 3-ball, we define the sutured manifold

$$M(1) = (M - B, \Gamma_0),$$

where Γ_0 is a connected simple closed curve in $\partial(M - B)$. If $K \subset M$ is a knot and $N(K)$ is an open tubular neighborhood of K , we define the sutured manifold

$$M(K) = (M - N(K), \Gamma_K),$$

where Γ_K consists of two disjoint copies of a meridian of K . When considering $M(1)$, we will assume that $K \setminus B$ is connected and goes from $R_-(\Gamma)$ to $R_+(\Gamma)$. If $\bar{\alpha}$ is a contact form on $M - B$ or $M - N(K)$ satisfying the conditions in [Colin et al. 2011b, Definition 2.8], then the sutured ECH groups $\text{ECH}(M(1), \bar{\alpha})$ and $\text{ECH}(M(K), \bar{\alpha})$ are defined.

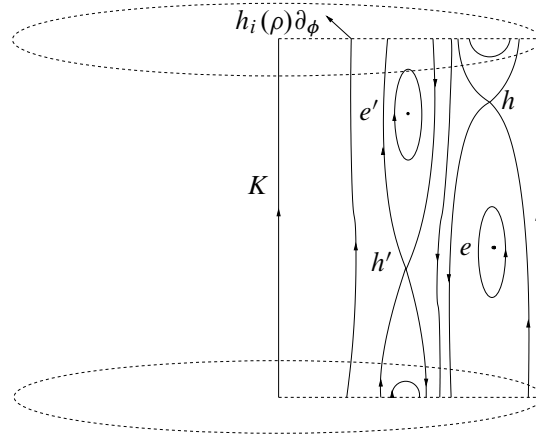

Figure 5: The Reeb vector field R'_i on $N_0(K) = (T^2 \times [1, 2]) \cup V$. The top and the bottom are identified.

Theorem 10.3.1 $\widehat{\text{ECH}}(M) \simeq \text{ECH}(M(1), \bar{\alpha})$.

This theorem concludes the proof of [Colin et al. 2011b, Theorem 1.6].

Proof Let ξ be a contact structure on M extending $\bar{\xi} = \ker \bar{\alpha}$ such that $K \subset M$ is a ξ -transverse knot. Recall the decomposition

$$M = N \cup (T^2 \times [1, 2]) \cup V$$

from previous sections, where we take $N_0(K) = (T^2 \times [1, 2]) \cup V$ to be a neighborhood of K .

There exists a sequence of contact forms α'_i for $i = 0, 1, \dots$ for ξ (up to isotopy) and associated Reeb vector fields R'_i , satisfying properties (1)–(8) of Section 9.2. Figure 5 depicts R'_i on $N_0(K) \simeq D^2(2) \times S^1$ with cylindrical coordinates (ρ, ϕ, θ) , where $D^2(\rho_0) = \{\rho \leq \rho_0\}$ and $V \simeq D^2(1) \times S^1$. The Reeb vector field R'_i is ∂_ϕ -invariant and of the form $R'_i = Y + h_i(\rho)\partial_\phi$, where Y is tangent to the slices $\{\phi = \text{const}\}$ as given in Figure 5 and $h_i(\rho) > 0$ for $\rho > 0$.

Choose almost complex structures J'_i adapted to α'_i as in Section 9.2 so that J'_i is ∂_ϕ -invariant on $N_0(K)$ and is close to the almost complex structure J_0 from Proposition 8.4.4 on V .

We describe a concave ball B in M whose complement is $M(1)$; see Figure 6. Let D be a meridian disk in V which bounds e' and is the projection to V of an $I = 2, J'_i$ -holomorphic plane u asymptotic to e' at the positive end. The plane u corresponds to a leaf of the finite-energy foliation \mathcal{Z}_0 of $\mathbb{R} \times V$ from Proposition 8.4.4. Let $N(e')$ be a neighborhood of e' whose boundary is tangent to R'_i . We then set $B = N(D) \cup N(e')$, where $N(D)$ is a small neighborhood of D , chosen so that ∂B decomposes into three parts:

- two disks $R_\pm(\Gamma_0)$ transverse to R'_i that are parallel copies of a small retract of D ; and
- an annulus $N(\Gamma_0) \subset \partial N(e')$ tangent to R_i .

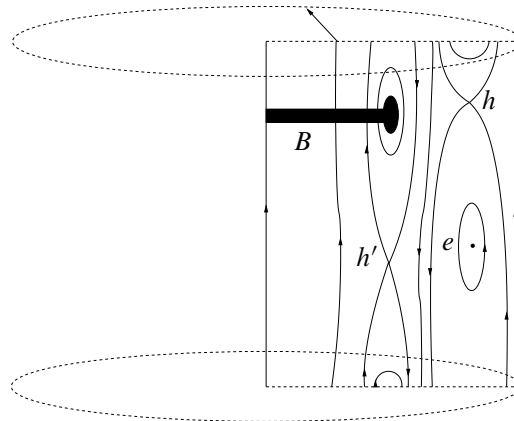

Figure 6: The concave ball B , obtained by rotating the shaded region about the vertical axis.

We assume that the $I = 1$, J'_i -holomorphic plane asymptotic to h' has image in $\mathbb{R} \times (V - B)$ and that $R_{\pm}(\Gamma_0)$ are also chosen to be restrictions of projections to M of $I = 2$, J'_i -holomorphic planes asymptotic to e' . The trajectories of R_i flow from one boundary component of $N(\Gamma_0)$ to the other.

The manifold $(M(1), \Gamma_0, \alpha'_i)$ is a sutured contact manifold and, by Theorem 10.2.2, $\text{ECH}(M(1), \Gamma_0, \alpha'_i)$ is isomorphic to $\text{ECH}(M(1), \Gamma_0, \bar{\alpha})$. By construction, the orbit e' does not belong to $M(1)$ and all the orbits in V are now chords from $\partial M(1)$ to $\partial M(1)$. The Reeb orbits of R'_i that are contained in $M(1)$ are

- (1) all Reeb orbits in N ;
- (2) e, h and h' ; and
- (3) orbits longer than L_i in the no man's land.

By taking direct limits as in Section 9.6, we can discard orbits in the no man's land. The use of direct limits in this context is justified by Theorem 10.2.2.

By our choice of J'_i , if u is a holomorphic curve in $\mathbb{R} \times M$ between orbit sets constructed from orbits of type (1) and (2) in $M(1)$, then $\text{Im}(u) \subset \mathbb{R} \times M(1)$. (The orbits of type (1) and (2) have the lowest \mathcal{F}_i -filtration level and we can use the blocking and trapping lemmas.) In particular, there are exactly two $I = 1$ curves that limit to h' at the positive end, as it is in $\mathbb{R} \times N_0(K)$: one plane from h' to \emptyset and one cylinder from h' to e . Therefore we obtain an identification

$$\lim_{i \rightarrow \infty} (\text{ECC}^{L_i}(M(1), \Gamma_0, \alpha'_i), \partial) \simeq (\widehat{\text{ECC}}^{\natural}(N, \alpha), \widehat{\partial}^{\natural}),$$

which, in view of Lemma 9.9.1 and Theorem 1.1.1(2), implies the theorem. □

If the contact form $\bar{\alpha}$ is chosen carefully, a null-homologous knot $K \subset M$ induces a filtration on the chain complex $\text{ECC}(M(1), \bar{\alpha})$ and the associated graded group is $\text{ECC}(M(K), \bar{\alpha})$. This construction was described in [Colin et al. 2011b, Section 7.2]. If $N = M - N_0(K)$ as above, there is a filtration \mathcal{E} on $\widehat{\text{ECC}}(N, \partial N, \alpha)$ defined as follows: Let \mathcal{P} be the set of simple Reeb orbits in $\text{int}(N)$. The generators of

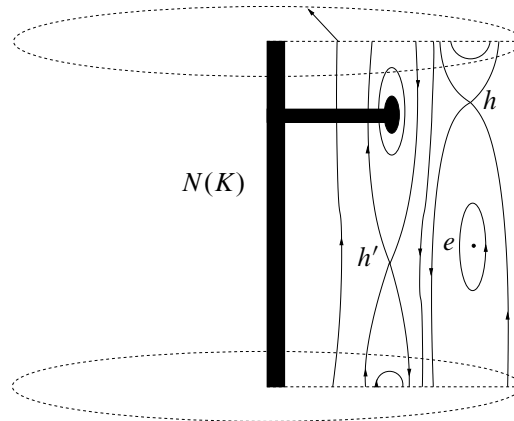

Figure 7: Construction of the concave neighborhood $(N(K), \Gamma_K)$, obtained by rotating the shaded region about the vertical axis

$\widehat{\text{ECC}}(N, \partial N, \alpha)$ are equivalence classes of orbit sets Γ constructed from $\mathcal{P} \cup \{h, e\}$, up to the equivalence relation $\Gamma \sim e\Gamma$. To the equivalence class of Γ we can uniquely associate an orbit set Γ' constructed from $\mathcal{P} \cup \{h\}$. Then we define $\mathcal{E}(\Gamma)$ as the algebraic intersection of Γ' with a Seifert surface of K . The differential of $\widehat{\text{ECC}}(N, \partial N, \alpha)$ preserves \mathcal{E} by the trapping lemma and it is easy to identify the graded group of this filtration with $\text{ECC}^\#(N, \alpha)$.

Theorem 10.3.2 *If $K \subset M$ is a null-homologous knot, then there is a contact form $\bar{\alpha}$ on M for which the isomorphism in Theorem 10.3.1 preserves the filtrations and induces an isomorphism*

$$\text{ECH}(M(K), \bar{\alpha}) \simeq \text{ECH}^\#(N, \alpha).$$

Proof Let $K \subset M$ be a null-homologous knot and Σ a genus-minimizing Seifert surface for K . Following [Colin and Honda 2005], we construct a family of contact forms α'_i on M as in the proof of Theorem 10.3.1 on $N_0(K)$, with the additional property that the Reeb vector fields R'_i are positively transverse to $\text{int}(\Sigma)$. The construction is done in two steps: first on N by a direct application of [Colin and Honda 2005], where we use Σ as the first decomposing surface of a taut sutured hierarchy of N , and then on $N_0(K)$, where we extend the form by the explicit model already described in Section 9.3.2.

We obtain a concave neighborhood $(N(K), \Gamma_K)$ of K by taking $N(K) = B \cup N_\epsilon(K)$, where $N_\epsilon(K)$ is a very small neighborhood of K whose boundary is tangent to R'_i , as in Figure 7, and B is the ball constructed in the proof of Theorem 10.3.1.

The suture Γ_K corresponds to the core curves of the two annuli in $\partial N(K)$ tangent to R'_i . At this point, $(M - N(K), \Gamma_K)$ is not yet a convex sutured manifold, because $\partial N(K)$ is not convex for the dividing set given by the two curves of Γ_K . In fact, on the component A of $\partial N(K)$ coming from $N_\epsilon(K)$, $\ker \alpha'_i|_A$ is negatively transverse to the core of A (oriented as the boundary of $R_+(\Gamma_K)$). To correct this, we glue a collar of the form $(A \times [a, b], dt + f(y) dx)$, $\partial f/\partial y < 0$, to $(M - N(K), \alpha'_i)$ along $A = A \times \{a\}$, where

$A \times [a, b] = [0, 1] \times S^1 \times [a, b]$ has coordinates (t, x, y) . Then the Reeb vector field remains ∂_t while the contact plane rotates until $\ker \alpha'_i|_{A \times \{b\}}$ is positively transverse to the core of A .

The positive transversality of the Reeb vector fields with the Seifert surface Σ ensures that the isomorphism of Theorem 10.3.1 preserves the filtrations given by the linking number with K .

Passing from $M(1)$ to $M(K)$ has the effect of killing the “meridian” holomorphic disk from h' which passes through $\mathbb{R} \times K$. After passing to direct limits, we obtain the desired isomorphism. \square

Appendix Morse–Bott gluing

by Vincent Colin, Paolo Ghiggini, Ko Honda and Yuan Yao

The goal of this appendix is to prove Parts (2) and (3) of Theorem 4.4.3. The proof of Part (4) is similar and will be omitted. The proof involves working out Morse–Bott gluing in a special case, which easily generalizes to one-level cascades in ECH. Yao [2022b; 2022a] will prove the general ECH Morse–Bott gluing theorem in the presence of Morse–Bott tori and multiple-level cascades. There are slight differences in packaging, but our strategy and the one from [Yao 2022b; 2022a] for 1-level cascades are essentially equivalent.

For simplicity we assume there is only one Morse–Bott torus $T_{\mathcal{N}}$ and that it is a negative Morse–Bott torus. It is generally acknowledged that the proof of Morse–Bott gluing in [Bourgeois 2002] is incomplete, but instead of fixing this, we carry out a different pregluing with a smaller error term. At first we will use a stable Hamiltonian structure whose hyperplane distribution is integrable near the Morse–Bott torus to simplify the gluing estimates in various ways. *In Section A.9 we will explain how to derive a similar statement for contact structures from Theorem A.2.1.*

A.1 Stable Hamiltonian structures, almost complex structures and moduli spaces

Let $[-1, 1] \times T^2 = [-1, 1] \times (\mathbb{R}^2/\mathbb{Z}^2)$ be a neighborhood of the negative Morse–Bott torus $T_{\mathcal{N}}$ with coordinates $(y, (\theta, t))$ such that $T_{\mathcal{N}} = \{0\} \times T^2$, and let \mathcal{N} be the Morse–Bott family of simple orbits of the form $\{y = 0, \theta = \text{const}\}$. Also let $A_{y_0} = [-y_0, y_0] \times \mathbb{R}/\mathbb{Z}$ be an annulus with coordinates (y, θ) .

Morse–Bott perturbation of the stable Hamiltonian vector field The construction will depend on parameters c, a, b_0, b and ϵ which will be made more specific during the course of this appendix and when we make specific choices they will be indicated by (\dagger_0) – (\dagger_3) . The parameters c, a and b_0 (chosen in this order) will describe the data of the problem and will be chosen once and for all at the beginning to satisfy

$$0 < 4b_0 < a < c < 1.$$

The constant c depends on the action level, a depends on the Morse–Bott moduli spaces we want to glue—morally speaking it determines the region where the first nonconstant term in the Fourier expansion of the negative end is not dominated by the higher-order terms; see (\dagger_1) —and b_0 is arbitrary, as long as it

is sufficiently smaller than a . The perturbation of the Morse–Bott Reeb vector field and pregluing will depend on the parameters $b \in (0, \frac{1}{2}b_0)$ and $\epsilon > 0$ (chosen in this order). The parameter b will determine the support of the perturbation and the parameter ϵ the size. Then, by the usual contraction mapping argument, we will prove that, for every b sufficiently small and every ϵ sufficiently small compared to b , the preglued curve can be deformed to a holomorphic curve.

On $[-c, c] \times T^2$ consider the stable Hamiltonian structure consisting of the 1-form dt and the 2-form $\omega_H = dH \wedge dt + dy \wedge d\theta$, where $H: A_c \rightarrow \mathbb{R}$ is a function of (y, θ) (and is independent of t). The stable Hamiltonian vector field R_H is then

$$(A-1-1) \quad R_H = \frac{\partial}{\partial t} + X_H, \quad \text{where } i_{X_H} dy \wedge d\theta = dH.$$

Let J_H be the adapted almost complex structure on $\mathbb{R} \times [-c, c] \times T^2$ which sends $\partial/\partial s \mapsto R_H$, $R_H \mapsto -\partial/\partial s$, $\partial/\partial y \mapsto \partial/\partial \theta$ and $\partial/\partial \theta \mapsto -\partial/\partial y$, where s is the \mathbb{R} -coordinate.

We specialize the smooth function H to

$$(A-1-2) \quad f(y, \theta) = \frac{1}{2}y^2 \quad \text{or} \quad f_\epsilon(y, \theta) = \frac{1}{2}y^2 + \epsilon\phi(y)\bar{g}_N(\theta),$$

where $\epsilon > 0$ is small, the domain of $\bar{g}_N(\theta)$ is S^1 viewed as the interval $[-\frac{1}{2}, \frac{1}{2}]$ with the endpoints identified, and the following hold:

- (P2) $\bar{g}_N: \mathbb{R}/\mathbb{Z} \rightarrow \mathbb{R}$ is a perfect Morse function with maximum at $\frac{1}{4}$ and minimum at $-\frac{1}{4}$. More specifically, we assume that $\bar{g}'_N(\theta) = 0$ on $\theta = \pm\frac{1}{4}$, is linear with positive slope on $[-\frac{1}{4}, -\frac{1}{5}]$, is nondecreasing on $[-\frac{1}{5}, -\frac{1}{6}]$, and is equal to 1 on $[-\frac{1}{6}, \frac{1}{6}]$; and $\bar{g}_N(\theta)$ is an odd function about $\theta = 0$.
- (P3') $\phi: [-c, c] \rightarrow [0, 1]$ is an even function which has support on $[-2b_0, 2b_0]$ and is equal to 1 on $[-b_0, b_0]$.

Here (P2) is exactly the same as (P2) from Section 4.1 and (P3') is a tweaking of (P3). We observe that $f_\epsilon \rightarrow f$ in C^∞ as $\epsilon \rightarrow 0$.

The torus T_N is a negative Morse–Bott torus with respect to R_f . After perturbing to R_{f_ϵ} , the Morse–Bott family of stable Hamiltonian orbits becomes a pair e and h of stable Hamiltonian orbits over $(0, -\frac{1}{4})$ and $(0, \frac{1}{4})$ in A_c . See Figure 8.

The Morse–Bott perturbation is performed below a fixed action L , which is later sent to infinity by a direct limit process. The action of a stable Hamiltonian orbit in $[-c, c] \times T^2$ depends on how many times it intersects an annulus $A_c \times \{t\}$ and therefore, instead of working below an action level L , we work below an intersection number N .

- (†₀) The constant c is chosen so that $0 < c < 1$ and all closed orbits of R_f in $A_c \times S^1$ that intersect $A_c \times \{t\}$ at most N times are covers of orbits in T_N . The constant $\epsilon > 0$ will always be small enough that all closed orbits of R_{f_ϵ} in $A_c \times S^1$ that intersect $A_c \times \{t\}$ at most N times are covers of e and h .

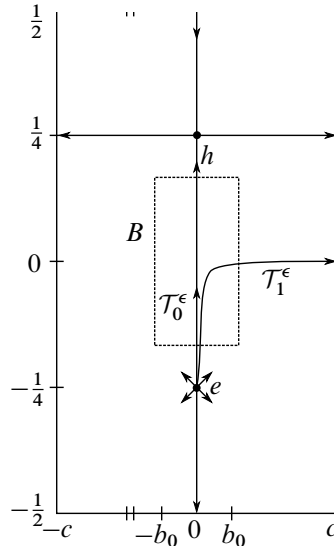

Figure 8: The annulus $A_c = [-c, c] \times \mathbb{R}/\mathbb{Z}$ with some gradient trajectories of f_ϵ . The top and the bottom are identified. The dotted rectangle is the boundary of $B = [-b_0, b_0] \times [-\frac{1}{6}, \frac{1}{6}]$, on which $\phi(y) = 1$ and $\bar{g}'_{\mathcal{N}}(\theta) = 1$.

The next lemma follows from the explicit constructions in Section A.9 and Claim A.9.3.

Lemma A.1.1 *There exist stable Hamiltonian structures (α, ω) and $(\alpha, \omega_\epsilon)$ on M and almost complex structures J_f and J_{f_ϵ} on $\mathbb{R} \times M$ such that:*

- (1) *On $[-a, a] \times T^2$, $(\alpha, \omega) = (dt, \omega_f)$ and $(\alpha, \omega_\epsilon) = (dt, \omega_{f_\epsilon})$.*
- (2) *On $M - ([-a, a] \times T^2)$, $\omega = \omega_\epsilon$ is a multiple of $d\alpha$ by a positive function (and therefore α is a contact form).*
- (3) *On $M - ([-c, c] \times T^2)$, $\omega = \omega_\epsilon = d\alpha$.*
- (4) *J_f and J_{f_ϵ} are adapted to (α, ω_f) and $(\alpha, \omega_{f_\epsilon})$, respectively, and $J_f = J_{f_\epsilon}$ outside of $\mathbb{R} \times [-a, a] \times T^2$.*

Simplification A.1.2 From now on we will consider only the case $N = 1$ because it contains already all the relevant ideas.

Moduli spaces Let

$$\mathcal{M}^{\text{MB}} := \mathcal{M}_{J_f}^{\text{MB}} := \mathcal{M}_{J_f}^{I=\text{ind}=1}(\boldsymbol{\gamma}; \mathcal{N})$$

be the moduli space of (finite-energy) J_f -holomorphic maps $u_+ : (\dot{F}, j) \rightarrow \mathbb{R} \times M$ modulo domain automorphisms, where

- (C0) (\dot{F}, j) is a closed Riemann surface with a finite number of punctures removed and we are ranging over all complex structures j with a fixed topological type \dot{F} ;
- (C1) u_+ limits to the orbit set $\boldsymbol{\gamma}$ at the positive end, where $\boldsymbol{\gamma}$ does not involve any orbits of the Morse–Bott family \mathcal{N} ;

- (C2) u_+ limits to some orbit in the Morse–Bott family \mathcal{N} at the negative end; and
- (C3) u_+ has “unconstrained” Fredholm and ECH index 1 (the negative end is unconstrained); see Section 8.4.1 for more details.

By (C3) we mean that, if we concatenate u_+ with a cylinder corresponding to an upward gradient trajectory that starts at $(0, -\frac{1}{4})$ so that we have a map C from γ to e , then the Fredholm and ECH indices of C are 1. (C3) implies that curves of \mathcal{M}^{MB} are isolated modulo \mathbb{R} -translation and are embedded.

Next let

$$\mathcal{M}_\epsilon := \mathcal{M}_{J_{f_\epsilon}} := \mathcal{M}_{J_{f_\epsilon}}^{I=\text{ind}=1}(\gamma, e)$$

be the moduli space of J_{f_ϵ} -holomorphic maps $u: (\dot{F}, j) \rightarrow \mathbb{R} \times M$ modulo domain automorphisms, where (C0), (C1) (with u instead of u_+) and the following hold:

- (C2') u limits to the negative elliptic orbit e obtained by perturbing the Morse–Bott family.
- (C3') u has Fredholm and ECH index 1.

We also remark that the moduli spaces \mathcal{M}^{MB} and \mathcal{M}_ϵ can be made Morse–Bott regular or regular by perturbing J_f and J_{f_ϵ} outside of $[-c, c] \times T^2$.

Holomorphic curves near the Morse–Bott torus

Claim A.1.3 *The equation $\bar{\partial}_{J_{f_\epsilon}} u = 0$ for a map¹⁸*

$$u: [\tilde{s}_0, \tilde{s}_1] \times S^1 \rightarrow \mathbb{R} \times S^1 \times A_c, \quad u(s, t) = (s, t, \eta(s, t)),$$

is equivalent to the equation

$$(A-1-3) \quad \mathcal{D}_\epsilon \eta := \frac{\partial \eta}{\partial s} + j_0 \frac{\partial \eta}{\partial t} - \nabla f_\epsilon(\eta) = 0,$$

where $j_0 = \begin{pmatrix} 0 & -1 \\ 1 & 0 \end{pmatrix}$ is the standard almost complex structure on A_c .

Proof We apply $\bar{\partial}_{J_{f_\epsilon}} = \partial_s + J_{f_\epsilon} \partial_t$ to $(s, t, \eta(s, t))$ to obtain

$$(A-1-4) \quad \begin{pmatrix} 1 \\ 0 \\ \partial \eta / \partial s \end{pmatrix} + J_{f_\epsilon} \begin{pmatrix} 0 \\ 1 \\ \partial \eta / \partial t \end{pmatrix} = \begin{pmatrix} 1 \\ 0 \\ \partial \eta / \partial s \end{pmatrix} + \begin{pmatrix} -1 \\ 0 \\ j_0 \partial \eta / \partial t - \nabla f_\epsilon(\eta) \end{pmatrix}.$$

This is because $J_{f_\epsilon}(\partial_t) = -\partial_s - j_0 X_{f_\epsilon}$ and $j_0 X_{f_\epsilon} = \nabla f_\epsilon$ (recall the sign in (A-1-1)). Hence

$$J_{f_\epsilon} \begin{pmatrix} 0 \\ 1 \\ 0 \end{pmatrix} = \begin{pmatrix} -1 \\ 0 \\ -\nabla f_\epsilon \end{pmatrix}. \quad \square$$

¹⁸We abuse notation and use coordinates (s, t) for both the cylindrical part of the domain and $\mathbb{R} \times S^1$. We also change the order of the coordinates from (y, θ, t) to (t, y, θ) . This has no effect on the orientations of M and A_c .

The claim holds also for $\epsilon = 0$: the equation $\bar{\partial}_{J_{f_\epsilon}} u = 0$ for a map $u(s, t) = (s, t, \eta(s, t))$ as above is equivalent to $\mathcal{D}_0 \eta = 0$, where

$$\mathcal{D}_0 \eta = \frac{\partial \eta}{\partial s} + j_0 \frac{\partial \eta}{\partial t} - \nabla f(\eta).$$

Remark A.1.4 To treat the case $N > 1$ we need to consider maps $u: [\tilde{s}_0, \tilde{s}_1] \times S^1 \rightarrow \mathbb{R} \times S_t^1 \times A_c$ which wind k times around S_t^1 for $k \leq N$. In that case we should write $u(s, t) = (ks, kt, \eta(s, t))$, but all estimates on η remain unchanged.

The following easy consequence of Claim A.1.3 provides the link between gradient trajectories and holomorphic curves:

Lemma A.1.5 Every gradient trajectory \mathcal{T} of f_ϵ (here we are allowing $\epsilon = 0$ and $f_0 = f$) admits a unique lift to a simply covered J_{f_ϵ} -holomorphic cylinder $u_{\mathcal{T}}$ whose projection to A_c is \mathcal{T} modulo reparametrization of the domain and \mathbb{R} -translations of $u_{\mathcal{T}}$.

Proof If $\eta: [\tilde{s}_0, \tilde{s}_1] \rightarrow A_c$ is a parametrization of \mathcal{T} satisfying $d\eta/ds = \nabla f_\epsilon(\eta)$, then $u_{\mathcal{T}}(s, t) := (s, t, \eta(s))$ satisfies $\bar{\partial}_{J_{f_\epsilon}} u_{\mathcal{T}} = 0$ by Claim A.1.3. On the other hand, one can immediately check that a simply covered map to $\mathbb{R} \times S^1 \times A_c$ that projects to \mathcal{T} must be of the form $(s, t) \mapsto (s, t, \eta(s))$ for some η up to reparametrizations and translations. \square

A.2 Main result

The main result of the appendix is the following:

Theorem A.2.1 If $\mathcal{M}_{J_f}^{\text{MB}}$ is Morse–Bott regular, then, for $a, b_0 > 0$ sufficiently small, there exist

- J'_f that agrees with J_f on $[-c, c] \times T^2$ and is arbitrarily close to J_f on $M - ([-c, c] \times T^2)$,
- $\epsilon > 0$ that is sufficiently small, and
- J'_{f_ϵ} that agrees with J_{f_ϵ} on $[-c, c] \times T^2$ and with J'_f on $M - ([-c, c] \times T^2)$

such that $\mathcal{M}_{J'_f}^{\text{MB}}$ is Morse–Bott regular, $\mathcal{M}_{J'_{f_\epsilon}}$ is regular, and there is a bijection between $\mathcal{M}_{J'_f}^{\text{MB}}$ and $\mathcal{M}_{J'_{f_\epsilon}}$.

Remark A.2.2 In the case where $\mathcal{M}_{J_f}^{\text{MB}}$ satisfies (C0), (C1), and the unconstrained end is replaced by a constrained end in (C2) and (C3), ie the negative end limits to a hyperbolic orbit after perturbation, we can simply glue in a trivial cylinder at the said end, since having constrained index means not including $\tilde{\partial}_\theta$ in (A-5-15) and Morse–Bott gluing then reduces to standard gluing.

Brief discussion on regularity We will not prove that, for all $\epsilon > 0$ sufficiently small, \mathcal{M}_ϵ is regular if \mathcal{M}^{MB} is Morse–Bott regular, although that is true. It suffices for our purposes to know that “for some $\epsilon > 0$ small and some J'_f and J'_{f_ϵ} , there is a bijection between $\mathcal{M}_{J'_f}^{\text{MB}}$ which is Morse–Bott regular and $\mathcal{M}_{J'_{f_\epsilon}}$ which is regular”.

We will explain the existence of J'_f and J'_{f_ϵ} such that $\mathcal{M}_{J'_f}^{\text{MB}}$ is Morse–Bott regular and $\mathcal{M}_{J'_{f_\epsilon}}$ is regular: Since J_f is Morse–Bott regular for $\mathcal{M}_{J_f}^{\text{MB}}$, the same holds for all J'_f that are sufficiently close to J_f on $M - ([-c, c] \times T^2)$ and agree with J_f on $[-c, c] \times T^2$. Next, we perturb J_{f_ϵ} to J'_{f_ϵ} on $M - ([-c, c] \times T^2)$ so that $\mathcal{M}_{J'_{f_\epsilon}}$ is regular. This is possible because the only Reeb orbits of $(\alpha, \omega_{J_\epsilon})$ inside $[-c, c] \times T^2$ come from the perturbation of the Morse–Bott torus, and therefore every holomorphic curve in $\mathcal{M}_{J'_{f_\epsilon}}$ intersects $M - ([-c, c] \times T^2)$, except for the two curves corresponding to the two flow lines on the Morse–Bott family, whose regularity can be easily checked by hand.

Let us fix an \mathbb{R} -invariant Riemannian metric on $\mathbb{R} \times M$ that agrees with the flat metric $ds^2 + dt^2 + dy^2 + d\theta^2$ on $\mathbb{R} \times [-1, 1] \times T^2$. All distances will be measured with respect to this metric.

Definition A.2.3 Let $\kappa > 0$. A curve $u: \dot{F} \rightarrow \mathbb{R} \times M$ in \mathcal{M}_ϵ is κ -close to breaking into $u_+: \dot{F} \rightarrow \mathbb{R} \times M$ in \mathcal{M}^{MB} and $u_{\mathcal{T}^\epsilon}: (-\infty, 0] \times S^1 \rightarrow \mathbb{R} \times M$, where \mathcal{T}^ϵ is an upward gradient trajectory of f_ϵ , if

- (i) on the complement of a negative cylindrical end $(-\infty, 0] \times S^1$ of \dot{F} , the maps u and u_+ (obtained from u_+ by a suitable translation in the domain if \dot{F} is a cylinder and a suitable \mathbb{R} -translation in the target) are a distance $\leq \kappa$ apart;
- (ii) on $(-\infty, 0] \times S^1$, the maps u and $u_{\mathcal{T}^\epsilon}^*$ (obtained from $u_{\mathcal{T}^\epsilon}$ by a suitable \mathbb{R} -translation in the target) are a distance $\leq \kappa$ apart.

Let $u_+: (\dot{F}, j) \rightarrow \mathbb{R} \times M$ be an element of \mathcal{M}^{MB} . In what follows, we may assume without loss of generality that:

- (C4) u_+ limits to the Morse–Bott orbit \mathfrak{o} over the point $(0, 0)$ from the positive y -direction at the negative end.

This is justified as follows: The quotient $\mathcal{M}^{\text{MB}}/\mathbb{R}$ by \mathbb{R} -translations in the target is a finite set by (C3). Let $\mathcal{E}: \mathcal{M}^{\text{MB}}/\mathbb{R} \rightarrow \mathcal{N}$ be the map that sends $[u]$ to the orbit of \mathcal{N} that u limits to at the negative end. Since the image of \mathcal{E} is a finite set, we can parametrize $\mathcal{N} \cong \mathbb{R}/\mathbb{Z}$ such that $\mathcal{E}([u]) \in [-\frac{1}{6}, \frac{1}{6}]$ for all $u \in \mathcal{M}^{\text{MB}}$. Since our proof works in the same way as long as $\mathcal{E}([u])$ is in the interior of the interval $\{\theta \in \mathbb{R}/\mathbb{Z} \mid \bar{g}'_{\mathcal{N}}(\theta) = 1\}$ (refer to (P2) for the definition of $\bar{g}_{\mathcal{N}}$), we normalize $\mathcal{E}([u]) = 0$. Moreover, approaching $\theta = 0$ from the positive y -direction and the negative y -direction can be treated in the same way.

Notation A.2.4 Let \mathcal{T}_0^ϵ denote the (upward) gradient trajectory of f_ϵ that goes from $(0, -\frac{1}{4})$ to $(0, 0)$.

Theorem A.2.1 is an immediate consequence of the following theorems, which are proved in Sections A.7 and A.8, together with the above discussion on regularity:

Theorem A.2.5 Suppose $a, b_0 > 0$ are small. If \mathcal{M}^{MB} is Morse–Bott regular, then, for all $\epsilon > 0$ sufficiently small, there exists $u \in \mathcal{M}_\epsilon$ that is κ -close to breaking into u_+ and $u_{\mathcal{T}_0^\epsilon}$.

Theorem A.2.6 Suppose $a, b_0 > 0$ are small. If \mathcal{M}^{MB} is Morse–Bott regular and \mathcal{M}_ϵ is regular, then there exists $\kappa > 0$ such that, for all $\epsilon > 0$ sufficiently small and $u, v \in \mathcal{M}_\epsilon$ that are κ -close to breaking into u_+ and $u_{\mathcal{T}_0^\epsilon}$, $u = v$ modulo \mathbb{R} -translation in the target and domain translation if the domain is $\mathbb{R} \times S^1$.

Remark A.2.7 The assumptions

- (i) there is only one Morse–Bott torus $T_{\mathcal{N}}$ and it is negative, and
- (ii) u_+ limits to γ at the positive end and \mathcal{N} at the negative end,

are only to make the notation simpler, since gluing each pair of ends can be done more or less independently. This is due to the fact that the magnitude of the error that comes from a pair \mathfrak{P} of glued ends and needs to be inverted in the Newton iteration decays exponentially with respect to the distance to the gluing region of \mathfrak{P} .

A.3 Asymptotic operator

On $B := [-b_0, b_0] \times [-\frac{1}{6}, \frac{1}{6}] \subset A_c$, we have $\bar{g}'_{\mathcal{N}}(\theta) = 1$ by (P2) and $\phi(y) = 1$ by (P3'). Then $\nabla f_\epsilon = y\partial_y + \epsilon\partial_\theta$ and the equation $\mathcal{D}_\epsilon\eta = 0$ becomes the linear equation

$$\frac{\partial\eta}{\partial s} + j_0 \frac{\partial\eta}{\partial t} - \begin{pmatrix} \eta_1 \\ \epsilon \end{pmatrix} = 0,$$

or

$$(J_{f_\epsilon}) \quad \frac{\partial\eta}{\partial s} - A\eta = \begin{pmatrix} 0 \\ \epsilon \end{pmatrix}, \quad A\eta = -j_0 \frac{\partial\eta}{\partial t} + \begin{pmatrix} 1 & 0 \\ 0 & 0 \end{pmatrix} \eta,$$

where $j_0 = \begin{pmatrix} 0 & -1 \\ 1 & 0 \end{pmatrix}$, $\eta = (\eta_1, \eta_2)$, and A is the asymptotic operator for the negative end of u_+ that goes to the Morse–Bott family \mathcal{N} . Here we are regarding S^1 as $[-\frac{1}{2}, \frac{1}{2}] \subset \mathbb{R}$, so that $\eta \subset A_c$ is regarded in \mathbb{R}^2 and the matrix multiplication by $\begin{pmatrix} 1 & 0 \\ 0 & 0 \end{pmatrix}$ makes sense.

Similarly, a J_f -holomorphic map $(s, t) \mapsto (s, t, \eta(s, t))$ with $\eta(s, t) \in A_c$ is equivalent to

$$(J_f) \quad \mathcal{D}_0\eta = \frac{\partial\eta}{\partial s} - A\eta = 0.$$

Remark A.3.1 In the region where $\mathcal{D}_\epsilon\eta = 0$ is equivalent to (J_{f_ϵ}) , a solution of (J_f) can be converted to a solution of (J_{f_ϵ}) by adding $\begin{pmatrix} 0 \\ \epsilon s + C \end{pmatrix}$.

From now on we will write the components of η as row vectors if there is no confusion.

Claim A.3.2 The eigenfunctions of A can be arranged as

$$\dots, g_{-2}, g_{-1}, g_0 = (0, 1), g_1 = (1, 0), g_2, \dots,$$

normalized to have unit L^2 norm, with corresponding eigenvalues

$$\dots \leq \lambda_{-2} \leq \lambda_{-1} < \lambda_0 = 0 < \lambda_1 = 1 < \lambda_2 \leq \dots,$$

where, if λ is any of $\lambda_{2n} = \lambda_{2n+1}$ or $\lambda_{-2n} = \lambda_{-2n+1}$, then $\lambda(\lambda - 1) = (2\pi n)^2$ and

$$\begin{aligned} g_{2n} & \text{ is a multiple of } \left(\frac{2\pi n}{\lambda_{2n}-1} \cos(2\pi nt), \sin(2\pi nt) \right), \\ g_{2n+1} & \text{ is a multiple of } \left(\frac{2\pi n}{\lambda_{2n}-1} \sin(2\pi nt), -\cos(2\pi nt) \right). \end{aligned}$$

Proof If λ is an eigenvalue of A , then

$$\begin{pmatrix} 0 & 1 \\ -1 & 0 \end{pmatrix} \begin{pmatrix} y'(t) \\ \theta'(t) \end{pmatrix} + \begin{pmatrix} y(t) \\ \theta(t) \end{pmatrix} = \lambda \begin{pmatrix} y(t) \\ \theta(t) \end{pmatrix},$$

which is equivalent to $\theta'(t) = (\lambda - 1)y(t)$, $-y'(t) = \lambda\theta(t)$. Hence $\theta''(t) = (1 - \lambda)\lambda\theta(t)$. If $\theta(t)$ is to be 1-periodic, $\lambda = 0, 1, \lambda > 1$ or $\lambda < 0$. In the latter two cases, $\theta(t)$ is a translate of $\sin(2\pi nt)$ and $y(t) = 2\pi n/(\lambda - 1)$ times a translate of $\cos(2\pi nt)$ and $(2\pi n)^2 = \lambda(\lambda - 1)$. \square

We can then write a solution $\eta(s, t)$ of (J_f) as a Fourier series

$$(A-3-1) \quad \eta(s, t) = \sum_{i=-\infty}^{\infty} c_i e^{\lambda_i s} g_i(t).$$

A clarification of the meaning of (A-3-1) is in order: the eigenfunctions g_i take values in $T_{(0,0)}A_c \cong \mathbb{R}^2$, while η takes values in $A_c \cong [-c, c] \times S^1$. Thus, in the equality we have tacitly identified a neighborhood of $(0, 0)$ in $T_{(0,0)}A_c$ with a neighborhood of $(0, 0)$ in A_c using the identification of S^1 with a quotient of $[-\frac{1}{2}, \frac{1}{2}]$ fixed at the beginning of the appendix.

A.4 Pregluing

Let $u_+ : \dot{F} \rightarrow \mathbb{R} \times M$ be a J_f -holomorphic map representing an element of \mathcal{M}^{MB} . We fix a cylindrical end $(-\infty, s_0] \times S^1$ of \dot{F} corresponding to the orbit \mathfrak{o} on which u_+ takes the form $u_+(s, t) = (s, t, \eta_+(s, t))$, $\eta_+(s, t) \in A_c$. In view of (C4) we can write

$$(A-4-1) \quad \eta_+(s, t) = \sum_{i=1}^{\infty} c_i e^{\lambda_i s} g_i(t),$$

where $c_1 > 0$. The condition $c_1 \neq 0$ holds for a generic J_f because the moduli space \mathcal{M}^{MB} is one-dimensional. This is proved in the same way as [Hutchings and Taubes 2009a, Theorem 4.1], which treats the contact case. We further assume that $c_1 > 0$ since the $c_1 < 0$ case can be treated in the same way. Finally, we can assume that (A-4-1) has no $i = 0$ term because we assumed that \mathfrak{o} is the orbit over $(0, 0)$.

Definition A.4.1 Let $T_0 = T_0(a)$ and $T_1 = T_1(b)$ be real numbers such that

$$(A-4-2) \quad c_1 e^{-\lambda_1 T_0} g_1 = \left(\frac{1}{2}a, 0\right), \quad c_1 e^{-\lambda_1 T_1} g_1 = (b, 0).$$

Note that $T_1(b) \rightarrow \infty$ as $b \rightarrow 0$.

(†₁) We choose $a, b_0 > 0$, with $b_0 < \frac{1}{4}a$, to be sufficiently small that $T_0 > 0$ and, for all $b < b_0$,

$$\eta_+|_{s \leq -T_0} \subset A_a, \quad \eta_+|_{-T_0 \leq s \leq s_0} \subset A_c \cap \{y > 2b_0\} \quad \text{and} \quad \eta_+|_{s \leq -T_1} \subset B.$$

The choice of a is made possible by the fact that $\sum_{i=2}^{\infty} c_i e^{\lambda_i s} g_i(t)$ decays exponentially at a rate which is faster than $c_1 e^{\lambda_1 s} g_1(t)$. From now on, a and T_0 are fixed constants, while b and $T_1(b)$ are, for the moment, still allowed to vary and will be fixed at a later time.

Remark A.4.2 Since the perturbation of f , and therefore of R_f , given in (A-1-2) depends on a and b_0 by conditions (P2) and (P3'), it is important that \mathcal{M}^{MB} is finite, so that we can find a and b_0 which satisfy (\dagger_1) for every $u_+ \in \mathcal{M}^{\text{MB}}$.

Let $\eta_-^\epsilon: \mathbb{R} \rightarrow A_a$ be a parametrization of the gradient flow trajectory of f_ϵ from $(0, -\frac{1}{4})$ to $(0, \frac{1}{4})$ solving the Cauchy problem

$$\begin{cases} \frac{d\eta_-^\epsilon}{ds} = \nabla f_\epsilon(\eta_-^\epsilon), \\ \eta_-^\epsilon(-T_1) = (0, 0), \end{cases}$$

and let $u_-^\epsilon(s, t) = (s, t, \eta_-^\epsilon(s))$. We trivially extend η_-^ϵ to a function $\eta_-^\epsilon: \mathbb{R} \times S^1 \rightarrow A_a$ by $\eta_-^\epsilon(s, t) = \eta_-^\epsilon(s)$.

Definition A.4.3 Let $T_2 = T_2(\epsilon)$ be a real number such that $T_1 < T_2$ and $\eta_-^\epsilon|_{-T_2 \leq s \leq -T_1} \subset B$.

Note that $T_2(\epsilon) \rightarrow +\infty$ as $\epsilon \rightarrow 0$.

Let $\beta: \mathbb{R} \rightarrow [0, 1]$ be a nondecreasing function such that $\beta(s) = 0$ if $s \leq 0$ and $\beta(s) = 1$ if $s \geq 1$. The pregluing $u_*^{\epsilon, \alpha}$ (note the Fraktur symbol α is different from the parameter a) will depend on ϵ and an extra real parameter $\alpha \in [-\alpha_0, \alpha_0]$, where α_0 is independent of b and ϵ , and small enough that $\eta_-^\epsilon(-T_1 + \alpha/\epsilon)$ is contained in B , where ∇f_ϵ is constant. Then we define

$$(A-4-3) \quad u_*^{\epsilon, \alpha}(s, t) := \begin{cases} u_+(s, t) & \text{on } \dot{F} - (-\infty, -T_0] \times S^1, \\ (s, t, \eta_*^{\epsilon, \alpha}(s, t)) & \text{on } (-\infty, -T_0] \times S^1, \end{cases}$$

where

$$(A-4-4) \quad \eta_*^{\epsilon, \alpha}(s, t) = \begin{cases} \eta_+(s, t) + \beta\left(\frac{s+T_0}{-T_1+T_0}\right)(0, \epsilon(s+T_1)) + \beta(-s-T_0)(0, \alpha) & \text{on } [-T_1, -T_0] \times S^1, \\ \eta_-^\epsilon(s + \alpha/\epsilon, t) + \beta(s+T_2) \cdot \eta_+(s, t) & \text{on } (-\infty, -T_1] \times S^1. \end{cases}$$

Observe that $\eta_-^\epsilon(s + \alpha/\epsilon, t) = (0, \epsilon(s + T_1) + \alpha)$ on $[-T_2, -T_1] \times S^1$ since $\nabla f_\epsilon(y, \theta) = (y, \epsilon)$ and $\eta_-^\epsilon(-T_1, t) = (0, 0)$. Hence the two definitions agree along $s = -T_1$. Therefore $u_*^{\epsilon, \alpha}$ coincides with u_+ for $s \geq -T_0$, with the lift of a gradient trajectory of f_ϵ for $s \leq -T_2$, and interpolates between the two for $s \in [-T_2, -T_0]$. The interpolation is performed in three steps: for $s \in [-T_0 - 1, -T_0]$ the holomorphic curve is pushed in the θ -direction (ie along the Morse–Bott family) by a small amount α ; for $s \in [-T_1, -T_0]$ a perturbation corresponding to the gradient trajectory is slowly turned on and added to u_+ ; for $s \in [-T_2 + 1, -T_1]$ the preglued curve $u_*^{\epsilon, \alpha}$ is the sum of u_+ and the lift of a gradient trajectory of f_ϵ ; and for $s \in [-T_2, -T_2 + 1]$ the contribution of u_+ is turned off.

(\dagger_2) We choose $\epsilon = \epsilon(b) > 0$ such that

$$\lim_{b \rightarrow 0} \epsilon(b) e^{T_1(b)} T_1(b) = 0.$$

Note that T_0 has become a constant after we fixed a , while T_1 depends on b and T_2 depends on ϵ .

Lemma A.4.4 *If $u_*^{\epsilon,\alpha}$ is defined by (A-4-3) and (A-4-4), then $\bar{\partial}_{J_{f_\epsilon}} u_*^{\epsilon,\alpha}$ is supported on*

- (1) $([-T_2, -T_2 + 1] \times S^1) \cup ([-T_1, -T_0] \times S^1)$; and
- (2) the “thick” parts of the domain of u_+ , ie $\dot{F} - (-\infty, T_0] \times S^1$, where the curve may still enter the region $y \in [-2b_0, 2b_0]$.¹⁹

Proof Note that $\bar{\partial}_{J_{f_\epsilon}} u_*^{\epsilon,\alpha} = 0$

- (a) on $\dot{F} - (-\infty, -T_0] \times S^1$, away from the region described in (2), where $u_*^{\epsilon,\alpha} = u_+$ and $f_\epsilon = f$, and
- (b) on $(-\infty, -T_2] \times S^1$, where $u_*^{\epsilon,\alpha}$ coincides with the $\bar{\partial}_{J_{f_\epsilon}}$ -holomorphic lift of a gradient trajectory of f_ϵ .

(For (a), note that f_ϵ and f differ only when $y \in [-2b_0, 2b_0]$ by (A-1-2) and (P3'), but we are assuming (\dagger_1) , which ensures that $\eta_+(T_0, t)$ has y -coordinate $> 2b_0$.) Therefore $\bar{\partial}_{J_{f_\epsilon}} u_*^{\epsilon,\alpha}$ is supported in $[-T_2, -T_0] \times S^1$, where $\bar{\partial}_{J_{f_\epsilon}} u_*^{\epsilon,\alpha} = 0$ is equivalent to $\mathcal{D}_\epsilon \eta_*^{\epsilon,\alpha} = 0$. We claim that $\mathcal{D}_\epsilon \eta_*^{\epsilon,\alpha} = 0$ on $[-T_2 + 1, -T_1] \times S^1$. In fact, in that region,

$$\eta_*^{\epsilon,\alpha} = \eta_-^{\epsilon,\alpha} + \eta_+$$

by (A-4-4) and the definition of β . Moreover, $\eta_*^{\epsilon,\alpha}$ takes values in B by condition (\dagger_1) and Definition A.4.3, and in B we have

$$\mathcal{D}_\epsilon = \mathcal{D}_0 + (0, \epsilon),$$

where \mathcal{D}_0 is linear by (J_{f_ϵ}) . Thus,

$$\mathcal{D}_\epsilon(\eta_*^{\epsilon,\alpha}) = \mathcal{D}_0(\eta_-^{\epsilon,\alpha}) + \mathcal{D}_0(\eta_+) + (0, \epsilon) = \mathcal{D}_\epsilon(u_-^{\epsilon,\alpha}) + \mathcal{D}_0(\eta_+) = 0$$

because $\mathcal{D}_\epsilon(u_-^{\epsilon,\alpha}) = \mathcal{D}_0(\eta_+) = 0$. □

A.5 Function spaces

Let us introduce the notation

$$(A-5-1) \quad \eta_-^{\epsilon,\alpha}(s, t) = \eta_-^\epsilon(s + \alpha/\epsilon, t), \quad u_-^{\epsilon,\alpha}(s, t) = (s, t, \eta_-^{\epsilon,\alpha}(s, t)).$$

In this subsection we describe the linearized $\bar{\partial}$ -operators D_+ and $D_-^{\epsilon,\alpha}$ for u_+ and $u_-^{\epsilon,\alpha}$.

Since we are assuming that the ECH and Fredholm indices of u_+ and $u_-^{\epsilon,\alpha}$ are both 1, they are embedded and admit normal bundles. Let N_+ be a J_f -invariant normal bundle to u_+ in $\mathbb{R} \times M$ such that $N_+ = TA_a$ on $(-\infty, -T_0] \times S^1$, let $N_-^{\epsilon,\alpha} = TA_a$ be the normal bundle to $u_-^{\epsilon,\alpha}$ in $\mathbb{R} \times [-a, a] \times T^2$, and let $N_*^{\epsilon,\alpha}$ be the normal bundle to $u_*^{\epsilon,\alpha}$ that agrees with N_+ on $\dot{F} - (-\infty, -T_0] \times S^1$ and with TA_a on $(-\infty, -T_0] \times S^1$.

A.5.1 Exponential maps Let $\mathbb{D}_\kappa N_+$ denote the disk bundle of N_+ of radius $\kappa > 0$, measured with respect to g . Writing an element of N_+ as $(x, \xi(x))$, where $x \in \dot{F}$ and $\xi(x) \in N_+(u_+(x))$, for $\kappa > 0$ small we choose an exponential map

$$\exp_{u_+} : \mathbb{D}_\kappa N_+ \rightarrow \mathbb{R} \times M$$

¹⁹In this case the error is extremely small, of total size $C\epsilon$, and we will not mention it further.

such that $\exp_{u_+}(x, 0) = u_+(x)$, $d_{(x,0)} \exp_{u_+}(0, \zeta) = \zeta(u_+(x))$ for a section ζ of N^+ , and

$$\exp_{u_+}(x, \xi(x)) = (s(x), t(x), \eta_+(x) + \xi(x))$$

when $u_+(x) = (s(x), t(x), \eta_+(x))$ and $x \in (-\infty, -T_0] \times S^1$. We also define

$$\exp_{u_{\pm}^{\epsilon, a}}: \mathbb{D}_\kappa N_{\pm}^{\epsilon, a} \rightarrow \mathbb{R} \times [-a, a] \times T^2, \quad (x, \xi(x)) \mapsto (s(x), t(x), \eta_{\pm}^{\epsilon, a}(x) + \xi(x)).$$

Finally, we define $\exp_{u_*^{\epsilon, a}}$ on $\mathbb{D}_\kappa N_*^{\epsilon, a}$ so that it agrees with \exp_{u_+} on $\dot{F} - (-\infty, -T_0] \times S^1$ and satisfies

$$(x, \xi(x)) \mapsto (s(x), t(x), \eta_*^{\epsilon, a}(x) + \xi(x))$$

on $(-\infty, -T_0] \times S^1$. In particular, $\exp_{u_*^{\epsilon, a}}$ coincides with $\exp_{u_{\pm}^{\epsilon, a}}$ on $(-\infty, -T_2) \times S^1$.

A.5.2 Normal $\bar{\partial}$ -equations Instead of using the full $\bar{\partial}$ -operator on sections of $u_+^* T(\mathbb{R} \times M)$ and $(u_{\pm}^{\epsilon, a})^* T(\mathbb{R} \times M)$, following [Hutchings and Taubes 2009a] we will use the normal $\bar{\partial}$ -operators which act on sections of N_+ and $N_{\pm}^{\epsilon, a}$. *The primary purpose of using the normal $\bar{\partial}$ -operators, assuming the curves are embedded, is to simplify the notation*, since the Teichmüller space parameters are automatically taken care of. More precisely, let L be the total linearized $\bar{\partial}$ -operator — this includes the Teichmüller space parameters — and let L_N be the normal linearized $\bar{\partial}$ -operator L_N . Then $\text{coker } L \simeq \text{coker } L_N$ and $\ker L_N \simeq (\ker L)/V$, where V is the subspace generated by the infinitesimal generators of the reparametrizations of the domain.

By standard local existence results of holomorphic disks, for $\kappa > 0$ small there exists a foliation of $\exp_{u_+}(\mathbb{D}_\kappa N_+)$ by J_f -holomorphic disks such that the holomorphic disk passing through $u_+(x)$ is tangent to $N_+(u_+(x))$. We can therefore adjust the map \exp_{u_+} so that the fibers of $\mathbb{D}_\kappa N_+$ are mapped to holomorphic disks, use local coordinates (σ, τ, ξ) on $\exp_{u_+}(\mathbb{D}_\kappa N_+)$, where $\sigma + i\tau$ are holomorphic coordinates on \dot{F} and ξ is the fiber coordinate, and write

$$J_f(\sigma, \tau, \xi) = \begin{pmatrix} \tilde{j}(\sigma, \tau, \xi) & 0 \\ X(\sigma, \tau, \xi) & j_0 \end{pmatrix},$$

where $\tilde{j}(\sigma, \tau, 0) = j_0$ and $X(\sigma, \tau, 0) = 0$. Since $\tilde{j}^2 = -I$, we have

$$\tilde{j}(\sigma, \tau, \xi) = \begin{pmatrix} a(\sigma, \tau, \xi) & c(\sigma, \tau, \xi) \\ b(\sigma, \tau, \xi) & -a(\sigma, \tau, \xi) \end{pmatrix}$$

and $\det \tilde{j} = 1$. Also $X\tilde{j} + j_0X = 0$.

We derive the normal $\bar{\partial}$ -equation for a section ξ of N_+ such that

$$(A-5-2) \quad \bar{\partial}_{J_f} \exp_{u_+} \xi = 0.$$

We recall that $\bar{\partial}_{J_f} u = du + J_f \circ du \circ j$, where j is a complex structure on the domain of u , and therefore (A-5-2) is an equation for a pair (j, ξ) , where j is a complex structure on \dot{F} . Then solving (A-5-2) is

equivalent to solving for $A(\sigma, \tau, \xi)$, $B(\sigma, \tau, \xi)$, and $\xi(\sigma, \tau)$ in

$$(A-5-3) \quad \left(\frac{\partial}{\partial \sigma} + J_f(\sigma, \tau, \xi) \left(A(\sigma, \tau, \xi) \frac{\partial}{\partial \sigma} + B(\sigma, \tau, \xi) \frac{\partial}{\partial \tau} \right) \right) \begin{pmatrix} \sigma \\ \tau \\ \xi \end{pmatrix} = 0.$$

Here the adjustment of the domain complex structure is equivalent to solving for $A(\sigma, \tau, \xi)$ and $B(\sigma, \tau, \xi)$. One easily verifies that

$$A(\sigma, \tau, \xi) = a(\sigma, \tau, \xi) \quad \text{and} \quad B(\sigma, \tau, \xi) = b(\sigma, \tau, \xi)$$

are the unique functions such that the (σ, τ) -component of (A-5-3) holds. Then the ξ -component of (A-5-3) is the normal $\bar{\partial}$ -equation for the section ξ of N_+ :

$$(A-5-4) \quad \bar{\partial}_{N_+, f} \xi := \frac{\partial \xi}{\partial \sigma} + j_0 \left(a(\sigma, \tau, \xi) \frac{\partial \xi}{\partial \sigma} + b(\sigma, \tau, \xi) \frac{\partial \xi}{\partial \tau} \right) + X(\sigma, \tau, \xi) \begin{pmatrix} a(\sigma, \tau, \xi) \\ b(\sigma, \tau, \xi) \end{pmatrix} = 0$$

such that

$$(A-5-5) \quad a(\sigma, \tau, 0) = 0, \quad b(\sigma, \tau, 0) = 1, \quad \text{and} \quad X(\sigma, \tau, 0) = 0.$$

Next we derive the normal $\bar{\partial}$ -equation for the section ξ of $N_{\epsilon, a}$ such that

$$\bar{\partial}_{J_{f_\epsilon}} \exp_{u_{\epsilon, a}} \xi = 0.$$

Recall that we write $\exp_{u_{\epsilon, a}} \xi = (s, t, \eta_{\epsilon, a} + \xi)$ on $\mathbb{R} \times [-a, a] \times T^2$. Since $\bar{\partial}_{J_{f_\epsilon}} u_{\epsilon, a} = 0$, the normal $\bar{\partial}$ -equation for ξ has the explicit expression

$$(A-5-6) \quad \begin{aligned} \bar{\partial}_{N_{\epsilon, a}, f_\epsilon} \xi &:= \mathcal{D}_\epsilon(\eta_{\epsilon, a} + \xi) = \mathcal{D}_\epsilon(\eta_{\epsilon, a} + \xi) - \mathcal{D}_\epsilon(\eta_{\epsilon, a}) \\ &= \frac{\partial \xi}{\partial s} + j_0 \frac{\partial \xi}{\partial t} - \nabla f_\epsilon(\eta_{\epsilon, a} + \xi) + \nabla f_\epsilon(\eta_{\epsilon, a}) = 0, \end{aligned}$$

by Claim A.1.3.

Finally, $\bar{\partial}_{N_{\epsilon, a}, f_\epsilon} \xi$ for the section ξ of $N_{\epsilon, a}$ agrees with $\bar{\partial}_{N_+, f} \xi$ on $\dot{F} - (-\infty, -T_0] \times S^1$ and with $\mathcal{D}_\epsilon(\eta_* + \xi)$ on $(-\infty, -T_0] \times S^1$ by Claim A.1.3.

The linearized operators for $\bar{\partial}_{N_+, f}$, $\bar{\partial}_{N_{\epsilon, a}, f_\epsilon}$, and $\bar{\partial}_{N_{\epsilon, a}, f_\epsilon}$ will be denoted by D_+ , $D_{\epsilon, a}$, and $D_{\epsilon, a}^*$. Next we will describe the proper function-theoretic setup for these operators.

A.5.3 Morrey spaces The function spaces that we use are *Morrey spaces*, following [Hutchings and Taubes 2009a, Section 5.5]. Let $u: \dot{F} \rightarrow \mathbb{R} \times M$ be a finite-energy holomorphic curve. On \dot{F} we choose a Riemannian metric such that the ends are isometric to $\mathbb{R}/\mathbb{Z} \times [0, \infty)$ with the product metric. On $\mathbb{R} \times M$ we continue to use the \mathbb{R} -invariant Riemannian metric from before.

The *Morrey space* $\mathcal{H}_0(\dot{F}, \Lambda^{0,1} N_+)$ is the Banach space which is the completion of the compactly supported sections of $\Lambda^{0,1} N_+$ with respect to the norm

$$(A-5-7) \quad \|\xi\| = \left(\int_{\dot{F}} |\xi|^2 \right)^{1/2} + \left(\sup_{x \in \dot{F}} \sup_{\rho \in (0, 1]} \rho^{-1/2} \int_{B_\rho(x)} |\xi|^2 \right)^{1/2},$$

where $B_\rho(x) \subset \dot{F}$ is the ball of radius ρ about x . Similarly, $\mathcal{H}_1(\dot{F}, N_+)$ is the completion of the compactly supported sections of N_+ with respect to

$$(A-5-8) \quad \|\xi\|_* = \|\nabla\xi\| + \|\xi\|.$$

Although Morrey spaces are not used as frequently as Sobolev spaces, they satisfy the analog of the usual Sobolev embedding theorem (Lemma A.5.1) and have the advantage that *we only need to do elementary L^2 -type estimates instead of more complicated L^p -type estimates.*

The analog of the usual Sobolev embedding theorem is the following:²⁰

Lemma A.5.1 *There is a bounded linear map*

$$\mathcal{H}_1(\dot{F}, N_+) \rightarrow C^0(\dot{F}, N_+) \cap L^\infty(\dot{F}, N_+), \quad \xi \mapsto \xi.$$

Proof If $\xi \in \mathcal{H}_1(\dot{F}, N_+)$ and $K \subset \dot{F}$ is a subdomain, then let us define

$$|\xi|_{C^{0,1/4},K} = \sup_{x \neq y \in K} \frac{|\xi(x) - \xi(y)|}{|x - y|^{1/4}}.$$

The lemma is a consequence of [Morrey 1966, Theorem 3.5.2], which implies²¹ that, for any compact subdomain $K \subset \dot{F}$, there exists C_K such that

$$(A-5-9) \quad |\xi|_{C^{0,1/4},K} \leq C_K \left(\sup_{x \in \dot{F}} \sup_{\rho \in (0,1]} \rho^{-1/2} \int_{B_\rho(x)} |\nabla\xi|^2 \right)^{1/2} \leq C_K \|\xi\|_*.$$

This implies that any $\xi \in \mathcal{H}_1(\dot{F}, N_+)$ is continuous.

Since \dot{F} has cylindrical ends, we can write $\dot{F} = K_0 \cup K_1 \cup K_2 \cup \dots$, where all the K_i are compact connected subdomains and K_1, K_2, \dots are annuli of the form \mathbb{R}/\mathbb{Z} times a unit interval. For each K_i and $x \neq y \in K_i$, we have

$$(A-5-10) \quad |\xi(x) - \xi(y)| \leq C_{K_i} \|\xi\|_* |x - y|^{1/4} \leq C(C')^{1/4} \|\xi\|_*,$$

where $C = \max\{C_{K_0}, C_{K_1}\}$, since $C_{K_1} = C_{K_2} = \dots$ and C' is the supremum of the diameters of K_i for $i = 0, 1, \dots$. Since ξ is continuous, on each K_i there exists x_i such that

$$(A-5-11) \quad |\xi(x_i)| = \|\xi|_{K_i}\|_{L^2} / \text{vol}(K_i) \leq \|\xi\|_* / C'',$$

where $C'' = \inf_i \text{vol}(K_i) > 0$. Inequalities (A-5-10) and (A-5-11) together imply that there exists a constant $c > 0$ which is independent of ξ and such that $|\xi(x)| \leq c \|\xi\|_*$ for all $x \in \dot{F}$. □

²⁰The lemma is stated slightly differently from [Hutchings and Taubes 2009a, Lemma 5.3].

²¹Morrey's theorem is stated for a Euclidean ball of radius R , but applies equally well to our setting. We take $p = 2$, $\nu = 2$ and $\mu = \frac{1}{4}$ in the theorem.

Given $\delta > 0$ sufficiently small, we define a smooth weight function

$$(A-5-12) \quad g_\delta: \dot{F} \rightarrow \mathbb{R}^+, \quad \begin{cases} g_\delta(x) = 1 & \text{on } \dot{F} - (-\infty, -T_0 + 1] \times S^1, \\ g_\delta(s, t) = e^{\delta|s+T_0|} & \text{for } s \leq -T_0. \end{cases}$$

Also define the smooth weight function

$$(A-5-13) \quad h_\delta: \mathbb{R} \times S^1 \rightarrow \mathbb{R}^+, \quad (s, t) \mapsto e^{-\delta(s+T_0)}.$$

Note that h_δ agrees with g_δ for $s \leq -T_0$. We recall that T_0 has been fixed once and for all in Definition A.4.1 and (\dagger_0) . For our purposes we define $\lambda := \min(\lambda_1, |\lambda_{-1}|)$ and take δ such that $5\delta < \lambda$.

We also define the weighted Morrey spaces $\mathcal{H}_{1,g_\delta}(\dot{F}, N_+)$ and $\mathcal{H}_{0,g_\delta}(\dot{F}, \Lambda^{0,1}N_+)$ as the spaces of sections ξ (of the respective bundles) such that the weighted Morrey norms

$$(A-5-14) \quad \|\xi\|_{*,g_\delta} := \|\xi \cdot g_\delta\|_*, \quad \|\xi\|_{g_\delta} := \|\xi \cdot g_\delta\|$$

are finite. Observe that, since we are using normal bundles, it is not necessary to use weights except at the end which limits to the Morse–Bott orbit. The Morrey spaces for $N_-^{\epsilon,a}$ and $N_*^{\epsilon,a}$ (with and without weights) are defined analogously.

A.5.4 Linearized operators Let $\tilde{\partial}_\theta$ be a smooth section of N_+ which is equal to $\beta(-s - T_0)\partial_\theta$ on $s \leq -T_0$ and is zero elsewhere. We view D_+ as a bounded linear operator

$$(A-5-15) \quad D_+^\delta: \mathcal{H}_{1,g_\delta}(\dot{F}, N_+) \oplus \mathbb{R}\langle \tilde{\partial}_\theta \rangle \rightarrow \mathcal{H}_{0,g_\delta}(\dot{F}, \Lambda^{0,1}N_+), \quad (\xi, c\tilde{\partial}_\theta) \mapsto D_+(\xi + c\tilde{\partial}_\theta).$$

The term $\mathbb{R}\langle \tilde{\partial}_\theta \rangle$ is included since D_+^δ is the linearized operator for the Morse–Bott family $\mathcal{M}^{\text{MB}} = \mathcal{M}_{J_f}^{\text{ind}=1}(\mathcal{Y}; \mathcal{N})$ with an unconstrained negative end but the infinitesimal deformations parallel to the Morse–Bott family do not belong to the Morrey space with weights.

We write

$$(A-5-16) \quad \mathcal{H}_{+,\delta} = \mathcal{H}_{1,g_\delta}(\dot{F}, N_+) \quad \text{and} \quad \mathcal{H}'_{+,\delta} = D_+^\delta(\mathcal{H}_{+,\delta}) \subset \mathcal{H}_{0,g_\delta}(\dot{F}, \Lambda^{0,1}N_+),$$

and let $\bar{D}_+^\delta: \mathcal{H}_{+,\delta} \rightarrow \mathcal{H}'_{+,\delta}$ be the map induced by D_+^δ by restriction.

Let us define

$$(A-5-17) \quad \nu := -\beta'(-s - T_0)\partial_\theta.$$

Then ν has compact support in $\{-T_0 - 1 \leq s \leq -T_0\}$ and satisfies

$$D_+^\delta(0, 1) = D_+(\tilde{\partial}_\theta) = \nu.$$

Also observe that $\nu \notin \mathcal{H}'_{+,\delta}$ because D_+^δ is surjective and $\text{ind}(D_+^\delta) = 1$ with $\ker D_+^\delta \subset \mathcal{H}_{+,\delta}$, and $\nu \neq 0$. Then we can define the projection

$$(A-5-18) \quad \Pi: \mathcal{H}_{0,g_\delta}(\dot{F}, \Lambda^{0,1}N_+) \rightarrow \mathcal{H}'_{+,\delta}$$

with $\nu \in \ker \Pi$. Note that ν has compact support in $\{-T_0 - 1 \leq s \leq -T_0\}$, where it can be written as $\nu = -\beta'(-s - T_0)\partial_\theta$.

Remark A.5.2 The domain of D_+^δ is the tangent space to the Banach manifold

$$\mathcal{H}_{1,g_\delta}(\dot{F}, \mathbb{R} \times M) := \{\exp_u(\xi) \mid u \in \mathcal{C}, \xi \in \mathcal{H}_{1,g_\delta}(\dot{F}, N_+^u)\},$$

where \mathcal{C} is the space of smooth embeddings $u: \dot{F} \rightarrow \mathbb{R} \times M$ that agree with holomorphic maps parametrizing trivial holomorphic half-cylinders near each of the punctures; the positive ends of u and u_+ agree and the negative end of u limits to \mathcal{N} ; and N_+^u is the J_f -invariant normal bundle to u .

Linearizing (A-5-6), we obtain

$$(A-5-19) \quad D_-^{\epsilon,\alpha} \xi = \frac{\partial \xi}{\partial s} + j_0 \frac{\partial \xi}{\partial t} - (H f_\epsilon)(\eta_-^{\epsilon,\alpha}) \xi,$$

where $H f_\epsilon$ is the Hessian of f_ϵ .

We view $D_-^{\epsilon,\alpha}$ as a bounded linear operator

$$(A-5-20) \quad D_-^{\epsilon,\alpha}: \mathcal{H}_1(\mathbb{R} \times S^1, N_-^{\epsilon,\alpha}) \rightarrow \mathcal{H}_0(\mathbb{R} \times S^1, \Lambda^{0,1} N_-^{\epsilon,\alpha}).$$

Since the normal bundles $N_-^{\epsilon,\alpha}$ are trivialized, we can identify the domains and codomains of $D_-^{\epsilon,\alpha}$ for different values of ϵ and α . We abbreviate $\mathcal{H}_- = \mathcal{H}_1(\mathbb{R} \times S^1, N_-^{\epsilon,\alpha})$ and $\mathcal{H}'_- = \mathcal{H}_0(\mathbb{R} \times S^1, \Lambda^{0,1} N_-^{\epsilon,\alpha})$. Both D_+^δ and $D_-^{\epsilon,\alpha}$ are Fredholm of index 1.

We consider also operators

$$D_-^{\epsilon,\alpha,\delta}: \mathcal{H}_{1,h_\delta}(\mathbb{R} \times S^1, N_-^{\epsilon,\alpha}) \rightarrow \mathcal{H}_{0,h_\delta}(\mathbb{R} \times S^1, \Lambda^{0,1} N_-^{\epsilon,\alpha})$$

which have the same expression as $D_-^{\epsilon,\alpha}$ but act on the Morrey spaces with weights. We abbreviate $\mathcal{H}_{-,\delta} = \mathcal{H}_{1,h_\delta}(\mathbb{R} \times S^1, N_-^{\epsilon,\alpha})$ and $\mathcal{H}'_{-,\delta} = \mathcal{H}_{0,h_\delta}(\mathbb{R} \times S^1, \Lambda^{0,1} N_-^{\epsilon,\alpha})$.

Remark A.5.3 Sections $\xi \in \mathcal{H}_{-,\delta}$ can diverge as $s \rightarrow +\infty$ and therefore $\exp_{u_-^{\epsilon,\alpha}}(\xi)$ may not be well defined. This makes the spaces $\mathcal{H}_{-,\delta}$ unsuitable for the nonlinear analysis of the moduli space containing $u_-^{\epsilon,\alpha}$. However, they can still be used in the proof of Theorem A.2.1 because, for the purposes of gluing, what happens near the positive end of $u_-^{\epsilon,\alpha}$ is irrelevant. The reason we are using the operators $D_-^{\epsilon,\alpha,\delta}$ is so that we can take the limit of $D_-^{\epsilon,\alpha,\delta}$ as $\epsilon \rightarrow 0$ and obtain a Fredholm operator $D_-^{0,\alpha,\delta}$ of the same index in the limit. This would not be true if we worked without weights, as the operators $D_-^{\epsilon,\alpha}$ converge, for $\epsilon \rightarrow 0$, to an operator which is not Fredholm.

Lemma A.5.4 *If $\delta, \alpha_0 = \alpha_0(\delta)$ and $\epsilon_0 = \epsilon_0(\delta, \alpha_0)$ are sufficiently small subject to $0 \leq \epsilon_0 < \delta$, and $(\alpha, \epsilon) \in [-\alpha_0, \alpha_0] \times [0, \epsilon_0]$, then the operators $D_-^{\epsilon,\alpha,\delta}$ are invertible. Moreover, for a fixed δ , the norms of the inverse operators $(D_-^{\epsilon,\alpha,\delta})^{-1}$ are uniformly bounded on $[-\alpha_0, \alpha_0] \times [0, \epsilon_0]$.*

Proof The operators $D_-^{\epsilon,\alpha,\delta}: \mathcal{H}_{-,\delta} \rightarrow \mathcal{H}'_{-,\delta}$ (including for $\epsilon = \alpha = 0$, which is well defined because H_f is constant on $\{y = 0\}$) are conjugated to the operators

$$\tilde{D}_-^{\epsilon,\alpha,\delta} = D_-^{\epsilon,\alpha} + \delta \text{Id}: \mathcal{H}_- \rightarrow \mathcal{H}'_-.$$

The operator

$$\tilde{D}_-^{0,0,\delta} = \frac{\partial \eta}{\partial s} + j_0 \frac{\partial \eta}{\partial t} + \begin{pmatrix} -1 + \delta & 0 \\ 0 & \delta \end{pmatrix}$$

is Fredholm because, for δ small, its asymptotic operators are invertible. Moreover, $\tilde{D}_-^{0,0,\delta}$ has no spectral flow, and therefore $\text{ind}(\tilde{D}_-^{0,0,\delta}) = 0$. Hence $D_-^{0,0,\delta}$ is also a Fredholm operator of index zero.

By elliptic regularity all elements of $\ker D_-^{0,0,\delta}$ are smooth solutions of (J_f) , and from the Fourier series expansion (A-3-1) we see that no such solution has the correct growth for $s \rightarrow \pm\infty$ to belong to $\mathcal{H}_{-,\delta}$. Then $D_-^{0,0,\delta}$ is injective and therefore, having index zero, is invertible. Since

$$\|D_-^{\epsilon,\alpha,\delta} \xi - D_-^{0,0,\delta} \xi\|_{h_\delta} \leq C \|\xi\|_{*,h_\delta}$$

for a constant C which is independent of ϵ and α and invertibility is an open condition, for a fixed δ , all operators $D_-^{\epsilon,\alpha,\delta}$ are invertible when the conditions of the lemma are met. The uniform bound on the norms of $(D_-^{\epsilon,\alpha,\delta})^{-1}$ then follows by the continuity of taking the inverse. \square

A.6 Setting up the gluing

The gluing setup will follow [Bao and Honda 2023], which in turn is based on [Hutchings and Taubes 2009a].

Define smooth cutoff functions

$$(A-6-1) \quad \beta_+, \beta_- : \mathbb{R} \rightarrow [0, 1]$$

such that $\beta_+ + \beta_- = 1$ and $\beta_+(s) = 0$ for $s \leq -T_1$ and $\beta_+(s) = 1$ for $s \geq -T_0 - 1$. The cutoff functions β_\pm will depend on the parameter b and will be denoted by β_\pm^b when we want to make the dependence explicit. Let us write $-T_1(b)$ for $-T_1$ viewed as a function of b . Then:

(†₃) If $a > 0$ is fixed but we take $b \rightarrow 0$, then $-T_1(b) \rightarrow -\infty$ and we take β_\pm^b such that $|(\beta^b)'_\pm|_{C^0} \rightarrow 0$ as $b \rightarrow 0$.

Let ψ_+ and $\psi_-^{\epsilon,\alpha}$ be sections in $\mathcal{H}_{+,\delta}$ and $\mathcal{H}_{-,\delta}$ of sufficiently small norm. The goal is to deform the pregluing $u_*^{\epsilon,\alpha}$ to

$$(A-6-2) \quad u^{\epsilon,\alpha} = \exp_{u_*^{\epsilon,\alpha}}(\beta_+ \psi_+ + \beta_- \psi_-^{\epsilon,\alpha}),$$

and solve for ψ_+ and $\psi_-^{\epsilon,\alpha}$ in the equation $\Pi \partial_{N_*^{\epsilon,\alpha}, f_\epsilon}(\beta_+ \psi_+ + \beta_- \psi_-^{\epsilon,\alpha}) = 0$ when ϵ is sufficiently small. (Recall the identifications of the normal bundles made at the beginning of Section A.5 that justify writing $\beta_+ \psi_+ + \beta_- \psi_-^{\epsilon,\alpha}$.) The solutions will determine functions $\mathfrak{p}_\epsilon : [-\alpha_0, \alpha_0] \rightarrow \mathbb{R}$ such that

$$(A-6-3) \quad \partial_{N_*^{\epsilon,\alpha}, f_\epsilon}(\beta_+ \psi_+ + \beta_- \psi_-^{\epsilon,\alpha}) = \mathfrak{p}_\epsilon(\alpha)v.$$

Finally, we will solve the equation $\mathfrak{p}_\epsilon(\alpha) = 0$.

In the following lemmas we will repeatedly use Taylor expansions of the form

$$(I) \quad \phi(\mathbf{x}) = \phi(\mathbf{0}) + \sum_i \ell_i(\mathbf{x})x_i,$$

$$(II) \quad \phi(\mathbf{x}) = \phi(\mathbf{0}) + \sum_i \partial_i \phi(\mathbf{0})x_i + \sum_{j,k} q_{j,k}(\mathbf{x})x_j x_k$$

for a smooth function $\phi: \mathbb{R}^n \rightarrow \mathbb{R}$.

Lemma A.6.1 *Over the domain $(-\infty, -T_0] \times S^1$, we can expand*

$$(A-6-4) \quad \bar{\partial}_{N_*^{\epsilon,a}, f_\epsilon}(\beta_+ \psi_+ + \beta_- \psi_-^{\epsilon,a}) = \mathcal{D}_\epsilon \eta_*^{\epsilon,a} + \beta_+(D_+ \psi_+ + \mathcal{L}_+(\psi_+, \psi_-^{\epsilon,a}) + \mathcal{Q}_+(\psi_+, \psi_-^{\epsilon,a})) \\ + \beta_-(D_-^{\epsilon,a} \psi_-^{\epsilon,a} + \mathcal{L}_-(\psi_+, \psi_-^{\epsilon,a}) + \mathcal{Q}_-(\psi_+, \psi_-^{\epsilon,a})),$$

where:

$$(1) \quad D_+ \psi_+ = \partial \psi_+ / \partial s + j_0 \partial \psi_+ / \partial t - \mathbf{H}f(\eta_+) \psi_+.$$

$$(2) \quad D_-^{\epsilon,a} \psi_-^{\epsilon,a} = \partial \psi_-^{\epsilon,a} / \partial s + j_0 \partial \psi_-^{\epsilon,a} / \partial t - \mathbf{H}f_\epsilon(\eta_*^{\epsilon,a}) \psi_-^{\epsilon,a}.$$

(3) $\mathcal{L}_\pm(\psi_+, \psi_-^{\epsilon,a})$ are linear in ψ_+ and $\psi_-^{\epsilon,a}$ with coefficients which are smooth coefficients of ψ_+ and $\psi_-^{\epsilon,a}$, are supported in $[-T_1, -T_0] \times S^1$ and $(-\infty, -T_0 - 1] \times S^1$, respectively, and satisfy

$$(A-6-5) \quad |\mathcal{L}_\pm(\psi_+(x), \psi_-^{\epsilon,a}(x))| < (c_1(a)\epsilon + c_2(b)) \cdot (|\psi_+(x)| + |\psi_-^{\epsilon,a}(x)|),$$

at every point x of the domain, $c_1(a)$ is a constant which depends only on a , $c_2(b)$ depends only on b , and $\lim_{b \rightarrow 0} c_2(b) = 0$.

(4) \mathcal{Q}_\pm are quadratic functions of ψ_+ and $\psi_-^{\epsilon,a}$ with coefficients which are smooth functions of ψ_+ and $\psi_-^{\epsilon,a}$, and there exists $C > 0$ such that

$$(A-6-6) \quad |\mathcal{Q}_\pm(\psi_+(x), \psi_-^{\epsilon,a}(x))| < C (|\psi_+(x)|^2 + |\psi_-^{\epsilon,a}(x)|^2)$$

at every point x of the domain.

(5) $\mathcal{L}_+ = 0$ and $\mathcal{Q}_+ = 0$ for $s \leq -T_1$ and $\mathcal{L}_-, \mathcal{Q}_-$ can be extended smoothly to $\mathcal{L}_- = 0$ and $\mathcal{Q}_- = 0$ for $s \geq -T_0$.

Proof Over the domain $(-\infty, -T_0] \times S^1$, we have

$$\bar{\partial}_{N_*^{\epsilon,a}, f_\epsilon}(\beta_+ \psi_+ + \beta_- \psi_-^{\epsilon,a}) = \mathcal{D}_\epsilon(\eta_*^{\epsilon,a} + \beta_+ \psi_+ + \beta_- \psi_-^{\epsilon,a})$$

by Claim A.1.3. Writing $\eta^{\epsilon,a} = \eta_*^{\epsilon,a} + \beta_+ \psi_+ + \beta_- \psi_-^{\epsilon,a}$ we expand

$$\mathcal{D}_\epsilon \eta^{\epsilon,a} = \frac{\partial}{\partial s}(\eta_*^{\epsilon,a} + \beta_+ \psi_+ + \beta_- \psi_-^{\epsilon,a}) + j_0 \frac{\partial}{\partial t}(\eta_*^{\epsilon,a} + \beta_+ \psi_+ + \beta_- \psi_-^{\epsilon,a}) - \nabla f_\epsilon(\eta_*^{\epsilon,a} + \beta_+ \psi_+ + \beta_- \psi_-^{\epsilon,a}).$$

Using the Taylor expansion of type (II), we write

$$\nabla f_\epsilon(\eta_*^{\epsilon,a} + \beta_+ \psi_+ + \beta_- \psi_-^{\epsilon,a}) = \nabla f_\epsilon(\eta_*^{\epsilon,a}) + \beta_+ \mathbf{H}f_\epsilon(\eta_*^{\epsilon,a}) \psi_+ + \beta_- \mathbf{H}f_\epsilon(\eta_*^{\epsilon,a}) \psi_-^{\epsilon,a} - \mathcal{Q}(\beta_+ \psi_+, \beta_- \psi_-^{\epsilon,a}),$$

where Q is a quadratic function of $\beta_+ \psi_+, \beta_- \psi_-^{\epsilon, \alpha}$ with coefficients which are smooth functions of $\beta_+ \psi_+, \beta_- \psi_-^{\epsilon, \alpha}$. Then

$$\begin{aligned}
 \text{(A-6-7)} \quad \mathcal{D}_\epsilon \eta^{\epsilon, \alpha} &= \left(\frac{\partial \eta_*^{\epsilon, \alpha}}{\partial s} + j_0 \frac{\partial \eta_*^{\epsilon, \alpha}}{\partial t} - \nabla f_\epsilon(\eta_*^{\epsilon, \alpha}) \right) \\
 &+ \beta_+ \left(\frac{\partial \psi_+}{\partial s} + j_0 \frac{\partial \psi_+}{\partial t} - \mathbf{H}f(\eta_+) \psi_+ \right) + \beta_- \left(\frac{\partial \psi_-^{\epsilon, \alpha}}{\partial s} + j_0 \frac{\partial \psi_-^{\epsilon, \alpha}}{\partial t} - \mathbf{H}f_\epsilon(\eta_-^{\epsilon, \alpha}) \psi_-^{\epsilon, \alpha} \right) \\
 &+ \beta_+ (\mathbf{H}f(\eta_+) - \mathbf{H}f_\epsilon(\eta_*^{\epsilon, \alpha})) \psi_+ + \beta_- (\mathbf{H}f_\epsilon(\eta_-^{\epsilon, \alpha}) - \mathbf{H}f_\epsilon(\eta_*^{\epsilon, \alpha})) \psi_-^{\epsilon, \alpha} \\
 &+ \beta'_+(s) \psi_+ + \beta'_-(s) \psi_-^{\epsilon, \alpha} \\
 &+ Q(\beta_+ \psi_+, \beta_- \psi_-^{\epsilon, \alpha}).
 \end{aligned}$$

The right-hand side of the first line is $\mathcal{D}_\epsilon \eta_*$ and the second line is $\beta_+ D_+ \psi_+ + \beta_- D_-^{\epsilon, \alpha} \psi_-^{\epsilon, \alpha}$. Let us define $g(y, \theta) = \phi(y) \bar{g}_N(\theta)$. We write

$$\text{(A-6-8)} \quad c_1 = |\mathbf{H}g|_{C^0} \quad \text{and} \quad c_2(b) = \max\{|\beta'_+|_{C^0}, |\beta'_-|_{C^0}\}.$$

Using the fact that $\eta_*^{\epsilon, \alpha}, \eta_+$ and $\eta_-^{\epsilon, \alpha}$ take values in A_a , where $\mathbf{H}f$ is constant, for $s \leq -T_0$, the terms of the third and fourth lines can be bounded as follows:

$$\begin{aligned}
 &|\beta'_+(s) \psi_+(x) + \beta'_-(s) \psi_-^{\epsilon, \alpha}(x)| \leq c_2(b) (|\psi_+(x)| + |\psi_-^{\epsilon, \alpha}(x)|) \\
 \text{(A-6-9)} \quad &|\beta_+ (\mathbf{H}f(\eta_+) - \mathbf{H}f_\epsilon(\eta_*^{\epsilon, \alpha})) \psi_+(x)| \leq \epsilon c_1 \beta_+ |\psi_+(x)|, \\
 &|\beta_- (\mathbf{H}f_\epsilon(\eta_-^{\epsilon, \alpha}) - \mathbf{H}f_\epsilon(\eta_*^{\epsilon, \alpha})) \psi_-^{\epsilon, \alpha}(x)| \leq 2\epsilon c_1 \beta_- |\psi_-^{\epsilon, \alpha}(x)|.
 \end{aligned}$$

We then set

$$\text{(A-6-10)} \quad \mathcal{L}_+^{(1)}(\psi_+, \psi_-^{\epsilon, \alpha}) = (\mathbf{H}f(\eta_+) - \mathbf{H}f_\epsilon(\eta_*^{\epsilon, \alpha})) \psi_+ + (\beta'_+(s) \psi_+ + \beta'_-(s) \psi_-^{\epsilon, \alpha}),$$

$$\text{(A-6-11)} \quad \mathcal{L}_-^{(1)}(\psi_+, \psi_-^{\epsilon, \alpha}) = (\mathbf{H}f_\epsilon(\eta_-^{\epsilon, \alpha}) - \mathbf{H}f_\epsilon(\eta_*^{\epsilon, \alpha})) \psi_-^{\epsilon, \alpha} + (\beta'_+(s) \psi_+ + \beta'_-(s) \psi_-^{\epsilon, \alpha}),$$

and $\beta_\pm \mathcal{L}_\pm^{(1)}(\psi_+, \psi_-^{\epsilon, \alpha})$ satisfies inequality (A-6-5). The terms $\mathcal{L}_+^{(1)}$ and $\mathcal{L}_-^{(1)}$ are not necessarily supported in $[-T_1, -T_0] \times S^1$ and $(-\infty, -T_0 - 1] \times S^1$, respectively, and therefore we rearrange

$$\beta_+ \mathcal{L}_+^{(1)} + \beta_- \mathcal{L}_-^{(1)} = \beta_+ (\beta_+ + \beta_-)^2 \mathcal{L}_+^{(1)} + \beta_- (\beta_+ + \beta_-)^2 \mathcal{L}_-^{(1)} = \beta_+ \mathcal{L}_+(\psi_+, \psi_-^{\epsilon, \alpha}) + \beta_- \mathcal{L}_-(\psi_+, \psi_-^{\epsilon, \alpha}),$$

where

$$\begin{aligned}
 \text{(A-6-12)} \quad \mathcal{L}_+(\psi_+, \psi_-^{\epsilon, \alpha}) &= \beta_+^2 \mathcal{L}_+^{(1)} + 2\beta_+ \beta_- \mathcal{L}_+^{(1)} + \beta_+ \beta_- \mathcal{L}_-^{(1)}, \\
 \mathcal{L}_-(\psi_+, \psi_-^{\epsilon, \alpha}) &= \beta_+ \beta_- \mathcal{L}_+^{(1)} + 2\beta_+ \beta_- \mathcal{L}_-^{(1)} + \beta_-^2 \mathcal{L}_-^{(1)},
 \end{aligned}$$

the same inequalities hold for $\mathcal{L}_\pm^{(1)}$ and \mathcal{L}_\pm and (5) holds for \mathcal{L}_\pm . However, the constants c_1 and c_2 in the statement are closely related to the constants c_1 and c_2 in (A-6-9) but not exactly the same. Finally we can decompose and rearrange so that

$$Q(\beta_+ \psi_+, \beta_- \psi_-^{\epsilon, \alpha}) = \beta_+ Q_+(\psi_+, \psi_-^{\epsilon, \alpha}) + \beta_- Q_-(\psi_+, \psi_-^{\epsilon, \alpha}),$$

inequality (A-6-6) holds, and (5) holds for Q_\pm . □

In particular, equation (A-6-3) is satisfied on $(-\infty, -T_0] \times S^1$ if the following pair of equations hold:

$$(A-6-13) \quad \mathcal{D}_\epsilon \eta_*^{\epsilon, \alpha} + D_+ \psi_+ + \mathcal{L}_+(\psi_+, \psi_-^{\epsilon, \alpha}) + \mathcal{Q}_+(\psi_+, \psi_-^{\epsilon, \alpha}) = \mathfrak{p}_\epsilon(\mathfrak{a})\nu,$$

$$(A-6-14) \quad \mathcal{D}_\epsilon \eta_*^{\epsilon, \alpha} + D_-^{\epsilon, \alpha} \psi_-^{\epsilon, \alpha} + \mathcal{L}_-(\psi_+, \psi_-^{\epsilon, \alpha}) + \mathcal{Q}_-(\psi_+, \psi_-^{\epsilon, \alpha}) = \mathfrak{a}\nu.$$

The term $\mathfrak{a}\nu$ in the second equation is legitimate because ν is supported on $[-T_0 - 1, -T_0] \times S^1$ where $\beta_- = 0$. It was chosen to make $\mathcal{D}_\epsilon \eta_*^{\epsilon, \alpha} - \mathfrak{a}\nu$ small (independent of \mathfrak{a}) in the sense of estimate (A-7-2).

Remark A.6.2 More in line with the obstruction gluing of [Hutchings and Taubes 2007], equation (A-6-3) can be split into

$$\begin{aligned} \bar{D}_+^\delta \psi_+ + \Pi(\mathcal{D}_\epsilon \eta_*^{\epsilon, \alpha} + \mathcal{L}_+(\psi_+, \psi_-^{\epsilon, \alpha}) + \mathcal{Q}_+(\psi_+, \psi_-^{\epsilon, \alpha})) &= 0, \\ (1 - \Pi)(\mathcal{D}_\epsilon \eta_*^{\epsilon, \alpha} + \mathcal{L}_+(\psi_+, \psi_-^{\epsilon, \alpha}) + \mathcal{Q}_+(\psi_+, \psi_-^{\epsilon, \alpha})) &= \mathfrak{p}_\epsilon(\mathfrak{a})\nu, \\ D_-^{\epsilon, \alpha, \delta} \psi_-^{\epsilon, \alpha} + (\mathcal{D}_\epsilon \eta_*^{\epsilon, \alpha} - \mathfrak{a}\nu) + \mathcal{L}_-(\psi_+, \psi_-^{\epsilon, \alpha}) + \mathcal{Q}_-(\psi_+, \psi_-^{\epsilon, \alpha}) &= 0, \end{aligned}$$

where $\Pi: \mathcal{H}_{0, g_\delta}(\dot{F}, \Lambda^{0,1} N_+) \rightarrow \mathcal{H}'_{+, \delta}$ is the projection from Section A.5.4 and the second equation is always satisfied.

We say that $\mathcal{Q}(\psi_+)$ is *type 1 quadratic* if it can be written as

$$\mathcal{Q}(\psi_+) = P(\psi_+) + Q(\psi_+) \cdot \nabla \psi_+,$$

where there exists a constant $C > 0$ such that $|P(\psi_+(x))| < C|\psi_+(x)|^2$ and $|Q(\psi_+(x))| \leq C|\psi_+(x)|$ at every point x of the domain.

Remark A.6.3 The reason for the different treatment of the term $\tilde{\partial}_\theta$ compared to the other infinitesimal deformations of the map u_+ is that the term $\beta'(s)\tilde{\partial}_\theta$ which would appear in (A-6-9) cannot be made small in $\mathcal{H}_{0, g_\delta}(\dot{F}, \Lambda^{0,1} N_+)$ by choosing b and ϵ small.

Lemma A.6.4 Over the domain $\dot{F} - (-\infty, -T_0) \times S^1$, we can expand

$$(A-6-15) \quad \bar{\partial}_{N_*^{\epsilon, \alpha}, f_\epsilon}(\beta_- \psi_-^{\epsilon, \alpha} + \beta_+ \psi_+) = D_+ \psi_+ + \mathcal{Q}(\psi_+),$$

where $\mathcal{Q}(\psi_+)$ is type 1 quadratic, and (A-6-4) and (A-6-15) agree along $s = -T_0$.

Proof Over the domain $\dot{F} - (-\infty, -T_0) \times S^1$, $\beta_+ = 1$, $\beta_- = 0$, $u_*^{\epsilon, \alpha} = u_+$ and $u^{\epsilon, \alpha} = \exp_{u_*^{\epsilon, \alpha}} \psi_+ = \exp_{u_+} \psi_+$. Hence ψ_+ satisfies (A-5-4) with ψ_+ instead of ξ and $(\sigma, \tau) = (s, t)$. Equation (A-6-15) then follows from (A-5-4) together with (A-5-5) by applying the Taylor expansion of type (I) to a , b and X . The agreement of (A-6-4) and (A-6-15) along $s = -T_0$ is a consequence of the definition of \exp_{u_+} for $s \leq -T_0$. \square

A.7 Proof of Theorem A.2.5

In this subsection and the next, we use the convention that constants such as C , c_1 , $c_2(b)$ may change from line to line when making estimates. Recall that

$$(A-7-1) \quad \lambda := \min(\lambda_1, |\lambda_{-1}|) > 5\delta.$$

Lemma A.7.1 *There exists a constant $C > 0$ such that*

$$(A-7-2) \quad \|\mathcal{D}_\epsilon \eta_*^{\epsilon, \alpha} - \alpha v\|_{g_\delta} \leq C(e^{(\delta-\lambda)T_2(\epsilon)} + \epsilon T_1 e^{\delta T_1}).$$

Proof By Lemma A.4.4, it suffices to estimate $\|\mathcal{D}_\epsilon \eta_*^{\epsilon, \alpha}\|_{g_\delta}$ on $[-T_2, -T_2 + 1] \times S^1$ and $[-T_1, -T_0] \times S^1$. We will use the simple fact that the Morrey norm of a continuous function on a compact domain is dominated by the C^0 norm.

First we estimate $\mathcal{D}_\epsilon \eta_*^{\epsilon, \alpha} - \alpha v$ on $[-T_2, -T_2 + 1] \times S^1$, where $v = 0$. By the definition of $\eta_*^{\epsilon, \alpha}$ (equation (A-4-4)) and (J_{f_ϵ}) , and with the understanding that all maps and norms are restricted to $[-T_2, -T_2 + 1] \times S^1$ (on which $f_\epsilon(y, \theta) = \frac{1}{2}y^2 + \epsilon \bar{g}_N(\theta)$, $\nabla f_\epsilon = y \partial_y + \epsilon \partial_\theta$ and \mathcal{D}_0 is linear), we have

$$\mathcal{D}_\epsilon(\eta_*^{\epsilon, \alpha}) = \mathcal{D}_\epsilon(\eta_*^{\epsilon, \alpha}) + \beta(s + T_2)\mathcal{D}_0(\eta_+) + \beta'(s + T_2)\eta_+ = \beta'(s + T_2)\eta_+$$

and therefore

$$(A-7-3) \quad \|\mathcal{D}_\epsilon \eta_*^{\epsilon, \alpha}\|_{g_\delta} \leq C \left\| \sum_{i=1}^\infty c_i e^{\lambda_i s} g_i(t) \right\|_{g_\delta} \leq C e^{(\delta-\lambda)(T_2(\epsilon)-T_0)} \leq C e^{(\delta-\lambda)T_2(\epsilon)}.$$

Next we estimate $\mathcal{D}_\epsilon \eta_*^{\epsilon, \alpha} - \alpha v$ on $[-T_1, -T_0] \times S^1$. The restriction of $\eta_*^{\epsilon, \alpha}$ to $[-T_1, -T_0] \times S^1$ takes values in the region where ∇f_ϵ no longer has the simple expression which leads to (J_{f_ϵ}) , but from (A-1-2) we obtain

$$(A-7-4) \quad \mathcal{D}_\epsilon(\eta_*^{\epsilon, \alpha}) = \mathcal{D}_0(\eta_*^{\epsilon, \alpha}) - \epsilon \nabla g(\eta_*^{\epsilon, \alpha}),$$

where $g(y, \theta) = \phi(y)\bar{g}_N(\theta)$. By the definition of $\eta_*^{\epsilon, \alpha}$ and v , equation (A-7-4), and with the understanding that all maps and norms are restricted to $[-T_1, -T_0] \times S^1$, we have

$$(A-7-5) \quad \|\mathcal{D}_\epsilon \eta_*^{\epsilon, \alpha} + \beta'(-s - T_0) \cdot (0, \alpha)\|_{g_\delta} \leq \left\| \frac{\partial}{\partial s} \left(\beta \left(\frac{s + T_0}{-T_1 + T_0} \right) (0, \epsilon(s + T_1)) \right) \right\|_{g_\delta} + \epsilon \|\nabla g(\eta_*^{\epsilon, \alpha})\|_{g_\delta} \leq C \epsilon T_1 e^{\delta T_1}.$$

Estimates (A-7-3) and (A-7-5) imply estimate (A-7-2). □

Remark A.7.2 Since $\mathcal{D}_\epsilon \eta_*^{\epsilon, \alpha} + \beta'(-s - T_0) \cdot (0, \alpha)$ is supported in $(-\infty, -T_0] \times S^1$, where g_δ and h_δ coincide, we can also regard it as an element of $\mathcal{H}'_{-, \delta}$ with norm

$$\|\mathcal{D}_\epsilon \eta_*^{\epsilon, \alpha} + \beta'(-s - T_0) \cdot (0, \alpha)\|_{h_\delta} = \|\mathcal{D}_\epsilon \eta_*^{\epsilon, \alpha} + \beta'(-s - T_0) \cdot (0, \alpha)\|_{g_\delta}.$$

Let $(\bar{D}_+^\delta)^{-1}$ be the inverse of \bar{D}_+^δ , viewed as a map to the orthogonal complement $\mathcal{H}_{+, \delta}^\perp$ of $\ker \bar{D}_+^\delta$, and let $(D_-^{\epsilon, \alpha, \delta})^{-1}$ be the inverse of $D_-^{\epsilon, \alpha, \delta}$. Recall that the norm of $(D_-^{\epsilon, \alpha, \delta})^{-1}$ is uniformly bounded in ϵ and α by Lemma A.5.4. Let

$$(A-7-6) \quad \mathcal{B}_+ = \text{closed ball of radius } \tilde{\epsilon} \text{ in } \mathcal{H}_{+, \delta}^\perp,$$

$$(A-7-7) \quad \mathcal{B}_- = \text{closed ball of radius } \tilde{\epsilon} \text{ in } \mathcal{H}_{-, \delta},$$

where the small constant $\tilde{\epsilon} > 0$ is to be determined more precisely later.

Let $\mathcal{I}_+ : \mathcal{B}_+ \times \mathcal{B}_- \rightarrow \mathcal{H}_{+, \delta}^\perp$ and $\mathcal{I}_- : \mathcal{B}_+ \times \mathcal{B}_- \rightarrow \mathcal{H}_{-, \delta}$ be maps given by

$$(A-7-8) \quad \mathcal{I}_+(\psi_+, \psi_-^{\epsilon, \alpha}) = -(\bar{D}_+^\delta)^{-1} \Pi(\mathcal{F}_+(\psi_+, \psi_-^{\epsilon, \alpha})),$$

$$(A-7-9) \quad \mathcal{I}_-(\psi_+, \psi_-^{\epsilon, \alpha}) = -(D_-^{\epsilon, \alpha, \delta})^{-1} (\mathcal{F}_-(\psi_+, \psi_-^{\epsilon, \alpha})),$$

where

$$\mathcal{F}_+(\psi_+, \psi_-^{\epsilon, \alpha}) := \begin{cases} \mathcal{D}_\epsilon \eta_*^{\epsilon, \alpha} + \mathcal{L}_+(\psi_+, \psi_-^{\epsilon, \alpha}) + \mathcal{Q}_+(\psi_+, \psi_-^{\epsilon, \alpha}) & \text{on } (-\infty, -T_0] \times S^1, \\ \mathcal{Q}(\psi_+) & \text{on } \dot{F} - (-\infty, -T_0] \times S^1, \end{cases}$$

$$\mathcal{F}_-(\psi_+, \psi_-^{\epsilon, \alpha}) := \begin{cases} \mathcal{D}_\epsilon \eta_*^{\epsilon, \alpha} - \alpha \nu + \mathcal{L}_-(\psi_+, \psi_-^{\epsilon, \alpha}) + \mathcal{Q}_-(\psi_+, \psi_-^{\epsilon, \alpha}) & \text{on } (-\infty, -T_0] \times S^1, \\ 0 & \text{on } [-T_0, \infty) \times S^1. \end{cases}$$

Here the definitions of $\mathcal{F}_+(\psi_+, \psi_-^{\epsilon, \alpha})$ agree on $\{-T_0\} \times S^1$ by Lemma A.6.4 and the definitions of $\mathcal{F}_-(\psi_+, \psi_-^{\epsilon, \alpha})$ agree on $\{-T_0\} \times S^1$ by Lemmas A.6.1(5) and A.4.4.

Solving (A-6-13) and (A-6-14) is then equivalent to solving the equations

$$(A-7-10) \quad \psi_+ = \mathcal{I}_+(\psi_+, \psi_-^{\epsilon, \alpha}),$$

$$(A-7-11) \quad \psi_-^{\epsilon, \alpha} = \mathcal{I}_-(\psi_+, \psi_-^{\epsilon, \alpha}).$$

The following two lemmas provide the necessary estimates to apply the contraction mapping theorem to (A-7-10) and (A-7-11).

Notation A.7.3 We will sometimes write

$$(A-7-12) \quad \|\cdot\|_{*, \delta} := \|\cdot\|_{*, g_\delta} \text{ or } \|\cdot\|_{*, h_\delta},$$

depending on the context.

Lemma A.7.4 If $(\psi_+, \psi_-^{\epsilon, \alpha}) \in \mathcal{B}_+ \times \mathcal{B}_-$, then

$$(A-7-13) \quad \|\mathcal{I}_\pm(\psi_+, \psi_-^{\epsilon, \alpha})\|_{*, \delta} \leq C(e^{(\delta-\lambda)T_2(\epsilon)} + \epsilon T_1(b)e^{\delta T_1(b)}) + (c_1\epsilon + c_2(b))(\|\psi_+\|_{*, g_\delta} + \|\psi_-^{\epsilon, \alpha}\|_{*, h_\delta}) + C(\|\psi_+\|_{*, g_\delta}^2 + \|\psi_-^{\epsilon, \alpha}\|_{*, h_\delta}^2),$$

where c_1 is constant and $\lim_{b \rightarrow 0} c_2(b) = 0$.

Proof We will carry out estimates on the $(-\infty, -T_0] \times S^1$ portion, with the understanding that the norms are restricted to $(-\infty, -T_0] \times S^1$, where $g_\delta = h_\delta$. (This justifies the use of the weight g_δ throughout the proof, even where one should expect h_δ .) The estimates on the $\dot{F} - (-\infty, -T_0] \times S^1$ portion, which involve only \mathcal{I}_+ and ψ_+ , are straightforward and are left to the reader.

By the definitions of $\mathcal{I}_\pm(\psi_+, \psi_-^{\epsilon, \alpha})$,

$$(A-7-14) \quad \|\mathcal{I}_\pm(\psi_+, \psi_-^{\epsilon, \alpha})\|_{*, g_\delta} \leq C(\|\mathcal{D}_\epsilon \eta_* - \alpha \nu\|_{g_\delta} + \|\mathcal{L}_\pm(\psi_+, \psi_-^{\epsilon, \alpha})\|_{g_\delta} + \|\mathcal{Q}_\pm(\psi_+, \psi_-^{\epsilon, \alpha})\|_{g_\delta}),$$

since $(\bar{D}_+^\delta)^{-1}$ is bounded, $(D_-^{\epsilon, \alpha, \delta})^{-1}$ are uniformly bounded, and $\Pi(\mathcal{D}_\epsilon \eta_*) = \Pi(\mathcal{D}_\epsilon \eta_* - \alpha \nu)$.

We will make frequent use of the estimate

$$(A-7-15) \quad |\zeta|_{C^0} \leq C \|\zeta\|_{*,g_\delta},$$

which follows from Lemma A.5.1 and $\|\zeta\|_* \leq \|\zeta\|_{*,g_\delta}$ since $g_\delta > 1$.

By (A-7-2),

$$(A-7-16) \quad \|\mathcal{D}_\epsilon \eta_*^{\epsilon,\alpha} - \mathbf{av}\|_{g_\delta} \leq C(e^{(\delta-\lambda)T_2(\epsilon)} + \epsilon T_1 e^{\delta T_1}).$$

Next, since \mathcal{L}_\pm satisfies estimate (A-6-5),

$$(A-7-17) \quad \|\mathcal{L}_\pm(\psi_+, \psi_-^{\epsilon,\alpha})\|_{g_\delta} \leq (c_1\epsilon + c_2(b))(\|\psi_+\|_{g_\delta} + \|\psi_-^{\epsilon,\alpha}\|_{g_\delta}).$$

Finally, since \mathcal{Q}_\pm satisfies estimate (A-6-6),

$$(A-7-18) \quad \begin{aligned} \|\mathcal{Q}_\pm(\psi_+, \psi_-^{\epsilon,\alpha})\|_{g_\delta} &\leq C(|\psi_+|_{C^0} \|\psi_+\|_{g_\delta} + |\psi_-^{\epsilon,\alpha}|_{C^0} \|\psi_-^{\epsilon,\alpha}\|_{g_\delta}) \\ &\leq C(\|\psi_+\|_{*,g_\delta} \|\psi_+\|_{g_\delta} + \|\psi_-^{\epsilon,\alpha}\|_{*,g_\delta} \|\psi_-^{\epsilon,\alpha}\|_{g_\delta}), \end{aligned}$$

using estimate (A-7-15). We explain the first line of estimate (A-7-18). The first term of the Morrey norm is the weighted L^2 norm, and we can bound

$$\begin{aligned} \int_{\dot{F}} g_\delta^2 |\mathcal{Q}_+(\psi_+, \psi_-^{\epsilon,\alpha})|^2 &\leq \int_{\dot{F}} g_\delta^2 C^2 (|\psi_+|^4 + |\psi_-^{\epsilon,\alpha}|^4) \\ &\leq C^2 |\psi_+|_{C^0}^2 \int_{\dot{F}} g_\delta^2 |\psi_+|^2 + C^2 |\psi_-^{\epsilon,\alpha}|_{C^0}^2 \int_{\dot{F}} g_\delta^2 |\psi_-^{\epsilon,\alpha}|^2, \\ \left(\int_{\dot{F}} g_\delta^2 |\mathcal{Q}_+(\psi_+, \psi_-^{\epsilon,\alpha})|^2 \right)^{1/2} &\leq C |\psi_+|_{C^0} \left(\int_{\dot{F}} g_\delta^2 |\psi_+|^2 \right)^{1/2} + C |\psi_-^{\epsilon,\alpha}|_{C^0} \left(\int_{\dot{F}} g_\delta^2 |\psi_-^{\epsilon,\alpha}|^2 \right)^{1/2}. \end{aligned}$$

The bound for the second term of the Morrey norm is similar, since it is of L^2 type.

Estimates (A-7-14) and (A-7-16)–(A-7-18), together with estimate (A-7-14), give estimate (A-7-13). Here we are using the trivial observation $\|\cdot\|_{g_\delta} \leq \|\cdot\|_{*,g_\delta}$. □

Lemma A.7.5 *If $(\psi_+, \psi_-^{\epsilon,\alpha}), (\bar{\psi}_+, \bar{\psi}_-^{\epsilon,\alpha}) \in \mathcal{B}_+ \times \mathcal{B}_-$, then*

$$(A-7-19) \quad \|\mathcal{I}_\pm(\psi_+, \psi_-^{\epsilon,\alpha}) - \mathcal{I}_\pm(\bar{\psi}_+, \bar{\psi}_-^{\epsilon,\alpha})\|_{*,\delta} \leq (c_1\epsilon + c_2(b) + C\tilde{\epsilon})(\|\psi_+ - \bar{\psi}_+\|_{*,g_\delta} + \|\psi_-^{\epsilon,\alpha} - \bar{\psi}_-^{\epsilon,\alpha}\|_{*,h_\delta}).$$

Proof Again we carry out the estimate on the $(-\infty, -T_0] \times S^1$ portion, with the understanding that the norms are restricted to $(-\infty, -T_0] \times S^1$, and leave the estimate on the $\dot{F} - (-\infty, -T_0] \times S^1$ portion to the reader.

In the following equation \mathcal{D}_\pm stands for either \bar{D}_\pm^δ or $D_\pm^{\epsilon,\alpha,\delta}$. We have

$$\begin{aligned} \mathcal{I}_\pm(\psi_+, \psi_-^{\epsilon,\alpha}) - \mathcal{I}_\pm(\bar{\psi}_+, \bar{\psi}_-^{\epsilon,\alpha}) \\ = -\mathcal{D}_\pm^{-1}((\mathcal{L}_\pm(\psi_+, \psi_-^{\epsilon,\alpha}) - \mathcal{L}_\pm(\bar{\psi}_+, \bar{\psi}_-^{\epsilon,\alpha})) + (\mathcal{Q}_\pm(\psi_+, \psi_-^{\epsilon,\alpha}) - \mathcal{Q}_\pm(\bar{\psi}_+, \bar{\psi}_-^{\epsilon,\alpha}))). \end{aligned}$$

By (A-6-10), (A-6-11), (A-6-12), as well as an analog of estimate (A-6-5), we have

$$\|\mathcal{L}_\pm(\psi_+, \psi_-^{\epsilon,\alpha}) - \mathcal{L}_\pm(\bar{\psi}_+, \bar{\psi}_-^{\epsilon,\alpha})\|_{g_\delta} \leq (c_1\epsilon + c_2(b))(\|\psi_+ - \bar{\psi}_+\|_{g_\delta} + \|\psi_-^{\epsilon,\alpha} - \bar{\psi}_-^{\epsilon,\alpha}\|_{g_\delta}).$$

By Lemma A.6.1(4), $\mathcal{Q}_\pm(\psi_+, \psi_-^{\epsilon, \alpha})$ is a quadratic function of $\psi_+, \psi_-^{\epsilon, \alpha}$ with uniformly bounded coefficients which are smooth functions of $\psi_+, \psi_-^{\epsilon, \alpha}$. Therefore

$$\begin{aligned} & \|\mathcal{Q}_\pm(\psi_+, \psi_-^{\epsilon, \alpha}) - \mathcal{Q}_\pm(\bar{\psi}_+, \bar{\psi}_-^{\epsilon, \alpha})\|_{g_\delta} \\ & \leq C(|\psi_+ - \bar{\psi}_+|_{C^0} + |\psi_-^{\epsilon, \alpha} - \bar{\psi}_-^{\epsilon, \alpha}|_{C^0})(\|\psi_+\|_{g_\delta} + \|\psi_-^{\epsilon, \alpha}\|_{g_\delta} + \|\bar{\psi}_+\|_{g_\delta} + \|\bar{\psi}_-^{\epsilon, \alpha}\|_{g_\delta}). \end{aligned}$$

Combining the two estimates and using (A-7-15) and $\|\cdot\|_{g_\delta} \leq \|\cdot\|_{*, g_\delta}$, we obtain estimate (A-7-19). \square

Proposition A.7.6 *There exists $\tilde{\epsilon} > 0$ sufficiently small that, for all b, \mathfrak{a}_0 and $\epsilon_0 = \epsilon_0(\mathfrak{a}_0, b)$ sufficiently small (in particular satisfying (\dagger_2)) and for all $(\mathfrak{a}, \epsilon) \in [-\mathfrak{a}_0, \mathfrak{a}_0] \times (0, \epsilon_0]$, there exists a unique $(\psi_+, \psi_-^{\epsilon, \alpha}) \in \mathcal{B}_+ \times \mathcal{B}_-$ satisfying*

$$(A-7-20) \quad \mathcal{I}_+(\psi_+, \psi_-^{\epsilon, \alpha}) = \psi_+, \quad \mathcal{I}_-(\psi_+, \psi_-^{\epsilon, \alpha}) = \psi_-^{\epsilon, \alpha}.$$

Moreover, the solutions of (A-7-20) satisfy the estimate

$$(A-7-21) \quad \|\psi_+\|_{*, g_\delta} + \|\psi_-^{\epsilon, \alpha}\|_{*, h_\delta} \leq C(e^{(\delta-\lambda)T_2(\epsilon)} + \epsilon T_1(b))e^{\delta T_1(b)}.$$

Proof Let $\mathcal{I} = (\mathcal{I}_+, \mathcal{I}_-): \mathcal{B}_+ \times \mathcal{B}_- \rightarrow \mathcal{H}_{+, \delta}^\perp \times \mathcal{H}_{-, \delta}$. Lemmas A.7.4 and A.7.5 imply that, for sufficiently small $\tilde{\epsilon}$, there are sufficiently small constants b, \mathfrak{a}_0 and $\epsilon_0 = \epsilon_0(\mathfrak{a}_0)$ such that, for all $(\mathfrak{a}, \epsilon) \in [-\mathfrak{a}_0, \mathfrak{a}_0] \times (0, \epsilon_0]$, we have estimates

$$(A-7-22) \quad \|\mathcal{I}_\pm(\psi_+, \psi_-^{\epsilon, \alpha})\|_{*, \delta} \leq C(e^{(\delta-\lambda)T_2(\epsilon)} + \epsilon T_1(b))e^{\delta T_1(b)} + \frac{1}{4}(\|\psi_+\|_{*, g_\delta} + \|\psi_-^{\epsilon, \alpha}\|_{*, h_\delta}),$$

$$(A-7-23) \quad \|\mathcal{I}_\pm(\psi_+, \psi_-^{\epsilon, \alpha}) - \mathcal{I}_\pm(\bar{\psi}_+, \bar{\psi}_-^{\epsilon, \alpha})\|_{*, \delta} \leq \frac{1}{4}(\|\psi_+ - \bar{\psi}_+\|_{*, g_\delta} + \|\psi_-^{\epsilon, \alpha} - \bar{\psi}_-^{\epsilon, \alpha}\|_{*, h_\delta})$$

and \mathcal{I} is a contraction of $\mathcal{B}_+ \times \mathcal{B}_-$ (for the metric induced by the sum of the norms). Then the contraction mapping theorem implies that there is a unique pair $(\psi_+, \psi_-^{\epsilon, \alpha}) \in \mathcal{B}_+ \times \mathcal{B}_-$ such that $\mathcal{I}(\psi_+, \psi_-^{\epsilon, \alpha}) = (\psi_+, \psi_-^{\epsilon, \alpha})$. Finally, estimate (A-7-21) is obtained by plugging (A-7-20) in (A-7-22), rearranging the terms, and renaming the constant C . \square

Proposition A.7.6 produces, provided b, \mathfrak{a}_0 and $\epsilon_0 = \epsilon_0(\mathfrak{a}_0)$ are sufficiently small, a map

$$u^{\epsilon, \alpha} = \exp_{u_*^{\epsilon, \alpha}}(\beta_+ \psi_+ + \beta_- \psi_-^{\epsilon, \alpha})$$

for all $(\mathfrak{a}, \epsilon) \in [-\mathfrak{a}_0, \mathfrak{a}_0] \times (0, \epsilon_0]$ and a continuous function $\mathfrak{p}_\epsilon: [-\mathfrak{a}_0, \mathfrak{a}_0] \rightarrow \mathbb{R}$ such that $\bar{\partial}_{J_{f_\epsilon}} u^{\epsilon, \alpha} = \mathfrak{p}_\epsilon(\mathfrak{a})v$ for all $\epsilon \in (0, \epsilon_0]$. Moreover, by (A-7-2) and (A-7-21),

$$\begin{aligned} |\mathfrak{p}_\epsilon(\mathfrak{a}) - \mathfrak{a}| & \leq C(\|\mathfrak{p}_\epsilon(\mathfrak{a})v - \mathfrak{a}v\|_{g_\delta}) \leq C(\|\bar{\partial}_{J_{f_\epsilon}} u^{\epsilon, \alpha} - \bar{\partial}_{J_{f_\epsilon}} u_*^{\epsilon, \alpha}\|_{g_\delta} + \|\bar{\partial}_{J_{f_\epsilon}} u_*^{\epsilon, \alpha} - \mathfrak{a}v\|_{g_\delta}) \\ & \leq C(\|\psi_+\|_{*, g_\delta} + \|\psi_-^{\epsilon, \alpha}\|_{*, h_\delta}) + C(\|\mathcal{D}_\epsilon \eta_*^{\epsilon, \alpha} - \mathfrak{a}v\|_{g_\delta}) \\ & \leq C(e^{(\delta-\lambda)T_2(\epsilon)} + \epsilon T_1(b))e^{\delta T_1(b)}. \end{aligned}$$

In order to bound $\|\bar{\partial}_{J_{f_\epsilon}} u^{\epsilon, \alpha} - \bar{\partial}_{J_{f_\epsilon}} u_*^{\epsilon, \alpha}\|_{g_\delta}$ we used Lemmas A.6.1 and A.6.4 and (A-7-21).

If ϵ_0 is sufficiently small, then $\mathfrak{p}_\epsilon(-\mathfrak{a}_0) < 0$ and $\mathfrak{p}_\epsilon(\mathfrak{a}_0) > 0$, and therefore \mathfrak{p}_ϵ has an odd number of zeros in the interval $[-\mathfrak{a}_0, \mathfrak{a}_0]$.

A.8 Proof of Theorem A.2.6

From now on, until the end of the appendix, we fix a b such that Proposition A.7.6 holds. *Therefore, from now on, b and $T_1(b)$ are to be considered constants.*

Remark A.8.1 In [Yao 2022b], the strategy for the proof of Theorem A.2.6 is slightly different: one can actually differentiate the 1-parameter family of functions $\psi_{-}^{\epsilon, a}$ with respect to a to show that $p_{\epsilon}(a)$ is C^1 -close to a and hence that the zero is unique.

Arguing by contradiction, suppose there are sequences $\{\kappa_i\}_{i=1}^{\infty}$, $\{\epsilon_i\}_{i=1}^{\infty}$, $\{u^{\epsilon_i}\}_{i=1}^{\infty}$ and $\{v^{\epsilon_i}\}_{i=1}^{\infty}$ (with a , b , c and ϵ' small but fixed) such that

- (1) $\kappa_i \rightarrow 0$ and $\epsilon_i \rightarrow 0$,
- (2) $u^{\epsilon_i}, v^{\epsilon_i} : (\dot{F}, j_i) \rightarrow \mathbb{R} \times M$ are $\bar{\partial}_{J_{f_{\epsilon_i}}}$ -holomorphic and are not related by \mathbb{R} -translations in the target (and possibly the domain), and
- (3) u^{ϵ_i} and v^{ϵ_i} are κ_i -close to breaking into u_+ and a cylinder over $\mathcal{T}_0^{\epsilon_i}$.

After translating the u^{ϵ_i} and v^{ϵ_i} in the target and possibly in the domain, we can find $T_1 > 0$ such that $u^{\epsilon_i}|_{(-\infty, -T_1]}$ and $v^{\epsilon_i}|_{(-\infty, -T_1]}$ have image in $\mathbb{R} \times [-b - \epsilon', b + \epsilon'] \times T^2$ and $u^{\epsilon_i}|_{s=-T_1}$ and $v^{\epsilon_i}|_{s=-T_1}$ have image in $\mathbb{R} \times [b, b + \epsilon'] \times T^2$. On $(-\infty, -T_1] \times S^1$ we write

$$u^{\epsilon_i}(s, t) = (s, t, \eta^{u^{\epsilon_i}}(s, t)) \quad \text{and} \quad v^{\epsilon_i}(s, t) = (s, t, \eta^{v^{\epsilon_i}}(s, t)).$$

Recall that $\eta^{u^{\epsilon_i}}$ and $\eta^{v^{\epsilon_i}}$ satisfy (A-1-3), which we repeat here:

$$\frac{\partial \eta}{\partial s} + j_0 \frac{\partial \eta}{\partial t} - \nabla f_{\epsilon}(\eta) = 0.$$

If we restrict $\eta^{u^{\epsilon_i}}$ and $\eta^{v^{\epsilon_i}}$ to any cylinder $[-T_1'(\epsilon_i), -T_1] \times S^1$ such that their images are in B , then (A-1-3) specializes to $(J_{f_{\epsilon_i}})$ and their difference $\zeta^{\epsilon_i}(s, t) = \eta^{v^{\epsilon_i}}(s, t) - \eta^{u^{\epsilon_i}}(s, t)$ satisfies the linear equation (J_f) :

$$(A-8-1) \quad \frac{\partial \zeta^{\epsilon_i}}{\partial s} - A \zeta^{\epsilon_i} = 0.$$

Next, by the definition of κ_i -close to breaking and estimates on derivatives in the proof of Gromov–Hofer compactness, after applying the relevant translations in the domain or in the target and passing to a subsequence, we can choose a sequence $T_2'(\epsilon_i) \rightarrow \infty$ such that $-T_2'(\epsilon_i) < -T_1$ and there are rough initial estimates

$$(A-8-2) \quad \|\zeta_+^{\epsilon_i}(-T_1 - 1)\|_{L^2} \leq c\kappa_i, \quad \|\zeta_-^{\epsilon_i}(-T_2'(\epsilon_i))\|_{L^2} \leq c\kappa_i,$$

where $c > 0$ is independent of ϵ_i or κ_i .

Normalization We normalize u^{ϵ_i} so that, at $s = -T_1$, the g_1 term of the Fourier series of $\eta^{u^{\epsilon_i}}$ is equal to $(b, 0)$ and the g_0 term is equal to $(0, h_{\epsilon_i})$, where $h_{\epsilon_i} \rightarrow 0$ as $i \rightarrow \infty$. This is possible because $\eta^{u^{\epsilon_i}}(-T_1)$, before normalization, is close to $(b, 0)$ and the g_0 term in the Fourier series for the negative end of u_+

vanishes. Similarly, we normalize v^{ϵ_i} by translating slightly in the target \mathbb{R} -direction, so that the g_1 term of ζ^{ϵ_i} is zero.

Definition A.8.2 An element of $\ker D_+^\delta$ or $\ker D_-^{\epsilon_i, \alpha, \delta}$ (from Section A.5.4) is a *nontranslation* element if it is nonzero and does not correspond to an \mathbb{R} -translation of the domain or target.

A sufficient condition for detecting a nontranslation element of $\ker D_+^\delta$ is given in Lemma A.8.6 in terms of the coefficient of g_1 in the Fourier expansion.

Idea of proof The idea of the proof is to start with $v^{\epsilon_i} - u^{\epsilon_i}$ for $\epsilon_i > 0$ small and construct a nontranslation element of $\ker D_+^\delta$ or $\ker D_-^{\epsilon_i, 0, \delta}$ (taking $\alpha = 0$ suffices) by damping out and inverting the error. The damping out occurs on a long neck region $[-T_3(\epsilon_i), -T_1] \times S^1$ (with $-T_3(\epsilon_i)$ defined later) that is mapped to B by $\eta^{u^{\epsilon_i}}$ and $\eta^{v^{\epsilon_i}}$. The D_+^δ and $D_-^{\epsilon_i, 0, \delta}$ cases respectively correspond to Cases 1 and 2 below. (There is a slight complication in the $D_-^{\epsilon_i, 0, \delta}$ case, which will be explained in Case 2.) The existence of a nontranslation element is a contradiction.

By (A-8-1), $\zeta^{\epsilon_i}|_{[-T_3(\epsilon_i), -T_1] \times S^1}$ can be written as a Fourier series

$$(A-8-3) \quad \zeta^{\epsilon_i}(s, t) = \sum_{j=-\infty}^{\infty} d_j^{\epsilon_i} e^{\lambda_j s} g_j(t).$$

We write $(\cdot)_-, (\cdot)_0$ and $(\cdot)_+$ for the L^2 -projections of $(\cdot) = \zeta^{\epsilon_i}$ etc to the negative, null and positive eigenspaces of A , and write $(\cdot)(s_0)$ for $(\cdot)|_{s=s_0}$. By our normalization we may assume that $d_1^{\epsilon_i} = 0$.

Lemma A.8.3 Fix $T'_1 \in [T_1 + 1, T'_2(\epsilon_i)]$. For all $s \in [-T'_1, -T_1]$,

$$(A-8-4) \quad \|\zeta_+^{\epsilon_i}(s)\|_{L_1^2} \leq \|\zeta_+^{\epsilon_i}(-T_1)\|_{L_1^2} \cdot e^{\lambda(s+T_1)},$$

$$(A-8-5) \quad \|\zeta_-^{\epsilon_i}(s)\|_{L_1^2} \leq \|\zeta_-^{\epsilon_i}(-T'_1)\|_{L_1^2} \cdot e^{-\lambda(s+T'_1)},$$

where $\lambda = \min(\lambda_1, |\lambda_{-1}|)$ and L_1^2 refers to the L^2 -Sobolev space with one derivative.

Proof We prove the first inequality. By the Fourier expansion (A-8-3) and Parseval's identity, we have

$$\|\zeta_+^{\epsilon_i}(s)\|_{L_1^2}^2 = \sum_{j \geq 1} d_j^2 (1 + \lambda_j^2) e^{2\lambda_j s}, \quad \|\zeta_+^{\epsilon_i}(-T_1)\|_{L_1^2}^2 \cdot e^{2\lambda(s+T_1)} = \sum_{j \geq 1} d_j^2 (1 + \lambda_j^2) e^{2(\lambda - \lambda_j)T_1 + 2\lambda s}.$$

Then (A-8-4) follows from the inequality

$$e^{\lambda_j s} \leq e^{(\lambda - \lambda_j)T_1 + \lambda s},$$

which holds for $j > 0$. To prove this inequality we divide the second term by the first and observe that $e^{(\lambda - \lambda_j)(T_1 + s)} \geq 1$ because $\lambda - \lambda_j \leq 0$ and $T_1 + s \leq 0$.

Now we prove the second inequality. We have

$$\|\zeta_-^{\epsilon_i}(s)\|_{L^2_1}^2 = \sum_{j<0} d_j^2(1 + \lambda_j^2)e^{2\lambda_j s}, \quad \|\zeta_-^{\epsilon_i}(-T'_1)\|_{L^2_1}^2 \cdot e^{-2\lambda(s+T'_1)} = \sum_{j<0} d_j^2(1 + \lambda_j^2)e^{-2(\lambda_j+\lambda)T'_1-2\lambda s}.$$

Then (A-8-4) follows from the inequality

$$e^{\lambda_j s} \leq e^{-(\lambda_j+\lambda)T'_1-\lambda s},$$

which holds for $j < 0$ because $\lambda + \lambda_j \leq 0$ and $s + T'_1 \geq 0$. □

There are two cases to consider:

- (1) $\|\zeta_0^{\epsilon_i}(-T_1 - 1) + \zeta_+^{\epsilon_i}(-T_1 - 1)\|_{L^2_1} \geq \|\zeta_-^{\epsilon_i}(-T'_2(\epsilon_i))\|_{L^2_1}$ holds for infinitely many indices i , or
- (2) $\|\zeta_0^{\epsilon_i}(-T_1 - 1) + \zeta_+^{\epsilon_i}(-T_1 - 1)\|_{L^2_1} \leq \|\zeta_-^{\epsilon_i}(-T'_2(\epsilon_i))\|_{L^2_1}$ holds for infinitely many indices i .

Note that the two cases are not mutually exclusive.

Case 1 Up to extracting a subsequence, we assume that, for every i ,

$$(A-8-6) \quad \|\zeta_0^{\epsilon_i}(-T_1 - 1) + \zeta_+^{\epsilon_i}(-T_1 - 1)\|_{L^2_1} \geq \|\zeta_-^{\epsilon_i}(-T'_2(\epsilon_i))\|_{L^2_1}.$$

By (A-8-5) with $T'_1 = T'_2(\epsilon_i)$ and $s = -T_1 - 1$,

$$(A-8-7) \quad \begin{aligned} \|\zeta_-^{\epsilon_i}(-T_1 - 1)\|_{L^2_1} &\leq \|\zeta_-^{\epsilon_i}(-T'_2(\epsilon_i))\|_{L^2_1} \cdot e^{\lambda(-T'_2(\epsilon_i)+T_1+1)} \\ &\leq \|\zeta_0^{\epsilon_i}(-T_1 - 1) + \zeta_+^{\epsilon_i}(-T_1 - 1)\|_{L^2_1} \cdot e^{\lambda(-T'_2(\epsilon_i)+T_1+1)}. \end{aligned}$$

Let $\xi^{\epsilon_i} = (\xi_1^{\epsilon_i}, \xi_2^{\epsilon_i}) \in \mathcal{H}_{1,g_\delta}(\dot{F}, N_+) \oplus \mathbb{R}\langle \tilde{\partial}_\theta \rangle$ be such that

- on $\dot{F} - (-\infty, -T_1] \times S^1$, $\xi^{\epsilon_i} = \eta^{v^{\epsilon_i}} - \eta^{u^{\epsilon_i}}$, where $u^{\epsilon_i} = \exp_{u_+} \eta^{u^{\epsilon_i}}$, $v^{\epsilon_i} = \exp_{u_+} \eta^{v^{\epsilon_i}}$, and $\eta^{u^{\epsilon_i}}$ and $\eta^{v^{\epsilon_i}}$ are viewed as sections of the normal bundle N_+ to u_+ ;
- on $(-\infty, -T_1] \times S^1$, $\xi^{\epsilon_i} = \beta(s + T_1 + 1)\zeta_-^{\epsilon_i}(s, t) + \zeta_0^{\epsilon_i}(s, t) + \zeta_+^{\epsilon_i}(s, t)$ and $\xi_2^{\epsilon_i} = \zeta_0^{\epsilon_i}$.

Recall on the negative end of u_+ we are identifying $N_+ \simeq TA_a \simeq \mathbb{R}^2$ with coordinates y, θ . As before, $\beta: \mathbb{R} \rightarrow [0, 1]$ is a nondecreasing function such that $\beta(s) = 0$ if $s \leq 0$ and $\beta(s) = 1$ if $s \geq 1$. Informally, we are damping out the $\zeta_-^{\epsilon_i}$ term to zero for $s < -T_1$, under the condition that it is much smaller than $\zeta_0^{\epsilon_i} + \zeta_+^{\epsilon_i}$ at $s = -T_1$.

Notation A.8.4 We denote the norm on $\mathbb{R}\langle \tilde{\partial}_\theta \rangle$ by $\|\cdot\|_\circ$ and the norm on $\mathcal{H}_{1,g_\delta}(\dot{F}, N_+) \oplus \mathbb{R}\langle \tilde{\partial}_\theta \rangle$ by $\|\xi^{\epsilon_i}\|_\bullet = \|\xi_1^{\epsilon_i}\|_{*,g_\delta} + \|\xi_2^{\epsilon_i}\|_\circ$.

Lemma A.8.5 *There exist constants $C_i > 0$ with $\lim_{i \rightarrow +\infty} C_i = 0$ such that*

$$\|D_+^\delta \xi^{\epsilon_i}\|_{g_\delta} \leq C_i (\|\xi_1^{\epsilon_i}\|_{*,g_\delta} + \|\xi_2^{\epsilon_i}\|_\circ) = C_i \|\xi^{\epsilon_i}\|_\bullet.$$

Proof On $(-\infty, -T_1] \times S^1$, we use the fact that $D_+^\delta \zeta_*^{\epsilon_i} = 0$ for $* = -, 0, +$, to bound the contribution to $\|D_+^\delta \xi^{\epsilon_i}\|_{g_\delta}$ from above as follows:

$$\begin{aligned}
 \text{(A-8-8)} \quad & \|D_+^\delta(\beta(s + T_1 + 1)\zeta_-^{\epsilon_i}(s, t))\|_{g_\delta} \\
 &= \|\beta'(s + T_1 + 1)\zeta_-^{\epsilon_i}(s, t)\|_{g_\delta} \\
 &\leq C \left(\sup_{s \in [-T_1-1, -T_1]} g_\delta(s) \|\zeta_-^{\epsilon_i}(s)\|_{L^2} + \sup_{s \in [-T_1-1, -T_1]} g_\delta(s) |\zeta_-^{\epsilon_i}(s)|_{C^0} \right) \\
 &\leq C \sup_{s \in [-T_1-1, -T_1]} g_\delta(s) \|\zeta_-^{\epsilon_i}(s)\|_{L_1^2} \\
 &\leq C g_\delta(-T_1 - 1) \|\zeta_-^{\epsilon_i}(-T_1 - 1)\|_{L_1^2} \\
 &\leq C g_\delta(-T_1) e^{\lambda(-T_2'(\epsilon_i) + T_1 + 1)} \|\zeta_0^{\epsilon_i}(-T_1 - 1) + \zeta_+^{\epsilon_i}(-T_1 - 1)\|_{L_1^2} \\
 &\leq C e^{\lambda(-T_2'(\epsilon_i) + T_1)} (\|\xi_1^{\epsilon_i}\|_{*,g_\delta} + \|\xi_2^{\epsilon_i}\|_{\circ}).
 \end{aligned}$$

The first line to the second follows from the definition of $\|\cdot\|$ (equation (A-5-7)) and an easy C^0 -bound of the right-hand term of the definition of $\|\cdot\|$; the second line to the third uses a standard Sobolev inequality (ie there is a bounded inclusion map $L_1^2(S^1) \rightarrow C^0(S^1)$); the third line to the fourth follows from (A-8-5) applied to $T_1' = T_1 + 1$; and the fourth line to the fifth uses (A-8-7). The fifth line to the sixth follows from

$$\begin{aligned}
 \|\xi_1^{\epsilon_i}\|_{*,g_\delta} &\geq \|\xi_1^{\epsilon_i}|_{[-T_1-1, -T_1] \times S^1}\|_{*,g_\delta} \geq \|\zeta_+^{\epsilon_i}|_{[-T_1-1, -T_1] \times S^1}\|_{*,g_\delta} \\
 &\geq C \left(\int_{[-T_1-1, -T_1]} \int_{S^1} g_\delta^2 |\zeta_+^{\epsilon_i}|^2 \right)^{1/2} + C \left(\int_{[-T_1-1, -T_1]} \int_{S^1} g_\delta^2 |\nabla \zeta_+^{\epsilon_i}|^2 \right)^{1/2} \\
 &\geq C g_\delta(-T_1) (\|\zeta_+^{\epsilon_i}(-T_1 - 1)\|_{L^2} + \|\nabla \zeta_+^{\epsilon_i}(-T_1 - 1)\|_{L^2}).
 \end{aligned}$$

On the other hand, writing $\|\cdot\|'_{g_\delta}$ and $\|\cdot\|''_{g_\delta}$ for the restrictions of $\|\cdot\|_{g_\delta}$ to $\dot{F} - (-\infty, -T_1] \times S^1$ and $[-T_1, -T_0] \times S^1$, writing $v^{\epsilon_i} = \exp_{u^{\epsilon_i}}(P^{-1}\xi^{\epsilon_i})$ on $\dot{F} - (-\infty, -T_1] \times S^1$, where P is the parallel transport of the appropriate bundles from u^{ϵ_i} to u_+ , and using the fact that

$$\tilde{\xi}^{\epsilon_i} = \xi^{\epsilon_i} + \mathcal{B}(\eta^{u^{\epsilon_i}}, \xi^{\epsilon_i}) + \mathcal{Q}(\xi^{\epsilon_i}),$$

where $\mathcal{B}(\eta^{u^{\epsilon_i}}, \xi^{\epsilon_i})$ is bilinear in $\eta^{u^{\epsilon_i}}$ and ξ^{ϵ_i} and $\mathcal{Q}(\xi^{\epsilon_i})$ is quadratic in ξ^{ϵ_i} , both with coefficients which are smooth coefficients of $\eta^{u^{\epsilon_i}}$ and ξ^{ϵ_i} , the contribution to $\|D_+^\delta \xi^{\epsilon_i}\|_{g_\delta}$ on F' is bounded above by

$$\begin{aligned}
 \|D_+^\delta \xi^{\epsilon_i}\|'_{g_\delta} &= \|D_+^\delta \xi^{\epsilon_i} - P \bar{\partial}_{J_{f_{\epsilon_i}}} \exp_{u^{\epsilon_i}}(P^{-1}\tilde{\xi}^{\epsilon_i})\|'_{g_\delta} \\
 &\leq \|D_+^\delta \xi^{\epsilon_i} - P D_{u^{\epsilon_i}}^\delta P^{-1} \xi^{\epsilon_i}\|'_{g_\delta} + \|P(D_{u^{\epsilon_i}}^\delta P^{-1} \xi^{\epsilon_i} - \bar{\partial}_{J_{f_{\epsilon_i}}} \exp_{u^{\epsilon_i}} P^{-1} \xi^{\epsilon_i})\|'_{g_\delta} \\
 &\quad + \|P(\bar{\partial}_{J_{f_{\epsilon_i}}} \exp_{u^{\epsilon_i}} P^{-1} \xi^{\epsilon_i} - \bar{\partial}_{J_{f_{\epsilon_i}}} \exp_{u^{\epsilon_i}} P^{-1} \tilde{\xi}^{\epsilon_i})\|'_{g_\delta} \\
 &\leq C_i \|\xi^{\epsilon_i}\|'_{*,g_\delta} \leq C_i (\|\xi_1^{\epsilon_i}\|_{*,g_\delta} + \|\xi_2^{\epsilon_i}\|''_{*,g_\delta}) \leq C_i (\|\xi_1^{\epsilon_i}\|_{*,g_\delta} + e^{\delta(T_1 - T_0)} \|\xi_2^{\epsilon_i}\|_{\circ}),
 \end{aligned}$$

where $\lim_{i \rightarrow \infty} C_i = 0$. (Recall that b and $T_1(b)$ are constants that were fixed at the beginning of Section A.8.)

The two estimates together imply the lemma. □

In view of Lemma A.8.5, inverting the error using $(D_+^\delta)^{-1}$ (as before the image of $(D_+^\delta)^{-1}$ is L^2 -orthogonal to $\ker D_+^\delta$) yields

$$(\xi')^{\epsilon_i} = \xi^{\epsilon_i} - (D_+^\delta)^{-1}(D_+^\delta \xi^{\epsilon_i}) \in \ker D_+^\delta,$$

so that $\|\xi^{\epsilon_i}\|_\bullet \gg \|(D_+^\delta)^{-1}(D_+^\delta \xi^{\epsilon_i})\|_\bullet$, which implies that $(\xi')^{\epsilon_i} \neq 0$. We define

$$\bar{\xi}^{\epsilon_i} = \frac{\xi^{\epsilon_i}}{\|(\xi')^{\epsilon_i}\|_\bullet}, \quad (\bar{\xi}')^{\epsilon_i} = \frac{(\xi')^{\epsilon_i}}{\|(\xi')^{\epsilon_i}\|_\bullet}.$$

Lemma A.8.6 *There exists a nontranslation element of $\ker D_+^\delta$.*

Proof So far we have constructed sequences $\{\bar{\xi}^{\epsilon_i}\}$ and $\{(\bar{\xi}')^{\epsilon_i}\}$ such that

- (1) the Fourier coefficient relative to g_1 is $\bar{d}_1^{\epsilon_i} = 0$ for all $\bar{\xi}^{\epsilon_i}$;
- (2) $\|(\bar{\xi}')^{\epsilon_i}\|_\bullet = 1$;
- (3) $(\bar{\xi}')^{\epsilon_i} \in \ker D_+^\delta$; and
- (4) $\|(\bar{\xi}')^{\epsilon_i} - \bar{\xi}^{\epsilon_i}\|_\bullet \rightarrow 0$ as $i \rightarrow \infty$.

Since $\ker D_+^\delta$ is finite-dimensional, the unit ball of $\ker D_+^\delta$ is compact and, after possibly passing to a subsequence $(\bar{\xi}')^{\epsilon_i}$, converges to a nonzero $\xi' \in \ker D_+^\delta$. Then (4) implies that $\|\bar{\xi}^{\epsilon_i} - \xi'\|_\bullet \rightarrow 0$ and therefore, from Lemma A.5.1, we obtain $\bar{\xi}^{\epsilon_i}(-T_1) \rightarrow \xi'(-T_1)$ in C^0 . This in turn implies that $\bar{d}_1^{\epsilon_i} \rightarrow d'_1$, where $\bar{d}_1^{\epsilon_i}$ and d'_1 are the Fourier coefficients of g_1 in $\bar{\xi}^{\epsilon_i}$ and ξ' ; this is because the Fourier coefficients can be extracted by integration. Hence $d'_1 = 0$.

Finally we explain why $d'_1 = 0$ implies that ξ' is a nontranslation element: Recall that $u_+(s, t) = (s, t, \sum_{i=1}^\infty c_i e^{\lambda_i s} g_i(t))$ with $c_1 > 0$ at the negative end (see the beginning of Section A.4). Let u_+^σ be the translate of u_+ by $\sigma \in \mathbb{R}$ in the symplectization direction. Then, at the negative end,

$$u_+^\sigma(s, t) = \left(s + \sigma, t, \sum_{i=1}^\infty c_i e^{\lambda_i s} g_i(t) \right),$$

or, after the change of coordinates $(s + \sigma, t) \mapsto (s, t)$ at the negative end of \dot{F} ,

$$u_+^\sigma(s, t) = \left(s, t, \sum_{i=1}^\infty c_i e^{\lambda_i (s-\sigma)} g_i(t) \right).$$

Then a translation element is a nontrivial multiple of the projection of $\partial u_+^\sigma / \partial \sigma|_{\sigma=0}$ to the normal bundle N_+ , ie $-\sum_{i=1}^\infty c_i \lambda_i e^{\lambda_i s} g_i(t)$, and has nontrivial $g_1(t)$ -coefficient. □

The existence of a nontranslation element of $\ker D_+^\delta$ is a contradiction.

Case 2 Up to extracting a subsequence, we assume that, for every i ,

$$(A-8-9) \quad \|\zeta_0^{\epsilon_i}(-T_1 - 1) + \zeta_+^{\epsilon_i}(-T_1 - 1)\|_{L^2} \leq \|\zeta_-^{\epsilon_i}(-T_2'(\epsilon_i))\|_{L^2}.$$

Let $-T_4(\epsilon_i) < -T_3(\epsilon_i) < -T_2'(\epsilon_i)$ be such that $T_3(\epsilon_i) - T_2'(\epsilon_i), T_4(\epsilon_i) - T_3(\epsilon_i) \rightarrow \infty$ as $i \rightarrow \infty$ and

$$\text{Im } u^{\epsilon_i}|_{s=-T_3(\epsilon_i)} \subset \left\{ -\frac{1}{6} \leq \theta \leq -\frac{1}{6} + \kappa_i \right\}, \quad \text{Im } u^{\epsilon_i}|_{s=-T_4(\epsilon_i)} \subset \left\{ -\frac{1}{5} - \kappa_i \leq \theta \leq -\frac{1}{5} \right\},$$

where Im denotes the image. Using (A-8-5) with $T'_1 = T_3(\epsilon_i)$ and $s = -T_2(\epsilon_i)$, we have

$$(A-8-10) \quad \|\zeta_0^{\epsilon_i}(-T_1 - 1) + \zeta_+^{\epsilon_i}(-T_1 - 1)\|_{L^2_1} \leq C e^{\lambda(-T_3(\epsilon_i) + T'_2(\epsilon_i))} \cdot \|\zeta_-^{\epsilon_i}(-T_3(\epsilon_i))\|_{L^2_1}.$$

Complication There is one complication. By (A-1-3), the $\bar{\partial}$ -operator \mathcal{D}_{ϵ_i} is linear on $-\frac{1}{4} \leq \theta \leq -\frac{1}{5}$, with respect to $(y, \theta + \frac{1}{4})$, because $\bar{g}'_{\mathcal{N}}(\theta) = C(\theta + \frac{1}{4})$, and each of $\eta = \eta^{v^{\epsilon_i}}$, $\eta^{u^{\epsilon_i}}$ satisfies the equation

$$\mathcal{D}_{\epsilon_i} \eta = \frac{\partial \eta}{\partial s} + j_0 \frac{\partial \eta}{\partial t} - \left(\epsilon_i C \left(\eta_2 + \frac{1}{4} \right) \right) = 0,$$

where $\eta = (\eta_1, \eta_2)$, ie η_1 is the y -coordinate and η_2 the θ -coordinate of η . Hence $\zeta^{\epsilon_i}(s, t)$ admits a Fourier expansion at the negative end whose leading term has the form $(k_{i1}e^s, k_{i2}e^{\epsilon C s})$ for constants k_{i1} and k_{i2} . However, a section with growth rate $e^{\epsilon C s}$ as $s \rightarrow \infty$ is not in $\mathcal{H}_{1, h_\delta}(\mathbb{R} \times S^1, N_{-}^{\epsilon_i, 0})$ since we have been assuming that $0 < \epsilon_i C < \delta$; in fact, $\epsilon_i \rightarrow 0$ while δ is constant. To circumvent this difficulty we switch to

$$D_{-}^{\epsilon_i, 0, -\delta} : \mathcal{H}_{1, h_{-\delta}}(\mathbb{R} \times S^1, N_{-}^{\epsilon_i, 0}) \rightarrow \mathcal{H}_{1, h_{-\delta}}(\mathbb{R} \times S^1, \Lambda^{0,1} N_{-}^{\epsilon_i, 0}),$$

where $\delta > 0$ is sufficiently small. The analog of Lemma A.5.4 also holds for $h_{-\delta}$, ie the operators $D_{-}^{\epsilon_i, 0, -\delta}$ are invertible with bounded inverses that are uniform with respect to ϵ_i .

Let ξ^{ϵ_i} be the section of the normal bundle $N_{-}^{\epsilon_i, 0} = TA_a$ to $u_{-}^{\epsilon_i, 0}$ such that

- $\xi^{\epsilon_i} = \zeta^{\epsilon_i}$ on $(-\infty, -T_3(\epsilon_i)] \times S^1$;
- $\xi^{\epsilon_i} = (1 - \beta(s + T_1 + 1))\zeta_-^{\epsilon_i}(s, t) + (1 - \beta(s + T_3(\epsilon_i))) (\zeta_0^{\epsilon_i}(s, t) + \zeta_+^{\epsilon_i}(s, t))$ on $[-T_3(\epsilon_i), -T_1] \times S^1$ (here we write $\zeta_+, \zeta_0, \zeta_-$ for the L^2 -projections of ζ to the positive, null, and negative eigenspaces of A); and
- $\xi^{\epsilon_i} = 0$ on $[-T_1, \infty) \times S^1$.

Informally, we damp out $\zeta_-^{\epsilon_i}$ to zero for $s \geq -T_1$ and $\zeta_0^{\epsilon_i} + \zeta_+^{\epsilon_i}$ to zero for $s \geq -T_3(\epsilon_i) + 1$ so that the damped-out $\zeta_-^{\epsilon_i}$ dominates. By the previous paragraph, $\xi^{\epsilon_i} \in \mathcal{H}_{1, h_{-\delta}}(\mathbb{R} \times S^1, N_{-}^{\epsilon_i, 0})$. Also $D_{-}^{\epsilon_i, 0, -\delta} \xi^{\epsilon_i}$ has support on

$$(A-8-11) \quad \{-T_4(\epsilon_i) \leq s \leq -T_3(\epsilon_i) + 1\} \cup \{-T_1 - 1 \leq s \leq -T_1\}.$$

One can compute, using (A-8-11), estimate (A-8-10), the method of estimating (A-8-8), and the error estimate between $D_{-}^{\epsilon_i, 0, -\delta}$ and the actual normal $\bar{\partial}_{J_{f_{\epsilon_i}}}$ -operator, that

$$\|D_{-}^{\epsilon_i, 0, -\delta} \xi^{\epsilon_i}\|_{h_{-\delta}} \ll \|\xi^{\epsilon_i}\|_{*, h_{-\delta}}.$$

Hence inverting the error using $(D_{-}^{\epsilon_i, 0, -\delta})^{-1}$ yields

$$(\xi')^{\epsilon_i} = \xi^{\epsilon_i} - (D_{-}^{\epsilon_i, 0, -\delta})^{-1} (D_{-}^{\epsilon_i, 0, -\delta} \xi^{\epsilon_i}) \in \ker D_{-}^{\epsilon_i, 0, -\delta},$$

so that $\|\xi^{\epsilon_i}\|_{*, h_{-\delta}} \gg \|(D_{-}^{\epsilon_i, 0, -\delta})^{-1} (D_{-}^{\epsilon_i, 0, -\delta} \xi^{\epsilon_i})\|_{*, h_{-\delta}}$, which implies that $(\xi')^{\epsilon_i} \neq 0$.

The existence of a nontrivial element of $\ker D_{-}^{\epsilon_i, 0, -\delta}$ contradicts Lemma A.5.4. This completes the proof of Theorem A.2.6.

A.9 How to recover the contact case

In this subsection we explain how to recover the contact case from the stable Hamiltonian case. The brief idea is to start with the stable Hamiltonian case for which Morse–Bott gluing holds, perturb it to the contact case, and use the bifurcation method to establish Morse–Bott gluing in the contact case.

Let a and c be the positive numbers satisfying $0 < b < a < c < 1$ introduced in Section A.1 and subject to the conditions (\dagger_0) and (\dagger_1) . Recall the smooth functions

$$f, f_\epsilon: [-1, 1] \times T^2 \rightarrow \mathbb{R}$$

given by (A-1-2).

Warning A.9.1 The following have different meanings in this subsection from the previous subsections of the appendix: the real parameter δ in this subsection is unrelated to the weight appearing in the Morrey norms, and the functions g, h, g_δ and h_δ appearing in this subsection are unrelated to the functions with the same names appearing in the previous subsections of the appendix.

We then define smooth functions

$$g, h: [-1, 1] \rightarrow \mathbb{R},$$

such that

- (i) g is odd,
- (ii) $g(y) = 0$ on $[-a, a]$,
- (iii) $g'(y) > 0$ on $(a, 1]$ and $[-1, -a)$,
- (iv) $g(y) = y$ on $y \geq c$ and $y \leq -c$,
- (v) $h(0) = 0$, and
- (vi) $h'(y) = g'(y) \partial f / \partial y = g'(y)y$.

In particular, $h(y) = 0$ on $[-a, a]$.

We define differential forms

$$(A-9-1) \quad \alpha = dt + h(y) dt + g(y) d\theta, \quad \omega = df \wedge dt + dy \wedge d\theta, \quad \omega_\epsilon = df_\epsilon \wedge dt + dy \wedge d\theta$$

on $[-1, 1] \times T^2$. (Here without loss of generality we are suppressing some constants that appeared in (4-1-1).)

Claim A.9.2 *The pairs (α, ω) and $(\alpha, \omega_\epsilon)$ on $[-1, 1] \times T^2$ are stable Hamiltonian structures.*

Proof It is immediate that $d\omega = d\omega_\epsilon = 0$.

Next we show that $\ker d\alpha \supset \ker \omega$ and $\ker d\alpha \supset \ker \omega_\epsilon$. We have

$$d\alpha = h'(y) dy \wedge dt + g'(y) dy \wedge d\theta = g'(y) \frac{\partial f}{\partial y} dy \wedge dt + g'(y) dy \wedge d\theta.$$

On $-a \leq y \leq a$, $d\alpha = 0$ and hence $\ker d\alpha \supset \ker \omega$. Outside of $-a \leq y \leq a$, $g'(y) \neq 0$ and

$$\ker d\alpha = \mathbb{R} \left\langle \frac{\partial}{\partial t} - \frac{\partial f}{\partial y} \frac{\partial}{\partial \theta} \right\rangle = \ker \omega.$$

Moreover, outside of $-a \leq y \leq a$, $f_\epsilon = f$ and $\omega = \omega_\epsilon$.

Finally,

$$\alpha \wedge \omega = \alpha \wedge \omega_\epsilon = dt \wedge dy \wedge d\theta > 0$$

on $-a \leq y \leq a$ and

$$\alpha \wedge \omega = \alpha \wedge \omega_\epsilon = (1 + h(y) - g(y) \frac{\partial f}{\partial y}) dt \wedge dy \wedge d\theta = (1 + h(y) - g(y)y) dt \wedge dy \wedge d\theta$$

outside of $-a \leq y \leq a$. By (vi), $(h(y) - g(y)y)' = -g(y)$. Since $|g(y)| < 1$ except when $y = 1$, $1 + h(y) - g(y)y > 0$.

Hence (α, ω) and $(\alpha, \omega_\epsilon)$ are both stable Hamiltonian structures. □

Claim A.9.3 (A1) On $[-a, a] \times T^2$,

$$(\alpha, \omega) = (dt, df \wedge dt + dy \wedge d\theta), \quad (\alpha, \omega_\epsilon) = (dt, df_\epsilon \wedge dt + dy \wedge d\theta).$$

(A2) On $([-1, -a) \cup (a, 1]) \times T^2$, the stable Hamiltonian structures (α, ω) and $(\alpha, \omega_\epsilon)$ agree and $d\alpha$ is a positive function $g'(y)$ times $\omega = \omega_\epsilon$.

(A3) On $([-1, -c) \cup (c, 1]) \times T^2$, $g'(y) = 1$, and (α, ω) and $(\alpha, \omega_\epsilon)$ are contact.

Proof This is immediate from the definitions and the proof of Claim A.9.2. □

In view of Claim A.9.3, there exists an extension of $(\alpha, \omega) = (\alpha, \omega_\epsilon)$ to $(\alpha, d\alpha)$ on $M - ([-1, 1] \times T^2)$. (In practice, we start with a contact form α on all of M and modify it to the stable Hamiltonian structures (α, ω) and $(\alpha, \omega_\epsilon)$ on $[-1, 1] \times T^2$.)

Let J_f and J_{f_ϵ} be almost complex structures on $\mathbb{R} \times M$ such that

(A4) on the complement of $\mathbb{R} \times [-a, a] \times T^2$, J_f and J_{f_ϵ} agree and are adapted to the same contact structure;

(A5) on $\mathbb{R} \times [-1, 1] \times T^2$, J_f and J_{f_ϵ} are adapted to the stable Hamiltonian structures (α, ω) and $(\alpha, \omega_\epsilon)$;

(A6) J_f is Morse–Bott regular, J_{f_ϵ} is regular (at least for the moduli spaces that are involved in the Morse–Bott gluing), and the pair satisfies Morse–Bott gluing (ie Theorem 4.4.3(2)–(3)).

The existence of such J_f and J_{f_ϵ} follows from Theorem A.2.1.

The key point is the following lemma, which allows us to perturb to the contact case:

Lemma A.9.4 *There exist almost complex structures $J'_{f,\delta}$ and $J'_{f_\epsilon,\delta}$ that are C^1 -close to J_f and J_{f_ϵ} and contact forms α'_δ and $\alpha'_{\epsilon,\delta}$ that are C^1 -close to α (here the size of the perturbations depend on $\delta > 0$) such that:*

- (1) *On the complement of $\mathbb{R} \times [-c, c] \times T^2$, $J_f, J_{f_\epsilon}, J'_{f,\delta}$ and $J'_{f_\epsilon,\delta}$ all agree.*
- (2) *$J'_{f,\delta}$ and $J'_{f_\epsilon,\delta}$ are adapted to α'_δ and $\alpha'_{\epsilon,\delta}$, respectively.*
- (3) *The stable Hamiltonian vector fields corresponding to J_f and $J'_{f,\delta}$ (and those corresponding to J_{f_ϵ} and $J'_{f_\epsilon,\delta}$) are parallel.*
- (4) *On $\mathbb{R} \times [-a, a] \times T^2$, α'_δ and $\alpha'_{\epsilon,\delta}$ are as given in (4-1-1) and (P1)–(P4) in Section 4.1 with $C = 1$ and $J'_{f,\delta}$ and $J'_{f_\epsilon,\delta}$ satisfy (*) in Section 4.2 and (**) in Section 4.4.*

Proof For $\delta > 0$ small, let $g_\delta : [-1, 1] \rightarrow \mathbb{R}$ be a smooth function which is a perturbation of g such that

- (i) g_δ is odd,
- (ii') $g_\delta(y) = \delta y$ on $[-a, a]$,

and (iii) and (iv) still hold. We define

$$\begin{aligned} \alpha'_\delta &= dt + \delta(f dt + y d\theta) && \text{if } y \in [-a, a], \\ \alpha'_{\epsilon,\delta} &= dt + \delta(f_\epsilon dt + y d\theta) && \text{if } y \in [-a, a], \\ \alpha'_\delta &= \alpha'_{\epsilon,\delta} = dt + h_\delta(y) dt + g_\delta(y) d\theta && \text{if } y \notin [-a, a], \end{aligned}$$

and $h'_\delta(y) = g'_\delta(y) \partial f / \partial y$ for $y \notin [-a, a]$ and $h_\delta(\pm a) = \delta f(\pm a)$. If $c \gg a$, then it is not hard to see that we can choose g_δ such that $h_\delta(\pm c) = h(\pm c)$. Then (α'_δ, ω) and $(\alpha'_{\epsilon,\delta}, \omega_\epsilon)$ are stable Hamiltonian structures corresponding to contact structures, and are close to (α, ω) and $(\alpha, \omega_\epsilon)$. (Strictly speaking, $d\alpha'_\delta = \phi_1 \omega$ and $d\alpha'_{\epsilon,\delta} = \phi_2 \omega_\epsilon$ for some functions ϕ_1 and ϕ_2 .)

We verify the contact property for α'_δ and $\alpha'_{\epsilon,\delta}$: For $y \in [-a, a]$,

$$\alpha'_\delta \wedge d\alpha'_\delta = (1 + \delta f) dt \wedge \delta dy d\theta + \delta y d\theta \wedge \delta df dt > 0,$$

since we are assuming that $\delta > 0$ is small. Similarly, $\alpha'_{\epsilon,\delta}$ is contact by replacing f by f_ϵ on $[-a, a]$. For $y \notin [-a, a]$, $\alpha'_\delta = \alpha_{\epsilon,\delta}$ and

$$\alpha'_\delta \wedge d\alpha'_\delta = (1 + h_\delta) dt \wedge g'_\delta(y) dy d\theta + g_\delta(y) d\theta \wedge h'_\delta(y) dy dt = g'_\delta(y)[(1 + h_\delta) - g_\delta(y)y] dt dy d\theta > 0$$

as in the proof of Claim A.9.2.

Let $J'_{f,\delta}$ and $J'_{f_\epsilon,\delta}$ be the corresponding adapted almost complex structures that are close to J_f and J_{f_ϵ} and subject to the condition that the projections of $J'_{f,\delta}|_{\ker \alpha'}$ and $J'_{f_\epsilon,\delta}|_{\ker \alpha'_\epsilon}$ to $[-1, 1] \times (\mathbb{R}/\mathbb{Z})$ with coordinates (y, θ) is the standard complex structure $\partial/\partial y \mapsto \partial/\partial \theta$.

The C^1 -closeness and (1)–(4) are immediate from the construction. □

For the next lemma we introduce the following notation:

Notation A.9.5 If \mathcal{M} is a moduli space of J -holomorphic curves in a symplectization for a cylindrical almost complex structure J , we denote by $\widehat{\mathcal{M}} := \mathcal{M}/\mathbb{R}$ the quotient of \mathcal{M} by translations in the symplectization direction.

Lemma A.9.6 *There exist $\delta > 0$ sufficiently small and $\epsilon_0 = \epsilon_0(\delta) > 0$ such that Theorem 4.4.3(2)–(3) hold for any ϵ satisfying $0 < \epsilon < \epsilon_0$, with J_0 and J_ϵ replaced by $J'_{f,\delta}$ and $J'_{f_\epsilon,\delta}$.*

Proof Consider the $I = \text{ind} = 1$, unconstrained, Morse–Bott regular moduli space $\mathcal{M}_{J_f}^{I=\text{ind}=1}(\mathcal{Y}; \mathcal{N})$ from Section A.1. Then $\widehat{\mathcal{M}}_{J_f}^{I=\text{ind}=1}(\mathcal{Y}; \mathcal{N})$ consists of a finite number of holomorphic maps u_+ . If $\delta > 0$ is small, then $J'_{f,\delta}$ is also Morse–Bott regular since it is close to J_f and

$$(A-9-2) \quad \widehat{\mathcal{M}}_{J_f}^{I=\text{ind}=1}(\mathcal{Y}; \mathcal{N}) \simeq \widehat{\mathcal{M}}_{J'_{f,\delta}}^{I=\text{ind}=1}(\mathcal{Y}; \mathcal{N}),$$

where \simeq indicates a bijection. (If signs were done carefully, they would be preserved by the bijection.) Next, there exists $\epsilon > 0$ small such that J_{f_ϵ} is regular (after possibly perturbing J_f) and there exists $\delta = \delta(\epsilon) > 0$ such that $J'_{f_\epsilon,\delta}$ is close to J_{f_ϵ} and hence is regular and

$$(A-9-3) \quad \widehat{\mathcal{M}}_{J_{f_\epsilon}}^{I=\text{ind}=1}(\mathcal{Y}, e) \simeq \widehat{\mathcal{M}}_{J'_{f_\epsilon,\delta}}^{I=\text{ind}=1}(\mathcal{Y}, e),$$

where e is the negative elliptic orbit obtained by perturbing the Morse–Bott family. Also, for the same $\epsilon > 0$ small, the Morse–Bott gluing theorem in the stable Hamiltonian case (Theorem A.2.1) gives a bijection

$$(A-9-4) \quad \widehat{\mathcal{M}}_{J_f}^{I=\text{ind}=1}(\mathcal{Y}; \mathcal{N}) \simeq \widehat{\mathcal{M}}_{J_{f_\epsilon}}^{I=\text{ind}=1}(\mathcal{Y}, e).$$

Combining (A-9-2), (A-9-3) and (A-9-4) gives

$$(A-9-5) \quad \widehat{\mathcal{M}}_{J'_{f,\delta}}^{I=\text{ind}=1}(\mathcal{Y}; \mathcal{N}) \simeq \widehat{\mathcal{M}}_{J'_{f_\epsilon,\delta}}^{I=\text{ind}=1}(\mathcal{Y}, e)$$

for some $\epsilon > 0$ small and $\delta = \delta(\epsilon) > 0$ small. The difficulty is that we want ϵ to depend on δ , not the other way around.

To remedy this we start with $\epsilon_1 > 0$ small, choose $\delta = \delta(\epsilon_1) > 0$ small such that (A-9-3) holds with $\epsilon = \epsilon_1$, and apply the bifurcation method to the 1-parameter family $\{J'_{f_\epsilon,\delta}\}_{\epsilon \in (0, \epsilon_1]}$. We may assume that $J'_{f_{\epsilon_1},\delta}$ is regular and that $\{J'_{f_\epsilon,\delta}\}_{\epsilon \in (0, \epsilon_1]}$ is regular as a family. By (A-9-2)–(A-9-5), $\widehat{\mathcal{M}}_{J'_{f_{\epsilon_1},\delta}}^{I=\text{ind}=1}(\mathcal{Y}, e)$ consists of a finite number of holomorphic maps (up to translation in the target) that are close to breaking and is in bijection with $\widehat{\mathcal{M}}_{J_f}^{I=\text{ind}=1}(\mathcal{Y}; \mathcal{N})$.

We claim that, for ϵ_1 and δ sufficiently small,

$$\#\widehat{\mathcal{M}}_{J'_{f_\epsilon,\delta}}^{I=\text{ind}=1}(\mathcal{Y}, e) \equiv \#\widehat{\mathcal{M}}_{J'_{f_{\epsilon_1},\delta}}^{I=\text{ind}=1}(\mathcal{Y}, e) \pmod{2}$$

for all $\epsilon \in (0, \epsilon_1]$. To this end we consider the 1-dimensional parametric moduli space which, slightly abusing notation, we denote by $\coprod_{\epsilon \in (0, \epsilon_1]} \widehat{\mathcal{M}}_{J'_{f_\epsilon,\delta}}^{I=\text{ind}=1}(\mathcal{Y}, e)$. Note that the Reeb orbits do not vary as ϵ varies by Lemma A.9.4(2). The claim is a consequence of the following claim: For ϵ_1 and δ small there is no $u_{\bar{\epsilon}} \in \partial(\coprod_{\epsilon \in (0, \epsilon_1]} \widehat{\mathcal{M}}_{J'_{f_\epsilon,\delta}}^{I=\text{ind}=1}(\mathcal{Y}, e))$, where $u_{\bar{\epsilon}}$ is a limit $J'_{f_\epsilon,\delta}$ -holomorphic curve/building for some

$\tilde{\epsilon} \in (0, \epsilon_1)$. Arguing by contradiction, suppose there exist sequences $\{(\delta_i, \tilde{\epsilon}_i)\}_{i=1}^\infty$ and $\{u_{\tilde{\epsilon}_i}\}_{i=1}^\infty$ such that $(\delta_i, \tilde{\epsilon}_i) \rightarrow (0, 0)$ and $u_{\tilde{\epsilon}_i}$ converges to a J_f -holomorphic limit curve u which is

- (i) a 2-level holomorphic building $\tilde{u}_1 \cup \tilde{u}_2$, one of whose components — say \tilde{u}_1 — satisfies $I(\tilde{u}_1) = \text{ind}(\tilde{u}_1) = 0$; or
- (ii) a multiple cover of a holomorphic map \tilde{v} with $I(\tilde{v}) = \text{ind}(\tilde{v}) = 0$;

and neither can occur since u is J_f -holomorphic and J_f is regular. □

Acknowledgements

We are indebted to Michael Hutchings for many helpful conversations and for our previous collaboration, which was a catalyst for the present work. We also thank Dusa McDuff, Ivan Smith, Jean-Yves Welschinger and Chris Wendl for illuminating exchanges. Finally, we thank Michael Hutchings again for pointing out a mistake in the first version of this article, the referees for extensive lists of corrections, and Roman Krutowski for a careful reading of the appendix.

Part of this work was done while Honda and Ghiggini visited MSRI during the academic year 2009–2010. We are extremely grateful to MSRI and the organizers of the *Symplectic and contact geometry and topology* and the *Homology theories of knots and links* programs for their hospitality; this work probably would never have seen the light of day without the large amount of free time which was made possible by the visits to MSRI.

Colin was supported by the Institut Universitaire de France, ANR Symplexe, ANR Floer Power and ERC Géodycon. Ghiggini was supported by ANR Floer Power and ERC Géodycon. Honda was supported by NSF grants DMS-0805352 and DMS-1105432.

Yao acknowledges the support of the Natural Sciences and Engineering Research Council of Canada (NSERC), PGSD3-532405-2019. Cette recherche a été financée par le Conseil de recherches en sciences naturelles et en génie du Canada (CRSNG), PGSD3-532405-2019. Yao would like to thank his advisor Michael Hutchings for constant support. He would also like to thank Alexandru Oancea and Katrin Wehrheim for helpful discussions.

References

- [Bao and Honda 2023] **E Bao, K Honda**, *Semi-global Kuranishi charts and the definition of contact homology*, Adv. Math. 414 (2023) art. id. 108864 MR Zbl
- [Bourgeois 2002] **F Bourgeois**, *A Morse–Bott approach to contact homology*, PhD thesis, Stanford University (2002) Available at <https://www.proquest.com/docview/305591502>
- [Bourgeois 2003] **F Bourgeois**, *A Morse–Bott approach to contact homology*, from “Symplectic and contact topology: interactions and perspectives” (Y Eliashberg, B Khesin, F Lalonde, editors), Fields Inst. Commun. 35, Amer. Math. Soc., Providence, RI (2003) 55–77 MR Zbl

- [Bourgeois and Mohnke 2004] **F Bourgeois, K Mohnke**, *Coherent orientations in symplectic field theory*, Math. Z. 248 (2004) 123–146 MR Zbl
- [Bourgeois et al. 2003] **F Bourgeois, Y Eliashberg, H Hofer, K Wysocki, E Zehnder**, *Compactness results in symplectic field theory*, Geom. Topol. 7 (2003) 799–888 MR Zbl
- [Colin and Honda 2005] **V Colin, K Honda**, *Constructions contrôlées de champs de Reeb et applications*, Geom. Topol. 9 (2005) 2193–2226 MR Zbl
- [Colin and Honda 2013] **V Colin, K Honda**, *Reeb vector fields and open book decompositions*, J. Eur. Math. Soc. 15 (2013) 443–507 MR Zbl
- [Colin et al. 2008] **V Colin, K Honda, F Laudenchbach**, *On the flux of pseudo-Anosov homeomorphisms*, Algebr. Geom. Topol. 8 (2008) 2147–2160 MR Zbl
- [Colin et al. 2011a] **V Colin, P Ghiggini, K Honda**, *Equivalence of Heegaard Floer homology and embedded contact homology via open book decompositions*, Proc. Natl. Acad. Sci. USA 108 (2011) 8100–8105 MR Zbl
- [Colin et al. 2011b] **V Colin, P Ghiggini, K Honda, M Hutchings**, *Sutures and contact homology, I*, Geom. Topol. 15 (2011) 1749–1842 MR Zbl
- [Colin et al. 2024a] **V Colin, P Ghiggini, K Honda**, *The equivalence of Heegaard Floer homology and embedded contact homology via open book decompositions, I*, Publ. Math. Inst. Hautes Études Sci. 139 (2024) 13–187 MR
- [Colin et al. 2024b] **V Colin, P Ghiggini, K Honda**, *The equivalence of Heegaard Floer homology and embedded contact homology via open book decompositions, II*, Publ. Math. Inst. Hautes Études Sci. 139 (2024) 189–348 MR
- [Colin et al. 2024c] **V Colin, P Ghiggini, K Honda**, *The equivalence of Heegaard Floer homology and embedded contact homology, III: From hat to plus*, Publ. Math. Inst. Hautes Études Sci. 139 (2024) 349–385 MR
- [Cristofaro-Gardiner 2013] **D Cristofaro-Gardiner**, *The absolute gradings on embedded contact homology and Seiberg–Witten Floer cohomology*, Algebr. Geom. Topol. 13 (2013) 2239–2260 MR Zbl
- [Dragnev 2004] **DL Dragnev**, *Fredholm theory and transversality for noncompact pseudoholomorphic maps in symplectizations*, Comm. Pure Appl. Math. 57 (2004) 726–763 MR Zbl
- [Eisenbud 1995] **D Eisenbud**, *Commutative algebra: with a view toward algebraic geometry*, Graduate Texts in Math. 150, Springer (1995) MR Zbl
- [Eliashberg et al. 2000] **Y Eliashberg, A Givental, H Hofer**, *Introduction to symplectic field theory*, Geom. Funct. Anal. 2000 (2000) 560–673 MR Zbl
- [Gabai 1983] **D Gabai**, *Foliations and the topology of 3-manifolds*, J. Differential Geom. 18 (1983) 445–503 MR Zbl
- [Giroux 2002] **E Giroux**, *Géométrie de contact: de la dimension trois vers les dimensions supérieures*, from “Proceedings of the International Congress of Mathematicians, II” (T Li, editor), Higher Ed. Press, Beijing (2002) 405–414 MR Zbl
- [Hofer et al. 1995] **H Hofer, K Wysocki, E Zehnder**, *Properties of pseudo-holomorphic curves in symplectisations, II: Embedding controls and algebraic invariants*, Geom. Funct. Anal. 5 (1995) 270–328 MR Zbl
- [Hofer et al. 1996] **H Hofer, K Wysocki, E Zehnder**, *Properties of pseudoholomorphic curves in symplectisation, IV: Asymptotics with degeneracies*, from “Contact and symplectic geometry” (C B Thomas, editor), Publ. Newton Inst. 8, Cambridge Univ. Press (1996) 78–117 MR Zbl
- [Hofer et al. 2003] **H Hofer, K Wysocki, E Zehnder**, *Finite energy foliations of tight three-spheres and Hamiltonian dynamics*, Ann. of Math. 157 (2003) 125–255 MR Zbl

- [Hutchings 2002] **M Hutchings**, *An index inequality for embedded pseudoholomorphic curves in symplectizations*, J. Eur. Math. Soc. 4 (2002) 313–361 MR Zbl
- [Hutchings 2009] **M Hutchings**, *The embedded contact homology index revisited*, from “New perspectives and challenges in symplectic field theory” (M Abreu, F Lalonde, L Polterovich, editors), CRM Proc. Lecture Notes 49, Amer. Math. Soc., Providence, RI (2009) 263–297 MR Zbl
- [Hutchings 2014] **M Hutchings**, *Lecture notes on embedded contact homology*, from “Contact and symplectic topology” (F Bourgeois, V Colin, A Stipsicz, editors), Bolyai Soc. Math. Stud. 26, Bolyai Math. Soc., Budapest (2014) 389–484 MR Zbl
- [Hutchings and Taubes 2007] **M Hutchings, C H Taubes**, *Gluing pseudoholomorphic curves along branched covered cylinders, I*, J. Symplectic Geom. 5 (2007) 43–137 MR Zbl
- [Hutchings and Taubes 2009a] **M Hutchings, C H Taubes**, *Gluing pseudoholomorphic curves along branched covered cylinders, II*, J. Symplectic Geom. 7 (2009) 29–133 MR Zbl
- [Hutchings and Taubes 2009b] **M Hutchings, C H Taubes**, *The Weinstein conjecture for stable Hamiltonian structures*, Geom. Topol. 13 (2009) 901–941 MR Zbl
- [Hutchings and Taubes 2011] **M Hutchings, C H Taubes**, *Proof of the Arnold chord conjecture in three dimensions, I*, Math. Res. Lett. 18 (2011) 295–313 MR Zbl
- [Hutchings and Taubes 2013] **M Hutchings, C H Taubes**, *Proof of the Arnold chord conjecture in three dimensions, II*, Geom. Topol. 17 (2013) 2601–2688 MR Zbl
- [Ivashkovich and Shevchishin 2000] **S Ivashkovich, V Shevchishin**, *Gromov compactness theorem for J -complex curves with boundary*, Int. Math. Res. Not. 2000 (2000) 1167–1206 MR Zbl
- [Juhász 2006] **A Juhász**, *Holomorphic discs and sutured manifolds*, Algebr. Geom. Topol. 6 (2006) 1429–1457 MR Zbl
- [Kronheimer and Mrowka 2007] **P Kronheimer, T Mrowka**, *Monopoles and three-manifolds*, New Math. Monogr. 10, Cambridge Univ. Press (2007) MR Zbl
- [Kutluhan et al. 2020a] **Ç Kutluhan, Y-J Lee, C H Taubes**, *HF = HM, I: Heegaard Floer homology and Seiberg–Witten Floer homology*, Geom. Topol. 24 (2020) 2829–2854 MR Zbl
- [Kutluhan et al. 2020b] **Ç Kutluhan, Y-J Lee, C H Taubes**, *HF = HM, II: Reeb orbits and holomorphic curves for the ech/Heegaard Floer correspondence*, Geom. Topol. 24 (2020) 2855–3012 MR Zbl
- [Kutluhan et al. 2020c] **Ç Kutluhan, Y-J Lee, C H Taubes**, *HF = HM, III: Holomorphic curves and the differential for the ech/Heegaard Floer correspondence*, Geom. Topol. 24 (2020) 3013–3218 MR Zbl
- [Kutluhan et al. 2020d] **Ç Kutluhan, Y-J Lee, C Taubes**, *HF = HM, IV: The Seiberg–Witten Floer homology and ech correspondence*, Geom. Topol. 24 (2020) 3219–3469 MR Zbl
- [Kutluhan et al. 2020e] **Ç Kutluhan, Y-J Lee, C H Taubes**, *HF = HM, V: Seiberg–Witten Floer homology and handle additions*, Geom. Topol. 24 (2020) 3471–3748 MR Zbl
- [Kutluhan et al. 2022] **Ç Kutluhan, S Sivek, C Taubes**, *Sutured ECH is a natural invariant*, Mem. Amer. Math. Soc. 1350, Amer. Math. Soc., Providence, RI (2022) MR Zbl
- [Lang 2002] **S Lang**, *Algebra*, revised 3rd edition, Graduate Texts in Math. 211, Springer (2002) MR Zbl
- [McDuff and Salamon 2004] **D McDuff, D Salamon**, *J-holomorphic curves and symplectic topology*, Amer. Math. Soc. Colloq. Publ. 52, Amer. Math. Soc., Providence, RI (2004) MR Zbl
- [Micallef and White 1995] **M J Micallef, B White**, *The structure of branch points in minimal surfaces and in pseudoholomorphic curves*, Ann. of Math. 141 (1995) 35–85 MR Zbl

- [Morrey 1966] **C B Morrey, Jr.**, *Multiple integrals in the calculus of variations*, Grundle. Math. Wissen. 130, Springer (1966) MR Zbl
- [Ozsváth and Szabó 2004a] **P Ozsváth, Z Szabó**, *Holomorphic disks and topological invariants for closed three-manifolds*, Ann. of Math. 159 (2004) 1027–1158 MR Zbl
- [Ozsváth and Szabó 2004b] **P Ozsváth, Z Szabó**, *Holomorphic disks and three-manifold invariants: properties and applications*, Ann. of Math. 159 (2004) 1159–1245 MR Zbl
- [Taubes 1998] **C H Taubes**, *The structure of pseudo-holomorphic subvarieties for a degenerate almost complex structure and symplectic form on $S^1 \times B^3$* , Geom. Topol. 2 (1998) 221–332 MR Zbl
- [Taubes 2002] **C H Taubes**, *A compendium of pseudoholomorphic beasts in $\mathbb{R} \times (S^1 \times S^2)$* , Geom. Topol. 6 (2002) 657–814 MR Zbl
- [Taubes 2007] **C H Taubes**, *The Seiberg–Witten equations and the Weinstein conjecture*, Geom. Topol. 11 (2007) 2117–2202 MR Zbl
- [Taubes 2010] **C H Taubes**, *Embedded contact homology and Seiberg–Witten Floer cohomology, I*, Geom. Topol. 14 (2010) 2497–2581 MR Zbl
- [Weibel 1994] **C A Weibel**, *An introduction to homological algebra*, Cambridge Stud. Adv. Math. 38, Cambridge Univ. Press (1994) MR Zbl
- [Wendl 2005] **C Wendl**, *Finite energy foliations and surgery on transverse links*, PhD thesis, New York University (2005) Available at <https://www.proquest.com/docview/305467259>
- [Wendl 2008] **C Wendl**, *Finite energy foliations on overtwisted contact manifolds*, Geom. Topol. 12 (2008) 531–616 MR Zbl
- [Wendl 2010] **C Wendl**, *Automatic transversality and orbifolds of punctured holomorphic curves in dimension four*, Comment. Math. Helv. 85 (2010) 347–407 MR Zbl
- [Wendl 2013] **C Wendl**, *A hierarchy of local symplectic filling obstructions for contact 3-manifolds*, Duke Math. J. 162 (2013) 2197–2283 MR Zbl
- [Yao 2022a] **Y Yao**, *Computing embedded contact homology in Morse–Bott settings*, preprint (2022) arXiv 2211.13876
- [Yao 2022b] **Y Yao**, *From cascades to J -holomorphic curves and back*, preprint (2022) arXiv 2206.04334
- [Yau 2007] **M-L Yau**, *A holomorphic 0-surgery model for open books*, Int. Math. Res. Not. 2007 (2007) art. id. rnm041 MR Zbl

VC, PG: *Laboratoire de Mathématiques Jean Leray, Nantes Université
Nantes, France*

Current address for PG: *Institut Fourier, Université Grenoble Alpes
Grenoble, France*

KH: *Department of Mathematics, University of California, Los Angeles
Los Angeles, CA, United States*

YY: *Department of Mathematics, University of California, Berkeley
Berkeley, CA, United States*

vincent.colin@univ-nantes.fr, paolo.ghiggini@univ-grenoble-alpes.fr,
honda@math.ucla.edu, yuan_yao@berkeley.edu
<http://www.math.ucla.edu/~honda>

Proposed: András I Stipsicz
Seconded: Peter Ozsváth, Ciprian Manolescu

Received: 13 April 2020
Revised: 20 August 2023

GEOMETRY & TOPOLOGY

msp.org/gt

MANAGING EDITORS

Robert Lipshitz University of Oregon
lipshitz@uoregon.edu

András I Stipsicz Alfréd Rényi Institute of Mathematics
stipsicz@renyi.hu

BOARD OF EDITORS

Mohammed Abouzaid	Stanford University abouzaid@stanford.edu	Rob Kirby	University of California, Berkeley kirby@math.berkeley.edu
Dan Abramovich	Brown University dan_abramovich@brown.edu	Bruce Kleiner	NYU, Courant Institute bkleiner@cims.nyu.edu
Ian Agol	University of California, Berkeley ianagol@math.berkeley.edu	Sándor Kovács	University of Washington skovacs@uw.edu
Arend Bayer	University of Edinburgh arend.bayer@ed.ac.uk	Urs Lang	ETH Zürich urs.lang@math.ethz.ch
Mark Behrens	University of Notre Dame mbehren1@nd.edu	Marc Levine	Universität Duisburg-Essen marc.levine@uni-due.de
Mladen Bestvina	University of Utah bestvina@math.utah.edu	Jianfeng Lin	Tsinghua University linjian5477@mail.tsinghua.edu.cn
Martin R Bridson	University of Oxford bridson@maths.ox.ac.uk	Ciprian Manolescu	University of California, Los Angeles cm@math.ucla.edu
Tobias H Colding	Massachusetts Institute of Technology colding@math.mit.edu	Haynes Miller	Massachusetts Institute of Technology hrm@math.mit.edu
Simon Donaldson	Imperial College, London s.donaldson@ic.ac.uk	Aaron Naber	Institute for Advanced Studies anaber@ias.edu
Yasha Eliashberg	Stanford University eliash-gt@math.stanford.edu	Peter Ozsváth	Princeton University petero@math.princeton.edu
Benson Farb	University of Chicago farb@math.uchicago.edu	Leonid Polterovich	Tel Aviv University polterov@post.tau.ac.il
David M Fisher	Rice University davidfisher@rice.edu	Colin Rourke	University of Warwick gt@maths.warwick.ac.uk
Mike Freedman	Microsoft Research michaelf@microsoft.com	Roman Sauer	Karlsruhe Institute of Technology roman.sauer@kit.edu
David Gabai	Princeton University gabai@princeton.edu	Stefan Schwede	Universität Bonn schwede@math.uni-bonn.de
Stavros Garoufalidis	Southern U. of Sci. and Tech., China stavros@mpim-bonn.mpg.de	Natasa Sesum	Rutgers University natasas@math.rutgers.edu
Cameron Gordon	University of Texas gordon@math.utexas.edu	Gang Tian	Massachusetts Institute of Technology tian@math.mit.edu
Jesper Grodal	University of Copenhagen jg@math.ku.dk	Nathalie Wahl	University of Copenhagen wahl@math.ku.dk
Misha Gromov	IHÉS and NYU, Courant Institute gromov@ihes.fr	Kirsten Wickelgren	Duke University kirsten.wickelgren@duke.edu
Mark Gross	University of Cambridge mgross@dpms.cam.ac.uk	Anna Wienhard	Universität Heidelberg wienhard@mathi.uni-heidelberg.de

See inside back cover or msp.org/gt for submission instructions.

The subscription price for 2025 is US \$865/year for the electronic version, and \$1210/year (+\$75, if shipping outside the US) for print and electronic. Subscriptions, requests for back issues and changes of subscriber address should be sent to MSP. Geometry & Topology is indexed by Mathematical Reviews, Zentralblatt MATH, Current Mathematical Publications and the Science Citation Index.

Geometry & Topology (ISSN 1465-3060 printed, 1364-0380 electronic) is published 9 times per year and continuously online, by Mathematical Sciences Publishers, 2000 Allston Way # 59, Berkeley, CA 94701-4004. Periodical rate postage paid at Oakland, CA 94615-9651, and additional mailing offices. POSTMASTER: send address changes to Mathematical Sciences Publishers, 2000 Allston Way # 59, Berkeley, CA 94701-4004.

GT peer review and production are managed by EditFLOW[®] from MSP.

PUBLISHED BY

 **mathematical sciences publishers**
nonprofit scientific publishing

<http://msp.org/>

© 2025 Mathematical Sciences Publishers

GEOMETRY & TOPOLOGY

Volume 29 Issue 7 (pages 3345–3919) 2025

Embedded contact homology and open book decompositions	3345
VINCENT COLIN, PAOLO GHIGGINI and KO HONDA	
A landscape of contact manifolds via rational SFT	3465
AGUSTIN MORENO and ZHENGYI ZHOU	
Algebraic models for classifying spaces of fibrations	3567
ALEXANDER BERGLUND and TOMÁŠ ZEMAN	
Resonant forms at zero for dissipative Anosov flows	3635
MIHAJLO CEKIĆ and GABRIEL P PATERNAIN	
Quantisation of derived Poisson structures	3717
JONATHAN P PRIDHAM	
Volume growth of Funk geometry and the flags of polytopes	3773
DMITRY FAIFMAN, CONSTANTIN VERNICOS and CORMAC WALSH	
Invariant prime ideals in equivariant Lazard rings	3813
MARKUS HAUSMANN and LENNART MEIER	
A Weyl's law for singular Riemannian foliations with applications to invariant theory	3873
SAMUEL LIN, RICARDO A E MENDES and MARCO RADESCHI	
The tautological ring of $\overline{\mathcal{M}}_{g,n}$ is rarely Gorenstein	3905
SAMIR CANNING	