

# Detecting tightness via open book decompositions

ANDY WAND

This article is an expository overview of work by the author characterizing tightness of a closed contact 3–manifold in terms of arbitrary open book decompositions thereof. The intent is to provide a “user’s guide” of the theory.

53D10; 57M25, 57R65

## 1 Introduction

As the title indicates, the setting is the world of contact structures on, and open book decompositions of, three-manifolds. Throughout,  $M$  will refer to a smooth, closed, orientable three-manifold, and  $\xi$  a contact structure on  $M$ ; that is to say that  $\xi = \ker(\alpha)$ , where  $\alpha$  is a globally defined 1–form satisfying the condition that  $\alpha \wedge d\alpha$  is a volume form on  $M$ . An *open book decomposition* of  $M$  is a pair  $(B, \pi)$ , where  $B$  is an oriented link embedded in  $M$ , and  $\pi$  a fibration of the complement over  $S^1$ , with the property that each fiber is the interior of a Siefert surface for  $B$ . As is standard in such discussions, we observe that such a decomposition is determined, up to a diffeomorphism of  $M$ , by the topological information of the surface type (the *page*), and the isotopy class of the return map of the fibration (the *monodromy*). In particular then we will denote an open book decomposition by  $(\Sigma, \varphi)$ , where  $\Sigma$  is a surface with boundary, and  $\varphi$  an element of its mapping class group  $\text{MCG}(\Sigma) = \pi_0 \text{Diff}^+(\Sigma, \partial)$ . The relation between these objects is given most completely by the Giroux correspondence theorem:

**Theorem 1.1** (Giroux correspondence [11]) *There is a 1–1 correspondence between the set of contact structures on  $M$  up to isotopy, and the set of open book decompositions of  $M$  up to stabilization.*

The stabilization operation referred to in the above theorem is just the plumbing of a Hopf band to the surface. More precisely:

**Definition 1.2** Let  $(\Sigma, \varphi)$  be an open book decomposition of  $M$ , and  $\alpha$  a properly embedded arc in  $\Sigma$ . Denote by  $\Sigma'$  the result of adding a 1–handle to  $\Sigma$  with attaching

sphere  $\partial\alpha$ , and by  $\tau_s$  the Dehn twist about the simple closed curve  $s$  in  $\Sigma'$  given by extending the core of this handle over  $\alpha$ . Then the pair  $(\Sigma', \tau_s \circ \varphi)$  is an open book decomposition of  $M$ , referred to as a *stabilization* of  $(\Sigma, \varphi)$  (via  $\alpha$ ).

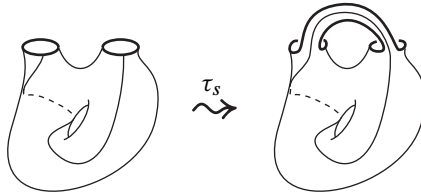

Figure 1: A stabilization

The Giroux correspondence thus reduces the study of contact structures to that of surfaces and mapping classes, though of course this reduction is balanced by the complexity of the stabilization classes. Ideally then, to utilize the correspondence theorem as a classification tool, one would like to understand properties of surface diffeomorphisms in a stabilization-invariant sense; unfortunately most (if not all) previously studied properties (eg the Thurston classification, positive factorizability, right-veering) fail to be stabilization invariant, and as such do not completely characterize any contact property.

For the purpose of this article, the property on the contact side we are interested in detecting is that of *tightness*. Recall that  $\xi$  is called *overtwisted* if there is an embedded disc such that at each point  $p$  on the boundary the tangent plane is just  $\xi_p$ . Otherwise we call  $\xi$  *tight*. The dichotomy between the two is of fundamental import in the field, as, by Eliashberg [5], an overtwisted structure is determined up to isotopy by its homotopy class as a plane field. In particular, if a contact structure is to keep track of any geometric information (a main motivation for their study), it must be tight. As such, it is of interest on the one hand to determine if a given structure is tight, and further to understand how tightness behaves under geometric (Stein/symplectic) cobordisms and so on.

Historically, there are two main directions of approach to the problem, which we may classify as on the one hand using global geometry to obstruct overtwisted discs, and on the other using local topology to detect them. The geometric approach is mainly due to work of Gromov [13], Eliashberg [6], and Giroux, more or less in chronological order of their contributions; the main result is that, if a given mapping class admits a composition into positive Dehn twists, then we may use this factorization to build a Lefschetz fibration of a 4-dimensional Stein domain, such that our 3-fold is the boundary, and our contact structure is given by the complex tangencies, ie  $\xi = TM \cap J(TM)$ . From the previous paragraph, we might hope that such structures, known as *Stein-fillable*,

are not overtwisted, and indeed this is the case. It turns out however that neither of these implications go the other way. In particular, Eliashberg [8] first demonstrated examples of tight structures with no Stein filling, the study of which has since become something of a cottage industry, while in [23] we demonstrated examples of open books which, while supporting Stein fillable structures, admit no positive factorization (similar examples were independently discovered by Baker, Etnyre, and Van Horn-Morris [1]). This latter result can be restated as saying that the property of admitting a positive factorization is *not* stabilization invariant.

The second, “local” approach is due to work of Goodman [12], further generalized through completely different methods (and packaged into its more well-known form) by Honda, Kazez, and Matic [16]. The basic idea here is to generate invariants of the monodromy by considering properly embedded arcs in the surface. In particular, consider the image of such an arc, isotoped to have minimal intersection with the arc; we then have a well defined notion of the arc being *mapped to the right/left* at an endpoint. The main result then is that, if  $\varphi$  maps some arc to the left at some endpoint, then one can cook up an overtwisted disk in the manifold. Again, the opposite implication fails, and in fact it is straightforward to show that any stabilization equivalence class of open book decompositions contains elements in which no arc is mapped to the left (see [16] for an explicit construction).

The main purpose of this paper then is to describe an approach to constructing invariants which uses global data to detect overtwisted discs, and does so in a stabilization-invariant way. In particular, we define a notion of “consistency” for a mapping class (or, equivalently, an open book decomposition), and show:

**Theorem 1.3** [22; 24] *Let  $M$  be a closed 3–manifold,  $\xi$  a contact structure. Then the following are equivalent:*

- (1)  $\xi$  is tight.
- (2) Some open book decomposition supporting  $(M, \xi)$  is consistent.
- (3) Each open book decomposition supporting  $(M, \xi)$  is consistent.

Returning to the connection with 4–dimensional complex/symplectic geometry, a particularly well-motivated view of a contact structure is exactly as the “boundary information” of a Stein/symplectic 4–manifold. Following the advances of Donaldson theory [4] (and later the Seiberg–Witten equations and Taubes’s Gromov invariants; see eg Taubes [21]), there is great interest in understanding cut-and-paste operations in the symplectic/Stein categories. There are indeed contact/symplectic versions of many of the fundamental smooth low-dimensional theorems, particularly concerning surgery

and handle decompositions. For various reasons, the most interesting of these is the case of a (symplectic/Stein) 2–handle attachment. It was shown by Eliashberg [7] and Weinstein [25] that, if the handle is attached along a curve in the contact boundary everywhere tangent to the contact structure, with a framing coefficient one less than that determined by the contact structure, we may extend the geometric structure in a unique way over the handle. The trace of this operation on the contact boundary is referred to as a *Legendrian surgery*, and is a fundamental tool for constructing fillable contact manifolds. Less understood however is the tight/overtwisted dichotomy in this context. Indeed the only known result, due to Honda [15], was an example of an *open* tight contact manifold which becomes overtwisted through Legendrian surgery. Our methods provide tools to fill in this gap, and show that:

**Theorem 1.4** [24] *Tightness of a closed contact 3–manifold is preserved under Legendrian surgery.*

It is worth noting that the assumption that  $M$  be closed is necessary, as Honda demonstrated with specific examples in [15].

The specific aim of this paper is to “unpack” consistency, in particular showing how it can be detected from the data of an arbitrary open book, without reference to the stabilization equivalence class (in contrast with the approach of [24]). As such, the paper should be thought of as a sort of “user’s guide” of the theory. Details of the main theorems will only be sketched, their full forms left to [24] and [22].

**Section 2** is dedicated to introducing the vocabulary of consistency, while in **Section 3** we sketch its main properties, and proofs of the main theoretical applications. **Section 4** describes several explicit constructions used in these proofs. Finally, in **Section 5**, we illustrate the theory with a classification of a family of contact structures given by Legendrian surgery diagrams.

**Acknowledgements** This paper is based on talks given by the author at the conference “Interactions between low dimensional topology and mapping class groups” at the Max Plank Institute for Mathematics in July 2013; we would like to thank the organizers for the opportunity. We would also like to thank the anonymous referees for many helpful comments and suggestions, and John Baldwin for pointing out an error in a previous version.

## 2 Definitions

Let  $(\Sigma, \varphi)$  be an open book decomposition. We will refer to a set  $\Gamma$  of disjoint, (oriented) properly embedded arcs in  $\Sigma$  as an (*oriented*) *arc collection*.

A main object of study in the paper will be “augmented” open books  $(\Sigma, \varphi, \Gamma)$ , for  $\Gamma$  an arc collection. Given oriented arc collection  $\Gamma$ , images of arcs will be given the reverse orientation, while a point  $p$  of  $\Gamma \cap \varphi(\Gamma)$  will be called *positive* if the pair consisting of a tangent vector along the element of  $\Gamma$  at  $p$  followed by that along the image arc gives the usual basis for  $T_p \Sigma$ ; otherwise  $p$  is *negative* (Figure 2). We will assume throughout the paper that we are working with a representative of  $\varphi$  such that each point of  $\partial\Gamma$  is positive, and further that any bigon in  $\Gamma \cup \varphi(\Gamma)$  has a corner in  $\partial\Gamma$  (we refer to such a representative as *right-efficient*).

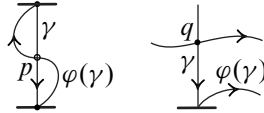

Figure 2: To the left, a right-efficient representative of the identity. Each endpoint of  $\gamma$  is a positive point of intersection, while the point  $p = \text{int } \Sigma \cap \gamma \cap \varphi(\gamma)$  is negative. To the right,  $q$  is positive. This figure introduces the conventions, which will hold throughout the paper, that elements of a given arc collection are drawn as straight lines, their images under a mapping class are curved, and in any figure with multiple line weights, the thickest lines are reserved for  $\partial\Sigma$ .

Our main tool for keeping track of  $\varphi$  will be *regions* in  $(\Sigma, \varphi, \Gamma)$ :

**Definition 2.1** Let  $\Gamma$  be an oriented arc collection in  $(\Sigma, \varphi)$ . A *region* in  $(\Sigma, \varphi, \Gamma)$  is the image of an immersion  $f : D \looparrowright \Sigma$ , where  $D$  is a  $2n$ -gon, whose edges we label  $e_1, e_2, \dots, e_{2n}$  in counter-clockwise order, and such that:

- (1) For  $j$  even,  $f|_{e_j}$  is an embedding to some  $\gamma \in \Gamma$ , while for  $j$  odd,  $f|_{e_j}$  is an embedding to some  $\varphi(\gamma)$ , for  $\gamma \in \Gamma$ .
- (2) Each corner of  $f(D)$  is acute.
- (3) The orientations of  $\Gamma$  and  $\varphi(\Gamma)$  orient  $\partial f(D)$ .

We say that  $\Gamma$  *supports* each such region.

We refer to a region as *positive* if the boundary orientation gotten from its supporting collection agrees with the standard (counter-clockwise) orientation, negative otherwise. Note then that corners alternate in sign as we travel around the boundary of a region. To keep track of these, throughout the paper we will refer to positive corners as  $\bullet$ -points and negative corners as  $\circ$ -points (figures will be decorated accordingly). We will also denote the set of positive (negative) corners of a given region  $A$  as  $\text{Dot}(A)$  ( $\text{Circ}(A)$ ).

We will be interested in a particular sub-collection of regions:

**Definition 2.2** Given  $(\Sigma, \varphi, \Gamma)$  as above, we have nested sequences of sub-collections of regions as follows:

- $\mathcal{R}_0^+(\Gamma) :=$  positive regions with all  $\bullet$ -points on  $\partial\Sigma$ .
- $\mathcal{R}_0^-(\Gamma) :=$  negative regions with all  $\circ$ -points in the  $\circ$ -point set of  $\mathcal{R}_0^+(\Gamma)$ .
- $\mathcal{R}_i^+(\Gamma) :=$  positive regions with all  $\bullet$ -points in  $\partial\Sigma \cup \{\bullet\text{-points of } \bigcup_{j < i} \mathcal{R}_j^-(\Gamma)\}$ .
- $\mathcal{R}_i^-(\Gamma) :=$  negative regions with all  $\circ$ -points in  $\{\circ\text{-points of } \bigcup_{j \leq i} \mathcal{R}_j^+(\Gamma)\}$ .
- $\mathcal{R}^\pm(\Gamma) := \bigcup_i \mathcal{R}_i^\pm(\Gamma)$ .

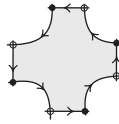

Figure 3: A positive region

We will throughout the paper depending on context use  $\mathcal{R}(\Gamma)$  and  $\mathcal{R}(\Sigma, \varphi, \Gamma)$  to refer to the full collection. Our main object of study will then be certain sub-collections of  $\mathcal{R}(\Gamma)$ , which we refer to as *towers*. To define these, we need the following setup:

**Definition 2.3** Let  $\mathcal{T}^\pm \subset \mathcal{R}^\pm(\Sigma, \varphi, \Gamma)$ , and  $\mathcal{T} := \mathcal{T}^+ \cup \mathcal{T}^-$ . The *graph of  $\mathcal{T}$* , which we denote by  $\mathcal{G}(\mathcal{T})$ , is the abstract directed edge-labeled multigraph (henceforth referred to as an *adem-graph*) whose vertices  $V$  correspond to elements of  $\mathcal{T}^+$ , while for each pair  $A, B \in \mathcal{T}^+$ , each pair  $\{(v \in \text{Dot}(A), y \in \text{Circ}(B)) \mid v, y \text{ are vertices of a common element of } \mathcal{T}^-\}$  gives a distinct edge from  $A$  to  $B$ , labeled by  $v$ . Figure 4 gives examples.

Observe then that edges strictly decrease level, giving a partial order to  $\mathcal{R}^+(\Sigma, \varphi, \Gamma)$ , which extends in the obvious way to  $\mathcal{R}(\Sigma, \varphi, \Gamma)$ . We will use the usual symbols  $<$  and  $>$  throughout to denote this.

**Definition 2.4** A *tower* in  $(\Sigma, \varphi, \Gamma)$  is a collection  $\mathcal{T} \subset \mathcal{R}(\Sigma, \varphi, \Gamma)$  where  $\text{Dot}(\mathcal{T}) \subset (\text{Dot}(\mathcal{T}^-) \cup \partial\Sigma)$ ,  $\text{Circ}(\mathcal{T}) = \text{Circ}(\mathcal{T}^+)$ , and for all pairs  $A, B \in \mathcal{T}$ , no corner of  $A$  is contained in the interior of  $B$ .

We say that  $\Gamma$  *supports*  $\mathcal{T}$ .

**Definition 2.5** A tower  $\mathcal{T}$  is *replete* if whenever  $A \in \mathcal{R}^-(\Gamma)$  satisfies  $\text{Circ}(A) \subset \text{Circ}(\mathcal{T})$ , and  $\mathcal{T} \cup \{A\}$  is again a tower, then  $A \in \mathcal{T}$ . Throughout the paper, all towers will be assumed replete.

**Definition 2.6** Let  $\mathcal{G} = (V, E)$  be an adem-graph, and  $s$  a section of the equivalence relation generated by the labeling. Then the adem-graph  $\mathcal{G}^s := (V, s(E))$  is a *skeleton* of  $\mathcal{G}$ .

**Definition 2.7** A tower  $\mathcal{T}$  is *independently supported* if each skeleton of  $\mathcal{G}(\mathcal{T})$  is a tree.

**Definition 2.8** A tower  $\mathcal{T}$  is *completed* if it contains some maximal negative region  $A$ ; equivalently, one which shares no  $\bullet$ -point with any element of  $\mathcal{T}^+$ . Otherwise,  $\mathcal{T}$  is *incomplete*.

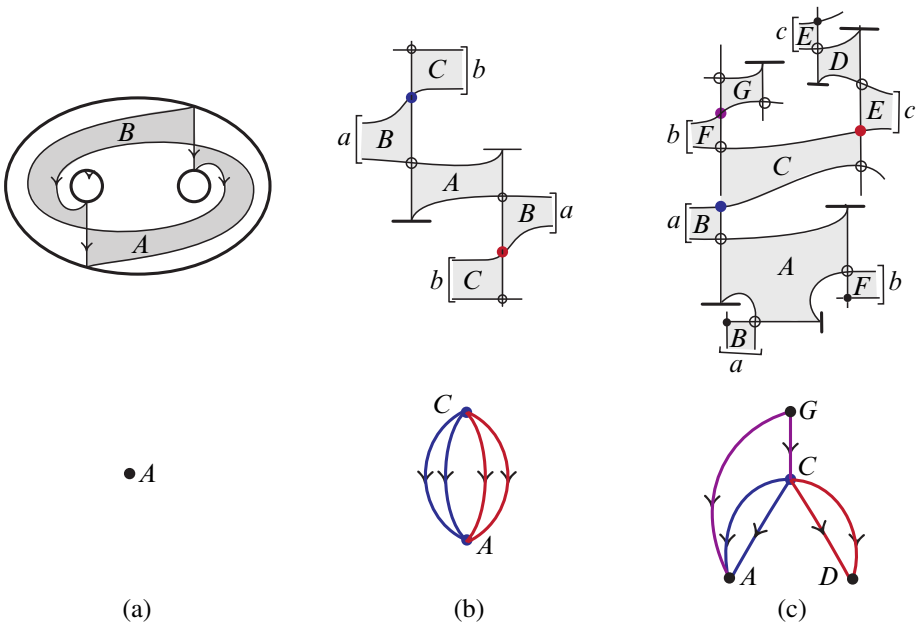

Figure 4: (a) A simple tower containing a single positive region, which is completed. (b) A tower which is not independently supported. (c) An independently supported, incomplete tower. In each figure, edge labelings are by color, so that if edge  $e$  is labeled by  $\bullet$ -point  $v$ , then  $v$  and  $e$  are illustrated with the same color.

**Definition 2.9** Let  $(\Sigma, \varphi)$  be an open book decomposition. We say an oriented arc collection  $\Gamma$  is *consistent* in  $(\Sigma, \varphi)$  if each independently supported tower in  $(\Sigma, \varphi, \Gamma)$  is completed.

Our characterization of tightness ([Theorem 1.3](#)) then takes the following form (compare with [\[24, Definition 2.6\]](#)):

**Definition 2.10** A class  $\varphi \in \text{MCG}(\Sigma)$  is *inconsistent* if there is some inconsistent arc collection  $\Gamma$  in  $(\Sigma, \varphi)$ . Otherwise,  $\varphi$  is *consistent*.

### 3 Properties of consistency

The purpose of this section is sketch the arguments required for the proof of [Theorem 1.3](#). Throughout the section, a *basis* of a surface will refer to an arc collection which cuts the surface into a disc, while an arc collection  $\Gamma$  will be said to be *guided* by a basis  $\mathcal{B}$  if each element of  $\Gamma$  is isotopic to one of  $\mathcal{B}$  (note that the definition allows parallel arcs of distinct orientations). The central idea then is to show that consistency of a mapping class is determined by any basis of the surface. We will make use of the following set-up (see eg [\[17\]](#)):

**Definition 3.1** Let  $\gamma_a$  and  $\gamma_b$  be elements of some arc collection  $\Gamma$  in surface  $\Sigma$ , and  $\sigma$  some arc in  $\partial\Sigma$  connecting an endpoint of  $\gamma_a$  to an endpoint of  $\gamma_b$ , and such that  $\sigma$  has no interior intersection with  $\Gamma$ . Then the pair  $\gamma_a, \gamma_b$  is *summable*, while a properly embedded arc in the isotopy class of  $\gamma_a \cup \sigma \cup \gamma_b$  is referred to as a *sum* of  $\gamma_a$  and  $\gamma_b$ .

**Definition 3.2** Let  $\Gamma$  be an arc collection,  $\gamma_a, \gamma_b \in \Gamma$  a summable pair. Then the operation on  $\Gamma$  consisting of removing  $\gamma_a$ , and adding in a sum of  $\gamma_a$  and  $\gamma_b$ , is an *arc slide* ([Figure 5](#)).

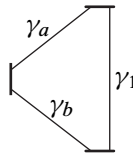

Figure 5:  $\{\gamma_1, \gamma_a\} \rightsquigarrow \{\gamma_1, \gamma_b\}$  is an arc slide

The main result we require is the following:

**Lemma 3.3** [\[17\]](#) Any two bases of a given surface are related by arc slides.

In particular then, we want to show that consistency is preserved by an arc slide:

**Lemma 3.4** Let  $\mathcal{B}_1$  and  $\mathcal{B}_2$  be bases of  $\Sigma$ , related by a single arc-slide. Then  $\mathcal{B}_1$  guides an inconsistent arc collection if and only if  $\mathcal{B}_2$  guides an inconsistent arc collection.



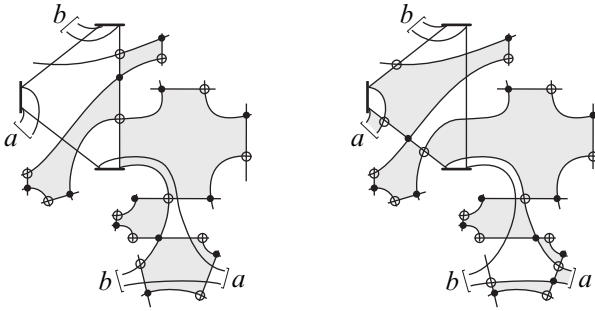

Figure 6

While Lemma 3.4 does admit a fairly intuitive direct proof, which essentially consists of “pushing” a given tower in  $\mathcal{B}_1$  over an arc-slide domain, so (using the notation of Figure 5) replace  $\gamma_1$  with the pair  $\gamma_a$  and  $\gamma_b$  to obtain a tower in  $\mathcal{B}_2$  (Figure 6), and then verifying that the operation preserves the properties of independent support and incompleteness, the combinatorics are quite tricky, and require one to consider a large number of cases. Accordingly, we will take something of a short-cut by invoking some terminology and results from [24].

**Definition 3.5** Let  $P$  be some property of augmented open book decompositions. Then, given an augmented open book  $(\Sigma, \varphi, \Gamma)$ , we say that  $(\Sigma, \varphi, \Gamma)$  *stably* satisfies  $P$  if there is some sequence of positive stabilizations after which the stabilized triple  $(\Sigma', \varphi', \iota(\Gamma))$  satisfies  $P$  (where  $\iota$  is the obvious inclusion of properly embedded arcs of  $\Sigma$  into those of  $\Sigma'$ ).

We have:

**Definition 3.6** An arc collection  $\Gamma$  is *boundary inconsistent* in  $(\Sigma, \varphi)$  if  $\mathcal{R}(\Sigma, \varphi, \Gamma)$  contains some tower consisting of a single (necessarily positive), embedded, region  $A$ , and further  $\text{int } \Sigma \cap \Gamma \cap \varphi(\Gamma) = \text{Circ}(A)$  (such a region is referred to as an “overtwisted region” in [24]).

**Observation 3.7** The reader familiar with the combinatorial versions of Heegaard–Floer homology will likely notice that existence of such a region implies vanishing of the Heegaard–Floer “contact class”, and that more generally the regions we are considering throughout the paper are essentially just those corresponding to genus-0 regions contributing to the differential. As such, one may think of Heegaard–Floer theory as giving a model for an “algebraization” (and generalization) of consistency; this is the subject of work in progress.

We then have a “stable” version of [Lemma 3.4](#):

**Lemma 3.8** [24] *Stable boundary inconsistency is detected in any basis; ie if some basis of  $\Sigma$  guides a stably boundary inconsistent arc collection in  $(\Sigma, \varphi)$ , then so does any other basis.*

**Sketch of proof** Again, using [Lemma 3.3](#), it is clearly sufficient to consider a pair of bases  $\mathcal{B}_1$  and  $\mathcal{B}_2$  related by a single arc slide  $\{\gamma_1, \gamma_2\} \rightsquigarrow \{\gamma_2, \gamma_3\}$ . Let  $\Gamma$  be a stably boundary inconsistent arc collection guided by  $\mathcal{B}_1$ . There is then a sequence of stabilizations, and inclusion map  $\iota$ , such that  $\iota(\Gamma)$  is boundary inconsistent in the stabilized open book decomposition. One then observes that we may replace each element  $\gamma'_1$  of  $\Gamma$  isotopic to  $\gamma_1$  by a pair  $\gamma'_2$  and  $\gamma'_3$ , isotopic to  $\gamma_2$  and  $\gamma_3$ , in such a way that  $\{\iota(\gamma'_1), \iota(\gamma'_2)\} \rightsquigarrow \{\iota(\gamma'_2), \iota(\gamma'_3)\}$  is again an arc-slide (in the stabilized open book decomposition). As such, we have reduced the problem to the case of a single arc-slide in the stabilized book, in which our tower has the particularly simple form of [Definition 3.6](#). It remains only to verify that such a region can always be “pushed” over an arc-slide domain to another such region. We refer to [24] for details.  $\square$

[Lemma 3.4](#) then follows by showing that stable boundary inconsistency is equivalent to consistency.

**Lemma 3.9** *Let  $(\Sigma, \varphi, \Gamma)$  be an augmented open book decomposition. Then  $\Gamma$  is stably boundary inconsistent if and only if  $\Gamma$  is inconsistent (in  $(\Sigma, \varphi)$ ).*

**Sketch of proof** The “if” direction is by far the most combinatorially intensive argument of the paper; as such it is deferred to the next section. The “only if” part of the argument then consists of showing that an incomplete, independently supported tower is “preserved” by destabilization.  $\square$

### 3.1 Tightness

We now have the tools to prove [Theorem 1.3](#), whose statement we recall below. The proof is a slight adaptation of that given in [24], reflecting the slightly different focus of this paper.

**Theorem 1.3** *Let  $M$  be a closed 3–manifold,  $\xi$  a contact structure. Then the following are equivalent:*

- (1)  $\xi$  is tight.
- (2) Some open book decomposition supporting  $(M, \xi)$  is consistent.
- (3) Each open book decomposition supporting  $(M, \xi)$  is consistent.

**Proof** We begin with the equivalence of (2) and (3). Let  $(\Sigma, \varphi) \rightsquigarrow (\Sigma', \varphi')$  be a stabilization via properly embedded arc  $\alpha$ . Following the notation set up in the introduction,  $\varphi' = \tau_s \circ \varphi$ , where  $s$  is the extension over  $\alpha$  of the core of the stabilizing 1–handle. Let  $\mathcal{B}$  denote a basis for  $\Sigma$  with the property that  $\varphi(\mathcal{B}) \cap \alpha = \emptyset$  (for example, building a handle decomposition of  $\Sigma$  in which the unique 0–handle is given by a neighborhood of  $\alpha$ , the set of co-cores of the 1–handles gives a basis  $\mathcal{C}$  such that  $\mathcal{C} \cap \alpha = \emptyset$ ; setting  $\mathcal{B} = \varphi^{-1}\mathcal{C}$  then satisfies our requirement). We claim then that  $\mathcal{R}(\Sigma, \varphi, \mathcal{B}) = \mathcal{R}(\Sigma', \varphi', \mathcal{B}')$ , where  $\mathcal{B}'$  is obtained by adding the co-core  $\gamma_s$  of the stabilizing 1–handle to (the obvious inclusion of)  $\mathcal{B}$ . To see this, note firstly that our condition on  $\mathcal{B}$  gives an identification  $\mathcal{R}(\Sigma, \varphi, \mathcal{B}) = \mathcal{R}(\Sigma', \varphi', \mathcal{B})$ . On the other hand,  $\gamma_s \cap \tau_s(\varphi(\gamma)) = \emptyset$  for each  $\gamma \in \mathcal{B}$ , so  $\mathcal{R}(\Sigma', \varphi', \mathcal{B}')$  contains no regions with edge along  $\gamma_s$  or its image. The result then follows from [Lemma 3.4](#).

To see that (2) implies (1), suppose that  $\xi$  is overtwisted. Using Eliashberg’s homotopy classification of overtwisted contact structures [\[5\]](#) it is straightforward to find an open book decomposition  $(\Sigma, \varphi)$  supporting  $\xi$  which is a negative stabilization (ie replace the Dehn twist in [Definition 1.2](#) with its inverse) of some other open book (see [\[12\]](#) or [\[16\]](#) for a proof). In particular, a right-efficient representative determines a pair of level-0, incomplete bigon regions supported by the co-core  $\gamma$  of the stabilization handle. In particular then any basis containing  $\gamma$  detects inconsistency.

Finally, to see that (1) implies (2), we generalize a construction due to Goodman [\[12\]](#) to demonstrate an overtwisted disc in  $(M, \xi)$  whenever a supporting triple  $(\Sigma, \varphi, \Gamma)$  has an overtwisted region ([Definition 3.6](#)); using [Lemma 3.9](#), the result follows. In particular, suppose  $A$  is such a region, supported by  $\Gamma = \{\gamma_1, \gamma_2, \dots, \gamma_n\}$ , where  $\gamma_i \cap \varphi(\gamma_j)$  is a corner for  $A$  for  $i < n$  and  $j = i + 1$ , or  $i = n$  and  $j = 1$ . We then consider the suspension  $S_i$  of  $\gamma_i$  in the mapping torus of  $(\Sigma, \varphi)$ , which we extend over the binding by attaching a meridional disc along each  $\{p\} \times S^1$ , for  $p \in \partial\gamma_i$ . We thus have a collection of embedded discs (one for each element of  $\Gamma$ ) which we label  $D_i$ , and  $n$  positive boundary-intersection points  $\partial D_{i < n} \cap \partial D_{i+1}$  and  $\partial D_n \cap \partial D_1$ . We then “resolve”  $\bigcup_i D_i$  at each intersection point  $p$  by adding a pair of small triangles from the page  $\Sigma$  through  $p$  in the unique way which preserves the boundary orientation. Smoothing the result via an isotopy relative to the boundary, and then pushing each  $\partial\gamma_i$  into  $\Sigma$ , we obtain an embedded annulus  $C \looparrowright M$ , such that the boundary is contained in  $\Sigma$ , and exactly one boundary component of  $C$  bounds a disc in  $\Sigma$ . Finally, then, “capping off” a boundary component of  $C$  via this disc, we obtain a disc  $D$ ; following the arguments of Goodman, which in turn rely on the “Legendrian realization principle” of Honda [\[14\]](#), we may make  $\partial D$  Legendrian. Moreover, the Thurston–Bennequin number of  $\partial D$  is just given by the intersection of  $D$  with a push-off of the boundary along  $\Sigma$ , so is zero. We conclude that  $D$  is an overtwisted disc.

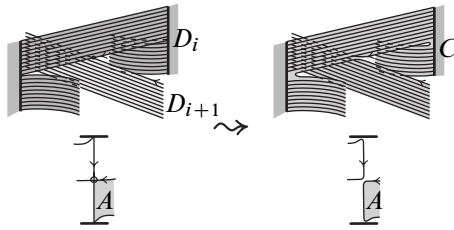

Figure 7: To the left: above, the discs  $D_i$  and  $D_{i+1}$ , in a neighborhood of  $\gamma_i$ , illustrating the foliation of the mapping torus by the pages; below, the restriction to  $\Sigma \times \{0\}$  in the mapping torus  $\Sigma \times [0, 1]/(p, 1) \sim (\varphi(p), 0)$ . To the right, the result  $C$  of resolving the intersections.

Alternatively, one can simply observe that, assuming  $A$  is at least an  $(n > 2)$ -gon, each element of  $\Gamma$  is in fact the co-core of a stabilizing handle, and moreover that, destabilizing  $(\Sigma, \varphi)$  via any such handle has the effect of turning  $A$  into an  $(n-2)$ -gon, again incomplete, and isolated. Thus, by repeating the process we may assume  $A$  is a bigon, at which point the right-veering criterion of [16] implies overtwistedness.  $\square$

## 3.2 Applications

Besides the obvious utility of [Theorem 1.3](#) as a straightforward classification tool, it may of course also be used to generate sufficient conditions for tightness in the language of more standard frameworks. We gather two such applications in this section.

**Theorem 3.10** [22] *Let  $(M, \xi)$  be supported by an open book decomposition with the property that the fractional Dehn twist coefficient about each boundary component is greater than 1. Then  $\xi$  is tight.*

**Sketch of proof** Let  $(\Sigma, \varphi)$  be such an open book decomposition. Rather than defining the fractional Dehn twist coefficient (see eg [16]), we simply note that our condition implies that, for each arc  $\gamma$  in  $\Sigma$ , and each endpoint  $x$  of  $\gamma$ , the image  $\varphi(\gamma)$  twists at least once around the boundary component containing  $x$  ([Figure 8](#)) (as usual assuming right-efficiency). One may then verify that for any  $\Gamma$  guided by a basis,  $\mathcal{R}_i(\Sigma, \varphi, \Gamma)$  is empty for  $i > 0$ , and any positive elements of  $\mathcal{R}_0$  are completed, so  $\varphi$  is consistent. As an aside, this conclusion does *not* hold under the weaker assumption that a *given*  $\Gamma$  is such that for each arc  $\gamma$  in  $\Gamma$ , and each endpoint  $x$  of  $\gamma$ , the image  $\varphi(\gamma)$  twists at least once around the boundary component containing  $x$ .  $\square$

It should be noted that [Theorem 3.10](#) was previously known for the case of an open book decomposition whose pages have a single boundary component by Colin and

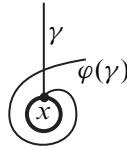

Figure 8

Honda [2], and later independently shown by Ito and Kawamuro [18] to hold under the added restriction that the open book decomposition have *planar* pages.

**Theorem 1.4** [24] *Let  $(M, \xi)$  be a tight, closed, contact 3–fold,  $L$  a Legendrian knot in  $(M, \xi)$ , and  $(M', \xi')$  the result of performing Legendrian surgery on  $L$ . Then  $(M', \xi')$  is tight.*

**Sketch of proof** It follows from work of Giroux (see eg [9]) that, if  $L$  is a Legendrian knot in contact  $(M, \xi)$ , then one may find an open book  $(\Sigma, \varphi)$  supporting  $(M, \xi)$  such that  $L$  is a homologically non-trivial curve on a page, and furthermore the contact manifold  $(M', \xi')$  obtained by Legendrian surgery along  $L$  is supported by  $(\Sigma, \tau_L \circ \varphi)$ . As such, in light of Theorem 1.3, it is sufficient to show that, whenever  $(\Sigma, \varphi)$  is inconsistent, and  $L$  homologically non-trivial in  $\Sigma$ , then  $(\Sigma, \tau_L^{-1} \varphi)$  is again inconsistent.

The verification of this is simplified greatly by the observation that we may chose a basis  $\mathcal{B}$  of  $\Sigma$  with the property that  $L$  has non-trivial intersection with exactly one element of  $\varphi(\mathcal{B})$ , which we label  $\varphi(\gamma)$ , and further that it intersects  $\varphi(\gamma)$  exactly once. Using this, along with Lemma 3.9, it follows that we may assume our open book contains an incomplete level-0 positive region (i.e one in  $\mathcal{R}_0^+$ ), which has no intersection with  $L$ . The region then again is boundary based in  $(\Sigma, \tau_L^{-1} \varphi)$ , while the assumptions on  $L$  allow one to conclude incompleteness.  $\square$

## 4 Overtwisted discs from incomplete towers

In this section, we sketch an algorithm from [22] for stabilizing an inconsistent arc collection into a boundary inconsistent collection (so finishing the “if” direction of Lemma 3.9). Our construction has two main pieces. We will show that:

**Lemma 4.1** (Tower reduction) *If  $(\Sigma, \varphi, \Gamma)$  is inconsistent, then  $(\Sigma, \varphi, \Gamma)$  stably supports an incomplete tower with a single element.*

**Lemma 4.2** (Intersection reduction) *If  $(\Sigma, \varphi, \Gamma)$  stably supports an incomplete tower with a single element, then stably, each interior point of  $\Gamma \cap \varphi(\Gamma)$  is a negative corner in the tower.*

### 4.1 Tower reduction

Our goal is to “simplify” a given tower through stabilizations. We have:

**Definition 4.3** Let  $\mathcal{T}$  be a tower. Let  $c_1(\mathcal{T})$  denote the number of positive regions of  $\mathcal{T}$  with at least one corner on  $\partial\Sigma$ , and  $c_2(\mathcal{T}) := \min\{j \mid \mathcal{T}_0^- \text{ contains a } j\text{-gon}\}$  (for the case that  $\mathcal{T}_0^- = \emptyset$ , we set  $c_2(\mathcal{T}) = 0$ ). Then the *complexity* of  $\mathcal{T}$ , denoted  $c(\mathcal{T})$ , is the pair  $(c_1(\mathcal{T}), c_2(\mathcal{T}))$ . Similarly, for inconsistent  $\varphi \in \text{MCG}(\Sigma)$ , we define  $c(\varphi)$  to be the minimal (under the lexicographical order) value of  $c(\mathcal{T})$  over all independently supported incomplete towers in  $\mathcal{R}(\Sigma, \varphi, \Gamma)$ .

To prove Lemma 4.1, then, it is sufficient to show that, given inconsistent  $\varphi$ , we may always find a stabilization such that the stabilized class has smaller complexity; it follows that we may always find a class with complexity  $(1, 0)$ , which is the minimal possible value, and implies the conclusion of the lemma.

In defining stabilization arcs, a basic construction we will make use of throughout the sub-section is the following:

**Definition 4.4** Let  $A$  be a region in  $(\Sigma, \varphi, \Gamma)$ , and let  $D$  denote the polygon domain of  $A$ , so  $A = f(D)$  for some immersion  $f$ . Let  $x_1$  and  $x_2$  denote corners of  $A$ , and let  $y_i$  denote the pre-image of  $x_i$  for each  $i$ . Finally, let  $\rho_{y_1, y_2}$  denote a representative of the unique isotopy class of arcs in  $D$  from  $y_1$  to  $y_2$ . Then the image  $f(\rho_{y_1, y_2})$  is a *chord* of  $A$ , which we denote  $[x_1, x_2]_A$  (Figure 9).

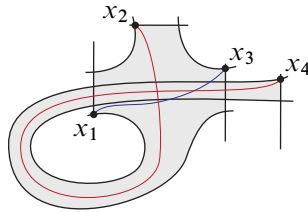

Figure 9: An immersed region, with and chords  $[x_1, x_3]$  and  $[x_2, x_4]$

We will go through the proof for an *embedded* tower, and then sketch the general case (here *embedded* simply means that regions intersect only in corners). As such, let  $\mathcal{T}$  be an embedded independently supported incomplete tower with  $c(\mathcal{T}) > (1, 0)$ , and  $B$  in  $\mathcal{T}_0^-$  a  $c_2(\mathcal{T})$ -gon. As  $\mathcal{T}$  is incomplete, there are then  $A \in \mathcal{T}_1^+$  and  $C \in \mathcal{T}_0^+$  such that  $A > B > C$ . Assume for the moment that  $A$  has some corner on  $\partial\Sigma$ . Then, for any triple  $(x, v, y)$ , where  $x \in \text{Dot}(A) \cap \partial\Sigma$ ,  $v \in \text{Dot}(A) \cap \text{Dot}(B)$ , and  $y \in \text{Circ}(B) \cap \text{Circ}(C)$ , we define a pair of arcs in  $\Sigma$  as follows (Figure 10):

- Let  $\sigma_1$  denote the arc obtained by extending  $[x, v]_A \cup_v [v, y]_B$  in  $\varphi(\Gamma) \cap \partial A$  to  $\partial \Sigma$ , isotoped to intersect the restriction of  $\varphi(\Gamma)$  to the boundaries of  $A$ ,  $B$  and  $C$  in exactly 2 points, each in  $\partial A$ .
- Let  $\sigma_2$  denote the arc obtained by extending  $[x, v]_A \cup_v [v, y]_B$  in  $\Gamma \cap \partial A$  to  $\partial \Sigma$ , isotoped to intersect the restriction of  $\varphi(\Gamma)$  to the boundaries of  $A$ ,  $B$  and  $C$  in exactly 2 points, each in  $\partial B$ .

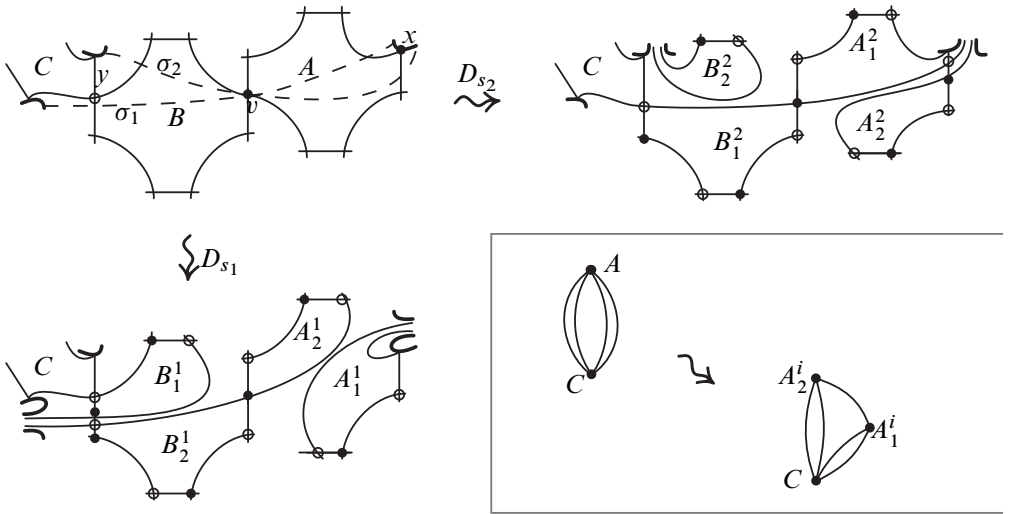

Figure 10

Consider then the corresponding stabilizations, with twists  $\tau_{s_1}$  and  $\tau_{s_2}$ . Letting  $D_{s_i}$  denote a representative of  $\tau_{s_i}$  supported in a neighborhood of  $s_i$ , each diffeomorphism  $D_{s_i}$  is then the identity on  $\mathcal{T}$  away from  $\{A, B\}$ . Moreover,  $\Gamma|_{\{A, B\}}$  and  $D_{s_i}(\varphi(\Gamma)|_{\{A, B\}})$  bound a chain of 4 regions, which we label  $\{A_1^i, A_2^i, B_1^i, B_2^i\}$ , such that  $A_2^i > B_2^i > A_1^i > B_1^i$  (Figure 10 illustrates the regions, and also the effect on the graph of the tower). Note that, as each corner of  $A$ ,  $B$  and  $C$  other than  $v$  and  $y$  is again a corner of the new collection, we have a new tower in the image, which we label  $D_{s_i}(\mathcal{T})$ . Clearly,  $\mathcal{G}(D_{s_i}(\mathcal{T}))$  differs from  $\mathcal{G}(\mathcal{T})$  by the local modification illustrated in Figure 10, so in particular is again independently supported and incomplete. Finally, we let  $\mathcal{T}_i$  denote the image of  $D_{s_i}(\mathcal{T})$  under a right-efficient isotopy of  $D_{s_i}(\varphi(\Gamma))$ .

We then leave as an exercise the following verifications:

- $A_1^i$  is not a bigon; as such, if  $B_1^i$  is a bigon, the right efficient isotopy “merges”  $C$  and  $A_1^i$ , so that  $c_1(\mathcal{T}_i) < c_1(\mathcal{T})$ .
- If neither  $B_1^i$  is a bigon, then  $c_1(\mathcal{T}_i) = c_1(\mathcal{T})$ . However, at least one of the  $B_1^i$  has fewer sides than  $B$ , so that  $c_2(\mathcal{T}_i) < c_2(\mathcal{T})$ .

The case that  $A$  has no corner on  $\partial\Sigma$  is a straightforward modification; we illustrate the relevant arcs and stabilizations with [Figure 11](#).

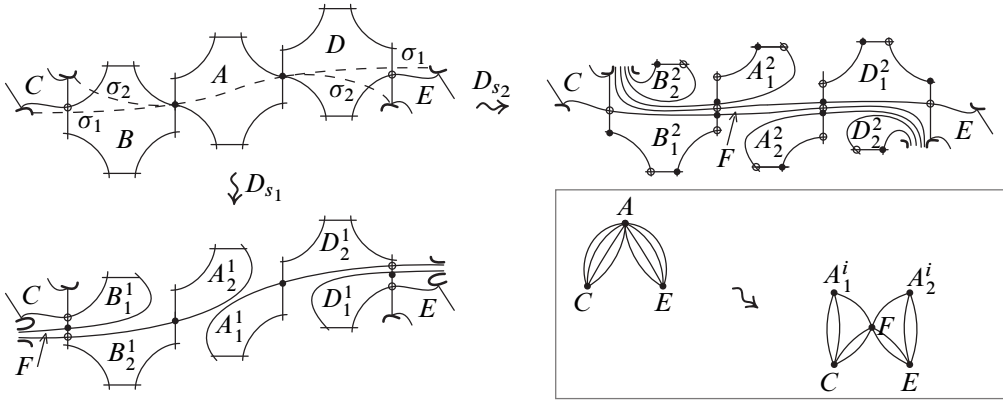

Figure 11

Of course this construction depends heavily on our assumption that  $\mathcal{T}$  is embedded; we sketch the steps involved in the more general case:

- Let  $A \in \mathcal{R}(\Sigma, \varphi, \Gamma)$ , and  $v \in \text{Dot}(A)$ . Then there is  $v' \in \text{Dot}(A)$  such that  $[v, v']_A$  is embedded.
- As such, for any  $A \in \mathcal{T}_0^+$ , one may always find an embedded chord with endpoints on  $\partial\Sigma$ .
- Isotoping such a chord so as to intersect  $\partial A$  in two points, both either in  $\Gamma$  or  $\varphi(\Gamma)$ , we have a stabilization arc which preserves  $\mathcal{G}(\mathcal{T})$ .
- Using such stabilizations, one may “empty”  $\mathcal{T}_0^+$ ; ie stably,  $\forall A \in \mathcal{T}_0^+$ ,  $\text{int}(A) \cap (\Gamma \cup \varphi(\Gamma)) = \emptyset$ .

Now, let  $A \in \mathcal{T}_1^+$ , and  $v \in \text{Dot}(A)$  be 2-sided, so there is  $B \in \mathcal{T}_0^-$  incident to  $A$  at  $v$ . Then one may find:

- $v' \in \text{Dot}(A)$  such that  $[v, v']_A$  is embedded.
- $y \in \text{Circ}(B)$  such that  $[y, v]_B \cup_{\{v\}} [v, v']_A$  is embedded.

So, if  $v \in \partial\Sigma$ , we have an extension of  $[y, v]_B \cup_{\{v\}} [v, v']_A$  to a complexity-reducing stabilization arc of either of the types illustrated in [Figure 10](#). Otherwise, we may repeat the same argument to extend over some region  $D \in \mathcal{T}_0^-$  incident to  $A$  at  $v'$ , and then to a complexity-reducing stabilization arc of either of the types illustrated in



**Figure 11.** It remains then to verify that core stabilizations in the general case have the same effect on complexity as in the embedded case. This statement has a “local” component (that complexity of the local collection  $\{A, B, C\}$  (resp.  $\{A, B, C, D, E\}$ ) is reduced), and a “global” component (that complexity is not increased away from the local collection). We leave these verifications to [22].

### 4.2 Intersection reduction

Let  $A$  be a level-0, incomplete region in some  $(\Sigma, \varphi, \Gamma)$ , where  $\Gamma$  is “minimal” in the sense that each element  $\gamma \in \Gamma$  contains an edge of  $A$ . Using the results of the previous sub-section, we may (and will) assume that  $A$  is “empty”; ie  $\text{int}(A) \cap (\Gamma \cup \varphi(\Gamma)) = \emptyset$ . The goal of this sub-section is to show that  $A$  is stably *isolated* in the sense of [24]; ie such that each intersection  $\text{int} \Sigma \cap \Gamma \cap \varphi(\Gamma)$  is a corner of  $A$ .

We will recall a bit of helpful machinery from [23]:

**Definition 4.5** Let  $\sigma$  be a arc or simple closed curve in  $\Sigma$ ,  $(\Sigma, \varphi, \Gamma)$  an augmented open book. An *upward triangle* in  $(\Sigma, \varphi, \Gamma)$  (with respect to  $\sigma$ ) is the image of an immersion of a triangle  $T$  in  $\Sigma$ , such that the edges of  $T$  are mapped into  $\Gamma, \sigma$ , and  $\varphi(\Gamma)$  respectively, in counter-clockwise order about  $T$  (Figure 12). Any vertex of an upward triangle is referred to as *upward*.

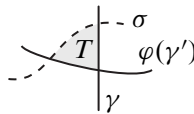

Figure 12

Now, let  $\tau_s$  be the Dehn twist associated to a stabilization of  $(\Sigma, \varphi)$ . We factor a representative of  $\tau_s$  as  $I_s \circ D_s$ , for  $D_s$  a twist diffeomorphism supported in a neighborhood of  $s$ , and  $I_s$  a right-efficient isotopy of  $D_s(\varphi(\Gamma))$ . It is not difficult to see (and is shown explicitly in [23]) that the set of upward triangles is in 1–1 correspondence with interior bigons in  $\Gamma$  and  $D_s(\varphi(\Gamma))$  (Figure 13(a)–(b)). Thus  $I_s$  may be taken to be a sequence of isotopies over such bigons (Figure 13(b)–(c)).

Suppose then that  $\gamma \in \Gamma$  is such that  $\#|s \cap \gamma| = 1$ . Thus each upward point of  $\gamma \cap \varphi(\Gamma)$  is in a unique bigon of  $\gamma \cup D_s(\varphi(\Gamma))$ , so the isotopy  $I_s$  removes two points of  $\gamma \cap D_s(\varphi(\Gamma))$  for each such upward point. In other words, letting  $t$  denote the number of upward points of  $\gamma \cap \varphi(\Gamma)$ , we have

$$(1) \quad 2t - \#|s \cap \varphi(\Gamma)| = \#|\gamma \cap \varphi(\Gamma)| - \#|\gamma \cap \tau_s(\varphi(\Gamma))|.$$

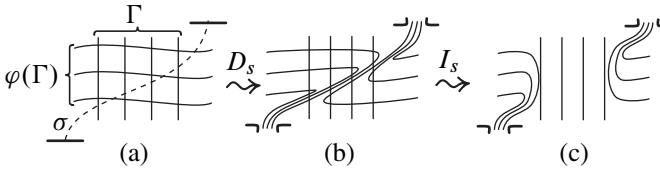

Figure 13

We will refer to the left side of (1) as the *reduction* (along  $\gamma$ ) associated to  $\tau_s$ .

We pause to gather some notation, to be used throughout the remainder of the subsection. Letting  $\gamma$  be an element of  $\Gamma$ , we label the points  $\gamma \cap \varphi(\Gamma) \cap \text{int}(\Sigma)$  by  $X := \{x_i\}_{i=0}^n$ , such that indices decrease along the orientation of  $\gamma$ . Then for each  $i < n$ , let  $e_i$  denote the segment of  $\gamma$  from  $x_i$  to  $x_{i+1}$ , and  $\rho_i$  the sub-arc of  $\varphi(\Gamma)$  to the right of  $x_i$  up to its next intersection with either  $\gamma$  or  $\partial\Sigma$ . Finally, cutting  $\Sigma$  along  $\gamma$  and each  $\rho_i$ , label the component to the right of  $e_i$  by  $R_i$  (note that these labels are not necessarily unique).

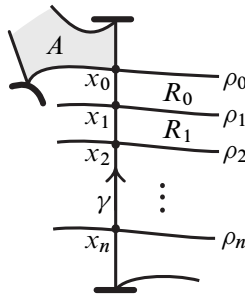

Figure 14

We will also make use of a simple construction for producing properly embedded arcs: Let  $\Sigma'$  denote the result of cutting  $\Sigma$  along  $\gamma$ , and  $\rho$  be an arc properly embedded in  $\Sigma'$ , to the right of  $\gamma$  at least one endpoint. We construct an arc  $\sigma_\rho$ , properly embedded in  $\Sigma$ , as follows: Begin by orienting  $\rho$  away from its endpoint along  $\gamma$  (where, if  $\rho$  is to the right of  $\gamma$  at *each* endpoint, we orient such that  $\partial^- \rho >_\gamma \partial^+ \rho$ , where  $>_\gamma$  denotes the ordering given by orientation). Then extend  $\rho$  from  $\partial^- \rho$ , in a neighborhood  $U$  of  $\gamma$ , up to a point in  $\partial\Sigma$  to the left of  $\partial^- \gamma$ . Call the extended arc  $\rho'$ . Finally (Figure 15):

- (A) If  $\partial^+ \rho \in \partial\Sigma$ , set  $\sigma_\rho = \rho'$ .
- (B) If  $\rho$  is right of  $\gamma$  at each endpoint, extend  $\rho'$  from  $\partial^+ \rho'$ , in  $U$ , to a point of  $\partial\Sigma$  to the right of  $\partial^- \gamma$ .
- (C) If  $\rho$  is left of  $\gamma$  at  $\partial^+ \rho$ , and  $\partial^- \rho >_\gamma \partial^+ \rho$ , extend  $\rho'$  from  $\partial^+ \rho'$ , in  $U$ , to a point of  $\partial\Sigma$  to the left of  $\partial^- \rho'$ .

- (D) If  $\rho$  is left of  $\gamma$  at  $\partial^+\rho$ , and  $\partial^+\rho \geq_\gamma \partial^-\rho$ , extend  $\rho'$  from  $\partial^+\rho'$  in  $U$  to a neighborhood of  $x_0$ , then turn left, and continue parallel to  $\partial A$  up to  $\partial\Sigma$ .

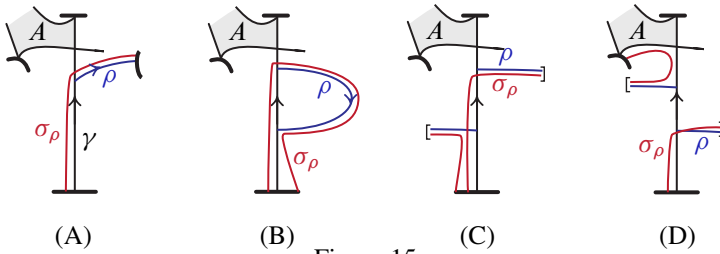

Figure 15

We will now describe 4 distinct possibilities for our pair  $\gamma, \varphi(\Gamma)$ , and for each exhibit an arc  $\rho$  such that the stabilization  $\tau_s$  corresponding to  $\sigma_\rho$  is reducing along  $\gamma$  (Figure 16).

- (1)  $\exists i < n$  such that  $R_i$  contains a path  $\rho$  of type (A). Then if  $\tau_s$  denotes the stabilization determined by  $\sigma_\rho$ , using Equation (1) we find that  $t = \#|s \cap \varphi(\Gamma)| = n - i$ . In particular,  $\tau_s$  has reduction  $2(n - i) - (n - i) > 0$ .
- (2)  $\exists i < j$  such that  $\rho_i = \rho_j$  is not parallel to  $\rho_0$ . Thus  $\rho_i$  is of type (B). Setting  $\rho = \rho_i$ , we have  $t = n - i + 1$ ,  $\#|s \cap \varphi(\Gamma)| = 2n - i - j + 1$ , and so  $\tau_s$  has reduction  $i + 1 - j > 1$ .
- (3)  $\exists i$  such that  $\rho_i$  terminates to the left of  $\gamma$ , at  $x_{j>i}$ . Thus  $\rho_i$  is of type (C). Setting  $\rho = \rho_i$ ,  $\tau_s$  has reduction  $j - i > 0$ .
- (4)  $\exists i$  such that  $\rho_i$  terminates to the left of  $\gamma$  at  $x_j$ , for  $j < i$ , and  $n - i \geq j - 1$ . Thus  $\rho_i$  is of type (D). Again setting  $\rho = \rho_i$ ,  $\tau_s$  has reduction  $(n - i + 1) - (j - 1) > 0$ .

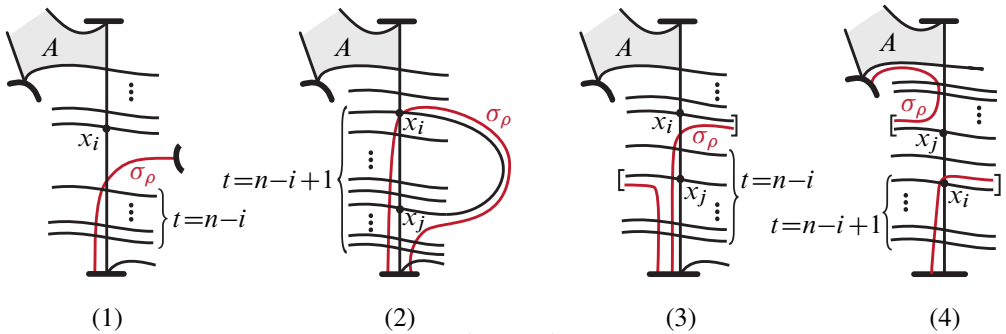

Figure 16

We now come to the proof of Lemma 4.2.

**Proof of Lemma 4.2** We will reproduce the full proof from [22] for the case that  $A$  is a bigon, and then indicate the modifications necessary for the more general case. Note then that, if  $A$  is a bigon, then in each of the above numbered cases, the defined stabilization curve  $s$  is such that no efficient representative of the isotopy class of  $s$  intersects  $A$ ; as such,  $A$  is again an incomplete region in the stabilized open book. Suppose then that none of the cases hold. Then:

- To avoid case (3), the arc  $\rho_0$  terminates to the right of  $\gamma$ .
- Let  $x_j$  be the other endpoint of  $\rho_0$ . Then  $j = n$ , else  $R_j$  satisfies case (1).

It follows then that  $\forall i < (n - 1)/2$ ,  $\rho_i = \rho_{n-i}$  is parallel to  $\rho_0$ : Supposing otherwise, let  $k = \min\{i \mid \rho_i \text{ is not parallel to } \rho_{i+1}\}$ . Then either  $R_k$  is as in case (1), or  $\rho_i$  is one of the 3 remaining cases, giving a contradiction.

We claim then that  $R_{(n-1)/2}$  has a unique boundary component (and thus has genus  $> 0$ ). Supposing otherwise, there is then some  $j$  such that  $R_{(n-1)/2}$  is to the left of  $e_j$ . But then a path in  $R_{(n-1)/2}$  from  $e_{(n-1)/2}$  to  $e_j$  gives a reduction of type (3) (if  $j > (n - 1)/2$ ) or (4) (if  $j < (n - 1)/2$ ).

So, to finish the argument, we need to demonstrate a stabilization whose associated reduction is zero, such that in the stabilized open book decomposition one can find a stabilization whose associated reduction is greater than zero. Let  $\alpha$  denote a homologically non-trivial simple closed curve in  $R_{(n-1)/2}$ , and  $\sigma$  the result of connect-summing a copy  $\gamma'$  of  $\gamma$ , perturbed at the endpoints such that  $\gamma \cap \gamma'$  is a single negative point, with  $\alpha$  (where the connect sum is done in the interior of  $R_{(n-1)/2}$ ) (Figure 17(a)). Then  $s$  has reduction 0, but in the stabilized open book,  $R_{(n-1)/2}$  has multiple boundary components, so is a reducible configuration.

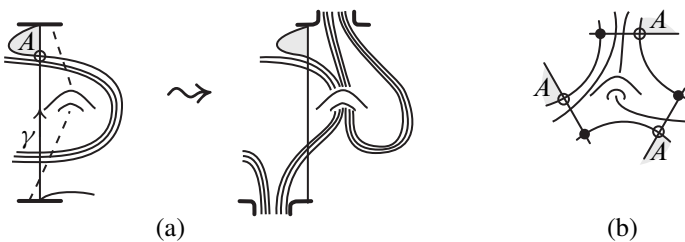

Figure 17

For the general case, the above argument shows that we may find a reducing stabilization; it is however no longer necessarily true that  $A$  is preserved by the stabilization, or, even if it is preserved, that it is preserved as an incomplete region. However, with a bit of case-checking, one can show that indeed, analogous to the bigon case, if

there is no reducing stabilization which preserves  $A$  as an incomplete region, then  $A$  has a “completion-with-genus” (Figure 17(b)), and that in this case we may always find a stabilization of, and then in the stabilized open book decomposition a further stabilization whose associated reduction is positive.  $\square$

**Observation 4.6** As an aside, we note that the bigon case of Lemma 4.2 tells us that, in the terminology of [12] and [16], we may always stabilize an “arc mapped to the left” into a “sobering arc”. As such, we may recover the full right-veering framework directly (ie without referring to the Giroux correspondence or consistency) from the construction of [12]. In fact, a careful look at the sobering arc produced by our construction reveals that the surface constructed by Goodman’s method in our case is actually an overtwisted disc, so one does not require the more general Bennequin inequalities.

## 5 Examples

In this final section, we illustrate the steps involved in using Theorem 1.3 with an example to check tightness of a contact manifold presented as a Legendrian surgery diagram. As hinted at in the proof of Theorem 1.4, there is a more-or-less standard process for transforming such diagrams into open book decompositions. The general procedure can be described as first using the methods of eg Ding and Geiges [3] to convert the surgery diagram into one in which each surgery coefficient is  $\pm 1$  relative to the contact framing, secondly using the framework of Giroux to build an open book decomposition of the standard  $(S^3, \xi_{st})$  in which each component of our link lies on a page, such that the page framing agrees with the contact framing (a careful proof of this fact was given by Plamenevskaya in [20]), and finally using the classical construction of Lickorish [19] to see that an open book decomposition for the resulting  $(M, \xi)$  is given by a composition of  $\varphi$  with positive/negative twists about the link components. Given such an open book decomposition, then, we may check for consistency.

For the specific example we have in mind, we start from the standard Legendrian unknot  $K$  (ie that whose front projection consists of two cusps and no crossings), which we push off of itself 4 times to obtain 5 copies  $K_i, i = 1, 2, \dots, 5$ . Then, for a given 6-tuple  $(a_1, a_2, a_3, b_1, b_2, b_3)$  of positive integers, let  $L_{(a_1, a_2, a_3, b_1, b_2, b_3)}$  denote the link obtained by adding  $a_i$  left cusps,  $b_i$  right cusps, to  $K_i$ . Finally, let  $\xi(a_1, a_2, a_3, b_1, b_2, b_3)$ , denote the contact 3-fold gotten by surgery on  $L$ , with coefficient  $tb(K_i) - 1$ , for  $i \leq 3$ , and  $tb(K_i) + 1$  otherwise (Figure 18(a)).

From this description, it is relatively straightforward to check that the open book decomposition illustrated in Figure 18(b) supports  $\xi(a_1, a_2, a_3, b_1, b_2, b_3)$  (here the

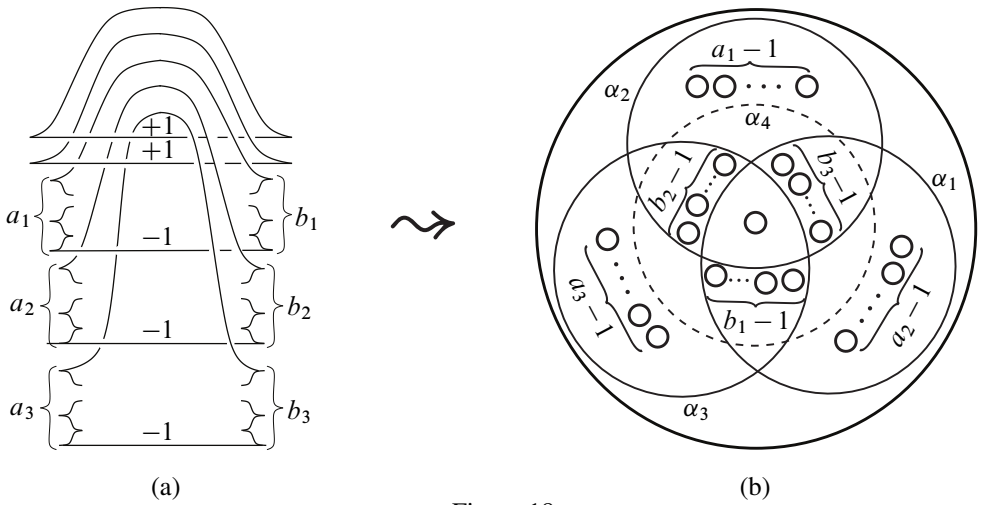

Figure 18

page is just the surface indicated, with genus 0 and  $a_1 + a_2 + a_3 + b_1 + b_2 + b_3 - 4$  boundary components, while the monodromy is  $\tau_{\alpha_4}^{-1} \tau_{\alpha_3} \tau_{\alpha_2} \tau_{\alpha_1} \tau_{\partial}$ , where  $\tau_{\partial}$  is the composition of a single positive twist around each bracketed boundary component).

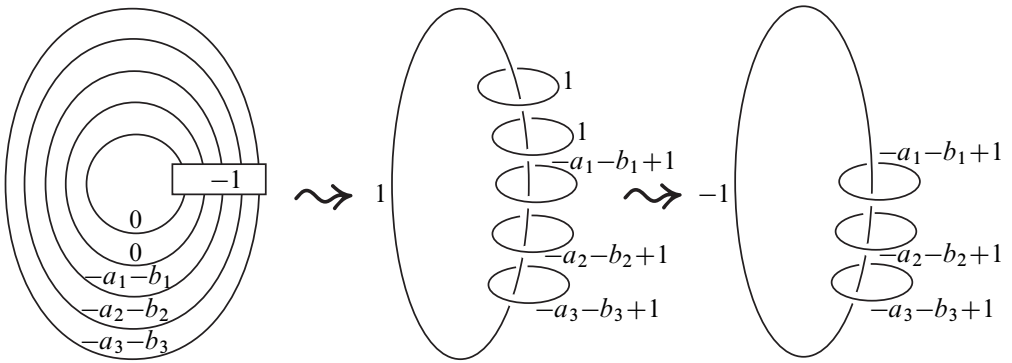

Figure 19

For the curious, we exhibit a topological surgery description of  $M$ , and simplifying Kirby moves thereof, in Figure 19. From this description one sees that  $M$  is a small Seifert manifold (ie the base surface is  $S^2$ , and there are exactly three singular fibers). Thus in (some candidate for) standard notation for such objects,

$$M = M\left(-1; \frac{1}{a_1 + b_1 - 1}, \frac{1}{a_2 + b_2 - 1}, \frac{1}{a_3 + b_3 - 1}\right).$$

For this paper, we will specialize to the case  $a_1 = a_2 = b_3 = 1$ , and  $a_3 > 2$ . It was shown in [10] (using some combination of convex surface theory with Heegaard–Floer homology) that  $\xi(1, 1, p, 2, 2, 1)$  is tight for all  $p$ . We will show how to recover this result with the methods of this paper, and further show that it is optimal, ie that all other possibilities are overtwisted.

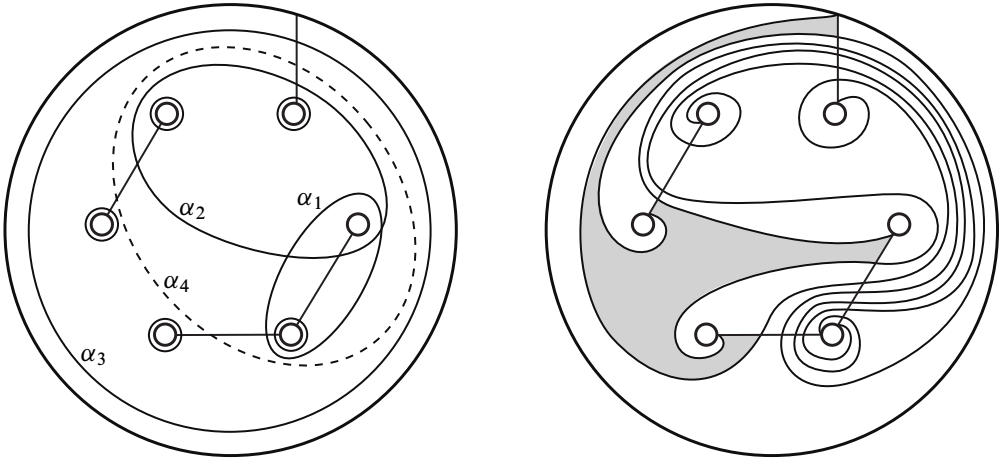

Figure 20:  $\begin{pmatrix} a_1 & b_1 \\ a_2 & b_2 \\ a_3 & b_3 \end{pmatrix} = \begin{pmatrix} 1 & 2 \\ 1 & 3 \\ 3 & 1 \end{pmatrix}$

We begin with the second claim. Consider firstly the case  $b_1 = 2, b_2 = a_3 = 3$ . The relevant open book decomposition is illustrated in Figure 20, along with an arc collection  $\Gamma$ . Note then that the region  $A \in \mathcal{R}_0^+(\Sigma, \varphi, \Gamma)$  indicated in the figure is incomplete, and thus the open book decomposition is inconsistent.

The more general situation, that  $b_1 \geq 2$ , and  $b_2, a_3 \geq 3$ , is indicated in Figure 21 (note that  $b_1$  and  $b_2$  are interchangeable); again, each monodromy is inconsistent, so each contact structure overtwisted.

It is left then to recover the above-mentioned result of [10], that  $\xi(1, 1, p, 2, 2, 1)$  is tight for all  $p$ . We start by defining  $\xi_p := \xi(1, 1, p, 2, 2, 1)$ , and supporting open book decomposition  $(\Sigma_p, \varphi_p)$ . Observe firstly that, if  $p \in \{1, 2\}$ , then  $\varphi_p$  has a positive factorization (for  $p = 1$ ,  $\alpha_3$  and  $\alpha_4$  are isotopic, while for  $p = 2$  this requires the so-called “lantern relation”), so the structure is tight by the results of Gromov, Eliashberg, and Giroux discussed in Section 1 (of course Theorem 1.4 gives an independent proof of this). As an aside, while the curves in our particular case happen to be homologically non-trivial, it is true in general that if a mapping class admits a factorization into positive twists, then, using the so-called “chain-relations” of the mapping class group,

it admits a factorization into positive twists about homologically non-trivial curves, so in particular can be obtained by Legendrian surgery on the standard (tight) structure on  $S^3$ .

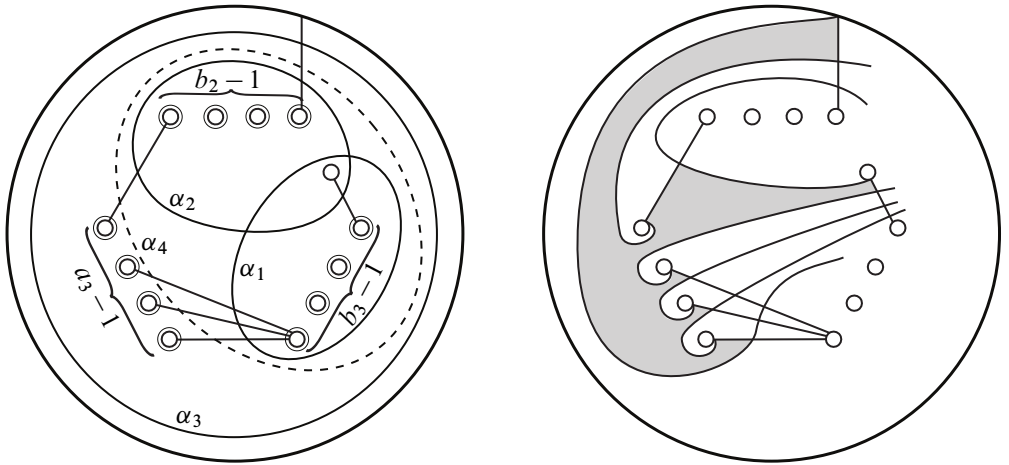

Figure 21

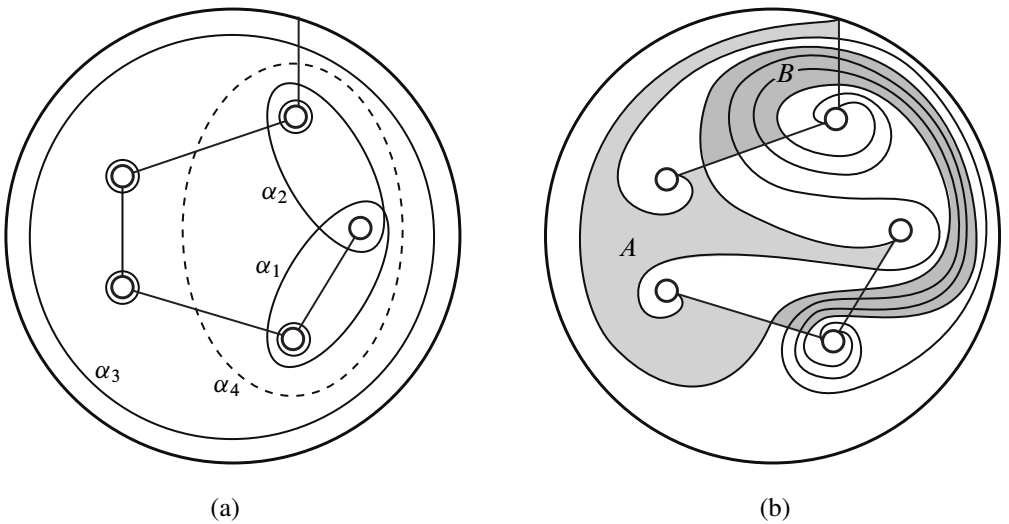

Figure 22: (a) The triple  $(\Sigma_3, \varphi_3, \Gamma_3)$ . (b) The collection  $\Gamma_3 \setminus \{\gamma\}$  supports a unique level-0 positive region  $A$ , which is completed by  $B$ , and such that  $\{A, B\}$  is a maximal tower.

For the case  $p = 3$ , let  $\Gamma_3$  denote the arc collection indicated in Figure 22(a). The configuration is sufficiently simple that one may simply check consistency “by hand”:



In general, it is not difficult to see that any level-0 positive region which has exactly one edge along each element of a basis is trivially completed, and not contained in any other tower. In particular, in the present situation is sufficient to consider those elements of  $\mathcal{R}_0^+(\Sigma_3, \varphi_3, \Gamma_3)$  which are supported by a proper subset of  $\Gamma_3$ . One may then check that, for each  $\gamma \in \Gamma_3$ ,  $\mathcal{R}_0^+(\Sigma_3, \varphi_3, \Gamma_3 \setminus \{\gamma\})$  has at most one element. It is then straightforward to verify that each of these is contained in a completed maximal tower. We illustrate this for a particular choice of  $\gamma$  in Figure 22(b).

For  $p > 3$ , let  $\Gamma_p$  denote the arc collection indicated in Figure 23(a). We leave as an exercise that the “collapse” indicated in Figure 23(b) induces an isomorphism on region collections (ie a 1–1 map which preserves incidences).

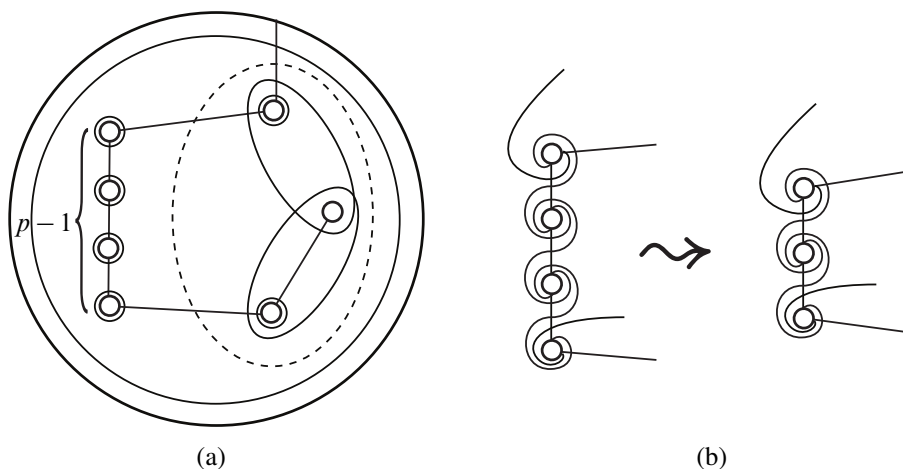

Figure 23

## References

- [1] **K L Baker, J B Etnyre, J Van Horn-Morris**, *Cabling, contact structures and mapping class monoids*, J. Differential Geom. 90 (2012) 1–80 [MR2891477](#)
- [2] **V Colin, K Honda**, *Reeb vector fields and open book decompositions*, J. Eur. Math. Soc. 15 (2013) 443–507 [MR3017043](#)
- [3] **F Ding, H Geiges**, *A Legendrian surgery presentation of contact 3–manifolds*, Math. Proc. Cambridge Philos. Soc. 136 (2004) 583–598 [MR2055048](#)
- [4] **S K Donaldson**, *Polynomial invariants for smooth four-manifolds*, Topology 29 (1990) 257–315 [MR1066174](#)
- [5] **Y Eliashberg**, *Classification of overtwisted contact structures on 3–manifolds*, Invent. Math. 98 (1989) 623–637 [MR1022310](#)

- [6] **Y Eliashberg**, *Filling by holomorphic discs and its applications*, from: “Geometry of low-dimensional manifolds, 2”, (S K Donaldson, C B Thomas, editors), London Math. Soc. Lecture Note Ser. 151, Cambridge Univ. Press (1990) 45–67 [MR1171908](#)
- [7] **Y Eliashberg**, *Topological characterization of Stein manifolds of dimension  $> 2$* , Internat. J. Math. 1 (1990) 29–46 [MR1044658](#)
- [8] **Y Eliashberg**, *Unique holomorphically fillable contact structure on the 3–torus*, Internat. Math. Res. Notices (1996) 77–82 [MR1383953](#)
- [9] **JB Etnyre**, *Lectures on open book decompositions and contact structures*, from: “Floer homology, gauge theory, and low-dimensional topology”, (D A Ellwood, P S Ozsváth, A I Stipsicz, Z Szabó, editors), Clay Math. Proc. 5, Amer. Math. Soc. (2006) 103–141 [MR2249250](#)
- [10] **P Ghiggini, P Lisca, A I Stipsicz**, *Tight contact structures on some small Seifert fibered 3–manifolds*, Amer. J. Math. 129 (2007) 1403–1447 [MR2354324](#)
- [11] **E Giroux**, *Géométrie de contact: de la dimension trois vers les dimensions supérieures*, from: “Proceedings of the International Congress of Mathematicians, Vol. II”, (T Li, editor), Higher Ed. Press, Beijing (2002) 405–414 [MR1957051](#)
- [12] **N Goodman**, *Overtwisted open books from sobering arcs*, Algebr. Geom. Topol. 5 (2005) 1173–1195 [MR2171807](#)
- [13] **M Gromov**, *Pseudoholomorphic curves in symplectic manifolds*, Invent. Math. 82 (1985) 307–347 [MR809718](#)
- [14] **K Honda**, *On the classification of tight contact structures, I*, Geom. Topol. 4 (2000) 309–368 [MR1786111](#)
- [15] **K Honda**, *Gluing tight contact structures*, Duke Math. J. 115 (2002) 435–478 [MR1940409](#)
- [16] **K Honda, W H Kazez, G Matić**, *Right-veering diffeomorphisms of compact surfaces with boundary*, Invent. Math. 169 (2007) 427–449 [MR2318562](#)
- [17] **K Honda, W H Kazez, G Matić**, *On the contact class in Heegaard Floer homology, J. Differential Geom.* 83 (2009) 289–311 [MR2577470](#)
- [18] **T Ito, K Kawamuro**, *Overtwisted discs in planar open books*, Internat. J. Math. 26 (2015) 1550027, 29 [MR3327490](#)
- [19] **W B R Lickorish**, *A representation of orientable combinatorial 3–manifolds*, Ann. of Math. 76 (1962) 531–540 [MR0151948](#)
- [20] **O Plamenevskaya**, *Contact structures with distinct Heegaard Floer invariants*, Math. Res. Lett. 11 (2004) 547–561 [MR2092907](#)
- [21] **CH Taubes**, *The Seiberg–Witten and Gromov invariants*, Math. Res. Lett. 2 (1995) 221–238 [MR1324704](#)
- [22] **A Wand**, *Tightness and open book decompositions* in preparation

- [23] **A Wand**, *Factorizations of diffeomorphisms of compact surfaces with boundary*, preprint (2014) [arXiv:0910.5691](https://arxiv.org/abs/0910.5691)
- [24] **A Wand**, *Tightness is preserved by Legendrian surgery*, preprint (2014) [arXiv:1404.1705](https://arxiv.org/abs/1404.1705)
- [25] **A Weinstein**, *Contact surgery and symplectic handlebodies*, *Hokkaido Math. J.* 20 (1991) 241–251 [MR1114405](https://doi.org/10.1007/BF01144405)

Laboratoire de Mathématiques Jean Leray, Université de Nantes  
F-44322 Nantes, France

[wand@math.berkeley.edu](mailto:wand@math.berkeley.edu)

Received: 24 June 2015

