

Journal of Mechanics of Materials and Structures

**MECHANICS OF FLYING BUTTRESSES:
THE CASE OF THE CATHEDRAL OF MALLORCA**

Paula Fuentes

Volume 13, No. 5

December 2018



MECHANICS OF FLYING BUTTRESSES: THE CASE OF THE CATHEDRAL OF MALLORCA

PAULA FUENTES

The function of the flying buttress is to take the thrust from a central vault and carry it over the lateral aisle to the external buttresses. Flying buttresses also resist lateral loads such as wind and seismic loads. When there is an additional upper tier, its main function is to carry these lateral loads. The structural behavior of flying buttresses has been studied by several authors since the 19th century with different approaches. An accurate survey of the cathedral of Mallorca has been used to study these elements. The flying buttresses in the cathedral of Mallorca, with ca. 9 m span and around 30 tons weight, are probably the biggest in Gothic architecture. Their position approximately 30 m above ground makes them very sensitive to the leaning of the buttresses. First, an overview of the structural behavior of flying buttresses will be provided, within the theoretical framework of limit analysis. Then, the general equilibrium, deformations and crack patterns of the flying buttresses in the cathedral of Mallorca will be analyzed. The local problems, such as the sliding of the head of the flyers, and the different solutions that have been adopted through history will be studied.

1. Structural behavior of flying buttresses

Several authors have studied flying buttresses from the point of view of their structural behavior by employing different approaches. Viollet-le-Duc in his *Dictionnaire* [1854] dedicates an article to this element, making some qualitative notes about its structural behavior.

The first complete static analysis was carried out by Mohrmann for the third edition of Ungewitter [1890], applying graphic analysis to the study of Gothic buildings, including flying buttresses (Figure 1). He differentiated between the function of lower and upper flyers, assigning the upper ones the function of taking the wind load. The contributions of Mohrmann were known in the United Kingdom through the work of Rosenberg [1936]. Fitchen [1955] further discussed the function of the upper flying buttresses.

The most complete study of the structural role of flying buttresses was made by Heyman [1966; 1967], who is also responsible for the application and development of limit analysis theory to masonry structures [Heyman 1995; 2008]. Applying limit analysis theory to a masonry arch, it is possible to say that if we find a thrust line contained inside the arch, the arch will not collapse. As the arch is not a statically determinate structure, it is not possible to know the “actual” thrust line. However, it is possible to establish the boundaries within which the thrust will be. The thrust line with the largest rise and the smallest span that fits inside the arch corresponds to the minimum thrust (Figure 2, left top), while the one with the smallest rise and largest span corresponds to the maximum thrust (Figure 2, left bottom). In these two cases, three hinges will form at the points where the thrust line touches the border of the arch, turning it into a statically determinate structure. Minimum thrust will occur when the abutments spread

Keywords: Flying buttresses, cathedral of Mallorca, limit analysis of masonry structures.

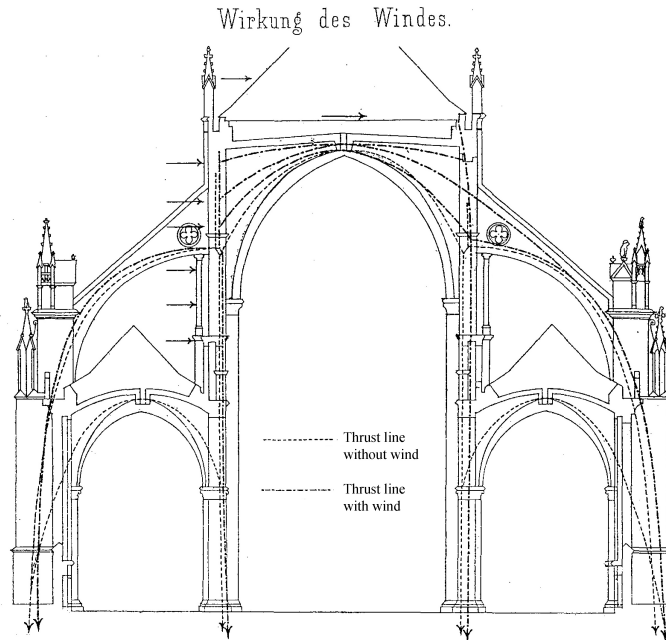

Figure 1. Cross section of the cathedral of Strasbourg showing the thrust line with and without wind [Ungewitter 1890]. Dotted line: thrust line without wind. Dotted-dashed line: thrust line with wind. Note that, with wind, the thrust line goes through the wall over the transverse arches.

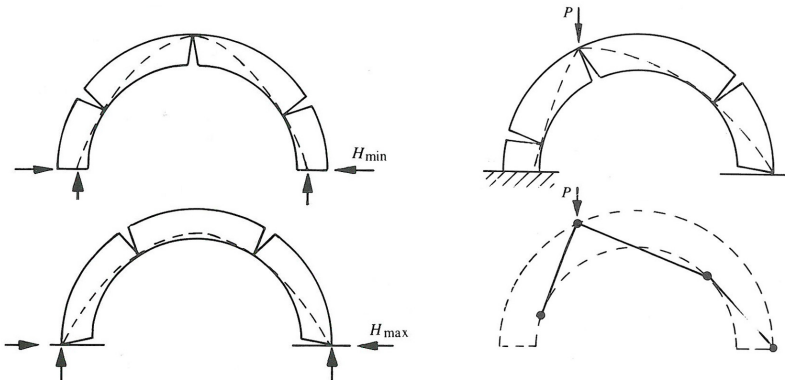

Figure 2. Semicircular arch: line of minimum thrust and line of maximum thrust (left column) and collapse mechanism (right column) [Heyman 1995].

and the arch has to accommodate to the new span with the formation of the three hinges shown in Figure 2 (left top). If a fourth hinge is formed, the structure will turn into a mechanism (Figure 2, right column).

In the case of flying buttresses, the line of minimum thrust is shown in Figure 3 (left) for the long flyer of Nôtre-Dame, Paris. The mechanism of three hinges formed by the spreading of the abutments is shown in Figure 3 (center).

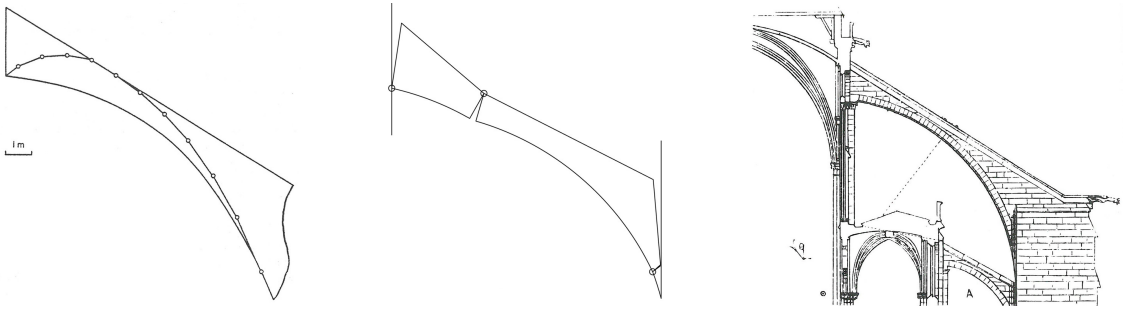

Figure 3. Left: passive line of thrust in the flying buttress of Nôtre-Dame, Paris [Heyman 1966]. Center: flying buttress of Nôtre-Dame with a spreading of the abutments. Right: partial cross-section of Nôtre-Dame [Viollet-le-Duc 1854].

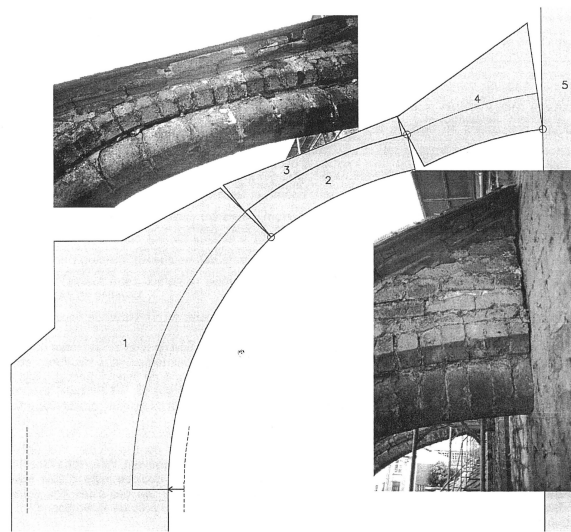

Figure 4. Cracking forming three hinges in a flying buttress at the Dominican church of Louvain [Smars 2000].

Flying buttresses are usually formed of three parts, that is, the arch on the bottom, a vertical wall above the arch, and a coping running along the top of this wall, where a gutter may be present to conduct rainwater (Figures 3 and 4). In some cases, because of the construction of the flyer, these parts may deform separately, as shown in Figure 4 [Smars 2000, pp. 167–169]. The wall between the arch and the coping is sometimes lightened by means of an openwork tracery, resulting in a lower and an upper ribs that can be considered to act independently from a structural behavior point of view. Fitchen noted that, in this case, the upper straight strut does not create inward pressure, stabilizing at the same time the lower arch because of its weight [Fitchen 1961, p. 78]. Ungewitter considered that the upper rib acts as a shore that can take any variable forces from zero to the crushing limit of the material [Ungewitter 1890, pp. 160–161].

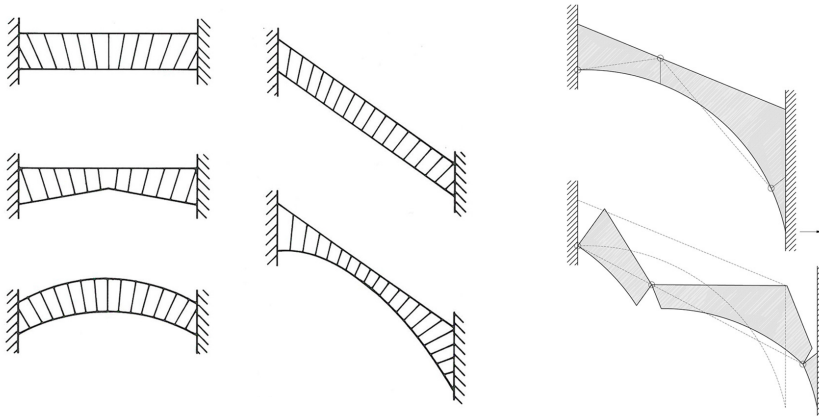

Figure 5. First and second column: arches that cannot collapse by the formation of a four hinge mechanism [Heyman 1995]. Third column: snap-through mechanism for a flying buttress.

As Heyman pointed out, for some arch geometries it is not possible to find a mechanism of collapse. This is the case of flat arches, and most flying buttresses, which are a development on the flat arch (Figure 5, first and second column) [Heyman 1995, p. 20]. Considering infinite compressive strength, these arches will only collapse if the abutments spread enough to form a *snap-through* mechanism that requires very large displacements (Figure 5, third column).

Limit analysis of masonry structures assumes that the sliding between two stones is impossible; however, there is a common problem in flying buttresses regarding the sliding at their head. Considering the line of minimum thrust and depending on the form of the flyer, the thrust may be very inclined in the upper part, and it may be outside the cone of friction (Figure 3, left). In this situation, the first voussoirs may slide along the wall of the main nave. The construction details of the flyer, which is not usually connected to the wall, permits this sliding. The absence of connection between the flying buttress and the wall has been discussed by Viollet-le-Duc [1854, p. 64] and Ungewitter [1890, p. 396]. Both stated that a connection with the wall could cause damages, as the flying arch would not be able to move freely.¹

Master masons were aware of the sliding problem and they took measures to avoid it. The common solution in French Gothic was placing a column or a pilaster under the head of the buttress (Figure 3, right). In the case of Mallorca, as will be seen, master masons used a solution unique in Gothic construction, placing stone bracings under the head to avoid this sliding. It is also possible to avoid the sliding by varying the form of the flyer, as remarked by Heyman [1966, p. 264] in the case of Lichfield cathedral (Figure 6), where the thinness and slope of the flyer causes an almost horizontal thrust at its head.

More recently Nikolinakou et al. [2005] have studied the structural behavior of early French flying buttresses, analyzing the significance of their forms and the possible failure modes. They demonstrated that shorter and less sloped flying buttresses have more tendency to sliding failure [Nikolinakou et al. 2005, pp. 1201–1203, Figure 6a].

¹An example of this sliding can be seen in [Nikolinakou et al. 2005, p. 1202, Figure 7]. The independent construction of the flyer and the wall is visible in the cathedral of Mallorca.

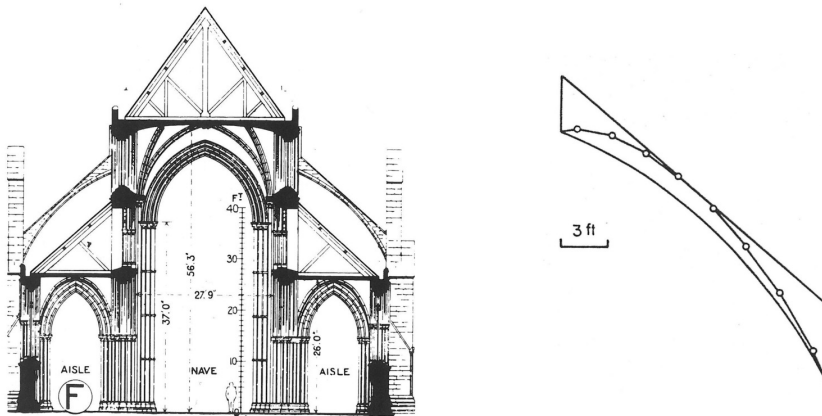

Figure 6. Left: Lichfield cathedral. Right: line of minimum thrust in the flying buttress at Lichfield cathedral; note the almost horizontal thrust at the head [Heyman 1966].

2. The flying buttresses in Mallorca

The construction of the cathedral of Mallorca was begun in the 14th century. The last bay was finished in the 17th century. In the 19th, the west façade was replaced by a neo-Gothic one. Despite the long construction, the original design was kept with only small variations.²

The cathedral has the highest central nave in Spanish Gothic architecture, reaching 44 m. The span, approximately 18 m, is one of the longest and the pillars are some of the most slender found in a Gothic building (Figure 7). The construction of a building with these dimensions was for sure a structural challenge for the master builders.³ Flying buttresses are a fundamental element in the equilibrium of the building and their study is an important topic, since they have a considerable size (around 9 m span), and it is possible to observe deformations, sliding and original solutions responding to these problems.

It is worth discussing the presence of transverse walls over the transverse arches of the nave, connecting the upper flying buttresses found on either side (Figures 7 and 8). As Ungewitter [1890, p. 388] mentioned, the upper flyers do not benefit from the thrust of the vault to counteract their own thrust, and the construction of a transverse wall over the transverse arch between the both sides of the building increases their stability.⁴ Besides some construction differences, the shape of the flying buttresses is mainly the same in all different bays. The survey of the cathedral of Mallorca provided the possibility of studying the actual deformation of the flying buttresses and relate it to the leaning of the buttresses.⁵

²A complete work about the cathedral has been done in Fuentes and Wunderwald [[≥ 2018](#)]. The variations on the design regarding the flying buttresses and other elements are explained here.

³The stability of the cathedral has been analyzed with different approaches throughout history. A summary of these studies can be found in Fuentes and Wunderwald [[2017](#)].

⁴Besides a possible function to counteract the thrust of the flyers, these walls have a fundamental role in the general stability of the building [Rubió i Bellver 1912, p. 100] and [Huerta Fernández 2017, p. 15].

⁵The survey of the cathedral has been done with the collaboration of the “Raumbezogene Informationssysteme” of the BTU Cottbus-Senftenberg.



Figure 7. Cross-section of the cathedral of Mallorca: through the center of the fifth bay (left) and through the fifth pillars (right) [Fuentes and Guerra 2015].

Based on the survey, the original shape of the flyers has been supposed as shown in Figure 9. This ideal geometry is based on the fourth flying buttress of the north side, where the presence of the tower has prevented large deformations. A radius of 8.8 m fits very well with the survey.

2.1. Static behavior of the flying buttresses in Mallorca. In his structural analysis of the cathedral of Mallorca, Rubió [Rubió i Bellver 1912, pp. 120–121] concluded that the cathedral may have been better without the upper tier of flying buttresses, since these are very large and consequently exert a large thrust.

More recently, Huerta [2017, p. 45] performed a structural analysis of the cathedral of Mallorca and he confirmed that the flying buttresses are well designed and that their deformations are typical in this type of element.

For the present analysis of the flying buttresses, a specific weight of 18 kN/m^3 has been assumed.⁶ The lower flyer has been calculated to have a weight of 408 kN. The passive thrust is 80 kN. The upper flying buttress has a smaller passive thrust of 75 kN and a weight of 330 kN (Figure 10).

The matter of the minimum thrust has been considered, but there is also an upper limit of the thrust that is given by the least inclined line that can fit in the flyer. However, as explained above, thanks to their shape, a straight line can be fitted inside the flyer without touching the edges and it is therefore possible to say that the maximum thrust is infinite, being only limited by the crushing strength of the material. That is, considering a crushing strength of 20 N/mm^2 , a maximum thrust of 29,000 kN would be required for the lower flyers to fail,⁷ while the upper flying buttresses would fail by crushing with a thrust of 18,800 kN. As can be seen, the flying buttresses are far away from their crushing failure.

⁶In the report made by the Universitat Politècnica de Catalunya, various tests were carried out on the stones of the flying buttresses, obtaining different specific weights. An average value has been deduced from these tests [UPC 2006–2008, Documento 3, §1.4].

⁷Some tests have been performed on the stones of the flying buttresses. The results vary considerably, yielding a minimum strength of 42 N/mm^2 and a maximum of 152 N/mm^2 [UPC 2006–2008, Documento 3, §1.4].

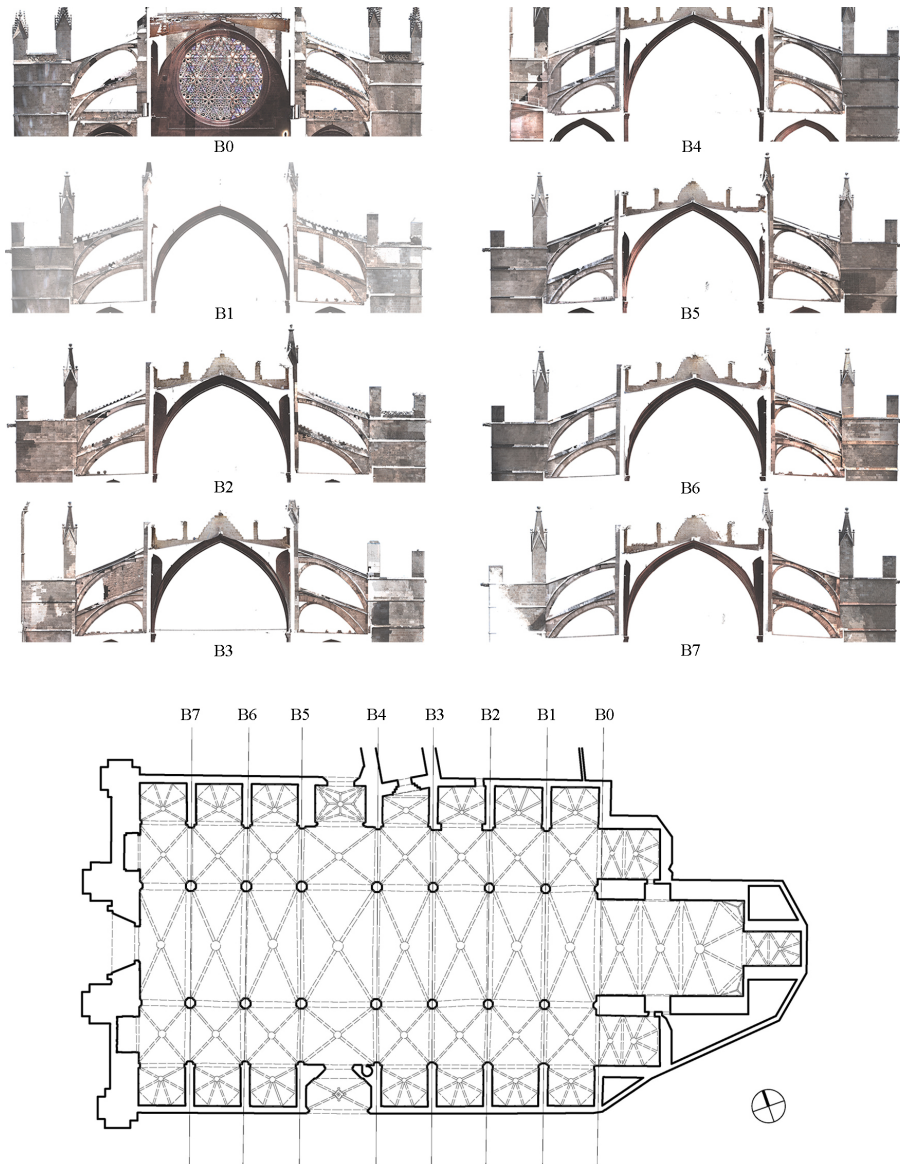

Figure 8. Elevations of all the flying buttresses (with the exception of the ones on the façade) and plan view of the cathedral of Mallorca (based on the cloud of points by Rex Haberland).

2.2. Cracks and distortions. As explained earlier, the line of minimum thrust is the one that occurs when there is spreading of the supports. The existing leaning of the buttresses, published by Fuentes and Guerra [2016], has been used in this study. As shown in Table 1, the leaning is greater in the south side (towards the sea). These movements appear to be quite large. However, they are around 1% of the height of the buttress, which is not a big movement (see Figure 7, where the distortions have been drawn, but are barely noticeable).

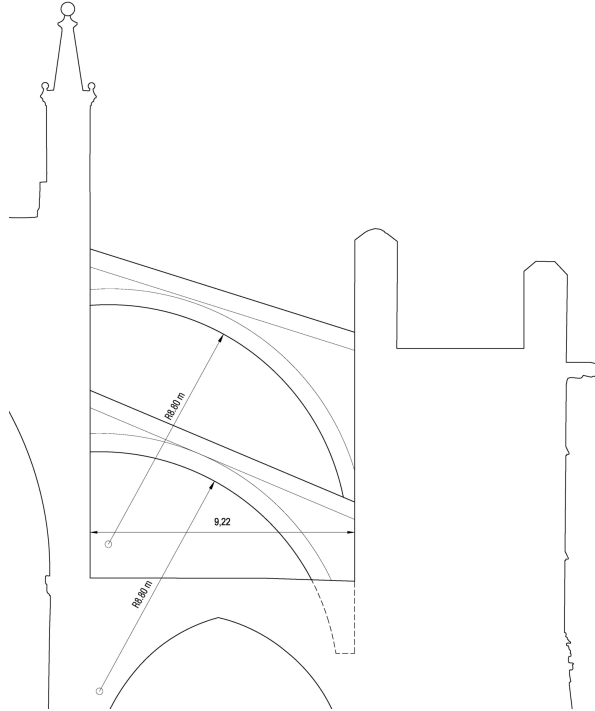

Figure 9. Ideal geometry considered for the structural analysis.

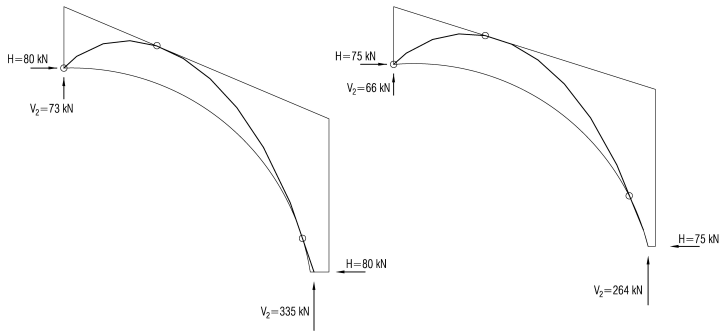

Figure 10. Line of minimum thrust: lower flying buttress (left) and upper flying buttress (right).

The leaning of the buttresses causes a drop in the central part of the flyers, which can be seen most clearly in the upper flyers. There is an additional movement to be considered. The wall of the central nave leans inwards towards the upper part, at the height of the upper flyer, resulting in an additional increase of the span of this flyer.⁸ Figure 11 shows the deformation of the ideal flying buttresses, considering the leaning of the second southern buttress B1 (from Table 1: 26.5 cm in the upper flyers and 20.5 cm in

⁸This leaning inwards of the upper part of the lateral wall of the main nave can be caused because the crack opened due to the increasing of the span of the main vault (wall's crack), can be closed again when the upper flying buttress thrust inwards.

portico	out of plumb (m)							
	B0		B1		B2		B3	
height (m)	N	S	N	S	N	S	N	S
34.7	0.395	0.270	0.470	0.265	0.130	0.330	tower	0.360
27.3	0.310	0.215	0.395	0.205	0.115	0.305	tower	0.305
	B4		B5		B6		B7	
	N	S	N	S	N	S	N	S
34.7	tower	0.445	0.145	0.400	0.105	0.340	0.205	0.280
27.3	tower	0.350	0.085	0.310	0.080	0.245	0.150	0.230

Table 1. Out of plumb of the external buttresses of the different porticos, on the north and south elevations (see plan in Figure 8). The buttresses lean always outwards from the nave, leading to an increased span for the flying buttresses. The table gives the out of plumb at two heights: 27.3 m and 34.7 m above the floor (table made after [Fuentes and Guerra 2016]).

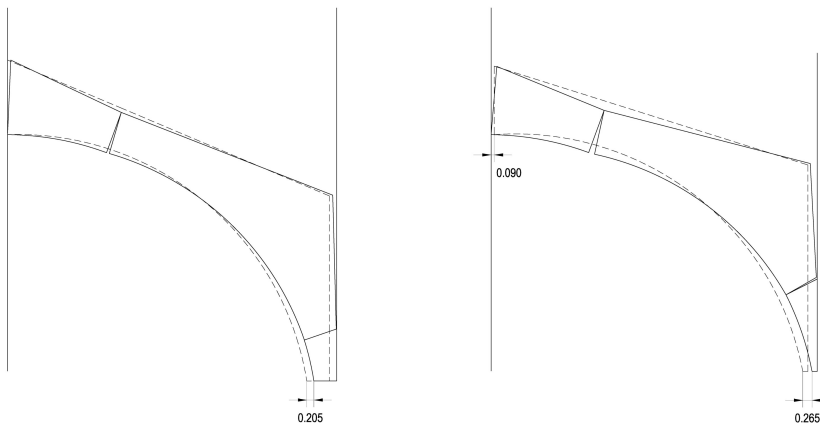

Figure 11. Theoretical deformation of the ideal flying buttress for the leaning of the south buttress B1 and the leaning of the nave wall. Geometry previous the deformation in dashed line: lower flying buttress (left) and upper flying buttress (right).

the lower flyers) and the inwards leaning of the nave wall (9 cm). For these deformations, the maximum drop is 18 cm in the lower flyer and 27 cm in the upper flyer (Figure 11).

Comparing the theoretical deformation with the survey, the maximum deviation measured in the lower flying buttress is 6 cm in the lower part and around 8 cm in the upper flyer, at the point of the upper crack. Despite these differences, the general form of the theoretical deformation agrees with the survey (Figure 12). Despite the deformations being visible, cracks have probably been filled in restoration works along the centuries and are not evident.

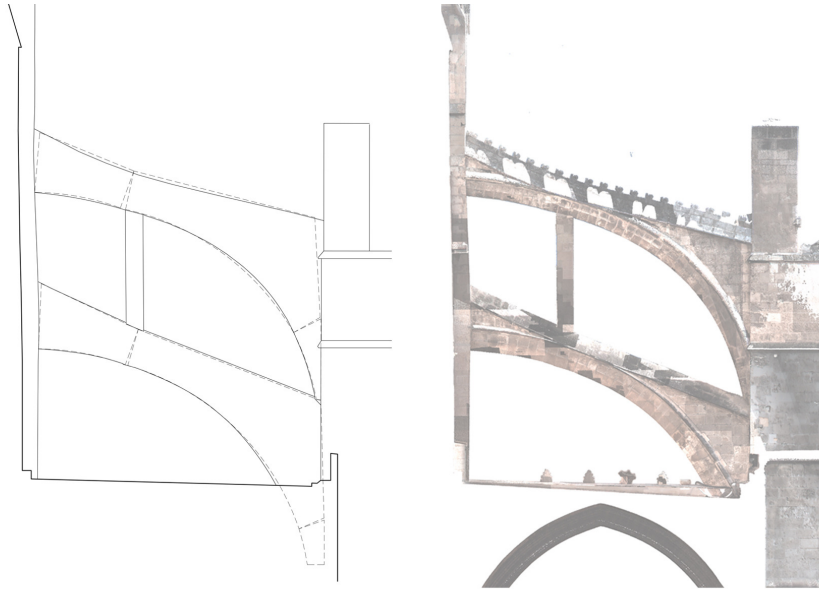

Figure 12. Comparison of the theoretical deformation (dashed line) with the real deformation (continuous line) (left) and orthophoto of the south flying buttresses B1 (right) (based on the point cloud by Rex Haberland).

The spreading that would cause the collapse of the flying buttresses shown in [Figure 5](#) (right column), would be 1.38 m in the upper flyer and 1.81 m in the lower flyer. These movements are far from the actual movement of the flyers, which show a maximum opening of 44.5 cm in the south flying buttress B4 ([Table 1](#)).

The noticeable deformations have been a concern for the architects of the cathedral along history. The introduction of stone struts and even a wall between lower and upper flying buttresses is a proof of the fear of some of these master builders.⁹ Nonetheless, the flying buttresses are well designed as demonstrated by the fact that an equilibrium solution has been found and the deformations coincide with the expected. Therefore, there is no need for struts or walls between the two tiers of flying buttresses.

Pillars between the two flying buttresses are currently present in 4 of the 16 pairs. However, looking at historical photographs it is possible to verify that at least three more pillars were found in the first two pairs of flyers, close to the apse, with two under the lower flying buttress and another one between the lower and the upper flying buttresses ([Figure 13](#)). At some point, these pillars were removed, probably because they were the only three visible from the ground.¹⁰

2.3. Prevention of sliding. As discussed in [Section 1](#), the flying buttresses of Mallorca are not connected to the nave wall. Therefore, sliding may occur for the line of minimum thrust. Note that the thrust against the wall in the lower flyers forms an angle of 42.4° , while in the upper flyers it is of 41.4° ([Figure 10](#)).

⁹In 1677 and 1739 experts recommended building stone “feet” (*peus de pedra*, in the original mallorquin) in the flying buttresses. These stone “feet” were probably these pillars [[Domenge and Conejo 2003](#), p. 12]. About those concerns and historical expertise on the stability of the flying buttresses, see [[Domenge 2017](#)].

¹⁰As Rubió’s work is dated in 1912, presumably these pillars were removed after this date.

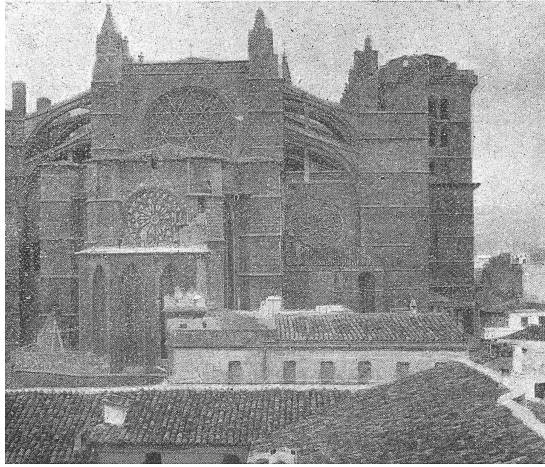

Figure 13. Exterior view of the cathedral of Mallorca from the east. Note the two pillars in the north flying buttresses and another one under the lower south flying buttress [Rubió i Bellver 1912].

For a common conservative friction coefficient of 0.75^{11} and for the minimum thrust, the first stone would slide down the wall in both cases. In Mallorca it is possible to observe some sliding, but only in a number of the upper flyers. In [Figure 14](#) it is possible to notice the sliding of the second voussoir. It is important to remark that some interventions have been carried out to place the upper part of the flyer in its original position and to disguise the movement that would be very evident in the moldings. The fact that there is no sliding in the lower flying buttresses is probably because the actual thrust is larger than the minimum. This is expected, as it has to counteract the thrust of the main vault. This horizontal thrust of the main vault has been calculated by Huerta [2017, p. 28], obtaining a value of 340 kN.

As in the upper flying buttresses there is no thrust to counteract, their state is that of minimum thrust or close to it, and since they are in the limit of possible sliding, some of them present this problem while others do not. This difference most likely depends on small variations of the thrust or on the contact surface, as small irregularities on the surface can increase the friction coefficient.

Probably aware of the sliding problem, experts in the 17th and 18th centuries recommended the construction of bracing in the flyers [Domenge and Conejo 2003, p. 12]. It is a completely original solution that has not been found in other Gothic buildings ([Figure 8](#) and [Figure 16](#)). The bracing solved the problem, but resulted in unexpected distortions. The effect is shown in [Figure 15](#). When the span increases, three hinges appear in the flyer, one on the intrados at the springing, another one on the extrados close to the midpoint, and the third one in the bracing. When the bracing rotates, the space for the voussoirs between the bracing and the wall increases. As a result, the voussoirs slide and descend. However, further movements are constrained by the bracing itself. This causes a particular shape with double curvature in the upper part of the flying buttress, visible in some of them ([Figure 16](#)).

The master mason probably noticed this effect and tried to correct it with a small stone strut between the flying buttress and the bracing, as can be seen in [Figure 17](#).

¹¹The friction angle in stone is usually between 30° and 40° .



Figure 14. Sliding in the upper flying buttress B6N. Note that the sliding is not between the wall and the first voussoir, but between first and second voussoirs [Photo: Roland Wiczorek, BTU Cottbus-Senftenberg].

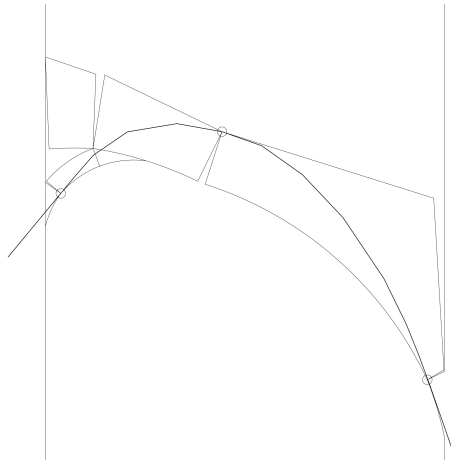

Figure 15. Line of minimum thrust for the flying buttress with the insertion of bracing.



Figure 16. Orthophoto of south flying buttresses B1 (based on the cloud of points by Rex Haberland).

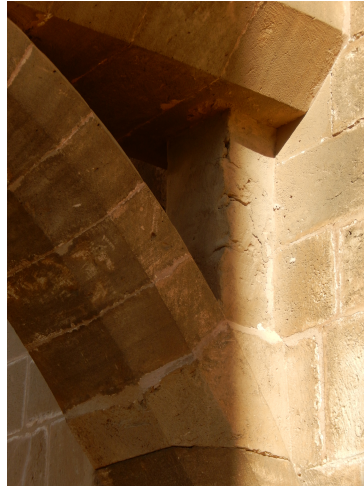

Figure 17. Small stud between the lower flying buttress and the support in B6S (photo: Huerta 2016).

3. Conclusions

The theoretical framework of limit analysis has been used to explain the behavior of flying buttresses. This theory can explain the characteristic movements of these elements, such as the distortions and some cases of sliding. A particular study of these effects has been carried out for the flying buttresses of the cathedral of Mallorca, which are some of the largest in Gothic architecture. These flying buttresses have a fundamental role in the stability of the cathedral. They are stable and admit an infinite range of lines of thrust in equilibrium with the loads, permitting the thrust to adapt to different combination of loads that may be experienced throughout the building's life. The visible distortions, that have been the origin of various interventions along history, are the normal movements expected in response to the leaning of the external buttresses, and this leaning is far from the one that would cause the collapse of the flyers. The struts and walls between the lower and upper flying buttresses are, therefore, not necessary and demonstrate the fear caused by the perceptible distortions. Some sliding problems can be observed, as well as the original solution of introducing stone bracings to prevent them. The use of these bracings led to a further problem of deformations and subsequent introduction of an additional element, that is, the studs between the head of the flying buttresses and the bracing.

Acknowledgements

I would like to thank Santiago Huerta for the very helpful comments and suggestions on this paper and the Cabildo of the Cathedral of Mallorca for facilitating the work in the building. This paper has been written within the post-doc research project: "The Art of Vaulting. Design and Construction of Large Vaults in the Mediterranean Gothic", in the DFG-Graduiertenkolleg 1913 "Cultural and Technological Significance of Historic Buildings" at the BTU Cottbus-Senftenberg. The project is conducted by Dr. phil. Anke Wunderwald and the author.

References

- [Domenge 2017] J. Domenge Mesquida, “La catedral de Mallorca: visures pro rimedio fabrice (1581–1668)”, in *Visurar l’arquitectura gòtica: inspeccions, consells i reunions de mestres d’obra (s. XIV–XVIII)*, edited by J. Domenge Mesquida and J. Vidal Franquet, Edizioni Caracol, Palermo, 2017.
- [Domenge and Conejo 2003] J. Domenge and A. Conejo, “Establecimiento y datación de las diferentes reparaciones y reformas constructivas de la catedral a lo largo de su historia (1575–1775)”, art. 3 in *Estudio, diagnóstico, peritación y en su caso planteamiento de actuaciones sobre el comportamiento constructivo estructural de la catedral de Santa María, en la ciudad de Palma, Isla de Mallorca (Balears)*, Polytechnic Univ. Catalunya, Barcelona, 2003.
- [Fitchen 1955] J. Fitchen, “A comment on the function of the upper flying buttress in French Gothic architecture”, *Gaz. Beaux-Arts* (6) **45** (1955), 69–90.
- [Fitchen 1961] J. Fitchen, *The construction of Gothic cathedrals: a study of Medieval vault erection*, Univ. Chicago Press, 1961.
- [Fuentes and Guerra 2015] P. Fuentes and R. Guerra, “[Levantamiento para el análisis de estabilidad de la catedral de Mallorca](https://tinyurl.com/fuentguer)”, technical report, Cabildo Catedral de Mallorca, 2015, <https://tinyurl.com/fuentguer>.
- [Fuentes and Guerra 2016] P. Fuentes and R. Guerra, “Ampliación del levantamiento para el análisis de estabilidad de la catedral de Mallorca”, technical report, Cabildo Catedral de Mallorca, 2016.
- [Fuentes and Wunderwald 2017] P. Fuentes and A. Wunderwald, “[La construcción de las bóvedas de la catedral de Mallorca: una revisión bibliográfica](#)”, pp. 611–623 in *Actas del Décimo Congreso Nacional y Segundo Congreso Internacional Hispanoamericano de Historia de la Construcción, II* (San Sebastián, 2017), edited by S. Huerta et al., Inst. Juan de Herrera, Madrid, 2017.
- [Fuentes and Wunderwald \geq 2018] P. Fuentes and A. Wunderwald, “The vaults of Mallorca Cathedral: rising to a technical challenge”, to appear in *The art of vaulting: design and construction of large vaults in the Mediterranean Gothic*, Kulturelle und technische Werte historischer Bauten **2**.
- [Heyman 1966] J. Heyman, “The stone skeleton”, *Int. J. Solids Struct.* **2**:2 (1966), 249–279.
- [Heyman 1967] J. Heyman, “Beauvais Cathedral”, *Trans. Newcomen Soc.* **40**:1 (1967), 15–35.
- [Heyman 1995] J. Heyman, *The stone skeleton: structural engineering of masonry architecture*, Cambridge Univ. Press, 1995.
- [Heyman 2008] J. Heyman, *Basic structural theory*, Cambridge Univ. Press, 2008.
- [Huerta Fernández 2017] S. Huerta Fernández, “[Informe sobre la estabilidad de las bóvedas de la nave y el sistema de contrarresto de la catedral de Palma de Mallorca](http://oa.upm.es/45328)”, technical report, Cabildo Catedral de Mallorca, 2017, <http://oa.upm.es/45328>.
- [Nikolinakou et al. 2005] M. A. Nikolinakou, A. J. Tallon, and J. A. Ochsendorf, “Structure and form of early Gothic flying buttresses”, *Eur. J. Environ. Civ. Eng.* **9**:9-10 (2005), 1191–1217.
- [Rosenberg 1936] G. Rosenberg, “The functional aspect of the Gothic style”, *J. R. Inst. Br. Archit.* **43**:6 (1936), 273–290, 364–371.
- [Rubió i Bellver 1912] J. Rubió i Bellver, “Conferencia acerca de los conceptos orgánicos, mecánicos y constructivos de la Catedral de Mallorca”, *Anuario Asoc. Arquitectos Cataluña* **1912** (1912), 87–140.
- [Smars 2000] P. Smars, *Etudes sur la stabilité des arcs et voûtes: confrontation des méthodes de l’analyse limite aux voûtes gothiques en Brabant*, Ph.D. thesis, Katholieke Universiteit Leuven, 2000, <https://tinyurl.com/smarsphd>.
- [Ungewitter 1890] G. Ungewitter, *Lehrbuch der Gotischen Konstruktionen*, 3rd ed., Weigel, Leipzig, 1890.
- [UPC 2006–2008] “Estudio, diagnóstico, peritación y en su caso planteamiento de actuaciones sobre el comportamiento constructivo estructural de la catedral de Santa María, en la ciudad de Palma, Isla de Mallorca (Balears). Fase Segunda”, Polytechnic Univ. Catalunya, Barcelona, 2006–2008.
- [Viollet-le-Duc 1854] E.-E. Viollet-le-Duc, *Dictionnaire raisonné de l’architecture française du XIe au XVIe siècle, I*, Chapter “Arc-boutant”, pp. 60–83, A. Morel, Paris, 1854, <https://tinyurl.com/arcboutantJomms>.

Received 28 Apr 2018. Accepted 30 May 2018.

PAULA FUENTES: paula.fuentes@gmail.com
 Brandenburgische Technische Universität Cottbus-Senftenberg, Germany

JOURNAL OF MECHANICS OF MATERIALS AND STRUCTURES

msp.org/jomms

Founded by Charles R. Steele and Marie-Louise Steele

EDITORIAL BOARD

ADAIR R. AGUIAR	University of São Paulo at São Carlos, Brazil
KATIA BERTOLDI	Harvard University, USA
DAVIDE BIGONI	University of Trento, Italy
MAENGHYO CHO	Seoul National University, Korea
HUILING DUAN	Beijing University
YIBIN FU	Keele University, UK
IWONA JASIUK	University of Illinois at Urbana-Champaign, USA
DENNIS KOCHMANN	ETH Zurich
MITSUTOSHI KURODA	Yamagata University, Japan
CHEE W. LIM	City University of Hong Kong
ZISHUN LIU	Xi'an Jiaotong University, China
THOMAS J. PENCE	Michigan State University, USA
GIANNI ROYER-CARFAGNI	Università degli studi di Parma, Italy
DAVID STEIGMANN	University of California at Berkeley, USA
PAUL STEINMANN	Friedrich-Alexander-Universität Erlangen-Nürnberg, Germany
KENJIRO TERADA	Tohoku University, Japan

ADVISORY BOARD

J. P. CARTER	University of Sydney, Australia
D. H. HODGES	Georgia Institute of Technology, USA
J. HUTCHINSON	Harvard University, USA
D. PAMPLONA	Universidade Católica do Rio de Janeiro, Brazil
M. B. RUBIN	Technion, Haifa, Israel

PRODUCTION production@msp.org

SILVIO LEVY Scientific Editor

Cover photo: Wikimedia Commons

See msp.org/jomms for submission guidelines.

JoMMS (ISSN 1559-3959) at Mathematical Sciences Publishers, 798 Evans Hall #6840, c/o University of California, Berkeley, CA 94720-3840, is published in 10 issues a year. The subscription price for 2018 is US \$615/year for the electronic version, and \$775/year (+\$60, if shipping outside the US) for print and electronic. Subscriptions, requests for back issues, and changes of address should be sent to MSP.

JoMMS peer-review and production is managed by EditFLOW[®] from Mathematical Sciences Publishers.

PUBLISHED BY

 **mathematical sciences publishers**
nonprofit scientific publishing

<http://msp.org/>

© 2018 Mathematical Sciences Publishers

**Special issue on
Structural Analysis
of Real Historic Buildings (part 1)**

Preface	MAURIZIO ANGELILLO and SANTIAGO HUERTA FERNÁNDEZ	607
The structural engineer's view of ancient buildings	JACQUES HEYMAN	609
Mechanics of flying buttresses: the case of the cathedral of Mallorca	PAULA FUENTES	617
Analysis of 3D no-tension masonry-like walls	DEBORAH BRICCOLA, MATTEO BRUGGI and ALBERTO TALIERCIO	631
Cracking of masonry arches with great deformations: a new equilibrium approach	JOSÉ IGNACIO HERNANDO GARCÍA, FERNANDO MAGDALENA LAYOS and ANTONIO AZNAR LÓPEZ	647
Resistance of flat vaults taking their stereotomy into account	MATHIAS FANTIN, THIERRY CIBLAC and MAURIZIO BROCATO	657
Seismic vulnerability of domes: a case study	CONCETTA CUSANO, CLAUDIA CENNAMO and MAURIZIO ANGELILLO	679
Orthotropic plane bodies with bounded tensile and compressive strength	MASSIMILIANO LUCCHESI, BARBARA PINTUCCHI and NICOLA ZANI	691
A no-tension analysis for a brick masonry vault with lunette	MICHELA MONACO, IMMACOLATA BERGAMASCO and MICHELE BETTI	703