

*Pacific
Journal of
Mathematics*

**BEHAVIOR OF SOME CMC CAPILLARY SURFACES
AT CONVEX CORNERS**

JULIE CRENSHAW AND KIRK LANCASTER

BEHAVIOR OF SOME CMC CAPILLARY SURFACES AT CONVEX CORNERS

JULIE CRENSHAW AND KIRK LANCASTER

We construct examples of nonparametric surfaces $z = h(x, y)$ of zero mean curvature which satisfy contact angle boundary conditions in a cylinder in \mathbb{R}^3 over a convex domain Ω with corners. When the contact angles for two adjacent walls of the cylinder differ by more than $\pi - 2\alpha$, where 2α is the opening angle between the walls, the (bounded) solution h is shown to be discontinuous at the corresponding corner. This is exactly the behavior predicted by the Concus–Finn conjecture. These examples currently constitute the largest collection of capillary surfaces for which the validity of the Concus–Finn conjecture is known and, in particular, provide examples for all contact angle data satisfying the condition above for opening angles $2\alpha \in (\pi/2, \pi)$.

1. Introduction

Let Ω be an open set in the plane whose boundary is smooth except at a number of corner points. Assume that near each such corner point $P \in \partial\Omega$, the boundary consists of two curves, ω^+ and ω^- , meeting at P at an angle $2\alpha \in (0, \pi)$; this condition characterizes a *convex corner*. Let $\gamma : \partial\Omega \rightarrow [0, \pi]$ be continuous on each smooth piece of $\partial\Omega$, and assume that at each corner the limits

$$\lim_{\substack{Q \in \omega^+ \\ Q \rightarrow P}} \gamma(Q) =: \gamma_1 \quad \text{and} \quad \lim_{\substack{Q \in \omega^- \\ Q \rightarrow P}} \gamma(Q) =: \gamma_2$$

both exist. Also let $\Lambda = \Omega \times \mathbb{R}$ be the cylinder over Ω . We ask about the existence of a *capillary graph* over Ω with contact angle data γ ; that is, does there exist a surface $z = h(x, y)$ defined over $\overline{\Omega} \setminus \{\text{corners}\}$, satisfying the physical conditions that characterize a liquid interface for prescribed values of gravity and density, and meeting the walls of Λ at the prescribed angle γ ? (See [Equation \(2\)](#) for a formal statement.)

This question has received considerable interest. The *local* question of the existence and boundedness of a capillary graph near a corner P has been solved by

MSC2000: [primary 76D45](#); [secondary 35J67, 53A10](#).

Keywords: capillary graph, minimal surface, Concus–Finn conjecture, Riemann–Hilbert problem.

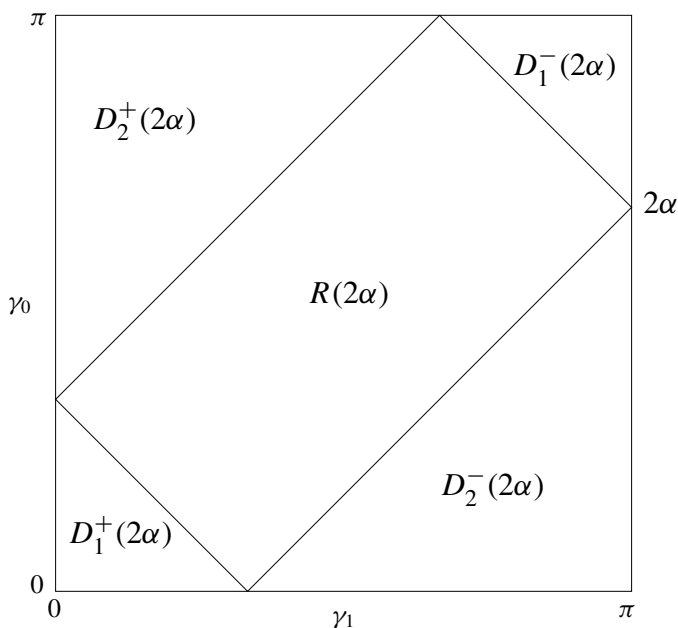

Figure 1. The Concus–Finn rectangle

Paul Concus and Robert Finn in all but one case. The current state of knowledge [Concus and Finn 1991; 1994; 1996; Finn 1986; 1996; Simon 1980; Tam 1986] is summarized by referring to Figure 1, in which the horizontal variable is γ_1 , the vertical variable is γ_2 and the corner opening angle is 2α :

- (i) A solution $z = h(x, y)$ will be continuous at P if $(\gamma_1, \gamma_2) \in R(2\alpha)$.
- (ii) There is no solution if $\kappa = 0$ and $(\gamma_1, \gamma_2) \in D_1^\pm(2\alpha)$.
- (iii) There is no solution which is bounded at P if $(\gamma_1, \gamma_2) \in D_1^\pm(2\alpha)$.
- (iv) There can exist a bounded solution $z = h(x, y)$ if $(\gamma_1, \gamma_2) \in D_2^\pm(2\alpha)$.

In case (iv), the continuity of the solution at P is unknown, but we have:

Conjecture [Concus and Finn 1996; Finn 1996]. *A local capillary graph at a corner P with data from a $D_2(2\alpha)$ domain has a jump discontinuity at P , whether in zero gravity or not.*

Fix $\delta \in (0, \pi/4)$ and consider the diamond-shaped region $\Omega \subset \mathbb{R}^2$ symmetric with respect to the coordinate axes and having vertices $(0, \pm 1)$ and $(\pm \tan \delta, 0)$. Label the vertices as in Figure 2, so the convex angle OAB has measure δ and the convex angle ABC has measure $2\alpha = \pi - 2\delta$. As before, set $\Lambda = \Omega \times \mathbb{R}$.

Let $\gamma_1, \gamma_2 \in (0, \pi)$ satisfy

$$(1) \quad |\gamma_1 + \gamma_2 - \pi| \leq 2\alpha \quad \text{and} \quad |\gamma_1 - \gamma_2| > \pi - 2\alpha;$$

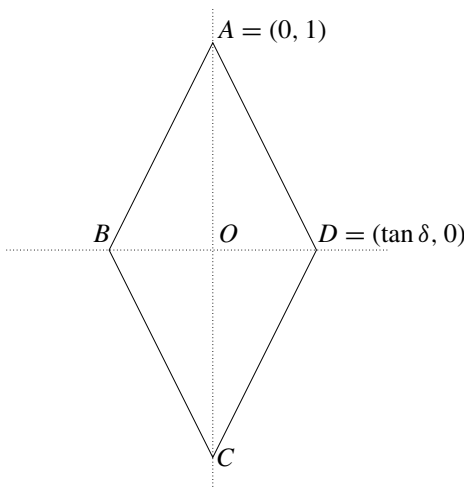

Figure 2. The quadrilateral domain Ω with $OAB = \delta$.

this is equivalent to saying that $(\gamma_1, \gamma_2) \in D_2^+(2\alpha) \cup D_2^-(2\alpha)$. Define the function $\gamma : \partial\Omega \rightarrow \mathbb{R}$ by

$$\gamma(x, y) = \begin{cases} \gamma_1 & \text{if } (x, y) \in AB, \\ \gamma_2 & \text{if } (x, y) \in BC, \\ \pi - \gamma_2 & \text{if } (x, y) \in CD, \\ \pi - \gamma_1 & \text{if } (x, y) \in DA. \end{cases}$$

We now formally define the capillary problem in the cylinder Λ with contact angle boundary data γ , gravitational constant $\kappa \geq 0$ and Lagrange multiplier λ . By a solution of this problem, we mean a function $h : \Omega \rightarrow \mathbb{R}$ with

$$h \in C^2(\Omega) \cap C^1(\bar{\Omega} \setminus \{A, B, C, D\})$$

which satisfies

$$(2) \quad \begin{aligned} \operatorname{div}(Th) &= \kappa h + \lambda && \text{in } \Omega, \\ Th \cdot \mathbf{v} &= \cos \gamma && \text{on } \partial\Omega \setminus \{A, B, C, D\}, \end{aligned}$$

where \mathbf{v} is the outer unit normal to $\partial\Omega$ and

$$Th = \frac{\nabla h}{\sqrt{1 + |\nabla h|^2}},$$

as in [Finn 1986]. We are interested in the behavior of the solution in zero gravity, $\kappa = 0$. In this case the divergence theorem together with (2) implies

$$\lambda|\Omega| = \int_{\Omega} \operatorname{div}(Th) \, dA = \int_{\partial\Omega} \cos \gamma \, ds.$$

Since $\cos \gamma(x, y)$ is an odd function of x , we see that $\lambda = 0$. This means a solution h will be a minimal surface. The contact angles from each side at B are γ_1 and γ_2 and at D are $\pi - \gamma_2$ and $\pi - \gamma_1$. Our principal interest is in the behavior of solutions at B and D and our proof will focus on the behavior of solutions at B .

Theorem 1.1. *Suppose $\gamma_1, \gamma_2 \in (0, \pi)$ satisfy (1). Let Ω and γ be as defined above. There exists a unique solution $h \in C^2(\Omega) \cap C^0(\bar{\Omega} \setminus \{A, B, C, D\})$ of the boundary value problem (2) with $\kappa = \lambda = 0$ which satisfies $h(0, 0) = 0$. This solution is discontinuous at B and D , continuous at A if and only if $|\gamma_1 - \pi/2| \leq \pi/2 - \delta$, and continuous at C if and only if $|\gamma_2 - \pi/2| \leq \pi/2 - \delta$.*

To prove this theorem, we first isolate and prove the most difficult case:

Lemma 1.2. *Suppose $\gamma_1 \in [\delta, \pi/2]$ and $\gamma_2 \in [\pi/2, \pi - \delta]$ satisfy (1). Let Ω and γ be as above. There exists a unique solution*

$$h \in C^2(\Omega) \cap C^0(\bar{\Omega} \setminus \{B, D\})$$

of the boundary value problem (2) with $\kappa = \lambda = 0$ which satisfies $h(0, 0) = 0$. This solution h is discontinuous at B and D .

One accomplishment in this paper is that it provides an example of a capillary surface for each corner angle $2\alpha = \pi - 2\delta \in (\pi/2, \pi)$ and each pair of contact angles in the regions $D_2^\pm(\pi - 2\delta)$ in which the validity of the Concus–Finn conjecture is unknown. The Concus–Finn conjecture is the principal outstanding open problem in the mathematical theory of capillarity. To the best of our knowledge, there is only one paper [Huff and McCuan 2006] that provides examples of capillary surfaces with data in the D_2^\pm regions and in which the continuity of the nonparametric capillary surface at the corner is determined; it considers contact angle data only along the line $\gamma_1 + \gamma_2 = \pi$. We give here, then, the first collection of examples corresponding to all of the contact angle pairs in $D_2^\pm(\pi - 2\delta)$ in which the continuity at the corner is determined, and in these examples the Concus–Finn conjecture correctly predicts the behavior at B and D of these capillary surfaces.

2. Proof of Lemma 1.2

Assume the hypotheses of Lemma 1.2 hold. We then know from (1) that $\gamma_2 - \gamma_1 > 2\delta$. We begin by assuming

$$\gamma_1 < \pi/2 < \gamma_2, \quad \text{that is,} \quad \gamma_1, \gamma_2 \neq \pi/2.$$

Let Ω_0 be the portion of Ω in $\{x < 0\}$, so that $\partial\Omega_0$ is the triangle with successive vertices A, B and C . Let $B_1 = \{w \in \mathbb{C} : |w| < 1\}$ and set

$$E_0 = \{w \in B_1 : \text{Im } w > 0, |w - w_1| > \tan \gamma_1, |w - w_3| > \tan(\pi - \gamma_2)\},$$

where

$$w_1 = u_1 + i v_1 = -\cos \delta \sec \gamma_1 + i \sin \delta \sec \gamma_1,$$

$$w_3 = u_3 + i v_3 = \cos \delta \sec(\pi - \gamma_2) + i \sin \delta \sec(\pi - \gamma_2).$$

Also set $r_1 = \tan \gamma_1$ and $r_3 = \tan(\pi - \gamma_2)$. Let $E = \bar{E}_0$ (Figure 3). We remark that E will eventually be shown to be the image of the stereographic projection of the Gauss map to the (closure of the) graph of the nonparametric solution h over $\bar{\Omega}_0$ when this graph is given a downward orientation. Now E is a connected, simply connected subset of the closed unit disk which is star-like with respect to the origin. The boundary of E consists of portions of the circles

$$C_1 = \{w : |w - w_1| = \tan \gamma_1\} \quad \text{and} \quad C_3 = \{w : |w - w_3| = \tan(\pi - \gamma_2)\}$$

(which are orthogonal to the unit circle ∂B_1), the real axis ($v = 0$) and the unit half-circle $\{w \in \partial B_1 : \text{Im } w \geq 0\}$. The condition $\gamma_2 - \gamma_1 > 2\delta$ implies (and is actually equivalent to) $C_1 \cap C_3 = \emptyset$.

Write

$$\sigma_1 = \partial E \cap C_1, \quad \sigma_2 = \{w \in \partial E : \text{Im}(w) = 0\},$$

$$\sigma_3 = \partial E \cap C_3, \quad \sigma_4 = \partial E \cap \partial B_1.$$

We denote the corners of ∂E (in counterclockwise order) as t_1, t_2, t_3 and t_4 , with $t_1, t_2 \in \sigma_1, t_3, t_4 \in \sigma_3, t_1, t_4 \in \partial B_1$ and $\text{Im } t_2 = \text{Im } t_3 = 0$. Notice that $t_1 = e^{(\pi - \delta - \gamma_1)i}$ and $t_4 = e^{(\delta + \pi - \gamma_2)i}$.

Our numbering scheme, associating center w_3 and circle C_3 with the cylinder side BC whose prescribed contact angle is γ_2 , is chosen because it provides a clearer and more consistent notation for the Riemann–Hilbert problem we will consider later. There is no “second” circle C_2 (unless one wishes to consider the

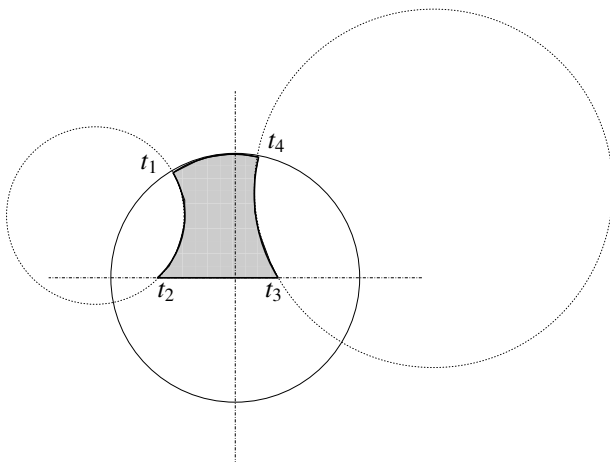

Figure 3. The region E .

line $v = 0$ to be a circle with infinite radius) and no “second” center w_2 . If we wished to introduce a fourth circle, we would set $C_4 = \partial B_1$ and $w_4 = 0$.

Define $g : E \rightarrow E$ by $g(w) = w$. Our goal is to find $f \in C^0(E \setminus \{t_1, \dots, t_4\})$ with, at worst, integrable singularities at t_1, t_2, t_3 , and t_4 which is analytic in E_0 and to define $X \in C^0(E : \mathbb{R}^3) \cap C^2(E_0 : \mathbb{R}^3)$ with

$$(3) \quad X(u + iv) = (x(u, v), y(u, v), z(u, v))$$

and $K(u + iv) = (x(u, v), y(u, v))$ for $u + iv \in E$, satisfying certain conditions:

- (i) The analytic functions (f, g) form the Weierstrass representation of X (see [Osserman 1969], for instance, or [Huff 2006] in this volume).
- (ii) K is a homeomorphism between σ_1 and the line segment AB , between σ_2 and AC , and between σ_3 and BC .
- (iii) K is constant on σ_4 .

Here we say f has an integrable singularity at t_k if and only if $|f(w)| \leq C|w - t_k|^s$ with $-1 < s < 0$ and $C \geq 0$ for w near t_k . Notice that $f \equiv 0$ corresponds to a “surface” consisting of a single point, as in (5) below, and therefore does not yield a solution of (2).

We now formulate the Riemann–Hilbert problem which we will solve by temporarily assuming the existence of a suitable function f .

The boundary requirements (ii) imply

$$(4) \quad \begin{cases} y(u, v) = \cot \delta x(u, v) + 1 & \text{for } u + iv \in \sigma_1, \\ x(u, v) = 0 \text{ and } 0 \leq y(u, v) \leq 1 & \text{for } u + iv \in \sigma_2, \\ y(u, v) = -\cot \delta x(u, v) - 1 & \text{for } u + iv \in \sigma_3. \end{cases}$$

Write $f(u + iv) = f_1(u, v) + if_2(u, v)$, where f_1 and f_2 are real-valued.

Now (i) implies

$$(5) \quad \begin{cases} x_w = f(w)(1 - w^2)/2, \\ y_w = if(w)(1 + w^2)/2, \\ z_w = wf(w); \end{cases}$$

for $w \in E$; see [Elcrat and Lancaster 1989, p. 1061], for example. Since $d/dw = \frac{1}{2}(\partial/\partial u - i\partial/\partial v)$, the equations above yield

$$(6) \quad \begin{aligned} x_u(u, v) &= \operatorname{Re}(f(w)(1 - w^2)) = (1 - u^2 + v^2)f_1 + 2uvf_2, \\ x_v(u, v) &= -\operatorname{Im}(f(w)(1 - w^2)) = 2uvf_1 - (1 - u^2 + v^2)f_2, \end{aligned}$$

$$(7) \quad \begin{aligned} y_u(u, v) &= \operatorname{Re}(if(w)(1+w^2)) = -2uvf_1 - (1+u^2-v^2)f_2, \\ y_v(u, v) &= -\operatorname{Im}(if(w)(1+w^2)) = -(1+u^2-v^2)f_1 + 2uvf_2, \end{aligned}$$

and

$$(8) \quad \begin{aligned} z_u(u, v) &= \operatorname{Re}(2wf(w)) = 2(uf_1 - vf_2), \\ z_v(u, v) &= -\operatorname{Im}(2wf(w)) = 2(-vf_1 - uf_2), \end{aligned}$$

where we use the notation $w = u + iv$. If we parametrize $\sigma_k, k = 1, \dots, 4$, as

$$\sigma_k = \{w_k(t) = u_k(t) + iv_k(t)\},$$

we find that the equalities (4) imply, respectively,

$$\begin{aligned} y_u u'_1 + y_v v'_1 &= \cot \delta (x_u u'_1 + x_v v'_1), \\ x_u(u_2(t), 0) &= 0, \\ y_u u'_3 + y_v v'_3 &= -\cot \delta (x_u u'_3 + x_v v'_3), \end{aligned}$$

and that condition (iii) of the previous page implies

$$x_u u'_4 + x_v v'_4 = 0.$$

Now $(u_1(t) - u_1)^2 + (v_1(t) - v_1)^2 = r_1^2$ implies

$$\frac{u'_1(t)}{v'_1(t)} = -\frac{v_1(t) - v_1}{u_1(t) - u_1} = -\frac{\operatorname{Im}(w_1(t) - w_1)}{\operatorname{Re}(w_1(t) - w_1)}$$

and similarly for $u'_3(t)/v'_3(t)$. Recall that

$$\cot \delta = -\frac{\operatorname{Re} w_1}{\operatorname{Im} w_1} = -\frac{u_1}{v_1} \quad \text{and} \quad \cot \delta = \frac{\operatorname{Re} w_3}{\operatorname{Im} w_3} = \frac{u_3}{v_3}.$$

If we rewrite x_u, \dots, z_v in terms of f, u and v , we obtain

$$(9) \quad \operatorname{Re}((a_k(u, v) + ib_k(u, v))f(u + iv)) = 0$$

when $(u, v) \in \sigma_k$, which we could also write as

$$a_k(u, v)f_1(u, v) - b_k(u, v)f_2(u, v) = 0,$$

for $k = 1, \dots, 4$, where

$$\begin{aligned} a_1(u, v) + ib_1(u, v) &= ie^{i\delta}(w - w_1)(e^{-2\delta i} - w^2) && \text{if } w = u + iv \in \sigma_1, \\ a_2(u, v) + ib_2(u, v) &= -1 && \text{if } u + iv \in \sigma_2, \\ a_3(u, v) + ib_3(u, v) &= ie^{-i\delta}(w - w_3)(e^{2\delta i} - w^2) && \text{if } w = u + iv \in \sigma_3, \\ a_4(u, v) + ib_4(u, v) &= (u + iv)^2 && \text{if } w = u + iv \in \sigma_4. \end{aligned}$$

We now define $a, b : \partial E \rightarrow \mathbb{R}$ by $a(u + iv) = a_k(u, v)$ and $b(u + iv) = b_k(u, v)$ if $u + iv \in \sigma_k$, for $k \in \{1, \dots, 4\}$, and define $G : \partial E \rightarrow \mathbb{C}$ by

$$G(w) = a(w) + ib(w).$$

We wish to find a function $f \in C^0(E \setminus \{t_1, \dots, t_4\})$ which is analytic in E_0 and satisfies

$$\operatorname{Re}(G(w)f(w)) = 0 \quad \text{for } w \in \partial E \setminus \{t_1, \dots, t_4\}.$$

This is a Riemann–Hilbert problem with discontinuous coefficients G ; in the notation of [Monakhov 1983, Chapter 1, §4], this is a “Hilbert problem with piecewise Hölder coefficients” (see also [Athanasenas and Lancaster 2004]). In order to use the results in [Monakhov 1983], we need to compute the index of this Hilbert problem in an appropriate function class $O(m) = O(t_{k_1}, \dots, t_{k_m})$ for some $m \in \{0, \dots, 4\}$. Define $G_1 : \partial E \rightarrow \mathbb{C}$ by

$$G_1(w) = -\frac{\overline{G(w)}}{G(w)}.$$

Notice that $G_1(w) = -1$ for $w \in \sigma_2$ and $G_1(w) = -(\bar{w}/|w|)^4 = -\bar{w}^4$ for $w \in \sigma_4$. Set $\omega = e^{i\delta}$. Moreover

$$\begin{aligned} G_1(w) &= |G(w)|^{-2} e^{-2\delta i} (\bar{w} - \bar{w}_1)^2 (\omega^2 - \bar{w}^2)^2 \\ &= |G(w)|^{-2} e^{-2\delta i} (\bar{w} - \bar{w}_1)^2 (\omega - \bar{w})^2 (\omega + \bar{w})^2 \quad \text{for } w \in \sigma_1, \\ G_1(w) &= |G(w)|^{-2} e^{2\delta i} (\bar{w} - \bar{w}_3)^2 (\bar{\omega} - \bar{w})^2 (\bar{\omega} + \bar{w})^2 \quad \text{for } w \in \sigma_3. \end{aligned}$$

For $k \in \{1, \dots, 4\}$, set

$$\theta_k = \frac{1}{2\pi} (\arg G_1(t_k - 0) - \arg G_1(t_k + 0)),$$

where $\arg G_1(t_k - 0)$ means the limit at t_k of the argument of G_1 along the arc σ_{k-1} (with σ_0 here being σ_4) and $\arg G_1(t_k + 0)$ means the limit at t_k of the argument of G_1 along the arc σ_k . The argument is taken to be continuous along each component of each set σ_k . We have

$$\begin{aligned} \arg G_1(t_1 - 0) &= -\pi + 4\gamma_1 + 4\delta, & \arg G_1(t_1 + 0) &= 4\gamma_1 + 4\delta - 2\pi, \\ \arg G_1(t_2 - 0) &= -2(\delta + \tau_{1B} + \lambda_{1B}), & \arg G_1(t_2 + 0) &= \pi, \\ \arg G_1(t_3 - 0) &= \pi, & \arg G_1(t_3 + 0) &= 2\delta - 2(\tau_{2B} + \lambda_{2B}), \\ \arg G_1(t_4 - 0) &= 4\pi - 4\gamma_2 - 4\delta, & \arg G_1(t_4 + 0) &= 3\pi - 4\gamma_2 - 4\delta. \end{aligned}$$

Here $t_2 = w_1 + r_1 e^{i\tau_{1B}}$ for some $\tau_{1B} \in [-\pi/2, -\delta)$, $t_3 = w_2 + r_2 e^{i\tau_{2B}}$ for some $\tau_{2B} \in (\delta - \pi, -\pi/2]$, $\bar{\omega}^2 - t_2^2 = |\bar{\omega}^2 - t_2^2| e^{i\lambda_{1B}}$ for some $\lambda_{1B} \in [-\pi/2 - \delta, -2\delta)$

and $\omega^2 + t_3^2 = |\omega^2 + t_3^2| e^{i\lambda_{2B}}$ for some $\lambda_{2B} \in (2\delta, \pi/2 + \delta]$. This implies

$$\theta_1 = \frac{1}{2}, \quad \theta_4 = \frac{1}{2}, \quad \frac{2\delta}{\pi} - \frac{1}{2} < \theta_2 \leq \frac{1}{2} \quad \text{and} \quad \frac{2\delta}{\pi} - \frac{1}{2} < \theta_3 \leq \frac{1}{2}.$$

We set $\nu_1 = \nu_2 = \nu_3 = \nu_4 = 0$. Consider $k \in \{2, 3\}$. If $\theta_k \in (-1, 0)$, the solution f of our Hilbert problem will be unbounded and have an integrable singularity at t_k while if $\theta_k \in (0, 1)$, f will be continuous and vanish at t_k ; if $\theta_k = 0$, f will be continuous and nonzero at t_k . Let $n \in \{0, 1, 2\}$ be the sum of the greatest integer function of θ_2 and of θ_3 and set $m = 4 - n$. A function in the function class $O(m)$ is an analytic function in E_0 which is continuous at each point of \bar{E} except possibly at the corners $\{t_1, \dots, t_4\}$ of ∂E , does not vanish on $E \setminus \{t_1, \dots, t_4\}$, is continuous at m of the corners and vanishes at some or all of these corners and has an integrable singularity at the remaining $4 - m$ corners. The index of our Hilbert problem in $O(m)$ is $\kappa = \nu_1 + \dots + \nu_4 = 0$ [Monakhov 1983, page 49] and our problem has a ‘‘canonical’’ solution F in $O(m)$ which is continuous at t_1 and t_4 and possibly at t_2 or t_3 [Monakhov 1983, pp. 42–53]. The general form of any solution (in $O(m)$) is $c_0 F(w)$ for any $c_0 \in \mathbb{R}$. Equation (9) with $k = 2$ implies $\text{Re } F = 0$ on σ_2 ; since F is nonvanishing on $E \setminus \{t_1, t_2, t_3, t_4\}$, $\text{Im } F$ is either strictly positive or strictly negative on the entire open interval $\sigma_2 \setminus \{t_2, t_3\}$. Let us select c_1 by requiring

$$(10) \quad c_1 \int_{t_2}^{t_3} (1 + u^2) \text{Im } F(u) \, du = -2$$

(recall that $\text{Im } t_2 = \text{Im } t_3 = 0$). We now define $f(u + iv) = f_1(u, v) + if_2(u, v)$ to be $c_1 F(u + iv)$.

Any two (complex) functions analytic on and without common zeros in the same simply connected domain in \mathbb{C} can be used to form a (parametric) minimal surface whose components will satisfy (5). Let $X \in C^0(E) \cap C^2(E_0)$ be the minimal surface with Weierstrass representation (f, g) which satisfies $X(0) = (0, y_0, 0)$ for some y_0 to be determined. Let us use the notation in (3) and define $K(u + iv) = (x(u, v), y(u, v))$. Recall that the image E of g is star-like with respect to the origin. Using, for example, [Nitsche 1989], we see that X is strictly monotonic on ∂E .

If $u + iv \in \sigma_2$, then $v = 0$ and $u \in [t_2, t_3]$. For $u \in [t_2, t_3]$, (7) implies

$$y(u, 0) - y_0 = \int_0^u (1 + s^2) f_2(s) \, ds$$

and (10) yields $y(t_3, 0) - y(t_2, 0) = -2$. Now set $y_0 = -1 - \int_0^{t_3} (1 + s^2) f_2(s) \, ds$, so that $y(t_3, 0) = -1$ and therefore $y(t_2, 0) = 1$. From (9) with $k = 2$, we have $(-1)f_1(u, v) + (0)f_2(u, v) = 0$ and so $f_1(u, v) = 0$ for $u + iv \in \sigma_2$. Now (6)

and (8) imply $x_u(u, 0) = 0$ and $z_u(u, 0) = 0$, so x and z are constant on σ_2 . Since $x(0, 0) = z(0, 0) = 0$, we see that X and K map σ_2 strictly monotonically onto AC .

If $u + iv \in \sigma_4$, then $u + iv = e^{i\theta}$ for some $\theta \in (0, \pi)$. Writing $u = u(\theta) = \cos \theta$ and $v = v(\theta) = \sin \theta$, we have

$$\begin{aligned} \frac{d}{d\theta}(x(u(\theta), v(\theta))) &= -vx_u(u, v) + ux_v(u, v) \\ &= 2v((u^2 - v^2)f_1(u, v) - 2uvf_2(u, v)) = 0, \\ \frac{d}{d\theta}(y(u(\theta), v(\theta))) &= -vy_u(u, v) + uy_v(u, v) \\ &= -2u((u^2 - v^2)f_1(u, v) - 2uvf_2(u, v)) = 0, \end{aligned}$$

since $a_4f_1 - b_4f_2 = 0$ on σ_4 . This implies x and y are constant on σ_4 . Thus K is constant on σ_4 .

Consider the behavior of K on σ_1 . Writing $u = u_1(t)$ and $v = v_1(t)$, we have

$$\begin{aligned} \frac{d}{dt}(y(u_1(t), v_1(t)) - \cot \delta x(u_1(t), v_1(t))) \\ = y_u u_1'(t) + y_v v_1'(t) - \cot \delta (x_u u_1'(t) + x_v v_1'(t)) = \frac{v_1'(t)}{u - u_1} (a_1 f_1 - b_1 f_2) = 0, \end{aligned}$$

so $y - \cot \delta x$ is constant on σ_1 . Since $y(t_2, 0) = 1$ and $x(t_2, 0) = 0$, we see that $y - \cot \delta x = 1$ on σ_1 and $K(t_2) = A$.

Now consider the behavior of K on σ_3 . Writing $u = u_3(t)$ and $v = v_3(t)$, we get

$$\begin{aligned} \frac{d}{dt}(y(u_3(t), v_3(t)) + \cot \delta x(u_3(t), v_3(t))) \\ = y_u u_3'(t) + y_v v_3'(t) - \cot \delta (x_u u_3'(t) + x_v v_3'(t)) = \frac{v_3'(t)}{u - u_3} (a_3 f_1 - b_3 f_2) = 0, \end{aligned}$$

so $y + \cot \delta x$ is constant on σ_3 . Since $y(t_3, 0) = -1$ and $x(t_3, 0) = 0$, we see that $y + \cot \delta x = -1$ on σ_3 and $K(t_3) = C$.

Since $K \in C^0(\partial E)$ and K is constant on σ_4 , $K(t_1) = K(t_4)$. Now $K(t_1)$ lies on the line $y = \cot \delta x + 1$ and $K(t_4)$ lies on the line $y = -\cot \delta x - 1$; hence $K(t_1) = K(t_4)$ must lie on the intersection of these lines, which is the point B . Therefore $K(t_1) = K(t_4) = B$, K maps σ_1 onto AB , and K maps σ_3 onto BC . Set

$$\Gamma = \{(x(u, v), y(u, v), z(u, v)) : u + iv \in \partial E\}.$$

Since Γ projects onto the convex triangle ABC and this projection is a bijection from $X(\partial E \setminus \sigma_4)$ onto $\partial\Omega_0 \setminus \{B\}$, $X(E \setminus \sigma_4)$ is the graph of a function

$$h \in C^2(\Omega_0) \cap C^0(\bar{\Omega}_0 \setminus \{B\}),$$

K maps E onto $\bar{\Omega}_0$ and $h(x(u, v), y(u, v)) = z(u, v)$ for $u + iv \in E \setminus \sigma_4$; in fact, $h \in C^1(\bar{\Omega}_0 \setminus \{B\})$; see, for example, [Nitsche 1989, §400, p. 349; Finn 1986]. Since $z(u, v) = 0$ if $u + iv \in \sigma_2$, $h = 0$ on AC .

We wish to demonstrate that the contact angle condition $Th \cdot \nu = \cos \gamma$ from (2) is satisfied on AB ; the demonstration that it is satisfied on BC is similar. Now the exterior unit normal $\nu \in \mathbb{R}^2$ to AB is $(-\cos \delta, \sin \delta)$ and the corresponding horizontal unit normal in \mathbb{R}^3 is $\eta = (-\cos \delta, \sin \delta, 0)$. Set $S = X(E)$. The downward unit normal (in \mathbb{R}^3) to S at $(x, y, h(x, y))$ is

$$\vec{N}(x, y) = \frac{(h_x(x, y), h_y(x, y), -1)}{\sqrt{1 + |\nabla h(x, y)|^2}}$$

and the Gauss map $\vec{G} : E \rightarrow S$ of X is given by $\vec{G}(u + iv) = \vec{N}(x(u, v), y(u, v))$ for $u + iv \in E \setminus \sigma_4$ and $\vec{G}(e^{i\theta}) = (\cos \theta, \sin \theta, 0)$ for $e^{i\theta} \in \sigma_4$. Recall that g is the stereographic projection of \vec{G} and C_1 is the stereographic projection of the circle $\{(u, v, t) \in S^2 : (u - u_1)^2 + (v - v_1)^2 + t^2 = r_1^2\}$, which can also be described as the intersection of the unit sphere with the cone $\{Y \in \mathbb{R}^3 : Y \cdot \eta = |Y| \cos \gamma_1\}$. We see therefore that $\vec{G}(w) \cdot \eta = \cos \gamma_1$ for $w \in \sigma_1$ and so

$$Th(x, y) \cdot \nu = \vec{N}(x, y) \cdot \eta = \vec{G}(w) \cdot \eta = \cos \gamma_1,$$

where $w = u + iv \in \sigma_1$ satisfies $(x(u, v), y(u, v)) = (x, y)$. Thus the contact angle condition is satisfied on the (open) interval AB .

We claim that h is discontinuous at B and, in fact, has a jump discontinuity at B . Using either [Lancaster and Siegel 1996] or the general maximum principle for minimal surfaces together with standard comparison surfaces, such as planes, we see that

$$\min\{z(t_1), z(t_4)\} \leq \liminf_{(x,y) \rightarrow B} h(x, y) \leq \limsup_{(x,y) \rightarrow B} h(x, y) \leq \max\{z(t_1), z(t_4)\},$$

where we have abused notation by, for example, writing $z(t_1)$ for $z(\operatorname{Re} t_1, \operatorname{Im} t_1)$. Since

$$\lim_{(x,y) \rightarrow B^+} h(x, y) = z(t_1) \quad \text{and} \quad \lim_{(x,y) \rightarrow B^-} h(x, y) = z(t_4),$$

where the first limit means approaching B along AB and the second limit means approaching B along BC , establishing this claim only requires us to prove that $z(t_1) \neq z(t_4)$. Now

$$\frac{d}{d\theta} z(\cos \theta, \sin \theta) = -2 \operatorname{Im}(w^2 f(w)),$$

and, from (9) with $k = 4$, we have $\operatorname{Re}(w^2 f(w)) = 0$, where $u = \cos \theta$, $v = \sin \theta$ and $w = u + iv$. Since f does not vanish on $\sigma_4 \setminus \{t_1, t_4\}$ and w does not vanish on σ_4 , the derivative $(d/d\theta)z(\cos \theta, \sin \theta)$ cannot vanish for any $\theta \in (\delta + \gamma_2, \pi - \delta - \gamma_1)$. Therefore $z(\cos \theta, \sin \theta)$ is either strictly increasing or strictly decreasing in θ for $\theta \in [\delta + \gamma_2, \pi - \delta - \gamma_1]$, so $z(t_1) \neq z(t_4)$.

We now define h on $\overline{\Omega}$ by extending the minimal surface $z = h(x, y)$ by reflection across the line segment $\{(0, y, 0) : |y| \leq 1\}$, so that $h \in C^0(\overline{\Omega} \setminus \{B, D\})$ and $h(x, y)$ is an odd function of x . Then the condition $Th \cdot \nu = \cos \gamma$ is satisfied at each point of $\partial\Omega \setminus \{A, B, C, D\}$. Since h is discontinuous at B , it is also discontinuous at D .

Suppose that $z = h_1(x, y)$ is any solution of the capillary problem with $h_1(0, 0) = 0$. Using the comparison principle for capillary surfaces [Finn 1986; Finn and Hwang 1989], we see that $h_1 = h + C$ for some constant C . Since $h_1(0, 0) = 0 = h(0, 0)$, we see that $h_1 = h$. Notice that h has the boundary behavior described in Theorem 1.1.

Suppose that $\gamma_1 < \pi/2$ and $\gamma_2 = \pi/2$. The arguments above continue to hold, but now $E = \overline{E}_0$, with

$$E_0 = \{w \in B_1 : \text{Im } w > 0, |w - w_1| > \tan \gamma_1, \text{Re } \bar{w} w < 0\},$$

as in Figure 4; recall that $\omega = e^{\delta i}$. The case in which $\gamma_1 = \pi/2$ and $\gamma_2 > \pi/2$ is similar.

3. Proof of Theorem 1.1

Consider $\gamma_1 \in (0, \pi/2]$ and $\gamma_2 \in [\pi/2, \pi)$ satisfying (1) and such that one of the following cases holds:

- (11) $\gamma_1 \in (0, \delta)$ and $\gamma_2 \in [\pi/2, \pi - \delta]$;
- (12) $\gamma_1 \in [\delta, \pi/2]$ and $\gamma_2 \in (\pi - \delta, \pi)$;
- (13) $\gamma_1 \in (0, \delta)$ and $\gamma_2 \in (\pi - \delta, \pi)$.

Together with the results of Lemma 1.2, the proof that our stated conclusions hold in these three cases will complete the proof of Theorem 1.1 when $\gamma_1 \in (0, \pi/2]$

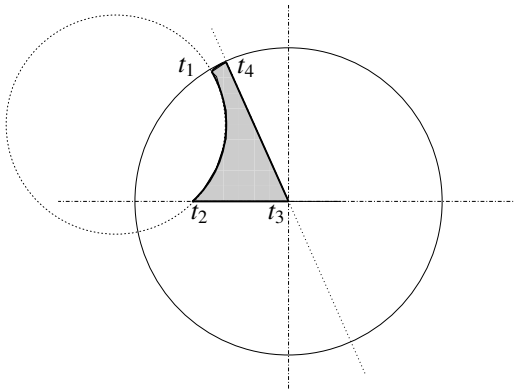

Figure 4. The domain E in the case $\gamma_2 = \pi/2$.

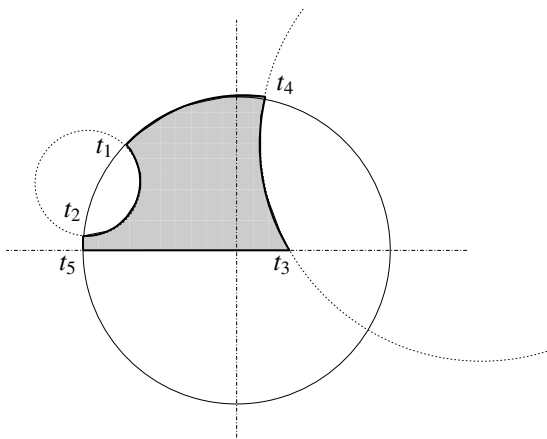

Figure 5. The domain E in the case $\gamma_1 \in (0, \delta)$, $\gamma_2 \in [\pi/2, \pi - \delta]$.

and $\gamma_2 \in [\pi/2, \pi)$. By reflecting Ω about the y -axis (or by considering the contact angles near D), we see that the situation where $\gamma_2 \in (0, \pi/2]$ and $\gamma_1 \in [\pi/2, \pi)$ will also be covered.

We begin by assuming that (11) holds. Then σ_4 has two components and E , which is illustrated in Figure 5, has an extra corner at $t_5 = -1$. We will continue to use the notation introduced in the proof of Lemma 1.2. Then

$$t_1 = e^{(\pi - \delta - \gamma_1)i}, \quad t_2 = e^{(\pi - \delta + \gamma_1)i},$$

and t_3 and t_4 are the same as in the previous section (see Figure 3). That we know t_2 explicitly makes our work here easier. The functions $G(w)$ and $G_1(w)$ remain the same and we wish to find $f \in C^0(E \setminus \{t_1, \dots, t_5\})$ analytic in E_0 and satisfying $\text{Re}(G(w)f(w)) = 0$ for $w \in \{t_1, \dots, t_5\}$. A little work shows that θ_1, θ_3 and θ_4 remain as before and

$$\begin{aligned} \arg G_1(t_2 - 0) &= 2\pi + 4\delta - 4\gamma_1, & \arg G_1(t_2 + 0) &= -3\pi + 4\delta - 4\gamma_1, \\ \arg G_1(t_5 - 0) &= -3\pi, & \arg G_1(t_5 + 0) &= \pi, \end{aligned}$$

so $\theta_2 = \frac{5}{2}$ and $\theta_5 = -2$. Set $v_1 = 0, v_2 = 2, v_3 = 0, v_4 = 0, v_5 = -2$ and $\alpha_k = \theta_k - v_k, 1 \leq k \leq 5$. If we select $c_1 \in \mathbb{R}$ such that

$$c_1 \int_{-1}^{t_3} (1 + u^2) \text{Im } F(u) \, du = -2,$$

where $F(w)$ is a ‘‘canonical solution’’ as in Section 2, the argument used there shows that there is a unique solution $h \in C^2(\Omega) \cap C^0(\bar{\Omega} \setminus \{A, B, D\})$ of (2) and this solution is discontinuous at A, B and D . If $\gamma_2 = \pi/2$, then E is modified as in the previous section (see Figure 4) and this conclusion continues to be valid.

Case (12) is similar to case (11), with corners at t_1, t_2, t_3, t_4 and $t_6 = 1$. Here θ_1, θ_2 and θ_4 are as in Section 2 and $\theta_3 = \frac{1}{2}, \theta_6 = \frac{1}{2}$. We leave this case as an exercise for the reader.

Suppose case (13) holds. Then E has six corners (with $t_5 = -1$ and $t_6 = 1$) and

$$\theta_1 = \frac{1}{2}, \quad \theta_2 = \frac{5}{2}, \quad \theta_3 = \frac{1}{2}, \quad \theta_4 = \frac{1}{2}, \quad \theta_5 = -2, \quad \theta_6 = \frac{1}{2}.$$

If we set $v_1 = 0, v_2 = 2, v_3 = 0, v_4 = 0, v_5 = -2$ and $v_6 = 0$, then our conclusions follow as in case (a).

It remains to show that our claims are true when (1) hold and γ_1 and γ_2 are both in $(0, \pi/2)$ (or both are in $(\pi/2, \pi)$). Let us assume $\gamma_1, \gamma_2 \in (0, \pi/2)$ satisfy (1) with $\gamma_1 - \gamma_2 > 2\delta$. We redefine w_3 and r_3 by

$$w_3 = u_3 + i v_3 = -\cos \delta \sec \gamma_2 - i \sin \delta \sec \gamma_2 \quad \text{and} \quad r_3 = \tan \gamma_3.$$

We set $E = \bar{E}_0$, where

$$E_0 = \{w \in B_1 : \text{Im } w < 0, |w - w_1| < r_1, |w - w_3| < r_3\}.$$

Let C_3 denote the circle $|w - w_3| = r_3$ and set

$$\begin{aligned} \sigma_1 &= \partial E \cap C_1, & \sigma_2 &= \{w \in \partial E : \text{Im } w = 0\}, \\ \sigma_3 &= \partial E \cap C_2, & \sigma_4 &= \partial E \cap \partial B_1. \end{aligned}$$

We have two cases to consider: $\gamma_2 < \delta$ and $\gamma_2 \geq \delta$. The situation can then be taken to be as in the left and right panels, respectively, of Figure 6. For if we can obtain our desired conclusions in these two situations, we will have proved that Theorem 1.1 is valid in one of the four triangular regions remaining where (1) is

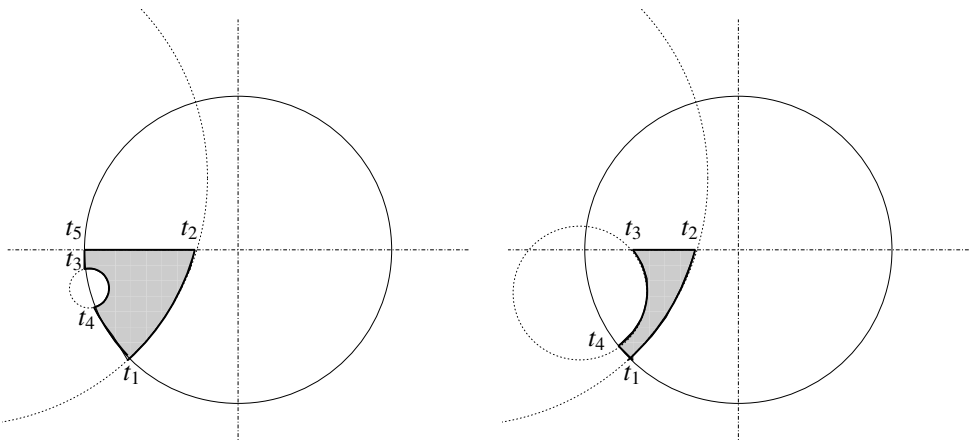

Figure 6. The domain E in the case $\gamma_1 \in (0, \delta), \gamma_2 \in (\pi - \delta, \pi)$. Left: $\gamma_2 < \delta$; right: $\gamma_2 \geq \delta$.

satisfied. The validity of [Theorem 1.1](#) in the other three regions will then follow by symmetry and/or the interchange of γ_1 and γ_2 .

Suppose $\gamma_2 < \delta$, and refer to [Figure 6](#), left. Denote the corners of E by t_1, \dots, t_5 , where

$$t_1 = e^{(\pi-\delta+\gamma_1)i}, \quad t_3 = e^{(\pi+\delta-\gamma_2)i}, \quad t_4 = e^{(\pi+\delta+\gamma_2)i}, \quad t_5 = -1$$

and $t_2 \in \sigma_1$ with $\text{Im } t_2 = 0$. The functions $G(w)$ and $G_1(w)$ remain the same as in [Section 2](#) (using our redefined w_3 and r_3). Then

$$\begin{aligned} \arg G_1(t_1 - 0) &= -3\pi + 4(\delta - \gamma_1), & \arg G_1(t_1 + 0) &= 3\pi + 4(\delta - \gamma_1), \\ \arg G_1(t_2 - 0) &= -2(\delta + \tau_{1B} + \lambda_{1B}), & \arg G_1(t_2 + 0) &= \pi, \\ \arg G_1(t_3 - 0) &= -3\pi - 4(\delta - \gamma_2), & \arg G_1(t_3 + 0) &= 4(\gamma_2 - \delta), \\ \arg G_1(t_4 - 0) &= 2\pi - 4(\gamma_2 + \delta), & \arg G_1(t_4 + 0) &= -3\pi - 4(\gamma_2 + \delta), \\ \arg G_1(t_5 - 0) &= \pi, & \arg G_1(t_5 + 0) &= -3\pi, \end{aligned}$$

where $t_2 = w_1 + r_1 e^{i\tau_{1B}}$ for some $\tau_{1B} \in [-\pi/2, -\delta)$ and $\omega^2 - t_2^2 = |\omega^2 - t_2^2| e^{i\lambda_{1B}}$ for some $\lambda_{1B} \in [-\pi/2 - \delta, -2\delta)$ as in [Section 2](#). Then

$$\theta_1 = -3, \quad \theta_2 = -\frac{1}{2} - \frac{\delta + \tau_{1B} + \lambda_{1B}}{\pi}, \quad \theta_3 = -\frac{3}{2}, \quad \theta_4 = \frac{5}{2}, \quad \theta_5 = 2.$$

Set $v_1 = -3, v_2 = 0, v_3 = -1, v_4 = 2, v_5 = 2$ and $\alpha_k = \theta_k - v_k, 1 \leq k \leq 5$. Since $v_1 + v_2 + v_3 + v_4 + v_5 = 0$, we may argue as before and obtain a unique solution $h \in C^2(\Omega) \cap C^0(\bar{\Omega} \setminus \{B, C, D\})$ of [\(2\)](#); this solution is discontinuous at B, C, D .

Suppose $\gamma_2 \geq \delta$, and refer to [Figure 6](#), right. Let the corners of E be denoted by t_1, \dots, t_4 , where t_1, t_2 and t_4 are as in the previous case and $t_3 \in \sigma_3$ with $\text{Im } t_3 = 0$. If we write $t_3 = w_3 + r_3 e^{i\tau_{2B}}$ for some $\tau_{2B} \in (\delta, \pi/2]$ and $\omega^2 - t_3^2 = |\omega^2 - t_3^2| e^{i\lambda_{2B}}$ for some $\lambda_{2B} \in (2\delta, \pi/2 + \delta]$, then we find

$$\theta_1 = -3, \quad \theta_2 = -\frac{1}{2} - \frac{\delta + \tau_{1B} + \lambda_{1B}}{\pi}, \quad \theta_3 = \frac{1}{2} + \frac{\tau_{2B} + \lambda_{2B} - \delta}{\pi}, \quad \theta_4 = \frac{5}{2}.$$

Set $v_1 = -3, v_2 = 0, v_3 = 1, v_4 = 2$ and $\alpha_k = \theta_k - v_k, 1 \leq k \leq 4$. Then there is a unique solution $h \in C^2(\Omega) \cap C^0(\bar{\Omega} \setminus \{B, D\})$ of [\(2\)](#) and this solution is discontinuous at B and D .

References

[Athanasenas and Lancaster 2004] M. Athanasenas and K. Lancaster, “CMC capillary surfaces at reentrant corners”, preprint, 2004.
 [Concus and Finn 1991] P. Concus and R. Finn, “On a comment by J. P. B. Vreeburg”, *Microgravity Sci. Tech.* **4** (1991), 60.
 [Concus and Finn 1994] P. Concus and R. Finn, “Capillary surfaces in a wedge: differing contact angles”, *Microgravity Sci. Tech.* **7:2** (1994), 152–155.

- [Concus and Finn 1996] P. Concus and R. Finn, “Capillary wedges revisited”, *SIAM J. Math. Anal.* **27**:1 (1996), 56–69. [MR 96m:76006](#) [Zbl 0843.76012](#)
- [Elcrat and Lancaster 1989] A. R. Elcrat and K. E. Lancaster, “Bernstein functions and the Dirichlet problem”, *SIAM J. Math. Anal.* **20**:5 (1989), 1055–1068. [MR 90e:53011](#) [Zbl 0699.35095](#)
- [Finn 1986] R. Finn, *Equilibrium capillary surfaces*, Grundlehren der Math. Wissenschaften **284**, Springer, New York, 1986. [MR 88f:49001](#) [Zbl 0583.35002](#)
- [Finn 1996] R. Finn, “Local and global existence criteria for capillary surfaces in wedges”, *Calc. Var. Partial Differential Equations* **4**:4 (1996), 305–322. [MR 97f:53005](#) [Zbl 0872.76017](#)
- [Finn and Hwang 1989] R. Finn and J.-F. Hwang, “On the comparison principle for capillary surfaces”, *J. Fac. Sci. Univ. Tokyo Sect. IA Math.* **36** (1989), 131–134. [MR 90h:35099](#) [Zbl 0684.35007](#)
- [Huff 2006] R. Huff, “Minimal solutions to the local capillary wedge problem”, *Pacific J. Math.* **224**:2 (2006), 247–261.
- [Huff and McCuan 2006] R. Huff and J. McCuan, “Scherk-type capillary graphs”, *J. Math. Fluid Mech.* **8**:1 (2006), 99–119.
- [Lancaster and Siegel 1996] K. E. Lancaster and D. Siegel, “Existence and behavior of the radial limits of a bounded capillary surface at a corner”, *Pacific J. Math.* **176**:1 (1996), 165–194. Correction to figures, **179** (1997), 397–402. [MR 98g:58030a](#) [Zbl 0866.76018](#)
- [Monakhov 1983] V. N. Monakhov, *Boundary value problems with free boundaries for elliptic systems of equations*, Translations of Mathematical Monographs **57**, American Mathematical Society, Providence, RI, 1983. [MR 85a:35029](#) [Zbl 0532.35001](#)
- [Nitsche 1989] J. C. C. Nitsche, *Lectures on minimal surfaces*, vol. 1, Cambridge University Press, Cambridge, 1989. [MR 90m:49031](#) [Zbl 0688.53001](#)
- [Osserman 1969] R. Osserman, *A survey of minimal surfaces*, Van Nostrand, New York, 1969. Reprinted by Dover, New York, 1986. [MR 87j:53012](#) [Zbl 0209.52901](#)
- [Simon 1980] L. Simon, “Regularity of capillary surfaces over domains with corners”, *Pacific J. Math.* **88**:2 (1980), 363–377. [MR 82d:49043](#) [Zbl 0467.35022](#)
- [Tam 1986] L.-F. Tam, “Regularity of capillary surfaces over domains with corners: borderline case”, *Pacific J. Math.* **124**:2 (1986), 469–482. [MR 87k:49049](#) [Zbl 0604.49029](#)

Received June 25, 2004. Revised October 9, 2005.

JULIE CRENSHAW
DEPARTMENT OF MATHEMATICS AND STATISTICS
WICHITA STATE UNIVERSITY
WICHITA, KANSAS 67260-0033
UNITED STATES
crenshaw@math.wichita.edu

KIRK LANCASTER
DEPARTMENT OF MATHEMATICS AND STATISTICS
WICHITA STATE UNIVERSITY
WICHITA, KANSAS 67260-0033
UNITED STATES
lancaster@math.wichita.edu