

*Pacific  
Journal of  
Mathematics*

SPECTRAL ANALYSIS OF LAPLACIANS ON THE VICSEK SET

DENGLIN ZHOU

Volume 241 No. 2

June 2009



## SPECTRAL ANALYSIS OF LAPLACIANS ON THE VICSEK SET

DENGLIN ZHOU

**We find the spectral decimation function for the standard Laplacian on the symmetric Vicsek set, expressed in terms of Chebyshev polynomials. This allows us to determine the order of the eigenvalues of the Laplacian, describe their asymptotic behavior and prove that there exist gaps in the spectrum.**

### 1. Introduction

The Laplacian on the Vicsek set has been studied extensively in [Barlow 1998; Malozemov and Teplyaev 2003; Metz 1993; Shima 1996], both analytically and probabilistically. Various problems have been studied for this fractal, including topological rigidity [Strichartz 2006], the uniqueness of Brownian motion [Metz 1993], etc. In particular, Hambly and Metz [1998] investigated the homogenization problem on the infinite family of the Vicsek set. In this paper, we study the spectrum of the Laplacian on a special case of this infinite family of fractals, the symmetric  $n$ -branch Vicsek set  $\mathcal{V}\mathcal{S}_n$ . All eigenvalues of the Laplacian can be obtained through an iterative process called spectral decimation, which was introduced by Shima [1996]. It turns out that the spectral decimation function is associated with the Chebyshev polynomials.

Laplacians on fractals originated in physics literature, where the Laplacian was first defined on the Sierpiński gasket  $\mathcal{S}\mathcal{G}$  as the generator of a diffusion process [Goldstein 1987; Kusuoka 1987]. Kigami constructed the Laplacian analytically, both as a renormalized limit of difference operators and through a weak formulation using the theory of Dirichlet forms [Kigami 1989]. Later, the theory of Laplacians was extended to other fractals, including nested fractals and p.c.f. self-similar sets by Lindstrøm [1990] and Kigami [1993].

The spectra of the Laplacian operators on a number of fractals have been analyzed both numerically [Adams et al. 2003] and using the spectral decimation method [Drenning and Strichartz 2009; Malozemov and Teplyaev 2003; Shima 1996; Teplyaev 1998]. One interesting result is that there can be gaps in the spectra of the Laplacians. (For a given infinite sequence  $\alpha_1 \leq \alpha_2 \leq \cdots \leq \alpha_k \leq \cdots$ , we

---

*MSC2000:* primary 28A80, 42C99; secondary 31C25.

*Keywords:* analysis on fractals, spectral analysis, Vicsek set, Laplace operator.

say that there exist *gaps* in the sequence if  $\limsup_{k \geq 1} (a_{k+1}/a_k) > 1$ .) This result, together with a suitable heat kernel estimate, was used to show the corresponding Riesz theorem for Fourier series on fractals and to obtain the even stronger conclusion that the Fourier series converges for  $p = 1$  and converges uniformly when the function is continuous. (See [Strichartz 2005] for details.)

The existence of gaps was proved explicitly for the standard Laplacian on the Sierpiński gasket in [Gibbons et al. 2001] using results obtained by Fukushima and Shima [1992]. Later it was proved for the level-3 Sierpiński gasket in [Drenning and Strichartz 2009], and numerical data also suggested it was true for the Pentagasket [Adams et al. 2003]. More general criteria were proved in [Zhou 2008] where the Laplacians admit spectral decimation. In this paper, we show that one criterion in [Zhou 2008] applies to the Vicsek set family and therefore there exist gaps in the spectrum. We also determine the ordering of all the eigenvalues and prove a Weyl-type theorem for the Vicsek set.

The paper is organized as follows. In Section 2, we briefly review the spectral decimation method. In Section 3, we determine the spectral decimation function and all forbidden eigenvalues for the Laplacian on the Vicsek set. In Section 4, we check that all conditions of Theorem 13 in [Zhou 2008] are met and so there exist gaps in the spectrum of the standard Laplacian. In Section 5, we determine the order of the spectrum of the Laplacian for the infinite family of the Laplacian. In Section 6, we show a Weyl-type theorem for  $\mathcal{V}\mathcal{G}_n$ .

## 2. Laplacian on fractals and spectral decimation method

In this section, we briefly review the way to define a Laplacian on p.c.f. fractals introduced by Kigami [1993], and the spectral decimation method developed by Shima [1996] to analyze its spectrum.

Let  $\mathbf{K}$  be a compact metrizable topological space and  $\mathcal{L} = \{\mathbf{K}, S, \{F_s\}_{s \in S}\}$  a self-similar structure, where  $S$  is a finite set and  $F_s$  is a continuous injection from  $\mathbf{K}$  to itself for every  $s \in S$ . We denote  $W_n(S) = S^n$  and  $W_*(S) = \bigcup_{n \geq 0} W_n(S)$ . For  $w = w_1 w_2 \cdots w_n \in W_n(S)$ , let  $F_w = F_{w_1} \circ F_{w_2} \circ \cdots \circ F_{w_n}$ , and  $\mathbf{K}_w = F_w \mathbf{K}$ . Assume that there exists a continuous surjection  $\pi : S^{\mathbb{N}} \rightarrow \mathbf{K}$  satisfying  $\pi \circ s = F_s \circ \pi$  for every  $s \in S$ , where  $s$  denotes the map from  $S^{\mathbb{N}}$  to  $S^{\mathbb{N}}$  defined by  $s(w_1 w_2 \cdots) = s w_1 w_2 \cdots$ . The *critical set*  $\mathcal{C}$  and *postcritical set*  $\mathcal{P}$  are defined respectively by

$$\mathcal{C} = \pi^{-1} \left( \bigcup_{s,t \in S, s \neq t} (\mathbf{K}_s \cap \mathbf{K}_t) \right), \quad \mathcal{P} = \bigcup_{n \geq 1} \sigma^n(\mathcal{C}),$$

where  $\sigma : S^{\mathbb{N}} \rightarrow S^{\mathbb{N}}$  is the left-shift map. A self-similar set is called *postcritically finite* (abbreviation p.c.f.) if and only if the postcritical set  $\mathcal{P}$  is finite.

We take  $G_0$  to be the complete graph on  $V_0$ , where  $V_0 = \pi(\mathcal{P})$  and is thought of as the boundary of  $\mathbf{K}$ . Then define the *set of vertices* by

$$V_m = \bigcup_s F_s V_{m-1}, \quad V_* = \bigcup_m V_m$$

and define the edge relation  $(x, y) \in E_m$  (or  $x \sim_m y$ ) to hold if there exists a word  $w$  of length  $|w| = m$  such that  $x, y \in F_w V_0$ . We denote by  $G_m = (V_m, E_m)$  the step- $m$  graph with vertices  $V_m$  and edges  $E_m$ . Kigami first defines a Laplacian operator on the vertices  $V_m$  as a difference operator. Take  $D$  to be a symmetric (Laplacian) matrix in  $L(V_0)$  with row sum zero, nonnegative off-diagonal entries and negative diagonal entries. Choose  $\mathbf{r} = (r_1^{-1}, r_2^{-1}, \dots, r_{|S|}^{-1}) \in \ell(S)$  and let  $r_0$  be the number such that  $r_0^{-1} = \sum_{s \in S} r_s^{-1}$ .

A *generalized/combinatorial Laplacian with weight  $\mathbf{r}$*  on  $V_m$ ,  $(H_m, \mathbf{r})$ , is defined as

$$(2-1) \quad H_m = \sum_{w \in W_m} r_w^{-1} R_w^t D R_w,$$

where  $R_w \in L(V_m, F_w(V_0))$  is the restriction map defined by  $R_w f = f|_{F_w(V_0)}$ , and  $r_w = r_{w_1} r_{w_2} \dots r_{w_m}$  for  $w = w_1 w_2 \dots w_m \in W_m$  [Kigami 1993]. The special case when all off-diagonal entries of  $D$  are 1 and all  $r_i = 1$  is called the *standard Laplacian*. Decompose  $H_m$  into

$$(2-2) \quad H_m = \begin{bmatrix} T_m & J_m^t \\ J_m & X_m \end{bmatrix},$$

where  $T_m \in L(V_0)$ ,  $J_m \in L(V_0, V_m^0)$  and  $X_m \in L(V_m^0)$ . In particular, write  $T = T_1$ ,  $J = J_1$  and  $X = X_1$ .

A *normalized Laplacian*,  $\widehat{\Delta}_m$ , can be obtained by first constructing a measure  $\widehat{\mu}_m$  on  $V_m$  as

$$\widehat{\mu}_m(x) = \left( \sum_{w \in W_m} r_w^{-1} R_w^t (-T) R_w \right)_{x,x},$$

and then setting

$$\widehat{\Delta}_m f(x) := \frac{H_m f(x)}{\widehat{\mu}_m(x)},$$

for  $f \in \ell(V_m)$  [Kigami 1993].

Assume the p.c.f. fractal  $\mathbf{K}$  is connected and

$$(2-3) \quad \#(F_s(V_0) \cap V_0) \leq 1 \text{ for every } s \in S.$$

Note the latter assumption implies that  $T$  is a diagonal matrix. Define diagonal matrices  $M$  and  $W$  such that

$$M_{i,i} = -X_{i,i} \quad \text{and} \quad W = \begin{bmatrix} -T & 0 \\ 0 & M \end{bmatrix}.$$

We also denote  $G(\lambda) = (X + \lambda M)^{-1}$  if the inverse matrix exists.

**Definition 1** [Shima 1996]. The generalized Laplacian  $(H_m, \mathbf{r})$  is said to have a *strong harmonic structure* if there exist rational functions  $K_D(\lambda)$  and  $K_T(\lambda)$  such that when  $X + \lambda M$  is invertible, then

$$(2-4) \quad T - J^t(X + \lambda M)^{-1}J = K_D(\lambda)D + K_T(\lambda)T.$$

$K_D(0)^{-1}$  is called the *energy renormalization constant*.

We set

$$\mathfrak{F} := \{\lambda \in \mathbb{R} : K_D(\lambda) = 0 \text{ or } \det(X + \lambda M) = 0\}$$

and call elements in  $\mathfrak{F}$  the *forbidden eigenvalues*. Moreover, we let

$$\mathfrak{F}_k := \{\lambda \in \mathfrak{F} : \lambda \text{ is an eigenvalue of } -\widehat{\Delta}_k\}$$

and call the elements in  $\mathfrak{F}_k$  the *forbidden eigenvalues at step k* or *initial eigenvalues at step k*. The rational function

$$R(\lambda) := \frac{\lambda - K_T(\lambda)}{K_D(\lambda)}$$

is called the *spectral decimation function*.

Suppose we are given a p.c.f. self-similar set (also satisfying our assumption (2-3)) and the generalized Laplacian has a strong harmonic structure. Then the normalized Laplacian has the following spectral decimation property proved by Shima.

**Proposition 2** [Shima 1996]. *Suppose the generalized Laplacian has a strong harmonic structure. We have the following collective results:*

- (1) *If  $f$  is an eigenfunction of  $-\widehat{\Delta}_{m+1}$  with eigenvalue  $\lambda$ , that is,  $-\widehat{\Delta}_{m+1}f = \lambda f$ , and  $\lambda \notin \mathfrak{F}$ , then  $-\widehat{\Delta}_m f|_{V_m} = R(\lambda)f|_{V_m}$ .*
- (2) *Conversely, if  $-\widehat{\Delta}_m f = R(\lambda)f$ , and  $\lambda \notin \mathfrak{F}$ , then there exists a unique extension  $\bar{f}$  of  $f$  such that  $-\widehat{\Delta}_{m+1}\bar{f} = \lambda\bar{f}$ .*

The (normalized) Laplacian  $\Delta$  on  $\mathbf{K}$  can be defined as a limit of the normalized discrete Laplacians  $\widehat{\Delta}_m$ .

**Definition 3** [Kigami 1993]. Let  $\rho = 1/(K_D(0)r_0)$ , called the *Laplacian renormalization constant*, and let

$$\mathcal{D} = \left\{ u \in C(\mathbf{K}) : \text{there exists a function } f \in C(\mathbf{K}) \text{ and} \right. \\ \left. \lim_{m \rightarrow \infty} \rho^m \widehat{\Delta}_m u(x) = f(x) \text{ uniformly for } x \in V_* \setminus V_0 \right\}.$$

The (normalized) Laplacian on the fractal  $\mathbf{K}$ ,  $\Delta$ , is defined by  $\Delta u = f$ , where  $f$  is the function appearing above.

In some cases, spectra of Laplacians can be obtained through an iterative process called spectral decimation.

**Definition 4.** For a p.c.f. self-similar set  $\mathbf{K}$ , we say that the Laplacian,  $-\Delta$ , with Dirichlet boundary conditions, admits *spectral decimation with spectral decimation function*  $R$  if all eigenvalues of  $-\Delta$  are of the form

$$\rho^i \lim_{m \rightarrow \infty} \rho^m \phi_v(x), \quad x \in \mathfrak{F}_{i+1} \quad \text{and} \quad i \in \mathbb{N} \cup \{0\},$$

where  $v = v_m \cdots v_1$  with

$$v_j \in \{0, \dots, \#(\text{branches of the inverse function of } R) - 1\},$$

and  $\phi_v = \phi_{v_m} \cdots \phi_{v_1}$  with  $\phi_k$  being the  $(k + 1)$ -th branch of the inverse functions of  $R$ ; that is, the  $\phi_j$  are ordered according to their domains, so that if  $x$  is in the domain of  $\phi_j$  and  $y$  in the domain of  $\phi_{j+1}$ , then  $x \leq y$ . In particular,  $\phi_0$  is the first branch of the inverses.

In the case when  $\phi_0(z) < z$  for all positive  $z$  on its domain, Shima [1996] has shown that after a finite number of steps, only the bottom branch of the inverse functions,  $\phi_0$ , can be applied. Therefore, all eigenvalues of  $-\Delta$  must be of the form

$$(2-5) \quad \rho^i \lim_{m \rightarrow \infty} \rho^m \phi_0^{(m-j)} \phi_{v'}(z),$$

where  $z \in \mathfrak{F}_{i+1}$ ,  $|v'| = j$ , and  $i \in \mathbb{N} \cup \{0\}$ .

### 3. Spectral decimation function for $\mathcal{V}\mathcal{S}_n$

We begin by recalling the definition of the Vicsek set,  $\mathcal{V}\mathcal{S}$ . It is a p.c.f. self-similar set, which is constructed from the 1/3-similitudes,  $F_1, \dots, F_5 : \mathbb{R}^2 \rightarrow \mathbb{R}^2$  with

$$F_1(x) = \frac{x}{3}, \quad F_2(x) = \frac{x}{3} + \frac{2}{3}(1, 0), \quad F_3(x) = \frac{x}{3} + \frac{2}{3}(1, 1), \\ F_4(x) = \frac{x}{3} + \frac{2}{3}(0, 1), \quad F_5(x) = \frac{x}{3} + \frac{2}{3}(1/2, 1/2).$$

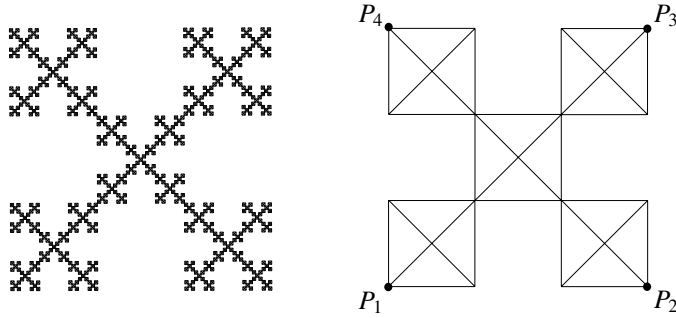

**Figure 1.** The Vicsek set  $\mathcal{V}\mathcal{S}_2$ .

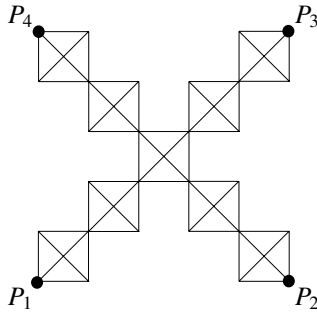

**Figure 2.** First step graph of the Vicsek set  $\mathcal{V}\mathcal{S}_3$ .

The Vicsek set  $\mathcal{V}\mathcal{S}$  is the unique compact set satisfying

$$\mathcal{V}\mathcal{S} = \bigcup_{s=1}^5 F_s(\mathcal{V}\mathcal{S}),$$

with boundary points  $V_0 = \{p_1 = (0, 0), p_2 = (1, 0), p_3 = (1, 1), p_4 = (0, 1)\}$ . It is an example of a postcritically finite fractal (see Example 5.15 in [Barlow 1998]). The set of  $m$  step vertices,  $V_m$ , is defined as  $\bigcup_{w \in W_m} F_w(V_0)$  for all  $m \in \mathbb{N}$ . Each  $V_m$  is a subset of  $\mathcal{V}\mathcal{S}$  and  $V_* := \bigcup_{m=1}^\infty V_m$  is dense in  $\mathcal{V}\mathcal{S}$ , so we can use the sequence  $(V_m)_{m \in \mathbb{N}}$  as a set of increasingly refined “grids” to approximate  $\mathcal{V}\mathcal{S}$ . The fractal and the first step graph are shown in Figure 1.

We now define the  $n$ -branch Vicsek set,  $\mathcal{V}\mathcal{S}_n$ , with the same four boundary points  $p_1, p_2, p_3$ , and  $p_4$ , but with  $n$  squares in each of the four directions. See Figure 2 for the first step graph of  $\mathcal{V}\mathcal{S}_3$ .

With this notation,  $\mathcal{V}\mathcal{S} = \mathcal{V}\mathcal{S}_2$ . Let  $N = 4n - 3$  and  $\lambda = 1/(2n - 1)$ . We have  $N$   $\lambda$ -similitudes  $F_1, \dots, F_N : \mathbb{R}^2 \rightarrow \mathbb{R}^2$ . We define  $V_0, V_m = V_m(n)$ , and  $V_* = V_*(n)$  as in the Vicsek set with 5 replaced by  $N$ . In particular, we let

$$V_1 \setminus V_0 = \{q_1, q_2, \dots, q_{12(n-1)}\}$$



denote the set of vertices in  $V_1 \setminus V_0$ . The  $n$ -branch Vicsek set  $\mathcal{V}\mathcal{S}_n$  is the unique compact fixed point of  $\bigcup_{s=1}^N F_s$ . It is also a p.c.f. self-similar fractal (see [Malozemov and Teplyaev 2003]) with Hausdorff dimension  $\log N / \log \lambda$ .

In this section we will derive a formula for the spectral decimation function for the standard Laplacian with Dirichlet boundary condition on the  $n$ -branch Vicsek set  $\mathcal{V}\mathcal{S}_n$ . To be precise, we will prove the following theorem.

**Theorem 5.** *Define*

$$(3-1) \quad f_n(\lambda) := T_n(3\lambda - 1) - 3T_{n-1}(3\lambda - 1),$$

$$(3-2) \quad g_n(\lambda) := U_{n-1}(3\lambda - 1) - U_{n-2}(3\lambda - 1),$$

$$(3-3) \quad h_n(\lambda) := U_{n-1}(3\lambda - 1) - 3U_{n-2}(3\lambda - 1),$$

$$(3-4) \quad l_n(\lambda) := U_{n-1}(3\lambda - 1) + U_{n-2}(3\lambda - 1),$$

where  $T_n$  and  $U_n$  are Chebyshev polynomials of the first and the second kind defined by the same recurrence relation

$$(3-5) \quad P_{n+1}(x) = 2xP_n(x) - P_{n-1}(x),$$

with initial conditions  $T_0(x) = 1$ ,  $T_1(x) = x$  and  $U_0(x) = 1$ ,  $U_1(x) = 2x$ . Then the spectral decimation function  $R$  is

$$(3-6) \quad R(\lambda) = \frac{\lambda - K_T(\lambda)}{K_D(\lambda)} = \lambda g_n(\lambda) h_n(\lambda)$$

and  $R$  satisfies

$$(3-7) \quad 3R(\lambda) - 4 = f_n(\lambda)l_n(\lambda).$$

Moreover, the forbidden eigenvalues are  $4/3$ , and zeros of  $f_n$  and  $g_n$ .

The proof of this theorem will require a number of preliminary results.

We use  $D$  to denote the Laplacian matrix on the complete graph  $G_0 = (V_0, E_0)$  and let  $H_1$  be the matrices representing the standard graph Laplacians on  $V_1 = V_1(n)$ . Hence

$$D = \begin{pmatrix} -3 & 1 & 1 & 1 \\ 1 & -3 & 1 & 1 \\ 1 & 1 & -3 & 1 \\ 1 & 1 & 1 & -3 \end{pmatrix}.$$

We decompose  $H_1$  as usual:

$$H_1 = \begin{pmatrix} T & J^t \\ J & X \end{pmatrix},$$

where  $T$  is a diagonal matrix with

$$T_{i,i} = -(\text{the number of neighboring points of } p_i)$$

and  $J$  is the incidence matrix of  $V_0$  and  $V_1 \setminus V_0$ . That is, if  $q_i$  is a neighboring point of  $p_j$ , then  $J_{i,j} = 1$ , otherwise  $J_{i,j} = 0$ . Hence there are 3 entries equal to 1 on each column of  $J$  and the rest are 0. The matrix  $X$  is a square matrix with  $X_{i,i} = -(\text{the number of neighboring points of } q_i)$ . Moreover, if  $q_i$  is a neighboring point of  $q_j$ , then  $X_{i,j} = 1$ ; otherwise,  $X_{i,j} = 0$ . Define  $M$  to be the diagonal matrix with  $M_{i,i} = -X_{i,i}$ .

It is easy to see that all diagonal entries of  $T - J^t(X + \lambda M)J$  are identical and all the off-diagonal entries are the same. Consequently, the standard Laplacian on the  $n$ -branch Vicsek set has a strong harmonic structure and so it admits spectral decimation.

**Notation.** For any set  $V$ , we continue to denote all linear functions on  $V$  as  $\ell(V)$  and all linear functions on  $V$  with zero boundary conditions  $\ell_0(V)$ . In the case of  $\mathcal{V}\mathcal{G}_n$ , the values of  $u \in \ell_0(V_1)$  on the  $j$ -th branch of  $\mathcal{V}\mathcal{G}_n$  (where  $j = 1, 2, 3$  or  $4$ ) are written as

$$\begin{aligned} u(x_i, j) &:= u_{i,j}, \\ u(y'_i, j) &:= u'_{i,j}, \\ u(y''_i, j) &:= u''_{i,j}, \end{aligned}$$

where  $u(x_i, j)$  is the function value of  $u$  on the  $i$ -th vertex on the diagonal (counting from the outside to the inside) of the  $j$ -th branch ( $1 \leq i \leq n$ ),  $u(y'_i, j)$  is the value of  $u$  on the  $i$ -th vertex below the diagonal of the  $j$ -th branch ( $1 \leq i \leq n - 1$ ), and  $u(y''_i, j)$  is the value of  $u$  on the  $i$ -th vertex above the diagonal of the  $j$ -th branch ( $1 \leq i \leq n - 1$ ). See Figure 3 for more details.

Recall that the normalized discrete Laplacian  $\widehat{\Delta}_m$  on the  $m$ -step graph is defined as

$$\widehat{\Delta}_m u(x) = \frac{1}{\text{deg } x} \sum_{y \sim_m x} (u(y) - u(x)),$$

for  $u \in \ell(V_m \setminus V_0)$ . Therefore, the Dirichlet eigenvalue problem  $\widehat{\Delta}_1 u = -\lambda u$  (that is,  $(X + \lambda M)u = 0$ ) is given explicitly by the following system:

$$(3-8) \quad \begin{cases} u_{1,j} = 0, \\ u_{i,j} + (3\lambda - 3)u'_{i,j} + u''_{i,j} + u_{i+1,j} = 0, \\ u_{i,j} + u'_{i,j} + (3\lambda - 3)u''_{i,j} + u_{i+1,j} = 0, \\ u_{i-1,j} + u'_{i-1,j} + u''_{i-1,j} + (6\lambda - 6)u_{i,j} + u'_{i,j} + u''_{i,j} + u_{i+1,j} = 0, \\ u_{n-1,j} + u'_{n-1,j} + u''_{n-1,j} + (6\lambda - 6)u_{n,j} + \sum_{k=1, k \neq j}^4 u_{n,k} = 0, \end{cases}$$

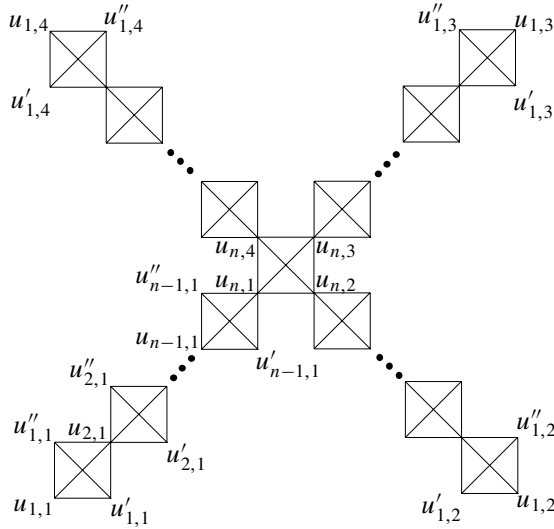

**Figure 3.** A function  $u$  defined on the first step graph of  $\mathcal{V}^n$ .

where  $1 \leq j \leq 4$ , the second and the third equations hold for  $1 \leq i \leq n - 1$ , and the fourth equation holds for  $2 \leq i \leq n - 1$ .

We introduce new variables

$$u_{i,j}^+ := \frac{u'_{i,j} + u''_{i,j}}{2}, \quad u_{i,j}^- := \frac{u'_{i,j} - u''_{i,j}}{2}$$

to find the equivalent system

$$(3-9) \quad \begin{cases} u_{1,j} = 0, \\ (3\lambda - 4)u_{i,j}^- = 0, & 1 \leq i \leq n - 1, \\ u_{i,j} + (3\lambda - 2)u_{i,j}^+ + u_{i+1,j} = 0, & 1 \leq i \leq n - 1, \\ (3\lambda - 4)(u_{i-1,j}^+ - 2u_{i,j} + u_{i,j}^+) = 0, & 2 \leq i \leq n - 1, \\ (3\lambda - 4)(-u_{n-1,j}^+ + 2u_{n,j}) + \sum_{k=1}^4 u_{n,k} = 0, \end{cases}$$

where  $1 \leq j \leq 4$ .

If we assume  $\lambda \neq 4/3$ , then  $u_{i,j}^- = 0$ , or equivalently,  $u'_{i,j} = u''_{i,j}$ , ( $= u_{i,j}^+$ ), so the first four equations are equivalent to the following system:

$$(3-10) \quad \begin{cases} u_{1,j} = 0, \\ u_{i,j}^- = 0, \\ u_{i,j} + (3\lambda - 2)u_{i,j}^+ + u_{i+1,j} = 0, & 1 \leq i \leq n - 1, \\ u_{i-1,j}^+ - 2u_{i,j} + u_{i,j}^+ = 0. \end{cases}$$

If we fix  $j$  and write out the system, we will see that all occurring variables can eventually be expressed as a product of some polynomial in  $\lambda$  and  $u_{1,j}^+$ . Hence we may write

$$(3-11) \quad \begin{cases} u_{i,j} := (-1)^{i-1} p_{i-1}(\lambda) \cdot u_{1,j}^+, & 1 \leq i \leq n, \\ u_{i,j}^+ := (-1)^{i-1} q_{i-1}(\lambda) \cdot u_{1,j}^+, & 1 \leq i \leq n-1, \end{cases}$$

for some polynomials  $p_i$  and  $q_i$ , which do not depend on  $j$ . From (3-10), we see that  $p_i$  and  $q_i$  satisfy the linear recurrence relations

$$(3-12) \quad \begin{cases} p_i(\lambda) = p_{i-1}(\lambda) + (3\lambda - 2)q_{i-1}(\lambda), \\ q_i(\lambda) = 2p_i(\lambda) + q_{i-1}(\lambda), \end{cases}$$

with initial conditions  $p_0 = 0$ ,  $q_0 = 1$ . A straightforward induction shows:

**Lemma 6.** *The polynomials  $p_i$  and  $q_i$  have the expressions*

$$\begin{cases} p_i(\lambda) = (3\lambda - 2)U_{i-1}(3\lambda - 1), \\ q_i(\lambda) = U_i(3\lambda - 1) - U_{i-1}(3\lambda - 1). \end{cases}$$

Put (3-11) into (3-9) to get

$$(3\lambda - 4)(2p_{n-1}(\lambda) + q_{n-2}(\lambda))u_{1,j}^+ + p_{n-1}(\lambda) \sum_{k=1}^4 u_{1,k}^+ = 0.$$

By our recurrence relation (3-12), we have the four equations

$$(3-13) \quad (3\lambda - 4)q_{n-1}(\lambda)u_{1,j}^+ + p_{n-1}(\lambda) \sum_{k=1}^4 u_{1,k}^+ = 0, \quad (1 \leq j \leq 4).$$

Letting

$$\begin{aligned} g_n(\lambda) &:= q_{n-1} = U_{n-1}(3\lambda - 1) - U_{n-2}(3\lambda - 1), \\ f_n(\lambda) &:= (3\lambda - 4)q_{n-1}(\lambda) + 4p_{n-1}(\lambda) = T_n(3\lambda - 1) - 3T_{n-1}(3\lambda - 1), \end{aligned}$$

we see that those equations are equivalent to

$$(3-14) \quad \begin{cases} g_n(\lambda)(u_{1,1}^+ - u_{1,2}^+) = 0, \\ g_n(\lambda)(u_{1,1}^+ - u_{1,3}^+) = 0, \\ g_n(\lambda)(u_{1,1}^+ - u_{1,4}^+) = 0, \\ f_n(\lambda)(\sum_{k=1}^4 u_{1,k}^+) = 0. \end{cases}$$

Equation (3-10) implies

$$u = 0 \text{ if and only if } u_{1,1}^+ = u_{1,2}^+ = u_{1,3}^+ = u_{1,4}^+ = 0.$$

Therefore, if  $\lambda \neq 4/3$  is an eigenvalue, then  $f_n(\lambda) = 0$  or  $g_n(\lambda) = 0$  by (3-14). It follows that

$$(3-15) \quad \det(X + \lambda M) = cf_n(\lambda)g_n^3(\lambda)(3\lambda - 4)^{8n-9},$$

for some nonzero constant  $c$ .

Next we shall solve  $(X + \lambda M)u = v$  by choosing a special  $v$ . Let  $u \in \ell(V_1 \setminus V_0)$ . We perform a kind of “averaging” through the four branches by introducing another change of coordinates:

$$\begin{cases} s_{i,1} = u_{i,1} + u_{i,2} + u_{i,3} + u_{i,4}, \\ s_{i,2} = u_{i,1} - u_{i,2}, \\ s_{i,3} = u_{i,1} - u_{i,3}, \\ s_{i,4} = u_{i,1} - u_{i,4}. \end{cases}$$

We can also do the same operations for  $s_{i,j}^+$ . Then the inverse coordinate change is

$$\begin{cases} u_{i,1} = 1/4(s_{i,1} + s_{i,2} + s_{i,3} + s_{i,4}), \\ u_{i,2} = 1/4(s_{i,1} - 3s_{i,2} + s_{i,3} + s_{i,4}), \\ u_{i,3} = 1/4(s_{i,1} + s_{i,2} - 3s_{i,3} + s_{i,4}), \\ u_{i,4} = 1/4(s_{i,1} + s_{i,2} + s_{i,3} - 3s_{i,4}), \end{cases}$$

and similarly for  $u_{i,j}^+$  ( $1 \leq j \leq 4$ ). For any function  $v \in \ell(V_1 \setminus V_0)$ , we can write

$$\begin{aligned} j = 1: & \quad t_{i,1} = v_{i,1} + v_{i,2} + v_{i,3} + v_{i,4}, & t_{i,1}^+ &= v_{i,1}^+ + v_{i,2}^+ + v_{i,3}^+ + v_{i,4}^+, \\ j = 2, 3, 4: & \quad t_{i,j} = v_{i,1} - v_{i,j}, & t_{i,j}^+ &= v_{i,1}^+ - v_{i,j}^+. \end{aligned}$$

We shall choose a special  $v$ ,  $t_{i,j}$  and  $t_{i,j}^+$  will then be the new changed variables. For example, if  $v = v^{(1)}$  is the function on  $V_1 \setminus V_0$  corresponding to the first column of  $J$ , that is,  $v'_{1,1} = v''_{1,1} = v_{2,1} = 1$  and the remaining entries are 0, then for all  $1 \leq j \leq 4$ ,  $t_{1,j} = 0$ ,  $t_{1,j}^+ = 1$ ,  $t_{2,j} = 1$ ,  $t_{i,j}^+ = 0$  ( $i \geq 2$ ),  $t_{i,j} = 0$  ( $i > 2$ ), and  $v_{i,j}^- = 0$  ( $1 \leq i \leq n-1$ ). See Figure 4 for the function corresponding to  $v^{(1)}$ .

Next we shall solve the equation  $(X + \lambda M)u = v$  for  $v = v^{(1)}$  and  $u \in \ell(V_1 \setminus V_0)$ , which is equivalent to the system

$$\begin{cases} u_{i,j} + (3\lambda - 2)u_{i,j}^+ + u_{i+1,j} = v_{i,j}^+, & 1 \leq i \leq n-1, \\ u_{i-1,j} + 2u_{i-1,j}^+ + (6\lambda - 6)u_{i,j} + 2u_{i,j}^+ + u_{i+1,j} = v_{i,j}, & 2 \leq i \leq n-1, \\ u_{n-1,j} + 2u_{n-1,j}^+ + (6\lambda - 7)u_{n,j} + \sum_{k=1}^4 u_{n,k} = v_{n,j}, \\ (3\lambda - 4)u_{i,j}^- = v_{i,j}^-, & 1 \leq i \leq n-1. \end{cases}$$

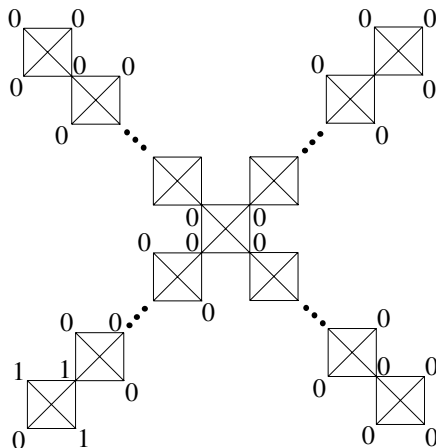

Figure 4. A function  $v$  defined on the first step graph of  $\mathcal{V}^L_n$ .

By summing together all four equations when  $j = 1$  and subtracting two equations when  $j \neq 1$ , and the change of coordinates, we see that it is also equivalent to

$$\begin{cases} s_{i,j} + (3\lambda - 2)s_{i,j}^+ + s_{i+1,j} = t_{i,j}^+, & 1 \leq i \leq n - 1, \\ s_{i-1,j} + 2s_{i-1,j}^+ + (6\lambda - 6)s_{i,j} + 2s_{i,j}^+ + s_{i+1,j} = t_{i,j}, & 2 \leq i \leq n - 1, \\ s_{n-1,j} + 2s_{n-1,j}^+ + (6\lambda - 7 + 4\delta_{1,j})s_{n,j} = t_{n,j}, \\ (3\lambda - 4)u_{i,j}^- = v_{i,j}^-, & 1 \leq i \leq n - 1. \end{cases}$$

Under the new system of coordinates, the matrix  $A$  representing  $X + \lambda M$  is the direct sum of the five blocks

$$A_0 = \begin{bmatrix} 3\lambda - 4 & & & & \\ & 3\lambda - 4 & & & \\ & & \ddots & & \\ & & & 3\lambda - 4 & \\ & & & & 3\lambda - 4 \end{bmatrix}_{4(n-1) \times 4(n-1)}$$

which is a diagonal matrix of size  $4(n - 1) \times 4(n - 1)$  corresponding to the last equation in the above system, and for  $j = 1, 2, 3,$  and  $4,$

$$A_j = \begin{bmatrix} 3\lambda - 2 & 1 & 0 & 0 & 0 & 0 & 0 & 0 & 0 & 0 \\ 2 & 6\lambda - 6 & 2 & 1 & 0 & 0 & 0 & 0 & 0 & 0 \\ 0 & 1 & 3\lambda - 2 & 1 & 0 & 0 & 0 & 0 & 0 & 0 \\ 0 & 1 & 2 & 6\lambda - 6 & 2 & 1 & 0 & 0 & 0 & 0 \\ & & & & & & \ddots & \ddots & \ddots & \\ 0 & 0 & 0 & 0 & 0 & \cdots & 0 & 1 & 3\lambda - 2 & 1 \\ 0 & 0 & 0 & 0 & 0 & \cdots & 0 & 1 & 2 & 6\lambda - 7 + 4\delta_{1,j} \end{bmatrix}.$$

Blocks of the augmented matrix for the equation  $(X + \lambda M)u = v$  when  $j = 2, 3$  and 4 are

$$[A_j|v] = \left[ \begin{array}{cccccccccc|c} 3\lambda - 2 & 1 & 0 & 0 & 0 & 0 & 0 & 0 & 0 & 0 & t_{1,j}^+ \\ 2 & 6\lambda - 6 & 2 & 1 & 0 & 0 & 0 & 0 & 0 & 0 & t_{2,j} \\ 0 & 1 & 3\lambda - 2 & 1 & 0 & 0 & 0 & 0 & 0 & 0 & t_{2,j}^+ \\ 0 & 1 & 2 & 6\lambda - 6 & 2 & 1 & 0 & 0 & 0 & 0 & t_{3,j} \\ & & & & & \ddots & \ddots & \ddots & & & \\ 0 & 0 & 0 & 0 & 0 & \cdots & 0 & 1 & 3\lambda - 2 & 1 & t_{n-1,j}^+ \\ 0 & 0 & 0 & 0 & 0 & \cdots & 0 & 1 & 2 & 6\lambda - 7 + 4\delta_{1,j} & t_{n,j} \end{array} \right],$$

which can be row-reduced into the form

$$\left[ \begin{array}{cccccccccc|c} 3\lambda - 2 & 1 & 0 & \cdots & 0 & 0 & 0 & 0 & 0 & 0 & t_{1,j}^+ \\ 3\lambda - 4 - 2(3\lambda - 4) & 3\lambda - 4 & \cdots & 0 & 0 & 0 & 0 & 0 & 0 & 0 & t_{1,j}^+ - t_{2,j} + t_{2,j}^+ \\ 0 & 1 & 3\lambda - 2 & \cdots & 0 & 0 & 0 & 0 & 0 & 0 & t_{2,j}^+ \\ 0 & 0 & 3\lambda - 4 & \cdots & 0 & 0 & 0 & 0 & 0 & 0 & t_{2,j}^+ - t_{3,j} + t_{3,j}^+ \\ & & & \ddots & \ddots & & & & & & \vdots \\ 0 & 0 & 0 & \cdots & 1 & 3\lambda - 2 & 1 & 0 & 0 & 0 & t_{n-1,j}^+ \\ 0 & 0 & 0 & \cdots & 0 & 3\lambda - 4 - 2(3\lambda - 4) - 4\delta_{1,j} & -4\delta_{1,j} & 0 & 0 & 0 & t_{n-1,j}^+ - t_{n,j} \end{array} \right],$$

and

$$[A_0|v] = \left[ \begin{array}{cccc|c} 3\lambda - 4 & & & & v_{1,j}^- \\ & 3\lambda - 4 & & & v_{2,j}^- \\ & & \ddots & & \vdots \\ & & & 3\lambda - 4 & v_{n-1,j}^- \end{array} \right].$$

In the special case when  $v$  is the function corresponding to the first column of  $J$ , our linear system becomes

$$\left[ \begin{array}{cccccccccc|c} 3\lambda - 2 & 1 & 0 & \cdots & 0 & 0 & 0 & 0 & 0 & 0 & s_{1,j}^+ \\ 3\lambda - 4 - 2(3\lambda - 4) & 3\lambda - 4 & \cdots & 0 & 0 & 0 & 0 & 0 & 0 & 0 & s_{2,j} \\ 0 & 1 & 3\lambda - 2 & \cdots & 0 & 0 & 0 & 0 & 0 & 0 & s_{2,j}^+ \\ 0 & 0 & 3\lambda - 4 & \cdots & 0 & 0 & 0 & 0 & 0 & 0 & s_{3,j} \\ & & & \ddots & \ddots & & & & & & \vdots \\ 0 & 0 & 0 & \cdots & 1 & 3\lambda - 2 & 1 & 0 & 0 & 0 & s_{n-1,j}^+ \\ 0 & 0 & 0 & \cdots & 0 & 3\lambda - 4 - 2(3\lambda - 4) - 4\delta_{1,j} & -4\delta_{1,j} & 0 & 0 & 0 & s_{n,j} \end{array} \right] = \begin{bmatrix} 1 \\ 0 \\ 0 \\ 0 \\ \vdots \\ 0 \\ 0 \end{bmatrix}$$

and

$$\begin{bmatrix} 3\lambda - 4 & & & & \\ & 3\lambda - 4 & & & \\ & & \ddots & & \\ & & & \ddots & \\ & & & & 3\lambda - 4 \end{bmatrix} \begin{bmatrix} u_{1,j}^- \\ u_{2,j}^- \\ \vdots \\ u_{n-1,j}^- \end{bmatrix} = \begin{bmatrix} 0 \\ 0 \\ 0 \\ 0 \end{bmatrix},$$

which implies that when  $\lambda \neq 4/3$ ,  $u_{i,j}^- = 0$  for all  $i, j$ . By clearing all unnecessary factors  $3\lambda - 4$ , whenever possible, we have the system

$$(3-16) \quad \begin{cases} (3\lambda - 2)s_{1,j}^+ + s_{2,j} = 1, \\ s_{1,j}^+ - 2s_{2,j} + s_{2,j}^+ = 0, \\ s_{2,j} + (3\lambda - 2)s_{2,j}^+ + s_{3,j} = 0, \\ \vdots \\ s_{n-1,j} + (3\lambda - 2)s_{n-1,j}^+ + s_{n,j} = 0, \\ (3\lambda - 4)s_{n-1,j}^+ - (2(3\lambda - 4) + 4\delta_{1,j})s_{n,j} = 0. \end{cases}$$

The first  $2n - 3$  equations allow us to write all unknowns  $s_{i,j}$  and  $s_{i,j}^+$  ( $i > 1$  and  $1 \leq j \leq 4$ ) in terms of  $s_{1,j}^+$  as

$$\begin{aligned} s_{i,j}^+ &= (-1)^{i-1} (a_i(\lambda)s_{1,j}^+ + b_i(\lambda)), \\ s_{i,j} &= (-1)^{i-1} (c_i(\lambda)s_{1,j}^+ + d_i(\lambda)), \end{aligned}$$

for some polynomials  $a_i, b_i, c_i$  and  $d_i$ .

**Lemma 7.** *If  $(X + \lambda M)u = v^{(1)}$  and  $s_{i,j}$  and  $s_{i,j}^+$  are defined as above, then for  $i > 1$  and  $1 \leq j \leq 4$ ,*

$$(3-17) \quad s_{i,j}^+ = (-1)^{i-1} ((U_{i-1}(y) - U_{i-2}(y))s_{1,j}^+ - 2U_{i-2}(y)),$$

$$(3-18) \quad s_{i,j} = (-1)^{i-1} ((y - 1)U_{i-2}(y)s_{1,j}^+ - (U_{i-2}(y) - U_{i-3}(y))),$$

where  $y = 3\lambda - 1$ . For  $i = 1$ , we have

$$(3-19) \quad s_{1,1}^+ = \frac{(2y - 2)U_{n-2}(y) - 4U_{n-3}(y)}{(2y^2 - 3y - 1)U_{n-2}(y) - (y - 3)U_{n-3}(y)},$$

$$(3-20) \quad s_{1,j}^+ = \frac{2U_{n-2}}{U_{n-1} - U_{n-2}} \quad (2 \leq j \leq 4).$$

*Proof.* We rewrite the first equation in (3-16) as

$$(-1) + (3\lambda - 2)s_{1,j}^+ + s_{2,j} = 0$$

and we use the fictitious unknown  $\hat{s}_{1,j} = -1$ , to achieve a more symmetric equation

$$\hat{s}_{1,j} + (3\lambda - 2)s_{1,j}^+ + s_{2,j} = 0.$$



This, together with the other equations

$$\begin{cases} s_{i,j} + (3\lambda - 2)s_{i,j}^+ + s_{i+1,j} = 0, \\ s_{i,j}^+ - 2s_{i+1,j} + s_{i+1,j}^+ = 0, \end{cases}$$

imply that  $a_i, b_i, c_i,$  and  $d_i$  satisfy the recurrence relations

$$(3-21) \quad \begin{cases} a_{i+1} = (6\lambda - 3)a_i + 2c_i, \\ b_{i+1} = (6\lambda - 3)b_i + 2d_i, \\ c_{i+1} = (3\lambda - 2)a_i + c_i, \\ d_{i+1} = (3\lambda - 2)b_i + d_i, \end{cases}$$

with initial conditions  $a_1 = 1, b_1 = 0, c_1 = 0, d_1 = -1$ . In terms of the matrices,

$$A = \begin{bmatrix} 6\lambda - 3 & 2 \\ 3\lambda - 2 & 1 \end{bmatrix} = \begin{bmatrix} 2y - 1 & 2 \\ y - 1 & 1 \end{bmatrix},$$

$$X_i = \begin{bmatrix} a_i & b_i \\ c_i & d_i \end{bmatrix}.$$

Hence (3-21) can be written as  $X_{i+1} = AX_i$  with

$$X_1 = \begin{bmatrix} 1 & 0 \\ 0 & -1 \end{bmatrix}.$$

Then the unique solution to (3-21) is clearly given by  $X_i = A^{i-1}X_1$ . Hence our proof will be finished once we have proved that

$$A^k = \begin{bmatrix} U_k(y) - U_{k-1}(y) & 2U_{k-1}(y) \\ (y - 1)U_{k-1}(y) & U_{k-1}(y) - U_{k-2}(y) \end{bmatrix}.$$

To prove this, we use induction on  $k \geq 1$ . When  $k = 1$ , note that  $U_0 = 1$  and  $U_1 = 2y$ , so recursive formulas for Chebyshev polynomials give us  $U_{-1} = 0$ . Hence

$$\begin{bmatrix} U_1 - U_0 & 2U_0 \\ (y - 1)U_0 & U_0 - U_{-1} \end{bmatrix} = \begin{bmatrix} 2y - 1 & 2 \\ y - 1 & 1 \end{bmatrix} = A.$$

Next we assume that our claim is true for  $k$ . Hence by the induction assumption, we have

$$\begin{aligned} A^{k+1} &= \begin{bmatrix} 2y - 1 & 2 \\ y - 1 & 1 \end{bmatrix} \begin{bmatrix} U_k - U_{k-1} & 2U_{k-1} \\ (y - 1)U_{k-1} & U_{k-1} - U_{k-2} \end{bmatrix} \\ &= \begin{bmatrix} (2yU_k - U_{k-1}) - U_k & 2(2yU_{k-1} - U_{k-2}) \\ (y - 1)U_k & (2yU_{k-1} - U_{k-2}) - U_{k-1} \end{bmatrix} \\ &= \begin{bmatrix} U_{k+1} - U_k & 2U_k \\ (y - 1)U_k & U_k - U_{k-1} \end{bmatrix}. \end{aligned}$$

Here we have used the recursive identity  $U_{k+1} = 2yU_k - U_{k-1}$  for Chebyshev polynomials in the last equality. Hence the claim is proved.

Having expressed all our unknowns in terms of the single variable  $s_{1,j}^+$ , we can solve for  $s_{1,j}^+$  by making use of the very last equation:

$$(3\lambda - 4)s_{n-1,j}^+ - (2(3\lambda - 4) + 4\delta_{1,j})s_{n,j} = 0.$$

We first solve for  $s_{1,j}^+$  when  $j = 2, 3, 4$ . Since  $\delta_{1,j} = 0$ , the above equation simplifies to  $s_{n-1,j}^+ = 2s_{n,j}$ . Substituting the expressions for  $s_{n-1,j}^+$  and  $s_{n,j}$  from (3-17) and (3-18), and using the identity  $U_{k+1} = 2yU_k - U_{k-1}$ , we have that for  $j = 2, 3$ , and 4,

$$s_{1,j}^+ = \frac{2U_{n-2}}{U_{n-1} - U_{n-2}}.$$

Next we solve for  $s_{1,1}^+$ , starting from the equations  $(6\lambda - 4)s_{n,1} - (3\lambda - 4)s_{n-1,1}^+ = 0$  or  $(2y - 2)s_{n,1} - (y - 3)s_{n-1,1}^+ = 0$  as  $y = 3\lambda - 1$ . Again, using what we have shown in the first part of the lemma, we find that

$$s_{1,1}^+ = \frac{(2y - 2)U_{n-2} - 4U_{n-3}}{(2y^2 - 3y - 1)U_{n-2} - (y - 3)U_{n-3}}.$$

Moreover, we can further simplify the denominator by the identity  $T_n = yU_{n-1} - U_{n-2}$  so that

$$s_{1,1}^+ = \frac{(2y - 2)U_{n-2} - 4U_{n-3}}{T_n - 3T_{n-1}} = \frac{2(T_{n-1} - U_{n-2} - U_{n-3})}{T_n - 3T_{n-1}}. \quad \square$$

Before we compute  $K_D$  and  $\lambda - K_T$ , we derive some formulas for future use, which can be obtained by the recursive formulas for Chebyshev polynomials and the formula

$$(3-22) \quad T_n = yU_{n-1} - U_{n-2}.$$

**Lemma 8.**

$$(3-23) \quad 1 + s_{1,1}^+ = (y + 1) \frac{U_{n-1}(y) - 3U_{n-2}(y)}{T_n(y) - 3T_{n-1}(y)}.$$

$$(3-24) \quad \left| \begin{array}{cc} T_{n-1} - U_{n-2} - U_{n-3} & U_{n-2} \\ T_n - 3T_{n-1} & U_{n-1} - U_{n-2} \end{array} \right| = 2, \text{ for any } n \geq 1.$$

$$(3-25) \quad s_{1,1}^+ - s_{1,2}^+ = \frac{4}{f_n(\lambda)g_n(\lambda)}.$$

Now we are ready to prove Theorem 5 about the expressions of the spectral decimation function  $R(\lambda)$  and  $3R(\lambda) - 4$  at the beginning of this section.

*Proof of Theorem 5.* First, note that

$$\begin{aligned} K_D &= (T - J^t(X + \lambda M)^{-1}J)_{2,1} \\ &= -\langle v^{(2)}, u \rangle, \end{aligned}$$

where  $v^{(j)}$  is the  $j$ -th column of  $J$  and  $u = (X + \lambda M)^{-1}v^{(1)}$ . By the definition of  $v^{(2)}$ , we know that

$$\begin{aligned} \langle v^{(2)}, u \rangle &= u'_{1,2} + u''_{1,2} + u_{2,2} \\ &= 2u^+_{1,2} + u_{2,2}, \\ &= 2[1/4(s_{1,1}^+ - s_{1,2}^+)] + \frac{1}{4}(s_{2,1} - s_{2,2}), \end{aligned}$$

where the last equality follows from the change of coordinates and a conclusion from Lemma 7 that the values of  $s_{1,j}$  and  $s_{1,j}^+$  do not depend on  $j$  for  $j = 2, 3$ , and 4. Hence (3-25) implies

$$\begin{aligned} K_D &= \frac{y-3}{4}(s_{1,1}^+ - s_{1,2}^+) \\ &= \frac{3\lambda - 4}{f_n(\lambda)g_n(\lambda)}. \end{aligned}$$

As for  $\lambda - K_T(\lambda)$ , note that the diagonal entries of  $D$  and  $T$  are  $-3$ , so

$$\begin{aligned} (3-26) \quad 3(\lambda - K_T(\lambda)) &= 3\lambda - 3 + 3K_D - \langle v^{(1)}, u \rangle \\ &= 3\lambda - 3 - 2(u^+_{1,1} + 3u^+_{1,2}) - (u_{2,1} + 3u_{2,2}). \end{aligned}$$

By our change of variables and using (3-23), we have

$$\begin{aligned} 3(\lambda - K_T) &= (3\lambda - 4) + (3\lambda - 4)s^+_{1,1} \\ &= (3\lambda - 4) \left( (y+1) \frac{U_{n-1}(y) - 3U_{n-2}(y)}{T_n(y) - 3T_{n-1}(y)} \right) \\ &= (3\lambda - 4) \cdot 3\lambda \cdot \frac{h_n(\lambda)}{f_n(\lambda)}. \end{aligned}$$

The definition of the spectral decimation function  $R$  gives

$$R(\lambda) = \frac{\lambda - K_T(\lambda)}{K_D(\lambda)} = \lambda \cdot g_n(\lambda) \cdot h_n(\lambda).$$

Lastly, we compute  $3R(\lambda) - 4$ . Equivalently, we show

$$3(\lambda - K_T(\lambda)) - 4K_D(\lambda) = (3\lambda - 4) \frac{l_n(\lambda)}{g_n(\lambda)}.$$

Together with our change of variables and Lemma 7, this holds by the equations

$$\begin{aligned} 3(\lambda - K_T(\lambda)) - 4K_D(\lambda) &= 3\lambda - 3 - K_D - \langle v^{(1)}, u \rangle \\ &= 3\lambda - 3 + \langle v^{(2)}, u \rangle - \langle v^{(1)}, u \rangle \\ &= 3\lambda - 3 + (2u_{1,2}^+ + u_{2,2}) - (2u_{1,1}^+ + u_{2,1}) \end{aligned}$$

By definition, the forbidden eigenvalues are the zeros of  $K_D$ , namely  $4/3$ , and the zeros of  $\det(X + \lambda M)$ , which are  $4/3$ , and the zeros of  $f_n$  and  $g_n$ . □

As eigenfunctions of  $-\widehat{\Delta}_1$  corresponding to different eigenvalues are orthogonal, we get an interesting corollary about properties of the Chebyshev polynomials.

**Corollary 9.** *Suppose  $\lambda$  and  $\mu$  are either different roots of  $f_n$  or different roots of  $g_n$ . Then*

$$\sum_{i=1}^{n-1} (p_i(\lambda)p_i(\mu) + q_{i-1}(\lambda)q_{i-1}(\mu)) = 0,$$

where  $p_i$  and  $q_i$  are defined in Lemma 6.

#### 4. Gaps in the spectrum of the Laplacian on $\mathcal{V}\mathcal{S}_n$

In this section, we shall prove that Theorem 13 of [Zhou 2008] applies to the infinite family of fractals  $\mathcal{V}\mathcal{S}_n$  and so there exist gaps in the spectrum of the standard Laplacian. Let  $\alpha_i$ ,  $\beta_i$ ,  $\zeta_i$  and  $\gamma_i$  be the roots of  $f_n$ ,  $g_n$ ,  $h_n$ , and  $l_n$  respectively. Then we can prove that they are alternating. More precisely, we have:

**Proposition 10.** *The function  $f_n$  has exactly  $n$  real roots  $\alpha_1, \alpha_2, \dots, \alpha_n$  and if we naturally order them, then  $\alpha_i$  and  $\beta_i$  are alternating and*

$$(4-1) \quad 0 < \alpha_1 < \beta_1 < \alpha_2 < \dots < \alpha_{n-1} < \beta_{n-1} < 2/3 < \alpha_n < 1.$$

Similarly, we have

$$(4-2) \quad 0 < \gamma_1 < \alpha_1 < \gamma_2 < \dots < \gamma_{n-1} < \alpha_{n-1} < 2/3 < \alpha_n < 1,$$

$$(4-3) \quad 0 < \beta_1 < \zeta_1 < \beta_2 < \dots < \zeta_{n-2} < \beta_{n-1} < 2/3 < \zeta_{n-1} < 1.$$

*Proof.* Equation (4-1) can be proved by noting  $f_n(0) = 4(-1)^n$ ,  $f_n(1) > 0$ ,  $f_n(2/3) = -2$  and that for  $1 \leq i \leq n - 2$ ,

$$\begin{aligned} f_n(\beta_{n-i}) &= \cos n \frac{(2i-1)\pi}{2n-1} - 3 \cos(n-1) \frac{(2i-1)\pi}{2n-1} \\ &= \begin{cases} 4 \sin \frac{(i-1/2)\pi}{2n-1}, & \text{if } i \text{ is even,} \\ -4 \sin \frac{(i-1/2)\pi}{2n-1}, & \text{if } i \text{ is odd.} \end{cases} \end{aligned}$$

Equations (4-2) and (4-3) can be proved in a similar fashion. □

**Proposition 11.** *There exist gaps in the spectrum of the standard Laplacian on the  $n$ -branch Viscek set  $\mathcal{V}\mathcal{S}_n$ .*

*Proof.* By Theorem 5 and Proposition 10, we can easily check that the following four conditions for the criterion for gaps [Zhou 2008, Theorem 13] are met:

- (1)  $R^{-1}([0, 4/3]) \subseteq [0, 4/3]$ ;
- (2)  $\phi_1(x)$  is defined and decreasing on  $[0, 4/3]$ ;
- (3)  $\phi_0(x)$  is strictly convex and  $\phi_0(4/3) < \phi_1(4/3)$ ;
- (4) there exists  $k_0$  such that for all  $k \geq k_0$  and all  $x \in \mathfrak{F}_k$ ,  $\phi_1(4/3) \leq x$ . □

Hambly and Kumagai [1999] have proved that the necessary heat kernel estimate holds for the standard Laplacian on  $\mathcal{V}\mathcal{S}_n$ . Hence we obtain the following immediate corollaries using the same argument by Strichartz [2005].

**Corollary 12.** *Let  $\{N_m\}$  be a sequence of integers such that  $\lambda_{N_m+1}/\lambda_{N_m} - 1$  is bounded away from zero. Then the partial sums of the Fourier series  $S_{N_m} f$  converge to  $f$  as  $m \rightarrow \infty$  in  $L^p$  for  $f \in L^p$  ( $1 \leq p < \infty$ ) and uniformly if  $f$  is continuous.*

**Corollary 13.** *Let  $1 < p < \infty$ . Let*

$$Sf(x) = \left( \sum_{m=1}^{\infty} |S_m f(x)|^2 \right)^{1/2},$$

for

$$S_m f(x) = \sum_{j=N_{m-1}+1}^{N_m} c_j u_j(x),$$

where  $u_j$  are either Dirichlet (or Neumann) eigenfunctions of the Laplacian and  $\{N_m\}$  is the same sequence as in the above theorem. Then there exist constants  $A_p$  and  $B_p$  such that

$$A_p \|f\|_p \leq \|Sf\|_p \leq B_p \|f\|_p.$$

### 5. Ordering the Dirichlet eigenvalues on $\mathcal{V}\mathcal{S}_n$

In this section, we prove the ordering of the Dirichlet eigenvalues in Theorems 17 and 19.

**5.1. Notation.** We shall fix  $n$  from now on and always write  $N = 2n - 2$ . Let  $R(\lambda)$  be the spectral decimation function, with its  $2n - 1$  inverses

$$\phi_0, \phi_1, \dots, \phi_N$$

listed in increasing order. Let

$$\rho = R'(0) = (2n - 1)(4n - 3)$$

be the Laplacian renormalization constant (recall that it is the product of the energy renormalization constant, which is  $K_D(0)^{-1} = 2n - 1$ , and the measure factor, which is  $4n - 3$ , the number of contraction maps for the standard Laplacian). Recall that the list of forbidden eigenvalues is

$$\mathfrak{F} = \{ \alpha_1 < \beta_1 < \alpha_2 < \beta_2 < \dots < \alpha_{n-1} < \beta_{n-1} < \alpha_n < 4/3 \},$$

where  $\alpha_i, \beta_j$  ( $i = 1, \dots, n, j = 1, \dots, n - 1$ ) are roots of  $f_n$  and  $g_n$  respectively.

Define the set of  $2n - 1$  symbols

$$\Sigma = \{0, 1, 2, \dots, N\},$$

and let  $W = \Sigma^*$  be the set of finite words on  $\Sigma$  (including the empty word). For any word  $w \in W$  of length  $j \geq 0$ , where  $w = w_j \dots w_1$  with  $w_1, \dots, w_j \in \Sigma$ , we set  $\phi_w = \phi_{w_j} \circ \dots \circ \phi_{w_1}$ . For  $\mu \in [0, 4/3]$ , we define

$$\lambda_w(\mu) = \lim_{m \rightarrow \infty} \rho^m \phi_0^{(m-j)} \circ \phi_w(\mu).$$

Then the spectral decimation tells us that the entire set of Dirichlet eigenvalues of  $-\Delta$  is a subset of

$$\Lambda^* = \{ \rho^k \lambda_w(\mu) : k \geq 0, w \in W, \mu \in \mathfrak{F} \}.$$

Clearly, for any word  $w$  we have  $\lambda_w = \lambda_{0\dots 0w}$ . Define an equivalence relation  $\sim$  on  $W$  as follows to reduce this redundancy:  $v \sim w$  if and only if there exists  $u \in W$  such that  $v = 0 \dots 0u$  and  $w = 0 \dots 0u$  (the number of leading 0's need not be equal). Note that  $v \sim w$  implies  $\lambda_v = \lambda_w$ .

Let  $W_{\sim}$  denote the set of equivalence classes of  $W$  under  $\sim$ , whose members we shall call *reduced words*. Each member  $[u]$  of  $W_{\sim}$  contains a unique word of shortest length. As a rule, we shall generally denote the class  $[u]_{\sim}$  by this shortest word. Perhaps an occasional exception is the class  $[0]_{\sim}$ , whose shortest word is the empty word, but we prefer to let 0 denote  $[0]_{\sim}$ . We now define the *length*  $|w|$  of a class  $w \in W_{\sim}$  to be the length of the shortest word in  $w$ . For example, the class  $0 = 00 = 000 = \dots$  has length 0, and the class  $0011 = 011 = 11$  has length 2.

From now on, we shall work entirely on  $W_{\sim}$ . For  $w \in W_{\sim}$ , there is no ambiguity in writing

$$\lambda_w(\mu) = \lim_{m \rightarrow \infty} \rho^m \phi_0^{(m-|w|)} \circ \phi_w(\mu).$$

**5.2. The refinement of  $\Lambda^*$ .** In this section, we shall show that all  $\alpha_i$ 's cannot be an eigenvalue of the discrete Laplacian  $-\widehat{\Delta}_m$  for all  $m > 1$ . Therefore numbers of the form  $\rho^k \lambda_w(\alpha_i)$  with  $k \geq 1$  cannot be in  $\Lambda^*$  and the set of Dirichlet eigenvalues of  $-\Delta$  must be a subset of

$$\Lambda := \{ \rho^k \lambda_w(\mu) : w \in W, \mu \in \mathfrak{F} \text{ if } k = 0 \text{ and } \mu \in \mathfrak{F} \setminus \{ \alpha_i \}_{i=1}^n \text{ if } k \geq 1 \}.$$

**Theorem 14.** *For each  $1 \leq i \leq n$ ,  $\alpha_i$  is not an eigenvalue of the discrete Laplacian  $-\widehat{\Delta}_m$  for all  $m > 1$ . In other words,  $\alpha_i \notin \mathfrak{F}_m$  for all  $m > 1$ . Therefore,  $\rho^l \lambda_\nu(\alpha_i) \notin \Lambda$  for all  $l > 0$ .*

*Proof.* We shall use a dimension counting argument to prove this theorem. By Proposition 4.1 in [Bajorin et al. 2008], the multiplicity of  $4/3$  as an eigenvalue of  $-\Delta_k$  is

$$M_k^{(D)}(4/3) = 2(4n - 3)^k - 3.$$

At step 1, recall that  $|X + \lambda M| = C f_n(\lambda) g_n(\lambda) (\lambda - 4/3)^{8n-9}$ . Hence the eigenvalues of  $-\widehat{\Delta}_1$  are  $\alpha_1, \dots, \alpha_n$  of multiplicity 1,  $\beta_1, \dots, \beta_{n-1}$  of multiplicity 3 and  $4/3$  of multiplicity  $8n - 9$ .

We then consider possible initial eigenvalues at step  $m$  for  $m \geq 2$ . Since the multiplicity of  $4/3$  as a Dirichlet eigenvalue of  $-\widehat{\Delta}_k$  is  $2(4n - 3)^k - 3$ . Hence  $4/3$  is an initial eigenvalue of  $-\widehat{\Delta}_k$  for any  $k$ . Other initial eigenvalues are  $\beta_1, \dots, \beta_{n-1}$  with multiplicity at least 3 since we can construct three eigenfunctions for each  $\beta_i$  ( $1 \leq i \leq n-1$ ) as follows. Indeed, for each  $\beta_i$ , we can use one of the eigenfunctions corresponding to  $-\widehat{\Delta}_1$ , the one which is antisymmetric on the main diagonal, as our building block. We can think the values of this eigenfunction on the upper main diagonal as the positive side of a battery and the lower main diagonal as the negative side. Then at any step  $m \geq 2$ , we can connect a chain of those batteries up to the center square to get values of an eigenfunction on the upper main diagonal. Then for each of the other directions, we can take minus values of the upper main diagonal to get three independent eigenfunctions.

Therefore at step  $m \geq 2$ , the total number of initial eigenvalues of  $-\widehat{\Delta}_m$  is greater than

$$2(4n - 3)^m - 3 + 3(n - 1).$$

Next we investigate the continued eigenvalues at step  $m \geq 2$ . Clearly for each  $1 \leq i \leq n$ , any continued eigenvalue in the  $\alpha_i$ -series will have multiplicity 1. Hence the total number of all eigenvalues in the  $\alpha_i$ -series for all  $i$  is  $n(2n - 1)^{m-1}$ . (For each  $i$ , there are  $2n - 1$  ways to extend at each step and there are  $n$  such series).

For the first  $4/3$ -series (eigenvalues extended from  $4/3$  which appear as an initial eigenvalue corresponding to  $-\widehat{\Delta}_1$  with multiplicity  $2(4n - 3) - 3 = 8n - 9$ ), there are  $n - 1$  ways to extend  $4/3$  at step 2 and  $2n - 1$  ways to extend in the following  $m - 2$  steps, so the total number of eigenvalues in this series is

$$(n - 1)(2n - 1)^{m-2}(2(4n - 3) - 3).$$

Similarly, the second  $4/3$ -series (eigenvalues extended from  $4/3$  which appears as an initial eigenvalue corresponding to  $-\widehat{\Delta}_2$  with multiplicity  $2(4n - 3)^2 - 3$ ) has

$$(n - 1)(2n - 1)^{m-3}(2(4n - 3)^2 - 3)$$

eigenvalues. In general, for the  $k$ -th  $4/3$ -series ( $1 \leq k \leq m - 1$ ), the total number of eigenvalues in that series is

$$(n - 1)(2n - 1)^{m-1-k} (2(4n - 3)^k - 3).$$

The total number of eigenvalues of this type at step  $m$  is

$$(n - 1)(2n - 1)^{m-2} (2(4n - 3) - 3) + (n - 1)(2n - 1)^{m-3} (2(4n - 3)^2 - 3) + \dots + (n - 1)(2n - 1)(2(4n - 3)^{m-2} - 3) + (n - 1)(2(4n - 3)^{m-1} - 3),$$

which can simplified to

$$(4n - 3)^m - (4n - 3)(2n - 1)^{m-1} - (3(n - 1)(2n - 1)^{m-2} + 3(n - 1)(2n - 1)^{m-3} + \dots + 3(n - 1))$$

and this is the (least) total number of the continued eigenvalues in all the  $4/3$ -series.

Notice that each  $\beta_i$  can appear as an initial eigenvalue at any step with multiplicity (at least) 3. We fix  $i$  and consider the first  $\beta_i$ -series (eigenvalues extended from  $\beta_i$  corresponding to  $-\widehat{\Delta}_1$  with multiplicity 3). There are  $2n - 1$  ways to extend at each step, so the total number of eigenvalues in that series is  $3(2n - 1)^{m-1}$ . Similarly, the second  $\beta_i$  series (eigenvalues extended from  $\beta_i$  which appears as an initial eigenvalue corresponding to  $-\widehat{\Delta}_2$  with multiplicity 3) has  $3(2n - 1)^{m-2}$  eigenvalues. In general, for the  $k$ -th  $\beta_i$ -series ( $1 \leq k \leq m - 1$ ) there are  $3(2n - 1)^{m-k}$  eigenvalues in that series. Summing for  $i$  from 1 to  $m - 1$ , the total number of continued eigenvalues corresponding to each  $\beta_i$  is

$$3(2n - 1)^{m-1} + 3(2n - 1)^{m-2} + \dots + 3(2n - 1).$$

So the number of continued eigenvalues for all  $\beta_i$ -series is

$$(n - 1)(3(2n - 1)^{m-1} + 3(2n - 1)^{m-2} + \dots + 3(2n - 1)).$$

Combining all results we have had above, we obtain that the total number of eigenvalues of  $-\widehat{\Delta}_m$  ( $m \geq 2$ ) is at least

$$\underbrace{2(4n - 3)^m - 3 + 3(n - 1)}_{\text{ini e-val of } 4/3 \text{ and } \beta_i} + \underbrace{n(2n - 1)^{m-1}}_{\text{ctd e-val from all } \alpha_i \text{ at step 1}} + \underbrace{(4n - 3)^m - (4n - 3)(2n - 1)^{m-1} - (3(n - 1)(2n - 1)^{m-2} + \dots + 3(n - 1))}_{\text{ctd e-val from } 4/3} + \underbrace{3(n - 1)(2n - 1)^{m-1} + 3(n - 1)(2n - 1)^{m-2} + \dots + 3(n - 1)(2n - 1)}_{\text{ctd e-val from all } \beta_i}$$

An easy calculation shows that the above expression is  $3(4n - 3)^m - 3$ , which is the same as  $\#(V_m \setminus V_0)$ . Therefore we have found all Dirichlet eigenvalues for  $-\widehat{\Delta}_m$ .



Therefore we have proved that  $\alpha_1, \dots, \alpha_n$  can only be initial eigenvalues at step 1 with multiplicity 1. □

In the proof of the above theorem, we actually have found the multiplicities of the Dirichlet eigenvalues of the Laplacian.

**Corollary 15.** *The multiplicities of the Dirichlet eigenvalues are as follows:*

$$\begin{aligned}
 M_m^{(D)}(\lambda_v(\alpha_i)) &= 1 && \text{for all } 1 \leq i \leq n, \\
 M_m^{(D)}(\rho^l \lambda_v(\beta_j)) &= 3 && \text{for all } l, v \text{ and } 1 \leq j \leq n - 1, \\
 M_m^{(D)}(\rho^l \lambda_v(4/3)) &= \begin{cases} 2(4n - 3)^{l+1} - 3 & \text{if } v_1 = 1, 3, \dots, \text{ or } 2n - 3, \\ 0 & \text{otherwise.} \end{cases}
 \end{aligned}$$

In a similar vein, we can use a dimension counting argument to determine the multiplicities of the Neumann eigenvalues, where the Neumann boundary condition means all boundary points satisfy the same type of eigenvalue equations as other interior points. In particular, constant functions are Neumann eigenfunctions corresponding to the eigenvalue zero, which can be extended in  $n$  ways since the  $\beta_i$  ( $i = 1, \dots, n - 1$ ), roots of  $g_n$  are forbidden eigenvalues.

**Theorem 16.** *The multiplicities of the Neumann eigenvalues are as follows:*

$$\begin{aligned}
 M_m^{(N)}(\rho^l \lambda_v(\alpha_i)) &= M_m^{(N)}(\rho^l \lambda_v(\beta_j)) = 0, && \text{for all } i, j, l \text{ and } v, \\
 M_m^{(N)}(\rho^l \lambda_v(0)) &= 1, && \text{for all } l \text{ and } v, \\
 M_m^{(N)}(\rho^l \lambda_v(4/3)) &= \begin{cases} 2(4n - 3)^{l+1} + 1 & \text{if } v_1 = 1, 3, \dots, \text{ or } 2n - 3, \\ 0 & \text{otherwise.} \end{cases}
 \end{aligned}$$

**5.3. Ordering of the eigenvalues.** In this section we shall prove a proposition about the ordering on  $\Lambda$ . To do this, we first define several operations on reduced words.

We need the notion of *parity* of (reduced) words. A word  $w = w_j \dots w_1 \in W_{\sim}$  is said to be *odd* (respectively *even*) if  $w$  contains an odd (respectively even) number of the odd symbols  $1, 3, \dots, N - 1$ . For example, 1 and 203 are odd, while 0 and 1032 are even. The *sign* of  $w$  is

$$\text{sgn}(w) := (-1)^{w_1 + \dots + w_j} = (-1)^{(\# \text{ of odd digits in } w)}.$$

Clearly,  $w$  is even if and only if  $\text{sgn}(w) = +1$ .

We make the simple remark that  $\phi_w$  is a strictly increasing (respectively strictly decreasing) function on the interval  $[0, 4/3]$  if  $w$  is even (respectively odd) as the spectral decimation function  $R$  is a polynomial.

Fix  $w = w_j \dots w_1 \in W_\sim$ , where we choose  $w_j > 0$ . The *right shift* of  $w$  is the word  $w'$  (or  $\sigma(w)$ ) obtained by deleting  $w_1$ :

$$w' := w_j \dots w_2 \in W_\sim.$$

The most important operation on  $W_\sim$  is the *successor* operator  $w \rightarrow w^+$ . For  $w = w_j \dots w_1$ , consider

$$s = w_1 + \text{sgn}(w') \in \Sigma \cup \{-1, N+1\}.$$

Then we define  $w^+ \in W_\sim$  recursively by

$$w^+ := \begin{cases} w' \cdot s & \text{if } s \in \Sigma, \\ (w')^+ \cdot w_1 & \text{if } s \notin \Sigma. \end{cases}$$

We proceed with some examples using  $n = 3$  (and  $N = 4$ ).

**Example 1.** Let  $w = 1230$ , so that  $w' = 123$  and  $w_1 = 0$ . Then  $\text{sgn}(w') = +1$ , which tells us to increase  $w_1$  by 1, provided that the resulting digit  $s$  still lies in  $\Sigma$ . Since  $s = 1 \in \Sigma$ , we end up with  $w^+ = 1231$ . The next several successors are 1232, 1233 and 1234. We shall determine  $(1234)^+$  in Example 3.

**Example 2.** Let  $w = 1224$ , so that  $w' = 122$  and  $w_1 = 4$ . This time  $\text{sgn}(w') = -1$ , so we shall *decrease*  $w_1$  by 1 if we can. The result is  $w^+ = 1223$ . The next several successors are 1222, 1221 and 1220.

**Example 3.** What if  $s = w_1 + \text{sgn}(w') \notin \Sigma$ ? For instance,  $(1234)^+ = (123)^+ 4 = 1224$ , whereas  $(1220)^+ = (122)^+ 0 = 1210$ .

**Example 4.** Here we take  $n = 2$ . It should be clear that iterating  $+$  gives the following list of immediate successors starting from 0:

$$\begin{aligned} 0 &\rightarrow 1 \rightarrow 2 \rightarrow 12 \rightarrow 11 \rightarrow 10 \rightarrow 20 \rightarrow 21 \rightarrow 22 \rightarrow 122 \rightarrow 121 \rightarrow 120 \\ &\rightarrow 110 \rightarrow 111 \rightarrow 112 \rightarrow 102 \rightarrow 101 \rightarrow 100 \rightarrow 200 \rightarrow 201 \rightarrow 202 \rightarrow 212 \\ &\rightarrow 211 \rightarrow 210 \rightarrow 220 \rightarrow 221 \rightarrow 222 \rightarrow 1222 \end{aligned}$$

It is easy to see by induction that  $w \mapsto w^+$  changes just one digit  $w_i$ , say, of  $w$  into  $w_i \pm 1$ . It follows that

$$\text{sgn}(w^+) = -\text{sgn}(w).$$

Regarding length, we see that  $|w| \leq |w^+|$ . Also, inequality holds only when  $w = N^k = N \dots N$  for some  $k \geq 0$ ; in that case,  $w^+ = 1w$  and  $|w^+| = |w| + 1$ .

For  $v, w \in W_\sim$ , we write  $v <_+ w$  if  $w = (v^+)^{\dots+}$ . For instance, in Example 4 above, we have

$$0 <_+ 1 <_+ 2 <_+ 12 <_+ \dots <_+ 1222.$$

For two eigenvalues  $\lambda, \mu \in \Lambda$ , we write

$$\lambda < \mu$$

if  $\lambda < \mu$  and if there does not exist any  $\nu \in \Lambda$  such that  $\lambda < \nu < \mu$  (that is,  $\lambda$  and  $\mu$  are consecutive eigenvalues.) Similarly we can define the converse  $>$ .

Recall that if  $i \in \Sigma$  and  $k \geq 0$ , we write  $i^k = i \cdot \dots \cdot i$  (repeated  $k$  times) and if  $w \in W_\sim$ ,  $w_1$  will mean the last digit of  $w$  (except if  $w = 0$ , when we say that  $w_1 = 0$ ).

The ordering of the eigenvalues is stated in the following theorem.

**Theorem 17.** (1) For any  $w \in W_\sim$  and  $\mu, \nu \in [0, 4/3]$ ,

$$\lambda_w(\mu) < \lambda_{w^+}(\nu).$$

(2) Let  $w$  be even. Then

$$\lambda_w(\alpha_1) < \dots < \lambda_w(\alpha_i) < \lambda_w(\beta_i) < \lambda_w(\alpha_{i+1}) < \dots < \lambda_w(\alpha_n) < \lambda_w(4/3).$$

If  $w$  is odd, then all occurrences of  $<$  in the above are replaced with  $>$ .

(3) Let  $w$  be even. Then for any integers  $0 \leq i < k$ ,

$$\rho^i \lambda_{w \cdot N^{k-i}}(4/3) < \rho^{i+1} \lambda_{w \cdot N^{k-i-1}}(4/3).$$

If  $w$  is odd, then  $<$  is replaced with  $>$ . In particular, for any even  $w$  where  $w_1 \neq N$ , for any  $k \neq 0$ , we have  $\rho^k \lambda_w(4/3) < \rho^k \lambda_{w^+}(4/3)$ .

(4) For any odd  $w$ , let us write  $w = v \cdot 0^l$ , where  $v_1 \neq 0$  and  $l \geq 0$ . Define the integer

$$p = \lceil v_1/2 \rceil \in \{1, \dots, n-1\}.$$

Then

$$\lambda_w(\alpha_1) < \rho^{l+1} \lambda_{v^p}(\beta_p) < \lambda_{w^+}(\alpha_1).$$

Before proving the theorem we prove some simple facts.

**Lemma 18.** For any  $w \in W_\sim$  and  $v \in W$ ,  $\lambda_w$  is continuous and strictly monotone on  $[0, 4/3]$  and  $\lambda_{wv} = \rho^{|v|} \lambda_w \circ \phi_v$ .

*Proof.* Since  $\phi_0$  is strictly convex and thus by Lemma 12 in [Zhou 2008],  $\lambda_0$  is convex, strictly increasing and continuous on  $[0, 4/3]$ . Then  $\lambda_w = \rho^{|w|} \lambda_0 \circ \phi_w$  is strictly monotone being a composite of strictly monotone functions.

The fact that  $\lambda_{wv} = \rho^{|v|} \lambda_w \circ \phi_v$  is obvious. □

Now we are ready to prove Theorem 17.

*Proof.* (1) We prove the claim by induction on the length of  $w$ .

If  $|w| = 0$ , then  $w = 0$  and  $w^+ = 1$ . Since  $\phi_0(\mu) < \phi_1(\nu)$ , it follows that

$$\lambda_0(\mu) = \rho \lambda_0(\phi_0(\mu)) < \rho \lambda_0(\phi_1(\nu)) = \lambda_1(\nu).$$

For  $|w| > 0$  we shall treat two cases.

**Case 1.**  $s \in \Sigma$ . If  $w'$  is even, then  $s > w_1$  and hence  $\phi_{w_1}(\mu) < \phi_s(v)$ . As  $\lambda_{w'}$  is strictly increasing,

$$\lambda_w(\mu) = \rho \lambda_{w'}(\phi_{w_1}(\mu)) < \rho \lambda_{w'}(\phi_s(v)) = \lambda_{w^+}(v).$$

Likewise, if  $w'$  is odd, then  $s < w_1$  and  $\phi_{w_1}(\mu) > \phi_s(v)$ . Since  $\lambda_{w'}$  is strictly decreasing, the inequality shown above remains unchanged.

**Case 2.**  $s \notin \Sigma$ . As  $|w'| < |w|$ , by induction we have  $\lambda_{w'}(\phi_{w_1}(\mu)) < \lambda_{(w')^+}(\phi_{w_1}(v))$ . Therefore,

$$\lambda_w(\mu) = \rho \lambda_{w'}(\phi_{w_1}(\mu)) < \rho \lambda_{(w')^+}(\phi_{w_1}(v)) = \lambda_{w^+}(v).$$

(2) This follows trivially, by the monotonicity of  $\lambda_w$ .

(3) By induction, it is enough to prove that

$$\lambda_{wN^k}(4/3) < \rho \lambda_{wN^{k-1}}(4/3).$$

The proof of this statement is easy:

$$\lambda_{wN^k}(4/3) = \rho \lambda_{wN^{k-1}}(\phi_N(4/3)) = \rho \lambda_{wN^{k-1}}(\alpha_n) < \rho \lambda_{wN^{k-1}}(4/3).$$

The case where  $w$  is odd is just as obvious.

(4) Given  $p = \lceil v_1/2 \rceil$ , as in the hypothesis, we write  $t = 2p - 1$ .

**Claim.**  $v \leq_+ v't \leq_+ v^+$ . (In fact, if  $v'$  is even, then  $v't = v$ , while if  $v'$  is odd, then  $v't = v^+$ .)

To see this, note that since  $v$  is odd, it follows that  $v'$  is even if and only if  $v_1$  is odd. If  $v'$  is even then  $v_1 = 2p - 1$  and  $t = v_1$ , so  $v't = v$ . Alternatively, if  $v'$  is odd, then  $t = v_1 - 1$  and  $v't = v^+$ .

Together with (1) this implies

$$\lambda_v(\phi_0^{(k)}(\alpha_1)) < \lambda_v(0) \leq \lambda_{v't}(0) \leq \lambda_{v^+}(0) < \lambda_{v^+}(\phi_0^{(k)}(\alpha_1)).$$

Multiplying the terms above by  $\rho^k$  gives

$$\begin{aligned} \rho^k \lambda_v(\phi_0^{(k)}(\alpha_1)) &< \rho^k \lambda_{v't}(0) < \rho^k \lambda_{v^+}(\phi_0^{(k)}(\alpha_1)) \\ &\Leftrightarrow \lambda_{v0^k}(\alpha_1) < \rho^{k+1} \lambda_{v'}(\phi_t(0)) < \lambda_{v^+0^k}(\alpha_1) \\ &\Leftrightarrow \lambda_w(\alpha_1) < \rho^{k+1} \lambda_{v'}(\beta_p) < \lambda_{w^+}(\alpha_1) \end{aligned}$$

where the last statement is due to the fact that  $\beta_p = \phi_{2p-1}(0)$ . □

For each even word  $w$ , write

$$w = uN^k \quad \text{and} \quad w^+ = v0^l,$$

where  $k, l \geq 0$  and  $u_1 \neq N, v_1 \neq 0$ . Set  $p = \lceil v_1/2 \rceil$ . Define sets  $\Lambda_w^{(r)}$  as follows. Let

$$\begin{aligned} \Lambda_w^{(1)} &= \{\lambda_w(\alpha_i), \lambda_w(\beta_j) : i = 1, \dots, n; j = 1, \dots, n - 1\}, \\ \Lambda_w^{(3)} &= \{\lambda_{w^+}(\alpha_i), \lambda_{w^+}(\beta_j) : i = 1, \dots, n; j = 1, \dots, n - 1\}. \end{aligned}$$

By Theorem 17 (2), the order of the elements in  $\Lambda_w^{(1)}$  is

$$\lambda_w(\alpha_i) < \lambda_w(\beta_i) < \lambda_w(\alpha_{i+1}),$$

and in  $\Lambda_w^{(3)}$  is

$$\lambda_{w^+}(\alpha_i) > \lambda_{w^+}(\beta_i) > \lambda_{w^+}(\alpha_{i+1}),$$

for  $i = 1, \dots, n - 1$ . We also define

$$\begin{aligned} \Lambda_w^{(2)} &= \{\rho^i \lambda_{uN^{k-i}}(4/3), \rho^j \lambda_{u^+N^{k-j}}(4/3) : i, j = 1, \dots, k\}, \\ \Lambda_w^{(4)} &= \{\rho^{l+1} \lambda_{v'}(\beta_p)\}. \end{aligned}$$

Since  $u$  is even, by Theorem 17 (3), the order of elements in  $\Lambda_w^{(2)}$  is

$$\begin{aligned} \rho^i \lambda_{uN^{k-i}}(4/3) &< \rho^j \lambda_{uN^{k-j}}(4/3), \\ \rho^i \lambda_{u^+N^{k-i}}(4/3) &> \rho^j \lambda_{u^+N^{k-j}}(4/3) \end{aligned}$$

for  $0 \leq i < j \leq k$ , and

$$\rho^k \lambda_u(4/3) < \rho^k \lambda_{u^+}(4/3).$$

Finally, we define the “ $w$ -subsequence”,  $\Lambda_w$ , for even words  $w$  as

$$\Lambda_w = \bigcup_{r=1}^4 \Lambda_w^{(r)}.$$

For two sets  $S$  and  $T$ , we write  $S \lesssim T$  if the largest element in  $S$  is less than the smallest element in  $T$ .

Theorem 17 implies that if  $i < j$ , then  $\Lambda_w^{(i)} \lesssim \Lambda_w^{(j)}$  and if  $u$  and  $v$  are even words with  $u <_+ v$ , then  $\Lambda_u^{(i)} \lesssim \Lambda_v^{(j)}$  for all  $i$  and  $j$ .

**Theorem 19.** *The set of Dirichlet eigenvalues of Laplacian on  $\mathcal{V}\mathcal{S}_n$  is given by*

$$\Lambda = \bigcup_{w \text{ even}} \Lambda_w.$$

*Proof.* Let  $w \rightarrow w^-$  denote the inverse of  $w \rightarrow w^+$ .

If  $\mu = \lambda_v(\alpha_i)$  or  $\mu = \lambda_v(\beta_i)$ , then  $\mu \in \Lambda_w^{(1)}$  or  $\Lambda_w^{(3)}$  for some even word  $w$ .

If  $\mu = \rho^k \lambda_v(4/3)$  and  $v$  is even, set  $w = vN^k$ . If  $v$  is odd, take  $w = (vN^k)^-$ .

Then  $\mu \in \Lambda_w^{(2)}$  in either case.

If  $\mu = \rho^{l+1} \lambda_v(\beta_p)$  and  $v$  is even, choose  $t = 2p - 1$ . If  $v$  is odd, choose  $t = 2p$ . Set  $u = vt$ . In both cases,  $u$  is odd and  $p = \lceil t/2 \rceil$ . Taking  $w = (u0^p)^-$ , we see that  $\mu \in \Lambda_w$ .

As these are all the possibilities for elements of  $\Lambda$ , the desired result follows.  $\square$

### 6. Weyl’s Theorem

In this section, we describe the asymptotic behavior of the Dirichlet spectrum. Note that because of the existence of gaps, the Weyl counting ratio,  $\rho(x)/x^{d/2}$  with  $\rho(x)$  being the eigenvalue counting function, must drop by a constant factor when  $x$  passes through a gap. Therefore it can not have a limit for any choice of  $d$ . For  $\mathcal{V}\mathcal{S}_n$ , as we have already completely describe the multiplicities and the ordering of the eigenvalues, we can be more specific on the Weyl ratio.

We first consider a bottom part in the spectrum. There are  $3(4n - 3)^m - 3$  eigenvalues corresponding to  $-\Delta_m$  for any  $m$ . If we extend those eigenvalues by using  $\phi_0$ , then we will have the smallest eigenvalues for  $-\Delta_{m+1}$  because the largest of those continued eigenvalues is  $\phi_0(4/3) = \gamma_1 < \beta_1$ , the smallest initial eigenvalue. Therefore, if we extend those  $3(4n - 3)^m - 3$  eigenvalues by using  $\phi_0$  for each  $m' > m$  and pass to the limit, we will obtain the smallest  $3(4n - 3)^m - 3$  eigenvalues for the Laplacian on  $\mathcal{V}\mathcal{S}_n$ . Note that the largest of those eigenvalues on  $\mathcal{V}\mathcal{S}_n$  is  $x_m := \rho^{m-1} \lambda_0(4/3)$ .

Define the Dirichlet eigenvalue counting function

$$\pi(x) = \{\lambda : \lambda \text{ is a Dirichlet eigenvalue and } \lambda \leq x\}.$$

Recall that in the classical case, when the underlying space is a bounded domain in  $\mathbb{R}^d$ , then  $\pi(x)$  has a remarkable property shown by Weyl (see [Lapidus 1991] and references therein):

$$\pi(x) = Cx^{d/2} + o(x^{d/2}).$$

In contrast, Shima [1996] proved the following theorem.

**Theorem 20.** *Let  $\deg R$  denote the degree of the spectral decimation function  $R$ . If  $\deg R < |S| < \rho$ , then*

$$(6-1) \quad 0 < \liminf_{\lambda \rightarrow \infty} \frac{\pi(\lambda)}{\lambda^{d_s/2}} < \limsup_{\lambda \rightarrow \infty} \frac{\pi(\lambda)}{\lambda^{d_s/2}} < \infty,$$

where  $d_s = 2(\log |S| / \log \rho)$  and  $\rho$  is the Laplacian renormalization constant.

The number  $d_s$  is called the spectral dimension and it is not necessarily the same as the Hausdorff dimension. Indeed, in our problem,

$$d_s = 2 \frac{\log(4n - 3)}{\log(2n - 1)(4n - 3)}$$

while the Hausdorff dimension is  $\log(4n - 3)/\log(2n - 1)$ .

Since  $\pi(x_m) = 3(4n - 3)^m - 3$ ,

$$\frac{3(4n - 3)}{(\lambda_0(4/3))^{d_s/2}} = \lim_{m \rightarrow \infty} \frac{\pi(x_m)}{x_m^{d_s/2}} \leq \limsup_{x \rightarrow \infty} \frac{\pi(x)}{x^{d_s/2}}.$$

On the other hand, since the multiplicity of  $x_m$  is  $2(4n - 3)^m - 3$ ,

$$\lim_{x \rightarrow x_m^-} \pi(x) = (4n - 3)^m.$$

Hence

$$\liminf_{x \rightarrow \infty} \frac{\pi(x)}{x^{d_s/2}} \leq \frac{(4n - 3)}{(\lambda_0(4/3))^{d_s/2}}$$

and therefore  $\lim_{x \rightarrow \infty} \pi(x)/x^{d_s/2}$  does not exist. Moreover, given any  $x$ , choose  $m$  such that  $x \in [x_{m-1}, x_m]$ . As  $x_m/x_{m-1} = \rho$ ,

$$\frac{\pi(x_{m-1})}{(4n - 3)x_{m-1}^{d_s/2}} \leq \frac{\pi(x)}{x^{d_s/2}} \leq \frac{(4n - 3)\pi(x_m)}{x_m^{d_s/2}}.$$

Letting  $x \rightarrow \infty$ , we obtain an alternative proof of the inequalities (6-1) for  $\mathcal{V}\mathcal{S}_n$ .

### Acknowledgements

The author thanks Kai-Cheong Chan for many interesting and fruitful discussions on this paper and other related work. He would also like to express his sincere gratitude to Professor Kathryn Hare for her supervision and valuable suggestions on this project.

### References

- [Adams et al. 2003] B. Adams, S. A. Smith, R. S. Strichartz, and A. Teplyaev, "The spectrum of the Laplacian on the pentagasket", pp. 1–24 in *Fractals in Graz 2001*, edited by P. Grabner and W. Woess, Birkhäuser, Basel, 2003. MR 2006g:28017 Zbl 1037.31010
- [Bajorin et al. 2008] N. Bajorin, T. Chen, A. Dagan, C. Emmons, M. Hussein, M. Khalil, P. Mody, B. Steinhurst, and A. Teplyaev, "Vibration modes of 3n-gaskets and other fractals", *J. Phys. A* **41**:1 (2008), 015101, 21. MR 2450694 Zbl 05231786
- [Barlow 1998] M. T. Barlow, "Diffusions on fractals", pp. 1–121 in *Lectures on probability theory and statistics* (Saint-Flour, 1995), edited by P. Bernard, Lecture Notes in Math. **1690**, Springer, Berlin, 1998. MR 2000a:60148 Zbl 0916.60069
- [Drenning and Strichartz 2009] S. Drenning and R. Strichartz, "Spectral decimation on Hambly's homogeneous hierarchical gaskets", Preprint, 2009.
- [Fukushima and Shima 1992] M. Fukushima and T. Shima, "On a spectral analysis for the Sierpiński gasket", *Potential Anal.* **1**:1 (1992), 1–35. MR 95b:31009 Zbl 1081.31501
- [Gibbons et al. 2001] M. Gibbons, A. Raj, and R. S. Strichartz, "The finite element method on the Sierpinski gasket", *Constr. Approx.* **17**:4 (2001), 561–588. MR 2002i:28010 Zbl 0991.28007

- [Goldstein 1987] S. Goldstein, “Random walks and diffusions on fractals”, pp. 121–129 in *Percolation theory and ergodic theory of infinite particle systems* (Minneapolis, Minn., 1984–1985), edited by H. Kesten, IMA Vol. Math. Appl. **8**, Springer, New York, 1987. MR 88g:60245 Zbl 0621.60073
- [Hambly and Kumagai 1999] B. M. Hambly and T. Kumagai, “Transition density estimates for diffusion processes on post critically finite self-similar fractals”, *Proc. London Math. Soc.* (3) **78**:2 (1999), 431–458. MR 99m:60118 Zbl 1027.60087
- [Hambly and Metz 1998] B. M. Hambly and V. Metz, “The homogenization problem for the Vicsek set”, *Stochastic Process. Appl.* **76**:2 (1998), 167–190. MR 99g:60140 Zbl 0930.31005
- [Kigami 1989] J. Kigami, “A harmonic calculus on the Sierpiński spaces”, *Japan J. Appl. Math.* **6**:2 (1989), 259–290. MR 91g:31005 Zbl 0686.31003
- [Kigami 1993] J. Kigami, “Harmonic calculus on p.c.f. self-similar sets”, *Trans. Amer. Math. Soc.* **335**:2 (1993), 721–755. MR 93d:39008 Zbl 0773.31009
- [Kusuoka 1987] S. Kusuoka, “A diffusion process on a fractal”, pp. 251–274 in *Probabilistic methods in mathematical physics* (Katata/Kyoto, 1985), edited by K. Itô and N. Ikeda, Academic Press, Boston, 1987. MR 89e:60149 Zbl 0645.60081
- [Lapidus 1991] M. L. Lapidus, “Fractal drum, inverse spectral problems for elliptic operators and a partial resolution of the Weyl–Berry conjecture”, *Trans. Amer. Math. Soc.* **325**:2 (1991), 465–529. MR 91j:58163 Zbl 0741.35048
- [Lindstrøm 1990] T. Lindstrøm, “Brownian motion on nested fractals”, *Mem. Amer. Math. Soc.* **83**:420 (1990), iv+128. MR 90k:60157 Zbl 0688.60065
- [Malozemov and Teplyaev 2003] L. Malozemov and A. Teplyaev, “Self-similarity, operators and dynamics”, *Math. Phys. Anal. Geom.* **6**:3 (2003), 201–218. MR 2004d:47012 Zbl 1021.05069
- [Metz 1993] V. Metz, “How many diffusions exist on the Vicsek snowflake?”, *Acta Appl. Math.* **32**:3 (1993), 227–241. MR 94m:31010 Zbl 0795.31011
- [Shima 1996] T. Shima, “On eigenvalue problems for Laplacians on p.c.f. self-similar sets”, *Japan J. Indust. Appl. Math.* **13**:1 (1996), 1–23. MR 97f:28028 Zbl 0861.58047
- [Strichartz 2005] R. S. Strichartz, “Laplacians on fractals with spectral gaps have nicer Fourier series”, *Math. Res. Lett.* **12**:2-3 (2005), 269–274. MR 2006e:28013 Zbl 1070.42002
- [Strichartz 2006] R. S. Strichartz, *Differential equations on fractals. A tutorial*, Princeton Univ. Press, 2006. MR 2007f:35003 Zbl 05058263
- [Teplyaev 1998] A. Teplyaev, “Spectral analysis on infinite Sierpiński gaskets”, *J. Funct. Anal.* **159**:2 (1998), 537–567. MR 99j:35153 Zbl 0924.58104
- [Zhou 2008] D. Zhou, “Criteria for spectral gaps of Laplacians on fractals”, Preprint, 2008. to appear in *J. Fourier Anal. Appl.*

Received May 31, 2008. Revised October 5, 2008.

DENGLIN ZHOU  
 UNIVERSITY OF WATERLOO  
 DEPARTMENT OF PURE MATHEMATICS  
 200 UNIVERSITY AVENUE WEST  
 WATERLOO, ON N2L3G1  
 CANADA  
 dzhou@math.uwaterloo.ca