

*Pacific
Journal of
Mathematics*

**KLEIN BOTTLE AND TOROIDAL DEHN FILLINGS
AT DISTANCE 5**

SANGYOP LEE

KLEIN BOTTLE AND TOROIDAL DEHN FILLINGS AT DISTANCE 5

SANGYOP LEE

We determine all hyperbolic 3-manifolds M such that $M(\pi)$ contains a Klein bottle, $M(\tau)$ contains an essential torus, and $\Delta(\pi, \tau) = 5$. As a corollary, we prove that if a hyperbolic 3-manifold M has two slopes π and τ on its boundary torus such that $M(\pi)$ is a lens space containing a Klein bottle and $M(\tau)$ is toroidal, then $\Delta(\pi, \tau) \leq 4$.

1. Introduction

Let M be a compact, connected, orientable 3-manifold with a torus boundary component $\partial_0 M$. A *slope* on $\partial_0 M$ is the isotopy class of an essential simple closed curve in $\partial_0 M$. Given a slope γ on $\partial_0 M$, denote by $M(\gamma)$ the 3-manifold obtained by γ -Dehn filling on M along $\partial_0 M$, that is, $M(\gamma)$ is obtained from M by gluing a solid torus V_γ along $\partial_0 M$ so that γ bounds a meridional disk of V_γ . For two slopes γ_1, γ_2 on $\partial_0 M$, denote by $\Delta(\gamma_1, \gamma_2)$ the distance between the slopes, which is their geometric intersection number.

We shall say that a 3-manifold M is *hyperbolic* if M with its boundary tori removed admits a complete hyperbolic structure with totally geodesic boundary. A Dehn filling on M is said to be *exceptional* if it produces a nonhyperbolic 3-manifold, which is either reducible, boundary-reducible, annular, toroidal, or a small Seifert fiber space. It is a well-known theorem of Thurston that there are only finitely many exceptional Dehn fillings on each boundary torus of M .

Gordon and Wu [2008] determined all hyperbolic 3-manifolds admitting two toroidal Dehn fillings at distance 4 or 5. In this paper, we determine all hyperbolic 3-manifolds M admitting two Dehn fillings at distance 5, one of which yields a Klein bottle, the other yielding an essential torus.

Following [Martelli and Petronio 2006], we use N to denote the *magic manifold*, the exterior of the chain link with three components in S^3 , shown in Figure 1. Using the standard meridian-longitude framing on each boundary component of N , we identify a slope γ with a number in $\mathbb{Q} \cup \{1/0\}$. We denote by $N(r)$ the result of

MSC2000: 57M50.

Keywords: toroidal manifolds, Klein bottles, Dehn fillings.

This research was supported by a Chung-Ang University research grant in 2010.

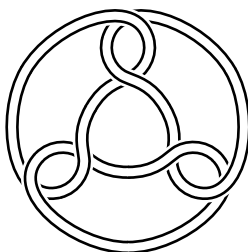

Figure 1. The magic manifold.

Dehn filling on N along a slope corresponding to the number r . Since N admits an automorphism interchanging any two of its boundary components, $N(r)$ is defined independently of the choice of the boundary component of N . Partial Dehn fillings give $N(r, s)$ and $N(r, s, t)$. We also use W to denote the Whitehead link exterior and use $W(r)$ and $W(r, s)$ to denote the corresponding Dehn-filled manifolds. The main result of this paper is the following.

Theorem 1.1. *Let M be a hyperbolic 3-manifold with a torus boundary component $\partial_0 M$. Suppose that there are two slopes π and τ on $\partial_0 M$ such that $M(\pi)$ contains a Klein bottle, $M(\tau)$ contains an essential torus, and $\Delta(\pi, \tau) = 5$. Then $M(\pi)$ is toroidal and either M is equal to either $N(1, -1/3)$, $N(-5/3, -5/3)$, $N(1, 5)$, $N(2, 2)$, or $N(-4, (2n - 1)/2)$ for some integer $n \neq 0, -1$.*

We remark that the manifolds in this theorem are identified with some of the manifolds in [Gordon and Wu 2008, Definition 21.3] as follows: $N(1, -1/3) = M_5$, $N(-5/3, -5/3) = M_7$, $N(1, 5) = M_8$, and $N(2, 2) = M_{12}$. Also, $N(-4) = M_3$ is the Whitehead sister link exterior and $N(1, -1/3) = M_5 = W(4/3)$ and $N(1, 5) = M_8 = W(-4)$. See the proofs of Lemmas 2.2, 6.1, 7.3, 7.4, and 8.1.

Corollary 1.2. *Let M be a hyperbolic 3-manifold with ∂M a torus. Suppose that there are two slopes π and τ on ∂M such that $M(\pi)$ is a lens space containing a Klein bottle and $M(\tau)$ contains an essential torus. Then $\Delta(\pi, \tau) \leq 4$.*

Proof. This follows from [Gordon 1999, Theorem 1.1] and Theorem 1.1. □

In an unpublished paper, Teragaito [2000] obtained the same result.

2. Preliminaries

Let M be a hyperbolic 3-manifold with a torus boundary component $\partial_0 M$ such that $M(\pi)$ contains a Klein bottle and $M(\tau)$ contains an essential torus for two slopes π and τ on $\partial_0 M$. Assume $\Delta(\pi, \tau) = 5$.

Lemma 2.1 [Oh 1997; Wu 1998]. *$M(\pi)$ is irreducible.*

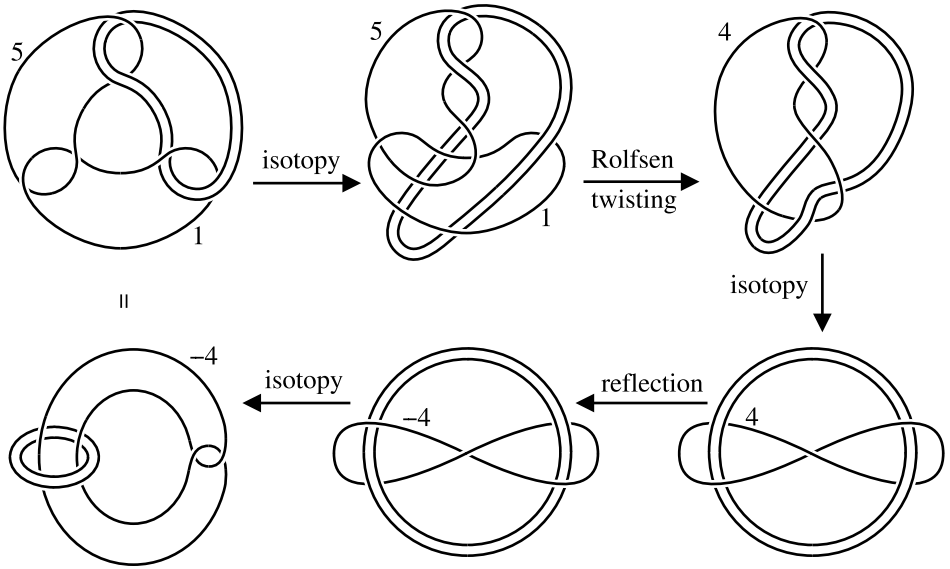

Figure 2. $N(1, 5)$ is homeomorphic to $W(-4)$.

Lemma 2.2. *If $M(\tau)$ contains a Klein bottle, then $M(\pi)$ is toroidal and $M = N(1, 5) = W(-4)$.*

Proof. Suppose that $M(\tau)$ contains a Klein bottle. Then we have $M = W(-4)$ by [Lee 2007, Theorem 1.4]. Figure 2 shows that $N(1, 5) = W(-4)$. In fact, $W(-4)$ is homeomorphic to $M5_1$ in [Martelli and Petronio 2006, Table A.4]. From the table, one sees that M has only one pair of slopes along which Dehn fillings on M give 3-manifolds containing a Klein bottle. Also, the resulting 3-manifolds are toroidal. \square

From now on, we assume that $M(\tau)$ does not contain a Klein bottle.

Let \hat{P} be a Klein bottle in $M(\pi)$, chosen so that the core K_π of the attached solid torus V_π intersects \hat{P} transversely and minimally among all Klein bottles in $M(\pi)$. Then $\hat{P} \cap V_\pi$ is a union of meridian disks of V_π , u_1, \dots, u_p , numbered successively along V_π . Similarly, we choose an essential torus \hat{T} in $M(\tau)$ such that $\hat{T} \cap V_\tau$ is a union of meridian disks of V_τ , v_1, \dots, v_t , where t is minimal.

Let $P = \hat{P} \cap M$ and $T = \hat{T} \cap M$. We may assume that P and T meet transversely. Then $P \cap T$ is a union of circles and arcs. In the usual way, the arc-components of $P \cap T$ define two labeled graphs G_P and G_T on \hat{P} and \hat{T} , respectively. The vertices of G_P and G_T are the meridian disks u_1, \dots, u_p and v_1, \dots, v_t , respectively, and the edges are the arc-components of the intersection. A point in $\partial u_x \cap \partial v_y$ is labeled y in G_P and x in G_T . In G_P and G_T , labels $1, \dots, t$ and $1, \dots, p$ respectively appear in order around each vertex, repeating Δ times.

Let q_1, q_2, q_3, q_4, q_5 be the points in $\partial u_x \cap \partial v_y$, which are successively numbered along ∂u_x . Then the points appear in the order of $q_d, q_{2d}, q_{3d}, q_{4d}, q_{5d}$ on ∂v_y in some direction. The number d is called a *jumping number*, and $d = 1$ or 2 . See [Gordon and Wu 1999, Lemma 2.10].

Orient the boundary circles of P (respectively T) so that they are mutually homologous on $\partial_0 M$. Every edge of G_P (respectively G_T) has a rectangular neighborhood R whose opposite sides are contained in two (or possibly one) boundary components of P (respectively T). We say the edge is *positive* if some orientation of ∂R is compatible with the orientations of the boundary components. Otherwise, we say it is *negative*. Then we have the *parity rule*: an edge is positive in one graph if and only if it is negative in the other.

Let $G = G_P$ or G_T . We call an edge in G a *level edge* if it has the same label at its endpoints; we call it an *x-edge* if one of its endpoints is labeled x . Let G^+ denote the subgraph of G consisting of all positive edges, and for a label x , let $G^+(x)$ denote the subgraph of G^+ consisting of all x -edges of G^+ . A disk face of $G^+(x)$ is called an *x-face*. The boundary of an x -face is called a *Scharlemann cycle* if the x -face is a disk face of G . Note that each edge of a Scharlemann cycle has two consecutive labels, say x and $x + 1$, at its endpoints. In this case, the Scharlemann cycle is called an $(x, x + 1)$ -*Scharlemann cycle*. A Scharlemann cycle of length 2 is called an *S-cycle*. A cycle of positive edges is called an *extended Scharlemann cycle* if it immediately surrounds a Scharlemann cycle. Let \bar{G} denote the *reduced graph* of G , the graph obtained by amalgamating parallel edges of G into a single edge. The *weight* of an edge \bar{e} of \bar{G} is the number of the edges of G in \bar{e} .

We call a vertex u_x of G_P a *level vertex* if there exists a positive level x -edge in G_T . Also, we call a vertex v_x of G_T a *Scharlemann vertex* if there exists a Scharlemann cycle with label x in G_P . If e is a positive level x -edge in G_T , then $u_x \cup e$ has a Möbius band neighborhood in \hat{P} .

Lemma 2.3. *Suppose that $p \geq 2$. Then G_T satisfies the following.*

- (1) *At most two labels of G_T can be labels of positive level edges.*
- (2) *G_T cannot contain a Scharlemann cycle.*
- (3) *Any family of parallel positive edges in G_T contains at most $p/2 + 1$ edges. If the family contains $p/2 + 1$ edges, then the two outermost edges of the family are level.*
- (4) *Any family of parallel negative edges in G_T contains at most p edges.*

Proof. See the proof of [Lee and Teragaito 2008, Lemma 6.2]. □

Lemma 2.4. *G_P satisfies the following. Assume $t \geq 3$ in (6) and (7).*

- (1) *If G_P contains a Scharlemann cycle, then \hat{T} is separating in $M(\tau)$.*

- (2) *The edges of any Scharlemann cycle of G_P cannot be contained in a disk in \widehat{T} .*
- (3) *If $t > 2$, then G_P cannot contain an extended Scharlemann cycle.*
- (4) *If G_P contains two Scharlemann cycles on disjoint label pairs $\{a, a + 1\}$ and $\{b, b + 1\}$, then $a \equiv b \pmod{2}$.*
- (5) *G_P has at most four labels of Scharlemann cycles, that is, G_T has at most four Scharlemann vertices.*
- (6) *Any family of parallel positive edges in G_P contains at most $t/2 + 1$ edges. If t is odd, then the family contains less than $t/2$ edges.*
- (7) *Any family of parallel negative edges in G_P contains at most $t + 1$ edges. If G_P contains $t + 1$ parallel negative edges, then $G_T^+ = G_T$.*

Proof. For (1)–(5), see [Gordon and Wu 2008, Lemma 2.2, parts (4), (5) and (6), and Lemma 2.3, parts (2) and (4)], and for (6) and (7), see [Lee and Teragaito 2008, Lemma 2.5, parts (ii) and (iii)] and [Valdez-Sánchez 2007, Proposition 3.4]. \square

Lemma 2.5 [Gordon 1998, Lemma 2.1]. *No two edges are parallel in both graphs G_P and G_T .*

Lemma 2.6. *G_P cannot contain two S -cycles on disjoint label pairs.*

Proof. If G_P contained two S -cycles on disjoint label pairs, then the construction as in the proof of [Gordon and Luecke 1995, Lemma 3.10] would give a Klein bottle in $M(\tau)$, contradicting our assumption. \square

For any submanifold A of a manifold X , we will use $\eta(A)$ to denote a closed regular neighborhood of A in X .

3. Generic case

In this section we will show that the generic case $p \geq 3$ and $t = 3$ or $t \geq 5$ cannot happen. To do this, we first estimate the number of negative (or positive) edge endpoints of the graphs G_P and G_T . Note that the total number of edge endpoints of each graph is $\Delta pt = 5pt$.

Using the argument of [Lee 2007, Section 3], one can prove the following two lemmas and proposition. See [Lee 2007, Lemmas 3.2 and 3.3 and Proposition 3.4].

Lemma 3.1. *Assume $p \geq 3$. Let x be a label of G_T that is not a label of a positive level edge. Then any x -face in G_T has at least 4 sides.*

Lemma 3.2. *Assume $p \geq 3$. If G_T contains a positive level x -edge, then G_T cannot contain an x -face.*

Proposition 3.3. *Assume $p \geq 3$.*

- (1) *Any level vertex of G_P has at most $2t$ negative edge endpoints.*

(2) Any nonlevel vertex of G_P has at most $2t - 1$ negative edge endpoints.

In the following lemma, we use an Euler characteristic calculation to give an upper bound for the number of Scharlemann cycles in G_P in terms of the number of negative edge endpoints at a vertex of G_T .

Lemma 3.4. *Suppose that G_T has k ($\geq p$) negative edge endpoints at a vertex v_x . Then G_P contains at least $k - p$ Scharlemann cycles.*

Proof. There is no negative loop edge in G_T , since otherwise \widehat{T} would contain an orientation-reversing curve. Hence G_T has k negative edges incident to v_x and by the parity rule G_P has k positive x -edges.

Let V , E and F be the number of vertices, edges, and disk faces of $G_P^+(x)$, respectively. Then $V = p$, $E = k$, and an Euler characteristic calculation for the graph $G_P^+(x)$ gives $V - E + F \geq \chi(\widehat{P}) = 0$, so $F \geq E - V = k - p$. Recall that each disk face of $G_P^+(x)$ is an x -face in G_P . Hence the number of x -faces in G_P is at least $k - p$, and each contains at least one Scharlemann cycle by [Hayashi and Motegi 1997, Proposition 5.1]. \square

Lemma 3.5. *Let v_x be a vertex of G_T . Suppose that any x -face in G_P has at least 3 sides. Then v_x has at most $3p - 1$ negative edge endpoints.*

Proof. This lemma is essentially [Lee 2007, Lemma 2.7]. Assume for contradiction that v_x has at least $3p$ negative edge endpoints. Let V , E and F be as in the proof of Lemma 3.4. Then $V = p$, $E \geq 3p$, and $F \geq E - V \geq 2p$. Since any x -face in G_P (and hence any disk face of $G_P^+(x)$) has at least 3 sides, we have $2E \geq 3F \geq 3(E - V)$, which gives $E \leq 3V = 3p$. Hence $E = 3p$, $F = 2p$, and every face of $G_P^+(x)$ is a 3-sided disk face. Since every face of $G_P^+(x)$ is a disk face, we can conclude that $G_P = G_P^+$. So, every x -edge in G_P is positive and hence we have $E = 5p$. This is a contradiction. \square

Proposition 3.6. *Assume $t \geq 5$.*

- (1) Any Scharlemann vertex of G_T has at most $3p$ negative edge endpoints.
- (2) Any non-Scharlemann vertex of G_T has at most $3p - 1$ negative edge endpoints.

Proof. If v_x is not a Scharlemann vertex, then any x -face in G_P has at least 3 sides by Lemma 2.4(3), so v_x has at most $3p - 1$ negative edge endpoints by Lemma 3.5. Thus we only need to prove the first statement of the proposition. By Lemma 2.4(5), G_T has at most four Scharlemann vertices. We divide our argument into two cases according to the number of Scharlemann vertices of G_T .

First, suppose G_T has at most three Scharlemann vertices. Then any Scharlemann cycle in G_P has label pair $\{a - 1, a\}$ or $\{a, a + 1\}$ for some label a . Let k be the number of negative edge endpoints of G_T at v_a . Then there are exactly k

positive a -edges in G_P , and by [Lemma 3.4](#) there are at least $k - p$ Scharlemann cycles in G_P . Since $t \geq 5$, no two Scharlemann cycles can share an edge. Since each Scharlemann cycle has at least two edges, the number of positive a -edges in G_P , which is equal to k , is at least $2(k - p)$. So, we have $k \geq 2(k - p)$ and hence $k \leq 2p$. Thus v_a has at most $2p$ negative edge endpoints. If some other vertex v_x of G_T has more than $2p$ negative edge endpoints, then G_P has more than p Scharlemann cycles by [Lemma 3.4](#). This implies that there are more than $2p$ positive a -edges in G_P , which contradicts the fact that v_a has at most $2p$ negative edge endpoints. Hence we conclude that any vertex of G_T has at most $2p$ negative edge endpoints.

Now suppose that G_T has exactly four Scharlemann vertices, say v_1, v_2, v_b and v_{b+1} . Relabeling if necessary, we may assume $b + 1 < p$. By [Lemma 2.4\(4\)](#), we have $1 \equiv b \pmod{2}$. Since G_P cannot contain two S -cycles on disjoint label pairs, we may assume that any Scharlemann cycle on the label pair $\{b, b + 1\}$ has length at least 3. Let m and n be the number of $(1, 2)$ -Scharlemann cycles and $(b, b + 1)$ -Scharlemann cycles in G_P , respectively. If $b = 3$, then G_P may contain $(2, 3)$ -Scharlemann cycles. Let l be the number of $(2, 3)$ -Scharlemann cycles if $b = 3$, and let $l = 0$ otherwise.

Claim. *Let σ_1, σ_2 be $(b, b + 1)$ -Scharlemann cycles. Then σ_1 and σ_2 have the same length and there are two families of parallel edges of G_T such that each family contains the same number of edges from σ_1 and σ_2 .*

Proof. By the existence of $(1, 2)$ -Scharlemann cycles and [Lemma 2.4\(2\)](#), there exists an annulus A in \widehat{T} that contains the edges of σ_1 and σ_2 . The core of A is an essential curve in \widehat{T} . Let $A_{b,b+1}$ be an annulus in ∂V_τ with $A_{b,b+1} \cap \widehat{T} = \partial A_{b,b+1} = \partial v_b \cup \partial v_{b+1}$. Then $F = (A - v_b \cup v_{b+1}) \cup A_{b,b+1}$ is a twice-punctured torus.

Let f_i for $i = 1, 2$ be the disk face of G_P bounded by σ_i . Since f_i is bounded by positive edges, its boundary curve ∂f_i is a nonseparating curve in F . If the two curves ∂f_1 and ∂f_2 are not parallel in F , then we compress F along $f_1 \cup f_2$ to obtain two disks, the boundaries of which are the two boundary curves of F . This implies that either of these disks is a compressing disk for \widehat{T} , which gives a contradiction. So, the two curves ∂f_1 and ∂f_2 cobound an annulus in F and the restriction of the annulus onto $A (\subset T)$ is a finite union of bigons, each realizing the parallelism in A between an edge of σ_1 and an edge of σ_2 . The two border edges of each bigon are parallel in G_T , or the bigon contains some vertices of G_T in its interior. The second possibility can be ruled out using the argument in the proof of [[Lee 2007](#), Lemma 2.8]. \square

Since $(b, b + 1)$ -Scharlemann cycles have length at least 3, there is a family of parallel edges of G_T containing at least two edges from each such cycle. This

family contains at most p edges by [Lemma 2.3\(4\)](#), so we have

$$n \leq p/2.$$

Claim. G_P contains at most $2p$ Scharlemann cycles.

Proof. Let k be the number of negative edge endpoints of G_T at v_2 . Then there are exactly k positive 2-edges in G_P . Since each Scharlemann cycle in G_P has at least two edges and since any two Scharlemann cycles with label 2 cannot share an edge, the number of 2-edges in Scharlemann cycles in G_P is at least $2m + 2l$. Thus we have

$$2l + 2m \leq k.$$

Note that $l + m + n$ is the total number of Scharlemann cycles in G_P . By [Lemma 3.4](#) there are at least $k - p$ Scharlemann cycles in G_P . So, we have

$$k - p \leq l + m + n.$$

Combining the three inequalities above, we obtain

$$l + m \leq k - l - m \leq n + p \leq p/2 + p = 3p/2.$$

Thus we have $l + m + n \leq 3p/2 + p/2 = 2p$. □

By [Lemma 3.4](#) and the previous claim, any vertex of G_T has at most $3p$ negative edge endpoints. □

Lemma 3.7. $p \leq 2$ or $t \leq 4$.

Proof. Assume for contradiction that $p \geq 3$ and $t \geq 5$. Let ℓ and s be the number of level vertices of G_P and Scharlemann vertices of G_T , respectively. Then we have $\ell \leq 2$ and $s \leq 4$ by [Lemma 2.3\(1\)](#) and [Lemma 2.4\(5\)](#). Let K be the number of negative edge endpoints of G_P . Then we have $K \leq 2t\ell + (2t - 1)(p - \ell)$ by [Proposition 3.3](#). On the other hand, by [Proposition 3.6](#), any Scharlemann vertex of G_T has at least $2p$ positive edge endpoints and any non-Scharlemann vertex of G_T has at least $2p + 1$ positive edge endpoints. By the parity rule, K is equal to the number of positive edge endpoints of G_T . So, we have $2ps + (2p + 1)(t - s) \leq K$. Combining these inequalities, we obtain

$$2ps + (2p + 1)(t - s) \leq K \leq 2t\ell + (2t - 1)(p - \ell).$$

This gives $p + t \leq \ell + s \leq 2 + 4 = 6$, which violates our initial assumption. □

Lemma 3.8. If $t = 3$, then $p = 2$.

Proof. Assume $t = 3$. Since the number of edge endpoints of G_T (or G_P) is even, we cannot have $p = 1$.

Let $p \geq 3$. Since $t = 3$, \widehat{T} is a nonseparating torus in $M(\tau)$. So, any vertex of G_T has at most p negative edge endpoints by [Lemma 2.4\(1\)](#) and [Lemma 3.4](#),

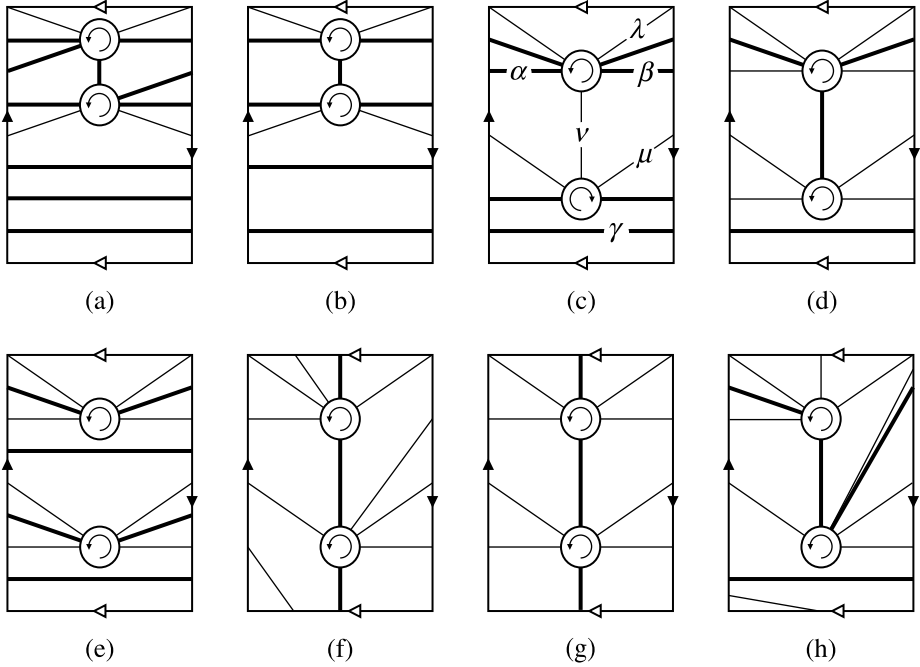

Figure 3. The reduced graph \bar{G}_P .

or equivalently it has at least $4p$ positive edge endpoints. Let K be the number of negative edge endpoints of G_P . Then we have $4pt \leq K \leq 2t\ell + (2t - 1)(p - \ell)$, which gives $\ell \geq 2pt + p \geq 2 \cdot 3 \cdot 3 + 3 > 2$. This contradicts that $\ell \leq 2$. \square

4. The case $p = 2$

In this case we will show that $t = 1, 2$, or 4 . Assume for contradiction that $t = 3$ or $t \geq 5$. If $t \geq 5$, then any vertex of G_T has at most $3p$ negative edge endpoints by Proposition 3.6 and hence G_T has at least $2pt = 4t$ positive edge endpoints. If $t = 3$, we observed in the proof of Lemma 3.8 that any vertex of G_T has at least $4p$ positive edge endpoints, so G_T has at least $4pt = 8t$ positive edge endpoints.

In any case, G_T^+ has at least $2t$ edges. An Euler characteristic calculation shows that G_T^+ has at least t disk faces. By Lemma 2.3(2), each disk face of G_T^+ has at least one level i -edge on its boundary for each $i = 1, 2$. The parity rule implies that each vertex of G_P is a base of a negative loop edge. Then the proof of [Lee 2006, Lemma 5.1] remains valid here to show that \bar{G}_P is a subgraph of one of the graphs in Figure 3, where the thick edges are positive and the thin edges are negative. Note that the number of edges of G_P is $\Delta pt/2 = 5t$.

Lemma 4.1. G_P contains at least $2t$ positive edges.

Proof. Assume not. Then G_T^+ has more than $3t$ edges, so an Euler characteristic calculation shows that it has more than $2t$ disk faces. Since each disk face of G_T^+ has at least one level 1-edge and since any such level 1-edge is shared by at most two disk faces of G_T^+ , the number of positive level 1-edges in G_T is greater than t . Then, in G_P , the family of parallel negative loop edges based at u_1 contains more than t edges. By Lemma 2.4(7), $G_T^+ = G_T$. Then G_T^+ has $5t$ edges and at least $4t$ disk faces. This also implies that the number of positive level 1-edges is at least $2t$. By Lemma 2.4(4), we have $2t \leq t + 1$ and hence $t \leq 1$. This contradicts our assumption that $t = 3$ or $t \geq 5$. \square

For the first two graphs in Figure 3, each negative loop edge of \bar{G}_P has weight at most t by Lemma 2.4(7). Hence G_P has at least $3t$ positive edges, which are divided into at most four families of parallel edges. By Lemma 2.4(6), we have $3t \leq 4 \cdot t/2$ if t is odd and $3t \leq 4 \cdot (t/2 + 1)$ if t is even. Both are impossible, since we assumed $t = 3$ or $t \geq 5$.

For the remaining graphs in the figure, \bar{G}_P has at most three positive edges. By Lemma 4.1, G_P has at least $2t$ positive edges. Hence by Lemma 2.4(6), we have $2t \leq 3 \cdot t/2$ if t is odd and $2t \leq 3 \cdot (t/2 + 1)$ if t is even. The first inequality is impossible. The latter one is possible only if $t = 6$ and \bar{G}_P is a subgraph of the graph in Figure 3(c). But, using (6) and (7) of Lemma 2.4, one can see that the lower vertex of the graph in Figure 3(c) has less than $5t$ edge endpoints in G_P . This is also impossible.

The following is what we proved in this section.

Lemma 4.2. *If $p = 2$, then $t = 1, 2$, or 4 .*

5. The case $t = 4$

In this case we will prove $p = 1$. On the contrary we assume $p \geq 2$ throughout this section.

Lemma 5.1. *Let v_x be a vertex of G_T such that x is not a label of an S -cycle in G_P . Then v_x has at most $3p - 1$ negative edge endpoints, or equivalently it has at least $2p + 1$ positive edge endpoints.*

Proof. Since x is not a label of an S -cycle of G_P , each x -face in G_P has at least 3 sides by Lemma 2.4(3). Hence the result follows from Lemma 3.5. \square

Lemma 5.2. *G_P contains at most $3p - 2$ Scharlemann cycles.*

Proof. There exists a label of G_P that is not a label of an S -cycle by Lemma 2.6. We may assume that the label is 4. We divide the Scharlemann cycles of G_P into two disjoint families; one family \mathcal{S}_1 consists of all Scharlemann cycles having label 2 and the other family \mathcal{S}_2 consists of all Scharlemann cycles having label 4. Let $s_i (\geq 0)$ be the number of all Scharlemann cycles in \mathcal{S}_i for $i = 1, 2$. Then $s_1 + s_2$

is the total number of Scharlemann cycles in G_P . Note that no two Scharlemann cycles in G_P can share an edge.

Since each Scharlemann cycle in \mathcal{S}_2 has at least 3 edges, there are at least $3s_2$ positive 4-edges in G_P . By the parity rule, G_T has at least $3s_2$ negative edge endpoints at v_4 . By Lemma 5.1 we have $3s_2 \leq 3p - 1$ and hence $s_2 \leq p - 1$.

Now let k be the number of negative edge endpoints of G_T at v_2 . Then by Lemma 3.4 we have $k - p \leq s_1 + s_2$. On the other hand, G_P has k positive 2-edges. Since any Scharlemann cycle in \mathcal{S}_1 has at least two edges, we have $2s_1 \leq k$ and hence $2s_1 - p \leq k - p \leq s_1 + s_2$. This gives $s_1 \leq s_2 + p \leq (p - 1) + p = 2p - 1$. We now have $s_1 + s_2 \leq (2p - 1) + (p - 1) \leq 3p - 2$. \square

Lemma 5.3. *Any vertex of G_T has at most $4p - 2$ negative edge endpoints, or equivalently it has at least $p + 2$ positive edge endpoints.*

Proof. This follows from Lemmas 3.4 and 5.2. \square

Lemma 5.4. *Assume $p \geq 3$. Then \widehat{T} is a separating torus in $M(\tau)$.*

Proof. Suppose that \widehat{T} is nonseparating. Then any vertex of G_T has at least $4p$ positive edge endpoints by Lemma 2.4(1) and Lemma 3.4, so G_T contains at least $4pt/2 (= 8p)$ positive edges. Let n be the number of positive edges of \overline{G}_T , and let $q = p/2 + 1$ if p is even and $q = (p + 1)/2$ if p is odd. By Lemma 2.3(3), G_T contains at most nq positive edges. Hence we have $8p \leq nq$, which gives

$$8p/q \leq n.$$

On the other hand, by [Gordon and Wu 2008, Lemma 2.5], \overline{G}_T contains at most $3t$ edges. Hence by (3) and (4) of Lemma 2.3, we have $10p = 5pt/2 \leq nq + (3t - n)p = nq + 12p - np$, which gives

$$n \leq 2p/(p - q).$$

Combining the two inequalities above, we obtain $8p/q \leq n \leq 2p/(p - q)$, which gives $4p \leq 5q$. Solving this inequality, we obtain $3p \leq 10$ if p is even and $3p \leq 5$ if p is odd. Both cases violate the assumption that $p \geq 3$. \square

Lemma 5.5. *Assume $p \geq 3$. Then each component $\overline{\Lambda}$ of \overline{G}_T^+ is contained in an essential annulus but not in a disk on \widehat{T} . There are only five possibilities for $\overline{\Lambda}$, as shown in Figure 4.*

Proof. Since \widehat{T} is separating in G_T , each component of \overline{G}_T^+ has one or two vertices. By Lemma 2.3(3) and Lemma 5.3, each vertex of \overline{G}_T^+ has valency at least 2. Hence no component of \overline{G}_T^+ can be contained in a disk on \widehat{T} , so each component is contained in an essential annulus on \widehat{T} . By [Teragaito 2006a, Lemma 3.5], there are only five possibilities for $\overline{\Lambda}$. \square

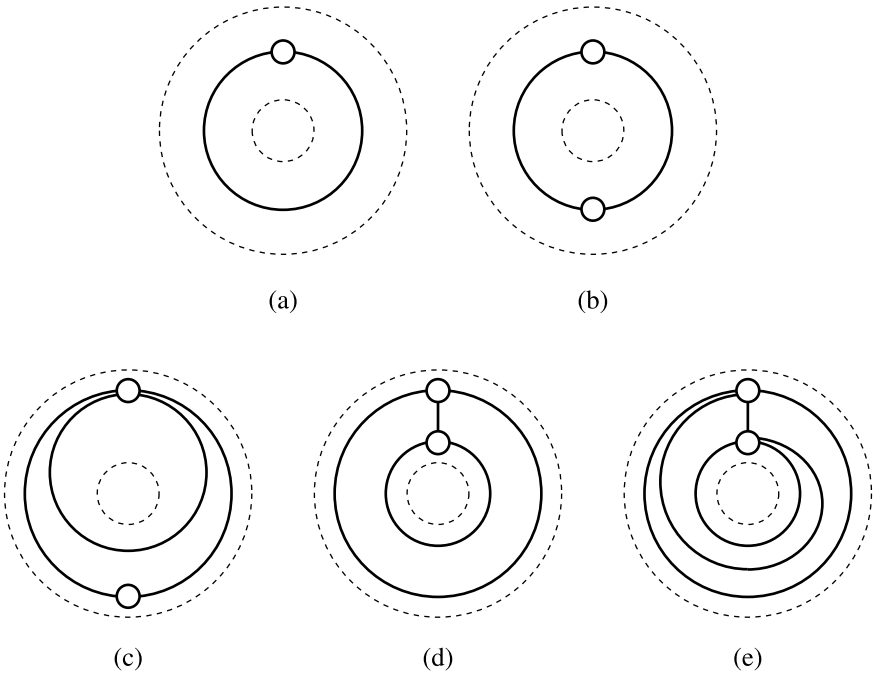

Figure 4. A component of \overline{G}_T^+ with annular support.

Lemma 5.6. $p \leq 2$.

Proof. Assume $p \geq 3$. We may assume that label 4 is not a label of an S -cycle in G_p . Consider the component $\overline{\Lambda}$ of \overline{G}_T^+ containing v_4 . By Lemma 5.1, v_4 has at least $2p + 1$ positive edge endpoints in G_T , so by Lemma 2.3(3) it has valency at least 3 in $\overline{\Lambda}$. Hence $\overline{\Lambda}$ is one of the graphs in Figure 4(c)–(e). In particular, Λ has exactly two vertices v_2 and v_4 . Let K be the number of edge endpoints of Λ . Then by Lemmas 5.1 and 5.3 we have

$$(2p + 1) + (p + 2) \leq K.$$

If x is not a label of a level edge in Λ , then it appears in Λ at most 3 times, since otherwise Λ would contain a 2- or 3-sided x -face, contradicting Lemma 3.1. If x is a label of a level edge in Λ , then it appears in Λ at most 4 times, since otherwise Λ would contain an x -face, contradicting Lemma 3.2. Hence we have

$$K \leq 3(p - \ell) + 4\ell = 3p + \ell \leq 3p + 2,$$

where ℓ is the number of labels of Λ that are a label of a level edge. Combining the two inequalities above, we obtain $(2p + 1) + (p + 2) \leq K \leq 3p + 2$. This gives a contradiction. □

For the remainder of this section, we assume $p = 2$. Note that the number of edges of G_T is $\Delta pt/2 = 20$.

Lemma 5.7. *Any vertex of G_T has at least four positive edge endpoints.*

Proof. By Lemma 5.2, G_P contains at most 4 Scharlemann cycles. Hence by Lemma 3.4, each vertex of G_T has at most 6 negative edge endpoints, or equivalently has at least 4 positive edge endpoints. \square

Using this lemma, one sees that G_T^+ has at least 8 edges. Hence G_T^+ contains at least four disk faces, each of which contains at least one level i -edge for each $i = 1, 2$. This shows that each vertex of \overline{G}_P is a base of a negative loop edge. So, \overline{G}_P is a subgraph of one of the eight graphs in Figure 3.

By Lemma 4.1, G_P has at least 8 positive edges (so, $G_T^+ \neq G_T$). By part (6) of Lemma 2.4, any family of parallel positive edges in G_P contains at most 3 edges. Hence \overline{G}_P^+ has at least 3 edges. It follows that \overline{G}_P is a subgraph of one of the first three graphs in Figure 3.

Assume that \overline{G}_P is a subgraph of the graph in Figure 3(a) or (b). Then \overline{G}_P has exactly two negative edges, each of which containing at most 4 edges of G_P by Lemma 2.4(7). Hence G_P has at least 12 positive edges. In fact, by Lemma 2.4(6), G_P has exactly 12 positive edges and \overline{G}_P is the graph in Figure 3(a). Also, each positive edge of \overline{G}_P contains exactly three edges of G_P . Examining the labels of G_P , one sees that G_P must contain two S -cycles on disjoint label pairs. This contradicts Lemma 2.6.

Hence \overline{G}_P is a subgraph of the graph in Figure 3(c). Label the edges of \overline{G}_P as in the figure, and let $|\cdot|$ denote the weight of the corresponding reduced edge. Then $|\alpha|, |\beta|, |\gamma| \leq 3$ and $|\lambda|, |\mu|, |\nu| \leq 4$. But, the number of edge endpoints of G_P at the lower vertex of the graph in Figure 3(c) is $|\alpha| + |\beta| + 2|\mu| + |\nu| \leq 18$. This is impossible since each vertex of G_P has $\Delta t = 20$ edge endpoints. Hence we conclude that $p = 2$ is impossible.

Summarizing the results obtained in this section, we have the following.

Lemma 5.8. *If $t = 4$, then $p = 1$.*

6. The case $t = 1$

In this case, the reduced graph \overline{G}_T has at most 3 edges. See Figure 5. The number of edges of G_T is $\Delta pt/2 = 5p/2$ (so, p is even). By Lemma 2.3(3) we have $5p/2 \leq 3(p/2 + 1)$ and hence $p \leq 3$. Since p is even, we have $p = 2$ and we can determine the graph pair G_T, G_P as shown in Figure 6. One can see that the jumping number for the graph pair is 1, so the edge correspondence between the two graphs is as shown in the figure.

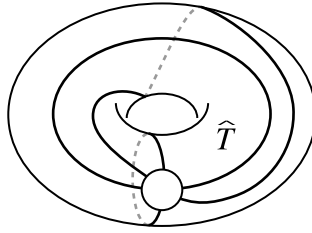

Figure 5. The reduced graph \bar{G}_T .

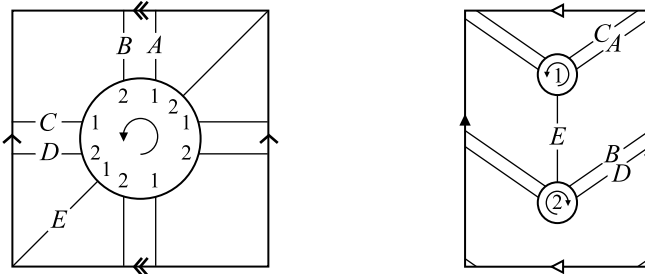

Figure 6. The graph pair G_T, G_P .

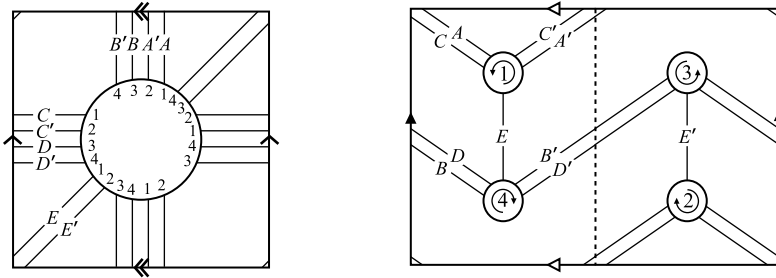

Figure 7. The graph pair G'_T, G_S .

A thin neighborhood $\eta(\hat{P})$ of \hat{P} is a twisted I -bundle over the Klein bottle \hat{P} . Its boundary, $\hat{S} = \partial\eta(\hat{P})$, is a torus. Let $S = \hat{S} \cap M$. As done in Section 2, we construct two labeled graphs G_S and G'_T from the intersection of S and T , where G'_T is obtained by doubling the edges of G_T and G_S double-covers G_P . See Figure 7 for the graphs G'_T and G_S and the edge correspondence between them. The graph G_S is homeomorphic to the graph shown in Figure 8(a).

Let $Z = M(\pi) - \text{Int}(\eta(\hat{P}))$. Then $M(\pi) = \eta(\hat{P}) \cup_{\hat{S}} Z$ and $Z \cap V_\pi$ is a union of two 1-handles V_{41} and V_{23} , where $V_{i,i+1}$ is the part of V_π between two vertices of G_S labeled i and $i + 1$. Let f, g , and h be the faces of G'_T bounded by the edges $A' \cup B$, $A \cup D' \cup E$, and $B' \cup C \cup E'$, respectively. By compressing the genus 3 surface $\partial(\eta(\hat{P}) \cup V_\pi)$ along the three disks f, g , and h , one obtains a 2-sphere

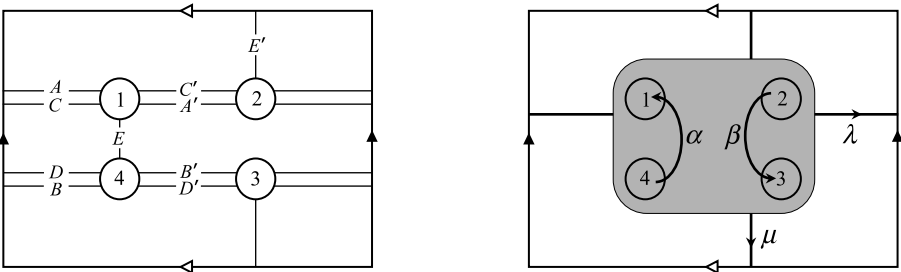

Figure 8. Generators for $\pi_1(Z)$.

in $M(\pi)$, which bounds a 3-ball by the irreducibility of $M(\pi)$. This implies that $\eta(\hat{S} \cup V_{41} \cup V_{23} \cup f \cup g \cup h)$ is Z minus a 3-ball. Thus $\eta(\hat{S} \cup V_{41} \cup V_{23} \cup f \cup g \cup h)$ and Z have the same fundamental group.

To calculate $\pi_1(Z)$, we follow an argument in [Teragaito 2000]. As a base point of Z , we take a disk containing the vertices of G_S as shown in Figure 8(b). The group $\pi_1(Z)$ has four generators $\alpha, \beta, \lambda,$ and μ as shown in the figure, where α and β are represented by the cores of V_{41} and V_{23} , respectively. The two generators λ and μ give a relation $\lambda\mu = \mu\lambda$ and the three disks $f, g,$ and h give three relations $\lambda\alpha\beta = 1, \lambda\alpha^{-2}\beta^{-1} = 1,$ and $\mu\beta\alpha\lambda^{-1}\beta = 1,$ respectively. Hence $\pi_1(Z)$ has the presentation

$$\langle \alpha, \beta, \lambda, \mu : \lambda\mu = \mu\lambda, \lambda\alpha\beta = 1, \lambda\alpha^{-2}\beta^{-1} = 1, \mu\beta\alpha\lambda^{-1}\beta = 1 \rangle.$$

Using the last two relations, one can eliminate two generators λ and μ to obtain $\pi_1(Z) = \langle \alpha, \beta : \alpha^3\beta^2 = 1 \rangle$. This group is isomorphic to the fundamental group of the trefoil knot exterior, so Z is not a solid torus. This implies that \hat{S} is an essential torus in $M(\pi)$.

The graph pair in Figure 7 is homeomorphic to that in [Gordon and Wu 2008, Figure 11.10]. Hence M is homeomorphic to M_5 in the notation of [ibid., Definition 21.3].

Lemma 6.1. *If $t = 1$, then $M(\pi)$ is toroidal and $M = N(1, -1/3) = W(4/3)$.*

Proof. We only need to show that $M = N(1, -1/3) = W(4/3)$. By applying similar moves as in Figure 2, one can see that $N(1, -1/3)$ is homeomorphic to $W(4/3)$. From [Martelli and Petronio 2006, Table A.4], one sees that $N(1, -1/3, -4)$ contains a Klein bottle and $N(1, -1/3, 1)$ is toroidal. Here, $\Delta(-4, 1) = 5$.

We already saw that if $t = 1$, then M is uniquely determined ($M = M_5$). Hence we only need to show $N(1, -1/3)$ contains a properly embedded once-punctured torus with boundary slope 1. By a Rolfsen twisting (see Figure 2), slope 1 on $\partial N(1, -1/3)$ is changed into slope 0 on the boundary torus of $W(4/3)$. It is easy to see that slope 0 is a boundary slope of a once-punctured torus in $W(4/3)$. \square

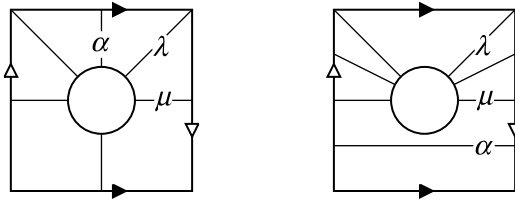

Figure 9. The reduced graph \bar{G}_P .

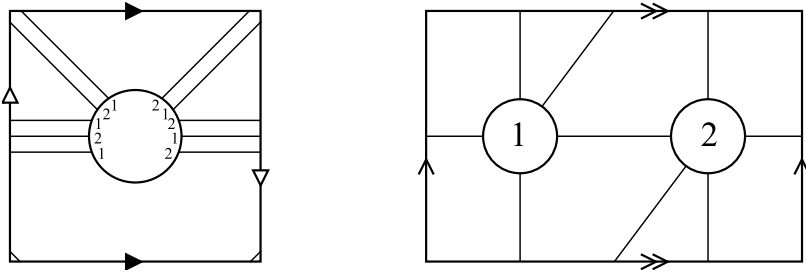

Figure 10. The graph pair G_P, G_T .

7. The case $p = 1$

In this case the reduced graph \bar{G}_P has one of the forms in Figure 9. Label the edges of \bar{G}_P as in the figure. Note that α is positive while λ and μ are negative. We write $G_P = \Gamma_1(|\alpha|, |\lambda|, |\mu|)$ or $\Gamma_2(|\alpha|, |\lambda|, |\mu|)$ according to whether \bar{G}_P is the first or second graph in Figure 9. Up to homeomorphism of \hat{P} , we have $\Gamma_i(a, b, c) \cong \Gamma_i(a, c, b)$ for each $i = 1, 2$.

Lemma 7.1. $|\alpha| > 0$.

Proof. Assume for contradiction that $|\alpha| = 0$. We have $|\lambda|, |\mu| \leq t + 1$ by Lemma 2.4(7). The number of edges of G_P is $\Delta pt/2 = 5t/2$ (so, t must be even) and hence $5t/2 = |\lambda| + |\mu| \leq 2t + 2$, giving $t \leq 4$.

If $t = 4$, then $|\lambda| = |\mu| = 5$; this is impossible by [Teragaito 2006b, Lemma 8.6]. If $t = 2$, then $(|\lambda|, |\mu|) = (2, 3)$ or $(3, 2)$. We may assume $(|\lambda|, |\mu|) = (2, 3)$. Then using Lemma 2.5, we can determine the graph pair G_P, G_T as in Figure 10. But a jumping number argument as in the first paragraph of the proof of [Godal and Teragaito 2005, Proposition 8.7] rules out this possibility. \square

Lemma 7.2. $t \geq 4$ is impossible.

Proof. Assume $t \geq 4$. Since $|\alpha| > 0$, $G_T^+ \neq G_T$ and hence we have $|\lambda|, |\mu| \leq t$ by Lemma 2.4(7). The total number of edges of G_P is $\Delta pt/2 = 5t/2$, so $|\alpha| \geq t/2$.

Hence $|\alpha| = t/2$ or $t/2 + 1$ by Lemma 2.4(6). But $|\alpha| = t/2 + 1$ is impossible by [Teragaito 2006b, Lemma 8.12]. Thus $G_P = \Gamma_1(t/2, t, t)$ or $\Gamma_2(t/2, t, t)$. The latter is impossible by [Teragaito 2006b, Lemma 8.11], the former is possible only if $t = 4$

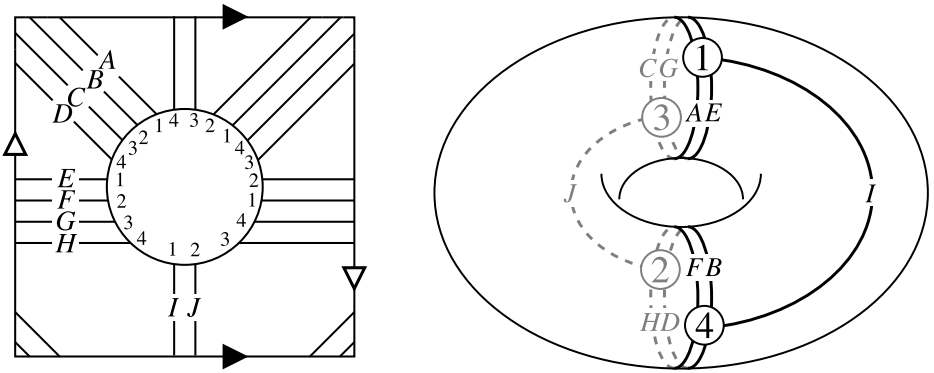

Figure 11. The graph pair G_P, G_T .

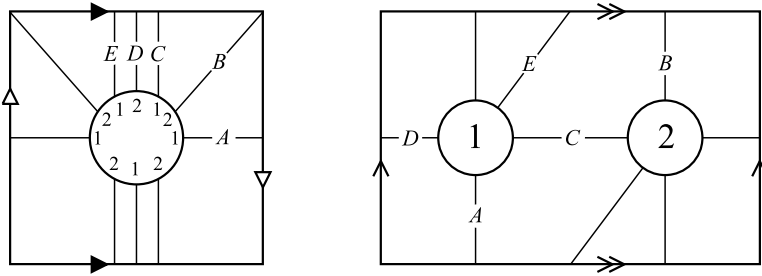

Figure 12. The graph pair G_P, G_T .

by [Teragaito 2006b, Lemma 8.10], and the graph pair G_P, G_T is determined as in Figure 11.

Let b_1, b_2 and b_3 be the bigon faces of G_P bounded by the edges $A \cup B, C \cup D$, and $I \cup J$, respectively. Let $V_{i,i+1}$ be the part of V_τ between v_i and v_{i+1} for each $i \in \{1, 2, 3, 4\}$. Then for each $j = 1, 2$, shrinking V_{12} and V_{34} to their cores in $b_j \cup b_3 \cup V_{12} \cup V_{34}$ gives a Möbius band B_j in $M(\tau)$ such that $\partial B_j \subset \widehat{T}$. Isotope B_1 so that $B_1 \cap B_2 = \partial B_1 = \partial B_2$. Then $B_1 \cup B_2$ is a Klein bottle in $M(\tau)$, contradicting our assumption that $M(\tau)$ does not contain a Klein bottle. \square

Hence $t = 2$. The proof of [Goda and Teragaito 2005, Proposition 8.7] shows that the only two possibilities for G_P are $G_P \cong \Gamma_1(3, 1, 1)$ or $\Gamma_2(3, 2, 0)$.

Lemma 7.3. *If $G_P \cong \Gamma_1(3, 1, 1)$, then $M(\pi)$ is toroidal and $M = N(2, 2)$.*

Proof. Using Lemma 2.5, we can determine the graph pair G_P, G_T as in Figure 12. The jumping number is 1 and the edge correspondence is as shown in the figure. The graph pair G_S, G'_T obtained from G_P and G_T as in Section 6 is shown in Figure 13.

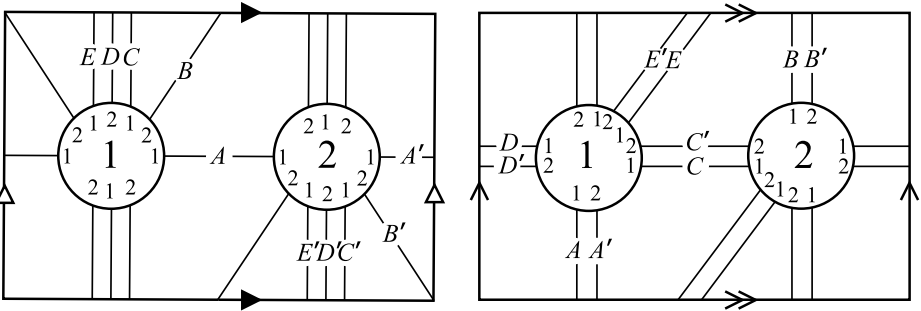

Figure 13. The graph pair G_S, G'_T .

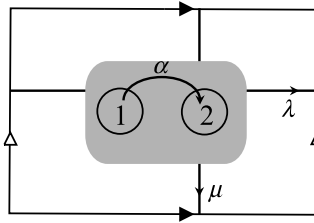

Figure 14. Generators for $\pi_1(Z)$.

Let $Z = M(\pi) - \text{Int}(\eta(\hat{P}))$ and $V_{12} = V_\pi \cap Z$, and let f and g be the faces of G'_T bounded by the edges $A' \cup C \cup E'$ and $B \cup C' \cup E$, respectively. Compressing the genus 2 surface $\partial(\eta(\hat{P}) \cup V_\pi)$ along the disks f and g gives a 2-sphere in $M(\pi)$, which bounds a 3-ball. Hence $\pi_1(\eta(\hat{S} \cup V_{12} \cup f \cup g)) \cong \pi_1(Z)$.

As a base point, we take a disk containing the two vertices of G_S as shown in Figure 14. The group $\pi_1(Z)$ has three generators α, λ , and μ as in the figure, where α is represented by the core of V_{12} . The torus \hat{S} gives a relation $\lambda\mu = \mu\lambda$ and the disks f and g give two relations $\lambda\alpha\mu\alpha^{-1}\mu\alpha = 1$ and $\mu\alpha\mu\alpha^{-1}\mu^{-1}\alpha^{-1} = 1$. Hence $\pi_1(Z)$ has the presentation

$$\langle \alpha, \lambda, \mu : \lambda\mu = \mu\lambda, \lambda\alpha\mu\alpha^{-1}\mu\alpha = 1, \mu\alpha\mu\alpha^{-1}\mu^{-1}\alpha^{-1} = 1 \rangle.$$

One sees that $\pi_1(Z) = \langle \alpha, \mu : \alpha\mu\alpha = \mu\alpha\mu \rangle$, which is isomorphic to the fundamental group of the trefoil knot exterior. This implies that Z is not a solid torus. Hence \hat{S} is an essential torus in $M(\pi)$.

The graph pair G_S, G'_T is shown in [Gordon and Wu 2008, Figure 20.4] with the order reversed. By [ibid., Theorem 21.4], M is homeomorphic to M_{12} in the notation of that paper. They proved in [ibid., Lemma 22.2] that M_{12} is the double branched cover of the tangle in [ibid., Figure 22.12(b)], which is the tangle on the top left in Figure 15. Using isotopies and the Montesinos trick, one can see that $M = M_{12}$ is homeomorphic to the 3-manifold in the top right of Figure 15, where a

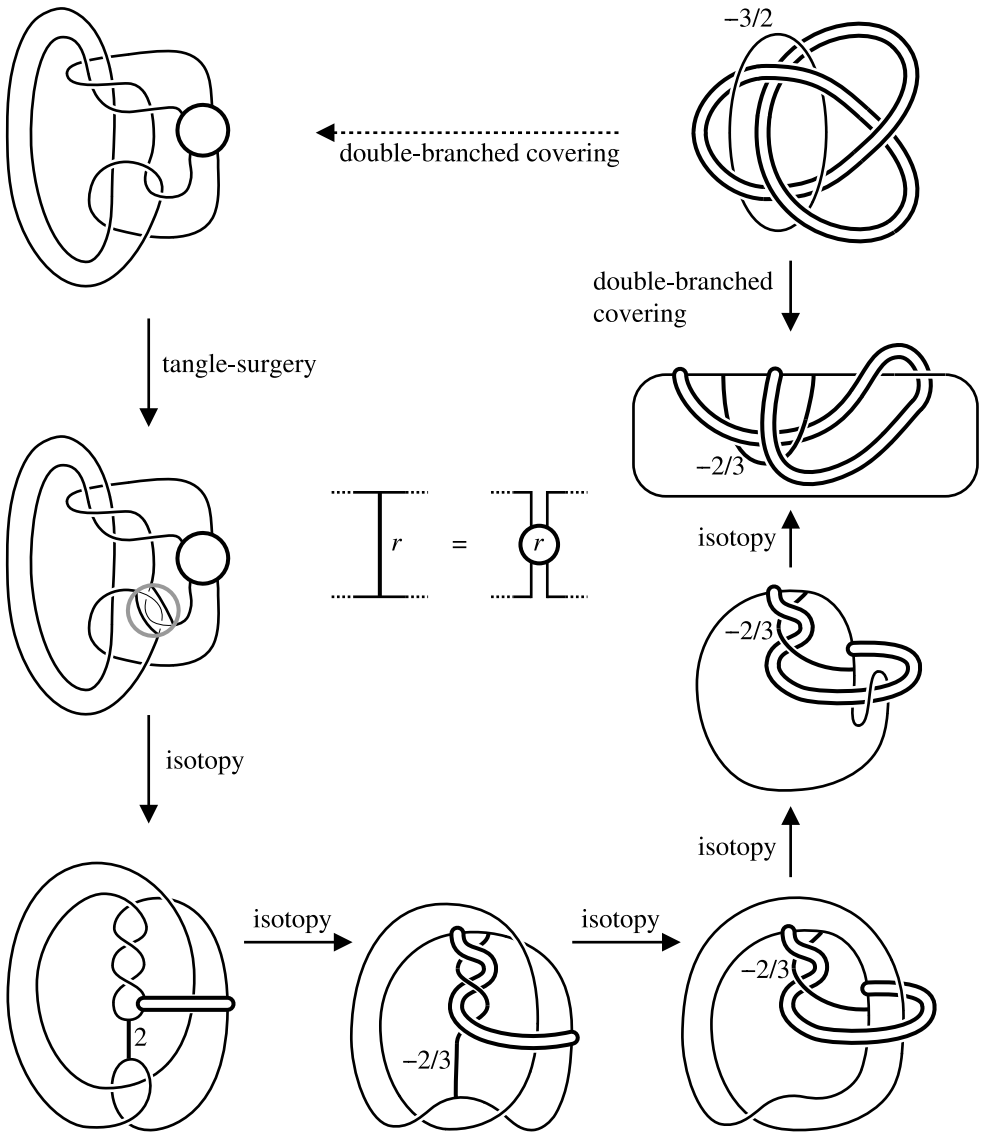

Figure 15. A surgery description for M_{12} .

thick arc with a rational number r represents a rational tangle of slope r as shown in the center of the figure. (See [Eudave-Muñoz 2002, Section 2] for the definition of rational tangles.) Figure 16 shows that $M = M_{12}$ is homeomorphic to $N(2, 2)$. See [Gompf and Stipsicz 1999, Chapter 5]. \square

Let V be a solid torus and K a knot on ∂V that wraps around V in the longitudinal direction l times and in the meridional direction m times. Push K into

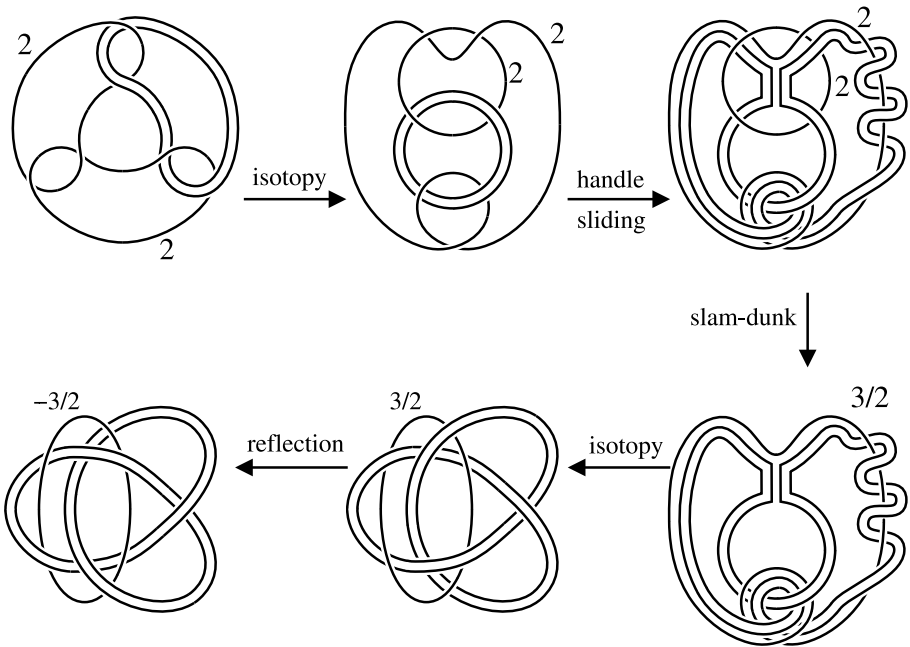

Figure 16. $N(2, 2)$ is homeomorphic to M_{12} .

the interior of V and remove its open regular neighborhood from V . The resulting manifold will be denoted by $C(l, m)$ and called a *cable space* of type (l, m) .

Lemma 7.4. *If $G_P \cong \Gamma_2(3, 2, 0)$, then $M(\pi)$ is toroidal and $M = N(-4, \frac{1}{2}(2n-1))$ for some integer $n \neq 0, -1$.*

Proof. Note that $\Gamma_2(3, 2, 0) \cong \Gamma_2(3, 0, 2)$. Assume $G_P \cong \Gamma_2(3, 0, 2)$. Using Lemma 2.5, we can determine G_T as in Figure 12. Each face of G_T is a disk, so there is no circle component of $P \cap T$. There exists a nondisk face in G_P ; this face is homeomorphic to a Möbius band. Let k be an orientation-reversing curve on the nondisk face.

Let $X = M - \text{Int}(\eta(k))$, $\hat{B} = \hat{P} - \text{Int}(\eta(k))$, $B' = \hat{P} \cap \eta(k)$ and $B = X \cap \hat{B}$. Then \hat{B} and B' are Möbius bands and B is a once-punctured Möbius band. Since M is bounded by a single torus (see [Lee 2007, Theorem 1.3]), X is bounded by two tori ∂M and $\partial \eta(k)$. Let $T_0 = \partial M$, $T_1 = \partial \eta(k)$, and $\partial_i B = \partial B \cap T_i (i = 0, 1)$. Let $X(\pi) = X \cup V_\pi$ and $X(\tau) = X \cup V_\tau$.

Note that \hat{T} is essential in $X(\tau)$; it is incompressible in $X(\tau)$, since otherwise it would be compressible in $M(\tau)$, and it is not boundary-parallel in $X(\tau)$, since otherwise it would bound a solid torus in $M(\tau)$. Since G_P contains Scharlemann cycles, by Lemma 2.4(1), \hat{T} is separating in $M(\tau)$ (and hence in $X(\tau)$).

Claim. X is hyperbolic.

Proof. We first show that X is irreducible. On the contrary, suppose that X contains an essential sphere Q . Since M is irreducible, Q is separating in X . In particular, Q separates the two boundary components of X . By an isotopy of Q , we may assume that Q meets each of B and T transversely. We may also assume that Q meets each of B and T minimally among all essential spheres in X . Then Q and T are disjoint, since otherwise T would be compressible. But Q and B cannot be disjoint because B has one boundary component on each of T_0 and T_1 . Since Q and T are disjoint, each component of $Q \cap B$ is parallel to $\partial_1 B$ in B . Compressing \hat{P} along a disk component of $Q - B$ gives a projective plane in $M(\pi)$. This contradicts [Jin et al. 2003, Theorem 1.1]. Hence X is irreducible.

Each T_i for $i = 0, 1$ is incompressible in X , since otherwise after compression it would become a sphere bounding a 3-ball by the irreducibility of X , implying that X is a solid torus. Thus X is boundary-irreducible.

The manifold M , which is obtained from X by Dehn filling, is hyperbolic. Hence X cannot be Seifert fibered.

We only need to prove that X is atoroidal. Suppose that X contains an essential torus U . Since M is atoroidal and irreducible, U separates X into two components. Let X_0 and X_1 be the two components, where $T_i \subset X_i$ for $i = 0, 1$ and $X_1 \cup \eta(k)$ is a solid torus. We may assume that U was chosen so that X_0 contains no essential torus in its interior. We also assume that U intersects each of B and T transversely and minimally. Since M is orientable, each component of $U \cap B$ is parallel in B to either $\partial_0 B$ or $\partial_1 B$.

Suppose some components of $U \cap B$ are parallel to $\partial_0 B$. Let $A (\subset B)$ be the annulus cut off by the outermost such component. Then A is contained in X_0 and intersects the tori T_0 and U . The boundary circle of A on U is essential, since otherwise X would be boundary-reducible. The frontier of $\eta(T_0 \cup A \cup U)$ is a torus in X_0 . Since X_0 is irreducible and atoroidal, the torus bounds a solid torus in X_0 . This implies that X_0 is a cable space, which contradicts the hyperbolicity of M .

Hence all the components of $U \cap B$ are parallel to $\partial_1 B$. The outermost component cuts off an annulus $A' (\subset B)$, which lies in X_1 . One boundary component of A' is $\partial_1 B$ and the other is an essential curve in U . Since $A' \cup B'$ is a Möbius band with boundary on U , $\eta(U \cup A' \cup B') = \eta(U \cup A') \cup \eta(k)$ is homeomorphic to the cable space $C(2, 1)$. One boundary component of $\eta(U \cup A' \cup B')$ is parallel to U and the other bounds a solid torus J in X_1 since otherwise either that component would be essential in M , contradicting the hyperbolicity of M , or it would compress into an essential sphere in X_1 , contradicting the irreducibility of X . The core of A' , which is a Seifert fiber of $\eta(U \cup A' \cup B')$, is homotopic to the core of J , since otherwise U would be an essential torus in M , contradicting the hyperbolicity of M again. This implies that $X_1 \cong \eta(U \cup A') \cup J \cong U \times I$, showing that U is boundary-parallel in X . This contradicts the choice of U . \square

Neither $X(\pi)$ nor $X(\tau)$ is hyperbolic (the former contains a Möbius band \widehat{B} and the latter contains an essential torus \widehat{T}) and $\Delta(\pi, \tau) = 5$, so it follows from [Lee 2007, Theorem 1.1] that X is the exterior of the Whitehead sister link. Hence M is the result of a Dehn filling on the link exterior.

The results of exceptional Dehn fillings on the Whitehead sister link exterior are shown in [Martelli and Petronio 2006, Table A.1]. From the table, one sees that each of $X(\pi)$ and $X(\tau)$ contains a unique essential torus cutting it into the trefoil knot exterior and the cable space $C(2, 1)$. Let E and C denote the knot exterior and the cable space, respectively. Let $V = \eta(k)$ and let T_2 be the common boundary torus of E and C in $X(\pi)$. Then $X(\pi) = E \cup_{T_2} C$, $M(\pi) = E \cup_{T_2} (C \cup_{T_1} V)$, and $\partial C = T_1 \cup T_2$.

Claim. T_2 is an essential torus in $M(\pi)$.

Proof. Suppose that $C \cup V$ is a solid torus. (Otherwise, $T_2 (= \partial(C \cup V))$ is an essential torus in $M(\pi)$.) Consider the curves on T_2 . By an (r, s) -curve, we mean a curve on T_2 that wraps around the solid torus $C \cup V$ in the longitudinal direction r times and in the meridional direction s times. Then $C \cup V$ is a fibered solid torus whose regular fibers on T_2 are $(2, 1)$ -curves.

Note that E and C are Seifert fiber spaces whose fibers intersect exactly once in their common boundary T_2 . See [Martelli and Petronio 2006, Table A.1]. Suppose that an (a, b) -curve is a regular fiber of E . Then we have $a - 2b = 1$ and hence $a = 2b + 1$. This implies that $M(\pi)$ is a Seifert fiber space over the 2-sphere with three exceptional fibers of indices 2, 3, and $|2b + 1|$. (Note that E is a Seifert fiber space over the disk with two exceptional fibers of indices 2 and 3.) Such a Seifert fiber space does not contain a Klein bottle, which contradicts the assumption that $M(\pi)$ contains a Klein bottle. □

Since the Whitehead sister link exterior X has a self-homeomorphism interchanging its two boundary tori, we may assume that T_0 is the knotted boundary torus of X . Let $X(r_0, r_1)$ denote the 3-manifold obtained from X by performing a Dehn filling on T_i along slope r_i for each $i = 0, 1$. Partial Dehn fillings give $X(r_0) = X(r_0, \cdot)$ and $X(\cdot, r_1)$. Recall that M is obtained from X by performing a Dehn filling along the torus T_1 , so $M = X(\cdot, r)$ for some $r \in \mathbb{Q} \cup \{1/0\}$.

By [ibid., Proposition 1.5] we have

$$N(-\frac{3}{2}, \alpha, \beta) = N\left(-4, -\frac{\alpha+1}{\alpha+2}, -\beta-3\right) = N\left(-\frac{3}{2}, -\frac{2\alpha+5}{\alpha+2}, -\frac{2\beta+5}{\beta+2}\right).$$

Using this, one sees

$$N(-4, r, s) = N\left(-4, -\frac{r+2}{r+1}, -\frac{s+2}{s+1}\right).$$

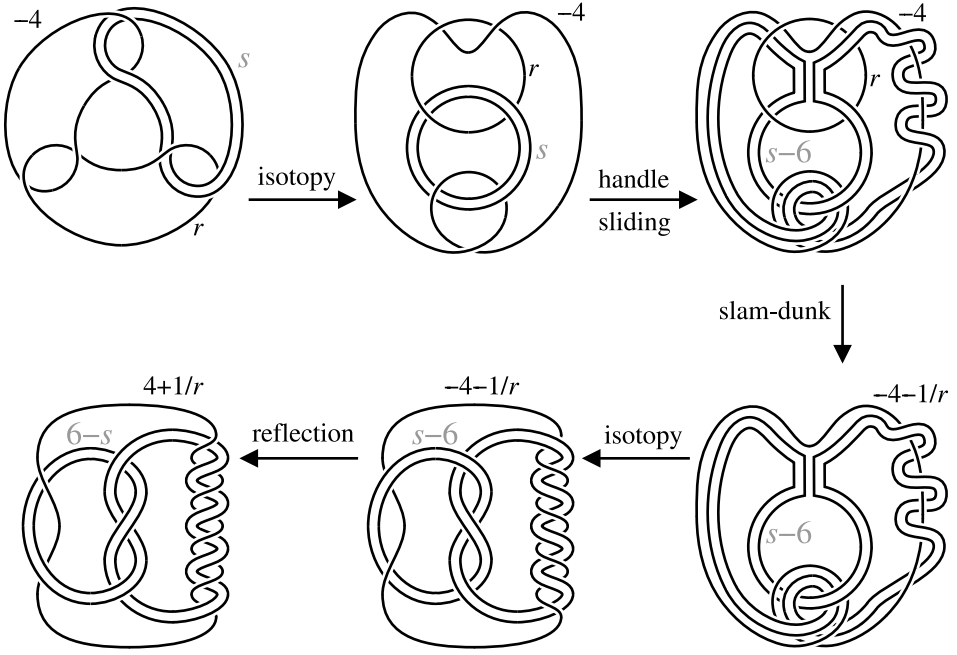

Figure 17. $N(-4)$ is homeomorphic to the Whitehead sister link exterior.

In particular, we have

$$N(-4, r) = N\left(-4, -\frac{r+2}{r+1}\right).$$

Figure 17 shows that

$$N(-4, r) = X(\cdot, 4 + 1/r) \quad \text{and} \quad N(-4, r, s) = X(6 - s, 4 + 1/r).$$

It is known that the Whitehead sister link exterior X has exactly 5 exceptional slopes on any boundary component (see [ibid., Table A.1]). One can see that the set \mathcal{E} of exceptional slopes of X on T_0 is $\mathcal{E} = \{1/0, 6, 7, 8, 9, 13/2\}$. Here, $\pi, \tau \in \mathcal{E}$ and $\{\pi, \tau\} = \{9, 13/2\}$. (Note that $\Delta(9, 13/2) = 5$.)

Assume $\pi = 13/2$. Then $\tau = 9$. Let $M = X(\cdot, 4 + 1/r) = N(-4, r)$ for some $r \in \mathbb{Q} \cup \{1/0\}$. Then

$$M(\pi) = X(\pi, r) = X\left(\frac{13}{2}, 4 + 1/r\right) = N\left(-4, r, -\frac{1}{2}\right) = N\left(-4, -\frac{1}{2}, r\right).$$

Since $M(\pi)$ contains a Klein bottle, $r = \frac{1}{2}(2n - 1)$ for some integer $n \neq 0$. See the last row of [ibid., Table 3]. If $n = -1$, then

$$\begin{aligned} M(\tau) &= X(\tau, 4 + 1/r) = X(9, 4 + 1/r) = N(-4, r, -3) \\ &= N(-3, -4, r) = N\left(-3, -4, -\frac{3}{2}\right) \end{aligned}$$

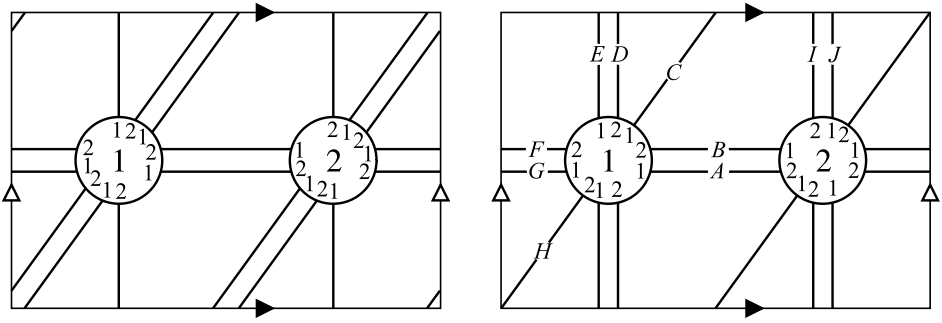

Figure 18. The graph G_T .

is not toroidal. See the last row for slope -3 in [ibid., Table 2]. We conclude that $M = N(-4, \frac{1}{2}(2n - 1))$ for some integer $n \neq 0, -1$.

Assume $\pi = 9$. Then $\tau = 13/2$. Let $M = X(\cdot, 4 + 1/r) = N(-4, r)$ for some $r \in \mathbb{Q} \cup \{1/0\}$. Then

$$\begin{aligned} M(\pi) &= X(\pi, 4 + 1/r) = X(9, 4 + 1/r) = N(-4, r, -3) \\ &= N(-4, -3, r) = N(-4, -\frac{1}{2}, -\frac{r+2}{r+1}). \end{aligned}$$

Since $M(\pi)$ contains a Klein bottle, $-\frac{r+2}{r+1} = \frac{1}{2}(2n - 1)$ for some integer $n \neq 0$. See the last row of [ibid., Table 3]. If $n = -1$, then

$$\begin{aligned} M(\tau) &= X(\tau, 4 + 1/r) = X(\frac{13}{2}, 4 + 1/r) = N(-4, r, -\frac{1}{2}) = N(-4, -\frac{1}{2}, r) \\ &= N(-4, -3, -\frac{r+2}{r+1}) = N(-4, -3, -\frac{3}{2}) = N(-3, -4, -\frac{3}{2}) \end{aligned}$$

is not toroidal. See the last row for slope -3 in [ibid., Table 2]. Hence $M = N(-4, r) = N(-4, -\frac{r+2}{r+1}) = N(-4, \frac{1}{2}(2n - 1))$ for some integer $n \neq 0, -1$. \square

8. The case $p \geq 2$ and $t = 2$

In this case, the argument in [Goda and Teragaito 2005, Section 9] shows the following.

- $p = 2$;
- nonloop edges of G_T are negative; and
- G_T is one of the graphs in Figure 18.

For the first graph in Figure 18, the argument in the second paragraph of the proof of [Teragaito 2006b, Lemma 7.4] shows that $M(\tau)$ contains a Klein bottle, contradicting our assumption. Hence G_T is the second graph in Figure 18. Then the graph G_P is uniquely determined as shown in Figure 19. See the third paragraph of the proof of [ibid., Lemma 7.4]. We obtain a graph pair G_S, G'_T from G_P and G_T

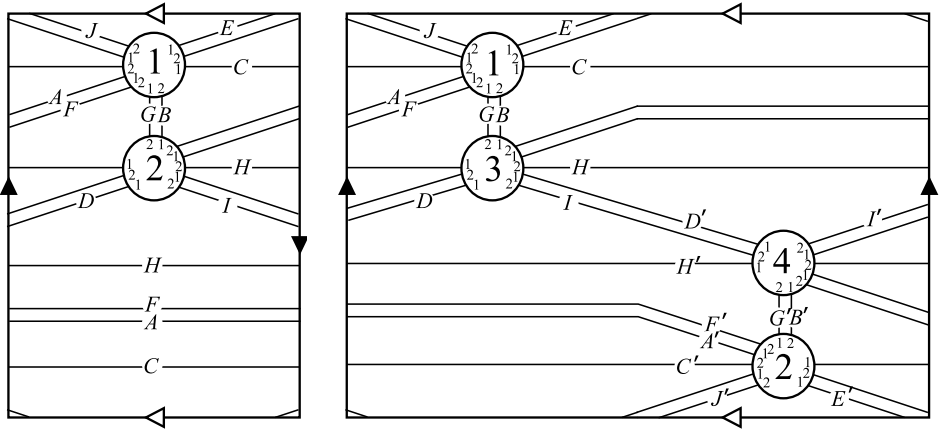

Figure 19. The graphs G_P and G_S .

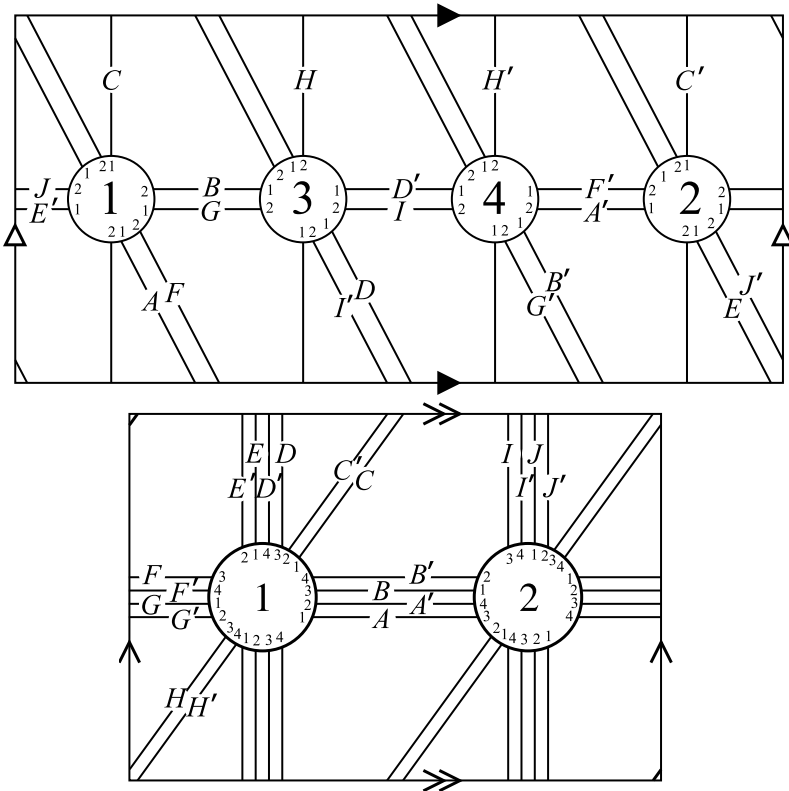

Figure 20. The graph pair G_S, G'_T .

as in Section 6. See Figure 19 for G_S . See Figure 20 for the edge correspondence between the graphs G_S and G'_T .

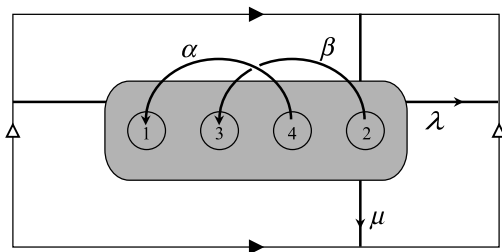

Figure 21. Generators for $\pi_1(Z)$.

Let $Z = M(\pi) - \text{Int } \eta(\hat{P})$, and let f, g , and h be the faces of G'_T bounded by the edges $A' \cup B, D' \cup E$ and $A \cup C' \cup D$, respectively. The group $\pi_1(Z)$ has four generators $\alpha, \beta, \lambda, \mu$ as shown in Figure 21, where α and β are represented by the cores of the two 1-handles V_{41}, V_{23} in $V_\pi \cap Z$. The three disks f, g , and h give three relations $\alpha\beta^{-1} = 1, \mu\lambda\beta\alpha = 1$, and $\alpha\mu\beta^{-1}\mu\beta\mu = 1$. Hence $\pi_1(Z)$ has the presentation

$$\langle \alpha, \beta, \lambda, \mu : \lambda\mu = \mu\lambda, \alpha\beta^{-1} = 1, \mu\lambda\beta\alpha = 1, \alpha\mu\beta^{-1}\mu\beta\mu = 1 \rangle.$$

Since $\alpha = \beta$ and $\lambda = \mu^{-1}\alpha^{-1}\beta^{-1} = \mu^{-1}\alpha^{-2}$, we have

$$\pi_1(Z) = \langle \alpha, \mu : \alpha^2\mu = \mu\alpha^2, \alpha\mu\alpha^{-1}\mu\alpha\mu = 1 \rangle.$$

Letting $\gamma = \mu\alpha$, one sees that $\pi_1(Z) = \langle \alpha, \gamma : \alpha^2 = \gamma^3 \rangle$, which implies that Z is not a solid torus. Hence \hat{S} is an essential torus and $M(\pi)$ is toroidal.

The graph pair G_S, G'_T is shown in [Gordon and Wu 2008, Figure 16.6]. By [ibid., Theorem 21.4], M is homeomorphic to M_7 in the notation of that paper. The double branched cover of the tangle on the top left in Figure 22 is M_7 (see [ibid., Lemma 22.2]). The figure shows that $M_7 = N(-5/3, -5/3)$.

Summarizing the results in this section, we obtain the following.

Lemma 8.1. *If $p \geq 2$ and $t = 2$, then $M(\pi)$ is toroidal and $M = N(-5/3, -5/3)$.*

References

[Eudave-Muñoz 2002] M. Eudave-Muñoz, “On hyperbolic knots with Seifert fibered Dehn surgeries”, *Topology Appl.* **121**:1-2 (2002), 119–141. MR 2003c:57005 Zbl 1009.57010

[Goda and Teragaito 2005] H. Goda and M. Teragaito, “On hyperbolic 3-manifolds realizing the maximal distance between toroidal Dehn fillings”, *Algebr. Geom. Topol.* **5** (2005), 463–507. MR 2006i:57009 Zbl 1082.57011

[Gompf and Stipsicz 1999] R. E. Gompf and A. I. Stipsicz, *4-manifolds and Kirby calculus*, Graduate Studies in Mathematics **20**, American Mathematical Society, Providence, RI, 1999. MR 2000h:57038 Zbl 0933.57020

[Gordon 1998] C. M. Gordon, “Boundary slopes of punctured tori in 3-manifolds”, *Trans. Amer. Math. Soc.* **350**:5 (1998), 1713–1790. MR 98h:57032 Zbl 0896.57011

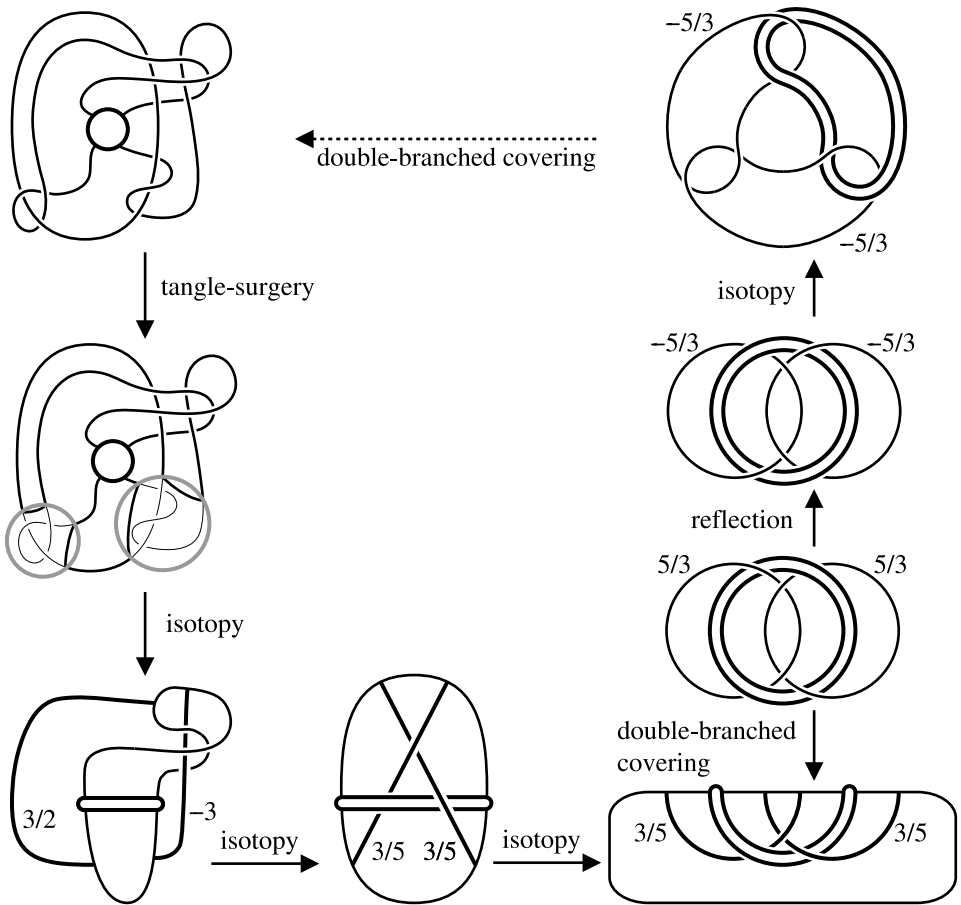

Figure 22. $N(-5/3, -5/3)$ is homeomorphic to M_7 .

[Gordon 1999] C. M. Gordon, “Toroidal Dehn surgeries on knots in lens spaces”, *Math. Proc. Cambridge Philos. Soc.* **125**:3 (1999), 433–440. [MR 99h:57006](#) [Zbl 0926.57014](#)

[Gordon and Luecke 1995] C. M. Gordon and J. Luecke, “Dehn surgeries on knots creating essential tori, I”, *Comm. Anal. Geom.* **3**:3-4 (1995), 597–644. [MR 96k:57003](#) [Zbl 0865.57015](#)

[Gordon and Wu 1999] C. M. Gordon and Y.-Q. Wu, “Toroidal and annular Dehn fillings”, *Proc. London Math. Soc.* (3) **78**:3 (1999), 662–700. [MR 2000b:57029](#) [Zbl 1024.57020](#)

[Gordon and Wu 2008] C. M. Gordon and Y.-Q. Wu, *Toroidal Dehn fillings on hyperbolic 3-manifolds*, Mem. Amer. Math. Soc. **909**, American Mathematical Society, Providence, RI, 2008. [MR 2009c:57036](#) [Zbl 1166.57014](#)

[Hayashi and Motegi 1997] C. Hayashi and K. Motegi, “Only single twists on unknots can produce composite knots”, *Trans. Amer. Math. Soc.* **349**:11 (1997), 4465–4479. [MR 98b:57010b](#) [Zbl 0883.57005](#)

[Jin et al. 2003] G. T. Jin, S. Lee, S. Oh, and M. Teragaito, “ P^2 -reducing and toroidal Dehn fillings”, *Math. Proc. Cambridge Philos. Soc.* **134**:2 (2003), 271–288. [MR 2004c:57035](#) [Zbl 1028.57011](#)

- [Lee 2006] S. Lee, “Dehn fillings yielding Klein bottles”, *Int. Math. Res. Not.* **2006** (2006), Art. ID 24253. [MR 2007b:57038](#) [Zbl 1106.57016](#)
- [Lee 2007] S. Lee, “Exceptional Dehn fillings on hyperbolic 3-manifolds with at least two boundary components”, *Topology* **46**:5 (2007), 437–468. [MR 2008h:57032](#) [Zbl 1123.57011](#)
- [Lee and Teragaito 2008] S. Lee and M. Teragaito, “Boundary structure of hyperbolic 3-manifolds admitting annular and toroidal fillings at large distance”, *Canad. J. Math.* **60**:1 (2008), 164–188. [MR 2009a:57029](#) [Zbl 1136.57007](#)
- [Martelli and Petronio 2006] B. Martelli and C. Petronio, “Dehn filling of the “magic” 3-manifold”, *Comm. Anal. Geom.* **14**:5 (2006), 969–1026. [MR 2007k:57042](#) [Zbl 1118.57018](#)
- [Oh 1997] S. Oh, “Reducible and toroidal 3-manifolds obtained by Dehn fillings”, *Topology Appl.* **75**:1 (1997), 93–104. [MR 98a:57027](#) [Zbl 0870.57008](#)
- [Teragaito 2000] M. Teragaito, “Toroidal Dehn fillings and lens spaces containing Klein bottles”, manuscript, 2000, available at <http://home.hiroshima-u.ac.jp/teragai/kb-tor.ps.gz>.
- [Teragaito 2006a] M. Teragaito, “Distance between toroidal surgeries on hyperbolic knots in the 3-sphere”, *Trans. Amer. Math. Soc.* **358**:3 (2006), 1051–1075. [MR 2006h:57005](#) [Zbl 1089.57007](#)
- [Teragaito 2006b] M. Teragaito, “Toroidal Dehn fillings on large hyperbolic 3-manifolds”, *Comm. Anal. Geom.* **14**:3 (2006), 565–601. [MR 2007f:57045](#)
- [Valdez-Sánchez 2007] L. G. Valdez-Sánchez, “Toroidal and Klein bottle boundary slopes”, *Topology Appl.* **154**:3 (2007), 584–603. [MR 2007j:57025](#) [Zbl 1113.57002](#)
- [Wu 1998] Y.-Q. Wu, “Dehn fillings producing reducible manifolds and toroidal manifolds”, *Topology* **37**:1 (1998), 95–108. [MR 98j:57033](#) [Zbl 0886.57012](#)

Received May 11, 2009.

SANGYOP LEE
DEPARTMENT OF MATHEMATICS
CHUNG-ANG UNIVERSITY
221 HEUKSEOK-DONG, DONGJAK-GU
SEOUL 156-756
SOUTH KOREA
sylee@cau.ac.kr

PACIFIC JOURNAL OF MATHEMATICS

<http://www.pjmath.org>

Founded in 1951 by

E. F. Beckenbach (1906–1982) and F. Wolf (1904–1989)

EDITORS

V. S. Varadarajan (Managing Editor)
Department of Mathematics
University of California
Los Angeles, CA 90095-1555
pacific@math.ucla.edu

Vyjayanthi Chari
Department of Mathematics
University of California
Riverside, CA 92521-0135
chari@math.ucr.edu

Robert Finn
Department of Mathematics
Stanford University
Stanford, CA 94305-2125
finn@math.stanford.edu

Kefeng Liu
Department of Mathematics
University of California
Los Angeles, CA 90095-1555
liu@math.ucla.edu

Darren Long
Department of Mathematics
University of California
Santa Barbara, CA 93106-3080
long@math.ucsb.edu

Jiang-Hua Lu
Department of Mathematics
The University of Hong Kong
Pokfulam Rd., Hong Kong
jhlu@maths.hku.hk

Alexander Merkurjev
Department of Mathematics
University of California
Los Angeles, CA 90095-1555
merkurev@math.ucla.edu

Sorin Popa
Department of Mathematics
University of California
Los Angeles, CA 90095-1555
popa@math.ucla.edu

Jie Qing
Department of Mathematics
University of California
Santa Cruz, CA 95064
qing@cats.ucsc.edu

Jonathan Rogawski
Department of Mathematics
University of California
Los Angeles, CA 90095-1555
jonr@math.ucla.edu

PRODUCTION

pacific@math.berkeley.edu

Silvio Levy, Scientific Editor

Mathew Cargo, Senior Production Editor

SUPPORTING INSTITUTIONS

ACADEMIA SINICA, TAIPEI
CALIFORNIA INST. OF TECHNOLOGY
INST. DE MATEMÁTICA PURA E APLICADA
KEIO UNIVERSITY
MATH. SCIENCES RESEARCH INSTITUTE
NEW MEXICO STATE UNIV.
OREGON STATE UNIV.

STANFORD UNIVERSITY
UNIV. OF BRITISH COLUMBIA
UNIV. OF CALIFORNIA, BERKELEY
UNIV. OF CALIFORNIA, DAVIS
UNIV. OF CALIFORNIA, LOS ANGELES
UNIV. OF CALIFORNIA, RIVERSIDE
UNIV. OF CALIFORNIA, SAN DIEGO
UNIV. OF CALIF., SANTA BARBARA

UNIV. OF CALIF., SANTA CRUZ
UNIV. OF MONTANA
UNIV. OF OREGON
UNIV. OF SOUTHERN CALIFORNIA
UNIV. OF UTAH
UNIV. OF WASHINGTON
WASHINGTON STATE UNIVERSITY

These supporting institutions contribute to the cost of publication of this Journal, but they are not owners or publishers and have no responsibility for its contents or policies.

See inside back cover or www.pjmath.org for submission instructions.

The subscription price for 2010 is US \$420/year for the electronic version, and \$485/year for print and electronic. Subscriptions, requests for back issues from the last three years and changes of subscribers address should be sent to Pacific Journal of Mathematics, P.O. Box 4163, Berkeley, CA 94704-0163, U.S.A. Prior back issues are obtainable from [Periodicals Service Company](#), 11 Main Street, Germantown, NY 12526-5635. The Pacific Journal of Mathematics is indexed by [Mathematical Reviews](#), [Zentralblatt MATH](#), [PASCAL CNRS Index](#), [Referativnyi Zhurnal](#), [Current Mathematical Publications](#) and the [Science Citation Index](#).

The Pacific Journal of Mathematics (ISSN 0030-8730) at the University of California, c/o Department of Mathematics, 969 Evans Hall, Berkeley, CA 94720-3840, is published monthly except July and August. Periodical rate postage paid at Berkeley, CA 94704, and additional mailing offices. POSTMASTER: send address changes to Pacific Journal of Mathematics, P.O. Box 4163, Berkeley, CA 94704-0163.

PJM peer review and production are managed by EditFLOW™ from Mathematical Sciences Publishers.

PUBLISHED BY PACIFIC JOURNAL OF MATHEMATICS

at the University of California, Berkeley 94720-3840

A NON-PROFIT CORPORATION

Typeset in L^AT_EX

Copyright ©2010 by Pacific Journal of Mathematics

PACIFIC JOURNAL OF MATHEMATICS

Volume 247 No. 2 October 2010

| | |
|--|-----|
| A family of representations of braid groups on surfaces | 257 |
| BYUNG HEE AN and KI HYOUNG KO | |
| Parametrization of holomorphic Segre-preserving maps | 283 |
| R. BLAIR ANGLE | |
| Chern classes on differential K -theory | 313 |
| ULRICH BUNKE | |
| Laplacian spectrum for the nilpotent Kac–Moody Lie algebras | 323 |
| DMITRY FUCHS and CONSTANCE WILMARTH | |
| Sigma theory and twisted conjugacy classes | 335 |
| DACIBERG GONÇALVES and DESSISLAVA HRISTOVA KOCHLOUKOVA | |
| Properties of annular capillary surfaces with equal contact angles | 353 |
| JAMES GORDON and DAVID SIEGEL | |
| Approximating annular capillary surfaces with equal contact angles | 371 |
| JAMES GORDON and DAVID SIEGEL | |
| Harmonic quasiconformal self-mappings and Möbius transformations of the unit ball | 389 |
| DAVID KALAJ and MIODRAG S. MATELJEVIĆ | |
| Klein bottle and toroidal Dehn fillings at distance 5 | 407 |
| SANGYOP LEE | |
| Representations of the two-fold central extension of $SL_2(\mathbb{Q}_2)$ | 435 |
| HUNG YEAN LOKE and GORDAN SAVIN | |
| Large quantum corrections in mirror symmetry for a 2-dimensional Lagrangian submanifold with an elliptic umbilic | 455 |
| GIOVANNI MARELLI | |
| Crossed pointed categories and their equivariantizations | 477 |
| DEEPAK NAIDU | |
| Painlevé analysis of generalized Zakharov equations | 497 |
| HASSAN A. ZEDAN and SALMA M. AL-TUWAIQI | |