

*Pacific  
Journal of  
Mathematics*

**PAINLEVÉ ANALYSIS OF GENERALIZED ZAKHAROV  
EQUATIONS**

HASSAN A. ZEDAN AND SALMA M. AL-TUWAIQI

## PAINLEVÉ ANALYSIS OF GENERALIZED ZAKHAROV EQUATIONS

HASSAN A. ZEDAN AND SALMA M. AL-TUWAIQI

**We consider the invariance and integrability properties of the generalized Zakharov equations and obtain an exact invariant solution. We derive the Painlevé property of these equations and obtain some exact solutions using the truncated Painlevé expansion.**

### 1. Introduction

We consider the generalized Zakharov equations (GZEs) for the complex envelope  $E(x, t)$  of the high-frequency wave and the real low-frequency field  $\eta(x, t)$  in the form

$$(1) \quad iE_t + E_{xx} - 2\beta|E|^2E + 2E\eta = 0,$$

$$(2) \quad \eta_{tt} - \eta_{xx} = -(|E|^2)_{xx},$$

where the cubic term in Equation (1) describes nonlinear self-interaction in the high-frequency subsystem; such a term corresponds to a self-focusing effect in plasma physics. The coefficient  $\beta$  is a real constant that can be positive or negative. The sound velocity and the coupling constant in Equation (2) have been normalized to unity for simplicity. The GZEs are a universal model of interaction between high- and low-frequency waves in one dimension. The collisions between solitary waves of GZEs have been simulated in detail in [Hadouaj et al. 1991]. When  $\beta = 0$ , this system is reduced to the classical Zakharov equations for plasma physics.

Several aspects of the GZEs have been studied. Malomed, Anderson, Lisak, Quiroga-Teixeiro and Stenflo [1997] analyzed them using a variational approach. Wang and Li [2005] introduced periodic wave solutions using the extended  $F$ -expansion method. By considering the modified Adomian decomposition method, Wang, Dai, Wu, Lei and Zhang [2007] calculated exact and numerical solutions. Zhang [2007] constructed exact traveling wave solutions by a direct algebraic method. Li, Li and Lin [2008] used the exp-function method to obtain exact solutions. Javidi and Golbabi [2008] obtained exact and numerical solutions by the

---

*MSC2000:* primary 35Q51; secondary 35K05.

*Keywords:* generalized Zakharov equations, Lie symmetries, Painlevé expansion.

variational iteration method. Abbasbandy, Babolian and Ashtiani [2009] applied homotopy analysis method to obtain a solution.

The objective of this work is to investigate the symmetry and conduct Painlevé analysis of GZEs. It will be organized as follows. In Section 2, we obtain the Lie point symmetry group of GZEs and its similarity reductions. Moreover, we also construct explicit analytic invariant solutions. In Section 3, we inspect the singularity structure of GZEs by means of the Weiss–Tabor–Carnevale procedure. In Section 4, we obtain some exact solutions using the truncated Painlevé expansion.

## 2. Symmetry analysis

Symmetry is one of the most important concepts in the area of partial differential equations [Bluman and Kumei 1989]. To find the Lie symmetries of the GZEs, we express the complex envelope as  $E(x, t) = u(x, t) + iv(x, t)$ , with real high-frequency waves  $u(x, t)$  and  $v(x, t)$ . Substituting it into Equations (1) and (2) and separating the imaginary and real parts we obtain the equations

$$(3) \quad \begin{aligned} u_{xx} - v_t - 2\beta(u^2 + v^2)u + 2\eta u &= 0, \\ u_t + v_{xx} - 2\beta(u^2 + v^2)v + 2\eta v &= 0, \\ \eta_{tt} - \eta_{xx} &= -(u^2 + v^2)_{xx}. \end{aligned}$$

Consider a one-parameter Lie group of infinitesimal transformations of the form

$$(4) \quad \begin{aligned} u &\rightarrow U = u + \varepsilon\phi_1(x, t, u, v, \eta), \\ v &\rightarrow V = v + \varepsilon\phi_2(x, t, u, v, \eta), \\ \eta &\rightarrow \Lambda = \eta + \varepsilon\phi_3(x, t, u, v, \eta), \\ x &\rightarrow X = x + \varepsilon\xi_1(x, t, u, v, \eta), \\ t &\rightarrow T = t + \varepsilon\xi_2(x, t, u, v, \eta) \quad \text{for } \varepsilon \ll 1, \end{aligned}$$

with infinitesimal generator

$$(5) \quad \tilde{X} = \xi_1 \frac{\partial}{\partial x} + \xi_2 \frac{\partial}{\partial t} + \phi_1 \frac{\partial}{\partial u} + \phi_2 \frac{\partial}{\partial v} + \phi_3 \frac{\partial}{\partial \eta}.$$

Require that (3) are invariant under (4) by direct substitution [Bluman and Kumei 1989]. Eliminate  $u_t, v_t, \eta_{tt}$  using (3), and set to zero all coefficients of the independent terms of the polynomials of  $u, v$  and  $\eta$  and their partial derivatives. We then obtain the determining equations for the infinitesimals. By solving these equations

we have

$$\begin{aligned} \phi_1 &= -(k_3 + k_4t + k_5t^2)v, \\ \phi_2 &= (k_3 + k_4t + k_5t^2)u, \\ \phi_3 &= \frac{1}{2}k_4 + k_5t, \\ \zeta_1 &= k_1, \quad \zeta_2 = k_2, \end{aligned}$$

where  $k_1, k_2, k_3, k_4$  and  $k_5$  are arbitrary parameters. The infinitesimal generator of the Lie algebra associated with each parameter  $k_i$  is obtained from the generator (5):

$$\begin{aligned} L_1 &= \frac{\partial}{\partial x}, \quad L_2 = \frac{\partial}{\partial t}, \quad L_4 = tu \frac{\partial}{\partial v} - tv \frac{\partial}{\partial u} + \frac{1}{2} \frac{\partial}{\partial \eta}, \\ L_3 &= u \frac{\partial}{\partial v} - v \frac{\partial}{\partial u}, \quad L_5 = t^2u \frac{\partial}{\partial v} - t^2v \frac{\partial}{\partial u} + t \frac{\partial}{\partial \eta}. \end{aligned}$$

The similarity solution can be obtained from the invariant surface equation

$$\frac{dt}{k_2} = \frac{dx}{k_1} = \frac{du}{-(k_3 + k_4t + k_5t^2)v} = \frac{dv}{(k_3 + k_4t + k_5t^2)u} = \frac{d\eta}{k_4/2 + k_5t}.$$

For the most general generator  $X$ , we obtain the similarity solution

$$\begin{aligned} u(x, t) &= c \cos\left(\frac{k_5}{3k_2}t^3 + \frac{k_4}{2k_2}t^2 + \frac{k_3}{k_2}t + F_1(z)\right), \\ v(x, t) &= c \sin\left(\frac{k_5}{3k_2}t^3 + \frac{k_4}{2k_2}t^2 + \frac{k_3}{k_2}t + F_1(z)\right), \\ \eta(x, t) &= \frac{k_5}{2k_2}t^2 + \frac{k_4}{2k_2}t + F_2(z), \end{aligned}$$

where  $F_1$  and  $F_2$  are similarity functions of the similarity variable  $z = k_1t - k_2x$ , satisfying the similarity equations

$$\begin{aligned} 0 &= -k_2^3(F_1'' - (F_1')^2) + k_1k_2F_1' - 2k_2F_2 + k_3 + 2c^2\beta k_2, \\ (6) \quad 0 &= k_2^3(F_1'' + (F_1')^2) + k_1k_2F_1' - 2k_2F_2 + k_3 + 2c^2\beta k_2, \\ 0 &= F_2'' + k_5/(k_2(k_1^2 - k_2^2)), \end{aligned}$$

where prime denotes differentiation with respect to  $z$ . Solving equations (6), we obtain the solution

$$\begin{aligned} F_1 &= \frac{1}{2k_2^3}(-k_1k_2 + \sqrt{(k_1k_2)^2 - 4k_2^3(k_3 - 2k_2(a_2 - c^2\beta))})z + a_0, \\ F_2 &= a_1, \end{aligned}$$

where  $a_0$  and  $a_1$  are arbitrary constants. Hence the exact invariant solution to

GZEs (1) and (2) can be written as

$$E(x, t) = c \exp\left(\frac{i}{2k_2^3} (k_2^2 (\frac{2}{3}k_5t^3 + k_4t^2 + 2k_3t) + (k_1t - k_2x) \sqrt{(k_1k_2)^2 - 4k_2^3(k_3 - 2k_2(a_1 - c^2\beta)) - k_1k_2 + 2k_2^3a_0})\right),$$

$$\eta(x, t) = \frac{k_5}{2k_2}t^2 + \frac{k_4}{2k_2}t + a_1.$$

### 3. Painlevé analysis

The Painlevé test is one of the impressive ways to test whether partial differential equations are integrable or nonintegrable. Myrzakulov [1999] has confirmed the Painlevé nature of the (2+1)-dimensional Zakharov equation. In this paper we will show that GZEs possess the Painlevé property. Various approaches can be applied to investigate the Painlevé integrability. Here we will use WTC method [Weiss et al. 1983]. Consider Laurent expansion of the solutions of (3) in a local neighborhood of a movable singular manifold  $\phi(x, t) = 0$ :

$$u(x, t) = \sum_{j=0}^{\infty} u_j \phi^{j+\alpha_1}, \quad v(x, t) = \sum_{j=0}^{\infty} v_j \phi^{j+\alpha_2}, \quad \eta(x, t) = \sum_{j=0}^{\infty} \eta_j \phi^{j+\alpha_3},$$

where  $u_j(x, t)$ ,  $v_j(x, t)$  and  $\eta_j(x, t)$  are analytic functions and the three  $\alpha_i$  are integers to be determined. It is sufficient to substitute

$$u(x, t) = u_0 \phi^{\alpha_1}, \quad v(x, t) = v_0 \phi^{\alpha_2}, \quad \eta(x, t) = \eta_0 \phi^{\alpha_3},$$

into equations (3) to find the dominant behavior and leading exponents  $\alpha_i$ . Balancing the dominant terms, we get  $\alpha_1 = \alpha_2 = -1$  and  $\alpha_3 = -2$ , and the equations

$$u_0^2 + v_0^2 = \phi_x^2 - \frac{\phi_x^4}{\beta^2 \phi_t^2 + \beta(1-\beta)\phi_x^2} \quad \text{and} \quad \eta_0 = -\frac{\phi_x^4}{\beta^2 \phi_t^2 + (1-\beta)\phi_x^2}.$$

The first shows that either  $u_0$  or  $v_0$  is arbitrary. Substituting the series expansion

$$u = u_0 \phi^{-1} + u_r \phi^{r-1}, \quad v = v_0 \phi^{-1} + v_r \phi^{r-1}, \quad \eta = \eta_0 \phi^{-2} + \eta_r \phi^{r-2},$$

into equations (3) and collecting the coefficients of  $u_r$ ,  $v_r$  and  $\eta_r$  for leading terms, the resonance are found to have the values  $r = -1, 0, 2, 3, 4$ . As usual, the resonance  $r = -1$  represents the arbitrariness of the singularity manifold  $\phi(x, t) = 0$ , and the remaining resonance values indicate the arbitrariness of five functions (one of  $\{u_0, v_0, \eta_0\}$ , one of  $\{u_2, v_2, \eta_2\}$ , two of  $\{u_3, v_3, \eta_3\}$  and one of  $\{u_4, v_4, \eta_4\}$ ).

#### 4. Some solutions to the generalized Zakharov equation

When an equation has the Painlevé property, one can find some kinds of exact solutions by truncating the Painlevé expansion of the solution about the movable singularity manifold at the constant level term, leading to the so-called Backlund transformation of the equation. For GZEs, the transformation has the form

$$(7) \quad u = u_0\phi^{-1} + u_1, \quad v = v_0\phi^{-1} + v_1, \quad \eta = \eta_0\phi^{-2} + \eta_1\phi^{-1} + \eta_2.$$

Our approach to finding an exact solution for  $u$ ,  $v$  and  $\eta$  is similar to that of [Choudhury 2006]. Substituting equations (7) into equations (3) and equating the coefficients of  $\phi^{-i}$  for  $i = 0, 1, 2, 3, 4$  to zero, we obtain this system of PDEs:

$$(8) \quad 0 = -2\beta u_1^2 v_1 - 2\beta v_1^3 + 2v_1 \eta_2 + u_{1,t} + v_{1,xx},$$

$$(9) \quad 0 = -2\beta u_1^2 v_0 - 4\beta u_0 u_1 v_1 - 6\beta v_0 v_1^2 + 2v_1 \eta_1 + 2v_0 \eta_2 + u_{0,t} + v_{0,xx},$$

$$(10) \quad 0 = -4\beta u_0 u_1 v_0 - 2\beta u_0^2 v_1 - 6\beta v_0^2 v_1 + 2v_1 \eta_0 + 2v_0 \eta_1 - u_0 \phi_t - 2v_{0,x} \phi_x - v_0 \phi_{xx},$$

$$(11) \quad 0 = -2\beta u_0^2 v_0 - 2\beta v_0^3 + 2v_0 \eta_0 + 2v_0 \phi_x^2,$$

$$(12) \quad 0 = -2\beta u_1^3 - 2\beta u_1 v_1^2 + 2u_1 \eta_2 - v_{1,t} + u_{1,xx},$$

$$(13) \quad 0 = -6\beta u_0 u_1^2 - 4\beta u_1 v_0 v_1 - 2\beta u_0 v_1^2 + 2u_1 \eta_1 + 2u_0 \eta_2 - v_{0,t} + u_{0,xx},$$

$$(14) \quad 0 = -6\beta u_0^2 u_1 - 2\beta u_1 v_0^2 - 4\beta u_0 v_0 v_1 + 2u_1 \eta_0 + 2u_0 \eta_1 + v_0 \phi_t - 2u_{0,x} \phi_x - u_0 \phi_{xx},$$

$$(15) \quad 0 = -2\beta u_0^3 - 2\beta u_0 v_0^2 + 2u_0 \eta_0 + 2u_0 \phi_x^2,$$

$$(16) \quad 0 = \eta_{2,tt} + 2u_{1,x}^2 + 2v_{1,x}^2 + 2u_1 u_{1,xx} + 2v_1 v_{1,xx} - \eta_{2,xx},$$

$$(17) \quad 0 = \eta_{1,tt} + 4u_{0,x} u_{1,x} + 4v_{0,x} v_{1,x} + 2u_1 u_{0,xx} + 2u_0 u_{1,xx} \\ + 2v_1 v_{0,xx} + 2v_0 v_{1,xx} - \eta_{1,xx},$$

$$(18) \quad 0 = -2\eta_{1,t} \phi_t - \eta_1 \phi_{tt} + \eta_{0,tt} - 4u_1 \phi_x u_{0,x} + 2u_{0,x}^2 - 4u_0 \phi_x u_{1,x} \\ - 4v_1 \phi_x v_{0,x} + 2v_{0,x}^2 - 4v_0 \phi_x v_{1,x} + 2\phi_x \eta_{1,x} - 2u_0 u_1 \phi_{xx} \\ - 2v_0 v_1 \phi_{xx} + \eta_1 \phi_{xx} + 2u_0 u_{0,xx} + 2v_0 v_{0,xx} - \eta_{0,xx},$$

$$(19) \quad 0 = 2\eta_1 \phi_t^2 - 4\phi_t \eta_{0,t} - 2\eta_0 \phi_{tt} + 4u_0 u_1 \phi_x^2 + 4v_0 v_1 \phi_x^2 - 2\eta_1 \phi_x^2 \\ - 8u_0 \phi_x u_{0,x} - 8v_0 \phi_x v_{0,x} + 4\phi_x \eta_{0,x} - 2u_0^2 \phi_{xx} - 2v_0^2 \phi_{xx} + 2\eta_0 \phi_{xx},$$

$$(20) \quad 0 = 6\eta_0 \phi_t^2 + 6u_0^2 \phi_x^2 + 6v_0^2 \phi_x^2 - 6\eta_0 \phi_x^2.$$

Substituting a trial solution  $\phi(x, t) = 1 + \exp(iQ(x, t))$  into system (8)–(20), we consider two cases:

*Case 1.* Let  $v_0(x, t) = \exp(iQ(x, t))$  be the arbitrary function; then equation (11), (15) and (10) become

$$(21) \quad 0 = -2e^{iQ}(e^{2iQ}(\beta + Q_x^2) + \beta u_0^2 - \eta_0),$$

$$(22) \quad 0 = -2u_0(e^{2iQ}(\beta + Q_x^2) + \beta u_0^2 - \eta_0),$$

$$(23) \quad 0 = -2\beta u_0^2 v_1 + v_1(-6\beta e^{2iQ} + 2\eta_0) + 2e^{iQ} \eta_1 \\ - e^{iQ} u_0(4\beta u_1 + iQ_t) + 3e^{2iQ} Q_x^2 - ie^{2iQ} Q_{xx}.$$

It is convenient to separate (23) into two equations:

$$\begin{aligned} 0 &= -e^{iQ} u_0 (i Q_t) - i e^{2iQ} Q_{xx}, \\ 0 &= -2\beta u_0^2 v_1 + v_1 (-6\beta e^{2iQ} + 2\eta_0) + 2e^{iQ} \eta_1 - 4\beta e^{iQ} u_0 u_1 + 3e^{2iQ} Q_x^2. \end{aligned}$$

Solving the first for  $u_0$  we get  $u_0(x, t) = -Q_{xx} e^{iQ} / Q_t$ . Substituting this into (21) we obtain

$$\eta_0(x, t) = (\beta Q_t^2 + Q_t^2 Q_x^2 + \beta Q_{xx}^2) e^{2iQ} / Q_t^2.$$

Letting  $Q(x, t) = f_1(t)x + f_2(t)$  and substituting this into system (8)–(20), we find that (20) has the form

$$\begin{aligned} 0 &= 6e^{4i(f_1x+f_2)} (f_1^4 - \beta(xf_1' + f_2')^2 + f_1^2(-1 + \beta - x^2 f_1'^2 - 2xf_1'f_2' - f_2'^2)), \\ 0 &= f_1^4 - \beta(xf_1' + f_2')^2 + f_1^2(-1 + \beta - x^2 f_1'^2 - 2xf_1'f_2' - f_2'^2). \end{aligned}$$

Equating the coefficients of  $x^2$ ,  $x^1$  and  $x^0$  in the second equation to zero, we obtain

$$\begin{aligned} 0 &= -f_1^2 + \beta f_1^2 + f_1^4 - \beta f_2'^2 - f_1^2 f_2'^2, \\ 0 &= -2\beta f_1' f_2' - 2f_1^2 f_1' f_2', \\ 0 &= -f_1'^2 (\beta + f_1^2). \end{aligned}$$

The first two are satisfied if  $f_1(t) = c_1$ . Substituting this into the last and solving for  $f_2$ , we get

$$f_2(t) = \sqrt{\frac{-c_1^2(c_1^2 + \beta - 1)}{-\beta - c_1^2}} t + c_2.$$

Substituting all the above results into equations (10), (13) and (14) and solving for  $v_1$ ,  $u_1$  and  $\eta_1$  we find  $v_1(x, t) = -1/2$ ,

$$u_1(x, t) = \frac{i\sqrt{(\beta + c_1^2)(\beta + c_1^2 - 1)}}{2c_1(\beta + c_1^2)} \quad \text{and} \quad \eta_1(x, t) = -(\beta + c_1^2) \exp(ih(x, t)),$$

where  $h(x, t) = c_1x + c_2 + \sqrt{c_1^2(1 - \beta - c_1^2)}t / \sqrt{-\beta - c_1^2}$ . Solving (8) or (9) or (12) for  $\eta_2$ , we get

$$\eta_2(x, t) = \frac{\beta(1 - c_1^2 + c_1^4) - \beta^2(1 - c_1^2)}{4c_1^2(\beta + c_1^2)},$$

Substituting all the results into the truncated expansion (7), we obtain the corresponding exact solution of GZEs (3):

$$\begin{aligned} u(x, t) &= -\frac{i\sqrt{1 - \beta - c_1^2}}{2c_1\sqrt{-\beta - c_1^2}}, \quad v(x, t) = -\frac{1}{2} + \frac{\exp(ih(x, t))}{1 + \exp(ih(x, t))}, \\ \eta(x, t) &= \frac{\beta(1 - c_1^2 + c_1^4) - \beta^2(1 - c_1^2)}{4c_1^2(\beta + c_1^2)} \\ &\quad + \frac{(\beta + c_1^2) \exp(ih(x, t))}{1 + \exp(ih(x, t))} \left( \frac{\exp(ih(x, t))}{1 + \exp(ih(x, t))} - 1 \right). \end{aligned}$$

Figures 1, 2, 3, 4 and 5 illustrate the solution for certain  $\beta$ ,  $c_1$  and  $c_2$ .

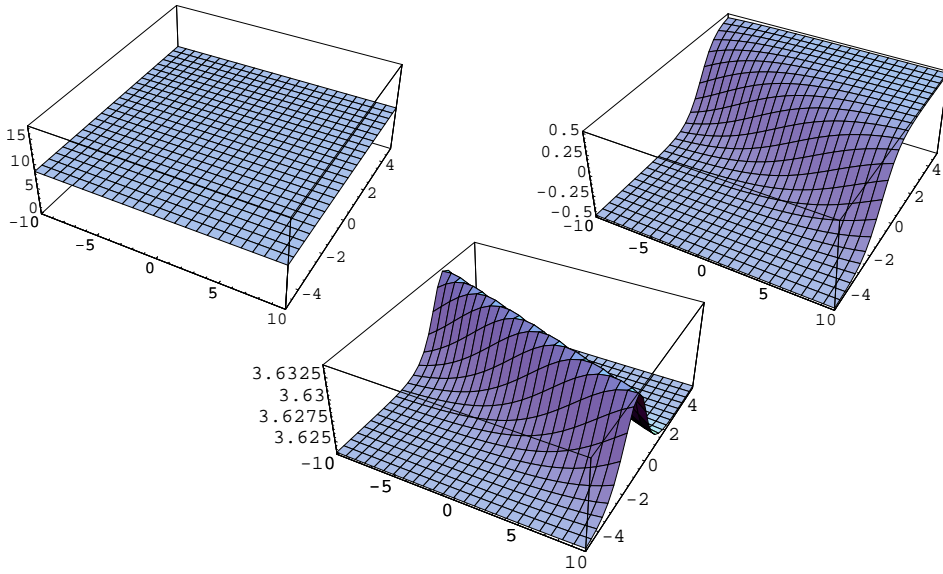

**Figure 1.** Clockwise from top left: Graphs of  $u(x, t)$ ,  $v(x, t)$  and  $\eta(x, t)$  for  $\beta = 0.05$ ,  $c_1 = -0.3i$  and  $c_2 = i$ .

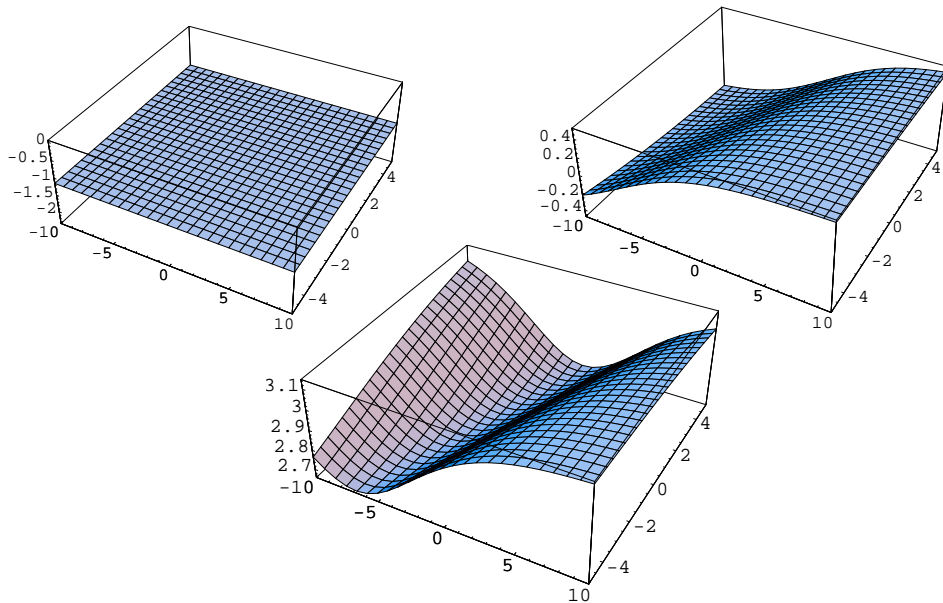

**Figure 2.** Clockwise from top left: Graphs of  $u(x, t)$ ,  $v(x, t)$  and  $\eta(x, t)$  for  $\beta = 2$ ,  $c_1 = -0.3i$  and  $c_2 = -i$ .

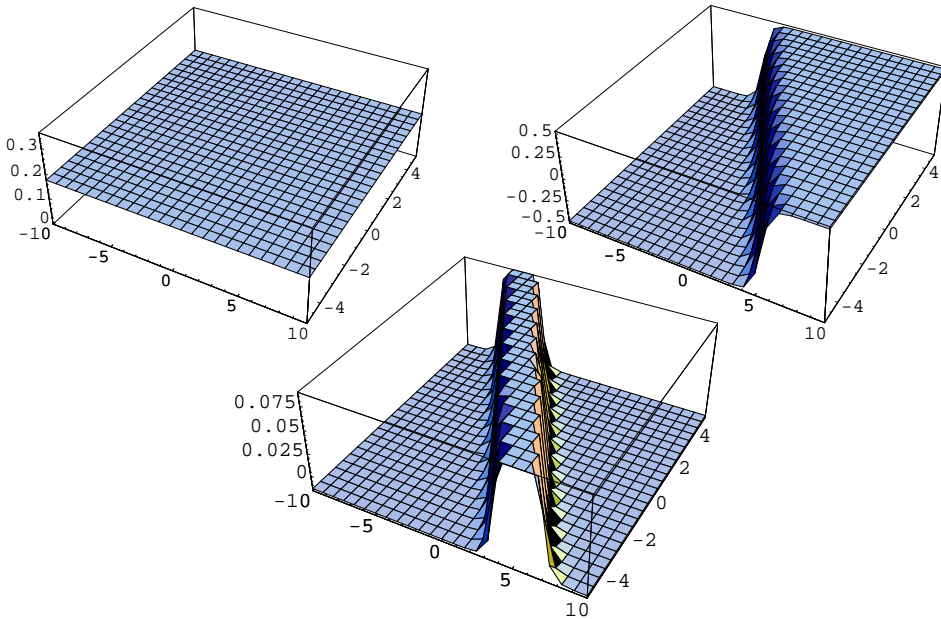

**Figure 3.** Clockwise from top left: Graphs of  $u(x, t)$ ,  $v(x, t)$  and  $\eta(x, t)$  for  $\beta = -0.05$ ,  $c_1 = -3i$  and  $c_2 = 0.4i$ .

Case 2: Let

$$u_0(x, t) = \exp(i Q(x, t))$$

be the arbitrary function. Then separate (14) into two equations:

$$\begin{aligned} 0 &= i v_0 Q_t - i e^{i Q} Q_{xx}, \\ 0 &= -2u_1(3\beta e^{2i Q} + \beta v_0^2 - \eta_0) + e^{i Q}(2\eta_1 + v_0(-4\beta v_1 + i Q_t) + 3e^{i Q} Q_x^2). \end{aligned}$$

From the first we obtain  $v_0(x, t) = Q_{xx} e^{i Q} / Q_t$ . Solving (11) for  $\eta_0$ , we get

$$\eta_0(x, t) = (\beta Q_t^2 + Q_t^2 Q_x^2 + \beta Q_{xx}^2) e^{2i Q} / Q_t^2.$$

Letting  $Q(x, t) = f_1(t)x + f_2(t)$  and substituting this into system (8)–(20), we find that (20) assumes the form

$$\begin{aligned} 0 &= 6e^{4i(f_1x+f_2)}(f_1^4 - \beta(xf_1' + f_2')^2 + f_1^2(-1 + \beta - x^2 f_1'^2 - 2xf_1'f_2' - f_2'^2)), \\ 0 &= f_1^4 - \beta(xf_1' + f_2')^2 + f_1^2(-1 + \beta - x^2 f_1'^2 - 2xf_1'f_2' - f_2'^2). \end{aligned}$$

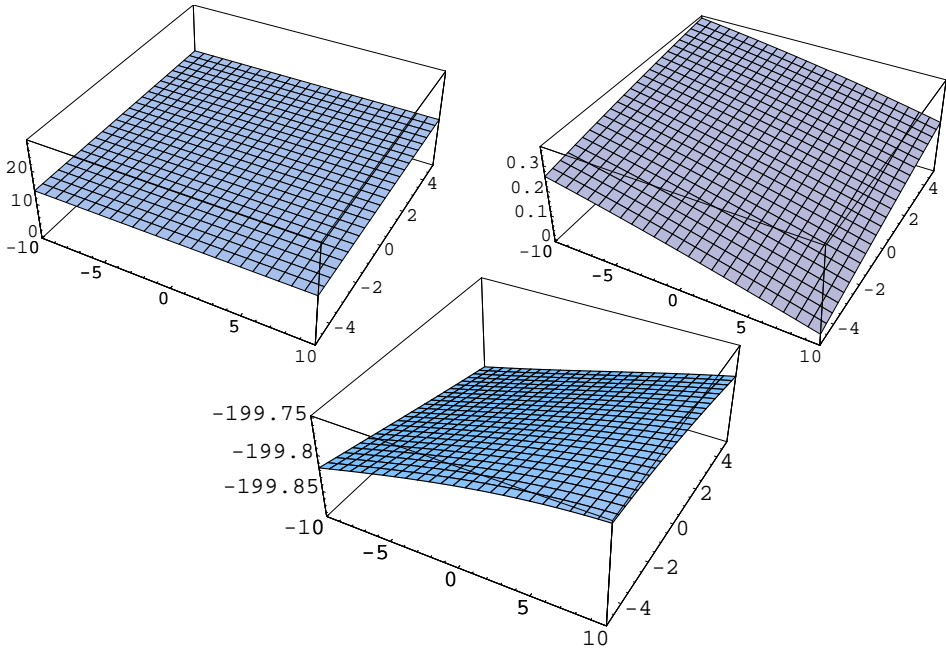

**Figure 4.** Clockwise from top left: Graphs of  $u(x, t)$ ,  $v(x, t)$  and  $\eta(x, t)$  for  $\beta = -1$ ,  $c_1 = 0.05i$  and  $c_2 = -i$ .

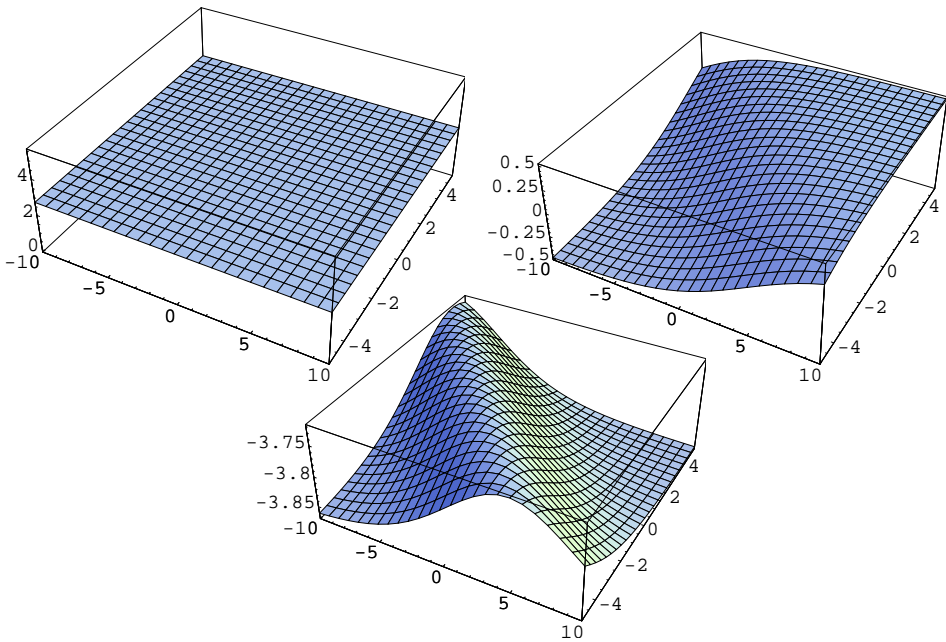

**Figure 5.** Clockwise from top left: Graphs of  $u(x, t)$ ,  $v(x, t)$  and  $\eta(x, t)$  for  $\beta = -0.5$ ,  $c_1 = -0.3$  and  $c_2 = -i$ .

Equating the coefficients of  $x^2$ ,  $x^1$  and  $x^0$  in the second of these to zero, we obtain

$$\begin{aligned} 0 &= -f_1^2 + \beta f_1^2 + f_1^4 - \beta f_2^2 - f_1^2 f_2^2, \\ 0 &= -2\beta f_1' f_2' - 2f_1^2 f_1' f_2', \\ 0 &= -f_1'^2 (\beta + f_1^2). \end{aligned}$$

The latter two are satisfied if  $f_1(t) = c_1$ . Substituting this into the first equation above and solving for  $f_2$ , we get

$$f_2(t) = t \sqrt{\frac{-c_1^2(c_1^2 + \beta - 1)}{-\beta - c_1^2}} + c_2.$$

Substituting all the above results into Equations (10), (14) and (19) and solving for  $v_1$ ,  $u_1$  and  $\eta_1$  we find

$$\begin{aligned} u_1(x, t) &= -1/2, \\ v_1(x, t) &= \frac{i\sqrt{(-\beta - c_1^2 + 1)}}{2c_1(\beta + c_1^2)}, \\ \eta_1(x, t) &= -(\beta + c_1^2) \exp(ih(x, t)), \end{aligned}$$

where  $h(x, t) = c_1x + c_2 + t\sqrt{c_1^2(1 - \beta - c_1^2)}/\sqrt{-\beta - c_1^2}$ . Solving (8) or (12) or (13) for  $\eta_2$ , we get

$$\eta_2(x, t) = \frac{\beta(1 - c_1^2 + c_1^4) - \beta^2(1 - c_1^2)}{4c_1^2(\beta + c_1^2)},$$

Substituting all the results into the truncated expansion (7), we obtain the corresponding exact solution of GZEs (3):

$$\begin{aligned} v(x, t) &= \frac{i\sqrt{1 - \beta - c_1^2}}{2c_1\sqrt{-\beta - c_1^2}} \\ u(x, t) &= -\frac{1}{2} + \frac{\exp(ih(x, t))}{1 + \exp(ih(x, t))} \\ \eta(x, t) &= \frac{\beta(1 - c_1^2 + c_1^4) - \beta^2(1 - c_1^2)}{4c_1^2(\beta + c_1^2)} \\ &\quad + \frac{(\beta + c_1^2) \exp(ih(x, t))}{1 + \exp(ih(x, t))} \left( \frac{\exp(ih(x, t))}{1 + \exp(ih(x, t))} - 1 \right). \end{aligned}$$

Figures 6, 7, 8, 9 and 10 illustrate the solution for certain  $\beta$ ,  $c_1$  and  $c_2$ .

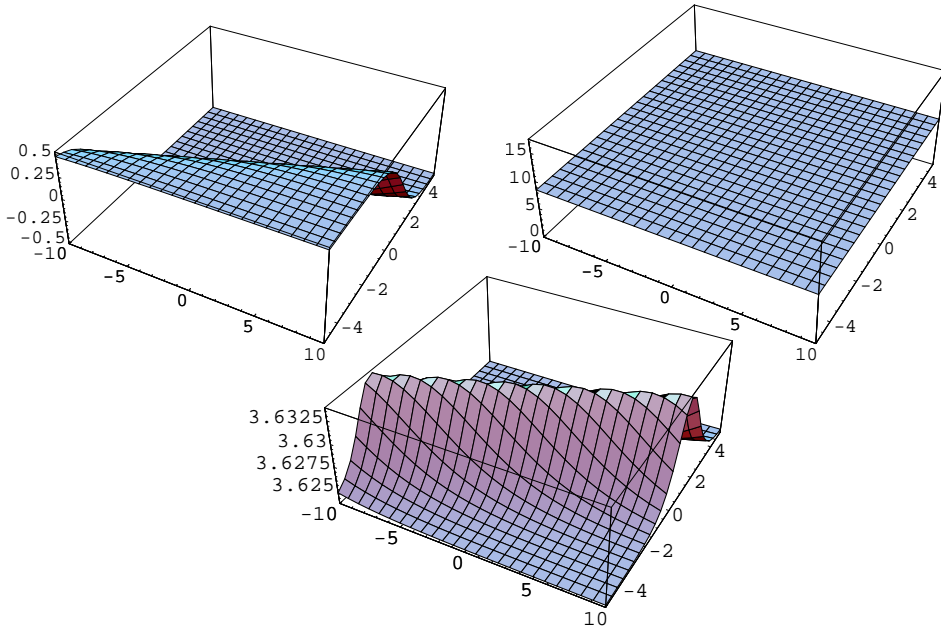

**Figure 6.** Clockwise from top left: Graphs of  $u(x, t)$ ,  $v(x, t)$  and  $\eta(x, t)$  for  $\beta = 0.05$ ,  $c_1 = -0.3i$  and  $c_2 = i$ .

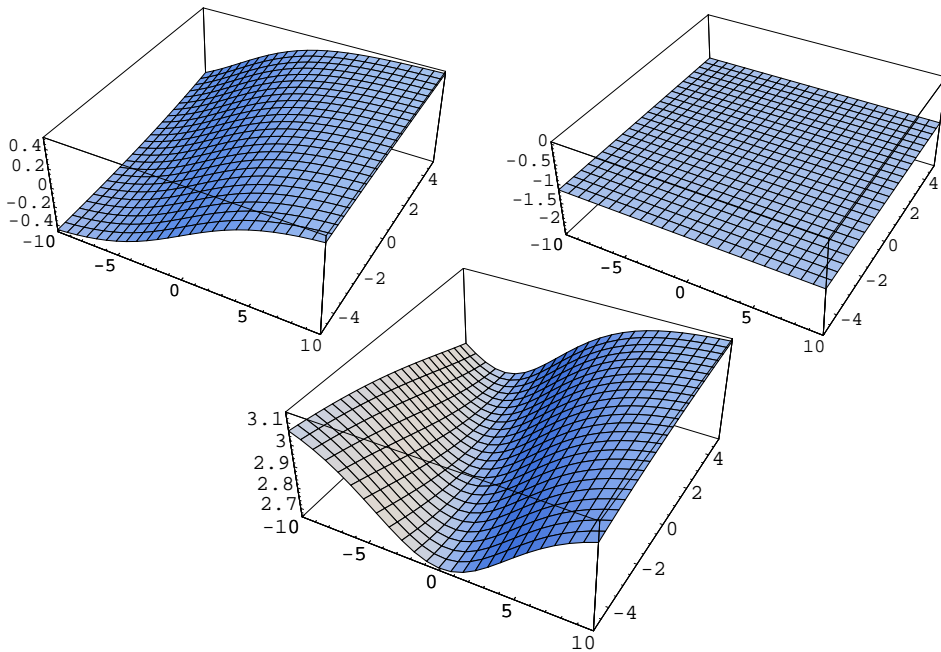

**Figure 7.** Clockwise from top left: Graphs of  $u(x, t)$ ,  $v(x, t)$  and  $\eta(x, t)$  for  $\beta = 2$ ,  $c_1 = -0.3i$  and  $c_2 = -i$ .

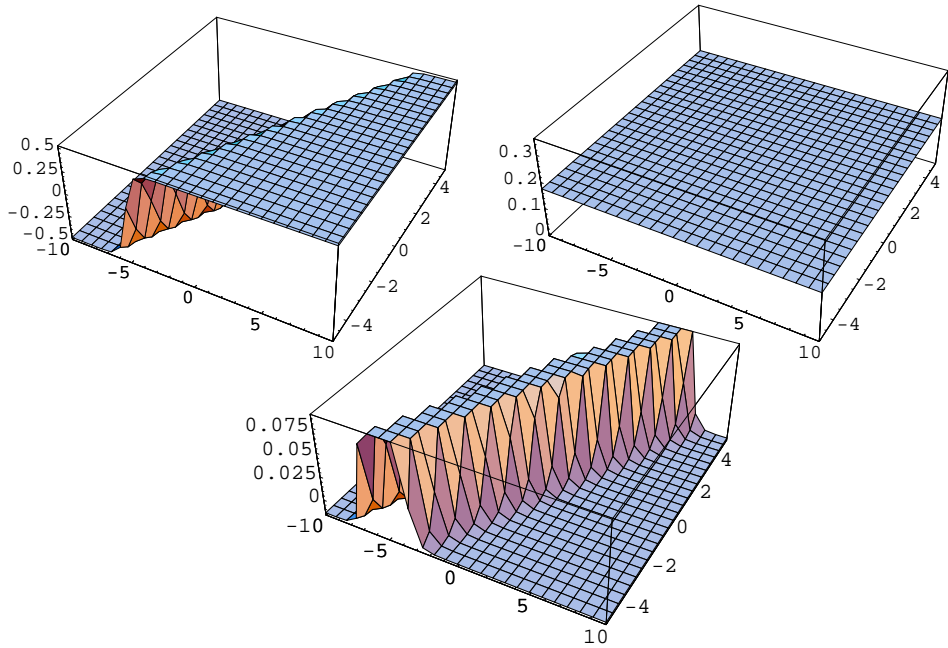

**Figure 8.** Clockwise from top left: Graphs of  $u(x, t)$ ,  $v(x, t)$  and  $\eta(x, t)$  for  $\beta = -0.05$ ,  $c_1 = -3i$  and  $c_2 = 0.4i$ .

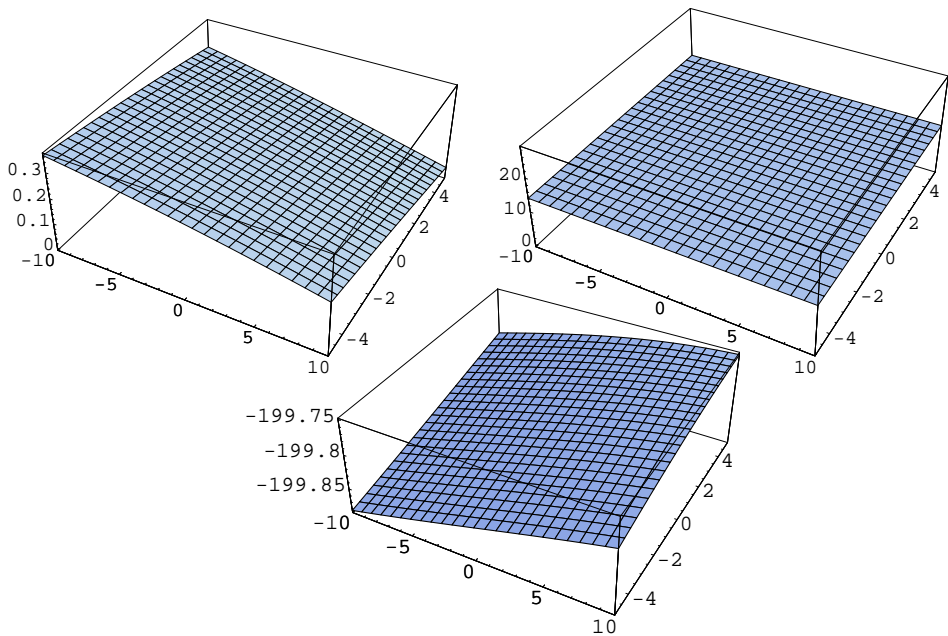

**Figure 9.** Clockwise from top left: Graphs of  $u(x, t)$ ,  $v(x, t)$  and  $\eta(x, t)$  for  $\beta = -1$ ,  $c_1 = 0.05$  and  $c_2 = -i$ .

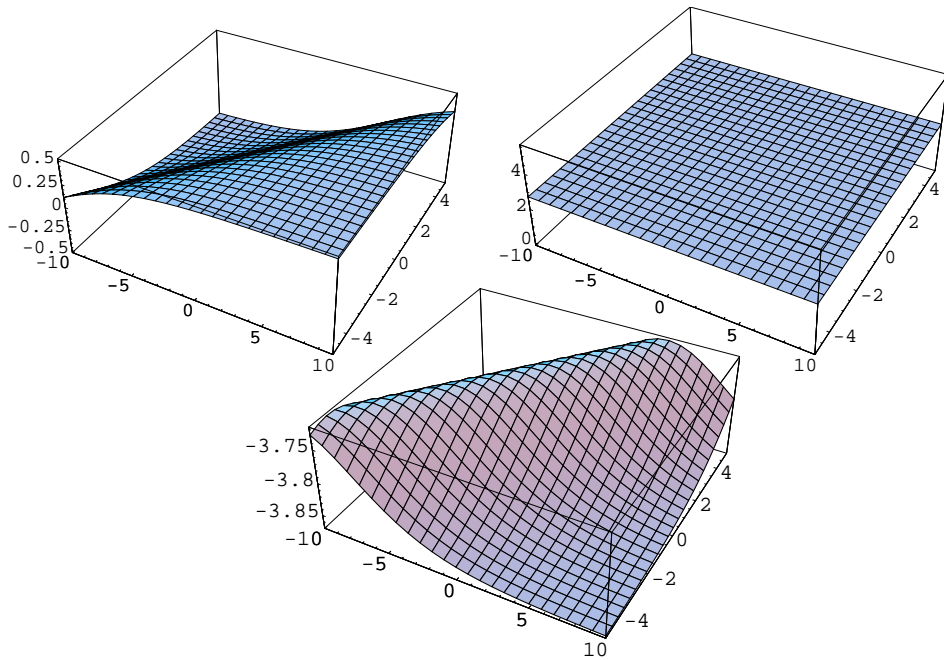

**Figure 10.** Clockwise from top left: Graphs of  $u(x, t)$ ,  $v(x, t)$  and  $\eta(x, t)$  for  $\beta = -0.5$ ,  $c_1 = -0.3$  and  $c_2 = -i$ .

## References

- [Abbasbandy et al. 2009] S. Abbasbandy, E. Babolian, and M. Ashtiani, “Numerical solution of the generalized Zakharov equation by homotopy analysis method”, *Commun. Nonlinear Sci. Numer. Simul.* **14**:12 (2009), 4114–4121. MR 2537572 Zbl 1159.65348
- [Bluman and Kumei 1989] G. W. Bluman and S. Kumei, *Symmetries and differential equations*, Applied Mathematical Sciences **81**, Springer, New York, 1989. MR 91b:58284 Zbl 0698.35001
- [Choudhury 2006] S. R. Choudhury, “Painlevé analysis of nonlinear evolution equations — an algorithmic method”, *Chaos Solitons Fractals* **27**:1 (2006), 139–152. MR 2006b:37132 Zbl 1088.35553
- [Hadouaj et al. 1991] H. Hadouaj, B. A. Malomed, and G. A. Maugin, “Dynamics of a soliton in a generalized Zakharov system with dissipation”, *Phys. Rev. A* (3) **44**:6 (1991), 3925–3931. MR 92g:35190
- [Javidi and Golbabi 2008] M. Javidi and A. Golbabi, “Exact and numerical solitary wave solutions of generalized Zakharov equation by the variational iteration method”, *Chaos, Solitons and Fractals* **36** (2008), 309–313. Zbl 05235317
- [Li et al. 2008] Y.-Z. Li, K.-M. Li, and C. Lin, “Exp-function method for solving the generalized Zakharov equations”, *Appl. Math. Comput.* **205**:1 (2008), 197–201. MR 2466623 Zbl 1160.35523
- [Malomed et al. 1997] B. Malomed, D. Anderson, M. Lisak, M. Quiroga-Teixeiro, and L. Stenflo, “Dynamics of solitary waves in the Zakharov model equations”, *Phys. Rev. E* **55** (1997), 962–968.
- [Myrzakulov 1999] R. Myrzakulov, “Singularity structure analysis, integrability solitons and dromions in  $(2 + 1)$ -dimensional Zakharov equations”, preprint, 1999. arXiv solv-int/9903008

- [Wang and Li 2005] M. Wang and X. Li, “Extended  $F$ -expansion method and periodic wave solutions for the generalized Zakharov equations”, *Phys. Lett. A* **343** (2005), 48–54. MR 2005m:35266 Zbl 1181.35255
- [Wang et al. 2007] Y.-Y. Wang, C.-Q. Dai, L. Wu, and J.-F. Zhang, “Exact and numerical solitary wave solutions of generalized Zakharov equation by the Adomian decomposition method”, *Chaos Solitons Fractals* **32**:3 (2007), 1208–1214. MR 2007h:35322 Zbl 1130.35120
- [Weiss et al. 1983] J. Weiss, M. Tabor, and G. Carnevale, “The Painlevé property for partial differential equations”, *J. Math. Phys.* **24**:3 (1983), 522–526. MR 84c:35101 Zbl 0514.35083
- [Zhang 2007] H. Zhang, “New exact travelling wave solutions of the generalized Zakharov equations”, *Rep. Math. Phys.* **60**:1 (2007), 97–106. MR 2008i:35233 Zbl 1170.35524

Received June 23, 2009. Revised January 10, 2010.

HASSAN A. ZEDAN  
MATHEMATICS DEPARTMENT  
KAFR EL-SHEIKH UNIVERSITY  
KAFR EL-SHEIKH  
EGYPT

*Current address:*

MATHEMATICS DEPARTMENT  
KING ABDUL AZIZ UNIVERSITY  
PO BOX 80203  
JEDDAH 21589  
SAUDI ARABIA  
hassanzedan2003@yahoo.com

SALMA M. AL-TUWAIQI  
MATHEMATICS DEPARTMENT  
KING ABDULAZIZ UNIVERSITY  
JEDDAH 21589  
SAUDI ARABIA  
saltuwairqi@gmail.com

# PACIFIC JOURNAL OF MATHEMATICS

<http://www.pjmath.org>

Founded in 1951 by  
E. F. Beckenbach (1906–1982) and F. Wolf (1904–1989)

## EDITORS

V. S. Varadarajan (Managing Editor)  
Department of Mathematics  
University of California  
Los Angeles, CA 90095-1555  
[pacific@math.ucla.edu](mailto:pacific@math.ucla.edu)

Vyjayanthi Chari  
Department of Mathematics  
University of California  
Riverside, CA 92521-0135  
[chari@math.ucr.edu](mailto:chari@math.ucr.edu)

Darren Long  
Department of Mathematics  
University of California  
Santa Barbara, CA 93106-3080  
[long@math.ucsb.edu](mailto:long@math.ucsb.edu)

Sorin Popa  
Department of Mathematics  
University of California  
Los Angeles, CA 90095-1555  
[popa@math.ucla.edu](mailto:popa@math.ucla.edu)

Robert Finn  
Department of Mathematics  
Stanford University  
Stanford, CA 94305-2125  
[finn@math.stanford.edu](mailto:finn@math.stanford.edu)

Jiang-Hua Lu  
Department of Mathematics  
The University of Hong Kong  
Pokfulam Rd., Hong Kong  
[jhlu@maths.hku.hk](mailto:jhlu@maths.hku.hk)

Jie Qing  
Department of Mathematics  
University of California  
Santa Cruz, CA 95064  
[qing@cats.ucsc.edu](mailto:qing@cats.ucsc.edu)

Kefeng Liu  
Department of Mathematics  
University of California  
Los Angeles, CA 90095-1555  
[liu@math.ucla.edu](mailto:liu@math.ucla.edu)

Alexander Merkurjev  
Department of Mathematics  
University of California  
Los Angeles, CA 90095-1555  
[merkurev@math.ucla.edu](mailto:merkurev@math.ucla.edu)

Jonathan Rogawski  
Department of Mathematics  
University of California  
Los Angeles, CA 90095-1555  
[jonr@math.ucla.edu](mailto:jonr@math.ucla.edu)

## PRODUCTION

[pacific@math.berkeley.edu](mailto:pacific@math.berkeley.edu)

Silvio Levy, Scientific Editor

Matthew Cargo, Senior Production Editor

## SUPPORTING INSTITUTIONS

ACADEMIA SINICA, TAIPEI  
CALIFORNIA INST. OF TECHNOLOGY  
INST. DE MATEMÁTICA PURA E APLICADA  
KEIO UNIVERSITY  
MATH. SCIENCES RESEARCH INSTITUTE  
NEW MEXICO STATE UNIV.  
OREGON STATE UNIV.

STANFORD UNIVERSITY  
UNIV. OF BRITISH COLUMBIA  
UNIV. OF CALIFORNIA, BERKELEY  
UNIV. OF CALIFORNIA, DAVIS  
UNIV. OF CALIFORNIA, LOS ANGELES  
UNIV. OF CALIFORNIA, RIVERSIDE  
UNIV. OF CALIFORNIA, SAN DIEGO  
UNIV. OF CALIF., SANTA BARBARA

UNIV. OF CALIF., SANTA CRUZ  
UNIV. OF MONTANA  
UNIV. OF OREGON  
UNIV. OF SOUTHERN CALIFORNIA  
UNIV. OF UTAH  
UNIV. OF WASHINGTON  
WASHINGTON STATE UNIVERSITY

These supporting institutions contribute to the cost of publication of this Journal, but they are not owners or publishers and have no responsibility for its contents or policies.

---

See inside back cover or [www.pjmath.org](http://www.pjmath.org) for submission instructions.

---

The subscription price for 2010 is US \$420/year for the electronic version, and \$485/year for print and electronic. Subscriptions, requests for back issues from the last three years and changes of subscribers address should be sent to Pacific Journal of Mathematics, P.O. Box 4163, Berkeley, CA 94704-0163, U.S.A. Prior back issues are obtainable from Periodicals Service Company, 11 Main Street, Germantown, NY 12526-5635. The Pacific Journal of Mathematics is indexed by Mathematical Reviews, Zentralblatt MATH, PASCAL CNRS Index, Referativnyi Zhurnal, Current Mathematical Publications and the Science Citation Index.

---

The Pacific Journal of Mathematics (ISSN 0030-8730) at the University of California, c/o Department of Mathematics, 969 Evans Hall, Berkeley, CA 94720-3840, is published monthly except July and August. Periodical rate postage paid at Berkeley, CA 94704, and additional mailing offices. POSTMASTER: send address changes to Pacific Journal of Mathematics, P.O. Box 4163, Berkeley, CA 94704-0163.

---

PJM peer review and production are managed by EditFLOW™ from Mathematical Sciences Publishers.

PUBLISHED BY PACIFIC JOURNAL OF MATHEMATICS  
at the University of California, Berkeley 94720-3840  
A NON-PROFIT CORPORATION

Typeset in L<sup>A</sup>T<sub>E</sub>X

Copyright ©2010 by Pacific Journal of Mathematics

# PACIFIC JOURNAL OF MATHEMATICS

Volume 247    No. 2    October 2010

---

A family of representations of braid groups on surfaces BYUNG HEE AN and KI HYOUNG KO	257
Parametrization of holomorphic Segre-preserving maps R. BLAIR ANGLE	283
Chern classes on differential $K$ -theory ULRICH BUNKE	313
Laplacian spectrum for the nilpotent Kac–Moody Lie algebras DMITRY FUCHS and CONSTANCE WILMARTH	323
Sigma theory and twisted conjugacy classes DACIBERG GONÇALVES and DESSISLAVA HRISTOVA KOCHLOUKOVA	335
Properties of annular capillary surfaces with equal contact angles JAMES GORDON and DAVID SIEGEL	353
Approximating annular capillary surfaces with equal contact angles JAMES GORDON and DAVID SIEGEL	371
Harmonic quasiconformal self-mappings and Möbius transformations of the unit ball DAVID KALAJ and MIODRAG S. MATELJEVIĆ	389
Klein bottle and toroidal Dehn fillings at distance 5 SANGYOP LEE	407
Representations of the two-fold central extension of $SL_2(\mathbb{Q}_2)$ HUNG YEAN LOKE and GORDAN SAVIN	435
Large quantum corrections in mirror symmetry for a 2-dimensional Lagrangian submanifold with an elliptic umbilic GIOVANNI MARELLI	455
Crossed pointed categories and their equivariantizations DEEPAK NAIDU	477
Painlevé analysis of generalized Zakharov equations HASSAN A. ZEDAN and SALMA M. AL-TUWAIRQI	497

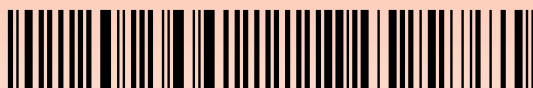

0030-8730(201010)247:2;1-D